

T-8452B

パーツブック
PARTS BOOK

2本針本縫ダイレクトドライブ角縫自動糸切りミシン
TWIN NEEDLE DIRECT DRIVE SPLIT NEEDLE BAR LOCK STITCHER
WITH THREAD TRIMMER

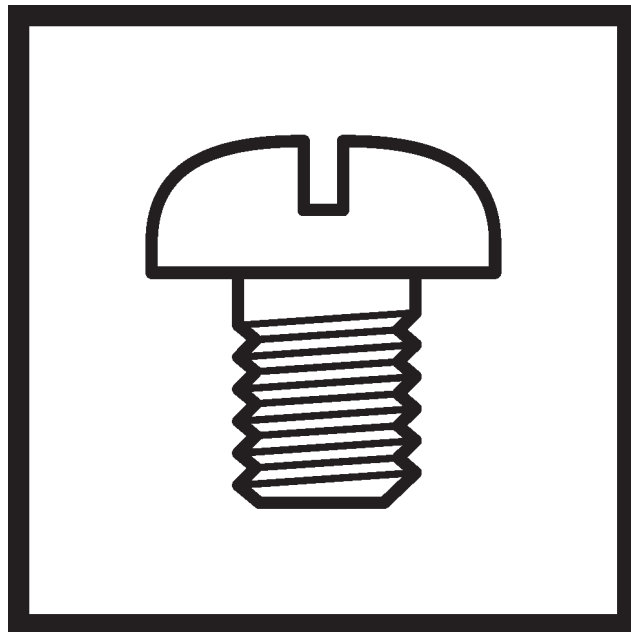

brother[®]

最新の部品情報は Parts Navigation でご覧いただけます。 <http://partsbook.brother.co.jp/partsnavi/jpn/>
The latest parts information, refer to the Parts Navigation. <http://partsbook.brother.co.jp/partsnavi/eng/>

型式板の見方

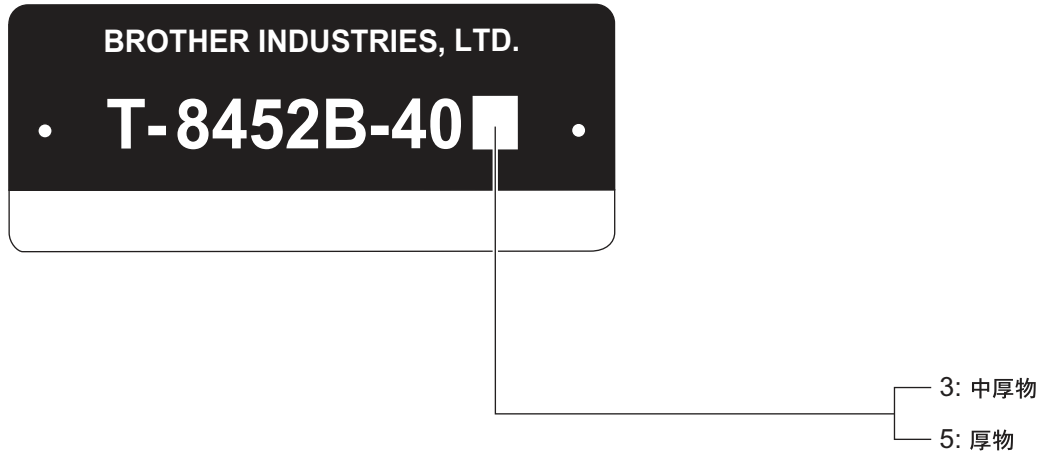

Description of model plate



3: Medium-weight materials

5: Heavy-weight materials

パーツブックご利用に際して

1. この本は、2006年11月のデータに基づいて作成されたものです。
2. 部品は予告なしに設計変更される場合があります。
3. 組単位で補給する部品は、破線で示してあります。

目 次

A. 主体関係	1
B. 上軸関係	3
C. 針棒揺動関係	5
D. 針棒切替操作関係	9
E. 押え関係	11
F. 送り関係	13
G. 逆転関係	15
H. 送り軸関係	17
J. ゲージ関係	19
K1. かま関係	21
K2. かま関係	25
L. 下軸関係	27
M. 給油潤滑関係	29
N. 糸通し関係	33
P. 糸巻関係	35
Q. 糸切り関係	37
R. 糸緩め関係	39
S. 糸払い関係	41
T1. コントロールボックス、モータ関係	43
T2. コントロールボックス関係	45
U. 逆転スイッチ関係	47
V. 電装品関係	49
W. 電磁押え上げセット関係(オプション部品)	51
Z1. 付属品関係	53
Z2. 付属品関係	55
Wa. 警告ラベル	57
Sp. 仕様別部品一覧表	58
Ga1. ゲージ一覧表	59
索引	63

Notes for using this parts book

1. This book was prepared based on information available in November 2006.
2. Parts are subject to changes in design without prior notice.
3. Parts supplied as complete assemblies are circled by a dotted line.

CONTENTS

A. Machine body	1
B. Upper shaft mechanism	3
C. Needle bar rocking mechanism	5
D. Needle bar flip-up mechanism	9
E. Presser foot mechanism	11
F. Feed mechanism	13
G. Quick reverse mechanism	15
H. Feed shaft mechanism	17
J. Gauge parts	19
K1. Rotary hook mechanism	21
K2. Rotary hook mechanism	25
L. Lower shaft mechanism	27
M. Lubrication	29
N. Threading mechanism	33
P. Bobbin winder mechanism	35
Q. Thread trimmer mechanism	37
R. Tension release mechanism	39
S. Thread wiper mechanism	41
T1. Control box and motor mechanism	43
T2. Control box mechanism	45
U. Quick reverse switch mechanism	47
V. Power supply equipment mechanism	49
W. Presser foot lifting solenoid set mechanism (Option parts)	51
Z1. Accessories	53
Z2. Accessories	55
Wa. Warning labels	57
Sp. Different parts list	58
Ga1. Gauge parts list	59
Index	63

A. 主体関係 / Machine body

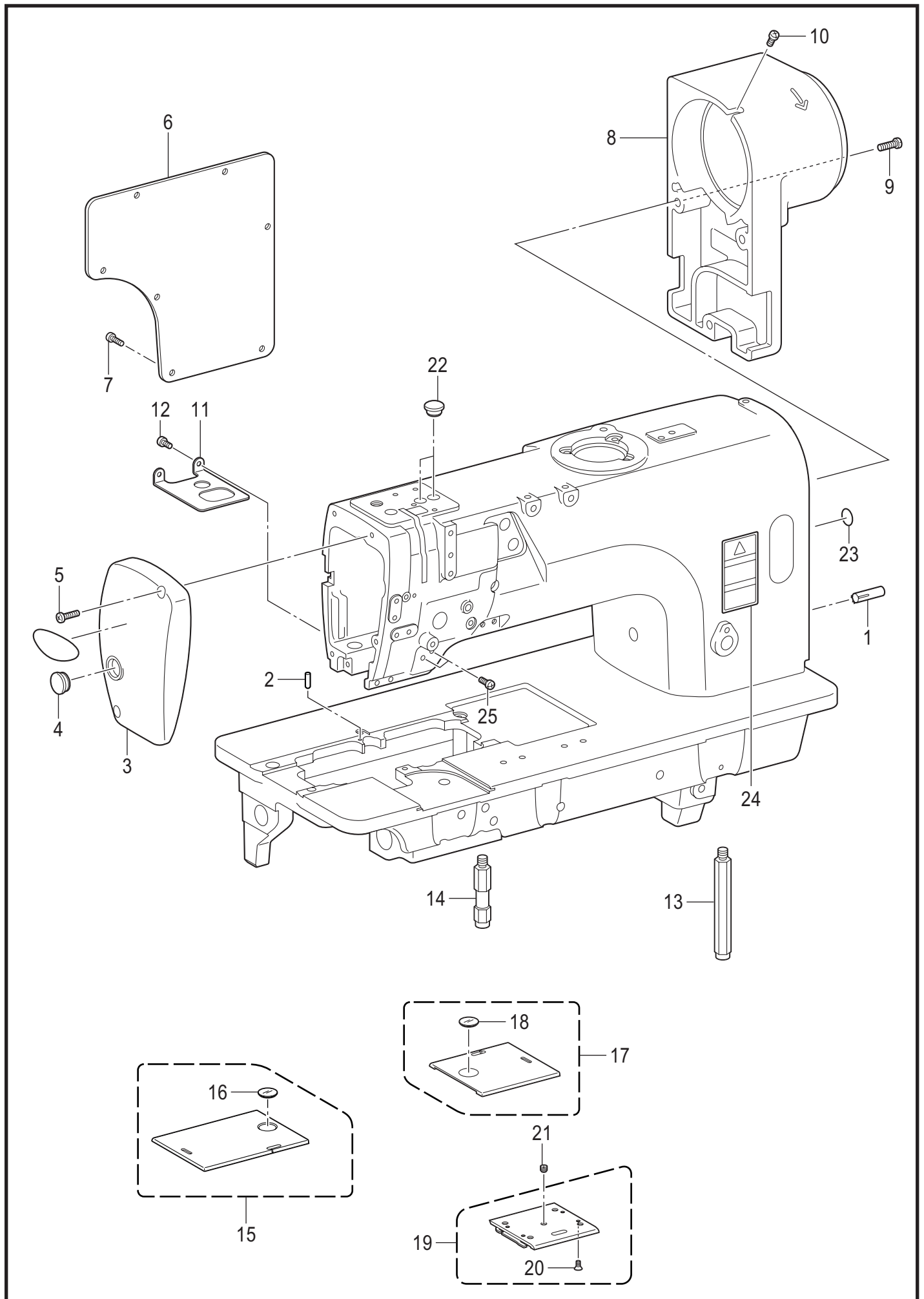

A . 主体関係 / Machine body

REF.NO	CODE	Q'TY	品名	NAME OF PARTS	RM
1	140063001	2	ミゾツキピン	DOWEL PIN	
2	SA3924001	1	ハライタイチキメピン	POSITIONING PIN	
3	SA4364101	1	メンイタ	FACE PLATE	
4	104449001	1	ゴムセン15.5	RUBBER CAP, 15.5	
5	062501416	2	ナベコ5X14	SCREW PAN M5X14	
6	SA2441001	1	ガワイタ	REAR COVER	
7	062501216	7	ナベコ5X12	SCREW PAN M5X12	
8	SA2442101	1	モータカバー	MOTOR COVER	
9	062501416	3	ナベコ5X14	SCREW PAN M5X14	
10	062501016	1	ナベコ5X10	SCREW PAN M5X10	
11	SA4370101	1	ダストプレート	DUST PROTECTOR	
12	062500616	2	ナベコ5X6	SCREW PAN M5X6	
13	SA2444101	1	キヤクチュウL	BED LEG L	
14	SA2445101	1	キヤクチュウS	BED LEG S	
15	SA2447001	1	スベリイタLAクミ	SLIDE PLATE, LA ASSY	
16	SA2479001	1	スベリイタマド	BOBBIN WINDOW	
17	SA2449001	1	スベリイタRクミ	SLIDE PLATE ASSY, R	
18	SA2479001	1	スベリイタマド	BOBBIN WINDOW	
19	S36663051	1	スベリイタFクミ	SLIDE PLATE F ASSY	
20	S34438051	4	サラネジ3.18X4	SCREW, FLAT SM3.18-40X4	
21	116010001	1	トメネジ5.16	SET SCREW, SM5.16-40X4	
22	SA2929001	2	ゴムセン12.5	RUBBER CAP, 12.5	
23	S37060001	1	ア-スマーク	LABEL, GROUNDING	
			< 中国向以外 >	< Except for China >	
24	SA2040001	1	ラベルチュウイ.ワイ	LABEL, CAUTION JPN/ENG	
			< 中国向 >	< For China only >	
24	SA2041001	1	ラベルチュウイ.チュウエイ	LABEL, CAUTION CHN/ENG	
25	062500816	2	ナベコ5X8	SCREW PAN M5X8	

B. 上軸関係 / Upper shaft mechanism

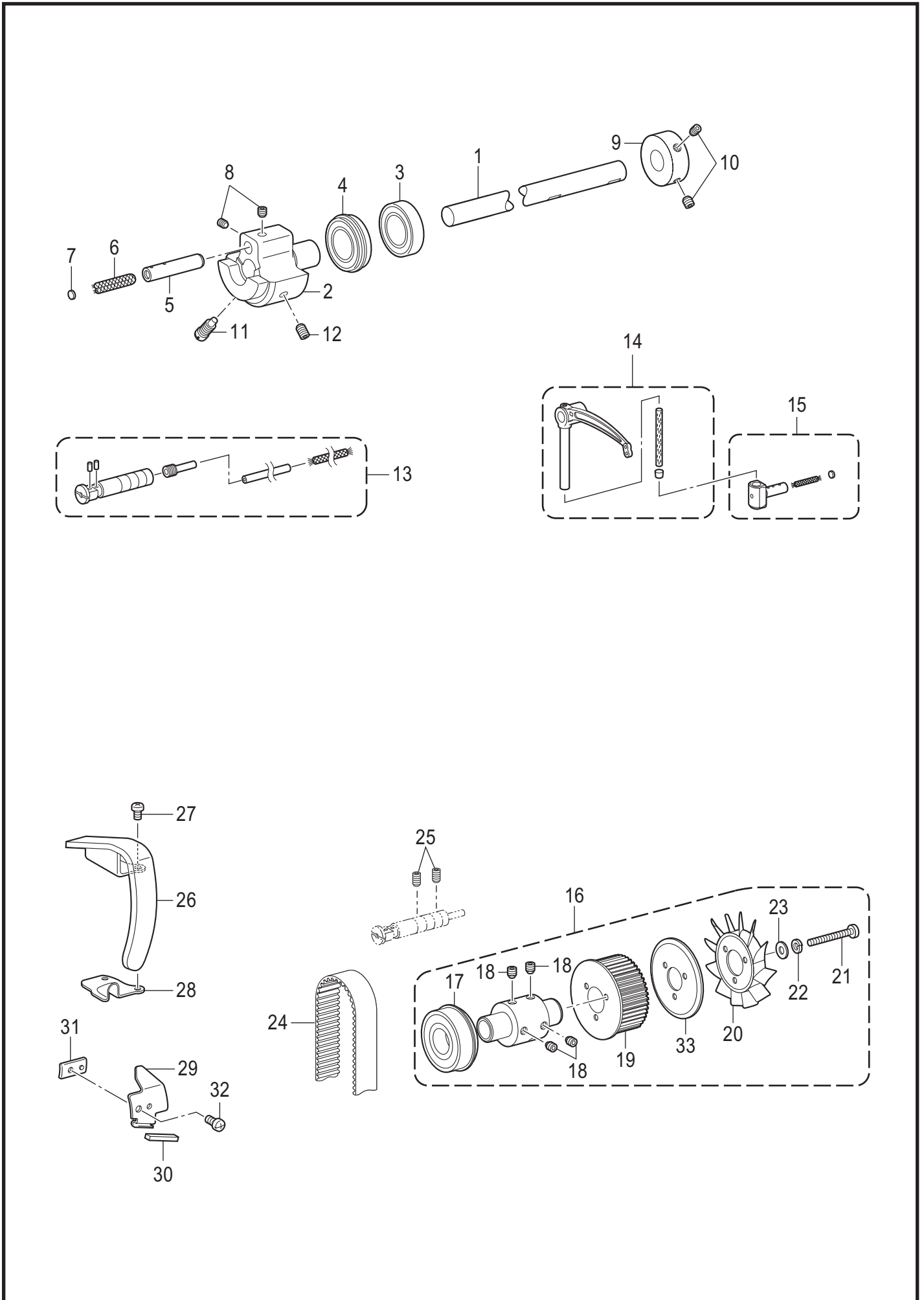

B . 上軸関係 / Upper shaft mechanism

REF.NO	CODE	Q'TY	品名	NAME OF PARTS	RM
1	SA4551001	1	ウワジクDD	UPPER SHAFT, DD	
2	SA4373001	1	テンビンクランク	THREAD TAKE-UP CRANK	
3	S25234001	1	タマジクウケ6004ZZ	BALL BEARING, 6004ZZ	
4	S38707001	1	タマジクウケ6004ZZNR	BALL BEARING, 6004ZZNR	
5	SA6166001	1	ハリボウクランクジク	CRANKSHAFT	
6	117006001	1	クミヒモ	WICK, L=60	
7	113014000	1	クミヒモフタ	PUSHER	
8	S25260001	2	アナヒラ6X5ホソメ	SET SCREW SOCKET (FT) M6X5	
9	SA1120001	1	イトマキドウリン	BOBBIN WINDER DRIVING WHEEL	
10	S23651001	2	アナヒラ6X6ホソメ	SET SCREW SOCKET (FT) M6X6	
11	S25235001	1	シメネジ8	SCREW M8	
12	S25236001	1	アナヒラ6X10ホソメ	SET SCREW SOCKET (FT) M6X10	
13	SA2861101	1	テンビンササエジクソウクミ	THREAD TAKE-UP S-SHAFT UNIT	
14	SA2935101	1	テンビンS3-Lクミ	THREAD TAKE-UP LEVER ASSY, S3-L	
15	S13160001	1	テンビンスベリコ2クミ	T-TAKE-UP SLIDE BLOCK ASSY, 2	
16	SA2460001	1	ツギテソウクミ	PRESSER ADJUSTING UNIT	
17	S38710001	1	タマジクウケ6204ZZNR	BALL BEARING, 6204ZZNR	
18	S23651001	4	アナヒラ6X6ホソメ	SET SCREW SOCKET (FT) M6X6	
19	SA2461001	1	タイミングプーリU DD	TIMING PULLEY, U DD	
20	S38713100	1	ファン	FAN	
21	062403512	3	ナベコ4X35	SCREW PAN M4X35	
22	028040242	3	バネザガネ2-4	WASHER SPRING 2-4	
23	025040232	3	ヒラザガネチユウ4	WASHER PLAIN M 4	
24	SA2463001	1	タイミングベルト	TIMING BELT	
25	012061036	2	アナヒラ6X10	SET SCREW SOCKET (FT) M6X10	
26	SA2469001	1	テンビンカバー	THREAD TAKE-UP LEVER COVER	
27	062500816	2	ナベコ5X8	SCREW PAN M5X8	
28	SA4537001	1	ダストカバー	DUST COVER	
29	SA4376101	1	シャヘイバン	SHELTER PLATE	
30	SA3065001	1	フェルト	FELT	
31	SA3059101	1	シャヘイバンオサエ	HOLDER, SHELTER PLATE	
32	062500816	1	ナベコ5X8	SCREW PAN M5X8	
33	SA2462001	1	プーリUフランジ	PULLEY U FLANGE	

C. 針棒搖動關係 / Needle bar rocking mechanism

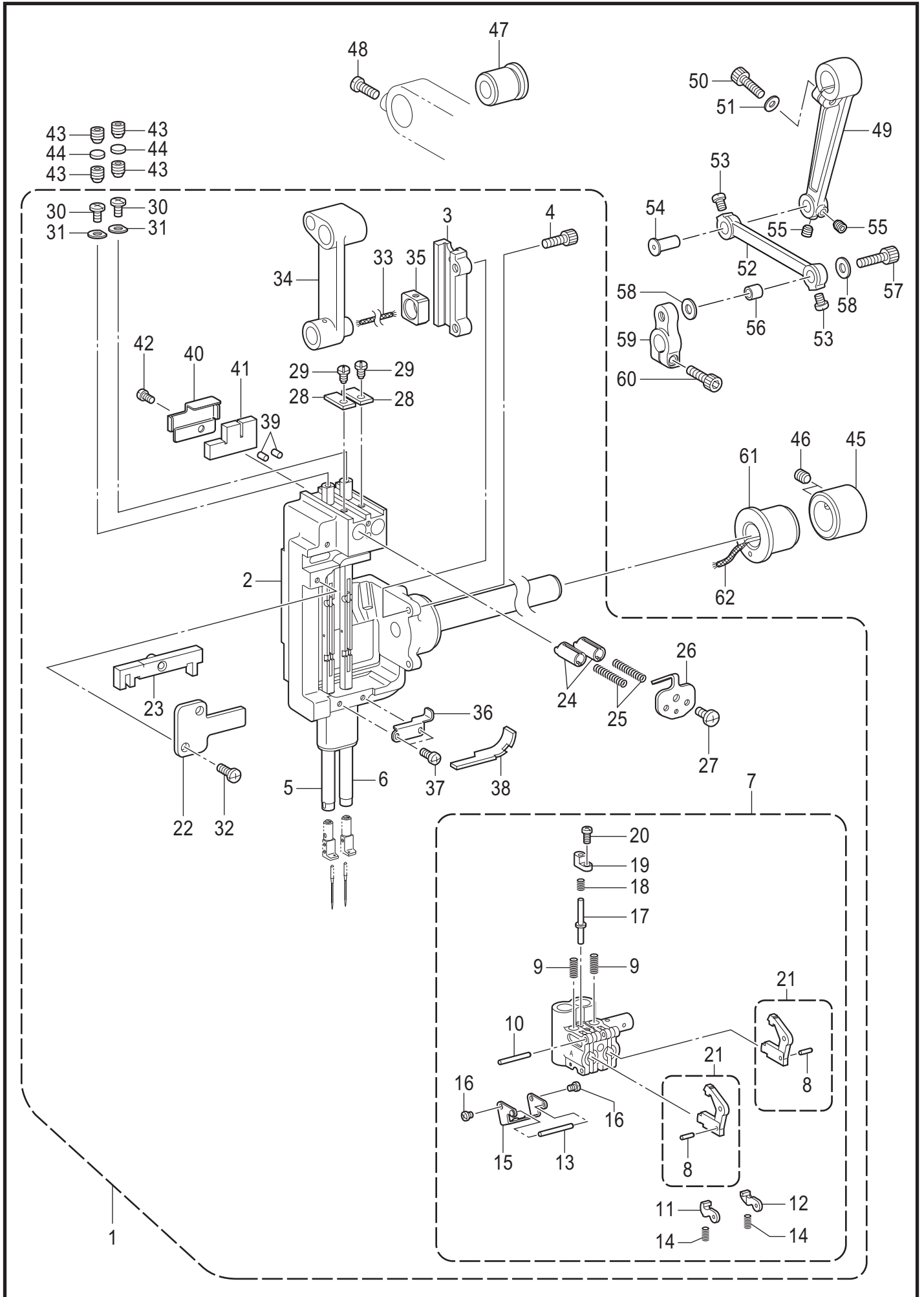

C. 針棒揺動関係 / Needle bar rocking mechanism

REF.NO	CODE	Q'TY	品名	NAME OF PARTS	RM
1	SA8738001	1	ハリボウヨウドウジクソウクミ	NEEDLE BAR ROCKER SHAFT UNIT	
2	SA8740001	1	ハリボウダイクミ	NEEDLE BAR BASE ASSY	
3	SA2474201	1	カクコマスライダ	SLIDE BLOCK SLIDER	
4	018401036	2	アナボルト4X10	BOLT SOCKET M4X10	
5	SA4382001	1	ハリボウLクミ	NEEDLE BAR ASSY L	
6	SA4385001	1	ハリボウRクミ	NEEDLE BAR ASSY R	
			必ず記号を確認後注文のこと	Need check the "Mark" the following parts before ordering.	
7	SA4387001	1	ハリボウダキクミ <記号A>	NEEDLE BAR CLAMP ASSY <Mark A>	
7	SA4387002	1	ハリボウダキクミ <記号B>	NEEDLE BAR CLAMP ASSY <Mark B>	
7	SA4387003	1	ハリボウダキクミ <記号C>	NEEDLE BAR CLAMP ASSY <Mark C>	
7	SA8749001	1	ハリボウダキクミ <記号Z>	NEEDLE BAR CLAMP ASSY <Mark Z>	
8	149604001	2	ピン1.5X5.8	PIN, 1.5X5.8	
9	149605001	2	クラツチテコバネ	SPRING, CLUTCH LEVER	
10	149827001	1	ピン2X15.8	PIN, 2X15.8	
11	S34561101	1	クラツチトメL	CLUTCH STOPPER L	
12	S34562101	1	クラツチトメR	CLUTCH STOPPER R	
13	149608001	1	ピン2X17.8	PIN, 2X17.8	
14	112609001	2	スベリイタストツパバネ	SPRING	
15	SA4391001	1	バネササエ	SPRING HOLDER	
16	062260316	2	ナベコ26X3	SCREW PAN M2.6X3	
17	149610001	1	リリースピン	PIN	
18	149611101	1	リリースピンバネ	SPRING, RELEASE PIN	
19	SA4392001	1	リリースピンフタ	PIN COVER	
20	062260516	1	ナベコ26X5	SCREW PAN M2.6X5	
21	SA4389101	2	クラツチテコクミ	CLUTCH LEVER ASSY	
22	SA4395001	1	スベリコアンナイイタ	SLIDE BLOCK GUIDE PLATE	
			必ず記号を確認後注文のこと	Need check the "Mark" the following parts before ordering.	
23	S07575000	1	スベリコクミ <記号25>	SLIDE BLOCK ASSY, 25 <Mark 25>	
23	S07575001	1	スベリコクミ <記号30>	SLIDE BLOCK ASSY, 30 <Mark 30>	
23	S07575002	1	スベリコクミ <記号35>	SLIDE BLOCK ASSY, 35 <Mark 35>	
23	S07575003	1	スベリコクミ <記号40>	SLIDE BLOCK ASSY, 40 <Mark 40>	
23	S07575004	1	スベリコクミ <記号45>	SLIDE BLOCK ASSY, 45 <Mark 45>	
23	S07575005	1	スベリコクミ <記号50>	SLIDE BLOCK ASSY, 50 <Mark 50>	
23	S07575006	1	スベリコクミ <記号55>	SLIDE BLOCK ASSY, 55 <Mark 55>	
23	S07575007	1	スベリコクミ <記号60>	SLIDE BLOCK ASSY, 60 <Mark 60>	
23	S07575008	1	スベリコクミ <記号65>	SLIDE BLOCK ASSY, 65 <Mark 65>	
23	S07575009	1	スベリコクミ <記号70>	SLIDE BLOCK ASSY, 70 <Mark 70>	
23	S07575010	1	スベリコクミ <記号75>	SLIDE BLOCK ASSY, 75 <Mark 75>	
23	S07575011	1	スベリコクミ <記号80>	SLIDE BLOCK ASSY, 80 <Mark 80>	
24	SA4583001	2	ハリボウストツパー	STOPPER, N-BAR	
25	149622001	2	ハリボウストツパーバネ	SPRING, N-BAR STOPPER	
26	SA4396001	1	バネフタ	SPRING COVER	
27	060350616	1	バインド35X6	SCREW BIND M3.5X6	
28	SA4397001	2	ハリボウマワリトメ	ROTATE STOPPER, N-BAR	
29	SA4398001	2	シメネジ3.5	SCREW, SM3.5	
30	060350616	2	バインド35X6	SCREW BIND M3.5X6	
31	SA4399001	2	ザガネ	WASHER, PLANE	
32	062350816	2	ナベコ35X8	SCREW PAN M3.5X8	
33	112728001	1	クミヒモ	WICK, L=50	
34	SA4393101	1	ハリボウクランクロツド	CRANK ROD, N-BAR	
35	SA4394001	1	カクコマ	SLIDE BLOCK	
36	SA4401001	1	フェルトオサエD	FELT SUPPORT, D	
37	062350516	2	ナベコ35X5	SCREW PAN M3.5X5	
38	SA4400001	1	フェルト	FELT	
39	107155001	2	フェルト	FELT	
40	SA5155001	1	フェルトササエ	FELT SUPPORT	

C . 針棒搖動關係 / Needle bar rocking mechanism

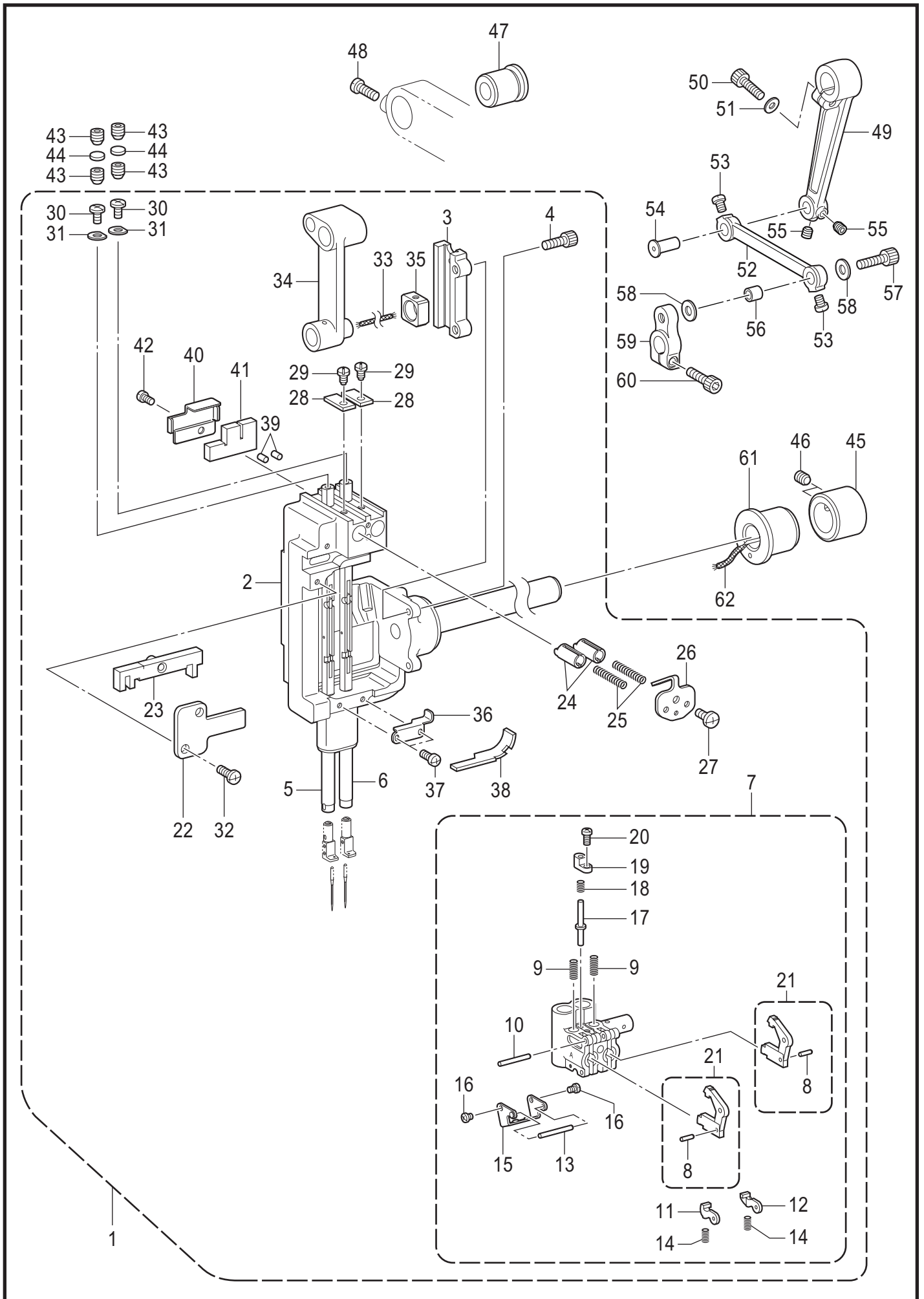

C. 針棒揺動関係 / Needle bar rocking mechanism

REF.NO	CODE	Q'TY	品名	NAME OF PARTS	RM
41	SA5237101	1	フェルト	FELT	
42	062350516	1	ナベコ35X5	SCREW PAN M3.5X5	
43	014080831	4	アナクボミ8X8	SET SCREW SOCKET (CP) M8X8	
44	154567000	2	カンザ5.3	SPACER, 5.3	
45	SA2485001	1	セットカラ-	SET SCREW COLLAR	
46	S25260001	2	アナヒラ6X5ホソメ	SET SCREW SOCKET (FT) M6X5	
47	SA2486101	1	ヨウドウジクメタルR	BUSH, R	
48	062061616	1	ナベコ6X16	SCREW PAN M6X16	
49	SA2489001	1	ハリボウヨウドウレバー	NEEDLE BAR ROCKER LEVER	
50	018062032	1	アナボルト6X20	BOLT SOCKET M6X20	
51	118735002	1	ザガネ	WASHER	
52	SA2490101	1	ハリボウヨウドウリンク	ROCKER LINK N-BAR	
53	S23460001	2	ナベコ6X5	SCREW PAN M6X5	
54	SA4117001	1	ヨウドウリンクジクP	LINK SHAFT, N-BAR ROCKER P	
55	012060636	2	アナヒラ6X6	SET SCREW SOCKET (FT) M6X6	
56	SA4118001	1	ヨウドウリンクカラ-P	ZIGZAG LINK BUSH, P	
57	018062532	1	アナボルト6X25	BOLT SOCKET M6X25	
58	SA2493001	2	ザガネ	WASHER, PLAIN	
59	SA2494001	1	ハリボウヨウドウウデ	NEEDLE BAR ROCK ARM	
60	018062032	1	アナボルト6X20	BOLT SOCKET M6X20	
61	SA5332001	1	ヨウドウジクメタルL	BUSH L	
62	S48204000	1	クミヒモ4X4	WICK, 4X4 L=150	

D. 針棒切換操作關係 / Needle bar flip-up mechanism

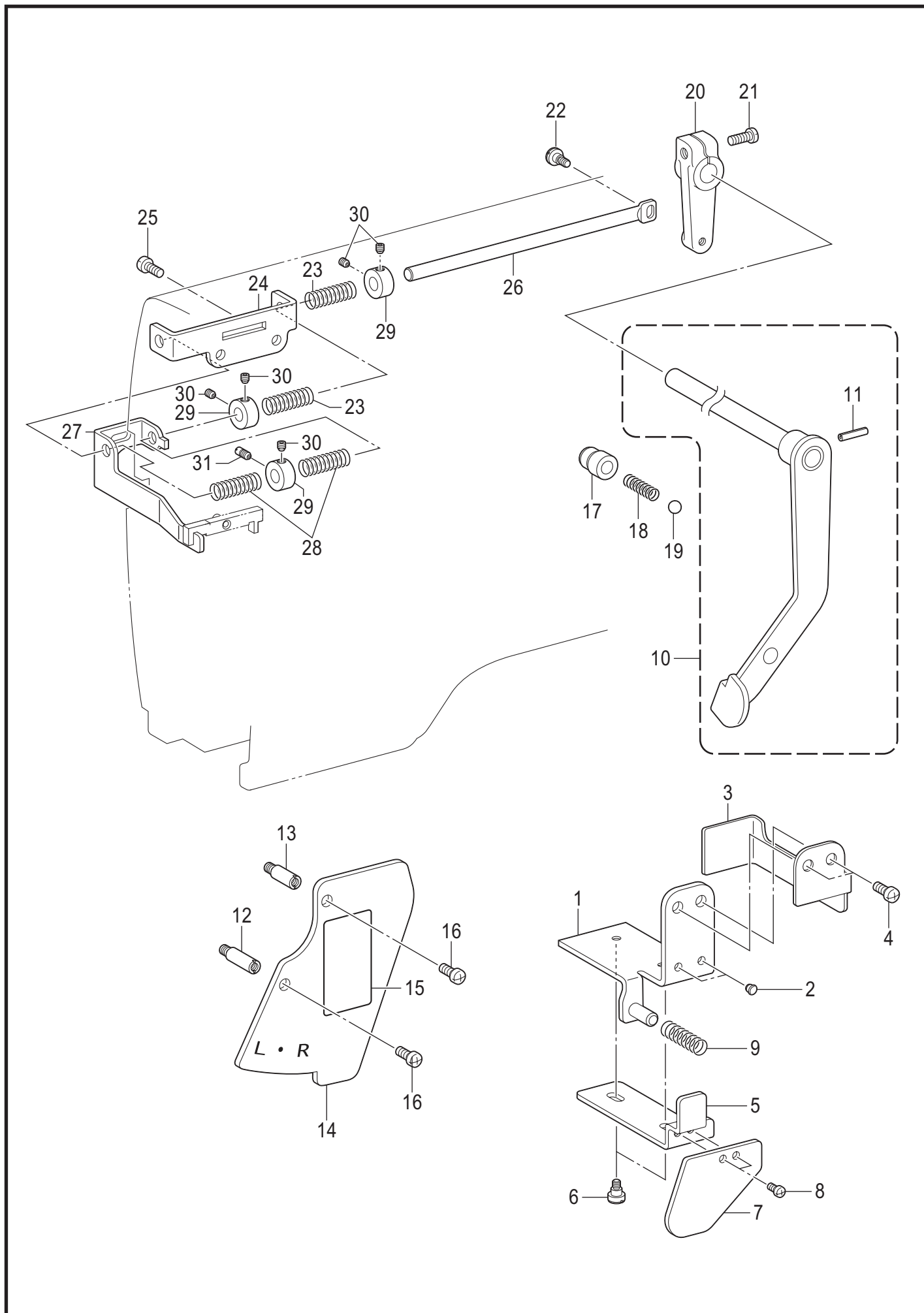

D. 針棒切替操作関係 / Needle bar flip-up mechanism

REF.NO	CODE	Q'TY	品名	NAME OF PARTS	RM
1	SA4402001	1	シジイタクミ	INDICATION PLATE ASSY	
2	104833001	2	ゴムセン4.3	RUBBER CAP, 4.3	
3	SA5336001	1	シジイタカバー	HOLDER PLATE COVER	
4	062501016	2	ナベコ5X10	SCREW PAN M5X10	
5	SA4404001	1	プツシユレバー	PUSH LEVER	
6	SA4441001	2	ダンネジM4	SHOULDER SCREW, M4	
7	SA4405001	1	プツシユレバーイタ	PLATE, PUSH LEVER	
8	062350516	2	ナベコ35X5	SCREW PAN M3.5X5	
9	SA5333001	1	プツシユレバーバネ	SPRING	
10	SA4406001	1	ストップレバージクミ	STOP LEVER SHAFT ASSY	
11	047301842	1	スプリングピンAW3	PIN SPRING ROLL AW3	
12	SA4408001	1	スタッドL	STUD, L	
13	SA4409001	1	スタッドS	STUD, S	
14	SA4411101	1	キリカエシジイタ	FLIP-UP HOLDER PLATE	
15	S18964001	1	<中国向以外> キリカエシジイタラベル.ワエイ	<Except for China> LABEL	
15	SA4419001	1	<中国向> キリカエシジイタラベル.チュウエイ	<For China only> LABEL	
16	062500816	2	ナベコ5X8	SCREW PAN M5X8	
17	SA4412001	1	タマアンナイブツシユ	BALL GUIDE BUSH	
18	150820001	1	タマオシバネ	SPRING	
19	071063550	1	コウキユウ1/4	BEARING BALL, 1/4	
20	SA4413001	1	レバージクウデ	ARM LEVER SHAFT	
21	062501416	1	ナベコ5X14	SCREW PAN M5X14	
22	SA5588001	1	ダンネジM4	SHOULDER SCREW M4	
23	SA4414001	2	レバージクウデバネ	SPRING	
24	SA4415001	1	スライドジクウケ	SLIDE SHAFT BRACKET	
25	062500816	2	ナベコ5X8	SCREW PAN M5X8	
26	S07588101	1	スライドジク	SLIDE SHAFT	
27	SA4416001	1	スライドジクウケイタ	SUPPORT PLATE, SLIDE SHAFT	
28	149863001	2	ジクウケイタバネ	SPRING, PLATE	
29	SA4417001	3	セットカラ-	SET SCREW COLLAR	
30	014400432	5	アナクボミ4X4	SET SCREW SOCKET (CP) M4X4	
31	SA4418001	1	アンナイネジ	GUIDE SCREW	

E . 押え関係 / Presser foot mechanism

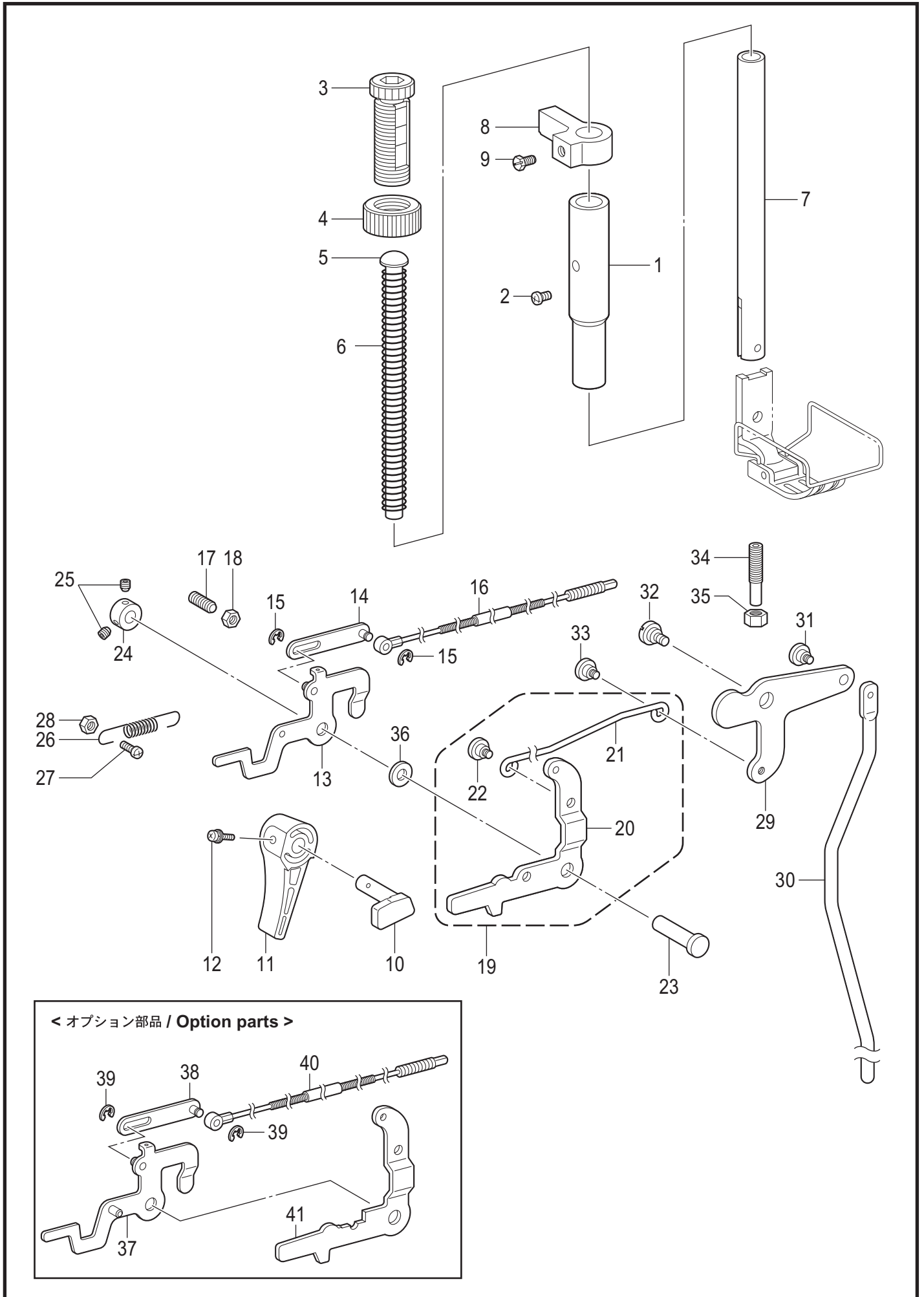

E . 押え関係 / Presser foot mechanism

REF.NO	CODE	Q'TY	品名	NAME OF PARTS	RM
1	SA2495001	1	オサエボウメタル	PRESSER BAR BUSH	
2	062500816	1	ナベコ5X8	SCREW PAN M5X8	
3	SA1174001	1	オサエチヨウセツネジM14	PRESSER ADJUSTING SCREW, M14	
4	SA1175001	1	チヨウセツネジナツトM14	ADJUST SCREW NUT	
5	SA7607001	1	オサエバネアンナイ	SPRING GUIDE	
6	S07346101	1	オサエバネ	PRESSER BAR SPRING, -5	
7	SA2496001	1	オサエボウ	PRESSER BAR	
8	SA2498001	1	オサエボウダキ	GUIDE BRACKET, P-BAR	
9	S25289001	1	ボルト6	BOLT (CP) M6X10	
10	SA2499001	1	オサエアゲクランク	PRESSER BAR LIFTING CRANK	
11	S31006001	1	オサエアゲテコ	LIFTING LEVER	
12	S39051001	1	ナベザクミ35X12	SCREW PAN (S/P W) M3.5X12	
13	S07351001	1	イトユルメイタクミ	TENSION RELEASE PLATE ASSY	
14	S07529001	1	イトユルメレンカクミ	T-RELEASE CONNECTING ROD ASSY	
15	048030342	2	トメワE3	RETAINING RING E3	
16	SA2677001	1	イトユルメワイヤー	TENSION RELEASE WIRE	
17	012061832	1	アナヒラ6X18	SET SCREW, SOCKET (FT) M6X18	
18	021060306	1	3シュナツト6	NUT 3 M6	
19	SA2500001	1	ヒザアゲレンカクミ	KNEE LIFTER C-ROD ASSY	
20	SA2501001	1	オサエアゲレバー	PRESSER BAR LIFTING LEVER	
21	SA2502001	1	ヒザアゲレンカン	KNEE LIFTER CONNECTING ROD	
22	SA1179001	1	ダンネジ5	SHOULDER SCREW, M5	
23	S07349001	1	オサエアゲレバージク	P-BAR LIFTING LEVER SHAFT	
24	SA2504001	1	セットカラー	SET SCREW COLLAR	
25	012500536	2	アナヒラ5X5	SET SCREW SOCKET (FT) M5X5	
26	S07355051	2	オサエアゲレバーバネ	SPRING, EXTENSION	
27	062501216	1	ナベコ5X12	SCREW PAN M5X12	
28	021500106	1	1シュナツト5	NUT, 1 M5	
29	SA2506001	1	ヒザアゲレバー	KNEE LIFTER LEVER	
30	SA2507001	1	ヒザアゲボウ	KNEE LIFTER BAR	
31	SA1179001	1	ダンネジ5	SHOULDER SCREW, M5	
32	SA2165001	1	ダンネジ6	SHOULDER SCREW, M6	
33	SA1179001	1	ダンネジ5	SHOULDER SCREW, M5	
34	SA4149101	1	チヨウセツネジ6	ADJUSTING SCREW 6	
35	021060306	1	3シュナツト6	NUT 3 M6	
36	S07350001	1	ザガネ	WASHER, PLAIN	
			<オプション部品>	<Option parts>	
37	S10780001	1	イトユルメイタクミ	TENSION RELEASE PLATE ASSY	
38	S07529001	1	イトユルメレンカクミ	T-RELEASE CONNECTING ROD ASSY	
39	048030342	2	トメワE3	RETAINING RING E3	
40	SA2677001	1	イトユルメワイヤー	TENSION RELEASE WIRE	
41	SA2578001	1	オサエアゲレバー	PRESSER BAR LIFTING LEVER	

F. 送り関係 / Feed mechanism

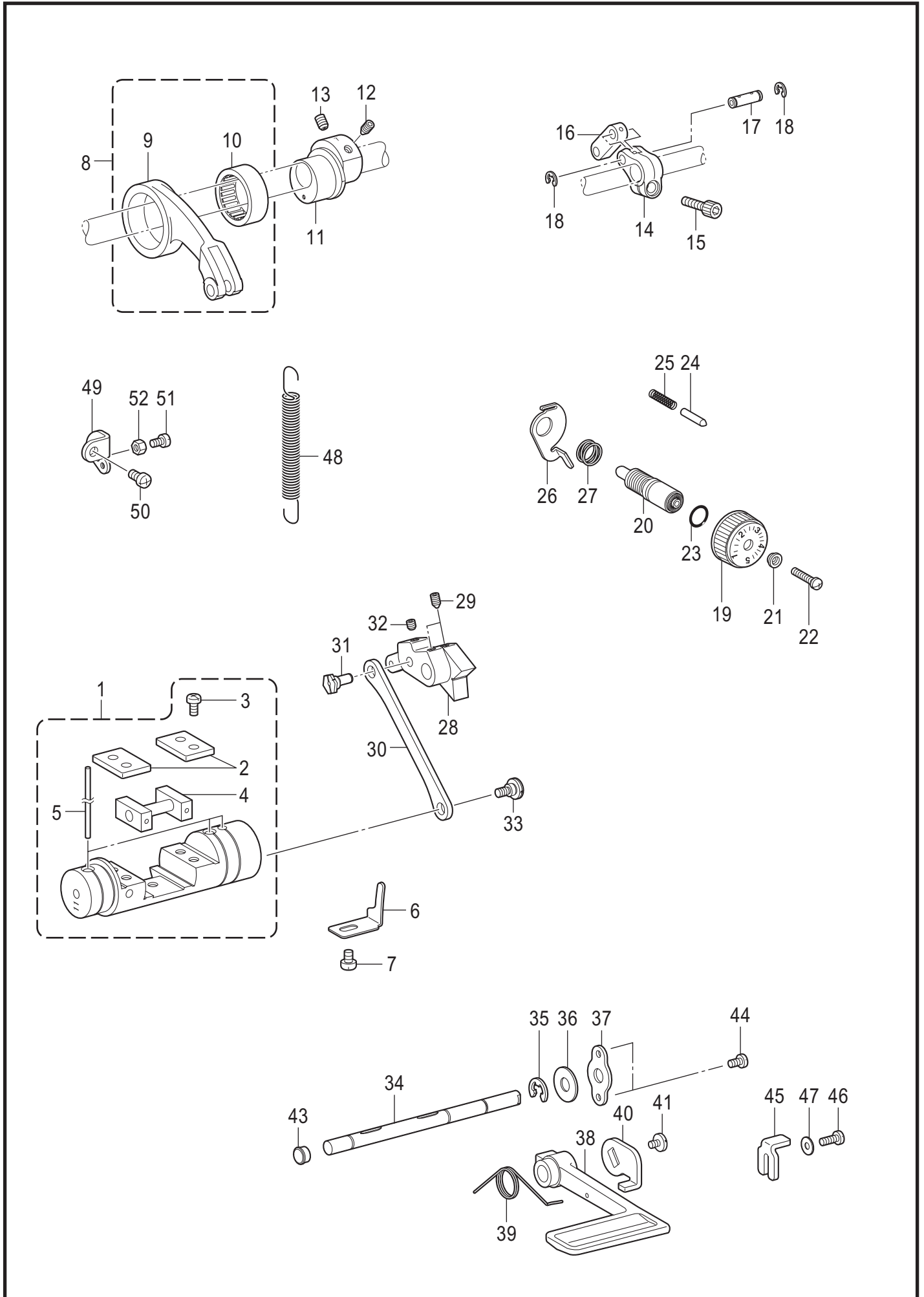

F . 送り関係 / Feed mechanism

REF.NO	CODE	Q'TY	品名	NAME OF PARTS	RM
1	SA2509001	1	キリカエキクミ	FEED REGULATOR ASSY	
2	SA2511001	2	カクコマアンナイタ	GUIDE PLATE	
3	062501016	4	ナベコ5X10	SCREW PAN M5X10	
4	SA2512001	1	キリカエキカクコマクミ	SLIDE BLOCK ASSY	
5	SA2515001	3	フェルト	FELT	
6	SA2516001	1	キリカエキトメ	STOPEER	
7	062060816	1	ナベコ6X8	SCREW PAN M6X8	
8	143611201	1	スイヘイオクリレンカンクミ	F-ROCKER CONNECTING ROD ASSY	
9	143612100	1	スイヘイオクリレンカン	FEED ROCKER CONNECTING ROD	
10	118954000	1	ニードルベアリング	NEEDLE BEARING	
11	SA2518001	1	スイヘイヘンシンリン5	LEVEL FEED ECCENTRIC WHEEL 5	
12	SA2585001	1	アナトガリ6X10ホソメ	SET SCREW, SOCKET (FT) M6	
13	S25236001	1	アナヒラ6X10ホソメ	SET SCREW SOCKET (FT) M6X10	
14	SA2521001	1	スイヘイオクリウデ5	FEED ROCKER ARM 5	
15	018062032	1	アナボルト6X20	BOLT SOCKET M6X20	
16	143613051	1	スイヘイオクリウデリンク	LINK	
17	143616001	1	スイヘイオクリウデジク	SHAFT	
18	048060342	2	トメワE6	RETAINING RING E6	
19	S38427001	1	オクリメモリダイヤル	STITCH LENGTH DIAL, 5	
20	SA3056001	1	オクリチヨウセツネジ	FEED REGULATING STUD	
21	142746122	1	メモリイタオサエ	FEED REGULATING SUPPORTER	
22	129458202	1	シメネジ4.76	SCREW SM4.76	
23	108549001	1	Oリング	O RING	
24	S50098101	1	メモリイチギメピン	POSITIONING PIN	
25	100328001	1	メモリイチキメピンバネ	NOTCH SPRING	
26	SA2523001	1	ダイヤルロックレバー	DIAL LOCK LEVER	
27	S39830101	1	ダイヤルロックレバーバネ	SPRING	
28	SA2525001	1	オクリチヨウセツキ5	FEED REGULATOR 5	
29	016061031	2	アナトガリ6X10	SET SCREW SOCKET (CN) M6X10	
30	SA2526001	1	キリカエキレンカン	CONNECTING ROD	
31	SA2527001	1	ヘンシンジク	ECCENTRIC SHAFT	
32	012060636	1	アナヒラ6X6	SET SCREW SOCKET (FT) M6X6	
33	SA2528101	1	ダンネジ6	SHOULDER SCREW M6	
34	SA2529101	1	カエシヌイレバージクTR	SHAFT, R-LEVER TR	
35	048080342	1	トメワE8	RETAINING RING E8	
36	025100132	1	ヒラザガネシヨウ10	WASHER PLAIN S 10	
37	SA2530001	1	カンザ	SPACER	
38	S07374109	1	カエシヌイレバー	REVERSE STITCHING LEVER	
39	SA2531001	1	カエシヌイレバーオサエバネ	SPRING	
40	SA2541001	1	カエシヌイレバーイタ	REVERSE STITCHING LEVER PLATE	
41	SA6592001	1	シメネジM5	SCREW M5	
43	104821001	1	ゴムセン10.5	RUBBER CAP, 10.5	
44	062500816	2	ナベコ5X8	SCREW PAN M5X8	
45	SA2532001	1	ハンドルストツパ	STOPPER	
46	062501216	1	ナベコ5X12	SCREW PAN M5X12	
47	025050236	1	ヒラザガネチユウ5	WASHER PLAIN M 5	
48	S07376001	1	キリカエキバネ	FEED REGULATOR SPRING	
49	SA2533001	1	バネカケ	SPRING HOOK	
50	062060816	1	ナベコ6X8	SCREW PAN M6X8	
51	062501216	1	ナベコ5X12	SCREW PAN M5X12	
52	021500106	1	1シユナツト5	NUT 1 M5	

G . 逆転関係 / Quick reverse mechanism

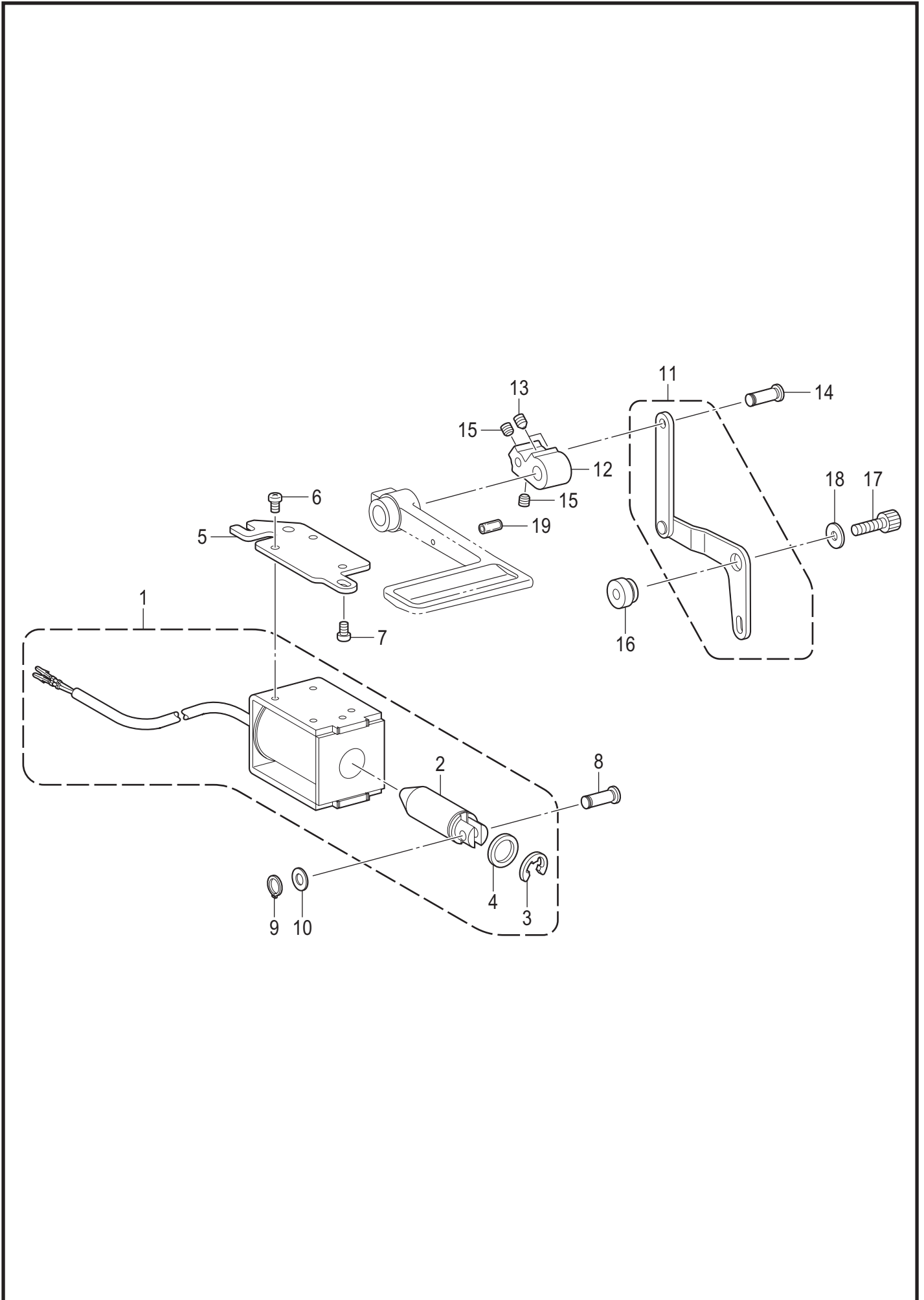

G . 逆転関係 / Quick reverse mechanism

REF.NO	CODE	Q'TY	品名	NAME OF PARTS	RM
1	SA3072001	1	ギヤクテンソレノイドクミ	QUICK REVERSE SOLENOID ASSY	
2	154729001	1	プランジヤ	PLUNGER	
3	154730001	1	トメワE15	RETAINING RING E15	
4	154731000	1	ゴムストツパー	RUBBER STOPPER	
5	SA2535101	1	ソレノイドドダイ	SOLENOID BRACKET	
6	062500812	3	ナベコ5X8	SCREW PAN M5X8	
7	062061016	2	ナベコ6X10	SCREW PAN M6X10	
8	SA2992001	1	レンケツピン	PIN	
9	048060142	1	トメワジクヨウC6	RETAINING RING EXTERNAL C6	
10	153138001	1	ザガネ	WASHER, PLAIN 6.5	
11	SA2536001	1	ソレノイドレバークミ	SOLENOID LEVER ASSY	
12	SA2540001	1	ギヤクテンレバー	QUICK REVERSE LEVER	
13	016061031	2	アナトガリ6X10	SET SCREW SOCKET (CN) M6X10	
14	SA2992001	1	レンケツピン	PIN	
15	012060636	2	アナヒラ6X6	SET SCREW SOCKET (FT) M6X6	
16	SA2539001	1	ソレノイドレバークミ	SOLENOID LEVER SHAFT	
17	018062032	1	アナボルト6X20	BOLT SOCKET M6X20	
18	149095001	1	ザガネ	WASHER, PLAIN 6	
19	153132000	1	ナイロンチューブ	NYLON TUBE, L=13.5	

H. 送り軸関係 / Feed shaft mechanism

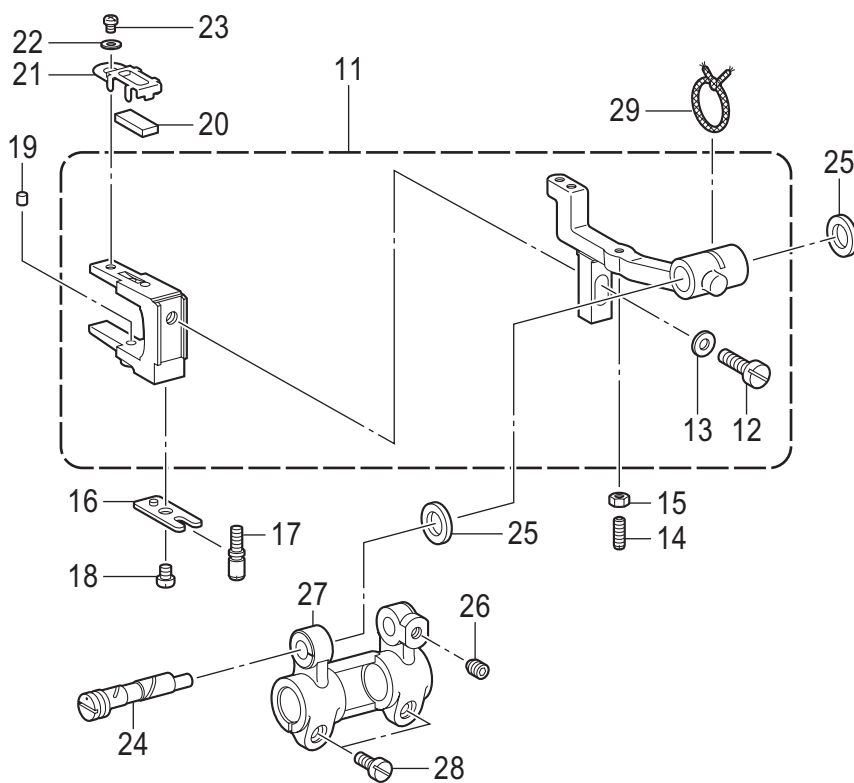
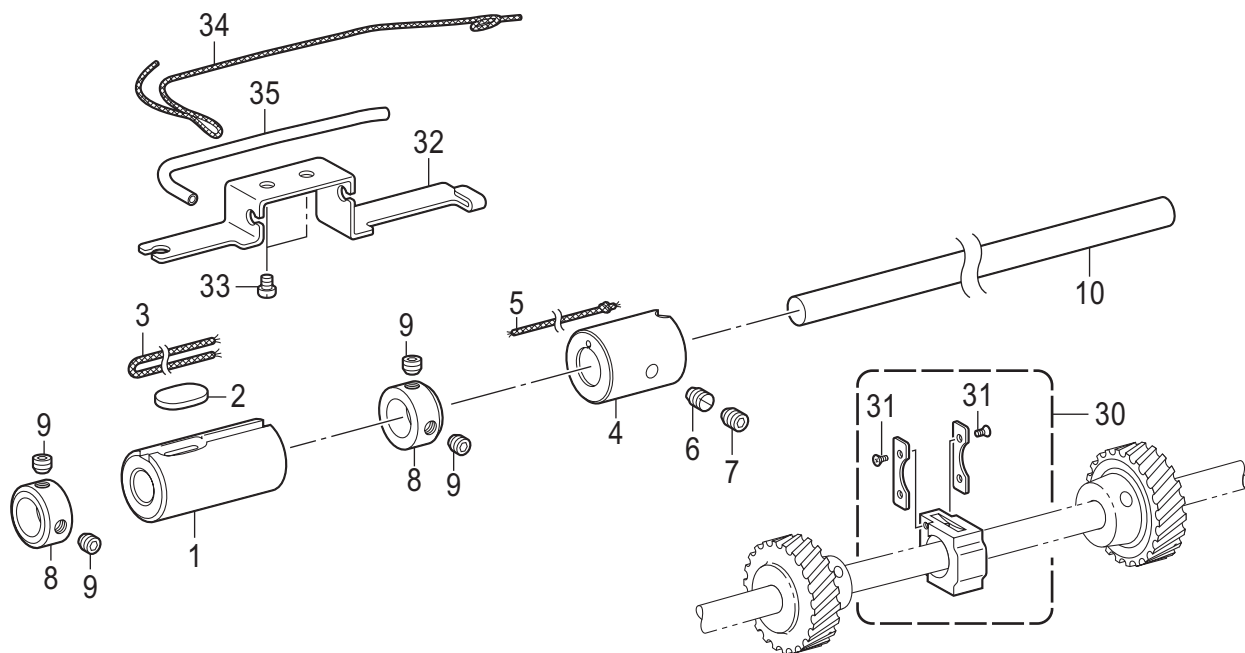

H. 送り軸関係 / Feed shaft mechanism

REF.NO	CODE	Q'TY	品名	NAME OF PARTS	RM
1	SA3855001	1	オクリジクメタルL	BUSH, L: F-ROCKER SHAFT	
2	SA3965001	1	フェルト	FELT	
3	SA4028001	1	クミヒモ4X4 L=220	WICK, 4X4 L=220	
4	SA2543001	1	オクリジクメタルR	FEED ROCKER SHAFT BUSH, R	
5	108802001	1	クミヒモ4X4	WICK, 4X4 L=250	
6	SA2544001	1	トメネジM6	SET SCREW M6	
7	012060636	1	アナヒラ6X6	SET SCREW SOCKET (FT) M6X6	
8	SA2546001	2	セツトカラ-	SET SCREW COLLAR	
9	S23651001	4	アナヒラ6X6ホソメ	SET SCREW SOCKET (FT) M6X6	
10	SA3840001	1	スイヘイオクリジク	FEED ROCKER SHAFT	
11	SA6150101	1	オクリダイTRフタマタクミ	FEED BAR TR FORK ASSY	
12	SA2927001	1	シメネジM6X14	SCREW, M6X14	
13	025060132	1	ヒラザガネシヨウ6	WASHER PLAIN S 6	
14	SA2566001	1	トメネジ3.5	SET SCREW, M3.5	
15	021350106	1	1シユナツト35	NUT 1 M3.5	
16	SA2553001	1	フタマタプレート	FORKED PLATE	
17	SA2554001	1	タカサチヨウセツネジ	ADJUSTING SCREW, HIGHT	
18	062400616	1	ナベコ4X6	SCREW PAN M4X6	
19	SA3990001	1	フェルト	FELT	
20	SA3887001	1	フェルト	FELT	
21	SA3888001	1	フェルトオサエ	FELT HOLDER	
22	025030132	1	ヒラザガネシヨウ3	WASHER PLAIN S 3	
23	062300416	1	ナベコ3X4	SCREW PAN M3X4	
24	SA2550001	1	オクリダイトリツケジク	FEED BAR SHAFT	
25	SA2551001	2	スラストリング	THRUST RING	
26	012060636	1	アナヒラ6X6	SET SCREW SOCKET (FT) M6X6	
27	SA2555001	1	スイヘイオクリダイウデ	FEED ROCKER BASE ARM	
28	SA2928001	2	シメネジM5X12	SCREW, M5X12	
29	SA4538001	1	クミヒモ3X3 L=200	WICK, 3X3 L=200	
30	SA2806001	1	オクリダイカクコマクミ	FEED BAR SLIDE BLOCK ASSY	
31	SA6308001	4	0サラコ3シユ2X4	SCREW FLAT #0 M2X4	
32	SA4009001	1	クミヒモササエ	WICK SUPPORT	
33	062400616	2	ナベコ4X6	SCREW PAN M4X6	
34	SA2724001	1	クミヒモ	WICK, L=400	
35	SA4011001	1	ビニルチューブ L=100	OIL TUBE, L=100	

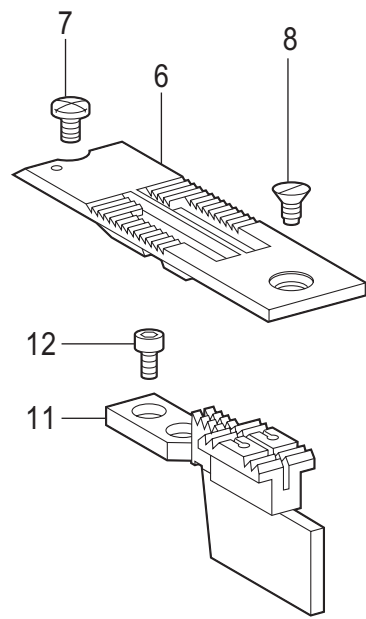
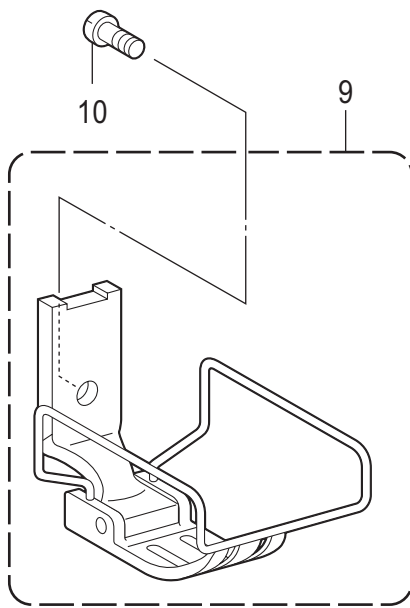
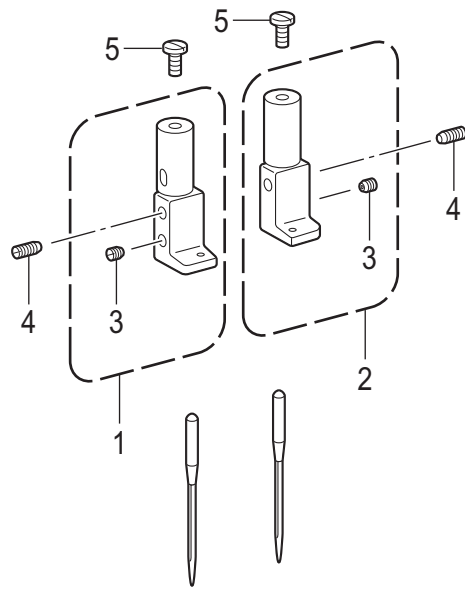

J . ゲージ関係 / Gauge parts

REF.NO	CODE	Q'TY	品名	NAME OF PARTS	RM
1	* P.59-62	1	ハリダキLクミ	NEEDLE CLAMP ASSY, L	
2	* P.59-62	1	ハリダキRクミ	NEEDLE CLAMP ASSY, R	
3	013660412	2	トメクボミ3.18-40X4	SET SCREW (CP) SM3.18-40X4	
4	S13085001	2	トメネジ3.18	SET SCREW, SM3.18	
5	149831101	2	アタマツキトメネジ3.18	SET SCREW, SM3.18	
6	* P.59-62	1	ハリイタ	NEEDLE PLATE	
7	S11244001	1	シメネジ4.37	SCREW, SM4.37	
8	100032004	1	サラネジ4.37	SCREW, FLAT SM4.37-40X8	
9	* P.59-62	1	オサエクミ	PRESSER FOOT ASSY	
10	113050001	1	シメネジ3.57	SCREW, SM3.57	
11	* P.59-62	1	オクリバ	FEED DOG	
12	S07494001	2	シメネジ3.18	SCREW, W/SOCKET SM3.18X7	

K1 . かま関係 / Rotary hook mechanism

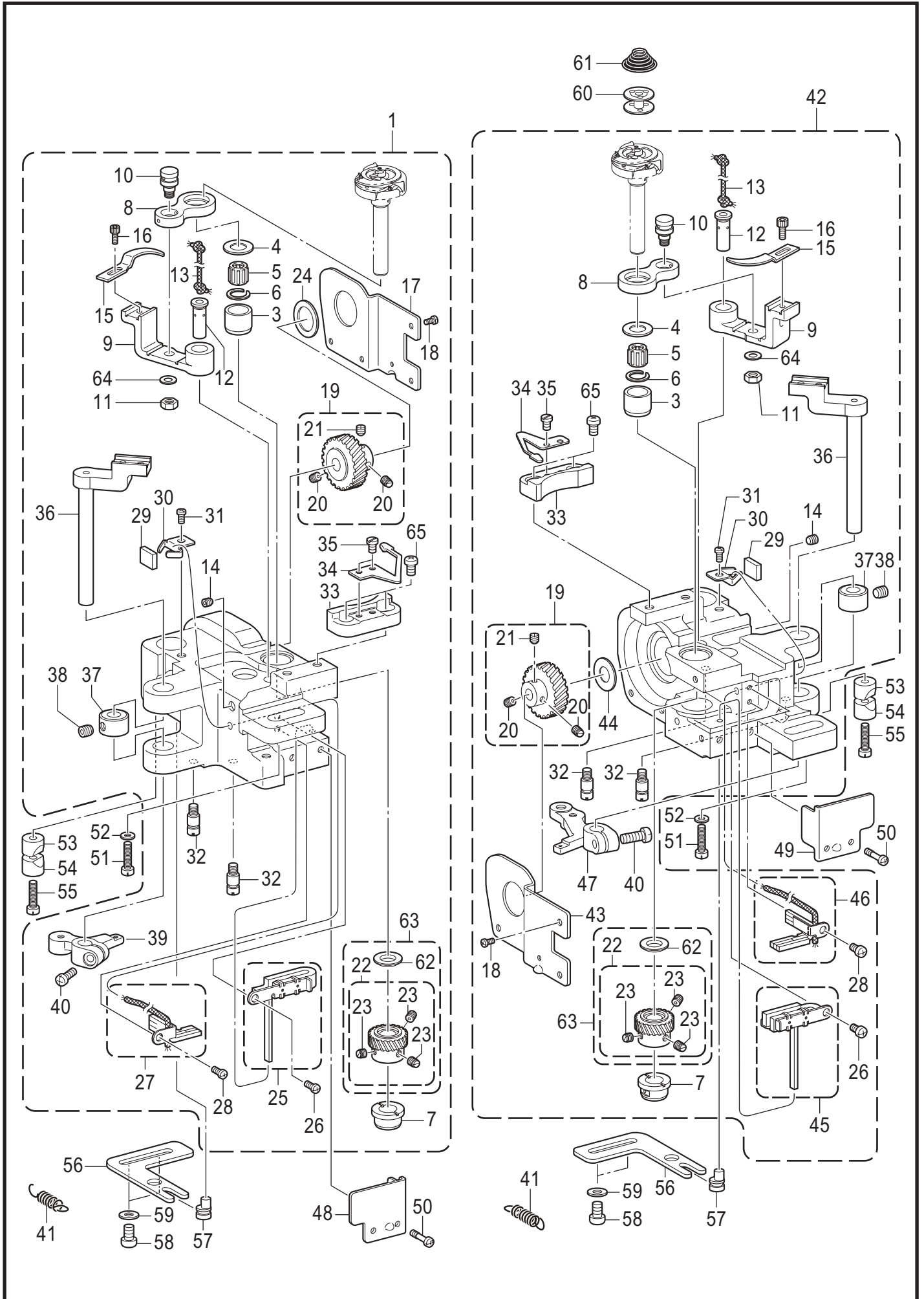

K1 . かま関係 / Rotary hook mechanism

REF.NO	CODE	Q'TY	品名	NAME OF PARTS	RM
1	SA4435201	1	カマドダイ845イトキリクミ	ROTARY HOOK BASE 845TR(L)	
3	SA4029001	1	カマジクメタルU	ROTARY HOOK SHAFT BUSH	
4	S09260001	1	スラストリングA< t=1.2 >	THRUST RING, A: 1.2MM < t=1.2 >	
4	SA4038001	1	スラストリング< t=1.0 >	THRUST RING < t=1.0 >	
4	S09261001	1	スラストリングB< t=1.4 >	THRUST RING, B: 1.4MM < t=1.4 >	
4	SA4444001	1	スラストリング0.8< t=0.8 >	THRUST RING 0.8MM < t=0.8 >	
5	S07420000	1	ニードルベアリング	NEEDLE BEARING	
6	S07419001	1	ストツプリング	RETAINING RING	
7	SA6474001	1	カマジクメタルD	ROTARY HOOK SHAFT BUSH	
8	SA3856001	1	オープナーリンク	OPENER LINK	
9	SA3859001	1	オープナーレバー	OPENER LEVER	
10	SA2560001	1	オープナーリンクジク	SHAFT, O-LINK	
11	021500316	1	3シュナツト5	NUT 3 M5	
12	SA3889101	1	オープナーレバージク	O-LEVER SHAFT	
13	SA4026001	1	クミヒモ4X4 L=100	WICK, 4X4 L=100	
14	012501031	1	アナヒラ5X10	SET SCREW SOCKET (FT) M5X10	
15	S38212001	1	オープナー	OPENER	
16	154965001	1	アナボルト3.57X8	BOLT, SOCKET SM3.57X8	
17	SA2562201	1	カマドダイカバーL	ROTARY HOOK BASE COVER L	
18	062300612	4	ナベコ3X6	SCREW PAN M3X6	
19	SA2572001	1	スパイラルギヤ ネジツキ	SPIRAL GEAR SCREW ASSY	
20	SA2574001	2	トメネジM6ホソメ	SET SCREW, (FT) M6	
21	SA2575001	1	トメネジM6ホソメ	SET SCREW, (FT) M6	
22	SA6301001	1	ピニオン ネジツキ	PINION GEAR SCREW ASSY	
23	SA2574001	3	トメネジM6ホソメ	SET SCREW, (FT) M6	
24	SA3054001	1	スラストザガネL	THRUST WASHER, L	
25	SA6424101	1	フェルトULクミ	FELT UL ASSY	
26	062400616	1	ナベコ4X6	SCREW PAN M4X6	
27	SA4044001	1	フェルトDLクミ	FELT DL ASSY	
28	062400616	1	ナベコ4X6	SCREW PAN M4X6	
29	SA4012001	1	フェルト	FELT	
30	SA3894001	1	フェルトオサエ	FELT SUPPORT	
31	062400616	1	ナベコ4X6	SCREW PAN M4X6	
32	SA2717001	2	ストツパネジ	STOPPER SCREW	
33	SA2676001	1	イドウハウケ	MOVABLE KNIFE BRACKET	
65	062400812	2	ナベコ4X8	SCREW PAN M4X8	
34	S07525000	1	シタイトホジバネ	SPRING PLATE	
35	141544001	2	シメネジ3.18	SCREW, SM3.18-40X3	
36	SA3912001	1	イドウハレバー	MOVABLE KNIFE LEVER	
37	SA2675001	1	セツトカラー	SET SCREW COLLAR	
38	S23651001	1	アナヒラ6X6ホソメ	SET SCREW SOCKET (FT) M6X6	
39	SA2671001	1	イトキリレバーL	THREAD TRIMMER LEVER, L	
40	062501212	1	ナベコ5X12	SCREW PAN M5X12	
62	SA6294101	1	スラストリング	THRUST RING	
63	SA6307101	1	ピニオンセット	PINION GEAR SET	
64	025710132	1	ヒラザガネショウ4.76	WASHER PLAIN S SM4.76	
42	SA4436201	1	カマドダイ845イトキリクミ	ROTARY HOOK BASE 845TR (R)	
3	SA4029001	1	カマジクメタルU	ROTARY HOOK SHAFT BUSH	
4	S09260001	1	スラストリングA< t=1.2 >	THRUST RING, A: 1.2MM < t=1.2 >	
4	SA4038001	1	スラストリング< t=1.0 >	THRUST RING < t=1.0 >	
4	S09261001	1	スラストリングB< t=1.4 >	THRUST RING, B: 1.4MM < t=1.4 >	
4	SA4444001	1	スラストリング0.8< t=0.8 >	THRUST RING 0.8MM < t=0.8 >	
5	S07420000	1	ニードルベアリング	NEEDLE BEARING	
6	S07419001	1	ストツプリング	RETAINING RING	
7	SA6474001	1	カマジクメタルD	ROTARY HOOK SHAFT BUSH	
8	SA3856001	1	オープナーリンク	OPENER LINK	
9	SA3859001	1	オープナーレバー	OPENER LEVER	
10	SA2560001	1	オープナーリンクジク	SHAFT, O-LINK	
11	021500316	1	3シュナツト5	NUT 3 M5	
12	SA3889101	1	オープナーレバージク	O-LEVER SHAFT	
13	SA4026001	1	クミヒモ4X4 L=100	WICK, 4X4 L=100	
14	012501031	1	アナヒラ5X10	SET SCREW SOCKET (FT) M5X10	

K1 . かま関係 / Rotary hook mechanism

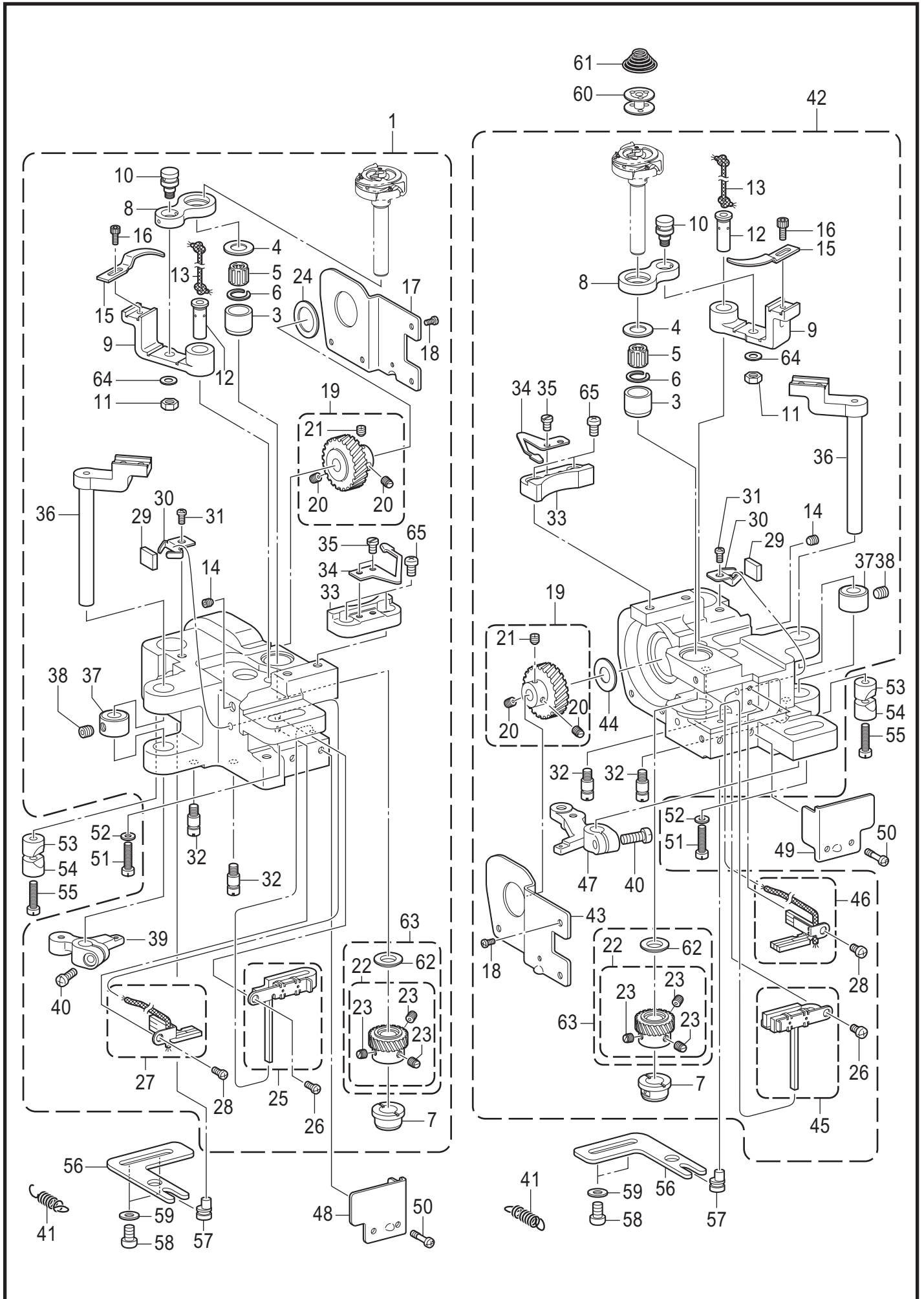

K1 . かま関係 / Rotary hook mechanism

REF.NO	CODE	Q'TY	品名	NAME OF PARTS	RM
15	S38212001	1	オープナー	OPENER	
16	154965001	1	アナボルト3.57X8	BOLT, SOCKET SM3.57X8	
43	SA2563301	1	カマダイカバ-R	ROTARY HOOK BASE COVER R	
18	062300612	4	ナベコ3X6	SCREW PAN M3X6	
19	SA2572001	1	スパイラルギヤ ネジツキ	SPIRAL GEAR SCREW ASSY	
20	SA2574001	2	トメネジM6ホソメ	SET SCREW, (FT) M6	
21	SA2575001	1	トメネジM6ホソメ	SET SCREW, (FT) M6	
22	SA6301001	1	ピニオン ネジツキ	PINION GEAR SCREW ASSY	
23	SA2574001	3	トメネジM6ホソメ	SET SCREW, (FT) M6	
44	SA2579001	1	スラストザガネ	SPECER	
45	SA6425101	1	フェルトURクミ	FELT UR ASSY	
26	062400616	1	ナベコ4X6	SCREW PAN M4X6	
46	SA4045001	1	フェルトDRクミ	FELT DR ASSY	
28	062400616	1	ナベコ4X6	SCREW PAN M4X6	
29	SA4012001	1	フェルト	FELT	
30	SA3894001	1	フェルトオサエ	FELT SUPPORT	
31	062400616	1	ナベコ4X6	SCREW PAN M4X6	
32	SA2717001	2	ストツパネジ	STOPPER SCREW	
33	SA2676001	1	イドウハウケ	MOVABLE KNIFE BRACKET	
65	062400812	2	ナベコ4X8	SCREW PAN M4X8	
34	S07525000	1	シタイトホジバネ	SPRING PLATE	
35	141544001	2	シメネジ3.18	SCREW, SM3.18-40X3	
36	SA3912001	1	イドウハレバー	MOVABLE KNIFE LEVER	
37	SA2675001	1	セツカラー	SET SCREW COLLAR	
38	S23651001	1	アナヒラ6X6ホソメ	SET SCREW SOCKET (FT) M6X6	
47	SA2670001	1	イトキリレバー-R	THREAD TRIMMER LEVER, R	
40	062501212	1	ナベコ5X12	SCREW PAN M5X12	
62	SA6294101	1	スラストリング	THRUST RING	
63	SA6307101	1	ピニオンセット	PINION GEAR SET	
64	025710132	1	ヒラザガネシヨウ4.76	WASHER PLAIN S SM4.76	
			<-405用>	<For -405>	
41	SA2826001	2	イトキリレバーバネ	SPRING, EXTENSION	
			<-403用>	<For -403>	
41	SA4458001	2	イトキリレバーバネB	SPRING, EXTENSION, B	
48	SA6462001	1	カマダイカバ-FL	ROTARY HOOK BASE COVER FL	
49	SA6463001	1	カマダイカバ-FR	ROTARY HOOK BASE COVER FR	
50	SA6417001	4	シメネジM4X12	SCREW M4X12	
51	SA2556001	2	シメネジM6X25	SCREW, M6X25	
52	115947101	2	ザガネ	WASHER PLAIN 6.35	
53	SA2722001	2	ピンチスリーブA	PINCH SLEEVE A	
54	SA2565001	2	ピンチスリーブB	PINCH SLEEVE B	
55	SA2556001	2	シメネジM6X25	SCREW, M6X25	
56	SA2567001	2	ハリスキチヨウセツイタ	NEEDLE UPPER POSITIONING PLATE	
57	SA2568001	2	ハリスキチヨウセツジク	NEEDLE UPPER POSITIONING SHAFT	
58	062061016	4	ナベコ6X10	SCREW PAN M6X10	
59	025060136	4	ヒラザガネシヨウ6	WASHER PLAIN S 6	
60	S01928151	2	ボビン	BOBBIN	
61	148602001	2	クウテンボウシバネ	ANTI-SPIN SPRING	

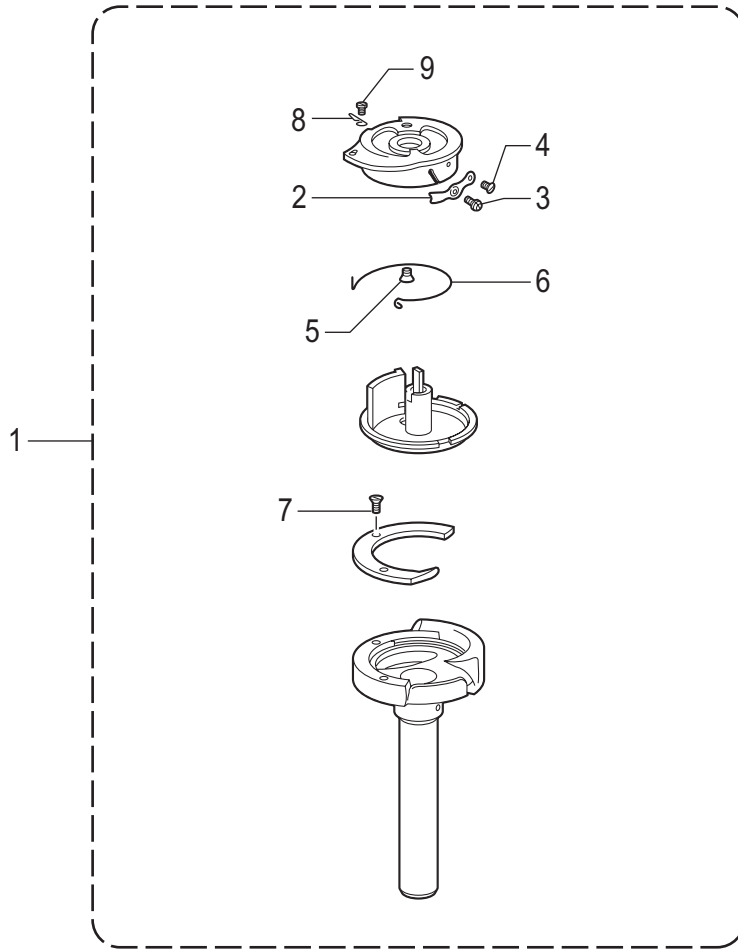

K2 . かま関係 / Rotary hook mechanism

REF.NO	CODE	Q'TY	品名	NAME OF PARTS	RM
1	SA1683111	1	カマハコクミ	ROTARY HOOK BOX ASSY	
2	151043001	1	チヨウシバネ	TENSION SPRING	
3	S01567001	1	チヨウシネジ	TENSION ADJUSTING SCREW	
4	S01568001	1	チヨウシバネトメネジ	SET SCREW	
5	151035001	1	タルミトリバネトメネジ	SET SCREW	
6	151034001	1	シタイトタルミトリバネ	TENSION SPRING	
7	151027001	2	ウチカマオサエトメネジ	SET SCREW	
8	159801001	1	イトオサエワイヤー	THREAD PRESSER WIRE	
9	159802001	1	シメネジ1.59X2	SCREW, SM1.59X2	

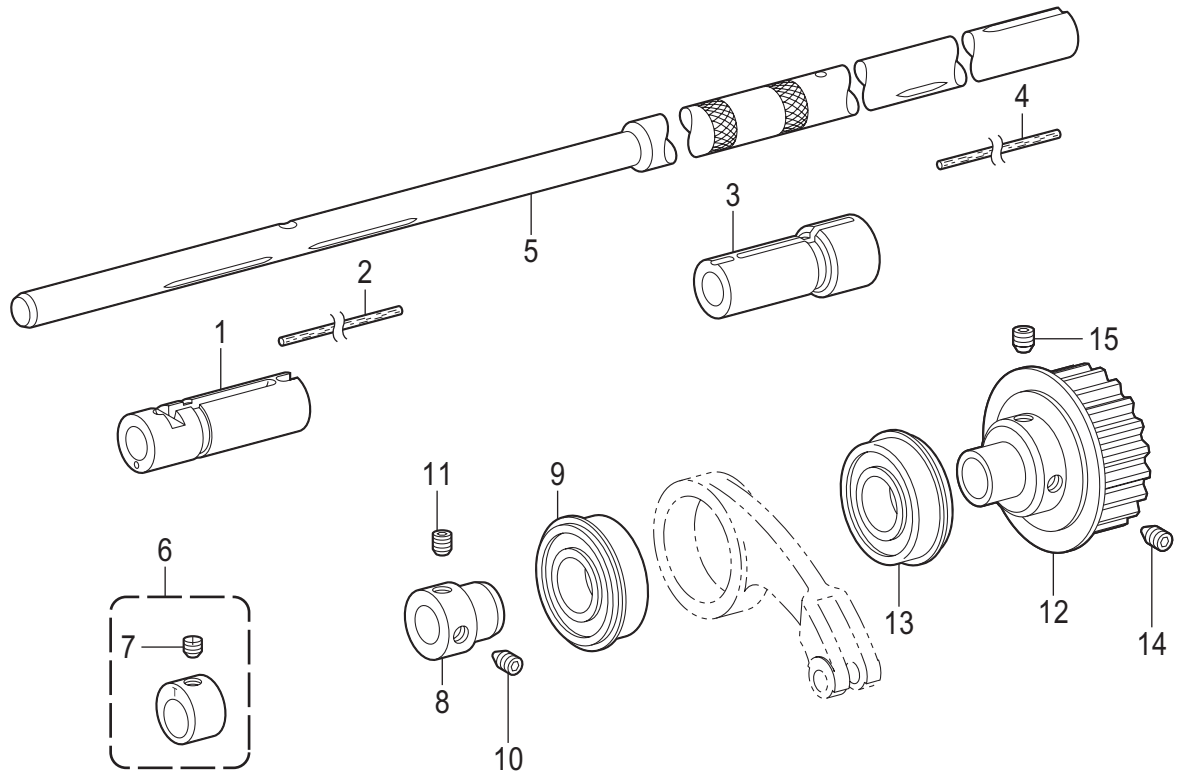

L . 下軸関係 / Lower shaft mechanism

REF.NO	CODE	Q'TY	品名	NAME OF PARTS	RM
1	SA3890001	1	カマドダイメタルL	ROTARY HOOK BASE BUSH, L	
2	SA4585001	1	フェルト	FELT	
3	SA3891001	1	カマドダイメタルR	ROTARY HOOK BASE BUSH, R	
4	SA4585001	1	フェルト	FELT	
5	SA2571001	1	シタジク	LOWER SHAFT	
6	SA2580101	1	ジヨウゲヘンシンリンTRクミ	F-LIFTING ECCENTRIC WHEEL ASSY	
7	SA2575001	1	トメネジM6ホソメ	SET SCREW (FT) M6	
8	SA2584001	1	タマジクウケブツシュ	BALL BEARING BUSH	
9	S38707001	1	タマジクウケ6004ZZNR	BALL BEARING, 6004ZZNR	
10	SA2585001	1	アナトガリ6X10ホソメ	SET SCREW, SOCKET (FT) M6	
11	S23651001	1	アナヒラ6X6ホソメ	SET SCREW SOCKET (FT) M6X6	
12	SA2587101	1	タイミングプーリDクミ	TIMING PULLEY ASSY, D	
13	158115001	1	タマジクウケ6204ZZNR	BALL BEARING, 6204ZZNR	
14	SA2585001	1	アナトガリ6X10ホソメ	SET SCREW, SOCKET (FT) M6	
15	SA4213001	1	アナトメネジ6X10ホソメ	SET SCREW SOCKET (CP) M6X10	

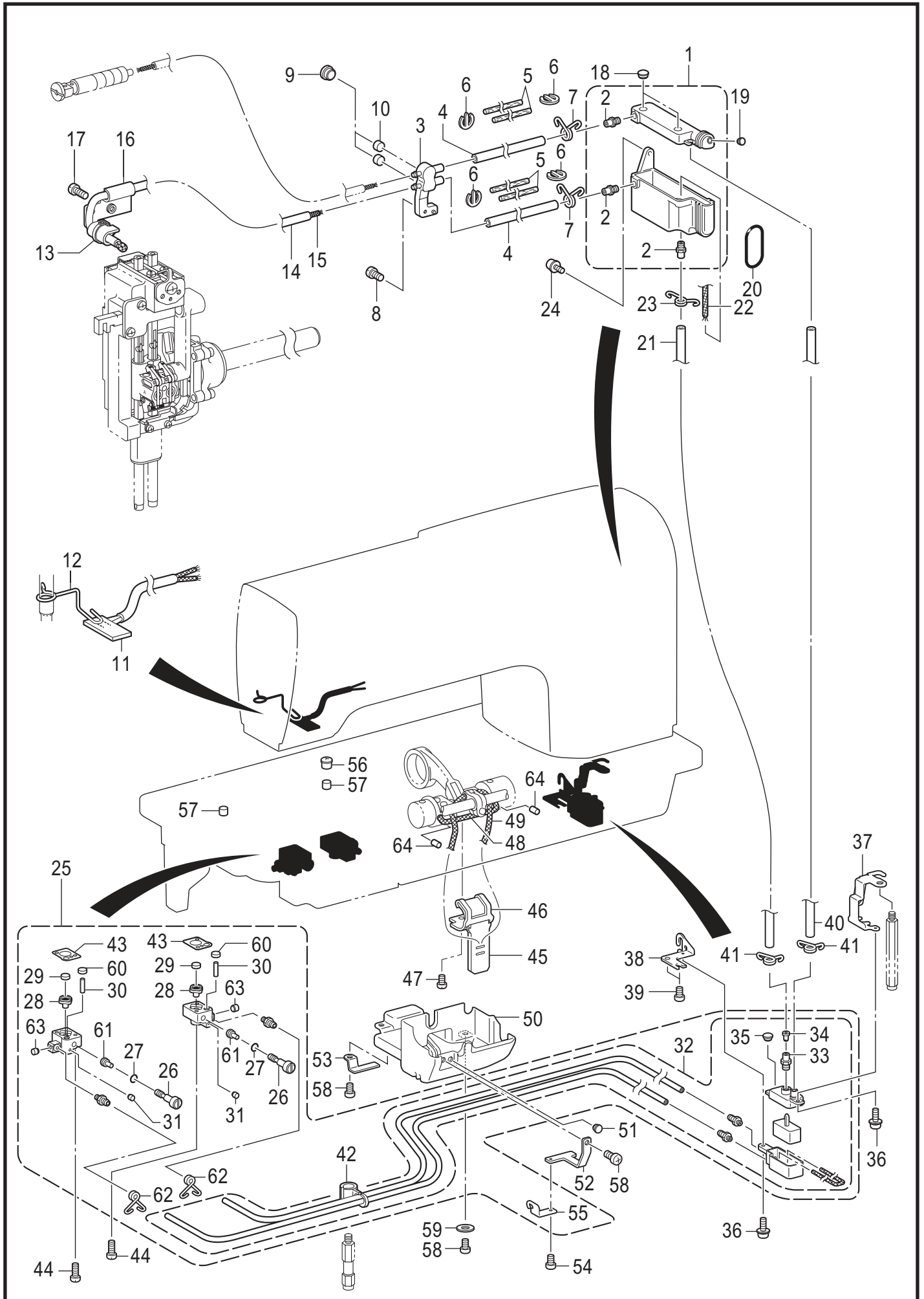

M. 給油潤滑関係 / Lubrication

REF.NO	CODE	Q'TY	品名	NAME OF PARTS	RM
1	SA2814201	1	オイルタンククミ	OIL TANK ASSY	
2	SA3040001	3	オイルクチ	OIL FEEDING PIPE	
3	SA3946001	1	キュウユタ-ミナル	OIL TERMINAL	
4	SA2956001	2	ビニルチューブ	OIL TUBE, L=135	
5	SA2957001	4	フェルト	FELT	
6	SA6178001	4	クリップ	CLIP	
7	SA3055101	2	チューブストツパー	TUBE CLIP	
8	062500816	1	ナベコ5X8	SCREW PAN M5X8	
9	SA2929001	2	ゴムセン12.5	RUBBER CAP, 12.5	
10	S38266000	2	カマジクフェルト	ROTARY HOOK SHAFT FELT	
11	SA5224001	1	フェルトクミ	FELT ASSY	
12	SA4033101	1	フェルトオサエ	FELT SUPPORT	
13	228475000	1	ケツソクバンド1.9X80	FASTENING BAND 1.9X80	
14	S49623000	1	ビニルチューブ	OIL TUBE, L=280	
15	SA5293001	1	クミヒモ	WICK L=410	
16	SA5154201	1	キュウユササエ	OIL SUPPORT	
17	062501016	1	ナベコ5X10	SCREW PAN M5X10	
18	SA2929001	2	ゴムセン12.5	RUBBER CAP, 12.5	
19	104450101	1	ゴムセン8	RUBBER CAP, 8	
20	081038070	1	リングP38	O RING P38	
21	SA2723001	1	ビニルチューブ	OIL TUBE, L=210	
22	SA2724001	1	クミヒモ	WICK, L=400	
23	SA3055101	1	チューブストツパー	TUBE CLIP	
24	0A5501006	2	+ナベザクミ5X10DB	SCREW PAN (S/P WASHER) M5X10	
25	SA7540001	1	キュウユブロツクセット	OIL BLOCK SET	
26	SA6475001	2	オイルチヨウセツネジ	OIL ADJUSTING SCREW	
27	081004070	2	リングP4	O RING P4	
28	SA6468001	2	ゴムパツキン	RUBBER PACKING	
29	SA6423001	2	カマジクフェルト	ROTARY HOOK SHAFT FELT	
30	SA6415001	2	クミヒモ	WICK L=80	
31	142274101	2	ゴムセン4.2	RUBBER CAP, 4.2	
32	SA7548001	1	サブタンクセット	SUB-TANK SET	
33	SA3040001	1	オイルクチ	OIL FEEDING PIPE	
34	SA3060001	1	バルブパツキン	VALVE PACKING	
35	104450101	1	ゴムセン8	RUBBER CAP, 8	
36	0A4400806	2	+ナベザクミ4X8DA	SCREW PAN (S/P WASHER) M4X8	
37	SA3045201	1	サブタンクトリツケイタA	SUB-TANK SETTING PLATE A	
38	SA3046001	1	サブタンクトリツケイタB	SUB-TANK SETTING PLATE, B	
39	062060816	2	ナベコ6X8	SCREW PAN M6X8	
40	SA3044001	1	ビニルチューブ	OIL TUBE, L=242	
41	SA3055101	2	チューブストツパー	TUBE CLIP	
42	SA6472001	1	チューブササエ	TUBE SUPPORT	
43	SA3923101	2	カマドダイDパツキン	ROTARY HOOK BASE D PACKING	
44	062401616	4	ナベコ4X16	SCREW PAN M4X16	
45	SA2604001	1	キリカエキフェルト	FEED REGULATOR FELT	
46	SA2605001	1	フェルトオサエイタ	FELT SUPPORT	
47	062500616	1	ナベコ5X6	SCREW PAN M5X6	
48	109405001	1	クミヒモ4X4	WICK 4X4 (L=100)	
49	108801001	1	クミヒモ4X4	WICK, 4X4 L=350	
50	SA2606101	1	オイルカバー	OIL COVER	
51	104450101	1	ゴムセン8	RUBBER CAP, 8	
52	SA3048101	1	チューブオサエA	TUBE SUPPORT, A	
53	SA3049001	1	チューブオサエB	TUBE SUPPORT, B	
54	062400616	1	ナベコ4X6	SCREW PAN M4X6	
55	SA6473001	1	チューブガイド	TUBE GUIDE	
56	140890009	1	オイルカツプ	OIL CAP	
57	112753001	2	フェルト	FELT	
58	062061016	3	ナベコ6X10	SCREW PAN M6X10	
59	025060236	1	ヒラザガネチュウ6	WASHER PLAIN M 6	
60	SA6423001	2	カマジクフェルト	ROTARY HOOK SHAFT FELT	

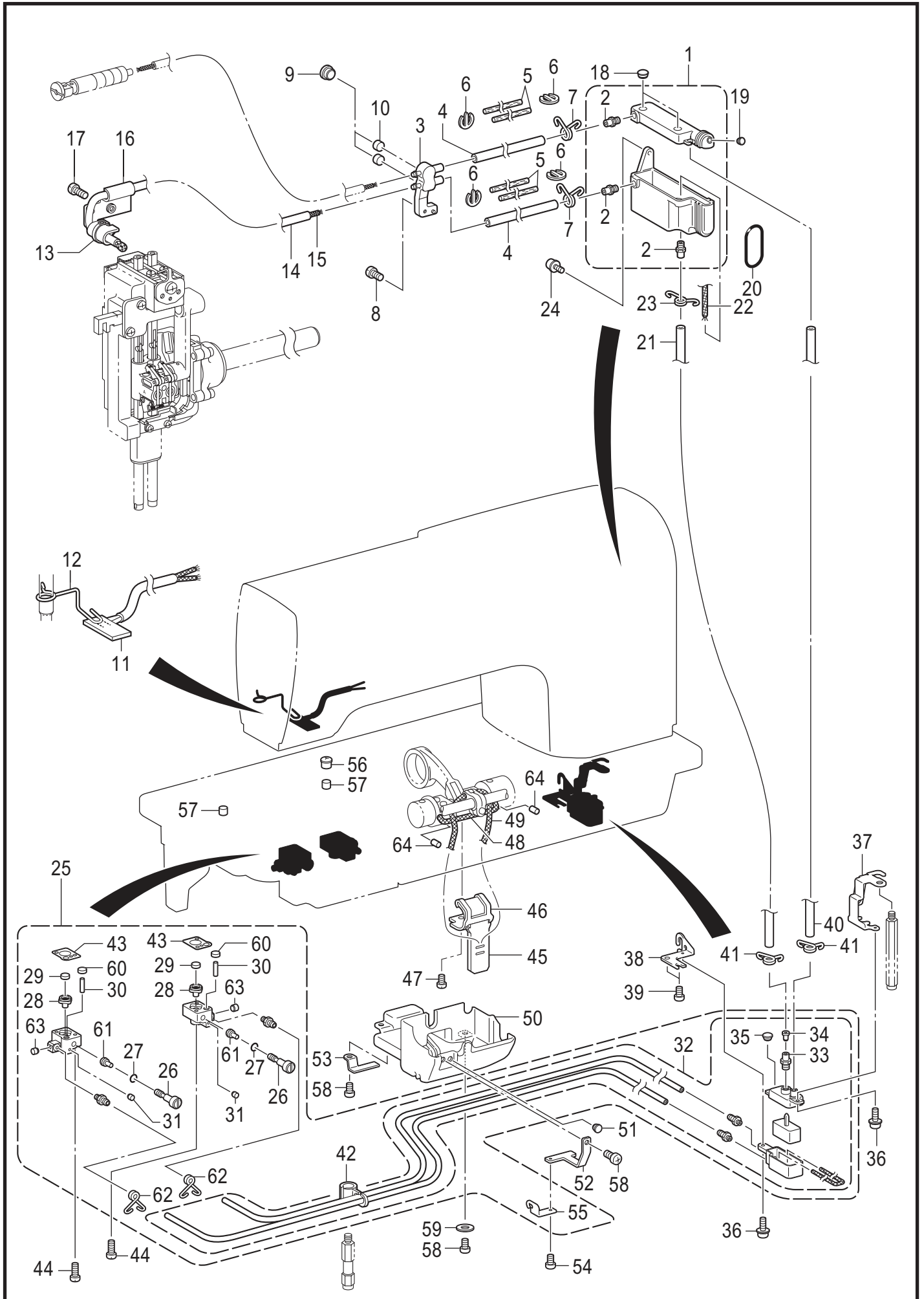

M. 給油潤滑関係 / Lubrication

REF.NO	CODE	Q'TY	品名	NAME OF PARTS	RM
61	SA6416001	2	ゴムオサエ	RUBBER PRESSER	
62	SA6414001	2	チューブストツパー	TUBE CLIP	
63	140327001	2	ゴムセン6.3	RUBBER CAP, 6.3	
64	148743001	2	フェルト	FELT	

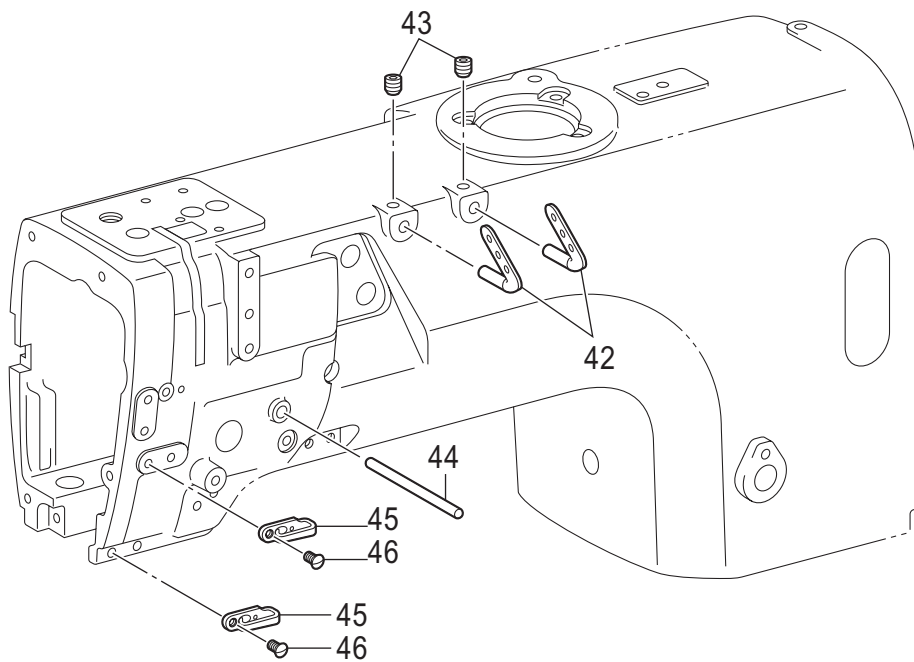
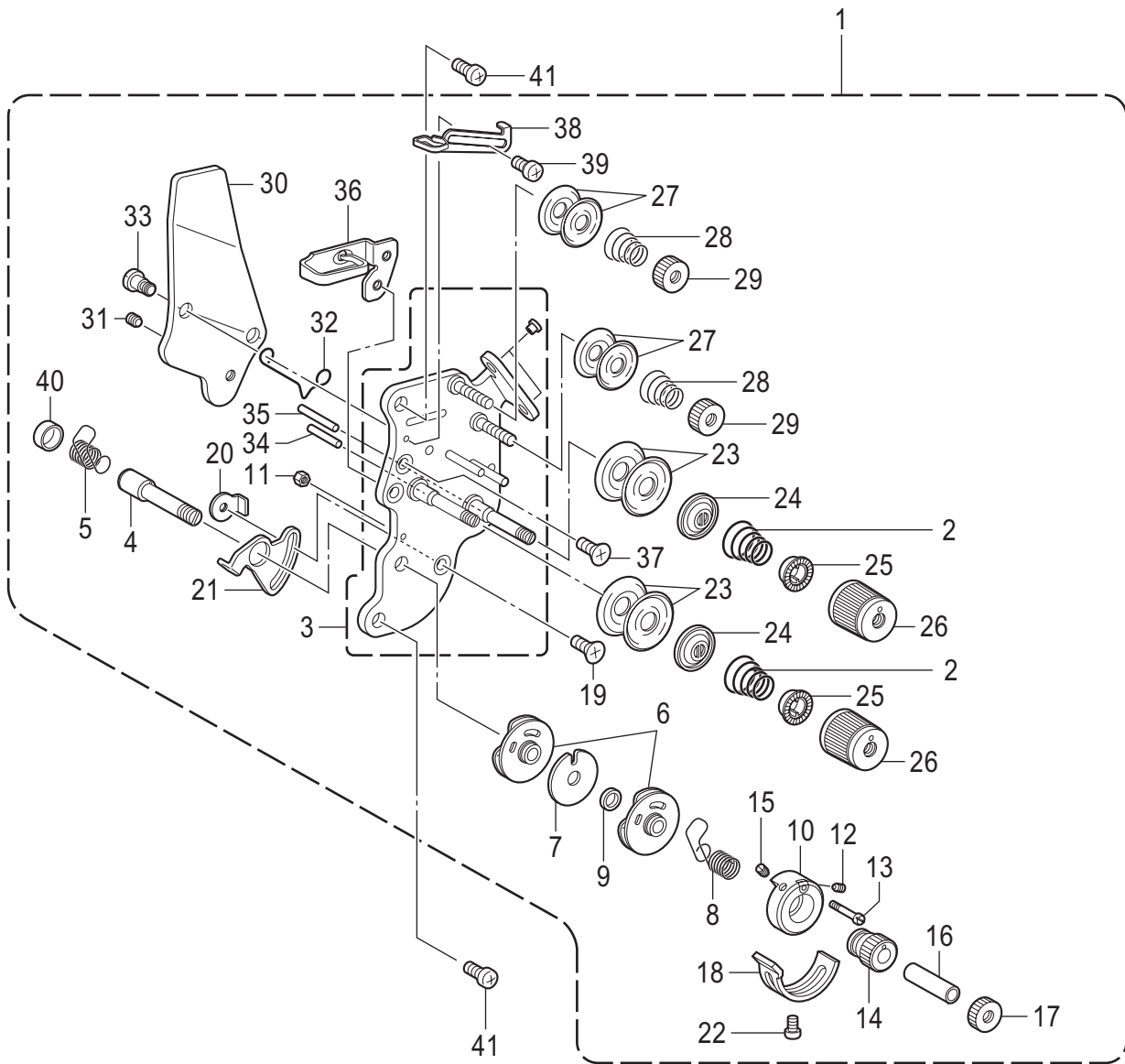

N . 糸通し関係 / Threading mechanism

REF.NO	CODE	Q'TY	品名	NAME OF PARTS	RM
			<-403用>	<For -403>	
1	SA3417301	1	ウワイトチヨウシクミ-3	UPPER THREAD TENSION ASSY -3	
2	SA3415001	2	イトチヨウシバネL	TENSION SPRING, L	
			<-405用>	<For -405>	
1	SA2607301	1	ウワイトチヨウシクミ-5	UPPER THREAD TENSION ASSY -5	
2	SA3416101	2	イトチヨウシバネLL	TENSION SPRING LL	
3	SA4212001	1	イトチヨウシダイクミ	TENSION PLATE ASSY	
4	SA2613001	1	チヨウシジク	TENSION STUD	
5	SA2614201	1	イトトリバネL	THREAD TAKE-UP SPRING L	
6	SA2615001	2	イトトリバネアンナイクミ	GUIDE ASSY, T/TAKE-UP SPRING	
7	SA2619001	1	スペーサー	SPACER	
8	SA2623201	1	イトトリバネR	THREAD TAKE-UP SPRING R	
9	SA2620001	1	カラ-	COLLAR	
10	SA2621001	1	ストツパウケ	STOPPER SUPPORT	
11	021300106	1	1シユナツト3	NUT 1 M3	
12	SA2626001	1	トメネジ3.5	SET SCREW, (CP) M3.5	
13	SA2624001	1	バネアンナイトメネジ	SPRING GUIDE SET SCREW	
14	SA2625001	1	チヨウセツツマミ	ADJUSTING THUMB	
15	SA2626001	1	トメネジ3.5	SET SCREW, (CP) M3.5	
16	SA2627001	1	カラ-	COLLAR	
17	SA2628001	1	イトチヨウシナツト	TENSION NUT	
18	SA2629001	1	イトトリバネストツパ	STOPPER	
19	061350616	1	サラコ35X6	SCREW FLAT M3.5X6	
20	SA2824001	1	マワリドメナツトM3.5	NUT, WHIRL-STOP M3.5	
21	SA2630001	1	イトトリバネストツパ	STOPPER	
22	062350512	1	ナベコ35X5	SCREW PAN M3.5X5	
23	145446001	4	イトチヨウシサラ	DISC, TENSION	
24	159805001	2	イトチヨウシサラオサエ	TENSION DISC PRESSER	
25	S20681000	2	チヨウシバネウエザガネ	WASHER	
26	S20682105	2	イトチヨウシナツト	TENSION NUT	
27	144504001	4	イトアンナイサラ	THREAD GUIDE DISC	
28	154560101	2	プレテンションバネA	PRE-TENSION SPRING A	
29	155510001	2	イトチヨウシナツト	TENSION NUT	
30	SA2632001	1	イトユルメイタ	TENSION RELEASE PLATE	
31	012500536	1	アナヒラ5X5	SET SCREW SOCKET (FT) M5X5	
32	S38274001	1	イトユルメバネ	T-RELEASE SPRING	
33	SA2633001	2	ダンネジ3.5	SHOULDER SCREW, M3.5	
34	SA4506001	1	イトユルメピンL	TENSION RELEASE PIN, L	
35	SA4507001	1	イトユルメピンR	TENSION RELEASE PIN, R	
36	SA2634001	1	ア-ムイトアンナイU	THREAD GUIDE, U: ARM	
37	061350616	2	サラコ35X6	SCREW FLAT M3.5X6	
38	SA2635001	1	イトリヨウチヨウセイ	THREAD QUANTITY ADJUST	
39	062300616	1	ナベコ3X6	SCREW PAN M3X6	
40	SA6378001	1	キャツブ	CAP	
41	062500816	2	ナベコ5X8	SCREW PAN M5X8	
42	SA2636001	2	ミツメイトカケ	THREAD RETAINER	
43	012060636	2	アナヒラ6X6	SET SCREW SOCKET (FT) M6X6	
44	SA2637001	1	イトユルメジク	BAR, TENSION RELEASE	
45	SA2638001	2	ア-ムイトアンナイM	THREAD GUIDE, M: ARM	
46	SA2640001	2	サラネジ5X8	SCREW FLAT M5X8	

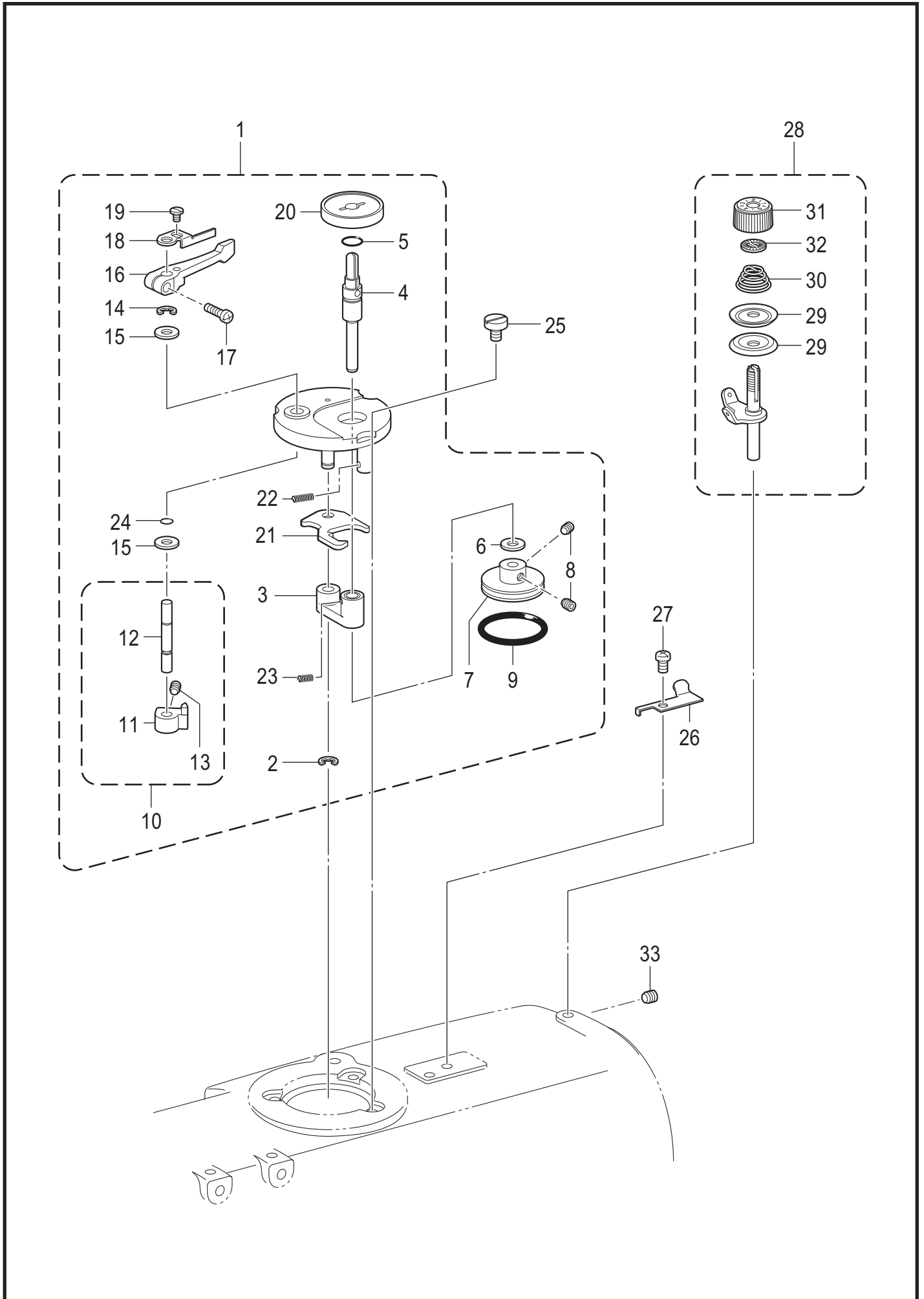

P . 糸巻関係 / Bobbin winder mechanism

REF.NO	CODE	Q'TY	品名	NAME OF PARTS	RM
1	SA1971101	1	イトマキユニット	BOBBIN WINDER UNIT	
2	048040342	1	トメワE4	RETAINING RING, E4	
3	SA1975001	1	イトマキジクウケクミ	B-WINDER SHAFT SUPPORT ASSY	
4	SA1978001	1	イトマキジク	BOBBIN WINDER SHAFT	
5	081009070	1	OリングP9	O RING, P9	
6	025060136	1	ヒラザガネシヨウ6	WASHER, PLAIN S 6	
7	SA1980001	1	イトマキクルマ	BOBBIN WINDER WHEEL	
8	012500536	2	アナヒラ5X5	SET SCREW, SOCKET (FT) M5X5	
9	S25789000	1	ゴムワ29	RUBBER RING, 29	
10	SA1981101	1	ボビンオサエカムクミ	BOBBIN PRESSER CAM ASSY	
11	SA1982101	1	ボビンオサエカム	BOBBIN PRESSER CAM	
12	SA1983001	1	イトマキウデジク	BOBBIN WINDER ARM SHAFT	
13	012500536	1	アナヒラ5X5	SET SCREW, SOCKET (FT) M5X5	
14	048040342	1	トメワE4	RETAINING RING, E4	
15	025060136	2	ヒラザガネシヨウ6	WASHER, PLAIN S 6	
16	SA1984001	1	ボビンオサエウデ	BOBBIN PRESSER ARM	
17	062401216	1	ナベコ4X12	SCREW, PAN M4X12	
18	SA1985001	1	ボビンオサエ	BOBBIN PRESSER	
19	S23418002	1	シメネジ4X5	SCREW, M4X5	
20	SA1988001	1	ボビンウケ	BOBBIN SUPPORT	
21	SA1989001	1	イトマキレバー	BOBBIN WINDER LEVER	
22	SA1990101	1	モドシバネ	SPRING	
23	SA1991001	1	イトマキダイバネ	BOBBIN WINDER BASE SPRING	
24	SA2190001	1	OリングSS5	O RING, SS5	
25	SA1992101	3	イトマキコテイネジ	BOBBIN WINDER FIXED SCREW	
26	SA1360101	1	メス	KNIFE	
27	062500616	1	ナベコ5X6	SCREW, PAN M5X6	
28	SA1994101	1	イトマキチヨウシクミ	BOBBIN WINDER TENSION ASSY	
29	145446002	2	イトチヨウシサラ	DISC, TENSION	
30	100401022	1	イトチヨウシバネ	TENSION SPRING	
31	S31032001	1	イトチヨウシナツト	TENSION NUT	
32	S12441001	1	チヨウシバネウエザガネ	WASHER	
33	012500536	1	アナヒラ5X5	SET SCREW, SOCKET (FT) M5X5	

Q . 糸切り関係 / Thread trimmer mechanism

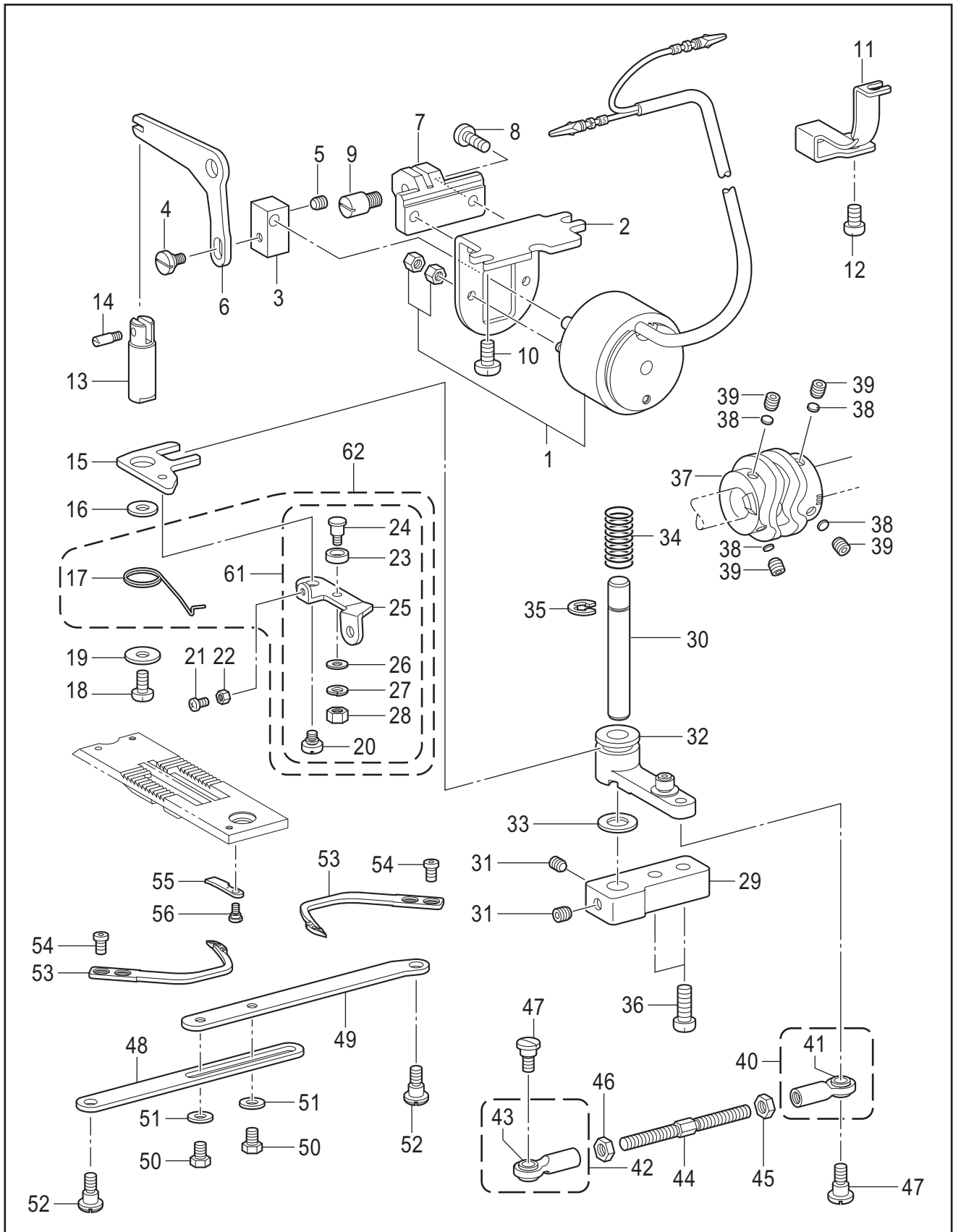

Q. 糸切り関係 / Thread trimmer mechanism

REF.NO	CODE	Q'TY	品名	NAME OF PARTS	RM
1	SA2642001	1	イトキリソレノイド	THREAD TRIMMER SOLENOID	
2	SA2643001	1	ソレノイドシジイタ	SOLENOID BRACKET	
3	SA2644001	1	ソレノイドツギテ	SOLENOID JOINT	
4	SA2645001	1	ダンネジM5	SHOULDER SCREW, M5	
5	012500536	1	アナヒラ5X5	SET SCREW SOCKET (FT) M5X5	
6	SA2646001	1	ソレノイドレバー	SOLENOID LEVER	
7	SA2728001	1	ソレノイドレバーウケ	SOLENOID LEVERB RACKET	
8	062501016	2	ナベコ5X10	SCREW PAN M5X10	
9	SA2647001	1	ソレノイドレバージク	SOLENOID LEVER SHAFT	
10	062061012	2	ナベコ6X10	SCREW PAN M6X10	
11	SA2648001	1	コードオサエ	CORD HOLDER	
12	062060816	1	ナベコ6X8	SCREW PAN M6X8	
13	SA2651001	1	イトキリジク	DRIVING ROD	
14	148546001	1	プランジヤピン	PLUNGER PIN	
15	SA2652101	1	イトキリジクイタ	DRIVING ROD PLATE, TR	
16	SA2860001	1	ザガネ	WASHER	
17	SA6395001	1	イトユルメレバーバネ	SPRING	
18	062501016	1	ナベコ5X10	SCREW PAN M5X10	
19	116662003	1	ザガネ	WASHER	
20	SA2655001	1	ダンネジM4	SHOULDER SCREW, M4	
21	062351216	1	ナベコ35X12	SCREW PAN M3.5X12	
22	021350106	1	1シュナツト35	NUT 1 M3.5	
23	SA6392001	1	イトユルメコロ	ROLLER	
24	SA6393001	1	イトユルメコロジク	ROLLER SHAFT	
25	SA6394001	1	イトユルメレバー	TENSION RELEASE LEVER	
26	113431002	1	ザガネ	WASHER, PLAIN	
27	028050246	1	バネザガネ2-5	WASHER SPRING 2-5	
28	021500106	1	1シュナツト5	NUT 1 M5	
29	SA2657001	1	シュレバージクササエ	MAIN LEVER SUPPORT SHAFT	
30	SA2658001	1	シュレバージク	MAIN LEVER SHAFT	
31	012060636	2	アナヒラ6X6	SET SCREW SOCKET (FT) M6X6	
32	SA2659001	1	シュレバークミ	MAIN LEVER ASSY	
33	148559100	1	ゴム	RUBBER	
34	S07509001	1	シュレバーバネ	MAIN LEVER SPRING	
35	048070342	1	トメワE7	RETAINING RING E7	
36	062061616	2	ナベコ6X16	SCREW PAN M6X16	
37	SA2661001	1	イトキリカム	THREAD TRIMMER CAM	
38	SA2378001	4	カンザ4.8	SPACER, 4.8	
39	S25236001	4	アナヒラ6X10ホソメ	SET SCREW SOCKET (FT) M6X10	
40	SA2663001	1	タマツギテRクミ	ROUND JOINT ASSY R	
41	141331002	1	キュウメンブシュ	BUSH	
42	SA2665001	1	タマツギテLクミ	ROUND JOINT ASSY L	
43	141331002	1	キュウメンブシュ	BUSH	
44	SA2667001	1	ナガサチヨウセツレンカン	L-ADJUSTING CONNECTING ROD	
45	021060306	1	3シュナツト6	NUT 3 M6	
46	SA2668001	1	ナツト6ヒダリ	NUT M6 LEFT	
47	SA2669001	2	タマツギテダンネジ	SHOULDER SCREW, SM5.95-28	
48	SA2672001	1	イトキリレンカンR	T-TRIMMER CONNECTING ROD, R	
49	SA2673001	1	イトキリレンカンL	T-TRIMMER CONNECTING ROD, L	
50	017500812	2	ボルト5X8	BOLT M5X8	
51	025050236	2	ヒラザガネチユウ5	WASHER PLAIN M 5	
52	SA2645001	2	ダンネジM5	SHOULDER SCREW, M5	
53	S07526301	2	イドウハ	MOVABLE KNIFE	
54	148536001	4	シメネジ4.37	SCREW, W/SOCKET SM4.37-40X4.2	
55	S07527001	2	コテイハ	FIXED KNIFE	
56	148539101	2	ダンネジ2.38	SHOULDER SCREW, SM2.38	
61	SA8364001	1	イトユルメレバークミ	TENSION RELEASE LEVER ASSY	
62	SA8365001	1	イトユルメレバーセット	TENSION RELEASE LEVER SET	
57	S38687000	1	コネクタ5557-14R	CONNECTOR, 5557-14R	
58	SA1998001	1	アースセンクミ	GROUND WIRE ASSY	
59	062500816	1	ナベコ5X8	SCREW PAN M5X8	
60	340400001	2	ユニタイバンド	BEAD BAND	

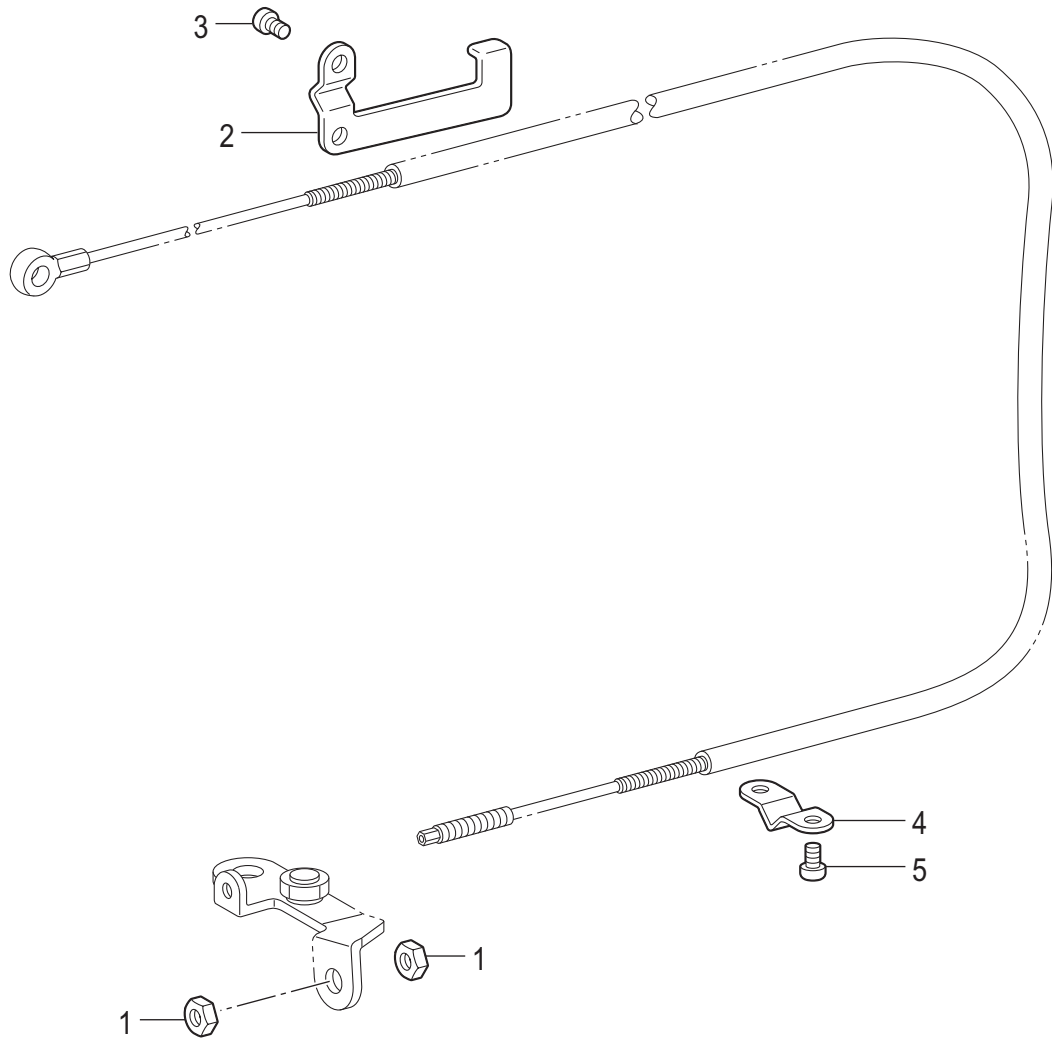

R . 糸緩め関係 / Tension release mechanism

REF.NO	CODE	Q'TY	品名	NAME OF PARTS	RM
1	110161004	2	ナツト4.76	NUT, SM4.76	
2	SA2678001	1	イトユルメワイヤ-オサエ	TENSION RELEASE WIRE HOLDER	
3	062500816	2	ナベコ5X8	SCREW PAN M5X8	
4	SA2679001	1	イトユルメワイヤ-オサエ	TENSION RELEASE WIRE HOLDER	
5	062060816	2	ナベコ6X8	SCREW PAN M6X8	

S . 糸払い関係 / Thread wiper mechanism

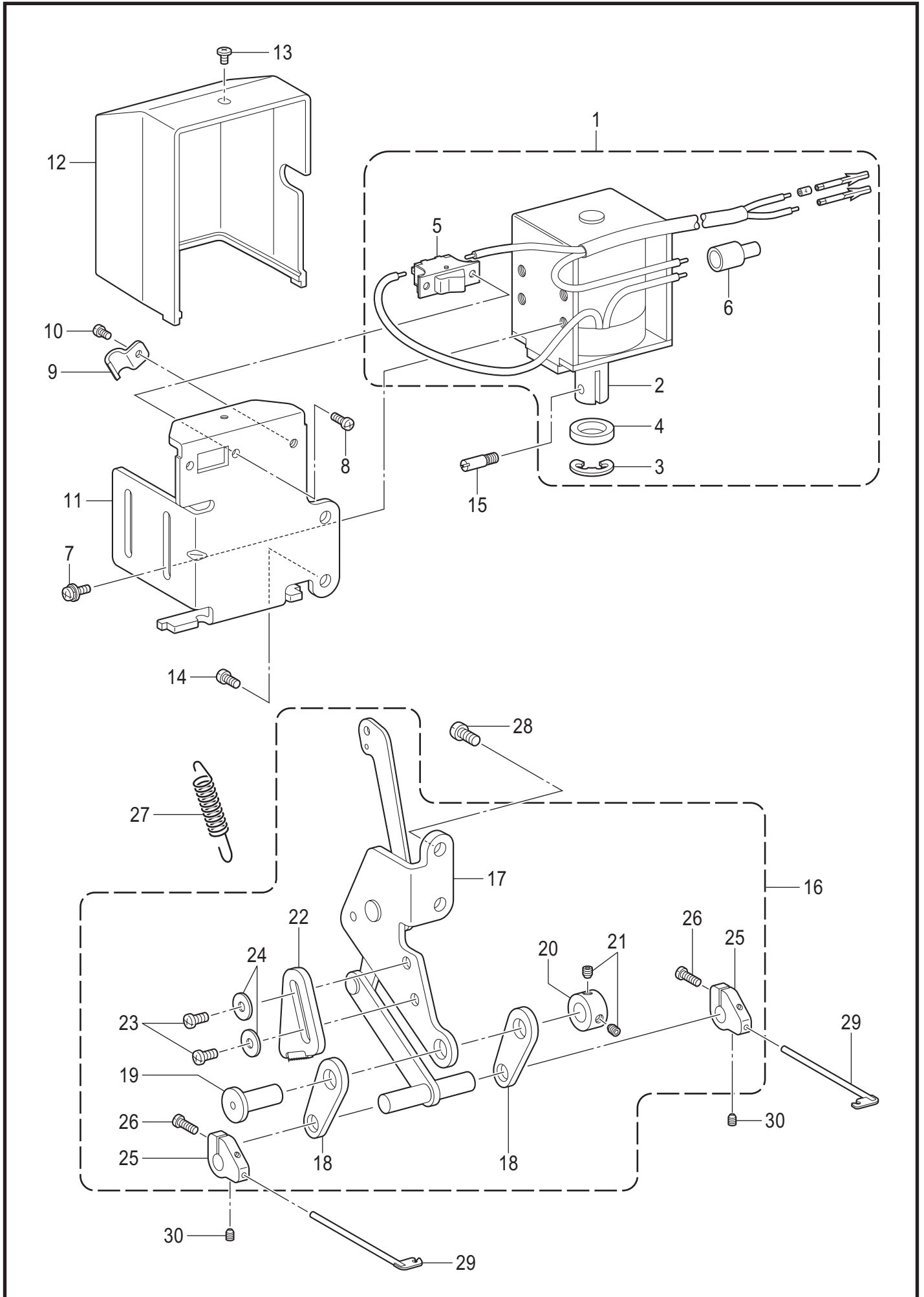

S . 糸払い関係 / Thread wiper mechanism

REF.NO	CODE	Q'TY	品名	NAME OF PARTS	RM
1	SA2680001	1	イトハライソレノイドクミ	THREAD WIPER SOLENOID ASSY	
2	148511001	1	プランジャ	PLUNGER	
3	048090342	1	トメワE9	RETAINING RING E9	
4	S38426000	1	プランジャゴム	PLUNGER RUBBER	
5	S02664001	1	イトハライスイッチ	THREAD WIPER SWITCH	
6	S02665000	1	ヘイタンセツゾクシ	TERMINAL CONNECTOR	
7	S39048001	4	ナベザクミM4X10	SCREW, PAN (S/P W) M4X10	
8	062300616	2	ナベコ3X6	SCREW PAN M3X6	
9	140647101	1	コードオサエ	CORD HOLDER	
10	062400616	1	ナベコ4X6	SCREW PAN M4X6	
11	SA2732001	1	ソレノイドホジイタ	SOLENOID HOLDING PLATE	
12	SA2696001	1	ソレノイドカバー	SOLENOID COVER	
13	060400516	1	バインド4X5	SCREW BIND M4X5	
14	062501016	2	ナベコ5X10	SCREW PAN M5X10	
15	148546001	1	プランジャピン	PLUNGER PIN	
16	SA2682101	1	イトハライリンククミ	THREAD WIPER LINK ASSY	
17	SA2683001	1	ソレノイドリンク	SOLENOID LINK	
18	S07549101	2	イトハライリンクC	THREAD WIPER LINK, C	
19	S07550001	1	リンクジク	LINK STUD	
20	SA2504001	1	セツカラー	SET SCREW COLLAR	
21	012500536	2	アナヒラ5X5	SET SCREW SOCKET (FT) M5X5	
22	SA8745001	1	ストツパ	STOPPER	
23	062500816	2	ナベコ5X8	SCREW PAN M5X8	
24	025050236	2	ヒラザガネチユウ5	WASHER PLAIN M 5	
25	S07552101	2	イトハライウケ	THREAD WIPER SUPPORT	
26	062661212	2	ナベコ3.18-40X12	SCREW PAN SM3.18-40X12	
27	SA2684001	1	イトハライバネ	THREAD WIPER SPRING	
28	062501016	2	ナベコ5X10	SCREW PAN M5X10	
29	S07553001	2	イトハライ	THREAD WIPER	
30	S07424001	2	トメネジ3.18	SET SCREW, W/SOCKET SM3.18X4	

T1 . コントロールボックス、モータ関係 / Control box and motor mechanism

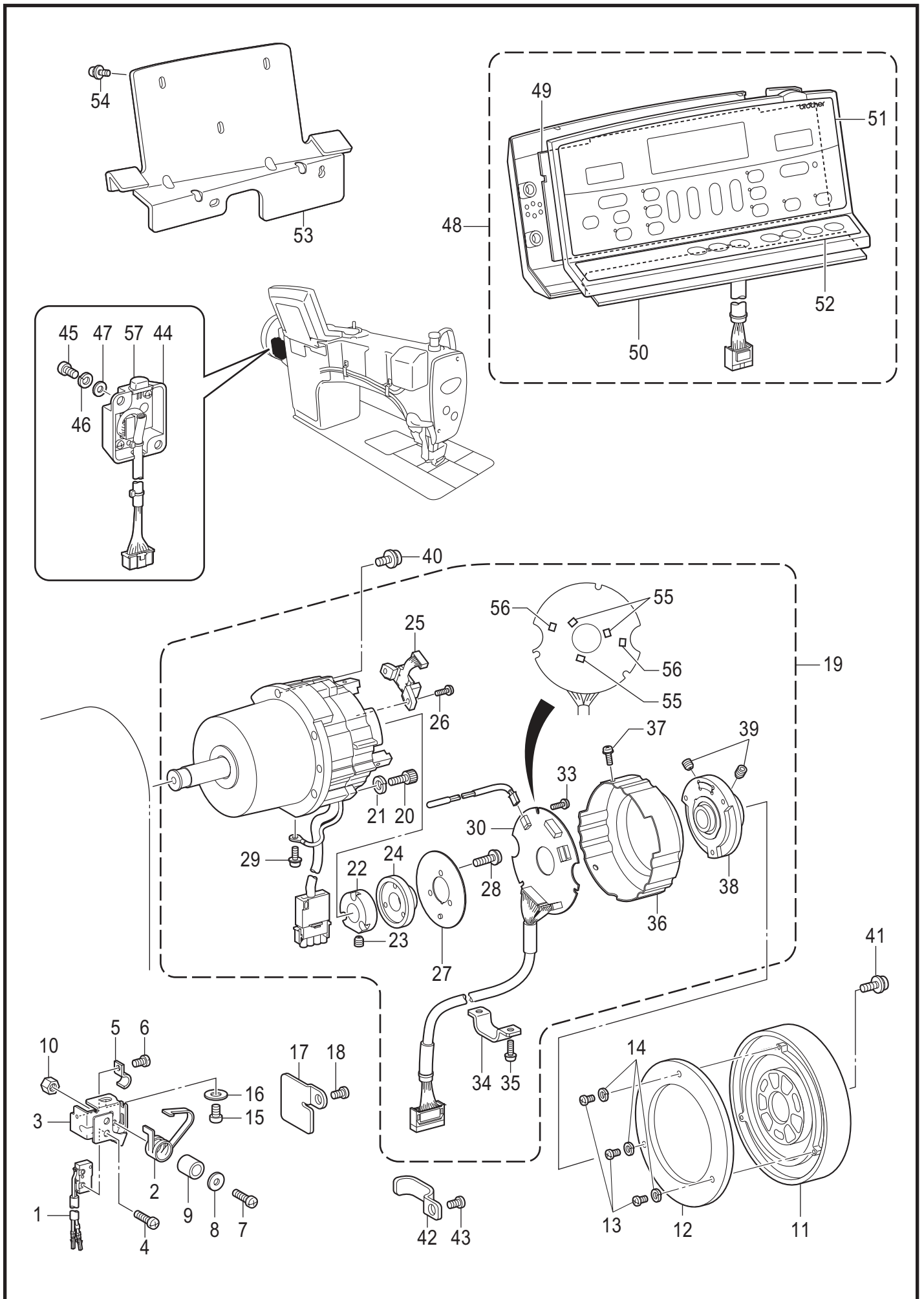

T1 . コントロールボックス、モータ関係 / Control box and motor mechanism

REF.NO	CODE	Q'TY	品名	NAME OF PARTS	RM
1	SA1385001	1	マイクロスイッチクミ	MICRO SWITCH ASSY	
2	S38744101	1	スイッチイタバネ	SWITCH PLATE SPRING	
3	SA2686001	1	スイッチダイ	SWITCH BASE	
4	062020806	2	ナベコ2X8	SCREW PAN M2X8	
5	140647101	1	コードオサエ	CORD HOLDER	
6	062400616	1	ナベコ4X6	SCREW PAN M4X6	
7	062401216	1	ナベコ4X12	SCREW PAN M4X12	
8	026040236	1	ヒラザガネミガキ4	WASHER PLAIN M 4	
9	154514001	1	スペーサー	SPACER	
10	021400106	1	1シユナツト4	NUT 1 M4	
11	SA4040001	1	プーリCDD	PULLEY, CDD	
12	SA3175001	1	ガードプレート	GUARD PLATE	
13	062300616	3	ナベコ3X6	SCREW PAN M3X6	
14	028030246	3	バネザガネ2-3	WASHER SPRING 2-3	
15	062060812	1	ナベコ6X8	SCREW PAN M6X8	
16	025060136	1	ヒラザガネシヨウ6	WASHER PLAIN S 6	
17	SA2712001	1	コードオサエ	CORD HOLDER	
18	062500816	1	ナベコ5X8	SCREW PAN M5X8	
19	J80990001	1	モータクミCDD-HT	MOTOR ASSY CDD-HT	
20	018501632	3	アナボルト5X16	BOLT SOCKET M5X16	
21	028050247	3	バネザガネ2-5	WASHER SPRING 2-5	
22	J03955001	1	ドラムコテイCDD	DRUM CDD	
23	014400632	2	アナクボミ4X6	SET SCREW SOCKET (CP) M4X6	
24	J03956001	1	ジシヤク180P36	MAGNET 180P36	
25	J03957001	1	MRセンサクミ180P	MR SENSOR ASSY 180P	
26	0A4301006	2	+ナベザクミ3X10DA	SCREW PAN (S/P WASHER) M3X10	
27	J03958001	1	シヤヘイイタCDD	SHIELD PLATE CDD	
28	0A4261006	3	+ナベザクミ26X10DA	SCREW PAN (S/P WASHE) M2.6X10	
29	0A4401005	1	+ナベザクミ4X10DA	SCREW, PAN (S/P WASHE) M4X10	
30	J80971001	1	CDD-ENCキバンクミ	PCB ASSY, CDD-ENC	
33	0A5300606	3	+ナベザクミ3X6DB	SCREW PAN (S/P WASHER) M3X6	
34	J04230001	1	コードオサエCDD-HT	CORD HOLDER CDD-HT	
35	0A4401006	2	+ナベザクミ4X10DA	SCREW PAN (S/P WASHE) M4X10	
36	J04296001	1	エンコ-ダカバ-CDD#2	ENCODER COVER CDD #2	
37	0A4300806	3	+ナベザクミ3X8DA	SCREW PAN (S/P WASHER) M3X8	
38	J03964001	1	プーリトリツケタイクミCDD	PULLEY HOLDER ASSY CDD	
39	014500632	2	アナクボミ5X6	SET SCREW SOCKET (CP) M5X6	
40	SA2354001	5	+ナベセットネジ5X18	SCREW PAN M5X18	
41	SA3025001	3	ナベザクミ4X10DA	SCREW PAN (S/P WASHER) M4X10	
42	SA2687001	1	コードオサエ	CORD HOLDER	
43	062500816	1	ナベコ5X8	SCREW PAN M5X8	
44	SA8530001	1	トウブケンシユツユニット	HEAD DETECTOR UNIT	
45	062500816	2	ナベコ5X8	SCREW PAN M5X8	
46	028050246	2	バネザガネ2-5	WASHER SPRING 2-5	
47	026050136	2	ヒラザガネコガタ5	WASHER PLAIN S 5	
57	J04392001	1	LEDカバー	LED COVER	
48	BMP2060-0000000-CG40	1	< 中国向 > G40パネル	<For China Only> G-40-PANEL-CHINA	
48	BMP2060-0000000-0G40	1	< 中国-欧州以外向 > G40パネル	<Exept for China and Europe> G-40-PANEL	
48	BMP2060-0000000-EG40	1	< 欧州向 > G40パネル	<For Europe Only> G-40-PANEL-EU	
49	J80973001	1	G40パネルキバンクミ	G40 PANEL PCB ASSY	
50	J80974001	1	G40サブキバンクミ	G40 SUB PCB ASSY	
51	J03975001	1	G40パネルカザリイタ1	G40 PANEL SEAT 1	
52	J03976001	1	G40パネルカザリイタ2	G40 PANEL SEAT 2	
53	J04195001	1	パネルトリツケイタ#2	PANEL SETTING PLATE#2	
54	J04273001	3	ナベザクミ4X10DB	SCREW PAN (S/P WASHER) M4X10	
55	J03983001	3	ホールICE W-400	HALL ELEMENT: ICE-400	
56	J03984001	2	ホールICE W-450	HALL ELEMENT: ICE-450	

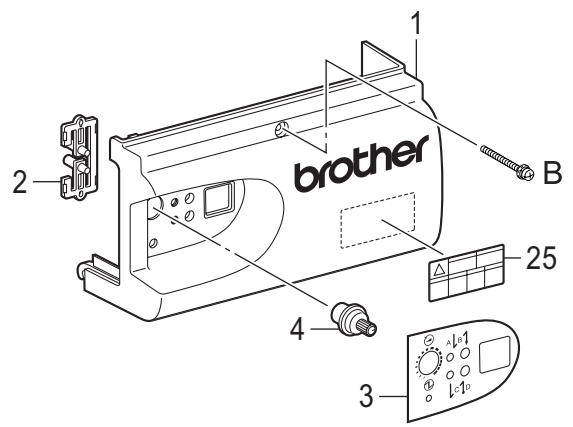
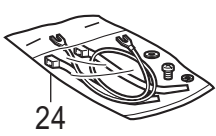
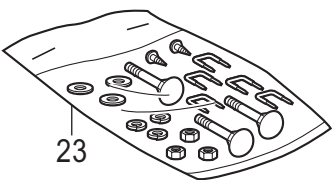
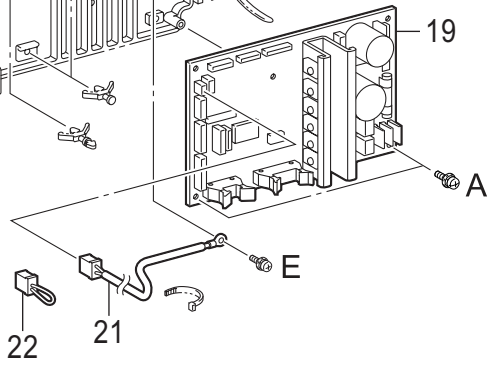
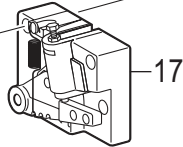
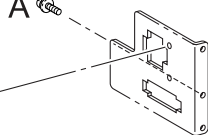
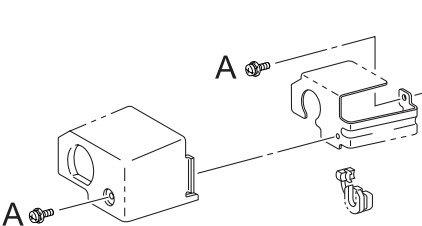
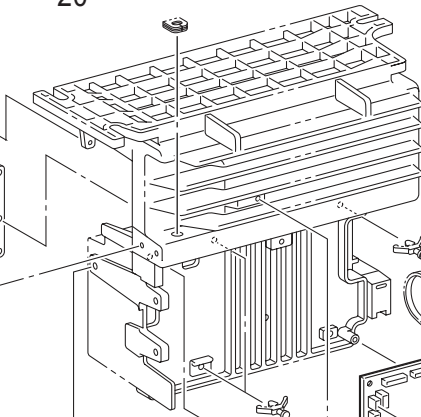
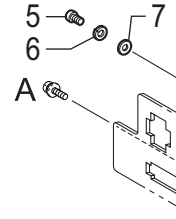
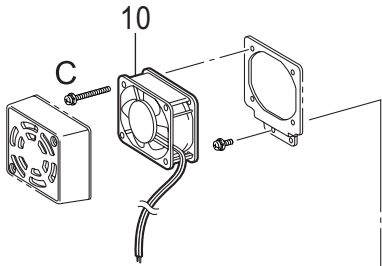
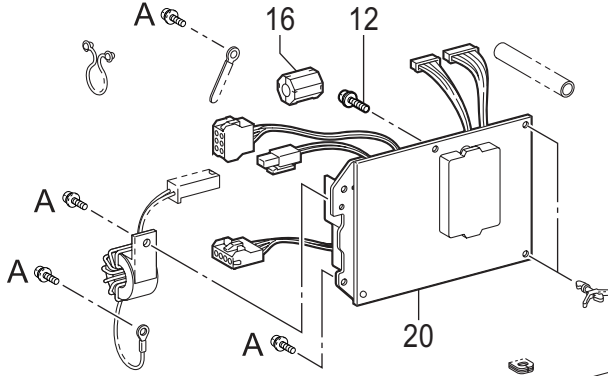
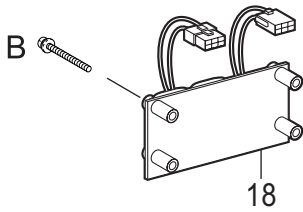
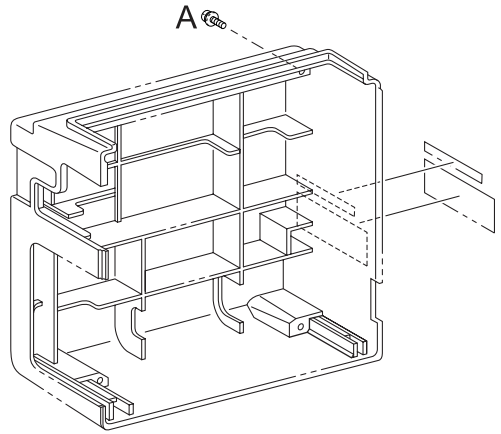
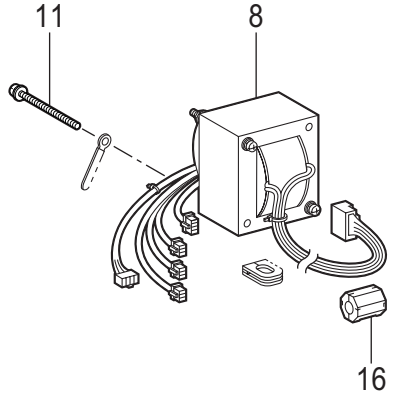
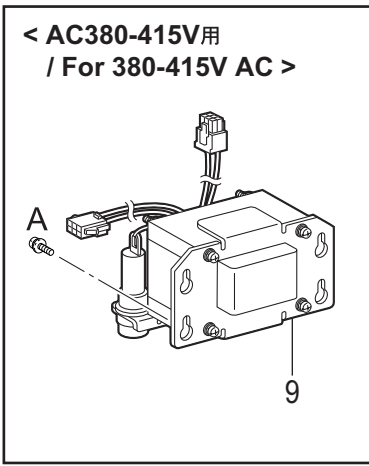

ねじの種類 / Type of screw

A	4X10 DA
B	4X25 DA
C	4X35 DA
D	5X14 DB
E	3X8 DA

T2 . コントロールボックス関係 / Control box mechanism

REF.NO	CODE	Q'TY	品名	NAME OF PARTS	RM
1	J04393001	1	CDDマエフタGO	FRONT BOX COVER CDD GO	
2	J04438001	1	キートップCDD-GO	KEY TOP	
3	J04440001	1	PカザリイタGO	PANEL SHEET CDD GO	
4	J04436001	1	VツマミLCA	SPEED ADJUST KNOB	
5	062400863	1	ナベコ4X8	SCREW PAN M4X8	
6	028040245	1	バネザガネ2-4	WASHER SPRING 2-4	
7	025040173	1	ヒラザガネシヨウ4	WASHER PLAIN S 4	
			<AC100 - 110V用>	<For 100 - 110V AC>	
8	J04097001	1	トランスCDD-100V	TRANSFORMER CDD-100V	
			<AC200 - 240V用>	<For 200 - 240V AC>	
8	J04098001	1	トランスCDD-200V	TRANSFORMER CDD-200V	
			<AC380 - 415V用>	<For 380 - 415V AC>	
8	J04098001	1	トランスCDD-200V	TRANSFORMER CDD-200V	
9	J04593001	1	トランス400V-SP	TRANSFORMER 400V-SP	
10	J04167001	1	DCファンCDDクミ#2	DC FAN ASSY, CDD #2	
11	J01411001	2	+ナベザクミ4X50DA	SCREW PAN (S/P WASHER) M4X50	
12	J00494001	2	+ナベセット4X14DA	SCREW PAN (S/P WASHER) M4X14	
13	J03739001	1	CRコテイイタ	SPRING PLATE, CR	
15	J04100001	1	セメントR40/220クミ#6	CEMENT RESISTOR ASSY 40/220 #6	
			<欧州向用>	<For Europe>	
16	J04468001	2	コアESD-SR-120	CORE: SD-SR-120	
			<前一段, 後一段タイプ>	<Type forward 1 step, backward 1 step>	
17	J80967001	1	フミコユニットCDD-コクホ	TREADLE UNIT ASSY CDD G	
			<前二段, 後二段タイプ>	<Type forward 2 step, backward 2 step>	
17	J80968001	1	フミコユニットCDD-ユホ	TREADLE UNIT ASSY CDD H	
			<欧州向用>	<For Europe>	
18	J80970001	1	CEフィルタキバンクミ	CE FILTER PCB ASSY	
19	J81008001	1	SキバンCDDクミ#GO-F	CONTROL PCB ASSY CDD #GO-F	
			<AC100 - 240V用>	<For 100 - 240V AC>	
22	J04168001	1	ショートコネクタ	SHORT CONNECTOR	
			<AC380 - 415V用>	<For 380 - 415V AC>	
21	J04169001	1	CDDサーミスタ#2	THERMISTOR, CDD #2	
			<AC100 - 110V用>	<For 100 - 110V AC>	
20	J80965001	1	DキバンCDD1-110Vクミ	POWER PCB ASSY, CDD 1-110V	
			<AC220 - 415V用>	<For 220 - 415V AC>	
20	J80966101	1	DキバンCDD1-230Vクミ	POWER PCB ASSY CDD 1-230V	
23	J04210001	1	カクネ8X65クミ	BOLT ASSY, SQUARE M8X65	
24	J04243001	1	アースコードネジタイクミ	EARTH CORD SCREW TIE ASSY	
25	J04115001	1	ラベルカンデン6カコク	LABEL, ELEC. SHOCK 6 LANG	

U . 逆転スイッチ関係 / Quick reverse switch mechanism

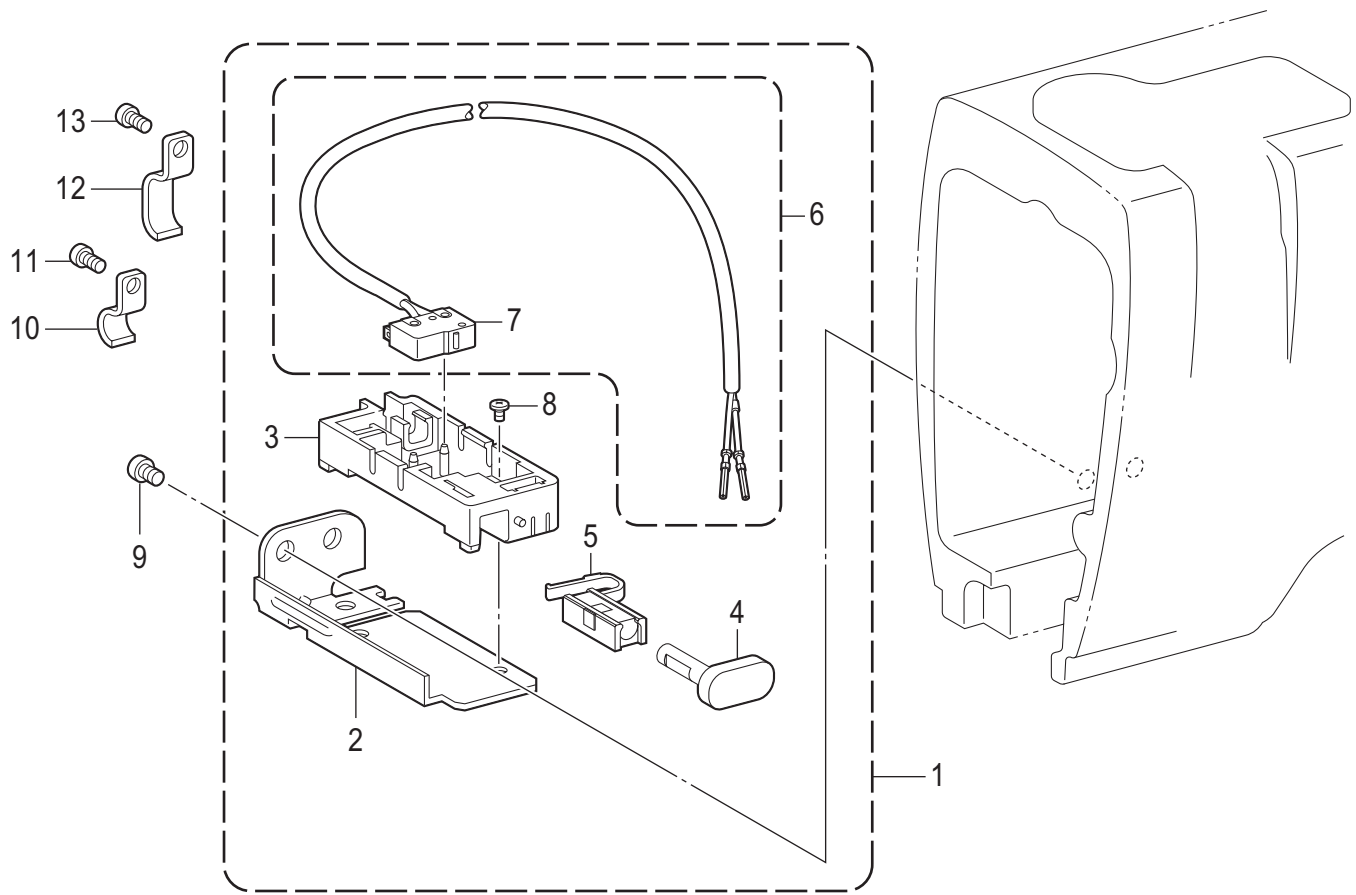

U . 逆転スイッチ関係 / Quick reverse switch mechanism

REF.NO	CODE	Q'TY	品名	NAME OF PARTS	RM
1	SA2688201	1	Rアクチュエータクミ	REVERSE ACTUATOR ASSY	
2	SA2270001	1	Rスイッチササエ	REVERSE SWITCH BRACKET	
3	S34281000	1	Rスイッチダイ	REVERSE SWITCH BRACKET	
4	S32904101	1	アクチュエータ	ACTUATOR	
5	SA4099001	1	Rスイッチバネ	REVERSE SWITCH SPRING	
6	SA1390001	1	Rスイッチクミ	R-SWITCH ASSY	
7	S32907000	1	マイクロスイッチ	MICRO SWITCH	
8	060300606	1	バインド3X6	SCREW BIND M3X6	
9	062500616	2	ナベコ5X6	SCREW PAN M5X6	
10	SA2689101	1	コードオサエ	CORD HOLDER	
11	062500616	1	ナベコ5X6	SCREW PAN M5X6	
12	SA1388101	3	コードオサエ	CORD HOLDER	
13	062500616	1	ナベコ5X6	SCREW PAN M5X6	

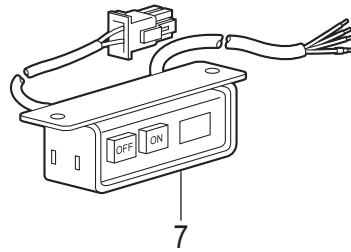
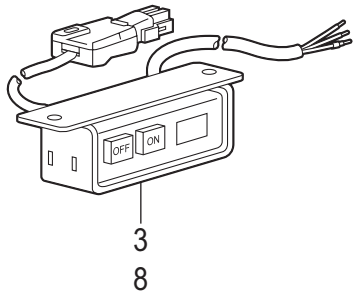
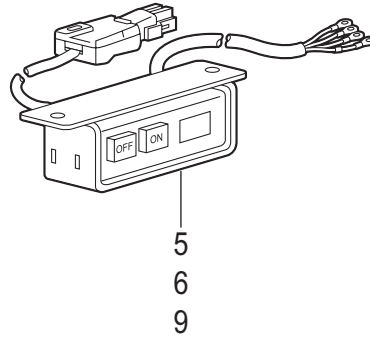
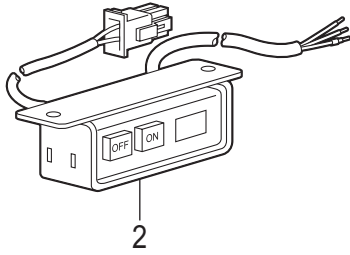
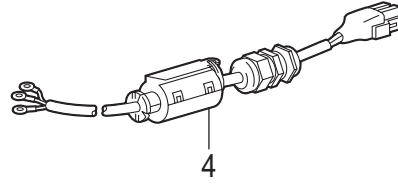
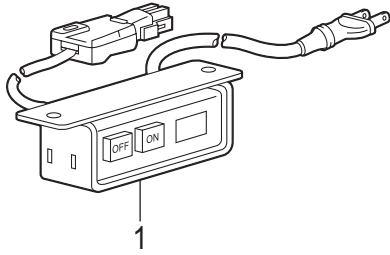

V. 電装品関係 / Power supply equipment mechanism

REF.NO	CODE	Q'TY	品名	NAME OF PARTS	RM
1	J04086001	1	<单相 100V AC用> <日本向用> デンSWクミ1-100V#6	<For Single phase 100V AC> < For Japan > POWER SWITCH ASSY 1-100V #6	
2	J04469001	1	<单相 110V AC用> <北米・メキシコ向用> デンSWクミ1-110V#8	<For Single phase 110V AC> < For USA, Canada & Mexico > POWER SWITCH ASSY 1-110V #8	
3	J04093001	1	<单相 220V AC用> <一般アジア・北アフリカ向用> デンSWクミ1-240V#6	<For Single phase 220V AC> < For General of Asia & North africa > POWER SWITCH ASSY 1-240V #6	
4	J04134001	1	<单相 230V AC CE 用> 電源スイッチ無 <欧州向用> デンPGクミ1-240V#6	<For Single phase 230V AC CE> Power SW-less < For Europe > POWER PLUG ASSY 1-240V #6	
5	J04096001	1	<三相 380V AC 用> <一般アジア・北アフリカ向用> デンSWクミ3-400V#6	<For Three phase 380V AC> < For General of Asia & North africa > POWER SWITCH ASSY 3-400V #6	
6	J04149001	1	<三相 200V AC 用> <日本向用> デンSWクミ3-200V#6	<For Three phase 200V AC> < For Japan > POWER SWITCH ASSY 3-200V #6	
7	J04470001	1	<三相 220V AC 用> <北米・メキシコ向用> デンSWクミ3-240V#8	<For Three phase 220V AC> < For USA, Canada & Mexico > POWER SWITCH ASSY 3-240V #8	
8	J04251001	1	<单相 220V AC用> <中国向用> デンSWクミ1-240V#CCC	<For Single phase 220V AC> < For China > POWER SWITCH ASSY 1-240V #CCC	
9	J04255001	1	<三相 380V AC 用> <中国向用> デンSWクミ3-400V#CCC	<For Three phase 380V AC> < For China > POWER SWITCH ASSY 3-400V #CCC	

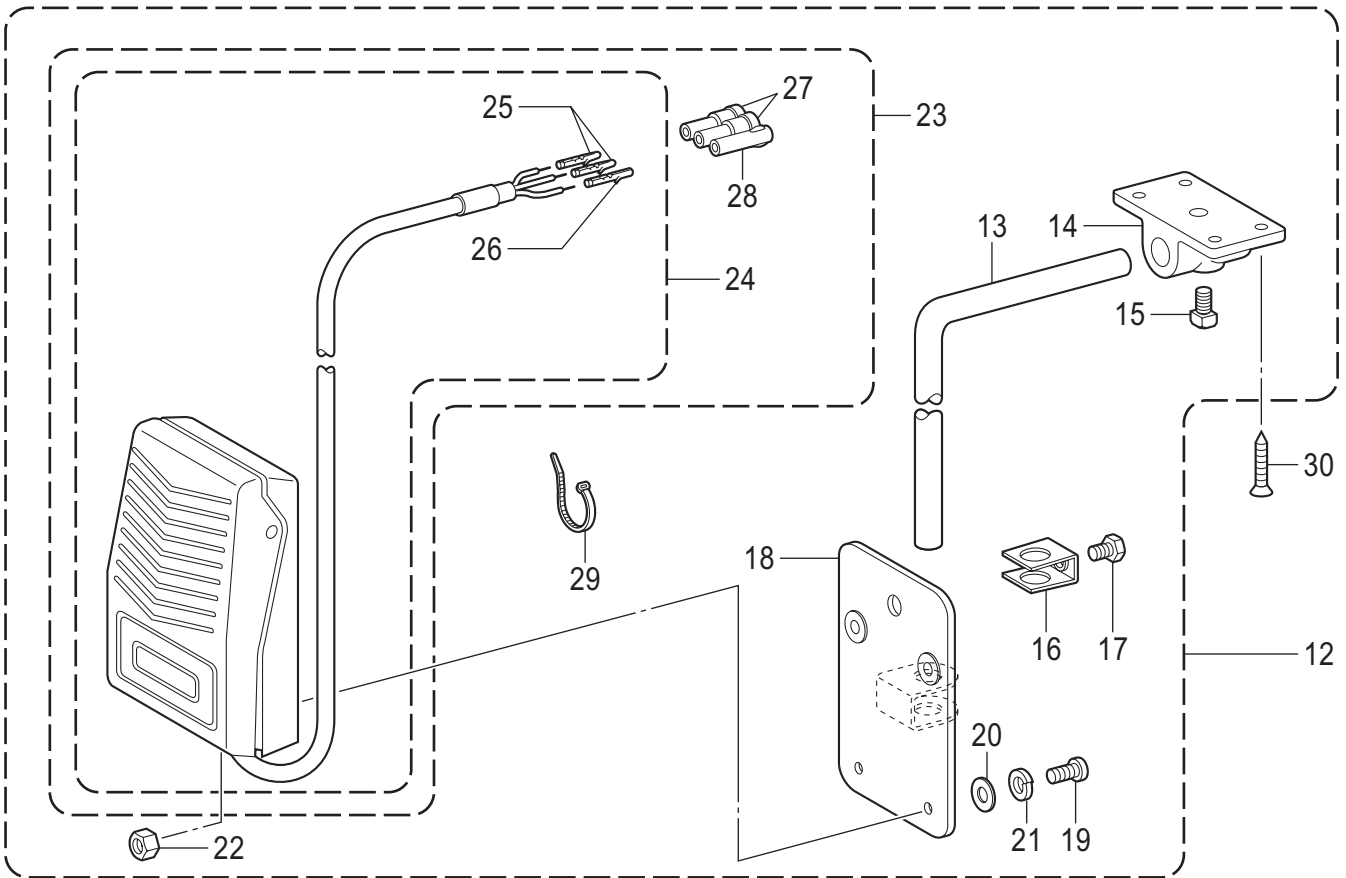
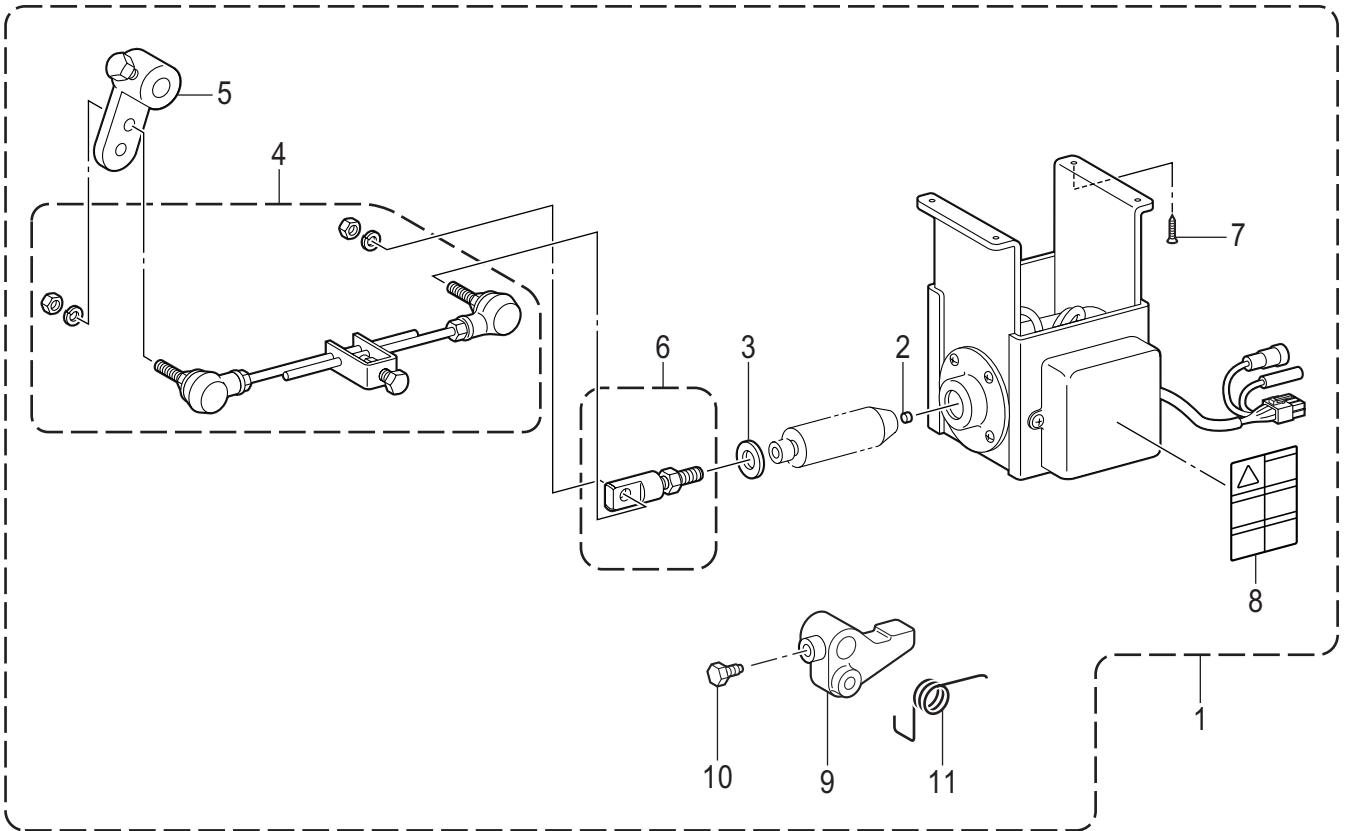

W . 電磁押え上げセット関係(オプション部品)/ Presser foot lifting solenoid set mechanism (Option parts)

REF.NO	CODE	Q'TY	品名	NAME OF PARTS	RM
1	SA2707001	1	デンジオサエアゲセットD2	P-FOOT LIFTER SOLENOID SET, D2	
2	S54025001	1	クッション	CUSHION	
3	S54024001	1	クッションリング	CUSHION RING	
4	S42198051	1	オサエアゲロッドクミ	PRESSER FOOT LIFTER ROD ASSY	
5	S42199051	1	オサエアゲレバークミ	P-FOOT LIFTER LEVER ASSY	
6	S41955051	1	ロッドツギテクミ	ROD JOINT ASSY	
7	S42200051	4	モクネジ	WOOD SCREW	
8	S38351001	1	コウオンラベル	LABEL, HIGH TEMP	
9	S10550001	1	オサエアゲリンク	PRESSER BAR LIFTER LINK	
10	146367001	1	ボルト5.95	BOLT, SM5.95	
11	S07729001	1	ネジリバネ	SPRING, TWIST	
12	S07045009	1	ヒザスイツチクミ	KNEE LIFTER SWITCH ASSY	
13	142026003	1	ヒザスイツチタテジク	KNEE SWITCH SHAFT	
14	142027001	1	ヒザスイツチタテジクウケ	BRACKET	
15	100463001	1	4カクボルト7.94	BOLT, SQUARE SM7.94	
16	114967001	1	ヒザアテストツパ	KNEE LIFTER PLATE STOPPER	
17	110087001	1	ボルト5.95	BOLT, SM5.95-28X8	
18	S07027001	1	ヒザスイツチトリツケイタ	K-LIFTER SWITCH SETTING PLATE	
19	062401006	4	ナベコ4X10	SCREW PAN M4X10	
20	025040233	4	ヒラザガネチユウ4	WASHER, PLAIN M 4	
21	028040243	4	バネザガネ2-4	WASHER, SPRING 2-4	
22	021400164	4	1シュナツト4	NUT, 1 M4	
23	S07030009	1	スイッチコードクミ	SWITCH & HARNESS ASSY	
24	S07031009	1	フットスイッチクミ	FOOT SWITCH ASSY	
25	143549000	2	ピンターミナルオス	TERMINAL PIN, MALE	
26	143548000	1	ピンターミナルメス	TERMINAL PIN, FEMALE	
27	146046000	2	ナイロンコネクタ	NYLON CONNECTOR	
28	146194000	1	ナイロンコネクタ	NYLON CONNECTOR	
29	149799000	1	タイラツプS	BEAD BAND, S	
30	034422503	4	+2サラモク41X25	WOOD SCREW, FLAT 2 M4.1X25	

Z1 . 付属品関係 / Accessories

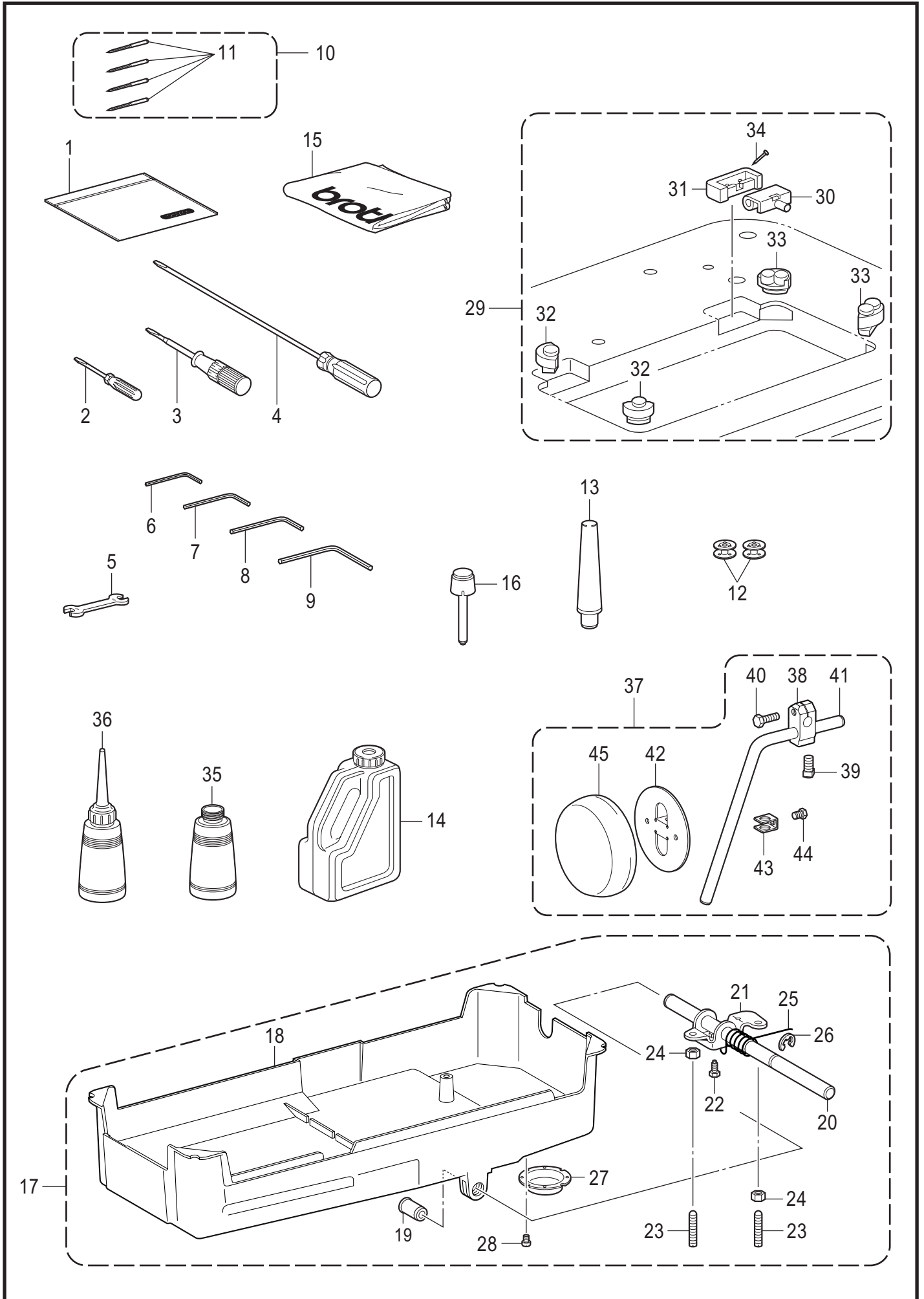

Z1 . 付属品関係 / Accessories

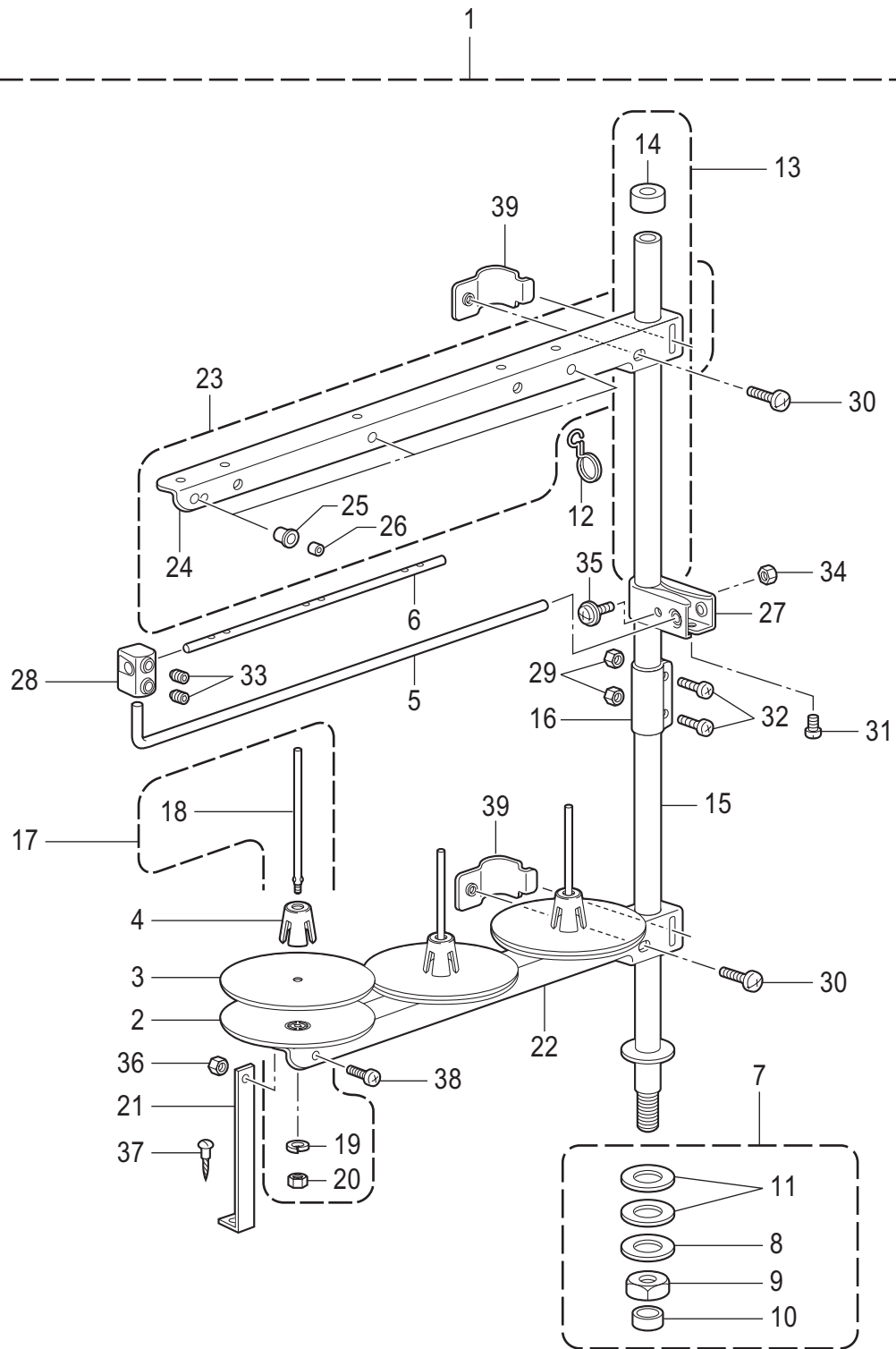

REF.NO	CODE	Q'TY	品名	NAME OF PARTS	RM
1	122991001	1	フゾクヒンポリフクロ	ACCESSORY BAG	
2	142443001	1	ネジマワシ1.9X52	SCREW-DRIVER, 1.9X52	
3	118837001	1	ネジマワシ3.4X70	SCREW-DRIVER, 3.4X70	
4	S17774001	1	ネジマワシ4.7X250	SCREW-DRIVER, 4.7X250	
5	100887001	1	スパナ8X9	WRENCH, 8X9	
6	142002001	1	6カクボウスパナ2	HEXAGONAL WRENCH, 2	
7	154125001	1	6カクボウスパナ2.5	HEXAGONAL WRENCH, 2.5	
8	142721001	1	6カクボウスパナ3	HEXAGONAL WRENCH, 3	
9	149570001	1	6カクボウスパナ5	HEXAGONAL WRENCH, 5	
			<-403用>	<For -403>	
10	SA1752014	1	107415ハリ4コイリクミ	NEEDLE 4PIECE ASSY, 107415	
11	107415014	4	ミシンハリDPX5	NEEDLE, DPX5	
			<-405用>	<For -405>	
10	SA1752022	1	107415ハリ4コイリクミ	NEEDLE 4PIECE ASSY, 107415	
11	107415022	4	ミシンハリDPX5	NEEDLE, DPX5	
12	S01928151	2	ボビン	BOBBIN	
13	100477009	1	マクラ	HEAD REST	
14	S55663001	1	オイルタンククミ	OIL TANK ASSY	
15	144226001	1	トウブカバー	HEAD COVER	
16	145573000	1	ヒザアゲオシボウ	KNEE LIFTER COMPLYING BAR	
17	SA2691101	1	アブラウケクミ	OIL PAN ASSY	
18	SA2692101	1	アブラウケ	OIL PAN	
19	149578000	2	ヨコジクブツシュ	BUSH	
20	SA2582001	1	ヒザアゲヨコジク	KNEE LIFTER SHAFT	
21	SA2590001	1	ヒザアゲ	KNEE LIFTER	
22	S25344001	1	ボルト6	BOLT M6	
23	S25475101	2	トメネジ6	SET SCREW, M6X19	
24	021060306	2	3シユナツト6	NUT 3 M6	
25	S15889001	1	ヒザアゲネジリバネ	TWIST SPRING	
26	146293001	1	トメワE10	RETAINING RING, E10	
27	153230101	1	オイルニガシグチ	DRAIN	
28	S23418002	2	シメネジ4X5	SCREW, M4X5	
29	SA1969001	1	ラバ-ヒンジクミ	RUBBER HINGE ASSY	
30	143882001	2	トウブヒンジ	HEAD HINGE	
31	143910009	2	トウブヒンジウケゴム	RUBBER CUSHION	
32	SA1962001	2	トウブシキゴム	HEAD CUSHION	
33	SA1963001	2	トウブシキゴム	HEAD CUSHION	
34	109714000	4	クギ	NAIL	
35	114486002	1	ポリオイラータイ	OILER	
36	114483002	1	ポリオイラークミ	OILER ASSY	
37	S38300001	1	ヒザアテクミ	KNEE LIFTER ASSY	
38	146039121	1	ヒザアテツギテ	KNEE LIFTER BRACKET	
39	100463021	1	4カクボルト7.94	BOLT, SQUARE SM7.94	
40	S35820021	1	ボルト5.95X20	BOLT, SM5.95X20	
41	S38278001	1	ヒザアゲタテジク	KNEE LIFTER BAR	
42	S34756021	1	ヒザアテ	KNEE LIFTER PLATE	
43	114967021	1	ヒザアテストップ	KNEE LIFTER PLATE STOPPER	
44	110087021	1	ボルト5.95	BOLT, SM5.95-28X8	
45	S31885001	1	ヒザアテカバー	KNEE LIFTER PLATE COVER	



Z2. 付属品関係 / Accessories

REF.NO	CODE	Q'TY	品名	NAME OF PARTS	RM
1	S07558409	1	イトタテダイクミ3DRTHF	COTTON STAND ASSY 3DRTHF	
2	S51283001	3	ウケザラ	SPOOL STAND BASE	
3	150182000	3	スプールマット	SPOOL MAT	
4	S51282101	3	スプールクッション	SPOOL CUSHION	
5	S04109001	1	イトアンナイササエボウ	THREAD GUIDE SUPPORT BAR	
6	142997001	1	イトアンナイ3	THREAD GUIDE, 3	
7	SA6627001	1	パイプDネジセットB	PIPE D SCREW SET B	
8	150206002	1	ヒラザガネ16	WASHER, PLAIN 16	
9	SA6629001	1	6カクナツトM16	NUT M16	
10	150174000	1	コラムキャップ	COLUMN CAP	
11	S01005000	2	イトタテゴム	RUBBER WASHER	
12	S02747101	1	イトカケバネ	SPRING	
13	S40639001	1	コラムパイプキャップツキ	COLUMN PIPE W/CAP	
14	150174000	1	コラムキャップ	COLUMN CAP	
15	156112003	1	コラムパイプD	COLUMN PIPE D	
16	SA6606001	1	コラムジョイント	COLUMN JOINT	
17	S21798001	3	スプールネジセット	SPOOL & SCREW SET	
18	150179002	3	スプールジクB	SPOOL SHAFT B	
19	028050244	3	バネザガネ2-5	WASHER SPRING 2-5	
20	021500104	3	1シュナツト5	NUT 1 M5	
21	150188009	1	スプールホルダ-ササエA	SPOOL HOLDER SUPPORT, A	
22	SA6610001	1	スプールホルダ-3	SPOOL HOLDER 3	
23	SA6611001	1	スレツドハンガ-クミ3	THREAD HANGER ASSY 3	
24	SA6610001	1	スプールホルダ-3	SPOOL HOLDER 3	
25	150183000	3	イトカケハンガ-ダイ	THREAD HANGER BASE	
26	142990001	3	スレツドブツシュ	THREAD BUSH	
27	SA6615001	1	イトアンナイホルダ-	THREAD GUIDE HOLDER	
28	138843001	1	ササエボウツギテ	JOINT	
29	021500104	2	1シュナツト5	NUT 1 M5	
30	062061604	2	ナベコ6X16	SCREW PAN M6X16	
31	S37037001	1	ナベコヒラザ5X32	SCREW PAN (S/P WASHER) M5X32	
32	062501404	2	ナベコ5X14	SCREW PAN M5X14	
33	014060632	2	アナクボミ6X6	SET SCREW SOCKET (CP) M6X6	
34	021500104	1	1シュナツト5	NUT 1 M5	
35	S37037001	1	ナベコヒラザ5X32	SCREW PAN (S/P WASHER) M5X32	
36	021500104	1	1シュナツト5	NUT 1 M5	
37	031452204	1	マルモク45X22	WOOD SCREW ROUND M4.5X22	
38	062501004	1	ナベコ5X10	SCREW PAN M5X10	
39	SA6609001	2	スプールホルダ-ササエ	SPOOL HOLDER SUPPORTER	

Wa. 警告ラベル / Warning labels

警告ラベル / Warning labels	品名 / Name of parts	Size(mm)	Code
	<p>ラベル感電6ヶ国 Label, elec. shock 6 lang</p>	50 X 118	J04115-001
	<p>ラベル注意・和英 Label, caution Jpn / Eng</p>	64 X 40	SA2040-001
	<p>ラベル注意・中英 Label, caution Chn / Eng</p>	64 X 40	SA2041-001
	<p>アースマーク Label, grounding</p>	φ 12	S37060-001
	<p>高温ラベル Label, high temp</p>	72 X 59	S38351-001

T-8452B-Wa

Sp. 仕様別部品一覧表 / Different parts list

■ かま / Rotary hooks

部品コードは、かまが箱に入った組コードです。

The following parts codes are assigned for the rotary hooks in the boxes.

● 標準 / Normal

	全仕様 / All type
かま箱組 / Rotary hook assy	SA1683-111
調子バネ / Tension spring	151043-001

Ga. ゲージ部品一覧表 / Gauge parts list

標準品 / For Normal

- * 最大針幅 15.9mmまで出来ます。
- * 糸切り用固定刃(S07527-001)と取付ネジ(148539-101)は、針板には付けてありませんので、必要に応じて別途ご注文して下さい。
- * 2.4mm (3/32) のゲージを使用する場合は、DBX1 (#7-#18) の針を使用して下さい。
- * A maximum stitch width specification of 15.9mm is available.
- * The thread trimming fixed knife (part No. S07527-001) and the installation screw (part No. 148539-101) are not provided with the needle plate, so they must be ordered separately if required.
- * In case of using the gauge set 2.4mm (3/32), use needle size DBX1(#7-#18).

針幅 Needle gauge	針抱きセット Needle clamp set	針抱き組 Needle clamp assy	送り歯 Feed dog			押え組 Presser foot assy	
			針板 Needle plate	中厚物用 (-3,-5) For medium & heavy materials	中厚物用 (-3) For medium materials	厚物用 (-5) For heavy materials	中厚物用 (-3) For medium materials
2.4mm (3/32)	L: S15705-001 R: S15706-001	L: S15707-001 R: S15708-001	159398-001		148697-001		148679-001
3.2mm (1/8)	L: S15711-001 R: S15712-001	L: S15713-001 R: S15714-001	155722-001	148698-001	148699-001	S36550-001	S36552-001
4.0mm (5/32)	L: S15717-001 R: S15718-001	L: S15719-001 R: S15720-001	155724-001	148700-001	148701-001	148689-001	148683-001
4.8mm (3/16)	L: S15723-001 R: S15724-001	L: S15725-001 R: S15726-001	155851-001	148702-001	148703-001	S36554-001	S36556-001
5.6mm (7/32)	L: S15729-001 R: S15730-001	L: S15731-001 R: S15732-001	156816-001	156818-001		156819-001	
6.4mm (1/4)	L: S15735-001 R: S15736-001	L: S15737-001 R: S15738-001	155853-001	148704-001	148705-001	SA4051-101	SA4050-101
7.1mm (9/32)	L: S15741-001 R: S15742-001	L: S15743-001 R: S15744-001	S14530-001	S14532-001	S14533-001	S14534-001	S14536-001
7.9mm (5/16)	L: S15747-001 R: S15748-001	L: S15749-001 R: S15750-001	155855-001	149692-001	149691-001	149689-001	149687-001
9.5mm (3/8)	L: S15753-001 R: S15754-001	L: S15755-001 R: S15756-001	155857-001	149939-001	149938-001	149942-001	149940-001
11.1mm (7/16)	L: S15759-001 R: S15760-001	L: S15761-001 R: S15762-001	S01644-001	S01646-001		S01641-101	
12.7mm (1/2)	L: S15765-001 R: S15766-001	L: S15767-001 R: S15768-001	149677-001	149676-001	149675-001	149673-101	149671-101
15.9mm (5/8)	L: S15771-001 R: S15772-001	L: S15773-001 R: S15774-001	149954-001	149949-001	149948-001	149952-101	149950-101

空縫い用 / For sewing without material

- * 針板と送り歯と押え組が標準品と異なります。最大送りピッチは4mm以下でご使用下さい。
- * Needle plate, the feed dog and presser foot assembly is different from normal parts.
Use gauge components of for sewing without material which have a maximum feed pitch of 4mm or less.

針幅 Needle gauge	針抱きセット Needle clamp set	針抱き組 Needle clamp assy	針板 Needle plate	送り歯 Feed dog	押え組 Presser foot assy
4.8mm (3/16)	標準品 / Normal	標準品 / Normal	S20901-001	S20905-001	S20903-001
6.4mm (1/4)			S10507-001	S10509-101	S10510-001

Ga. ゲージ部品一覧表 / Gauge parts list

標準品 / For Normal

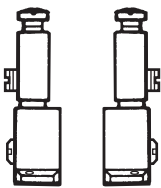
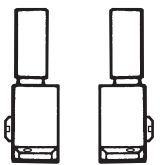
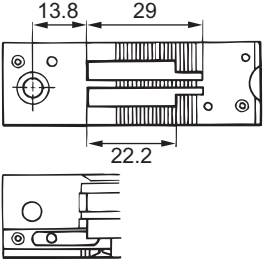
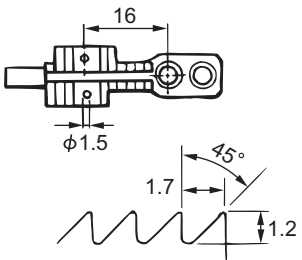
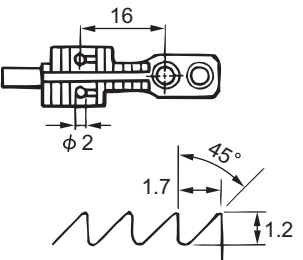
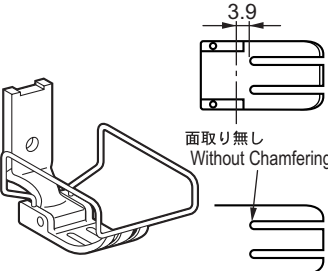
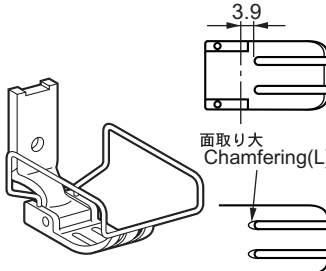
<p>針抱きセット Needle clamp set</p>	<p>針抱き組 Needle clamp assy</p>	<p>針板 Needle plate 中厚,厚物用(-3,-5) For medium & heavy materials</p>	
			
<p>送り歯 Feed dog</p>		<p>押え組 Presser foot assy</p>	
<p>中厚物用(-3) For medium materials</p>	<p>厚物用(-5) For heavy materials</p>	<p>中厚物用(-3) For medium materials</p>	<p>厚物用(-5) For heavy materials</p>
			

空縫い用 / For sewing without material

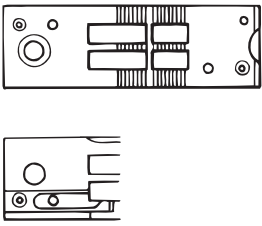
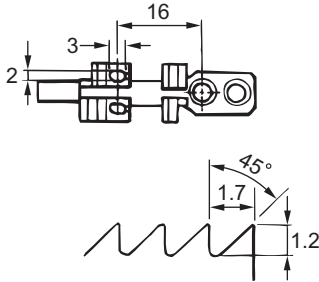
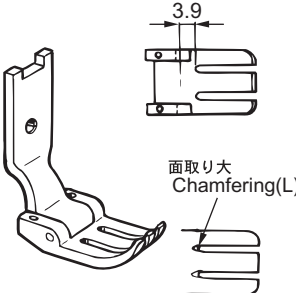
<p>針板 Needle plate</p>	<p>送り歯 Feed dog</p>	<p>押え組 Presser foot assy</p>
		

Ga. ゲージ部品一覧表 / Gauge parts list

厚物用 / For heavy materials

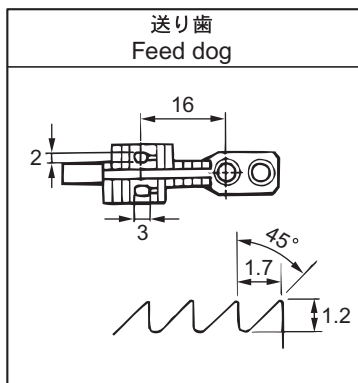

- * 送り歯が標準品と異なります。
- * The feed dog is different from normal parts.

針幅 Needle gauge	針抱きセット Needle clamp set	針抱き組 Needle clamp assy	針板 Needle plate	送り歯 Feed dog	押え組 Presser foot assy
4.8mm (3/16)	標準品 / Normal	標準品 / Normal	標準品 / Normal	S07905-001	標準品(-5) / Normal(-5)
6.4mm (1/4)				158756-001	

Ga. ゲージ部品一覧表 / Gauge parts list

下送り用 / For drop Feed

* 糸切り用固定刃(S07527-001)と取付ネジ(148539-101)は、針板には付けてありませんので、必要に応じて別途ご注文して下さい。

* 最大針幅 15.9mm まで出来ます。

* The thread trimming fixed knife (part No. S07527-001) and the installation screw (part No. 148539-101) are not provided with the needle plate, so they must be ordered separately if required.

* A maximum stitch width specification of 15.9mm is available.

針幅 Needle gauge	針抱きセット Needle clamp set	針抱き組 Needle clamp assy	針板 Needle plate	送り歯 Feed dog	押え組 Presser foot assy
3.2mm (1/8)	L: S15711-001 R: S15712-001	L: S15713-001 R: S15714-001	S07401-001	S07409-001	S38544-001
4.8mm (3/16)	L: S15723-001 R: S15724-001	L: S15725-001 R: S15726-001	S07403-001	S07410-001	S38542-001
6.4mm (1/4)	L: S15735-001 R: S15736-001	L: S15737-001 R: S15738-001	S07405-001	S07411-001	S38543-001
7.9mm (5/16)	L: S15747-001 R: S15748-001	L: S15749-001 R: S15750-001	S07676-001	S07680-001	S07682-001
9.5mm (3/8)	L: S15753-001 R: S15754-001	L: S15755-001 R: S15756-001	S13621-001	S13623-001	S13624-001
12.7mm (1/2)	L: S15765-001 R: S15766-001	L: S15767-001 R: S15768-001	S07678-001	S07681-001	S07684-101

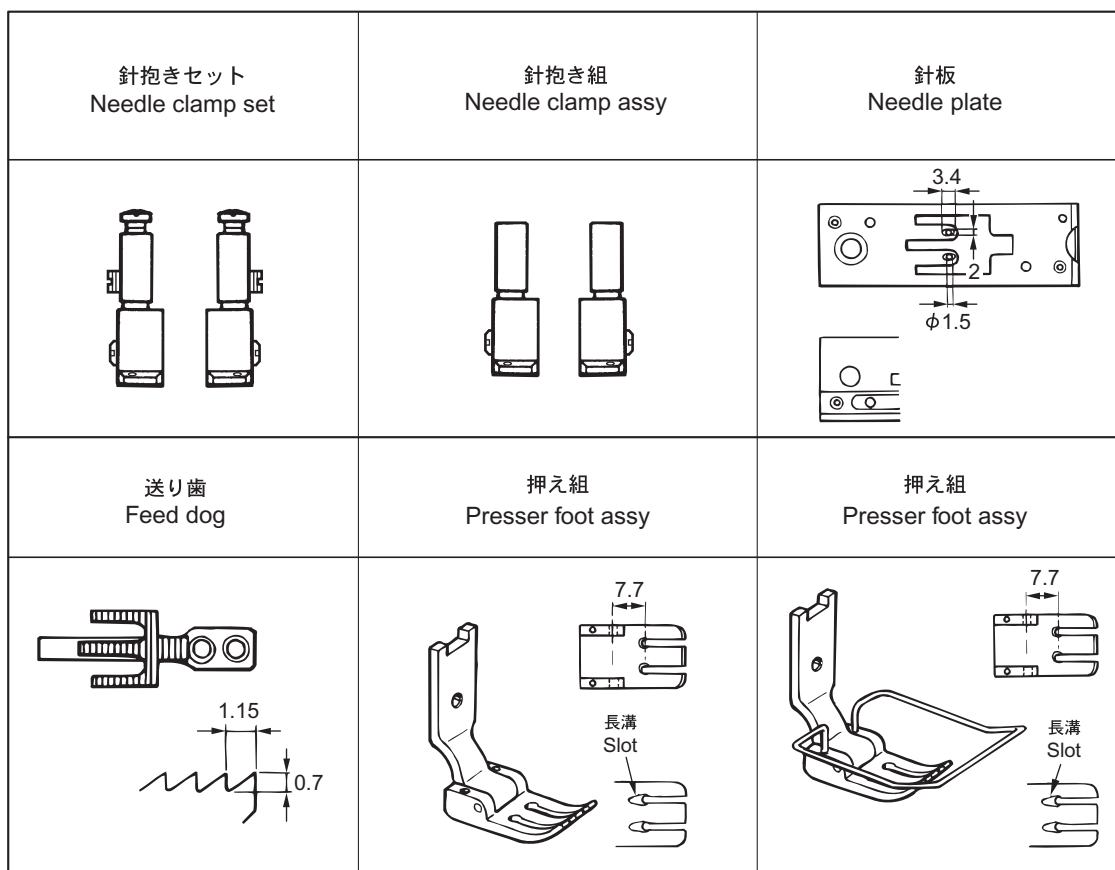

索引 / Index

CODE	REF.NO	Page	CODE	REF.NO	Page	CODE	REF.NO	Page	CODE	REF.NO	Page
SA5237101	C -41	8									
SA5293001	M -15	30									
SA5332001	C -61	8									
SA5333001	D -9	10									
SA5336001	D -3	10									
SA5588001	D -22	10									
SA6150101	H -11	18									
SA6166001	B -5	4									
SA6178001	M -6	30									
SA6294101	K1 -62	22									
	K1 -62	24									
SA6301001	K1 -22	22									
	K1 -22	24									
SA6307101	K1 -63	22									
	K1 -63	24									
SA6308001	H -31	18									
SA6378001	N -40	34									
SA6392001	Q -23	38									
SA6393001	Q -24	38									
SA6394001	Q -25	38									
SA6395001	Q -17	38									
SA6414001	M -62	32									
SA6415001	M -30	30									
SA6416001	M -61	32									
SA6417001	K1 -50	24									
SA6423001	M -29	30									
	M -60	30									
SA6424101	K1 -25	22									
SA6425101	K1 -45	24									
SA6462001	K1 -48	24									
SA6463001	K1 -49	24									
SA6468001	M -28	30									
SA6472001	M -42	30									
SA6473001	M -55	30									
SA6474001	K1 -7	22									
SA6475001	M -26	30									
SA6592001	F -41	14									
SA6606001	Z2 -16	56									
SA6609001	Z2 -39	56									
SA6610001	Z2 -22	56									
	Z2 -24	56									
SA6611001	Z2 -23	56									
SA6615001	Z2 -27	56									
SA6627001	Z2 -7	56									
SA6629001	Z2 -9	56									
SA7540001	M -25	30									
SA7548001	M -32	30									
SA7607001	E -5	12									
SA8364001	Q -61	38									
SA8365001	Q -62	38									
SA8530001	T1 -44	44									
SA8738001	C -1	6									
SA8740001	C -2	6									
SA8745001	S -22	42									
SA8749001	C -7	6									

brother[®]

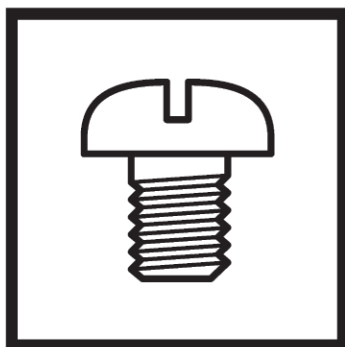

パーツブック
PARTS BOOK

ブラザー工業株式会社

BROTHER INDUSTRIES, LTD.

T-8452B
SA4425-101
2006.11.B (1)