

# T-8420B

パーツブック  
PARTS BOOK

---

2本針本縫ミシン  
TWIN NEEDLE LOCK STITCHER

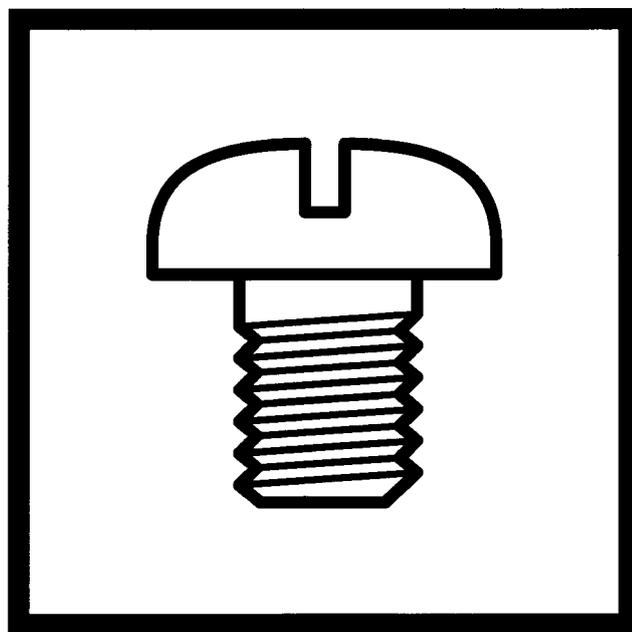

---

**brother**<sup>®</sup>

最新の部品情報は Parts Navigation でご覧いただけます。 <http://partsbook.brother.co.jp/partsnavi/jpn/index.html>  
The latest parts information, refer to the Parts Navigation. <http://partsbook.brother.co.jp/partsnavi/eng/index.html>

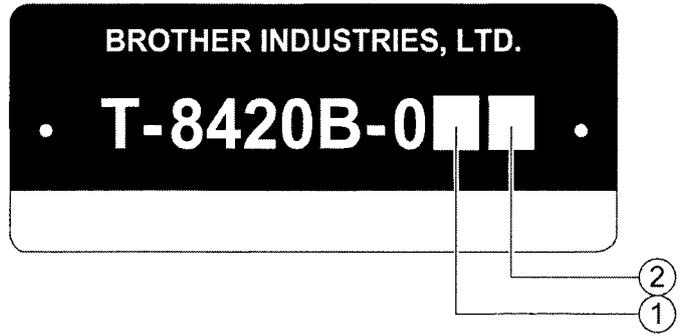

- ① — 0: 微量給油仕様 / Minimum lubrication type  
— 3: セミドライ仕様 / Semi dry type

- ② — 3: 中厚物 / Medium-weight materials  
— 5: 厚物 / Heavy-weight materials  
— F: ファンデーション / Foundation garments

# パーツブックご利用に際して

1. この本は、2004年 8月のデータに基づいて作成されたものです。
2. 部品は予告なしに設計変更される場合があります。
3. 組単位で補給する部品は、破線で示してあります。
4. 部品コード欄が \* となっている場合は、仕様別部品一覧表及びゲージ部品一覧表でお調べ下さい。  
(34から41ページ)

## 目 次

A. 主体関係 .....	1
B. 上軸関係 .....	3
C. 針棒揺動関係 .....	5
D. 押え関係 .....	7
E. 送り関係 .....	9
F. 送り軸関係 .....	11
G1. カマ関係 .....	13
G2. カマ関係 .....	17
H. ゲージ関係 .....	17
J. 下軸関係 .....	19
K. 電装品関係 .....	19
L. 給油潤滑関係 .....	21
M. 糸通し関係 .....	25
N. 糸巻関係 .....	27
Z1. 付属品関係 .....	29
Z2. 付属品関係 .....	31
Wa. 警告ラベル .....	33
Sp. 仕様別部品一覧 .....	34
Ga. ゲージ部品一覧 .....	35
索引 .....	42

## Notes for using this parts book

1. This book was prepared based on information available in August 2004.
2. Parts are subject to changes in design without prior notice.
3. Parts supplied as complete assemblies are circled by a dotted line .
4. If the symbol \* is found in the " Parts No." column, refer to the different parts lists, gauge parts list on page 34 - 41.

## CONTENTS

A. Machine body .....	1
B. Upper shaft mechanism .....	3
C. Needle bar rocking mechanism .....	5
D. Presser foot mechanism .....	7
E. Feed mechanism .....	9
F. Feed shaft mechanism .....	11
G1. Rotary hook mechanism .....	13
G2. Rotary hook mechanism .....	17
H. Gauge parts .....	17
J. Lower shaft mechanism .....	19
K. Power supply equipment mechanism .....	19
L. Lubrication .....	21
M. Threading mechanism .....	25
N. Bobbin winder mechanism .....	27
Z1. Accessories .....	29
Z2. Accessories .....	31
Wa. Warning labels .....	33
Sp. Different parts list .....	34
Ga. Gauge parts list .....	35
Index .....	42

A. 主体関係 / Machine body

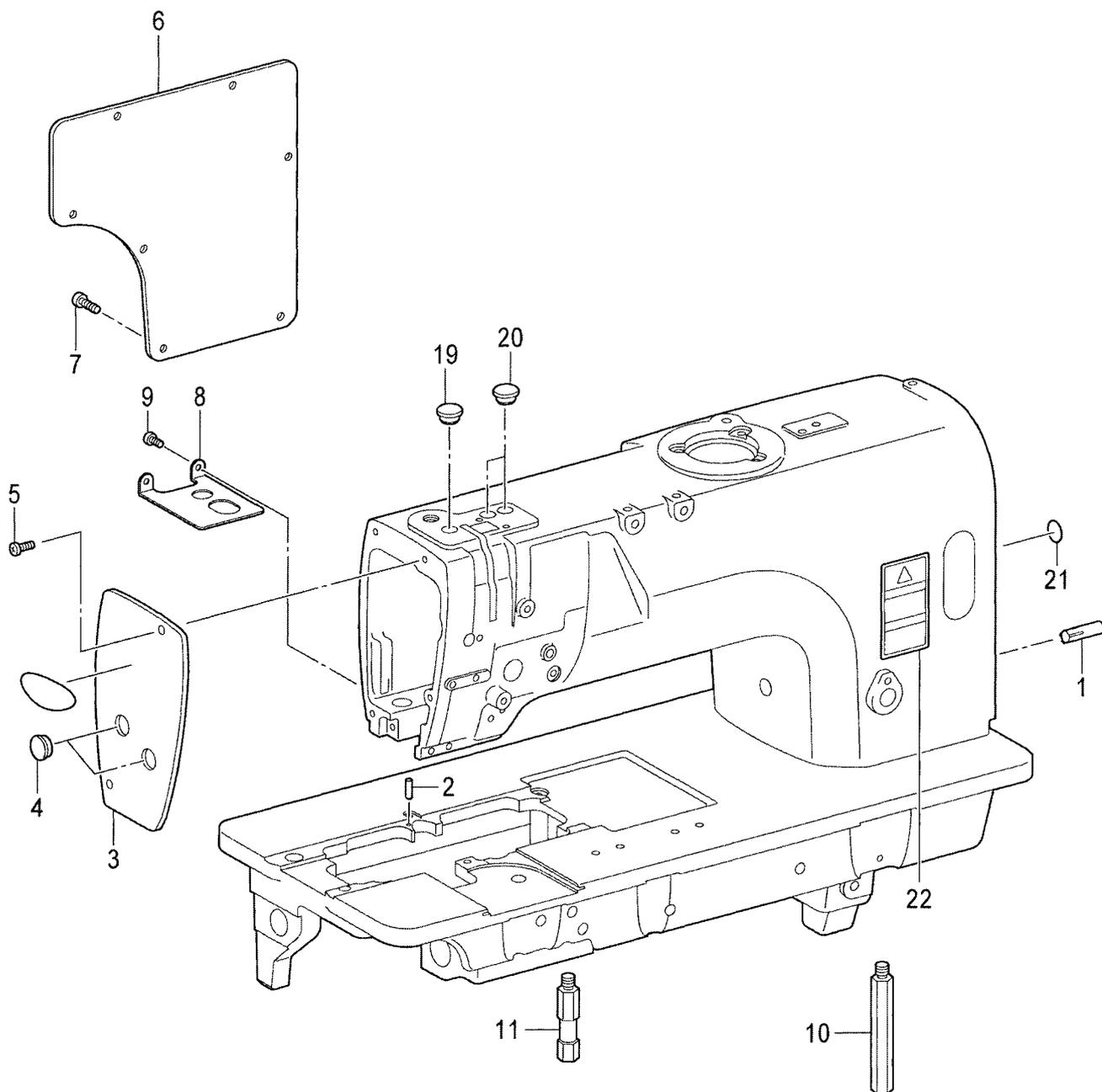

" オプション部品 / OPTION PARTS "

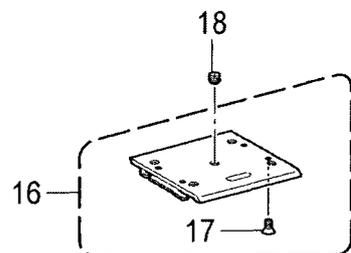
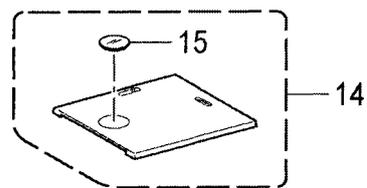
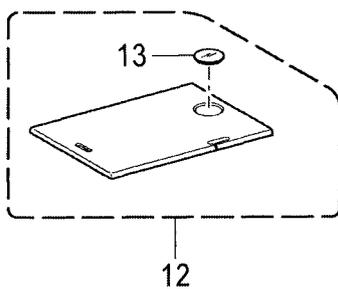
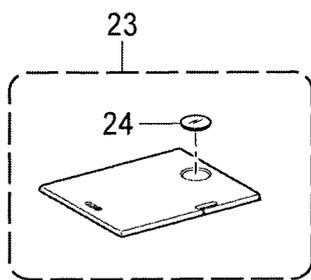

A. 主体関係 / Machine body

REF.NO	CODE	Q'TY	品名	NAME OF PARTS	RM
1	140063001	1	ミゾツキピン	DOWEL PIN	
2	SA3924001	1	ハリイタイチキメピン	POSITIONING PIN	
3	SA2440001	1	メンイタ	FACE PLATE	
4	SA2929001	2	ゴムセン12.5	RUBBER CAP, 12.5	
5	062500816	2	ナベコ5X8	SCREW PAN M5X8	
6	SA2441001	1	ガワイタ	REAR COVER	
7	062501216	7	ナベコ5X12	SCREW PAN M5X12	
8	SA2443001	1	ダストプレート	DUST PROTECTOR	
9	062500616	2	ナベコ5X6	SCREW PAN M5X6	
10	SA2444001	1	キヤクチュウL	BED LEG,L	
11	SA2445001	1	キヤクチュウS	BED LED,S	
12	SA2447001	1	スベリイタLAクミ	SLIDE PLATE, LA ASSY	
13	SA2479001	1	スベリイタマド	BOBBIN WINDOW	
14	SA2449001	1	スベリイタRクミ	SLIDE PLATE ASSY, R	
15	SA2479001	1	スベリイタマド	BOBBIN WINDOW	
16	S36663051	1	スベリイタFクミ	SLIDE PLATE F ASSY	
17	S34438051	4	サラネジ3.18X4	SCREW, FLAT SM3.18-40X4	
18	116010001	1	トメネジ5.16	SET SCREW, SM5.16-40X4	
19	SA2929001	1	ゴムセン12.5	RUBBER CAP, 12.5	
20	SA2929001	2	ゴムセン12.5	RUBBER CAP, 12.5	
21	S37060001	1	アースマーク	LABEL, GROUNDING	
			<日本向>	<For Japan only>	
22	SA2040001	1	ラベルチュウイ.ワエイ	LABEL, CAUTION JPN/ENG	
			<日本向以外>	<For Except Japan>	
22	SA2041001	1	ラベルチュウイ.チュウエイ	LABEL, CAUTION CHN/ENG	
			<オプション部品>	<OPTION PARTS>	
23	SA2761001	1	スベリイタLBクミ	SLIDE PLATE, LB ASSY	
24	SA2479001	1	スベリイタマド	BOBBIN WINDOW	

B. 上軸関係 / Upper shaft mechanism

< 微量給油仕様 -□0□用 / For "-□0□" Minimum lubrication type >

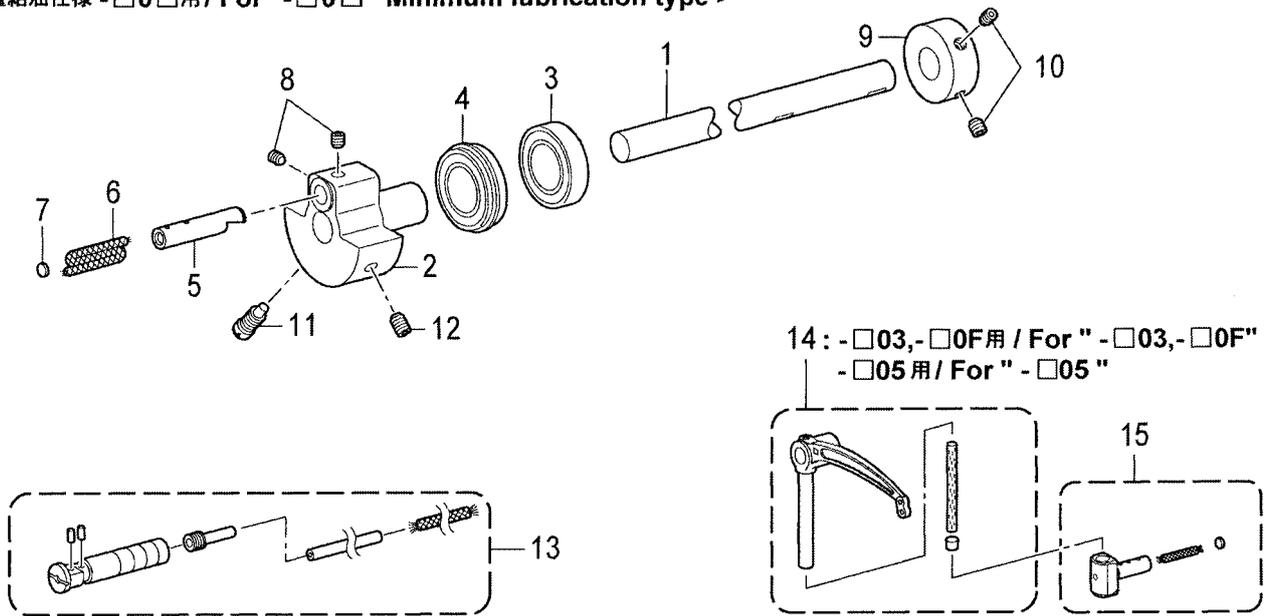

< セミドライ仕様 -□3□用 / For "-□3□" Semi dry type >

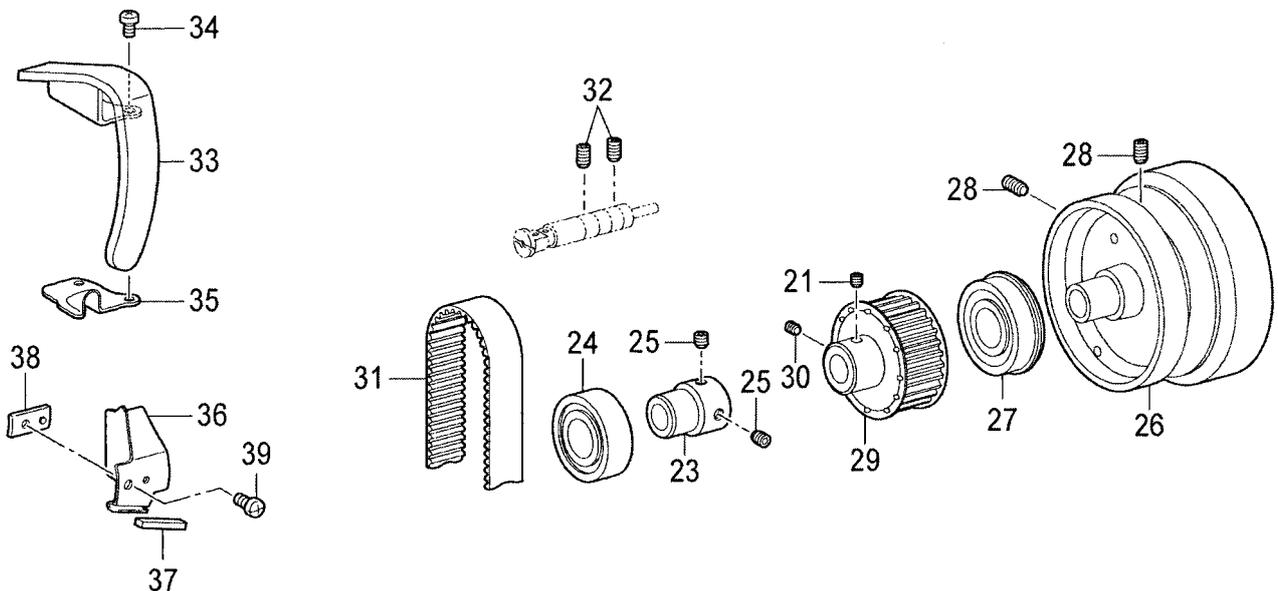
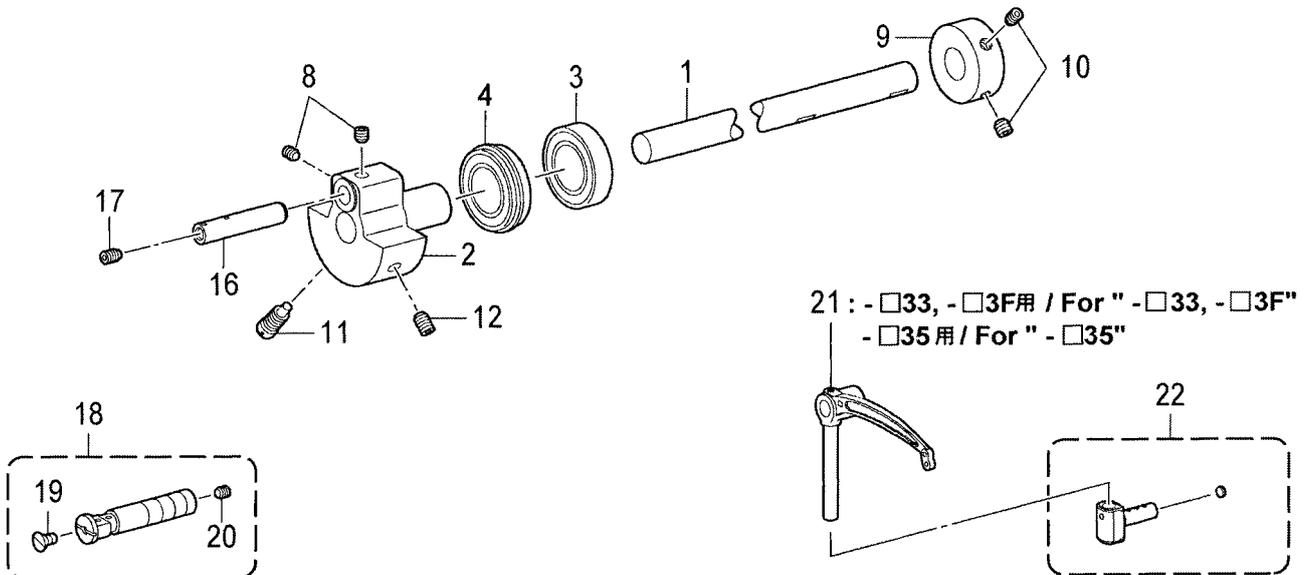

B. 上軸関係 / Upper shaft mechanism

REF.NO	CODE	Q'TY	品名	NAME OF PARTS	RM
1	SA2746201	1	<-□0□用> ウワジクST	<For "-□0□"> UPPER SHAFT, ST	
2	SA4089001	1	テンビクラック	THREAD TAKE-UP CRANK	
3	S25234001	1	タマジクウケ6004ZZ	BALL BEARING, 6004ZZ	
4	S38707001	1	タマジクウケ6004ZZNR	BALL BEARING, 6004ZZNR	
5	S38398001	1	ハリボウクラックジク	CRANKSHAFT, N-BAR	
6	SA4335001	1	クミヒモ4X4	WICK,4X4(L=90)	
7	113014000	1	クミヒモフタ	PUSHER	
8	S25260001	2	アナヒラ6X5ホソメ	SET SCREW, SOCKET (FT) M6X5	
9	SA1120001	1	イトマキドウリン	BOBBIN WINDER DRIVING WHEEL	
10	S23651001	2	アナヒラ6X6ホソメ	SET SCREW, SOCKET (FT) M6X6	
11	S25235001	1	シメネジ8	SCREW, M8	
12	S25236001	1	アナヒラ6X10ホソメ	SET SCREW, SOCKET (FT) M6X10	
13	SA2861001	1	テンビンササエジクソウクミ	THREAD TAKE-UP S-SHAFT UNIT	
14	SA2935101	1	<-□03,-□0F用> テンビンS3-Lクミ	<For "-□03,-□0F"> THREAD TAKE-UP LEVER ASSY,S3-L	
14	SA2936101	1	<-□05用> テンビンS5-Lクミ	<For "-□05"> THREAD TAKE-UP LEVER ASSY,S5-L	
15	S13160001	1	<-□0□用> テンビンスベリコ2クミ	<For "-□0□"> T-TAKE-UP SLIDE BLOCK ASSY, 2	
1	SA2746201	1	<-□3□用> ウワジクST	<For "-□3□"> UPPER SHAFT, ST	
2	SA4089001	1	テンビクラック	THREAD TAKE-UP CRANK	
3	S25234001	1	タマジクウケ6004ZZ	BALL BEARING, 6004ZZ	
4	S38707001	1	タマジクウケ6004ZZNR	BALL BEARING, 6004ZZNR	
16	SA4112001	1	テンビクラックジクP	THREAD TAKE-UP CRANK SHAFT, P	
17	014500836	1	アナクボミ5X8	SET SCREW SOCKET (CP) M5X8	
8	S25260001	2	アナヒラ6X5ホソメ	SET SCREW, SOCKET (FT) M6X5	
9	SA1120001	1	イトマキドウリン	BOBBIN WINDER DRIVING WHEEL	
10	S23651001	2	アナヒラ6X6ホソメ	SET SCREW, SOCKET (FT) M6X6	
11	S25235001	1	シメネジ8	SCREW, M8	
12	S25236001	1	アナヒラ6X10ホソメ	SET SCREW, SOCKET (FT) M6X10	
18	SA2464001	1	テンビンササエジククミ	THREAD TAKE-UP S-SHAFT ASSY	
19	SA2958001	1	サラネジ5X6	SCREW, FLAT M5X6	
20	012500536	1	アナヒラ5X5	SET SCREW SOCKET (FT) M5X5	
21	SA4115001	1	<-□33,-□3F用> テンビンS3P	<For "-□33,-□3F"> THREAD TAKE-UP LEVER, S3 P	
21	SA4116001	1	<-□35用> テンビンS5P	<For "-□35"> THREAD TAKE-UP LEVER, S5 P	
22	SA4129001	1	<-□3□用> テンビンスベリコクミ	<For "-□3□"> THREAD TAKE-UP SLIDE B-ASSY	
23	SA2748001	1	タマジクウケブツシュ	BALL BEARING BUSH	
24	076023800	1	Rタマジクウケ60/22ZZ	BALL BEARING RADIAL 60/22ZZ	
25	S23651001	2	アナヒラ6X6ホソメ	SET SCREW, SOCKET (FT) M6X6	
26	SA2750001	1	プーリ	PULLY	
27	158115001	1	タマジクウケ6204ZZNR	BALL BEARING, 6204ZZNR	
28	012061036	2	アナヒラ6X10	SET SCREW SOCKET (FT) M6X10	
29	SA2720001	1	タイミングプーリU STクミ	TIMING PULLEY ASSY,U ST	
30	SA4214001	2	アナトメネジ6X6ホソメ	SET SCREW, SOCKET (CP) M6X6	
31	SA2463001	1	タイミングベルト	TIMING BELT	
32	012061036	2	アナヒラ6X10	SET SCREW SOCKET (FT) M6X10	
33	SA2469001	1	テンビンカバー	THREAD TAKE-UP LEVER COVER	
34	062500816	2	ナベコ5X8	SCREW PAN M5X8	
35	SA3057001	1	ダストカバー	DUST COVER	
36	SA3058101	1	シヤヘイバン	SHELTER PLATE	
37	SA3065001	1	フェルト	FELT	
38	SA3059001	1	シヤヘイバンオサエ	HOLDER, SHELTER PLATE	
39	062500816	1	ナベコ5X8	SCREW PAN M5X8	

C. 針棒揺動関係 / Needle bar rocking mechanism

< 微量給油仕様 - □0□用 / For "-□0□" Minimum lubrication type >

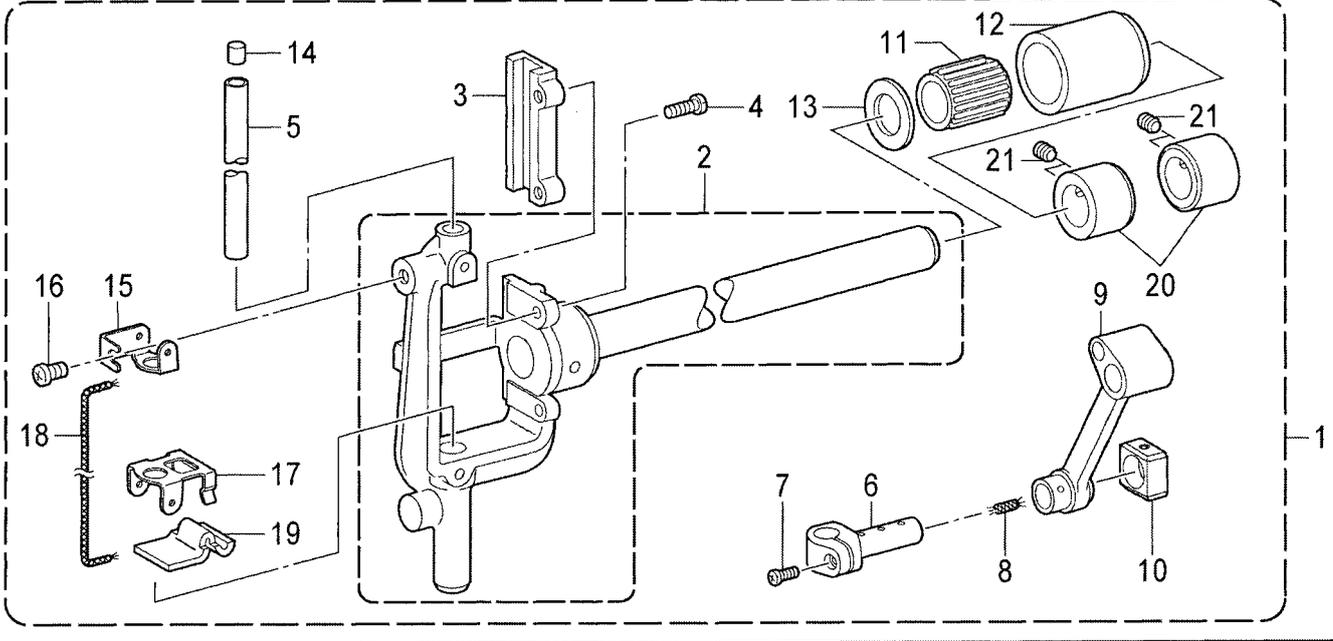

< セミドライ仕様 - □3□用 / For "-□3□" Semi dry type >

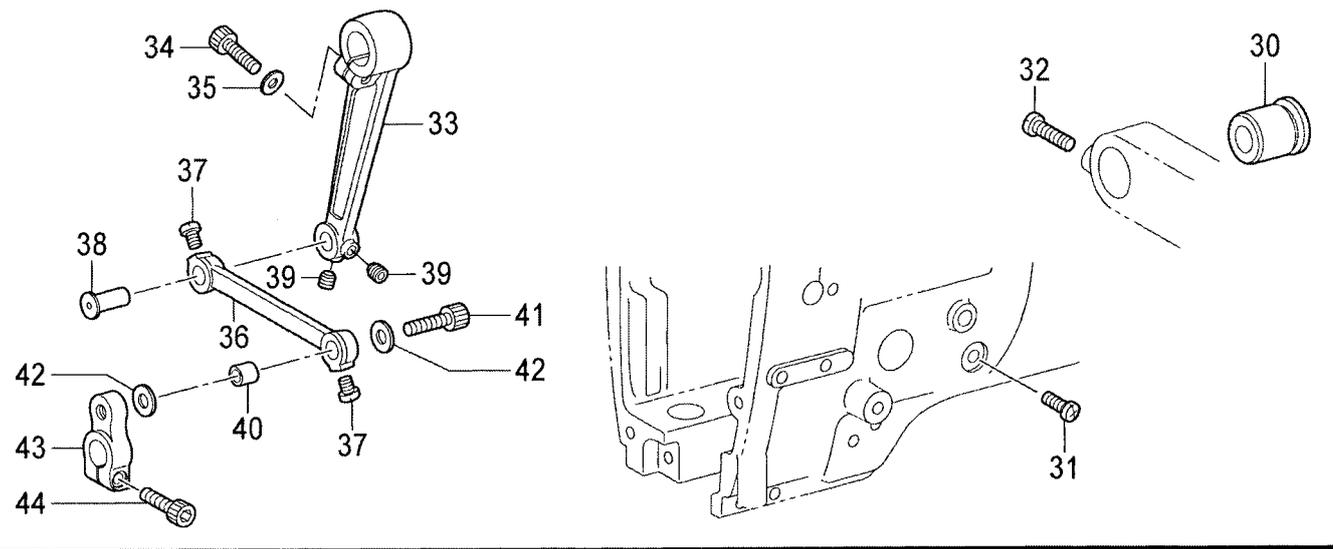
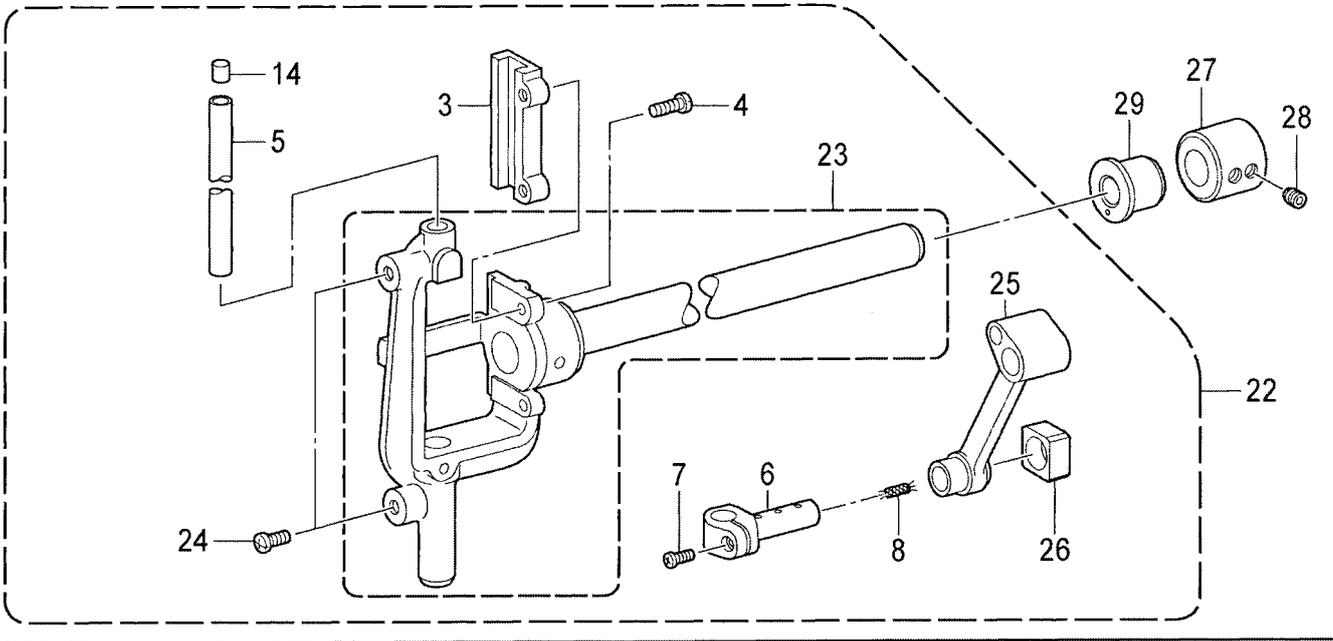

## C. 針棒揺動関係 / Needle bar rocking mechanism

REF.NO	CODE	Q'TY	品名	NAME OF PARTS	RM
			<-□0□用>	<For "-□0□">	
1	SA4124101	1	ハリボウヨウドウジククミ	NEEDLE BAR ROCKER SHAFT ASSY	
2	SA3854001	1	ハリボウダイクミ	NEEDLE BAR BASE ASSY	
3	SA2474101	1	カクコマスライダ	SLIDE BLOCK SLIDER	
4	062401016	2	ナベコ4X10	SCREW PAN M4X10	
5	SA2475001	1	ハリボウ	NEEDLE BAR	
6	SA3710001	1	ハリボウダキ	NEEDLE BAR CLAMP	
7	062350816	1	ナベコ35X8	SCREW PAN M3.5X8	
8	112728001	1	クミヒモ	WICK, L=50	
9	SA3711001	1	ハリボウクランクロッド	CRANK ROD,N-BAR	
10	SA3712001	1	カクコマ	SLIDE BLOCK	
11	SA2482001	1	ニードルベアリング	NEEDLE BEARING	
12	SA2483001	1	ケース	CASE	
13	SA2484001	1	ザガネ	WASHER,PLAIN	
14	148394000	1	ハリボウセン	CAP, N-BAR	
15	SA4007001	1	フェルトオサエU	FELT SUPPORT, U	
16	062500616	1	ナベコ5X6	SCREW PAN M5X6	
17	SA3848001	1	フェルトオサエD	FELT SUPPORT, D	
18	S07465000	1	クミヒモ	WICK, L=200	
19	SA3852001	1	フェルト	FELT	
20	SA2485001	2	セットカラー	SET SCREW COLLAR	
21	S25260001	4	アナヒラ6X5ホソメ	SET SCREW,SOCKET (FT) M6X5	
			<-□3□用>	<For "-□3□">	
22	SA4093001	1	ハリボウヨウドウジククミ	NEEDLE BAR ROCKER SHAFT ASSY	
23	SA2471001	1	ハリボウダイクミ	NEEDLE BAR BASE ASSY	
24	062500816	2	ナベコ5X8	SCREW PAN M5X8	
3	SA2474101	1	カクコマスライダ	SLIDE BLOCK SLIDER	
4	062401016	2	ナベコ4X10	SCREW PAN M4X10	
5	SA2475001	1	ハリボウ	NEEDLE BAR	
6	SA3710001	1	ハリボウダキ	NEEDLE BAR CLAMP	
7	062350816	1	ナベコ35X8	SCREW PAN M3.5X8	
8	112728001	1	クミヒモ	WICK, L=50	
25	SA4094001	1	ハリボウクランクロッド	CRANK ROD, N-BAR	
26	SA2481001	1	カクコマ	SLIDE BLOCK	
14	148394000	1	ハリボウセン	CAP, N-BAR	
27	SA2485001	1	セットカラー	SET SCREW COLLAR	
28	S25260001	2	アナヒラ6X5ホソメ	SET SCREW,SOCKET (FT) M6X5	
29	SA4095001	1	ヨウドウジクメタルL	BUSH, L	
30	SA2486101	1	ヨウドウジクメタルR	BUSH, R	
31	062500816	1	ナベコ5X8	SCREW PAN M5X8	
32	062061616	1	ナベコ6X16	SCREW PAN M6X16	
33	SA2489001	1	ハリボウヨウドウレバー	NEEDLE BAR ROCKER LEVER ASSY	
34	018062032	1	アナボルト6X20	BOLT SOCKET M6X20	
35	118735002	1	ザガネ	WASHER	
36	SA2490101	1	ハリボウヨウドウリンク	ROCKER LINK, N-BAR	
37	S23460001	2	ナベコ6X5	SCREW, PAN M6X5	
38	SA4117001	1	ヨウドウリンクジクP	LINK SHAFT, N-BAR ROCKER P	
39	012060636	2	アナヒラ6X6	SET SCREW SOCKET (FT) M6X6	
40	SA4118001	1	ヨウドウリンクカラP	ZIGZAG LINK BUSH, P	
41	018062532	1	アナボルト6X25	BOLT SOCKET M6X25	
42	SA2493001	2	ザガネ	WASHER,PLAIN	
43	SA2494001	1	ハリボウヨウドウウデ	NEEDLE BAR ROCK ARM	
44	018062032	1	アナボルト6X20	BOLT SOCKET M6X20	

D. 押え関係 / Presser foot mechanism

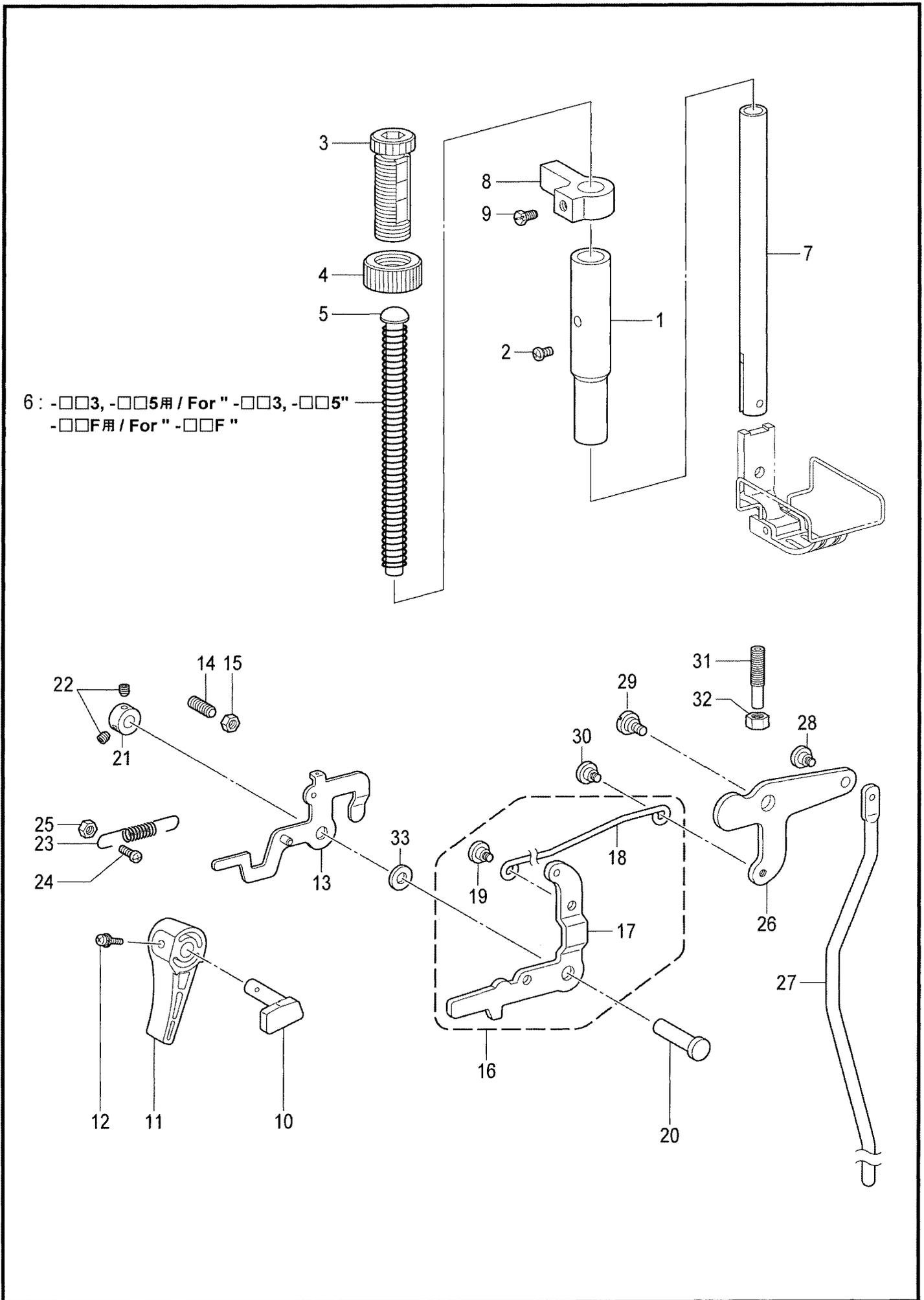

## D. 押え関係 / Presser foot mechanism

REF.NO	CODE	Q'TY	品名	NAME OF PARTS	RM
1	SA2495001	1	オサエボウメタル	PRESSER BAR BUSH	
2	062500816	1	ナベコ5X8	SCREW PAN M5X8	
3	SA1174001	1	オサエチヨウセツネジM14	PRESSER ADJUSTING SCREW, M14	
4	SA1175001	1	チヨウセツネジナットM14	ADJUST SCREW NUT	
5	141208001	1	オサエバネアンナイ	SPRING GUIDE	
6	S07346101	1	オサエバネ <-□□3,-□□5用>	<For "-□□3,-□□5"> PRESSER BAR SPRING, -5	
6	S16196001	1	オサエバネ <-□□F用>	<For "-□□F"> PRESSER BAR SPRING, F	
7	SA2496001	1	オサエボウ	PRESSER BAR	
8	SA2498001	1	オサエボウダキ	GUIDE BRACKET, P-BAR	
9	S25289001	1	ボルト6	BOLT, (CP) M6X10	
10	SA2499001	1	オサエアゲクランク	PRESSER BAR LIFTING CRANK	
11	S31006001	1	オサエアゲテコ	LIFTING LEVER	
12	S39051001	1	ナベザクミ35X12	SCREW, PAN (S/P W) M3.5X12	
13	S07353001	1	イトユルメイタクミ	TENSION RELEASE PLATE ASSY	
14	012061832	1	アナヒラ6X18	SET SCREW, SOCKET (FT) M6X18	
15	021060306	1	3シュナット6	NUT 3 M6	
16	SA2500001	1	ヒザアゲレンカクミ	KNEE LIFTER C-ROD ASSY	
17	SA2501001	1	オサエアゲレバー	PRESSER BAR LIFTING LEVER	
18	SA2502001	1	ヒザアゲレンカン	KNEE LIFTER CONNECTING ROD	
19	SA1179001	1	ダンネジ5	SHOULDER SCREW, M5	
20	S07349001	1	オサエアゲレバージク	P-BAR LIFTING LEVER SHAFT	
21	SA2504001	1	セットカラー	SET SCREW COLLAR	
22	012500536	2	アナヒラ5X5	SET SCREW SOCKET (FT) M5X5	
23	S07355051	1	オサエアゲレバーバネ	SPRING, EXTENSION	
24	062501416	1	ナベコ5X14	SCREW PAN M5X14	
25	021500106	1	1シュナット5	NUT 1 M5	
26	SA2506001	1	ヒザアゲレバー	KNEE LIFTER LEVER	
27	SA2507001	1	ヒザアゲボウ	KNEE LIFTER BAR	
28	SA1179001	1	ダンネジ5	SHOULDER SCREW, M5	
29	SA2165001	1	ダンネジ6	SHOULDER SCREW, M6	
30	SA1179001	1	ダンネジ5	SHOULDER SCREW, M5	
31	SA4149001	1	チヨウセツネジ6	ADJUSTING SCREW, 6	
32	021060306	1	3シュナット6	NUT 3 M6	
33	S07350001	1	ザガネ	WASHER,PLAIN	

E. 送り関係 / Feed mechanism

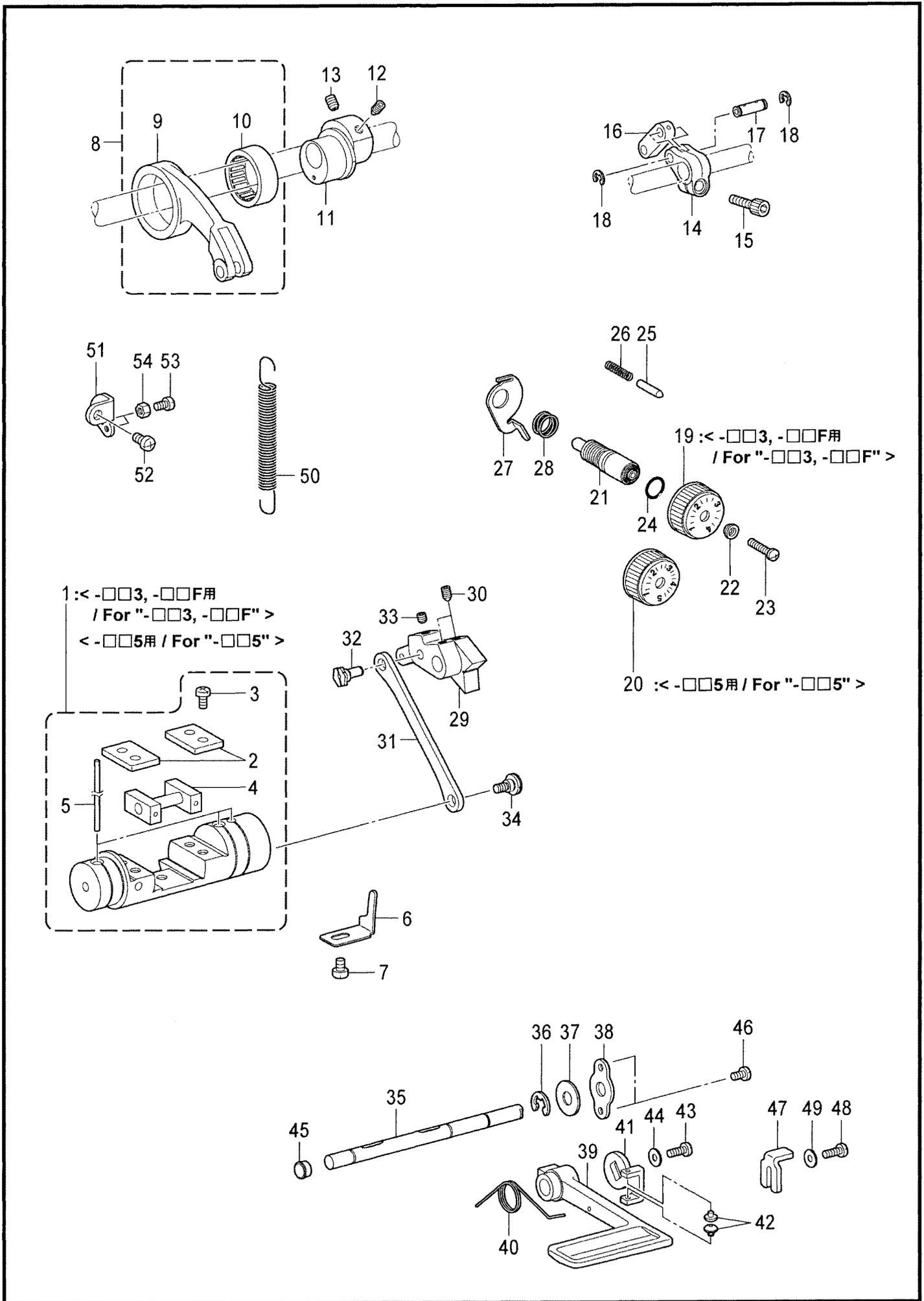

## E. 送り関係 / Feed mechanism

REF.NO	CODE	Q'TY	品名	NAME OF PARTS	RM
1	SA3062001	1	<-□□3,-□□5用> キリカエキ11クミ	<For "-□□3,-□□5"> FEED REGULATOR ASSY, 11	
1	SA2509001	1	<-□□5用> キリカエキクミ	<For "-□□5"> FEED REGULATOR ASSY	
2	SA2511001	2	カクコマアンナイイタ	GUIDE PLATE	
3	062501016	4	ナベコ5X10	SCREW PAN M5X10	
4	SA2512001	1	キリカエキカクコマクミ	SLIDE BLOCK ASSY	
5	SA2515001	3	フェルト	FELT	
6	SA2516001	1	キリカエキトメ	STOPEER	
7	062060816	1	ナベコ6X8	SCREW PAN M6X8	
8	143611201	1	スイヘイオクリレンカンクミ	F-ROCKER CONNECTING ROD ASSY	
9	143612100	1	スイヘイオクリレンカン	FEED ROCKER CONNECTING ROD	
10	118954000	1	ニードルベアリング	NEEDLE BEARING	
11	SA2518001	1	スイヘイヘンシンリン5	LEVEL FEED ECCENTRIC WHEEL 5	
12	SA2585001	1	アナトガリ6X10ホソメ	SET SCREW, SOCKET (FT) M6	
13	S25236001	1	アナヒラ6X10ホソメ	SET SCREW, SOCKET (FT) M6X10	
14	SA2521001	1	スイヘイオクリウデ5	FEED ROCKER ARM 5	
15	018062032	1	アナボルト6X20	BOLT SOCKET M6X20	
16	143613051	1	スイヘイオクリウデリンク	LINK	
17	143616001	1	スイヘイオクリウデジク	SHAFT	
18	048060342	2	トメワE6	RETAINING RING E6	
19	S38422001	1	<-□□3,-□□F用> オクリメモリダイヤル	<For "-□□3,-□□F"> STITCH LENGTH DIAL, 4	
20	S38427001	1	<-□□5用> オクリメモリダイヤル	<For "-□□5"> STITCH LENGTH DIAL, 5	
21	SA3056001	1	オクリチヨウセツネジ	FEED REGULATING STUD	
22	142746002	1	メモリイタオサエ	FEED REGULATING SUPPORTER	
23	129458102	1	シメネジ4.76	SCREW, SM4.76	
24	108549001	1	Oリング	O RING	
25	S50098101	1	メモリイチギメピン	POSITIONING PIN	
26	100328001	1	メモリイチキメピンバネ	NOTCH SPRING	
27	SA2523001	1	ダイヤルロックレバー	DIAL LOCK LEVER	
28	S39830101	1	ダイヤルロックレバーバネ	SPRING	
29	SA2525001	1	オクリチヨウセツキ5	FEED REGULATOR 5	
30	016061031	2	アナトガリ6X10	SET SCREW SOCKET (CN) M6X10	
31	SA2526001	1	キリカエキレンカン	CONNECTING ROD	
32	SA2527001	1	ヘンシンジク	ECCENTRIC SHAFT	
33	012060636	1	アナヒラ6X6	SET SCREW SOCKET (FT) M6X6	
34	SA2528101	1	ダンネジ6	SHOULDER SCREW, M6	
35	SA2529101	1	カエシヌイレバージクTR	SHAFT, R-LEVER TR	
36	048080342	1	トメワE8	RETAINING RING E8	
37	025100132	1	ヒラザガネシヨウ10	WASHER PLAIN S 10	
38	SA2530001	1	カンザ	SPACER	
39	S07374109	1	カエシヌイレバー	REVERSE STITCHING LEVER	
40	SA2531001	1	カエシヌイレバーオサエバネ	SPRING	
41	SA3067001	1	レバーガイド	LEVER GUIDE	
42	S48367000	2	レバーガイドゴム	RUBBER	
43	062501216	1	ナベコ5X12	SCREW PAN M5X12	
44	025050336	1	ヒラザガネダイ5	WASHER PLAIN L 5	
45	104821001	1	ゴムセン10.5	RUBBER CAP, 10.5	
46	062500816	2	ナベコ5X8	SCREW PAN M5X8	
47	SA2532001	1	ハンドルストツパ	STOPPER	
48	062501216	1	ナベコ5X12	SCREW PAN M5X12	
49	025050236	1	ヒラザガネチュウ5	WASHER PLAIN M 5	
50	S07376001	1	キリカエキバネ	FEED REGULATOR SPRING	
51	SA2533001	1	バネカケ	SPRING HOOK	
52	062060816	1	ナベコ6X8	SCREW PAN M6X8	
53	062501216	1	ナベコ5X12	SCREW PAN M5X12	
54	021500106	1	1シュナット5	NUT 1 M5	

F. 送り軸関係 / Feed shaft mechanism

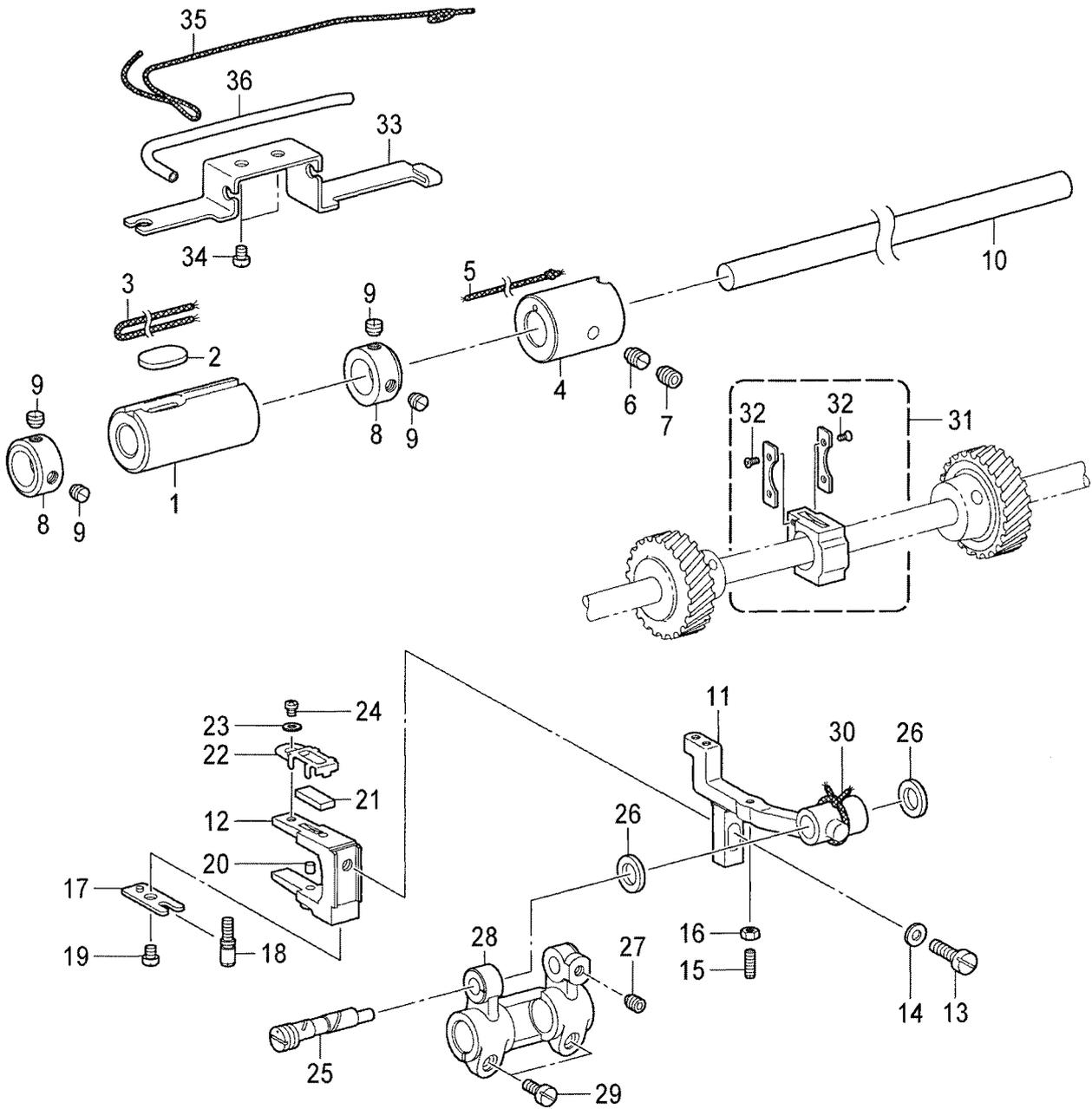

"オプション部品 / OPTION PARTS" <ドライ仕様用 / Dry Type >

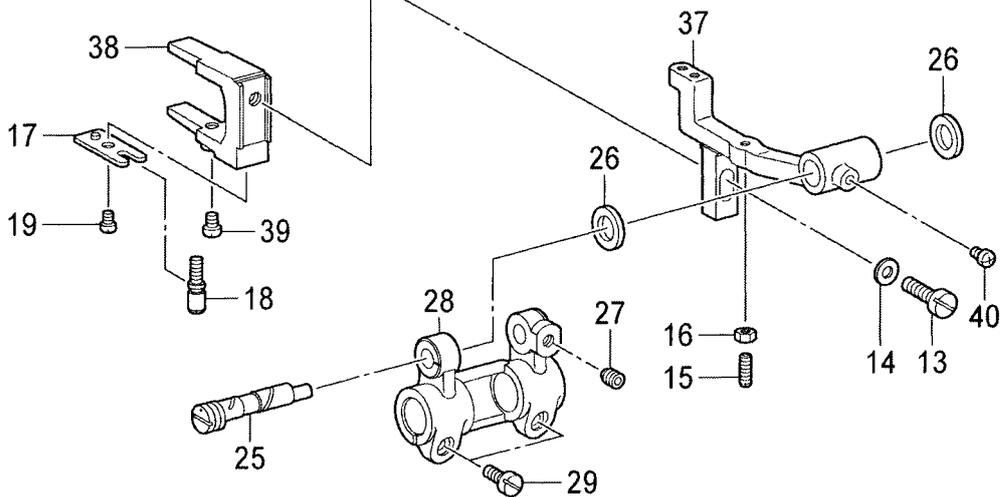

F. 送り軸関係 / Feed shaft mechanism

REF.NO	CODE	Q'TY	品名	NAME OF PARTS	RM
1	SA3855001	1	オクリジクメタルL	BUSH,L:F-ROCKER SHAFT	
2	SA3965001	1	フェルト	FELT	
3	SA4028001	1	クミヒモ4X4 L=220	WICK, 4X4 L=220	
4	SA2543001	1	オクリジクメタルR	FEED ROCKER SHAFT BUSH, R	
5	108802001	1	クミヒモ4X4	WICK, 4X4 L=250	
6	SA2544001	1	トメネジM6	SET SCREW M6	
7	012060636	1	アナヒラ6X6	SET SCREW SOCKET (FT) M6X6	
8	SA2546001	2	セットカラー	SET SCREW COLLAR	
9	S23651001	4	アナヒラ6X6ホソメ	SET SCREW, SOCKET (FT) M6X6	
10	SA3840001	1	スイヘイオクリジク	FEED ROCKER SHAFT	
11	SA3864001	1	オクリダイST	FEED BAR,ST	
12	SA3886001	1	オクリダイフタマタ	FEED BAR FORK	
13	SA2927001	1	シメネジM6X14	SCREW, M6X14	
14	025060132	1	ヒラザガネショウ6	WASHER PLAIN S 6	
15	SA2566001	1	トメネジ3.5	SET SCREW, M3.5	
16	021350106	1	1シュナット35	NUT 1 M3.5	
17	SA2553001	1	フタマタプレート	FORKED PLATE	
18	SA2554001	1	タカサチヨウセツネジ	ADJUSTING SCREW ,HIGHT	
19	062400616	1	ナベコ4X6	SCREW PAN M4X6	
20	SA3990001	1	フェルト	FELT	
21	SA3887001	1	フェルト	FELT	
22	SA3888001	1	フェルトオサエ	FELT HOLDER	
23	025030132	1	ヒラザガネショウ3	WASHER PLAIN S 3	
24	062300416	1	ナベコ3X4	SCREW PAN M3X4	
25	SA2550001	1	オクリダイトリツケジク	FEED BAR SHAFT	
26	SA2551001	2	スラストリング	THRUST RING	
27	012060636	1	アナヒラ6X6	SET SCREW SOCKET (FT) M6X6	
28	SA2555001	1	スイヘイオクリダイウデ	FEED ROCKER BASE ARM	
29	SA2928001	2	シメネジM5X12	SCREW, M5X12	
30	SA4025001	1	クミヒモ4X4 L=180	WICK, 4X4 L=180	
31	SA2806001	1	オクリダイカクコマクミ	FEED BAR SLIDE BLOCK ASSY	
32	W01519001	4	0サラコ3シユ2X4	SCREW, FLAT #0 M2X4	
33	SA4009001	1	クミヒモササエ	WICK SUPPORT	
34	062400616	2	ナベコ4X6	SCREW PAN M4X6	
35	SA2724001	1	クミヒモ	WICK, L=400	
36	SA4011001	1	ビニルチューブ L=100	OIL TUBE, L=100	
			<オプション部品>ドライ仕様用	<OPTION PARTS>Dry Type	
37	SA2754001	1	オクリダイST	FEED BAR, ST	
38	SA2552001	1	オクリダイフタマタ	FEED BAR FORK	
39	062500816	1	ナベコ5X8	SCREW PAN M5X8	
40	062500616	1	ナベコ5X6	SCREW PAN M5X6	

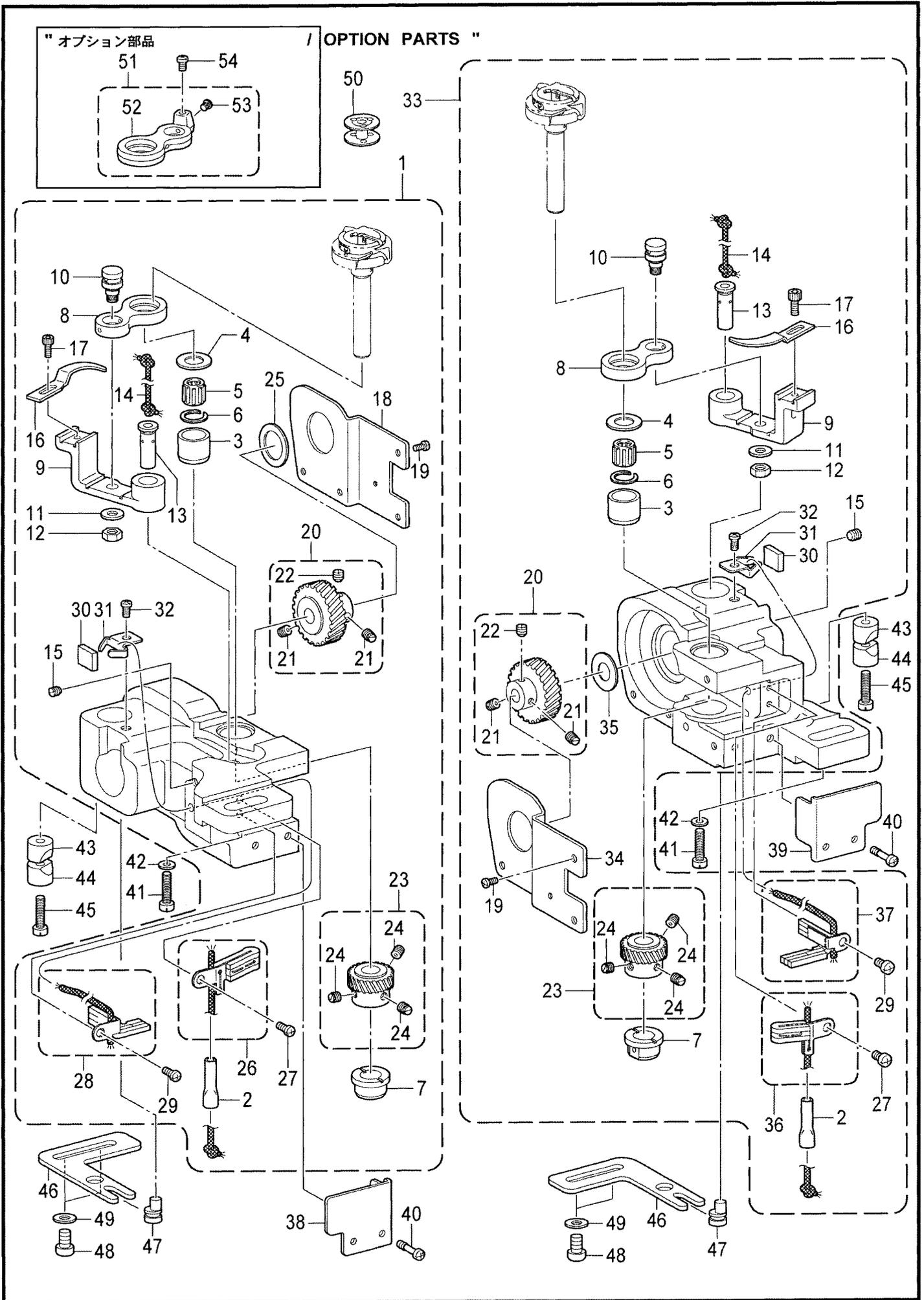

## G1. カマ関係 / Rotary hook mechanism

REF.NO	CODE	Q'TY	品名	NAME OF PARTS	RM
1	SA2755101	1	<-□□3,-□□F用> カマドダイ842ST(L)クミ	<For "-□□3,-□□F"> ROTARY HOOK BASE ASSY,842ST(L)	
1	SA2950101	1	<-□□5用> カマドダイ842ST-5Lクミ	<For "-□□5"> ROTARY HOOK BASE ASSY,842ST-5L	
2	SA3961001	1	パイプ	PIPE	
3	SA4029001	1	カマジクメタルU	ROTARY HOOK SHAFT BUSH	
4	S09260001	1	スラストリングA <t=1.2>	THRUST RING, A :1.2MM <t=1.2>	
4	SA4038001	1	スラストリング <t=1.0>	THRUST RING <t=1.0>	
4	S09261001	1	スラストリングB <t=1.4>	THRUST RING, B :1.4MM <t=1.4>	
4	SA4444001	1	スラストリング0.8 <t=0.8>	THRUST RING 0.8MM <t=0.8>	
5	S07420000	1	ニードルベアリング	NEEDLE BEARING	
6	S07419001	1	ストツプリング	RETAINING RING	
7	SA2557001	1	カマジクメタルD	ROTARY HOOK SHAFT BUSH	
8	SA3856001	1	オープナーリンク	OPENER LINK	
9	SA3859001	1	オープナーレバー	OPENER LEVER	
10	SA2560001	1	オープナーリンクジク	SHAFT, O-LINK	
11	025710132	1	ヒラザガネシヨウ4.76	WASHER PLAIN S SM4.76	
12	021500316	1	3シュナット5	NUT 3 M5	
13	SA3889101	1	オープナーレバージク	O-LEVER SHAFT	
14	SA4026001	1	クミヒモ4X4 L=100	WICK, 4X4 L=100	
15	012500536	1	アナヒラ5X5	SET SCREW SOCKET (FT) M5X5	
16	S38212001	1	オープナー	OPENER	
17	154965001	1	アナボルト3.57X8	BOLT, SOCKET SM3.57X8	
18	SA2562101	1	カマドダイカバーL	ROTARY HOOK BASE COVER, L	
19	062300612	4	ナベコ3X6	SCREW PAN M3X6	
20	SA4549001	1	スパイラルギア ネジツキ	SPIRAL GEAR SCREW ASSY	
21	SA2574001	2	トメネジM6ホソメ	SET SCREW, (FT) M6	
22	SA2575001	1	トメネジM6ホソメ	SET SCREW, (FT) M6	
23	SA2576001	1	ピニオン ネジツキ	PINION GEAR SCREW ASSY	
24	SA2574001	3	トメネジM6ホソメ	SET SCREW, (FT) M6	
25	SA3054001	1	スラストザガネL	THRUST WASHER, L	
26	SA4042001	1	フェルトULクミ	FELT UL ASSY	
27	062400616	1	ナベコ4X6	SCREW PAN M4X6	
28	SA4044001	1	フェルトDLクミ	FELT DL ASSY	
29	062400616	1	ナベコ4X6	SCREW PAN M4X6	
30	SA4012001	1	フェルト	FELT	
31	SA3894001	1	フェルトオサエ	FELT SUPPORT	
32	062400616	1	ナベコ4X6	SCREW PAN M4X6	
33	SA2757201	1	<-□□3,-□□F用> カマドダイ842ST(L)	<For "-□□3,-□□F"> ROTARY HOOK BASE,842ST(L)	
33	SA2951101	1	<-□□5用> カマドダイ842ST-5Rクミ	<For "-□□5"> ROTARY HOOK BASE ASSY,842ST-5R	
2	SA3961001	1	パイプ	PIPE	
3	SA4029001	1	カマジクメタルU	ROTARY HOOK SHAFT BUSH	
4	S09260001	1	スラストリングA	THRUST RING, A :1.2MM	
4	SA4038001	1	スラストリング	THRUST RING	
4	S09261001	1	スラストリングB	THRUST RING, B :1.4MM	
4	SA4444001	1	スラストリング0.8	THRUST RING 0.8MM	
5	S07420000	1	ニードルベアリング	NEEDLE BEARING	
6	S07419001	1	ストツプリング	RETAINING RING	
7	SA2557001	1	カマジクメタルD	ROTARY HOOK SHAFT BUSH	
8	SA3856001	1	オープナーリンク	OPENER LINK	
9	SA3859001	1	オープナーレバー	OPENER LEVER	
10	SA2560001	1	オープナーリンクジク	SHAFT, O-LINK	
11	025710132	1	ヒラザガネシヨウ4.76	WASHER PLAIN S SM4.76	
12	021500316	1	3シュナット5	NUT 3 M5	
13	SA3889101	1	オープナーレバージク	O-LEVER SHAFT	
14	SA4026001	1	クミヒモ4X4 L=100	WICK, 4X4 L=100	
15	012500536	1	アナヒラ5X5	SET SCREW SOCKET (FT) M5X5	

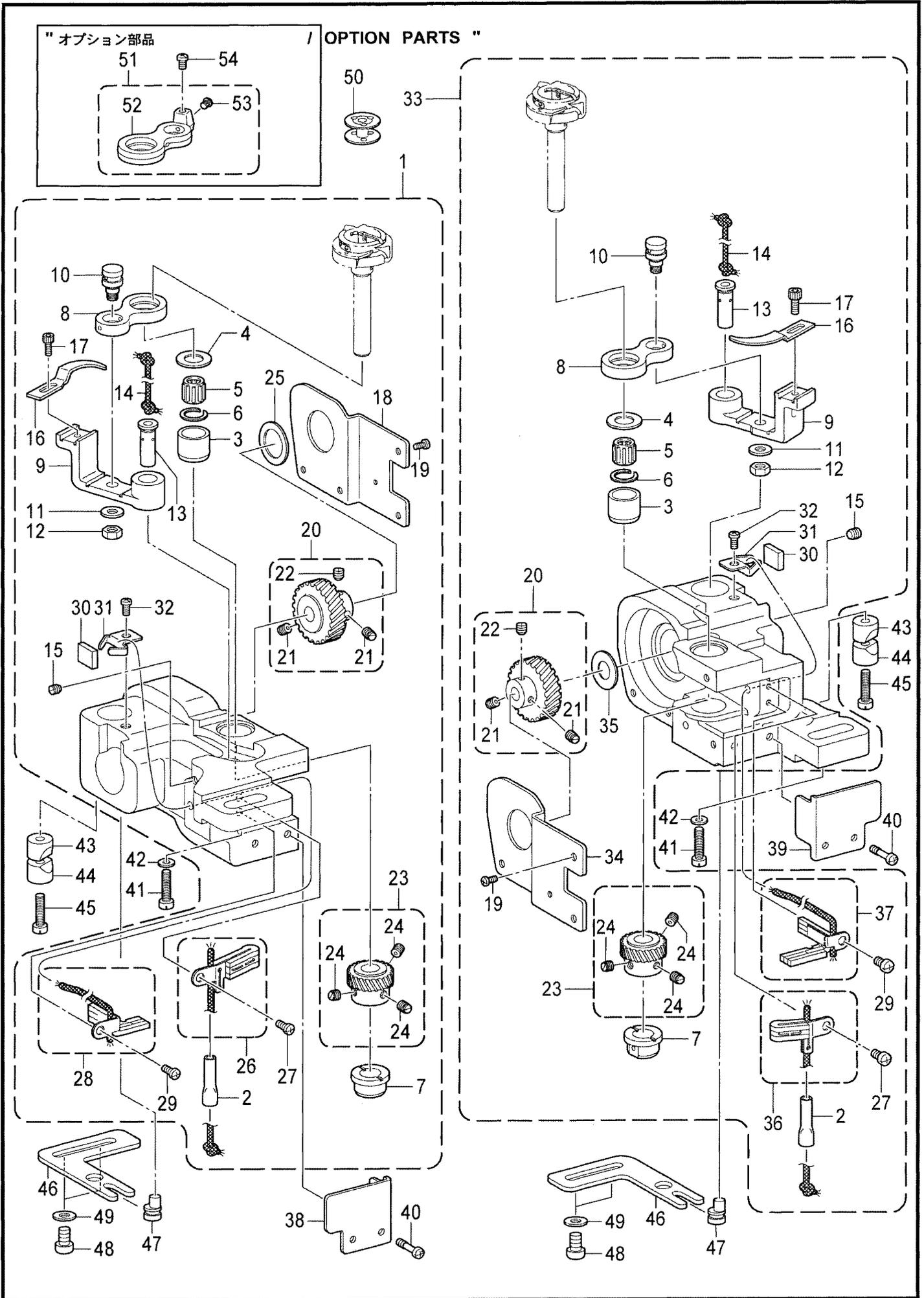

G1. カマ関係 / Rotary hook mechanism

REF.NO	CODE	Q'TY	品名	NAME OF PARTS	RM
16	S38212001	1	オープナー	OPENER	
17	154965001	1	アナボルト3.57X8	BOLT, SOCKET SM3.57X8	
34	SA2563101	1	カマダイカバー-R	ROTARY HOOK BASE COVER, R	
19	062300612	4	ナベコ3X6	SCREW PAN M3X6	
20	SA4549001	1	スパイラルギア ネジツキ	SPIRAL GEAR SCREW ASSY	
21	SA2574001	2	トメネジM6ホソメ	SET SCREW, (FT) M6	
22	SA2575001	1	トメネジM7ホソメ	SET SCREW, (FT) M7	
23	SA2576001	1	ピニオン ネジツキ	PINION GEAR SCREW ASSY	
24	SA2574001	3	トメネジM6ホソメ	SET SCREW, (FT) M6	
35	SA2579001	1	スラストザガネ	SPECER	
36	SA4043001	1	フェルトURクミ	FELT UR ASSY	
27	062400616	1	ナベコ4X6	SCREW PAN M4X6	
37	SA4045001	1	フェルトDRクミ	FELT DR ASSY	
29	062400616	1	ナベコ4X6	SCREW PAN M4X6	
30	SA4012001	1	フェルト	FELT	
31	SA3894001	1	フェルトオサエ	FELT SUPPORT	
32	062400616	1	ナベコ4X6	SCREW PAN M4X6	
<hr/>					
38	SA3988001	1	カマダイカバー-FL	ROTARY HOOK BASE COVER, FL	
39	SA3916001	1	カマダイカバー-FR	ROTARY HOOK BASE COVER, FR	
40	SA2825001	2	シメネジM3X12	SCREW, M3X12	
41	SA2556001	2	シメネジM6X25	SCREW, M6X25	
42	115947001	2	ザガネ	WASHER, PLAIN 6.35	
43	SA2722001	2	ピンチスリーブA	PINCH SLEEVE A	
44	SA2565001	2	ピンチスリーブB	PINCH SLEEVE B	
45	SA2556001	2	シメネジM6X25	SCREW, M6X25	
46	SA2567001	2	ハリスキチヨウセツイタ	NEEDLE UPPER ADJUSTING PLATE	
47	SA2568001	2	ハリスキチヨウセツジク	NEEDLE UPPER POSITIONING SHAFT	
48	062061016	4	ナベコ6X10	SCREW PAN M6X10	
49	025060136	4	ヒラザガネシヨウ6	WASHER PLAIN S 6	
50	S01928151	2	ボビン	BOBBIN	
			<オプション部品>	<OPTION PARTS>	
			<T-8420A ドライ仕様用>	<For "T-8420A" Dry Type>	
51	SA2827001	2	オープナーリンククミ	OPENER LINK ASSY	
52	SA2558001	2	オープナーリンク	OPENER LINK	
53	S58900000	2	セイミツネジM2	SCREW, M2	
54	062400416	2	ナベコ4X4	SCREW, PAN M4X4	

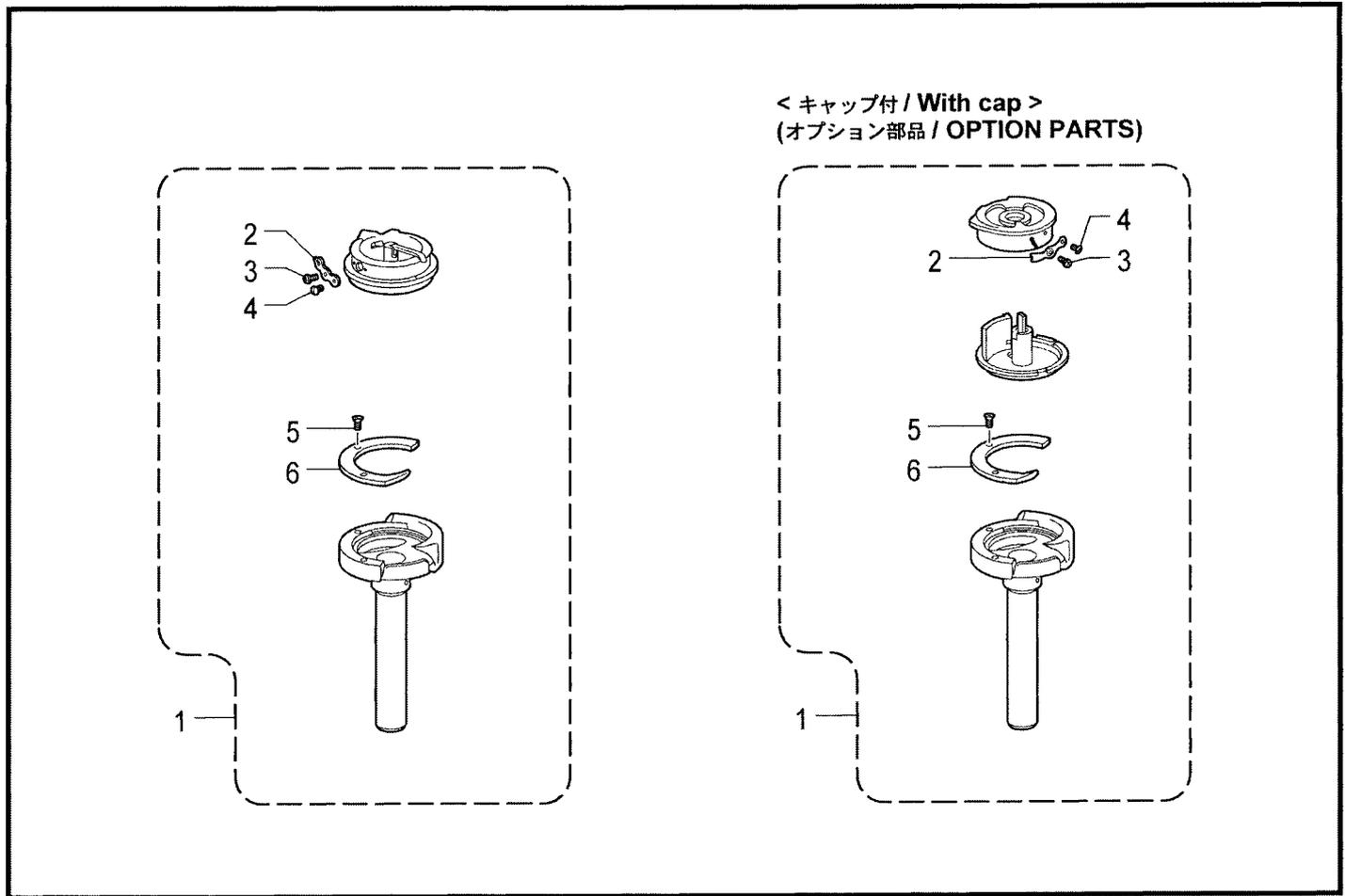

T-8420B-301

H . ゲージ関係 / Gauge parts

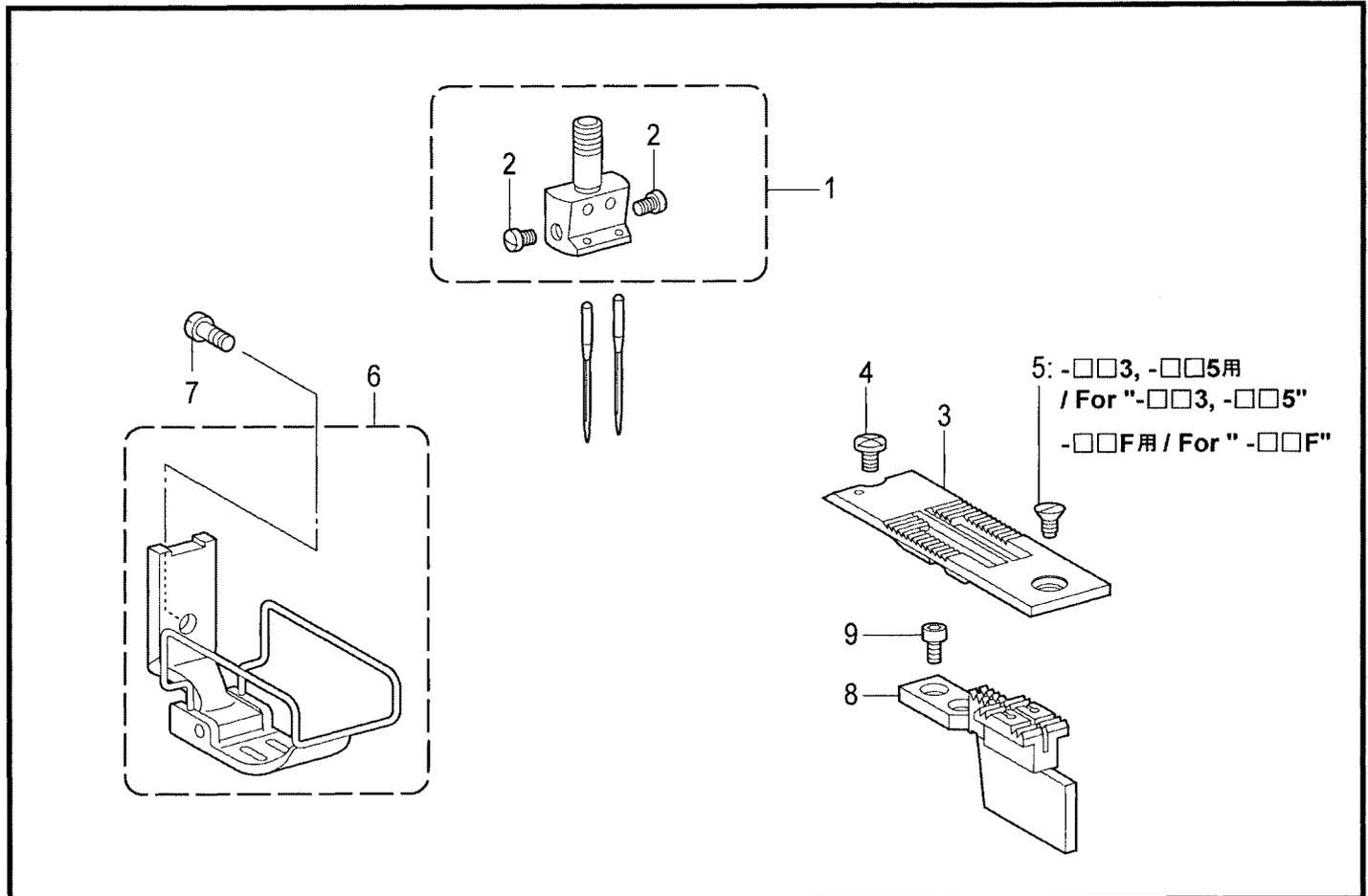

T-8420B-231

G2. カマ関係 / Rotary hook mechanism

REF.NO	CODE	Q'TY	品名	NAME OF PARTS	RM
1	*	1	カマハコクミ		
2	*	1	チヨウシバネ	TENSION SPRING	
3	*	1	チヨウシネジ	TENSION ADJUSTING SCREW	
4	151030001	1	チヨウシバネトメネジ	SET SCREW	
5	151027001	2	ウチカマオサエトメネジ	SET SCREW	
6	S07746001	1	ウチカマオサエ	INNER ROTARY HOOK HOLDER	
<p>* については、仕様別部品一覧表(P.34)でお調べください。 As for symbol * look it up in the different parts list on page 34.</p>					

T-8420B-301

H. ゲージ関係 / Gauge parts

REF.NO	CODE	Q'TY	品名	NAME OF PARTS	RM
1	*	1	ハリダキクミ	NEEDLE CLAMP ASSY	
2	116323001	2	シメネジ3.57	SCREW, SM3.57	
3	*	1	ハリイタ	NEEDLE PLATE	
4	S11244001	1	シメネジ4.37 <-□□3,-□□5用>	SCREW, SM4.37 <For "-□□3,-□□5">	
5	100032004	1	サラネジ4.37 <-□□F用>	SCREW, FLAT SM4.37-40X8 <For "-□□F">	
5	117160001	1	サラネジ4.37	SCREW, FLAT SM4.37	
6	*	1	オサエクミ	PRESSER FOOT ASSY	
7	113050001	1	シメネジ3.57	SCREW, SM3.57	
8	*	1	オクリバ	FEED DOG	
9	S07494001	2	シメネジ3.18	SCREW, W/SOCKET SM3.18X7	
<p>* については、ゲージ部品一覧表(P.35-41)でお調べください。 As for symbol * look it up in the gauge parts list on page 35-41 .</p>					

T-8420B-231

J. 下軸関係 / Lower shaft mechanism

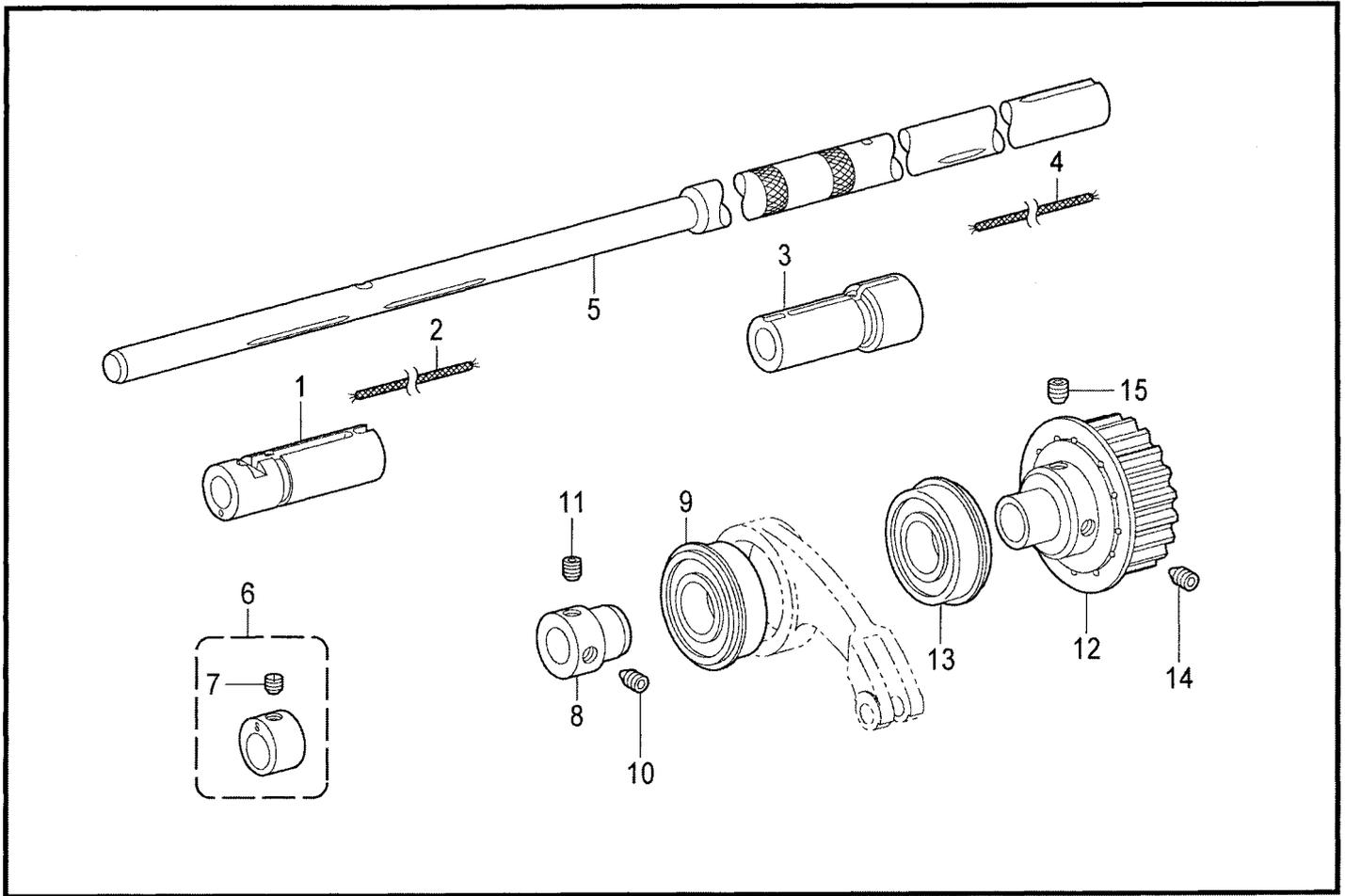

T-8420B-305

K. 電装品関係(- □3 □) / Power supply equipment mechanism (For "- □3 □")

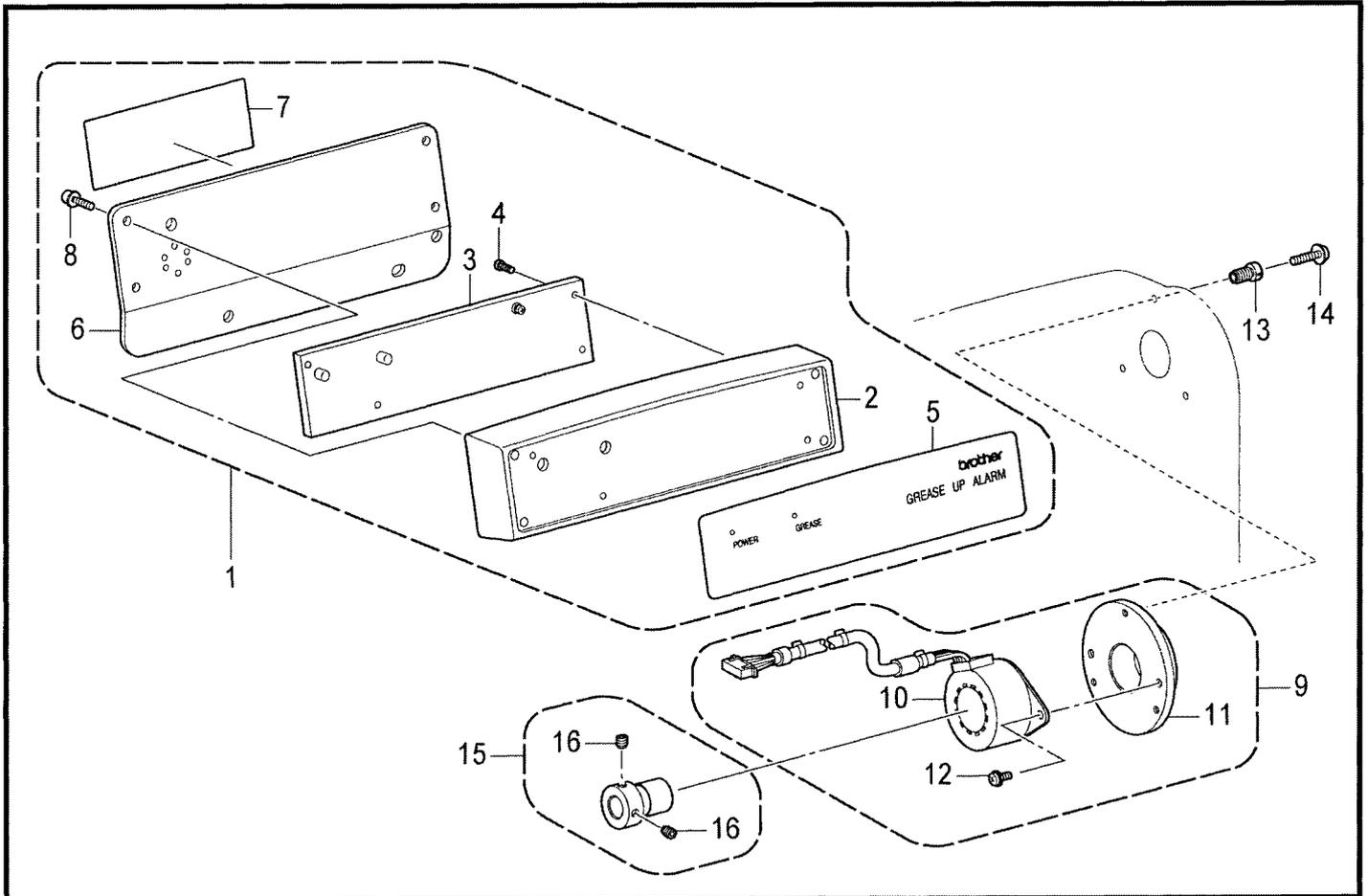

T-8420B-515

J. 下軸関係 / Lower shaft mechanism

REF.NO	CODE	Q'TY	品名	NAME OF PARTS	RM
1	SA3890001	1	カマドダイメタルL	ROTARY HOOK BASE BUSH, L	
2	S38481000	1	クミヒモ	WICK, L=41	
3	SA3891001	1	カマドダイメタルR	ROTARY HOOK BASE BUSH, R	
4	S38481000	1	クミヒモ	WICK, L=41	
5	SA2571001	1	シタジク	LOWER SHAFT	
6	SA2759001	1	ジヨウゲヘンシンリンSTクミ	F-LIFTING ECCENTRIC WHEEL ASSY	
7	SA2575001	1	トメネジM6ホソメ	SET SCREW, (FT) M6	
8	SA2584001	1	タマジクウケブツシュ	BALL BEARING BUSH	
9	072600480	1	Tタマジクウケ6004ZZ	BALL BEARING, THRUST 6004ZZ	
10	SA2585001	1	アナトガリ6X10ホソメ	SET SCREW, SOCKET (FT) M6	
11	S25236001	1	アナヒラ6X10ホソメ	SET SCREW, SOCKET (FT) M6X10	
12	SA2587001	1	タイミングプーリDクミ	TIMING PULLEY ASSY, D	
13	158115001	1	タマジクウケ6204ZZNR	BALL BEARING, 6204ZZNR	
14	SA2585001	1	アナトガリ6X10ホソメ	SET SCREW, SOCKET (FT) M6	
15	SA4213001	1	アナトメネジ6X10ホソメ	SET SCREW, SOCKET (CP) M6X10	

T-8420B-305

K. 電装品関係 (-□3□用) / Power supply equipment mechanism (For "-□3□")

REF.NO	CODE	Q'TY	品名	NAME OF PARTS	RM
1	J04352001	1	アラームディスプレイクミ	ALARM DISPLAY ASSY	
2	J04353001	1	アラームディスプレイケース	ALARM DISPLAY CASE	
3	J04357001	1	アラームヒョウジキバンクミ	PCB ASSY, ALARM DISPLAY	
4	037300816	4	Vナベタッピン3X8	TAPPING SCREW PAN V M3X8	
5	J04355001	1	アラームラベル	ALARM LABEL	
6	J04354001	1	アラームディスプレイホルダ	ALARM DISPLAY HOLDER	
7	J04356001	1	リセットラベル	RESET LABEL	
8	J04273001	4	ナベザクミ4X10DB	SCREW, PAN(S/P WASHER)M4X10	
9	J04310001	1	PMステータソウクミ4843	PM STATOR BASE ASSY, 484323	
10	J04340001	1	PMステータクミ484323	PM STATOR ASSY, 484323	
11	J04339001	1	PMステータベース	PM STATOR BASE	
12	0A4400806	2	+ナベザクミ4X8DA	SCREW PAN (S/P WASHER) M4X8	
13	J04338001	3	スペーサM8X18	SPACER M8X18	
14	0A4402506	3	+ナベザクミ4X25DA	SCREW PAN (S/P WASHER) M4X25	
15	J04311001	1	RクミD22.5P24	ROTOR ASSY, D22.5P24	
16	012060636	2	アナヒラ6X6	SET SCREW SOCKET (FT) M6X6	

T-8420B-515

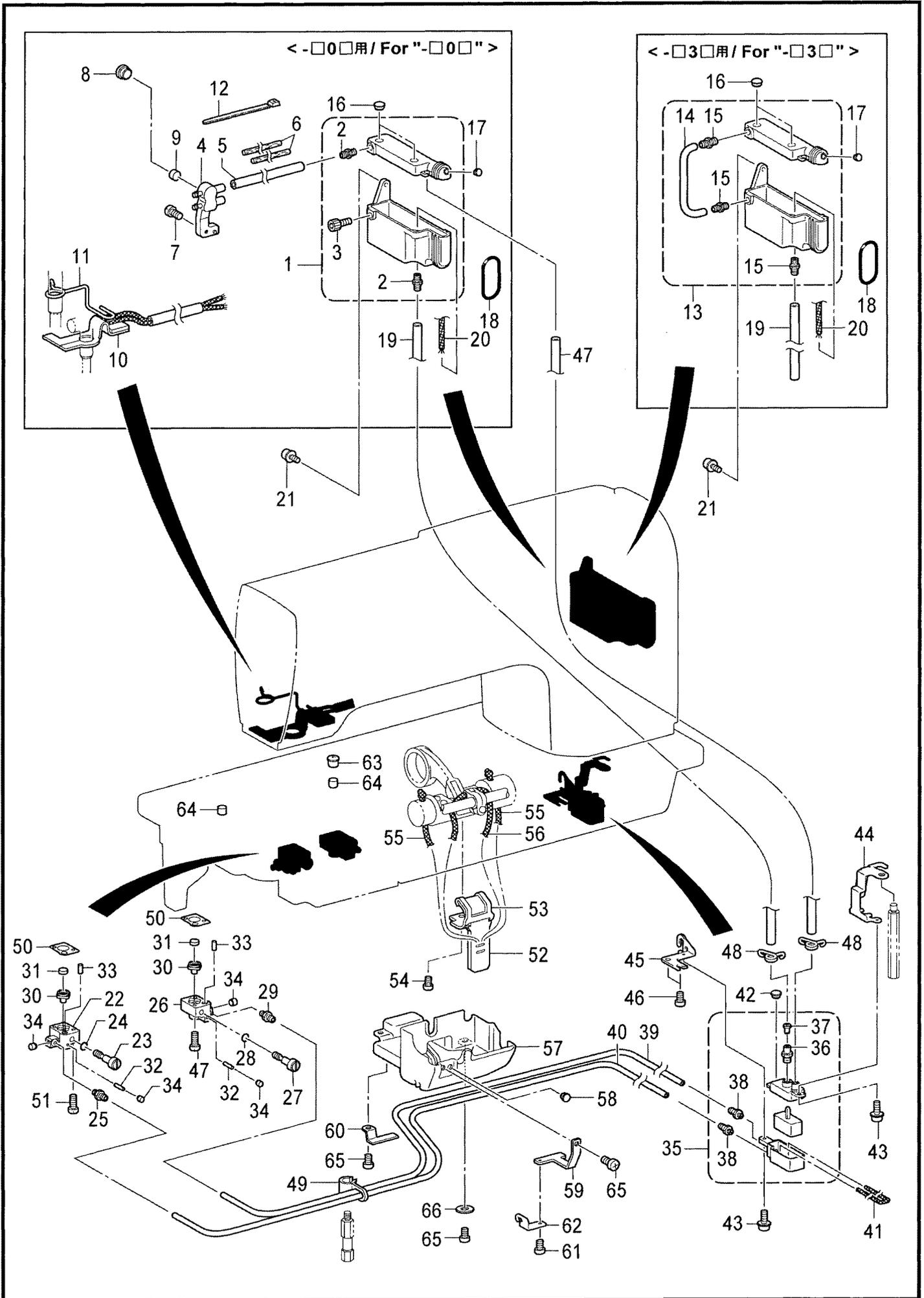

## L. 給油潤滑関係 / Lubrication

REF.NO	CODE	Q'TY	品名	NAME OF PARTS	RM
			<-□0□用>	<For "-□0□">	
1	SA4205001	1	オイルタンククミ	OIL TANK ASSY	
2	S51815001	2	オイルクチ8.6	OIL FEEDING PIPE, 8.6	
3	018081236	1	アナボルト8X12	BOLT SOCKET M8X12	
4	SA3946001	1	キュウユタ-ミナル	OIL TERMINAL	
5	SA2956001	1	ビニルチューブ	OIL TUBE, L=135	
6	SA2957001	2	フェルト	FELT	
7	062500816	1	ナベコ5X8	SCREW PAN M5X8	
8	SA2929001	2	ゴムセン12.5	RUBBER CAP, 12.5	
9	S38266000	1	カマジクフェルト	ROTARY HOOK SHAFT FELT	
10	SA4215001	1	フェルトクミ	FELT ASSY	
11	SA4033001	1	フェルトオサエ	FELT SUPPORT	
12	228475000	1	ケツソクバンド1.9X80	FASTENING BAND, 1.9X80	
			<-□3□用>	<For "-□3□">	
13	SA2814101	1	オイルタンククミ	OIL TANK ASSY	
14	SA3949001	1	ビニルチューブ L=50	OIL TUBE, L=50	
15	S51815001	3	オイルクチ8.6	OIL FEEDING PIPE, 8.6	
16	SA2929001	2	ゴムセン12.5	RUBBER CAP, 12.5	
17	104450101	1	ゴムセン8	RUBBER CAP, 8	
18	081038070	1	OリングP38	O RING P38	
19	SA2723001	1	ビニルチューブ	OIL TUBE, L=210	
20	SA2724001	1	クミヒモ	WICK, L=400	
21	0A5501006	2	+ナベザクミ5X10DB	SCREW PAN (S/P WASHER) M5X10	
22	SA3896001	1	キュウユブロックL	OIL BLOCK,L	
23	SA2599001	1	オイルチヨウセツネジ	OIL ADJUSTING SCREW	
24	081004070	1	OリングP4	O RING P4	
25	SA3147001	1	オイルクチ2.5	OIL FEEDING PIPE 2.5	
26	SA3898001	1	キュウユブロックR	OIL BLOCK,R	
27	SA2599001	1	オイルチヨウセツネジ	OIL ADJUSTING SCREW	
28	081004070	1	OリングP4	O RING P4	
29	SA3147001	1	オイルクチ2.5	OIL FEEDING PIPE 2.5	
30	SA3061001	2	ゴムパツキン	RUBBER PACKING	
31	SA2727101	2	カマジクフェルト	ROTARY HOOK SHAFT FELT	
32	S05246000	2	フェルト	FELT	
33	148743001	2	フェルト	FELT	
34	142274101	4	ゴムセン4.2	RUBBER CAP, 4.2	
35	SA3037001	1	サブタンククミ	SUB-TANK ASSY	
36	SA3040001	1	オイルクチ	OIL FEEDING PIPE	
37	SA3060001	1	バルブパツキン	VALVE PACKING	
38	SA3147001	2	オイルクチ2.5	OIL FEEDING PIPE 2.5	
39	SA2596001	1	ビニルチューブ	OIL TUBE, L=400	
40	SA2597001	1	ビニルチューブ	OIL TUBE, L=500	
41	SA2598001	1	クミヒモ	WICK, L=1100	
42	104450101	1	ゴムセン8	RUBBER CAP, 8	
43	0A4400806	2	+ナベザクミ4X8DA	SCREW PAN (S/P WASHER) M4X8	
44	SA3045101	1	サブタンクトリツケイタA	SUB-TANK SETTING PLATE, A	
45	SA3046001	1	サブタンクトリツケイタB	SUB-TANK SETTING PLATE, B	
46	062060816	2	ナベコ6X8	SCREW PAN M6X8	
47	SA3044001	1	ビニルチューブ	OIL TUBE, L=242	
48	SA3055101	2	チューブストツパー	TUBE CLIP	
49	SA3047001	1	チューブササエ	TUBE SUPPORT	
50	SA3923001	2	カマドダイDパツキン	ROTARY HOOK BASE D PACKING	
51	062401616	4	ナベコ4X16	SCREW PAN M4X16	
52	SA2604001	1	キリカエキフェルト	FEED REGULATOR FELT	
53	SA2605001	1	フェルトオサエイタ	FELT SUPPORT	
54	062500616	1	ナベコ5X6	SCREW PAN M5X6	
55	108802001	2	クミヒモ4X4	WICK, 4X4 L=250	
56	108801001	1	クミヒモ4X4	WICK, 4X4 L=350	
57	SA2606101	1	オイルカバー	OIL COVER	
58	104450101	1	ゴムセン8	RUBBER CAP, 8	
59	SA3048101	1	チューブオサエA	TUBE SUPPORT, A	

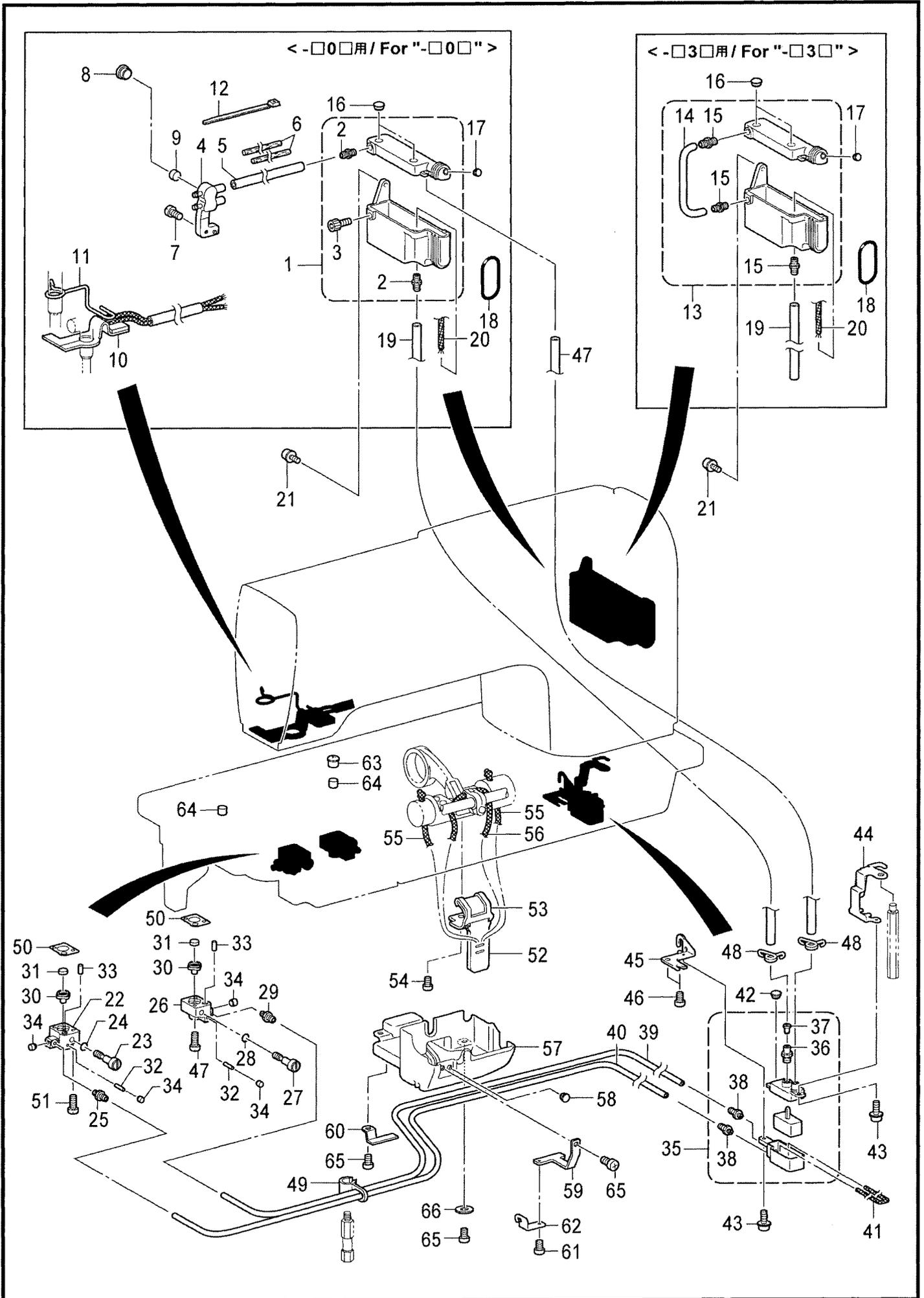

## L. 給油潤滑関係 / Lubrication

REF.NO	CODE	Q'TY	品名	NAME OF PARTS	RM
60	SA3049001	1	チューブオサエB	TUBE SUPPORT, B	
62	062400616	1	ナベコ4X6	SCREW PAN M4X6	
61	SA4014001	1	チューブガイド	TUBE GUIDE	
63	140890009	1	オイルカツブ	OIL CAP	
64	112753001	2	フェルト	FELT	
65	062061016	3	ナベコ6X10	SCREW PAN M6X10	
66	025060236	1	ヒラザガネチュウ6	WASHER PLAIN M 6	

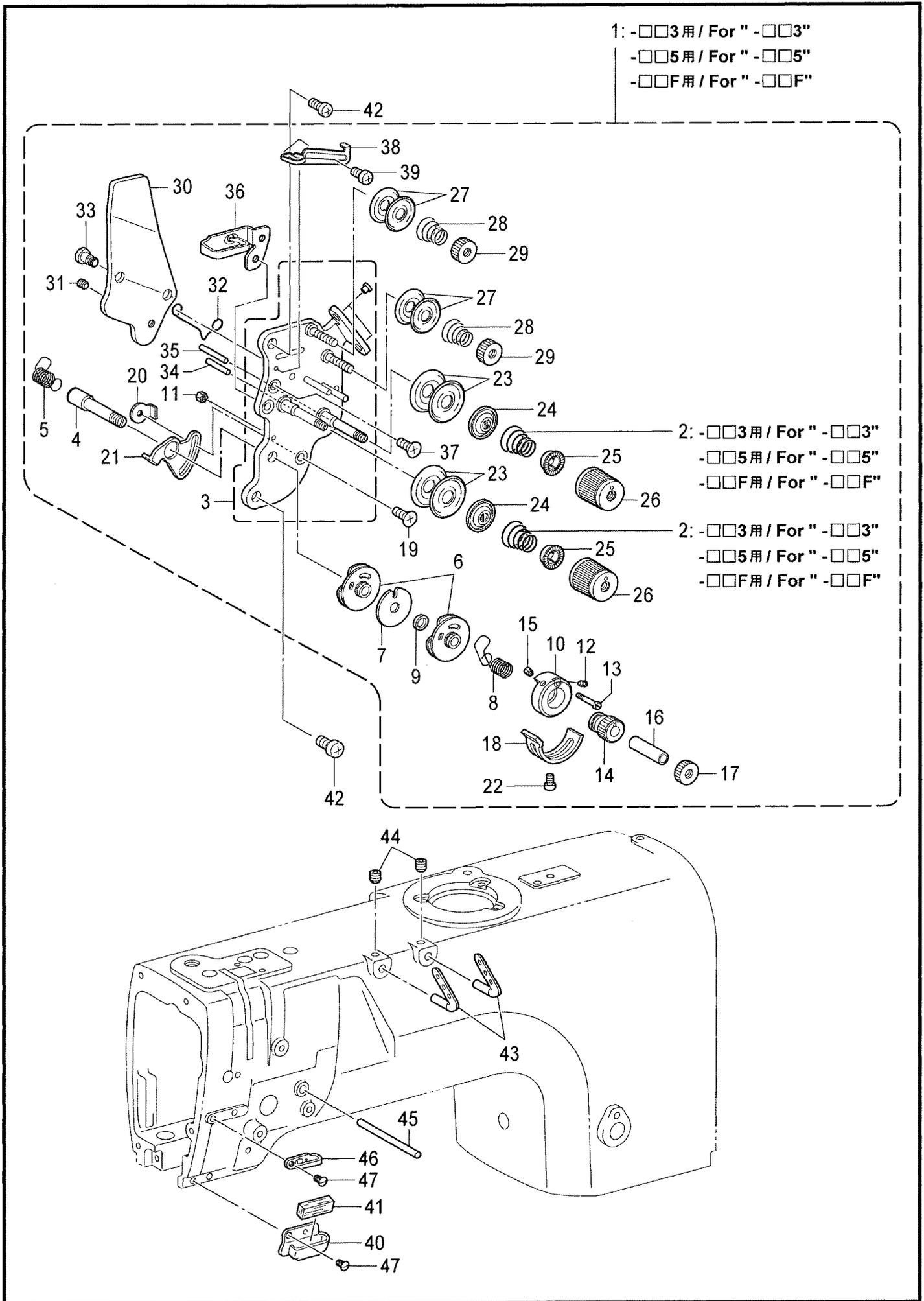

M. 糸通し関係 / Threading mechanism

REF.NO	CODE	Q'TY	品名	NAME OF PARTS	RM
1	SA3417001	1	<-□□3用> ウワイトチヨウシクミ-3	<For "-□□3"> UPPER THREAD TENSION ASSY, -3	
2	SA3415001	2	イトチヨウシバネL <-□□5用>	TENSION SPRING, L <For "-□□5">	
1	SA2607001	1	ウワイトチヨウシクミ-5	UPPER THREAD TENSION ASSY, -5	
2	SA3416001	2	イトチヨウシバネLL <-□□F用>	TENSION SPRING, LL <For "-□□F">	
1	SA2818001	1	ウワイトチヨウシクミ-1	UPPER THREAD TENSION ASSY, -1	
2	SA3414001	2	イトチヨウシバネM	TENSION SPRING, M	
3	SA4212001	1	イトチヨウシダイクミ	TENSION PLATE ASSY	
4	SA2613001	1	チヨウシジク	TENSION STUD	
5	SA2614001	1	イトトリバネL	THREAD TAKE-UP SPRING, L	
6	SA2615001	2	イトトリバネアンナイクミ	GUIDE ASSY, T/TAKE-UP SPRING	
7	SA2619001	1	スペーサー	SPACER	
8	SA2623001	1	イトトリバネR	THREAD TAKE-UP SPRING, R	
9	SA2620001	1	カラ-	COLLAR	
10	SA2621001	1	ストツパウケ	STOPPER SUPPORT	
11	021300106	1	1シュナット3	NUT 1 M3	
12	SA2626001	1	トメネジ3.5	SET SCREW, (CP) M3.5	
13	SA2624001	1	バネアンナイトメネジ	SPRING GUIDE SET SCREW	
14	SA2625001	1	チヨウセツツマミ	ADJUSTING THUMB	
15	SA2626001	1	トメネジ3.5	SET SCREW, (CP) M3.5	
16	SA2627001	1	カラ-	COLLAR	
17	SA2628001	1	イトチヨウシナット	TENSION NUT	
18	SA2629001	1	イトトリバネストツパ	STOPPER	
19	061350616	1	サラコ35X6	SCREW FLAT M3.5X6	
20	SA2824001	1	マワリドメナットM3.5	NUT, WHIRL-STOP M3.5	
21	SA2630001	1	イトトリバネストツパ	STOPPER	
22	062350512	1	ナベコ35X5	SCREW PAN M3.5X5	
23	145446001	4	イトチヨウシサラ	DISC, TENSION	
24	159805001	2	イトチヨウシサラオサエ	TENSION DISC PRESSER	
25	S20681000	2	チヨウシバネウエザガネ	WASHER	
26	S20682105	2	イトチヨウシナット	TENSION NUT	
27	144504001	4	イトアンナイサラ	THREAD GUIDE DISC	
28	154560001	2	プレテンションバネA	PRE-TENSION SPRING, A	
29	155510001	2	イトチヨウシナット	TENSION NUT	
30	SA2632001	1	イトユルメイタ	TENSION RELEASE PLATE	
31	012500536	1	アナヒラ5X5	SET SCREW SOCKET (FT) M5X5	
32	S38274001	1	イトユルメバネ	T-RELEASE SPRING	
33	SA2633001	2	ダンネジ3.5	SHOULDER SCREW, M3.5	
34	SA4506001	1	イトユルメピンL	TENSION RELEASE PIN, L	
35	SA4507001	1	イトユルメピンR	TENSION RELEASE PIN, R	
36	SA2634001	1	ア-ムイトアンナイU	THREAD GUIDE, U :ARM	
37	061350616	2	サラコ35X6	SCREW FLAT M3.5X6	
38	SA2635001	1	イトリヨウチヨウセイ	THREAD QUANTITY ADJUST	
39	062300616	1	ナベコ3X6	SCREW PAN M3X6	
40	SA2639001	1	ア-ムイトアンナイD	THREAD GUIDE, D :ARM	
41	114941001	1	ア-ムイトアンナイフェルト	FELT	
42	062500816	2	ナベコ5X8	SCREW PAN M5X8	
43	SA2636001	2	ミツメイトカケ	THREAD RETAINER	
44	012060636	2	アナヒラ6X6	SET SCREW SOCKET (FT) M6X6	
45	SA2637001	1	イトユルメジク	BAR, TENSION RELEASE	
46	SA2638001	1	ア-ムイトアンナイM	THREAD GUIDE, M :ARM	
47	SA2640001	2	サラネジ5X8	SCREW, FLAT M5X8	

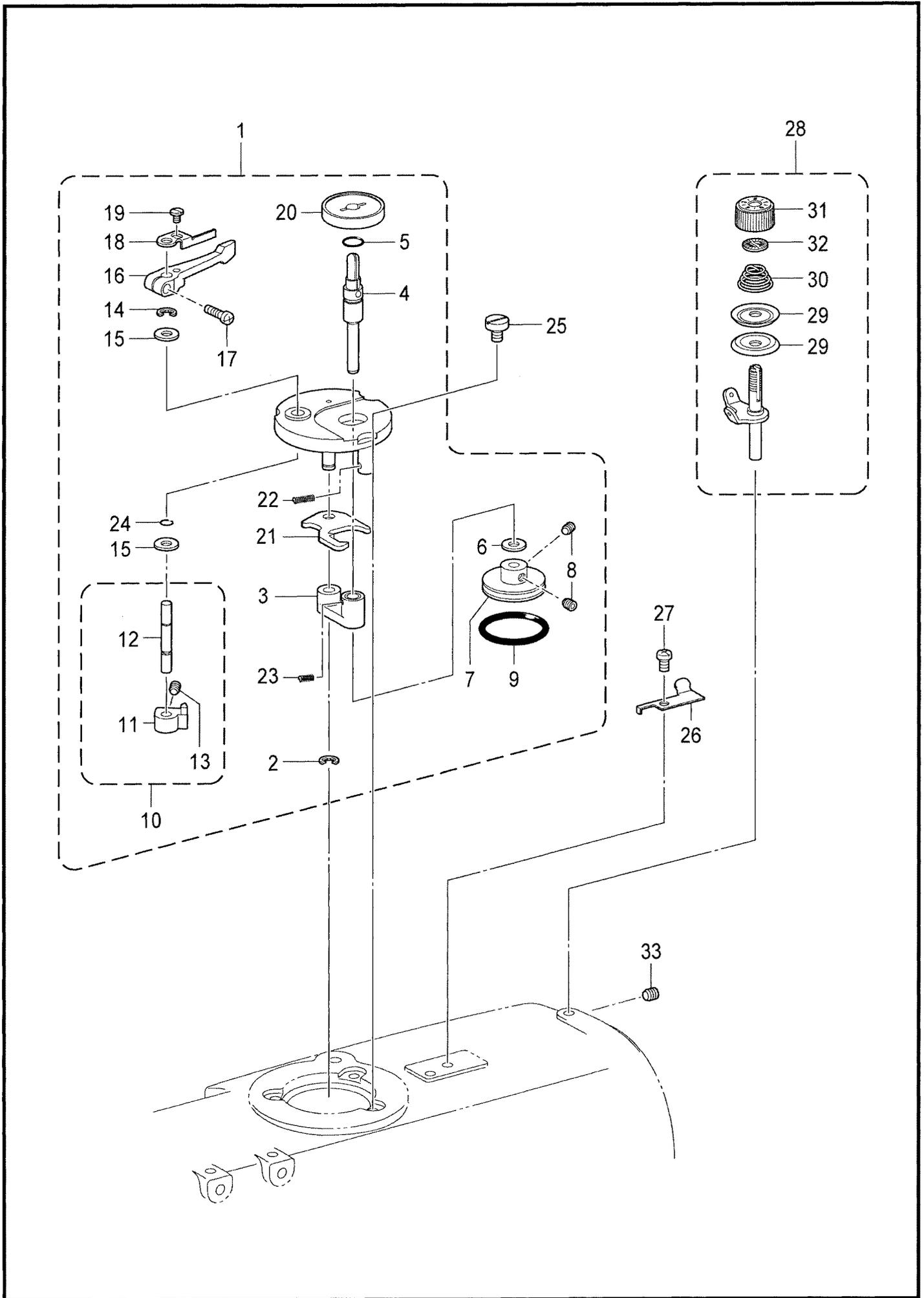

## N. 糸巻関係 / Bobbin winder mechanism

REF.NO	CODE	Q'TY	品名	NAME OF PARTS	RM
1	SA1971101	1	イトマキユニット	BOBBIN WINDER UNIT	
2	048040342	1	トメワE4	RETAINING RING E4	
3	SA1975001	1	イトマキジクウケクミ	B-WINDER SHAFT SUPPORT ASSY	
4	SA1978001	1	イトマキジク	BOBBIN WINDER SHAFT	
5	081009070	1	OリングP9	O RING P9	
6	025060136	1	ヒラザガネシヨウ6	WASHER PLAIN S 6	
7	SA1980001	1	イトマキクルマ	BOBBIN WINDER WHEEL	
8	012500536	2	アナヒラ5X5	SET SCREW SOCKET (FT) M5X5	
9	S25789000	1	ゴムフ29	RUBBER RING, 29	
10	SA1981101	1	ボビンオサエカムクミ	BOBBIN PRESSER CAM ASSY	
11	SA1982101	1	ボビンオサエカム	BOBBIN PRESSER CAM	
12	SA1983001	1	イトマキウデジク	BOBBIN WINDER ARM SHAFT	
13	012500536	1	アナヒラ5X5	SET SCREW SOCKET (FT) M5X5	
14	048040342	1	トメワE4	RETAINING RING E4	
15	025060136	2	ヒラザガネシヨウ6	WASHER PLAIN S 6	
16	SA1984001	1	ボビンオサエウデ	BOBBIN PRESSER ARM	
17	062401216	1	ナベコ4X12	SCREW PAN M4X12	
18	SA1985001	1	ボビンオサエ	BOBBIN PRESSER	
19	S23418002	1	シメネジ4X5	SCREW, M4X5	
20	SA1988001	1	ボビンウケ	BOBBIN SUPPORT	
21	SA1989001	1	イトマキレバー	BOBBIN WINDER LEVER	
22	SA1990101	1	モドシバネ	SPRING	
23	SA1991001	1	イトマキダイバネ	BOBBIN WINDER BASE SPRING	
24	SA2190001	1	OリングSS5	O RING, SS5	
25	SA1992101	3	イトマキコテイネジ	BOBBIN WINDER FIXED SCREW	
26	SA1360001	1	メス	KNIFE	
27	062500616	1	ナベコ5X6	SCREW PAN M5X6	
28	SA1994001	1	イトマキチヨウシクミ	BOBBIN WINDER TENSION ASSY	
29	145446001	2	イトチヨウシサラ	DISC, TENSION	
30	100401021	1	イトチヨウシバネ	TENSION SPRING	
31	S31032001	1	イトチヨウシナツト	TENSION NUT	
32	S12441001	1	チヨウシバネウエザガネ	WASHER	
33	012500536	1	アナヒラ5X5	SET SCREW SOCKET (FT) M5X5	

11: -□□3用 / For "-□□3"  
 -□□5用 / For "-□□5"  
 -□□F用 / For "-□□F"

10: -□□3用 / For "-□□3"  
 -□□5用 / For "-□□5"  
 -□□F用 / For "-□□F"

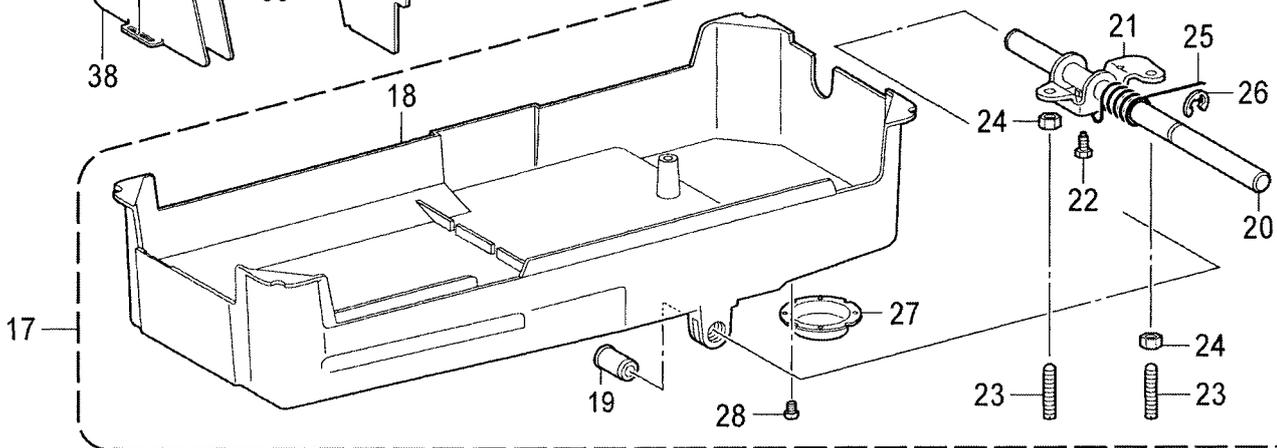
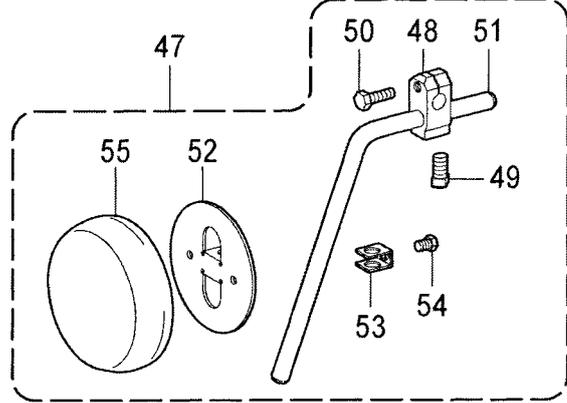
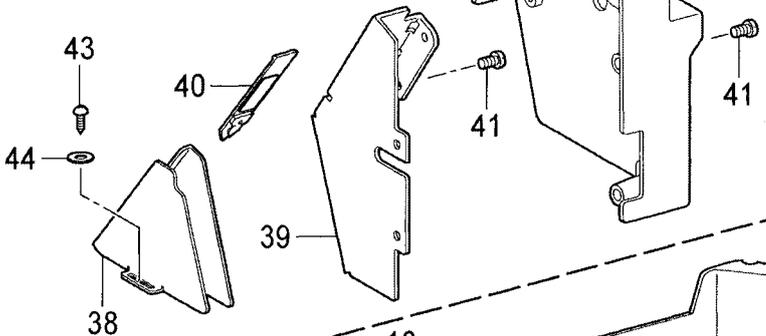
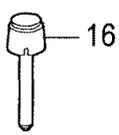
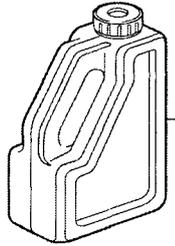
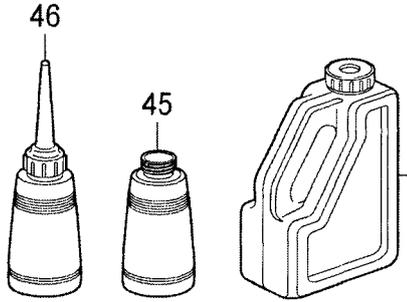
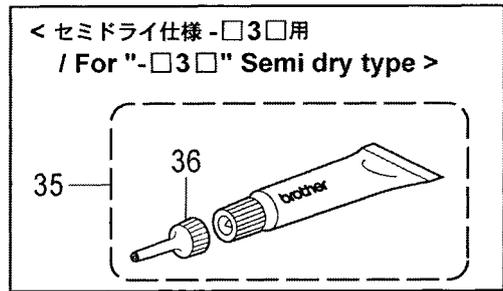
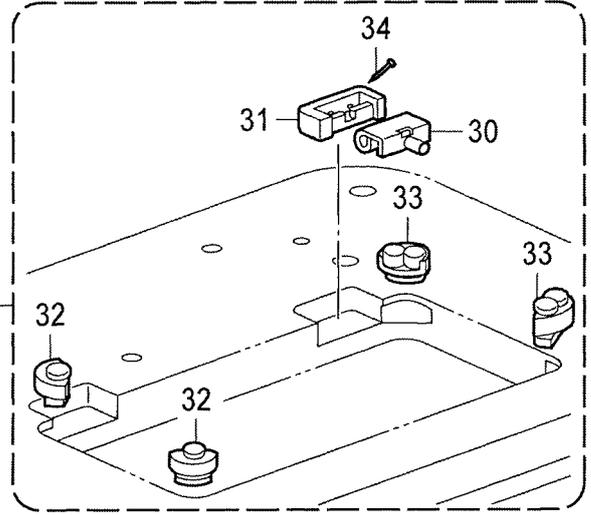
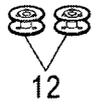
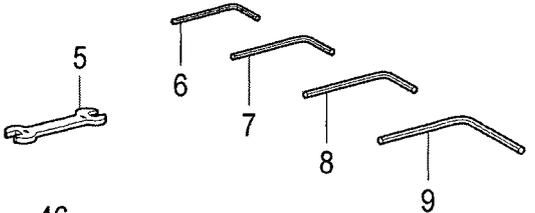
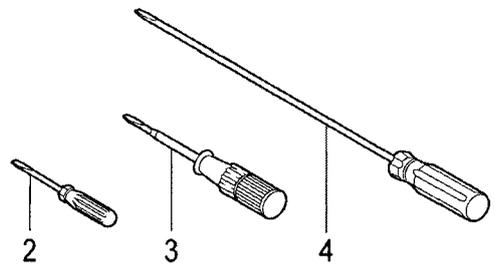
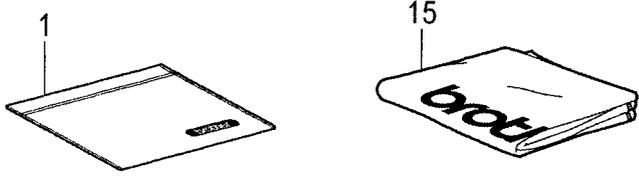

## Z1. 付属品関係 / Accessories

REF.NO	CODE	Q'TY	品名	NAME OF PARTS	RM
1	122991001	1	フゾクヒンポリフクロ	ACCESSORY BAG	
2	142443001	1	ネジマワシ1.9X52	SCREW-DRIVER, 1.9X52	
3	118837001	1	ネジマワシ3.4X70	SCREW-DRIVER, 3.4X70	
4	S17774001	1	ネジマワシ4.7X250	SCREW-DRIVER, 4.7X250	
5	100887001	1	スパナ8X9	WRENCH, 8X9	
6	142002001	1	6カクボウスパナ2	HEXAGONAL WRENCH, 2	
7	154125001	1	6カクボウスパナ2.5	HEXAGONAL WRENCH, 2.5	
8	142721001	1	6カクボウスパナ3	HEXAGONAL WRENCH, 3	
9	149570001	1	6カクボウスパナ5	HEXAGONAL WRENCH, 5	
			<-□□3用>	<For "-□□3">	
10	SA1752014	1	107415ハリ4コイリクミ	NEEDLE 4PIECE ASSY, 107415	
11	107415014	4	ミシンハリDPX5	NEEDLE, DPX5	
			<-□□5用>	<For "--□□5">	
10	SA1752022	1	107415ハリ4コイリクミ	NEEDLE 4PIECE ASSY, 107415	
11	107415022	4	ミシンハリDPX5	NEEDLE, DPX5	
			<-□□F用>	<For "-□□F">	
10	SA1752011	1	107415ハリ4コイリクミ	NEEDLE 4PIECE ASSY, 107415	
11	107415011	4	ミシンハリDPX5	NEEDLE, DPX5	
12	S01928151	2	ボビン	BOBBIN	
13	100477009	1	マクラ	HEAD REST	
14	S55663001	1	オイルタンククミ	OIL TANK ASSY	
15	144226001	1	トウブカバー	HEAD COVER	
16	145573000	1	ヒザアゲオシボウ	KNEE LIFTER COMPLYING BAR	
17	SA2691101	1	アブラウケクミ	OIL PAN ASSY	
18	SA2692101	1	アブラウケ	OIL PAN	
19	149578000	2	ヨコジクブツシュ	BUSH	
20	SA2582001	1	ヒザアゲヨコジク	KNEE LIFTER SHAFT	
21	SA2590001	1	ヒザアゲ	KNEE LIFTER	
22	S25344001	1	ボルト6	BOLT, M6	
23	S25475101	2	トメネジ6	SET SCREW, M6X19	
24	021060306	2	3シュナット6	NUT 3 M6	
25	S15889001	1	ヒザアゲネジリバネ	TWIST SPRING	
26	146293001	1	トメワE10	RETAINING RING, E10	
27	153230101	1	オイルニガシグチ	DRAIN	
28	S23418002	2	シメネジ4X5	SCREW, M4X5	
29	SA1969001	1	ラバーヒンジクミ	RUBBER HINGE ASSY	
30	143882001	2	トウブヒンジ	HEAD HINGE	
31	143910009	2	トウブヒンジウケゴム	RUBBER CUSHION	
32	SA1962001	2	トウブシキゴム	HEAD CUSHION	
33	SA1963001	2	トウブシキゴム	HEAD CUSHION	
34	109714000	4	クギ	NAIL	
			<セミドライ仕様 -□3□用>	<For "-□3□" semi dry type>	
35	SA2693001	1	グリスクミ	GREASE UNIT	
36	SA2695001	1	グリスノズル	GREASE NOZZLE	
37	SA2768101	1	ベルトカバー-U	BELT COVER, U	
38	SA2769001	1	ベルトカバー-D	BELT COVER, D	
39	SA2770101	1	ベルトカバー-ブラケット	BELT COVER BRACKET	
40	S37263001	1	ベルトカバー-DフタL	BELT COVER D LID, L	
41	062500816	4	ナベコ5X8	SCREW PAN M5X8	
42	062500816	2	ナベコ5X8	SCREW PAN M5X8	
43	100666002	2	マルモクネジ5.5X20	WOOD SCREW, ROUND M5.5X20	
44	025750132	2	ヒラザガネシヨウ5.56	WASHER PLAIN S SM5.56	
45	114486002	1	ポリオイラータイ	OILER	
46	114483002	1	ポリオイラークミ	OILER ASSY	
47	S38300001	1	ヒザアテクミ	KNEE LIFTER ASSY	
48	146039001	1	ヒザアテツギテ	KNEE LIFTER BRACKET	
49	100463001	1	4カクボルト7.94	BOLT, SQUARE SM7.94	
50	017762013	1	ボルト595-28X20	BOLT, SM5.95-28X20	
51	S38278001	1	ヒザアゲタテジク	KNEE LIFTER BAR	
52	S34756001	1	ヒザアテ	KNEE LIFTER PLATE	
53	114967001	1	ヒザアテストップパ	KNEE LIFTER PLATE STOPPER	
54	110087001	1	ボルト5.95	BOLT, SM5.95-28X8	
55	S31885001	1	ヒザアテカバー	KNEE LIFTER PLATE COVER	

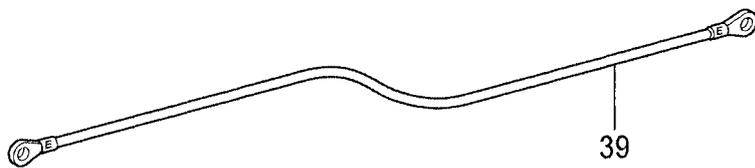
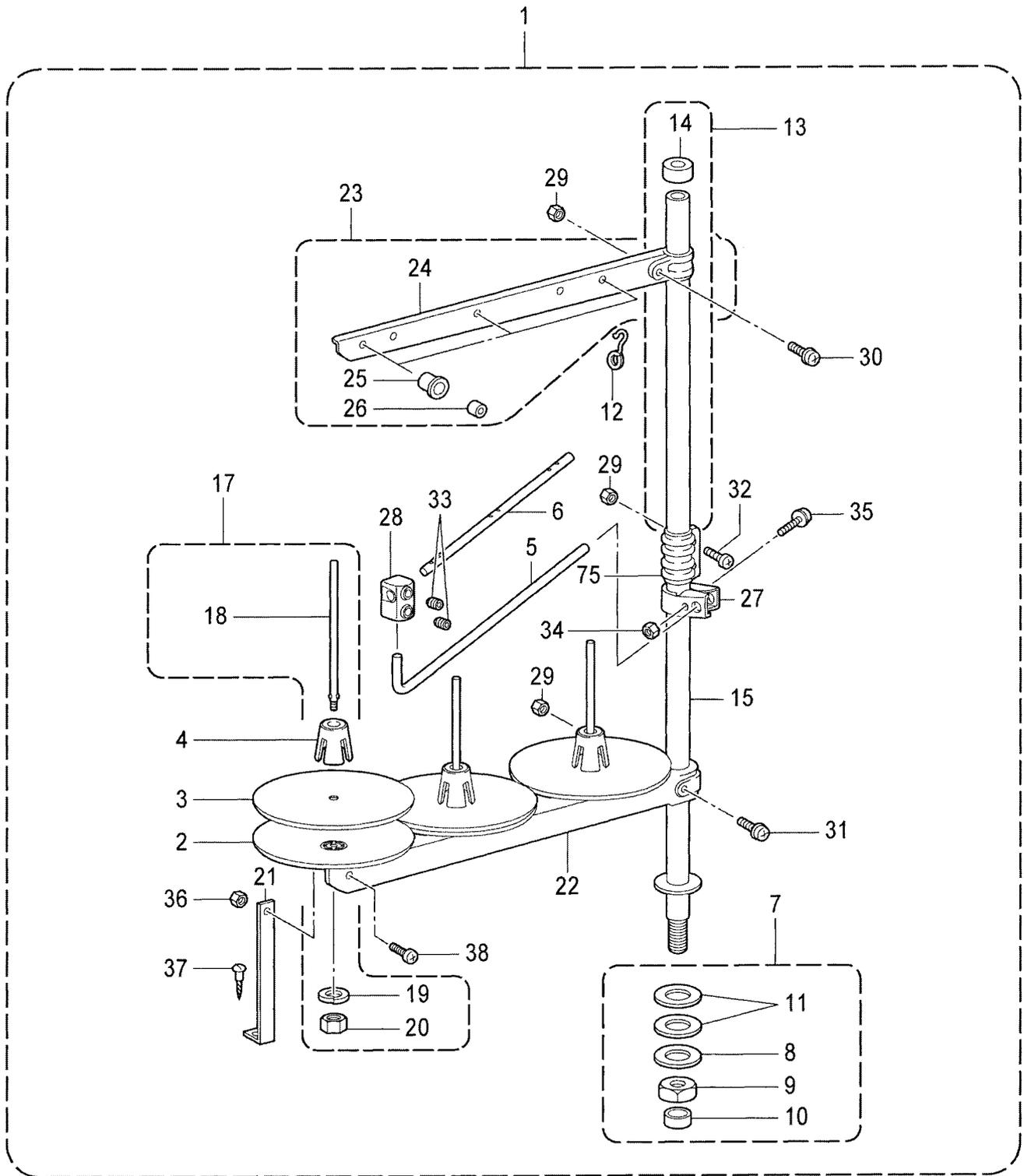

## Z2. 付属品関係 / Accessories

REF.NO	CODE	Q'TY	品名	NAME OF PARTS	RM
1	S07558309	1	イトタテダイクミ3DRTHF	COTTON STAND ASSY, 3DRTHF	
2	S51283001	3	ウケザラ	SPOOL STAND BASE	
3	150182000	3	スプールマット	SPOOL MAT	
4	S51282101	3	スプールクッション	SPOOL CUSHION	
5	S04109001	1	イトアンナイササエボウ	THREAD GUIDE SUPPORT BAR	
6	142997001	1	イトアンナイ3	THREAD GUIDE, 3	
7	SA2867001	1	パイプDネジセットB	PIPE D SCREW SET, B	
8	150206002	1	ヒラザガネ16	WASHER, PLAIN 16	
9	S38648001	1	6カクナットU5/8	NUT, U5/8-28	
10	150174000	1	コラムキャップ	COLUMN CAP	
11	S01005000	2	イトタテゴム	RUBBER WASHER	
12	S02747101	1	イトカケバネ	SPRING	
13	S40639001	1	コラムパイプキャップツキ	COLUMN PIPE W/CAP	
14	150174000	1	コラムキャップ	COLUMN CAP	
15	156112003	1	コラムパイプD	COLUMN PIPE, D	
16	150173003	1	コラムジョイント	COLUMN JOINT	
17	S21798001	3	スプールネジセット	SPOOL & SCREW SET	
18	150179002	3	スプールジクB	SPOOL SHAFT, B	
19	028050246	3	バネザガネ2-5	WASHER SPRING 2-5	
20	021500106	3	1シュナット5	NUT 1 M5	
21	150188009	1	スプールホルダー-ササエA	SPOOL HOLDER SUPPORT, A	
22	S02779009	1	スプールホルダー-3	SPOOL HOLDER, 3	
23	S02788009	1	スレツドハンガー-クミ3	THREAD HANGER ASSY, 3	
24	S02789009	1	スレツドハンガー-3	THREAD HANGER, 3	
25	150183000	3	イトカケハンガー-ダイ	THREAD HANGER BASE	
26	142990001	3	スレツドブツシュ	THREAD BUSH	
27	150185009	1	イトアンナイホルダー	THREAD GUIDE HOLDER	
28	138843001	1	ササエボウツギテ	JOINT	
29	021500106	4	1シュナット5	NUT 1 M5	
30	S37038001	1	ナベコヒラザ5X14	SCREW, PAN(S/P WASHER) M5X14	
31	S37037001	1	ナベコヒラザ5X32	SCREW, PAN (S/P WASHER) M5X32	
32	062501406	2	ナベコ5X14	SCREW PAN M5X14	
33	014060632	2	アナクボミ6X6	SET SCREW SOCKET (CP) M6X6	
34	021500106	1	1シュナット5	NUT 1 M5	
35	S37037001	1	ナベコヒラザ5X32	SCREW, PAN (S/P WASHER) M5X32	
36	021500106	1	1シュナット5	NUT 1 M5	
37	031452206	1	マルモク45X22	WOOD SCREW ROUND M4.5X22	
38	062501006	1	ナベコ5X10	SCREW PAN M5X10	
39	SA4313001	1	<セミドライ仕様 -□3□用> ア-スセン	<For "-□3□" semi dry type> GROUND WIRE	
40	062500816	1	ナベコ5X8	SCREW PAN M5X8	

Wa. 警告ラベル / Warning labels

警告ラベル / Warning labels	品名 / Name of parts	Size(mm)	Code
	<p>ラベル注意・和英 Label, caution Jpn / Eng</p>	<p>64 X 40</p>	<p>SA2040-001</p>
	<p>ラベル注意・中英 Label, caution Chn / Eng</p>	<p>64 X 40</p>	<p>SA2041-001</p>
	<p>アースマーク Label, grounding</p>	<p>φ 12</p>	<p>S37060-001</p>

T-8420B-Wa

## Sp.仕様別部品一覧表 / Different parts

### ■ かま / Rotary hooks

かまは下記のオプションパーツを用意しています。用途に合わせてご使用ください。  
(部品コードは、かまが箱に入った組コードです)

The following type of rotary hook are available. Select whichever one is suitable for your application.  
(The following parts codes are assigned for the rotary hooks in the boxes.)

#### ●標準 / Normal

	-□□F,-□□3用 / For -□□F, -□□3	-□□5用 / For -□□5
かま箱組 / Rotary hook assy	SA1668-111	SA1669-111
調子バネ / Tension spring	151145-001	151146-001
調子ネジ / Tension adjusting screw	151029-001	151029-001

#### ●オプション / Option

##### ○キャップ付 / Rotary hook with cap

	-□□F,-□□3用 / For -□□F, -□□3
かま箱組 / Rotary hook assy	SA1668-111
キャップ組 / Bobbin case assy	S07740-001
調子バネ / Tension spring	154518-001
調子ネジ / Tension adjusting screw	154519-001

##### ○オープン給油 / Extra lubrication rotary hook

かまへの油量が多いので、レース部の磨耗を防ぎます。厚物や極厚物の縫製に適しています。

Sufficient oil supplied to the rotary hook to prevent wear of the rotary hook race.

This type is suitable for sewing heavy and extra heavy materials.

	-□3□用 / For -□3□	-□5□用 / For -□5□
かま箱組 / Rotary hook assy	SA1671-111	SA1672-111
調子バネ / Tension spring	151145-001	151146001
調子ネジ / Tension adjusting screw	151029-001	151029-001

##### ○剣先強化 / Rotary hook with reinforced hook point

かまの剣先を強化し、剣先の磨耗を防ぎます。ループのできにくい素材(伸縮性のあるものなど)の縫製で、かまの剣先を針に接触させて使うような場合に適しています。

The rotary hook point is reinforced to improve its durability. This type is suitable for sewing materials that are hard to make loops on the surface ( like stretchy materials ), and that requires making contact with the hook point and the needles.

	-□□F,-□□3用 / For -□□F,-□□3
かま箱組 / Rotary hook assy	SA1673-011
調子バネ / Tension spring	151145-001
調子ネジ / Tension adjusting screw	151029-001

##### ○ORP釜 / RP rotary hook

油污れを解消したい場合に適しています。

Useful to prevent oil stains.

	-□□F,-□□3用 / For -□□F,-□□3
かま箱組 / Rotary hook assy	SA1674-002
内かま組 / Inner rotary hook assy	S36985-002
調子バネ / Tension spring	151145-001

## Ga. ゲージ部品一覧表 / Gauge parts List

### 標準品 / For normal

- \* 1-1/2 (38.1mm)より広いゲージを使用する場合は、ミシン本体等に特別な加工が必要です。  
なお、最大針幅 77mm まで出来ますので、納期・価格は別途相談して下さい。
- \* In case of using over 1-1/2 (38.1mm) gauge parts, it is required to make special machining on the arm-bed.  
A maximum stitch width specification of 77mm is available.  
Please consult your Brother representative concerning delivery date and price.

針幅 Needle gauge (mm)	針抱き組 Needle clamp assy	針板 Needle plate		送り歯 Feed dog (-3,-5) For medium & heavy materials	押え組 Presser foot assy
		中厚,厚物用(-3,5) 最大 5mm ピッチ For medium & heavy materials (Max 5mm pitch)	オプション 最大 4mm ピッチ Option (Max 4mm pitch)		
1/16 (1.6)	158808-001		142111-001	151078-001	151076-001
1/8 (3.2)	158794-101	117369-001	114950-001	114951-001	S36544-001
5/32 (4.0)	158796-101	150850-001	116503-001	116509-001	116502-001
3/16 (4.8)	158791-101	117133-001	112603-001	112659-001	SA4053-001
1/4 (6.4)	158792-101	117367-001	112604-001	112660-001	SA4049-001
5/16 (7.9)	158793-101	144882-001	112605-001	112661-001	112645-001
3/8 (9.5)	158798-101	144881-101	116506-101	116510-101	116498-001
7/16 (11.1)	158809-101		151596-001	151598-001	151597-101
1/2 (12.7)	158797-101	S09365-001	116505-001	116511-001	116499-101
5/8 (15.9)	158795-101	159577-001	116507-001	116512-001	116500-101
1 (25.4)	158805-101		147176-001	147178-001	147177-101
1-1/4 (31.8)	158799-001		116504-001	116508-001	116501-101
1-3/8 (34.9)	S10746-101	S14148-001		S14149-001	S10751-101
1-1/2 (38.1)	158800-101		118945-001	118947-001	118946-101
2 (50.8)	158802-101	144951-001		144947-001	144949-101
2-1/6 (55.0)	158803-101	147560-001		147561-001	147562-101
75mm	S16238-101		S16240-001	S16241-001	S16242-101
77mm	S30508-001		S30510-001	S30513-001	S30511-201

### ファンデーション用 / For foundation

- \* 針板と送り歯が標準品と異なります。針板取付用サラネジは 117160-001(H-5)を使用して下さい。
- \* The needle plate and the feed dog is different from normal parts.
- \* **Use part no. 117160-001(H-5) as the needle plate installation screw.**

針幅 Needle gauge (mm)	(針抱き組) Needle clamp assy	針板 Needle plate	送り歯 Feed dog	(押え組) Presser foot assy (Without finger guard)
1/8 (3.2) サン無し / Bar less	標準品 / Normal	S24571-001	S24572-001	標準品 / Normal
3/16 (4.8)		117158-001	117134-001	
1/4 (6.4)		117368-001	117365-001	
5/16 (7.9)		S31907-001	S31908-001	

### 空縫い用 / For sewing without material

- \* 針板と送り歯と押え組が標準品と異なります。最大送りピッチは 4mm 以下でご使用下さい。
- \* Needle plate, the feed dog and presser foot assembly is different from normal parts.
- \* **Use gauge components of for sewing without material which have a maximum feed pitch of 4mm or less.**

針幅 Needle gauge (mm)	(針抱き組) Needle clamp assy	針板 Needle plate	送り歯 Feed dog	押え組 Presser foot assy
3/16 (4.8)	標準品 / Normal	S36010-101	S36011-101	S36012-001
1/4 (6.4)		S36025-001	S36024-001	S36022-001

# Ga. ゲージ部品一覧表 / Gauge parts List

## 標準品 / For normal

針抱き組 Needle clamp assy	針板 Needle plate	
	中、厚物用(-3,-5) (最大5mmピッチ) For medium & heavy materials (Max 5mm pitch)	オプション (最大4mmピッチ) Option (Max 4mm pitch)
送り歯 Feed dog 中厚, 厚物用(-3, -5) For medium & heavy materials	押え組 Presser foot assy	

## ファンデーション用 / For foundation

針板 Needle plate	送り歯 Feed dog

## 空縫い用 / For sewing without material

針板 Needle plate	送り歯 Feed dog	押え組 Presser foot assy

## Ga. ゲージ部品一覧表 / Gauge parts List

### 薄物用 / For light materials

\* 送り歯が標準品と異なります。

\* The feed dog is different from normal parts.

針幅 Needle gauge (mm)	(針抱き組) Needle clamp assy	(針板) Needle plate	送り歯 Feed dog	(押え組) Presser foot assy
1/8 (3.2)	標準品 / Normal	標準品 / Normal	S07880-001	標準品 / Normal
3/16 (4.8)			S07878-001	
1/4 (6.4)			S07879-001	

### 厚物用 / For heavy materials

\* 送り歯が標準品と異なります。

\* The feed dog is different from normal parts.

針幅 Needle gauge (mm)	(針抱き組) Needle clamp assy	(針板) Needle plate	送り歯 Feed dog	(押え組) Presser foot assy
3/16 (4.8)	標準品 / Normal	標準品 / Normal	S21149-001	標準品 / Normal
1/4 (6.4)			S21150-001	

### 極厚物用 / For extra heavy materials

\* 送り歯が標準品と異なります。

\* The feed dog is different from normal parts.

針幅 Needle gauge (mm)	(針抱き組) Needle clamp assy	(針板) Needle plate	送り歯 Feed dog	(押え組) Presser foot assy
1/8 (3.2)	標準品 / Normal	標準品 / Normal	158430-001	標準品 / Normal
3/16 (4.8)			S13588-001	
1/4 (6.4)			153882-001	
3/8 (9.5)			153887-001	
1/2 (12.7)			153892-001	
5/8 (15.9)			153897-001	

### 極薄物用 / For extra light materials

\* 送り歯と押え組が標準品と異なります。

\* 押え組の形状は標準品と同じですが、特殊な表面処理が施してあります。

\* The feed dog and presser foot assembly is different from normal parts.

\* The shape of the presser foot assembly is the same as for the standard part, but it has a special surface processing.

針幅 Needle gauge (mm)	(針抱き組) Needle clamp assy	(針板) Needle plate	送り歯 Feed dog	押え組 Presser foot assy
3/16 (4.8)	標準品 / Normal	標準品 / Normal	S36832-001	S36833-001
1/4 (6.4)			S36829-001	S36830-001

## Ga . ゲージ部品一覧表 / Gauge parts List

### オプション部品 / Option parts

\* 押え組が標準品と異なります。案内付押えは、最大送りピッチ 4mm 以下でご使用下さい。

\* The presser foot assembly is different from normal parts.

\* The presser foot assembly with guide should be used with a maximum feed pitch of 4mm or less.

品名 Name of parts	針幅 Needle gauge (mm)	(針抱き組) Needle clamp assy	(針板) Needle plate	(送り歯) Feed dog	押え組 Presser foot assy
案内付き押え組 Presser foot assy with guide	1/8 (3.2)	標準品 / Normal	標準品 / Normal	標準品 / Normal	149311-001
	3/16 (4.8)				117281-001
	1/4 (6.4)				149312-001
左案内付き押え Presser foot assy with guide, L	5/16 (7.9)				S13735-001
ファスナー付け用 Presser foot assy for attach zipper (Right)	1/8 (3.2)				S14080-001
左ファスナー付け用 Presser foot assy for attach zipper (Left)	1/8 (3.2)	S33459-001			

# Ga. ゲージ部品一覧表 / Gauge parts List

## 薄物用 / For light materials

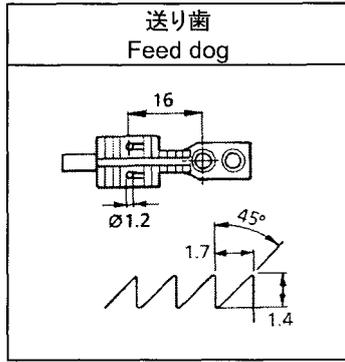

## 厚物用 / For heavy materials

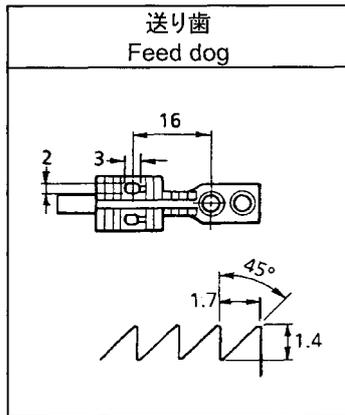

## 極厚物用 / For extra heavy materials

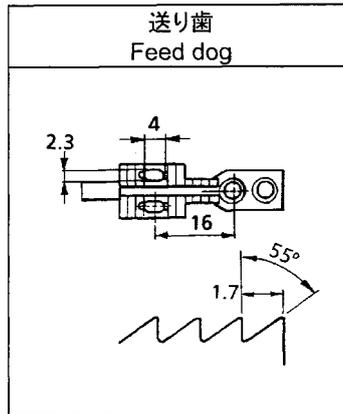

## 極薄物用 / For extra light materials

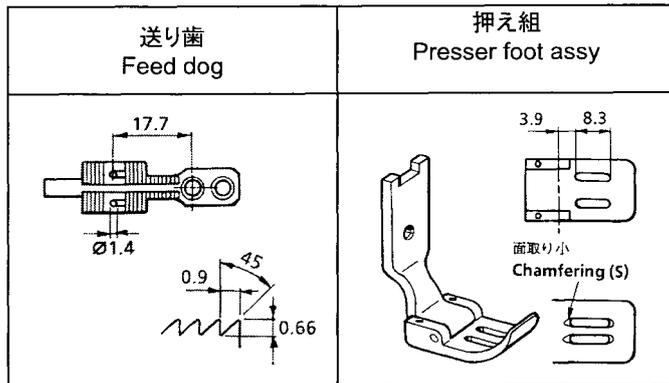

## オプション部品 / Option parts

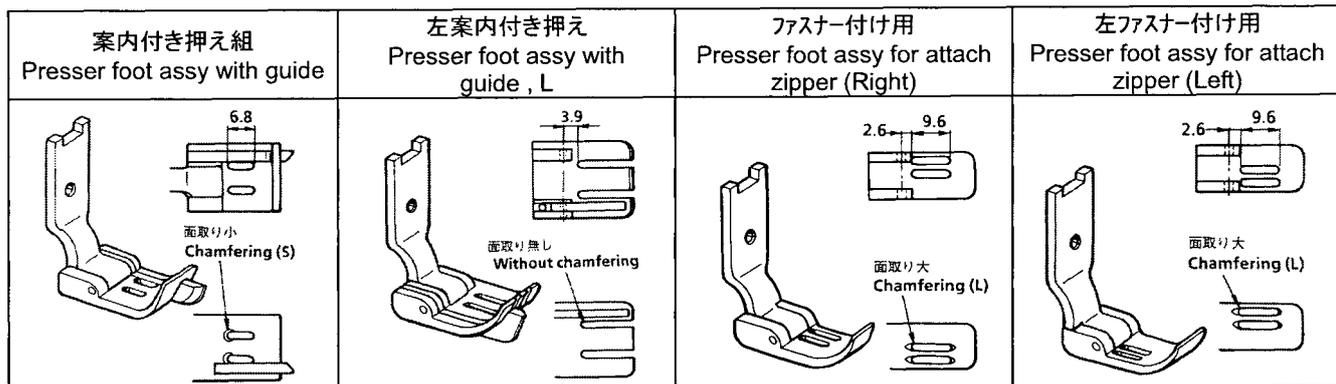

# Ga. ゲージ部品一覧表 / Gauge parts List

## 下送り用 / For drop Feed

\*1-1/2" (38.1 mm)より広いゲージを使用する場合は、ミシン本体等に特別な加工が必要です。

なお、最大針幅 77 mm まで出来ますので、納期・価格は別途相談して下さい。

\*In case of using over 1-1/2" (38.1 mm) gauge parts, it is necessary to make special machining on the arm-bed.

The specification with a maximum stitch width of 77 mm is available.

Please consult your Brother representative concerning delivery date and price.

針幅 Needle gauge (inch) (mm)	針抱き組 Needle clamp assy	針板 Needle plate		送り歯 Feed dog		押え組 Presser foot assy	
		薄物用 (-1) For light materials	極薄物用 For extra light materials	薄物用 (-1) For light materials	極薄物用 For extra light materials	薄物用 (-1) For light materials	極薄物用 For extra light materials
1/8 (3.2)	158794-101	S07686-001		S07696-001		S38544-001	
3/16 (4.8)	158791-101	S07688-001	S36842-001	S07698-001	S36838-001	S38542-001	S36839-001
1/4 (6.4)	158792-101	S07689-001	S36841-001	S07699-001	S36835-001	S38543-001	S36836-001
1/2 (12.7)	158797-101	S07693-001		S07703-001		S07684-101	
3/4 (19.1)	158806-101	S07996-001		S07998-001		S07889-101	
	20mm S00937-001	S13479-001		S07998-001		S13480-101	
7/8 (22.2)	158807-101	S07997-001	S37011-001	S07999-001	S07999-001	S07894-101	S37012-001

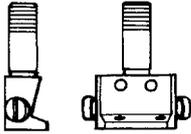
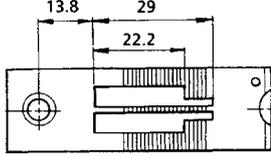
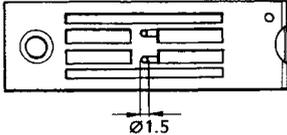
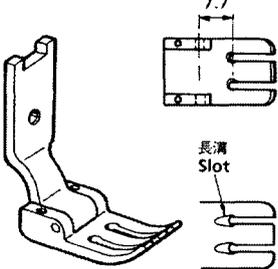
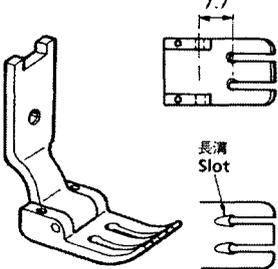
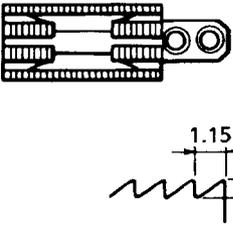
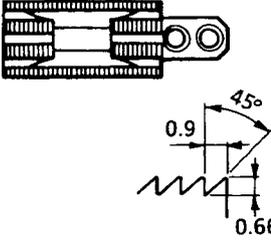
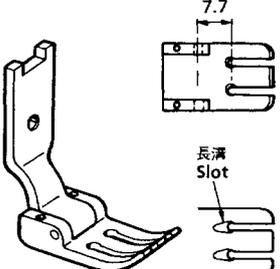
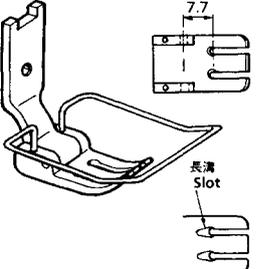
針抱き組 Needle clamp assy	針板 Needle plate		押え組 Presser foot assy	
	薄物用 (-1) For light materials	極薄物用 For extra light materials	薄物用 (-1) For light materials	極薄物用 For extra light materials
				
送り歯 Feed dog		押え組 Presser foot assy		
薄物用 (-1) For light materials	極薄物用 For extra light materials	薄物用 (-1) For light materials		
				

# Ga. ゲージ部品一覧表 / Gauge parts List

## 前立て用 / For shirt fronts

針幅 Needle gauge mm	針抱き組 Needle clamp assy	針板 Needle plate	送り歯 Feed dog	押え組 Presser foot assy
		薄物用 (-1) For light materials	薄物用 (-1) For light materials	薄物用 (-1) For light materials
18mm	S14352-001	S14354-001	S14357-001	S14355-101
20mm	S00937-001	S13479-001	S14360-001	S14358-101
22mm	158807-001	S07997-001	S14363-001	S14361-101
24mm	S14364-001	S14366-001	S14369-001	S14367-101
26mm	S14370-001	S14372-001	S14375-001	S14373-101
28mm	S14376-001	S14378-001	S14381-001	S14379-101
30mm	S16651-001	S16653-001	S16656-001	S16654-101

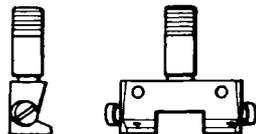
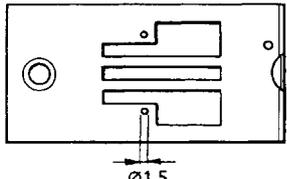
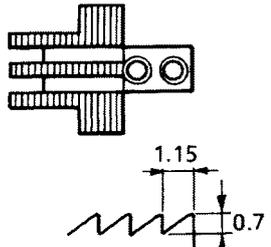
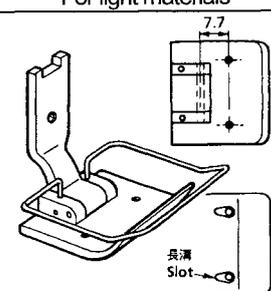
針抱き組 Needle clamp assy	針板 Needle plate	送り歯 Feed dog	押え組 Presser foot assy
	薄物用 (-1) For light materials	薄物用 (-1) For light materials	薄物用 (-1) For light materials
	 <p>Ø1.5</p>	 <p>1.15 0.7</p>	 <p>7.7 長溝 Slot</p>

CODE	REF.NO	Page	CODE	REF.NO	Page	CODE	REF.NO	Page	CODE	REF.NO	Page
012060636	C -39	6	062300416	F -24	12	104450101	L -42	22	129458102	E -23	10
	E -33	10	062300612	G1 -19	14		L -58	22	138843001	Z2 -28	32
	F -7	12		G1 -19	16	104821001	E -45	10	140063001	A -1	2
	F -27	12	062300616	M -39	26	107415011	Z1 -11	30	140890009	L -63	24
	K -16	20	062350512	M -22	26	107415014	Z1 -11	30	141208001	D -5	8
	M -44	26	062350816	C -7	6	107415022	Z1 -11	30	142002001	Z1 -6	30
012061036	B -28	4	062400416	G1 -54	16	108549001	E -24	10	142111001	Ga	35
	B -32	4	062400616	F -19	12	108801001	L -56	22	142274101	L -34	22
012061832	D -14	8		F -34	12	108802001	F -5	12	142443001	Z1 -2	30
012500536	B -20	4		G1 -27	14		L -55	22	142721001	Z1 -8	30
	D -22	8		G1 -27	16	109714000	Z1 -34	30	142746002	E -22	10
	G1 -15	14		G1 -29	14	110087001	Z1 -54	30	142990001	Z2 -26	32
	M -31	26		G1 -29	16	112603001	Ga	35	142997001	Z2 -6	32
	N -8	28		G1 -32	14	112604001	Ga	35	143611201	E -8	10
	N -13	28		G1 -32	16	112605001	Ga	35	143612100	E -9	10
	N -33	28		L -62	24	112645001	Ga	35	143613051	E -16	10
014060632	Z2 -33	32	062401016	C -4	6	112659001	Ga	35	143616001	E -17	10
014500836	B -17	4	062401216	N -17	28	112660001	Ga	35	143882001	Z1 -30	30
016061031	E -30	10	062401616	L -51	22	112661001	Ga	35	143910009	Z1 -31	30
017762013	Z1 -50	30	062500616	A -9	2	112728001	C -8	6	144226001	Z1 -15	30
018062032	C -34	6		C -16	6	112753001	L -64	24	144504001	M -27	26
	C -44	6		F -40	12	113014000	B -7	4	144881101	Ga	35
	E -15	10		L -54	22	113050001	H -7	18	144882001	Ga	35
018062532	C -41	6		N -27	28	114483002	Z1 -46	30	144947001	Ga	35
018081236	L -3	22	062500816	A -5	2	114486002	Z1 -45	30	144949101	Ga	35
021060306	D -15	8		B -34	4	114941001	M -41	26	144951001	Ga	35
	D -32	8		B -39	4	114950001	Ga	35	145446001	M -23	26
	Z1 -24	30		C -24	6	114951001	Ga	35		N -29	28
021300106	M -11	26		C -31	6	114967001	Z1 -53	30	145573000	Z1 -16	30
021350106	F -16	12		D -2	8	115947001	G1 -42	16	146039001	Z1 -48	30
021500106	D -25	8		E -46	10	116010001	A -18	2	146293001	Z1 -26	30
	E -54	10		F -39	12	116323001	H -2	18	147176001	Ga	35
	Z2 -20	32		L -7	22	116498001	Ga	35	147177101	Ga	35
	Z2 -29	32		M -42	26	116499101	Ga	35	147178001	Ga	35
	Z2 -34	32		Z1 -41	30	116500101	Ga	35	147560001	Ga	35
	Z2 -36	32		Z1 -42	30	116501101	Ga	35	147561001	Ga	35
021500316	G1 -12	14		Z2 -40	32	116502001	Ga	35	147562101	Ga	35
025030132	F -23	12	062501006	Z2 -38	32	116503001	Ga	35	148394000	C -14	6
025050236	E -49	10	062501016	E -3	10	116504001	Ga	35	148743001	L -33	22
025050336	E -44	10	062501216	A -7	2	116505001	Ga	35	149311001	Ga	38
025060132	F -14	12		E -43	10	116506101	Ga	35	149312001	Ga	38
025060136	G1 -49	16		E -48	10	116507001	Ga	35	149570001	Z1 -9	30
	N -6	28		E -53	10	116508001	Ga	35	149578000	Z1 -19	30
	N -15	28	062501406	Z2 -32	32	116509001	Ga	35	150173003	Z2 -16	32
025060236	L -66	24	062501416	D -24	8	116510101	Ga	35	150174000	Z2 -10	32
025100132	E -37	10	072600480	J -9	20	116511001	Ga	35		Z2 -14	32
025710132	G1 -11	14	076023800	B -24	4	116512001	Ga	35	150179002	Z2 -18	32
025750132	Z1 -44	30	081004070	L -24	22	117133001	Ga	35	150182000	Z2 -3	32
028050246	Z2 -19	32		L -28	22	117134001	Ga	35	150183000	Z2 -25	32
031452206	Z2 -37	32	081009070	N -5	28	117158001	Ga	35	150185009	Z2 -27	32
037300816	K -4	20	081038070	L -18	22	117160001	H -5	18	150188009	Z2 -21	32
048040342	N -2	28	0A4400806	K -12	20	117281001	Ga	38	150206002	Z2 -8	32
	N -14	28		L -43	22	117365001	Ga	35	150850001	Ga	35
048060342	E -18	10	0A4402506	K -14	20	117367001	Ga	35	151027001	G2 -5	18
048080342	E -36	10	0A5501006	L -21	22	117368001	Ga	35	151029001	Sp	34
061350616	M -19	26	100032004	H -5	18	117369001	Ga	35	151030001	G2 -4	18
	M -37	26	100328001	E -26	10	118735002	C -35	6	151076001	Ga	35
062060816	E -7	10	100401021	N -30	28	118837001	Z1 -3	30	151078001	Ga	35
	E -52	10	100463001	Z1 -49	30	118945001	Ga	35	151145001	Sp	34
	L -46	22	100477009	Z1 -13	30	118946101	Ga	35	151146001	Sp	34
062061016	G1 -48	16	100666002	Z1 -43	30	118947001	Ga	35	151596001	Ga	35
	L -65	24	100887001	Z1 -5	30	118954000	E -10	10	151597101	Ga	35
	C -32	6	104450101	L -17	22	122991001	Z1 -1	30	151598001	Ga	35

## 索引 / INDEX

CODE	REF.NO	Page	CODE	REF.NO	Page	CODE	REF.NO	Page	CODE	REF.NO	Page
153230101	Z1 -27	30	S05246000	L -32	22	S14372001	Ga	41	S36829001	Ga	37
153882001	Ga	37	S07346101	D -6	8	S14373101	Ga	41	S36830001	Ga	37
153887001	Ga	37	S07349001	D -20	8	S14375001	Ga	41	S36832001	Ga	37
153892001	Ga	37	S07350001	D -33	8	S14376001	Ga	41	S36833001	Ga	37
153897001	Ga	37	S07353001	D -13	8	S14378001	Ga	41	S36835001	Ga	40
154125001	Z1 -7	30	S07355051	D -23	8	S14379101	Ga	41	S36836001	Ga	40
154518001	Sp	34	S07374109	E -39	10	S14381001	Ga	41	S36838001	Ga	40
154519001	Sp	34	S07376001	E -50	10	S15889001	Z1 -25	30	S36839001	Ga	40
154560001	M -28	26	S07419001	G1 -6	14	S16196001	D -6	8	S36841001	Ga	40
154965001	G1 -17	14	S07420000	G1 -5	14	S16238101	Ga	35	S36842001	Ga	40
	G1 -17	16	S07465000	C -18	6	S16240001	Ga	35	S36985002	Sp	34
155510001	M -29	26	S07494001	H -9	18	S16241001	Ga	35	S37011001	Ga	40
156112003	Z2 -15	32	S07558309	Z2 -1	32	S16242101	Ga	35	S37012001	Ga	40
158115001	B -27	4	S07684101	Ga	40	S16651001	Ga	41	S37037001	Z2 -31	32
	J -13	20	S07686001	Ga	40	S16653001	Ga	41		Z2 -35	32
158430001	Ga	37	S07688001	Ga	40	S16654101	Ga	41	S37038001	Z2 -30	32
158791101	Ga	35	S07689001	Ga	40	S16656001	Ga	41	S37060001	A -21	2
	Ga	40	S07693001	Ga	40	S17774001	Z1 -4	30		Wa	33
158792101	Ga	35	S07696001	Ga	40	S20681000	M -25	26	S37263001	Z1 -40	30
	Ga	40	S07698001	Ga	40	S20682105	M -26	26	S38212001	G1 -16	14
158793101	Ga	35	S07699001	Ga	40	S21149001	Ga	37		G1 -16	16
158794101	Ga	35	S07703001	Ga	40	S21150001	Ga	37	S38266000	L -9	22
	Ga	40	S07740001	Sp	34	S21798001	Z2 -17	32	S38274001	M -32	26
158795101	Ga	35	S07746001	G2 -6	18	S23418002	N -19	28	S38278001	Z1 -51	30
158796101	Ga	35	S07878001	Ga	37		Z1 -28	30	S38300001	Z1 -47	30
158797101	Ga	35	S07879001	Ga	37	S23460001	C -37	6	S38398001	B -5	4
	Ga	40	S07880001	Ga	37	S23651001	B -10	4	S38422001	E -19	10
158798101	Ga	35	S07889101	Ga	40		B -25	4	S38427001	E -20	10
158799001	Ga	35	S07894101	Ga	40		F -9	12	S38481000	J -2	20
158800101	Ga	35	S07996001	Ga	40	S24571001	Ga	35		J -4	20
158802101	Ga	35	S07997001	Ga	40	S24572001	Ga	35	S38542001	Ga	40
158803101	Ga	35		Ga	41	S25234001	B -3	4	S38543001	Ga	40
158805101	Ga	35	S07998001	Ga	40	S25235001	B -11	4	S38544001	Ga	40
158806101	Ga	40	S07999001	Ga	40	S25236001	B -12	4	S38648001	Z2 -9	32
158807001	Ga	41	S09260001	G1 -4	14		E -13	10	S38707001	B -4	4
158807101	Ga	40	S09261001	G1 -4	14		J -11	20	S39051001	D -12	8
158808001	Ga	35	S09365001	Ga	35	S25260001	B -8	4	S39830101	E -28	10
158809101	Ga	35	S10746101	Ga	35		C -21	6	S40639001	Z2 -13	32
159577001	Ga	35	S10751101	Ga	35		C -28	6	S48367000	E -42	10
159805001	M -24	26	S11244001	H -4	18	S25289001	D -9	8	S50098101	E -25	10
228475000	L -12	22	S12441001	N -32	28	S25344001	Z1 -22	30	S51282101	Z2 -4	32
J04273001	K -8	20	S13160001	B -15	4	S25475101	Z1 -23	30	S51283001	Z2 -2	32
J04310001	K -9	20	S13479001	Ga	40	S25789000	N -9	28	S51815001	L -2	22
J04311001	K -15	20		Ga	41	S30508001	Ga	35		L -15	22
J04338001	K -13	20	S13480101	Ga	40	S30510001	Ga	35	S55663001	Z1 -14	30
J04339001	K -11	20	S13588001	Ga	37	S30511201	Ga	35	S58900000	G1 -53	16
J04340001	K -10	20	S13735001	Ga	38	S30513001	Ga	35	SA1120001	B -9	4
J04352001	K -1	20	S14080001	Ga	38	S31006001	D -11	8	SA1174001	D -3	8
J04353001	K -2	20	S14148001	Ga	35	S31032001	N -31	28	SA1175001	D -4	8
J04354001	K -6	20	S14149001	Ga	35	S31885001	Z1 -55	30	SA1179001	D -19	8
J04355001	K -5	20	S14352001	Ga	41	S31907001	Ga	35		D -28	8
J04356001	K -7	20	S14354001	Ga	41	S31908001	Ga	35		D -30	8
J04357001	K -3	20	S14355101	Ga	41	S33459001	Ga	38	SA1360001	N -26	28
S00937001	Ga	40	S14357001	Ga	41	S34438051	A -17	2	SA1668111	Sp	34
	Ga	41	S14358101	Ga	41	S34756001	Z1 -52	30	SA1669111	Sp	34
S01005000	Z2 -11	32	S14360001	Ga	41	S36010101	Ga	35	SA1671111	Sp	34
S01928151	G1 -50	16	S14361101	Ga	41	S36011101	Ga	35	SA1672111	Sp	34
	Z1 -12	30	S14363001	Ga	41	S36012001	Ga	35	SA1673011	Sp	34
S02747101	Z2 -12	32	S14364001	Ga	41	S36022001	Ga	35	SA1674002	Sp	34
S02779009	Z2 -22	32	S14366001	Ga	41	S36024001	Ga	35	SA1752011	Z1 -10	30
S02788009	Z2 -23	32	S14367101	Ga	41	S36025001	Ga	35	SA1752014	Z1 -10	30
S02789009	Z2 -24	32	S14369001	Ga	41	S36544001	Ga	35	SA1752022	Z1 -10	30
S04109001	Z2 -5	32	S14370001	Ga	41	S36663051	A -16	2	SA1962001	Z1 -32	30

CODE	REF.NO	Page	CODE	REF.NO	Page	CODE	REF.NO	Page	CODE	REF.NO	Page
SA1963001	Z1 -33	30	SA2515001	E -5	10	SA2615001	M -6	26	SA2957001	L -6	22
SA1969001	Z1 -29	30	SA2516001	E -6	10	SA2619001	M -7	26	SA2958001	B -19	4
SA1971101	N -1	28	SA2518001	E -11	10	SA2620001	M -9	26	SA3037001	L -35	22
SA1975001	N -3	28	SA2521001	E -14	10	SA2621001	M -10	26	SA3040001	L -36	22
SA1978001	N -4	28	SA2523001	E -27	10	SA2623001	M -8	26	SA3044001	L -47	22
SA1980001	N -7	28	SA2525001	E -29	10	SA2624001	M -13	26	SA3045101	L -44	22
SA1981101	N -10	28	SA2526001	E -31	10	SA2625001	M -14	26	SA3046001	L -45	22
SA1982101	N -11	28	SA2527001	E -32	10	SA2626001	M -12	26	SA3047001	L -49	22
SA1983001	N -12	28	SA2528101	E -34	10		M -15	26	SA3048101	L -59	22
SA1984001	N -16	28	SA2529101	E -35	10	SA2627001	M -16	26	SA3049001	L -60	24
SA1985001	N -18	28	SA2530001	E -38	10	SA2628001	M -17	26	SA3054001	G1 -25	14
SA1988001	N -20	28	SA2531001	E -40	10	SA2629001	M -18	26	SA3055101	L -48	22
SA1989001	N -21	28	SA2532001	E -47	10	SA2630001	M -21	26	SA3056001	E -21	10
SA1990101	N -22	28	SA2533001	E -51	10	SA2632001	M -30	26	SA3057001	B -35	4
SA1991001	N -23	28	SA2543001	F -4	12	SA2633001	M -33	26	SA3058101	B -36	4
SA1992101	N -25	28	SA2544001	F -6	12	SA2634001	M -36	26	SA3059001	B -38	4
SA1994001	N -28	28	SA2546001	F -8	12	SA2635001	M -38	26	SA3060001	L -37	22
SA2040001	A -22	2	SA2550001	F -25	12	SA2636001	M -43	26	SA3061001	L -30	22
	Wa	33	SA2551001	F -26	12	SA2637001	M -45	26	SA3062001	E -1	10
SA2041001	A -22	2	SA2552001	F -38	12	SA2638001	M -46	26	SA3065001	B -37	4
	Wa	33	SA2553001	F -17	12	SA2639001	M -40	26	SA3067001	E -41	10
SA2165001	D -29	8	SA2554001	F -18	12	SA2640001	M -47	26	SA3147001	L -25	22
SA2190001	N -24	28	SA2555001	F -28	12	SA2691101	Z1 -17	30		L -29	22
SA2440001	A -3	2	SA2556001	G1 -41	16	SA2692101	Z1 -18	30		L -38	22
SA2441001	A -6	2		G1 -45	16	SA2693001	Z1 -35	30	SA3414001	M -2	26
SA2443001	A -8	2	SA2557001	G1 -7	14	SA2695001	Z1 -36	30	SA3415001	M -2	26
SA2444001	A -10	2	SA2558001	G1 -52	16	SA2720001	B -29	4	SA3416001	M -2	26
SA2445001	A -11	2	SA2560001	G1 -10	14	SA2722001	G1 -43	16	SA3417001	M -1	26
SA2447001	A -12	2	SA2562101	G1 -18	14	SA2723001	L -19	22	SA3710001	C -6	6
SA2449001	A -14	2	SA2563101	G1 -34	16	SA2724001	F -35	12	SA3711001	C -9	6
SA2463001	B -31	4	SA2565001	G1 -44	16		L -20	22	SA3712001	C -10	6
SA2464001	B -18	4	SA2566001	F -15	12	SA2727101	L -31	22	SA3840001	F -10	12
SA2469001	B -33	4	SA2567001	G1 -46	16	SA2746201	B -1	4	SA3848001	C -17	6
SA2471001	C -23	6	SA2568001	G1 -47	16	SA2748001	B -23	4	SA3852001	C -19	6
SA2474101	C -3	6	SA2571001	J -5	20	SA2750001	B -26	4	SA3854001	C -2	6
SA2475001	C -5	6	SA2574001	G1 -21	14	SA2754001	F -37	12	SA3855001	F -1	12
SA2479001	A -13	2		G1 -21	16	SA2755101	G1 -1	14	SA3856001	G1 -8	14
	A -15	2		G1 -24	14	SA2757201	G1 -33	14		G1 -8	14
	A -24	2		G1 -24	16	SA2759001	J -6	20	SA3859001	G1 -9	14
SA2481001	C -26	6	SA2575001	G1 -22	14	SA2761001	A -23	2	SA3864001	F -11	12
SA2482001	C -11	6		G1 -22	16	SA2768101	Z1 -37	30	SA3886001	F -12	12
SA2483001	C -12	6		J -7	20	SA2769001	Z1 -38	30	SA3887001	F -21	12
SA2484001	C -13	6	SA2576001	G1 -23	14	SA2770101	Z1 -39	30	SA3888001	F -22	12
SA2485001	C -20	6		G1 -23	16	SA2806001	F -31	12	SA3889101	G1 -13	14
	C -27	6	SA2579001	G1 -35	16	SA2814101	L -13	22	SA3890001	J -1	20
SA2486101	C -30	6	SA2582001	Z1 -20	30	SA2818001	M -1	26	SA3891001	J -3	20
SA2489001	C -33	6	SA2584001	J -8	20	SA2824001	M -20	26	SA3894001	G1 -31	14
SA2490101	C -36	6	SA2585001	E -12	10	SA2825001	G1 -40	16		G1 -31	16
SA2493001	C -42	6		J -10	20	SA2827001	G1 -51	16	SA3896001	L -22	22
SA2494001	C -43	6		J -14	20	SA2861001	B -13	4	SA3898001	L -26	22
SA2495001	D -1	8	SA2587001	J -12	20	SA2867001	Z2 -7	32	SA3916001	G1 -39	16
SA2496001	D -7	8	SA2590001	Z1 -21	30	SA2927001	F -13	12	SA3923001	L -50	22
SA2498001	D -8	8	SA2596001	L -39	22	SA2928001	F -29	12	SA3924001	A -2	2
SA2499001	D -10	8	SA2597001	L -40	22	SA2929001	A -4	2	SA3946001	L -4	22
SA2500001	D -16	8	SA2598001	L -41	22		A -19	2	SA3949001	L -14	22
SA2501001	D -17	8	SA2599001	L -23	22		A -20	2	SA3961001	G1 -2	14
SA2502001	D -18	8		L -27	22		L -8	22	SA3965001	F -2	12
SA2504001	D -21	8	SA2604001	L -52	22		L -16	22	SA3988001	G1 -38	16
SA2506001	D -26	8	SA2605001	L -53	22	SA2935101	B -14	4	SA3990001	F -20	12
SA2507001	D -27	8	SA2606101	L -57	22	SA2936101	B -14	4	SA4007001	C -15	6
SA2509001	E -1	10	SA2607001	M -1	26	SA2950101	G1 -1	14	SA4009001	F -33	12
SA2511001	E -2	10	SA2613001	M -4	26	SA2951101	G1 -33	14	SA4011001	F -36	12
SA2512001	E -4	10	SA2614001	M -5	26	SA2956001	L -5	22	SA4012001	G1 -30	14

## 索引 / INDEX

CODE	REF.NO	Page	CODE	REF.NO	Page	CODE	REF.NO	Page	CODE	REF.NO	Page
SA4012001	G1 - 30	16									
SA4014001	L - 61	24									
SA4025001	F - 30	12									
SA4026001	G1 - 14	14									
SA4028001	F - 3	12									
SA4029001	G1 - 3	14									
SA4033001	L - 11	22									
SA4038001	G1 - 4	14									
SA4042001	G1 - 26	14									
SA4043001	G1 - 36	16									
SA4044001	G1 - 28	14									
SA4045001	G1 - 37	16									
SA4049001	Ga	35									
SA4053001	Ga	35									
SA4089001	B - 2	4									
SA4093001	C - 22	6									
SA4094001	C - 25	6									
SA4095001	C - 29	6									
SA4112001	B - 16	4									
SA4115001	B - 21	4									
SA4116001	B - 21	4									
SA4117001	C - 38	6									
SA4118001	C - 40	6									
SA4124101	C - 1	6									
SA4129001	B - 22	4									
	D - 31	8									
SA4205001	L - 1	22									
SA4212001	M - 3	26									
SA4213001	J - 15	20									
SA4214001	B - 30	4									
SA4215001	L - 10	22									
SA4313001	Z2 - 39	32									
SA4335001	B - 6	4									
SA4444001	G1 - 4	14									
SA4506001	M - 34	26									
SA4507001	M - 35	26									
SA4549001	G1 - 20	14									
	G1 - 20	16									
W01519001	F - 32	12									

**brother**®

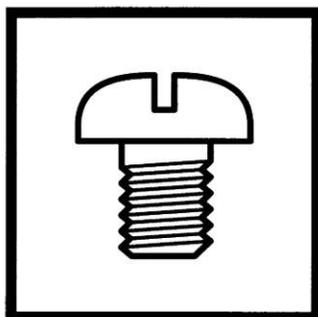

パーツブック  
PARTS BOOK

**ブラザー工業株式会社**

**BROTHER INDUSTRIES, LTD.**

---

T-8420B  
SA2763-101  
2005.01.ZB (1)