

brother

MA4-B551

超高速安全縫ミシン

HIGH SPEED SAFETY STITCH SEWING MACHINE

SICHERHEITS-SCHNELLNÄHMASCHINE

MACHINE A POINT DE SURETE A HAUTE VITESSE

MAQUINA PARA COSTURA DE SEGURIDAD RAPIDA

パーツブック

PARTS BOOK

TEILEKATALOG

LIVRE DES PIECES

LIBRO DE REFERENCIA DE PIEZAS

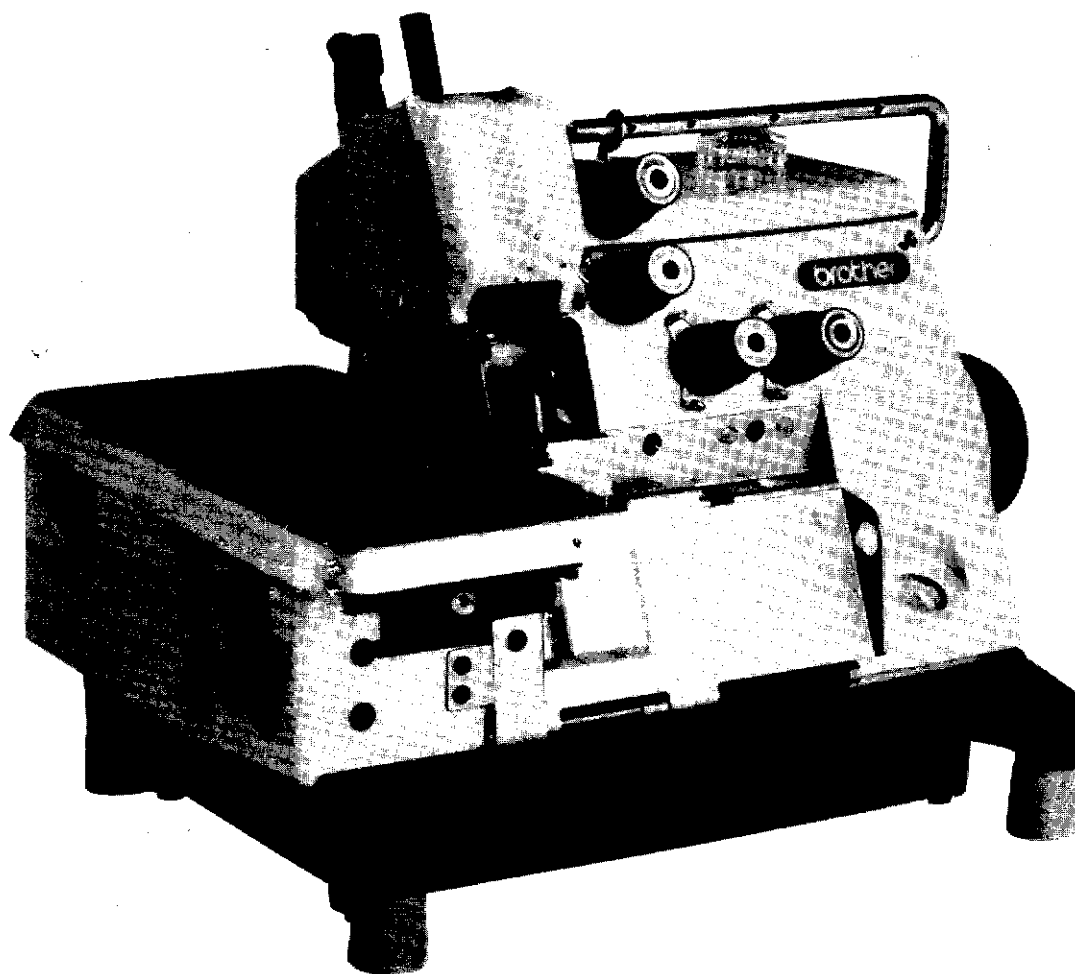

P551701



パーツブックご利用に際して

1. この本は、この本の表紙（正誤表の挿入されている場合は正誤表）に記載されているものと同じプレートが取り付けられているミシンのためのものです。
2. 標準以外で使用する部品は

067 000

 で示します。尚実線内の数字はサブクラスを表わしています。
3. RMKS 欄に※印のついている部品は、相手部品との共合せ加工がなされていますので、相手部品と一緒に、ご注文下さい。
4. 組単位で補給する部品は、 破線で示しております。
5. この本は1988年9月のデータに基づいて作成されたものです。
6. 部品は予告なしに設計変更される場合があります。
7. 部品コード欄が*となっている場合は、仕様別部品一覧表（49ページ）でお調べ下さい。

目 次

A. フレーム関係.....	2
B. 駆動軸関係.....	6
C. 針冷却装置.....	6
D. 針棒関係.....	8
E. 押エ関係.....	10
F. 送り関係.....	20
G. 上メス・下メス関係.....	24
H. ラフラー装置関係.....	26
J. ヒモ案内関係.....	30
K. テープワインダー関係.....	30
L. ラッパー関係.....	32
M. 下ルーパ関係.....	32
N. 上ルーパ関係.....	34
P. 二重環ルーパ関係.....	36
Q. 給油・潤滑関係.....	38
R. 糸調子関係.....	40
Z. 付属品関係.....	44
仕様別部品一覧表.....	49
索引.....	57
ゲージ部品.....	66

Notes for using this parts book

1. This book is applicable to sewing machines which have the same plate number as shown on the cover of this book (or correction sheet).
2. Non-standard parts are indicated with

067 000

.
Numbers inside the line indicate the subclass.
3. An asterisk ※ in the RMKS indicates a part that is manufactured to fit with a paired part. Be sure to order the pair.
4. Parts supplied as complete assemblies are circled by a dotted line (□□□).
5. This book was prepared based on information available in September 1988.
6. Parts are subject to changes in design without prior notice.
7. If the symbol * is found in the "Parts No." column, refer to the different parts list on page 49.

CONTENTS

A.	Machine body	2
B.	Crank shaft mechanism	6
C.	Needle cooler	6
D.	Needle bar mechanism	8
E.	Presser foot mechanism	10
F.	Feed mechanism	20
G.	Knife mechanism	24
H.	Ruffling attachment	26
J.	Gimp guide mechanism	30
K.	Tape winder mechanism	30
L.	Lapper mechanism	32
M.	Under looper mechanism	32
N.	Over looper mechanism	34
P.	Double chain stitch looper mechanism	36
Q.	Lubrication	38
R.	Thread tension	40
Z.	Accessories	44
	DIFFERENT PARTS LIST	49
	INDEX	57
	GAUGE PARTS	66

Anmerkungen zum Gebrauch dieses Stücklistebuches

1. Dieses Buch bezieht sich auf die Nähmaschinen mit derselben Kennungsnummer wie auf diesem Buchumschlag (oder auf dem Korrekturblatt).
2. Die Sonderteile sind mit

067 000

 bezeichnet.
Die Nummern im gestrichelten Feld geben die Unterbezeichnung an.
3. Mit einem Asterisk ※ sind Teile bezeichnet, die nur mit anderen Teilen zusammen verwendet werden können. Sie müssen daher alle zusammengehörige Teile miteinander bestellen.
4. Die Teile, die als kompletter Satz geliefert werden, sind mit einer

--

 gestrichelten Linie umrandet.
5. Dieses Buch basiert auf den Informationen vom September 1988.
6. Modelländerungen sind vorbehalten.
7. Dieses Zeichen * in der Spalte "Parts No. (Teil-nummer)" verweist auf die Gesonderte Stückliste auf Seite 49.

INHALTSVERZEICHNIS

A.	Maschinengehäuse	2
B.	Kurbelwelle	6
C.	Nadelkühlungsvorrichtung	6
D.	Nadelstangenvorrichtung	8
E.	Stoffdrückerfuß	10
F.	Transportvorrichtung	20
G.	Messer	24
H.	Kräuselvorrichtung	26
J.	Schnurführung	30
K.	Bandaufwickelvorrichtung	30
L.	Falz-Mechanismus	32
M.	Unterer Greifer	32
N.	Oberer Greifer	34
P.	Doppelkettenstichgreifer	36
Q.	Schmierung	38
R.	Faderspannung	40
Z.	Zubehör	44
	ZUBEHÖRLISTE	49
	VERZEICHNIS	57
	TEILE DER LEHRE	66

Notes sur l'utilisation de ce manuel de pièces détachées

1. Ce manuel est destiné aux machines à coudre ayant le même numéro de plaque montré sur la couverture de ce manuel (ou sur la feuille de corrections).
2. Les pièces non standard sont signalées par l'indication

067
000

.
Les numéros à l'intérieur du cadre en pointillés indique la sous-classe.
3. Un astérisque * dans le RMKS indique une pièce qui est fabriquée pour correspondre avec une pièce jumelée. S'assurer de commander la paire.
4. Les pièces fournies en tant qu'assemblages complets sont encadrées avec un trait pointillé [] .
5. Ce manuel a été fait d'après les renseignements valables au mois de Septembre 1988.
6. Les pièces peuvent être sujettes à des modifications sans préavis.
7. Si le symbole * se trouve dans la colonne "Parts No. (N° de pièce)" veuillez la vous référer à la liste de pièces annexe page 49.

TABLE DES MATIERES

A.	Corps de la machine	2
B.	Mécanisme du vilebrequin	6
C.	Mécanisme du refroidisseur d'aiguille	6
D.	Mécanisme de la barre à aiguille	8
E.	Mécanisme du pied presseur	10
F.	Mécanisme de l'entraînement	20
G.	Mécanisme du couteau	24
H.	Accessoire pour fronces	26
J.	Mécanisme du guide-fil	30
K.	Mécanisme de l'enrouleur de ruban	30
L.	Mécanisme à rabat	32
M.	Mécanisme du boucleur inférieur	32
N.	Mécanisme du boucleur supérieur	34
P.	Mécanisme du boucleur pour point de chaînette double	36
Q.	Lubrification	38
R.	Tension du fil	40
Z.	Accessoires	44
	LISTE DES PIECES ACCESSOIRES	49
	INDEX	57
	PIECES DE JAUGE	66

Notas para usar este Libro de Piezas

1. Este libro sirve para todas las máquinas de coser que llevan la misma placa de identificación que la que se puede ver en la tapa de este libro (o en la hoja de erratas).
2. Las piezas no normales aparecen como

067
000

.
Los números dentro del rectángulo punteado indican la subclase.
3. Un asterisco ※ en el RMKS indica que la pieza forma parte de un par. Se debe hacer el pedido en pares.
4. Las piezas suministradas como conjuntos completos se enmarcan con una línea punteada (----).
5. Este libro ha sido compilado basándose en los datos de que se disponía en Septiembre 1988.
6. Las piezas quedan sujetas a cambios de diseño sin aviso previo.
7. De haber un símbolo * junto al "Parts No. (Número de Pieza)", habrá que mirar la lista de piezas separada de la página 49.

INDICE

A.	Cuerpo de la máquina	2
B.	Mecanismo del cigüeñal	6
C.	Mecanismo del enfriador de aguja	6
D.	Mecanismo del barra de aguja	8
E.	Mecanismo del prensa telas	10
F.	Mecanismo de la alimentación	20
G.	Mecanismo del cuchilla	24
H.	Accesorio de fruncido	26
J.	Mecanismo guía del hilo	30
K.	Mecanismo bobinador de cinta	30
L.	Mecanismo de solapado	32
M.	Mecanismo del presilladora inferior	32
N.	Mecanismo del presilladora superior	34
P.	Mecanismo del presilladora de doble cadeneta	36
Q.	Lubricación	38
R.	Tension del hilo	40
Z.	Accesorios	44
	LISTA DE PIEZAS ACCESORIAS	49
	INDICE	57
	PIEZAS DE CALIBRE	66

A. フレーム関係 / Machine body / Maschinengehäuse /
 Corps de la machine / Cuerpo de la máquina

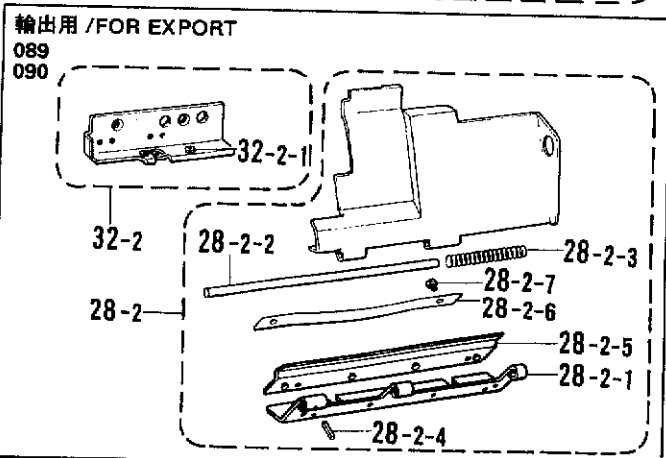
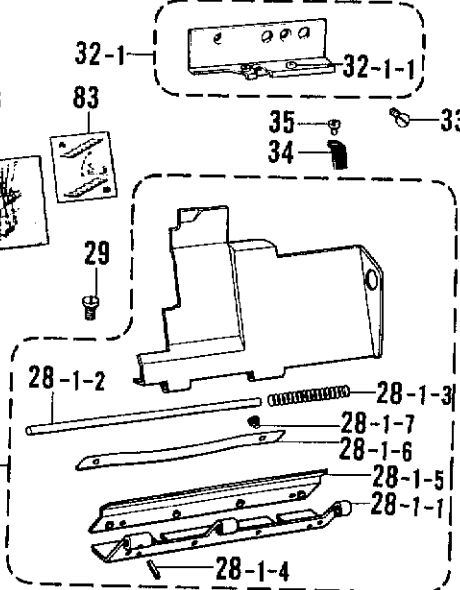
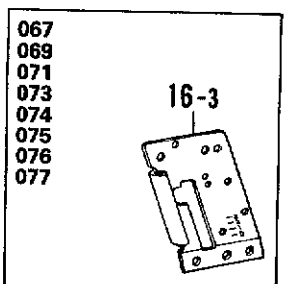
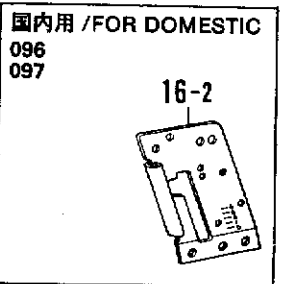
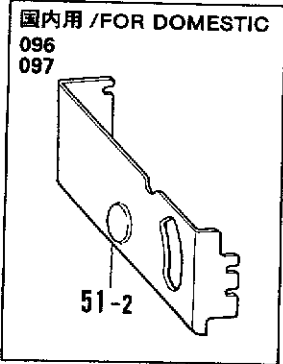
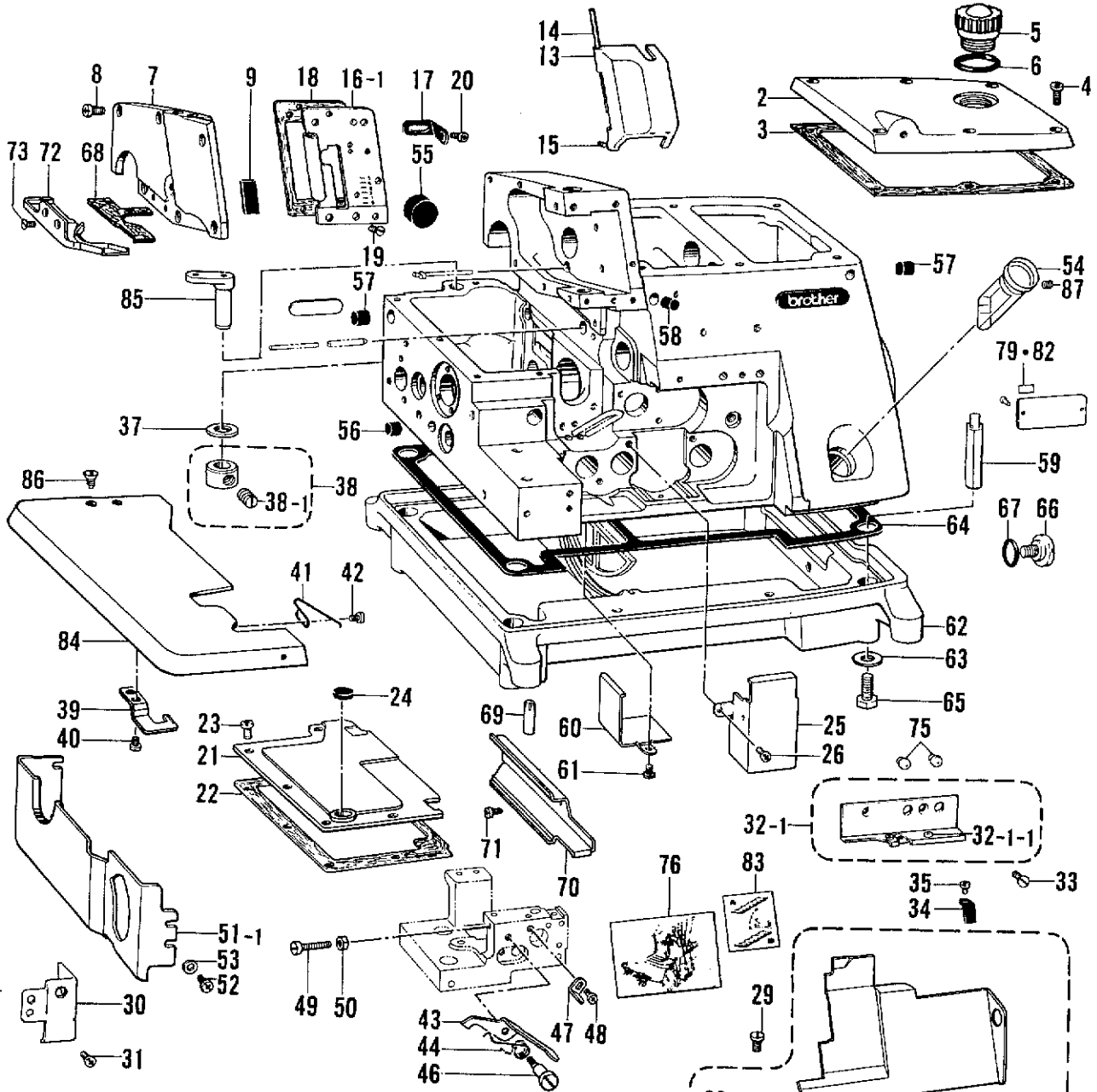

A. フレーム関係 / Machine body / Maschinengehäuse /
Corps de la machine / Cuerpo de la máquina

REF.NO.	CODE	Q'TY	ヒンメイ	NAME OF PARTS	RMKS
2	146419001	1	ウツカハ"	TOP COVER	
3	146420000	1	ハ"ツキン	PACKING	
4	062681412	6	ナヘ"コ437-40X14	SCREW 437X14	
5	146421000	1	オイルクチキャップ"	CAP FOR OIL FEDDING HOLE	
6	113589001	1	オイルマト"ハ"ツキン	PACKING	
7	146422001	1	ソクメンカハ"	COVER FOR NEEDLE DRIVING MECHANISM	
8	062680712	6	ナヘ"コ437-40X7	SCREW 437X7	
9	143992001	1	ゴムフ"タ	RUBBER CAP	
13	146425001	1	メンイタカハ"	FACE PLATE COVER	
14	146426000	1	ヒンジ"シ"ク	HINGE SHAFT	
15	146427001	1	アナトメネジ"3.18クホ"ミ	SCREW 3.18	
16-1	146428001	1	メンイタクミ	FACE PLATE ASSEMBLY	
16-2	146706001	1	メンイタクミ	-----	
16-3	146430001	1	メンイタクミ	FACE PLATE ASSEMBLY	
17	146432001	1	トメイタハ"ネ	STOPPER SPRING PLATE	
18	146433000	1	ハ"ツキン	FACE PLATE PACKING	
19	102843004	3	サラネジ"3.57	SCREW 3.57	
20	062670612	2	ナヘ"コ357-40X6	SCREW 357X6	
21	146434000	1	オクリタ"イカハ"	COVER FOR FEED MECHANISM	
22	146435000	1	ハ"ツキン	PACKING	
23	062680712	5	ナヘ"コ437-40X7	SCREW 437X7	
24	111486001	1	クロスプレートクツション	CLOTH PLATE CUSHION	
25	146436001	1	ウチカハ"	INSIDE COVER	
26	062670612	2	ナヘ"コ357-40X6	SCREW 357X6	
28-1	148997001	1	マエカハ"ークミ	FRONT COVER ASSEMBLY	
28-1-1	146440001	1	マエカハ"ーヒンジ"	FRONT COVER HINGE	
28-1-2	146441000	1	マエカハ"ーヒンジ"シ"ク	FRONT COVER HINGE SHAFT	
28-1-3	146442001	1	マエカハ"ーハ"ネ	FRONT COVER SPRING	
28-1-4	047140842	1	スプリング"ピン1.4X8	SPRING PIN 1.4X8	
28-1-5	148984001	1	ヒンジ"カハ"	HINGE COVER	
28-1-6	152194001	1	ヒンジ"カハ"ーオサエイタ	HINGE COVER PRESSER PLATE	
28-1-7	062670412	2	ナヘ"コ357-40X4	SCREW 357X4	
28-2	148999001	1	-----	FRONT COVER ASSEMBLY	
28-2-1	146440001	1	-----	FRONT COVER HINGE	
28-2-2	146441000	1	-----	FRONT COVER HINGE SHAFT	
28-2-3	146442001	1	-----	FRONT COVER SPRING	
28-2-4	047140842	1	-----	SPRING PIN 1.4X8	
28-2-5	148984001	1	-----	HINGE COVER	
28-2-6	152194001	1	-----	HINGE COVER PRESSER PLATE	
28-2-7	062670412	2	-----	SCREW 357X4	
29	060680512	2	ハ"イント"437-40X5	SCREW 4.37X5	
30	146443001	1	マエカハ"ーアンナイイタ	FRONT COVER GUIDE PLATE	
31	062670612	2	ナヘ"コ357-40X6	SCREW 357X6	
32-1	146444001	1	マエカハ"ーササイクミ	SUPPORTOR FOR FRONT COVER ASSEMBLY	
32-1-1	146924000	2	スレット"フ"ツシュ	THREAD BUSHING	
32-2	147367001	1	-----	SUPPORTER FOR FRONT COVER ASSEMBLY	
32-2-1	146924000	2	-----	THREAD BUSHING	
33	117160001	2	サラネジ"4.37	SCREW 4.37	
34	154829001	1	マエカハ"ートメイタハ"ネ	STOPPER SPRING FOR FRONT COVER	
35	123185001	1	マルヒラネジ"3.57X4.5	SCREW 3.57X4.5	
37	141183000	1	クロスプレートシート	CLOTH PLATE SEAT	
38	181969003	1	セツトカラークミ	SET COLLAR ASSEMBLY	
38-1	101706001	2	トメネジ"6.35	SCREW 6.35	
39	146449001	1	クロスプレートトメイタ	CLOTH PLATE SUPPORTER	
40	060670512	2	ハ"イント"357-40X5	SCREW 3.57X5	
41	146450001	1	クロスプレートモト"シハ"ネ	SPRING	
42	060670512	1	ハ"イント"357-40X5	SCREW 3.57X5	
43	146451001	1	クロスプレートトメテコ	CLOTH PLATE LEVER	
44	146452001	1	トメテコモト"シハ"ネ	SPRING	
46	146453001	1	タ"ンネジ"3.57	STUD SCREW 3.57	
47	146454001	1	トメテコストツバ"	CLOTH PLATE LEVER STOPPER	
48	062670612	1	ナヘ"コ357-40X6	SCREW 357X6	

A. フレーム関係 / Machine body / Maschinengehäuse /
 Corps de la machine / Cuerpo de la máquina

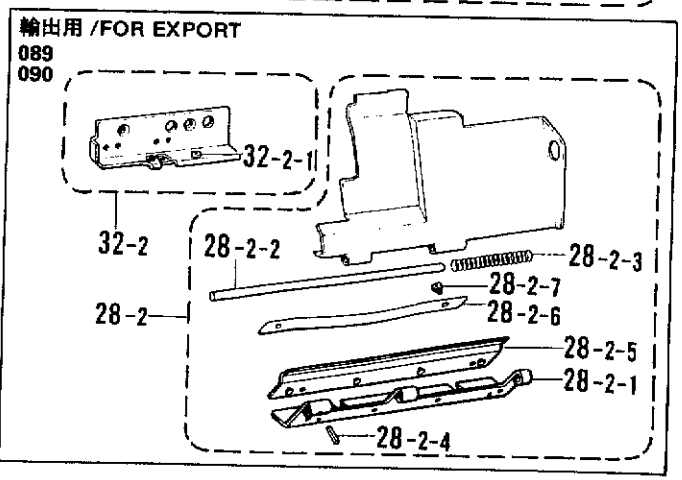
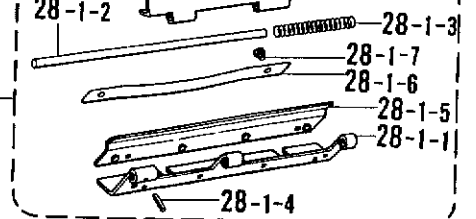
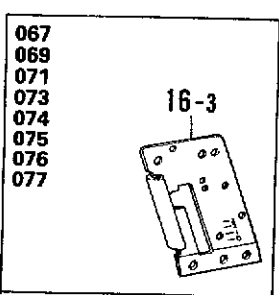
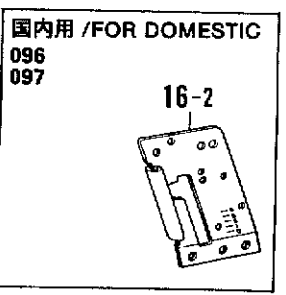
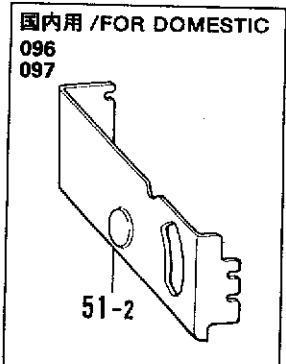
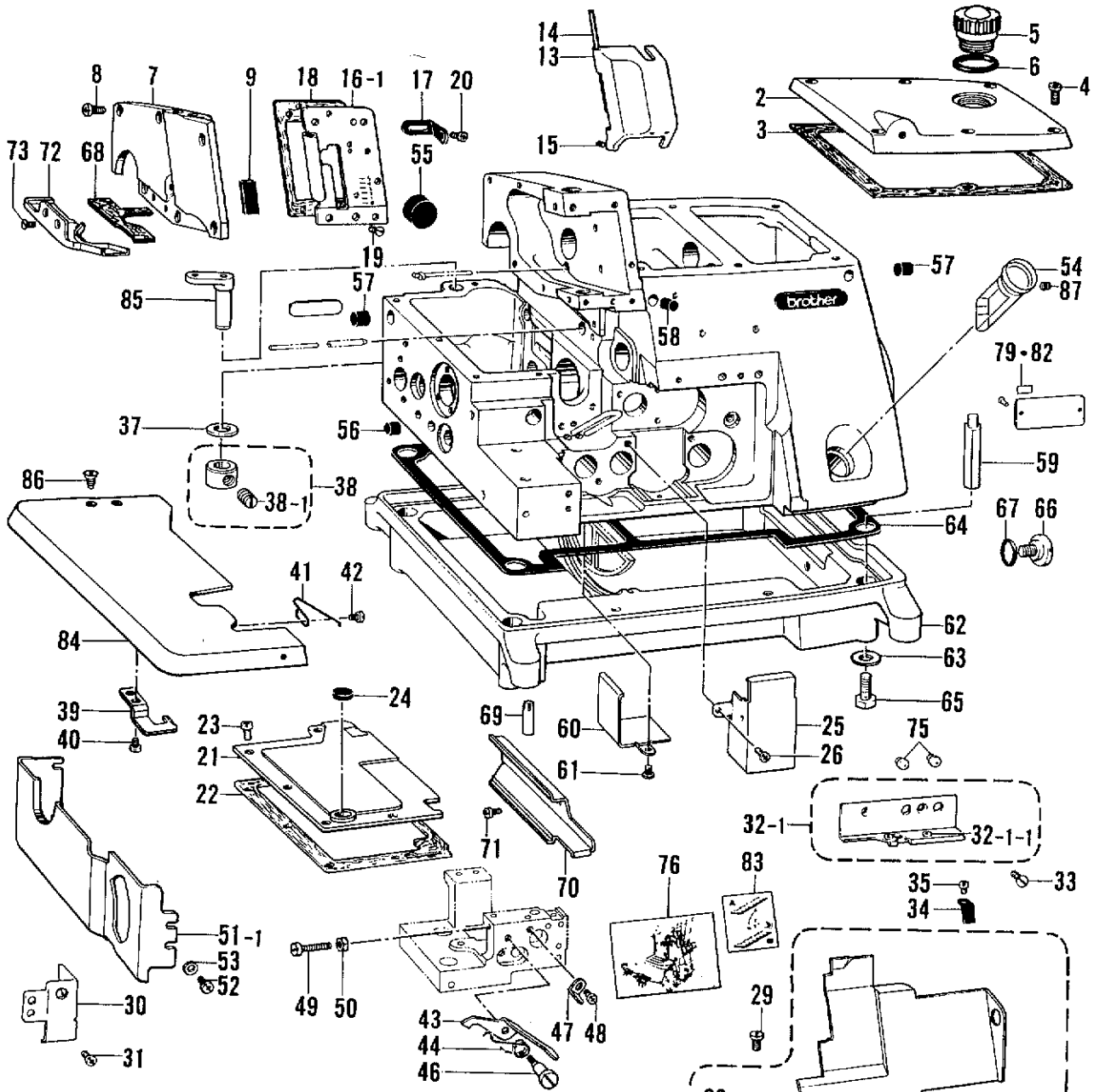

A. フレーム関係/Machine body/Maschinengehäuse/
Corps de la machine/Cuerpo de la máquina

REF.NO.	CODE	Q'TY	ヒンメイ	NAME OF PARTS	RMKS
49	062671412	1	ナヘ"コ357-40X14	SCREW 357X14	
50	021670202	1	ナツト2シユ3.57	NUT 3.57	
51-1	146455101	1	クロスプレートシタ	CLOTH PLATE (LOWER)	
51-2	146717101	1	クロスプレートシタ	-----	
52	062680712	4	ナヘ"コ437-40X7	SCREW 437X7	
53	100645003	4	サ"ガ"ネ	WASHER	
54	148084001	1	オイルゲージ"マト"	OIL GAUGE WINDOW	
55	140066001	2	メクラセン	OIL CAP	
56	140065001	1	メクラセン	OIL CAP	
57	146315000	2	メクラセン	OIL CAP	
58	140421001	2	メクラセン	OIL CAP	
59	151059001	4	ホンタイシチユウ	MACHINE BODY LEG	
60	146457001	1	シクリイタ	OIL STOPPER PLATE	
61	062670612	2	ナヘ"コ357-40X6	SCREW 357X6	
62	S03887201	1	アブ"ラウケ	OIL RESERVOIR	
63	159476000	4	サ"ガ"ネ	WASHER	
64	151060000	1	ハ"ツキン	PACKING	
65	017771612	4	ボ"ルト6.35X16	BOLT 6.35X16	
66	110641002	1	ダ"ンネシ"9.52	STUD SCREW 9.52	
67	109203001	1	Oリング"	O RING	
68	159640000	1	フェルト	FELT	
69	118550001	4	ミゾ"ツキピン	DOWEL PIN	
70	146460001	1	クロスプレートヌノアンナイL	CLOTH GUIDE (LARGE)	
71	062670612	2	ナヘ"コ357-40X6	SCREW 357X6	
72	159639001	1	クロスプレートヌノアンナイS	CLOTH GUIDE (SMALL)	
73	108960002	2	サラネシ"3.57	SCREW 3.57	
75	*	2	オイルニカ"シグ"チ	OIL HOLE BOLT FOR OIL GAUGE	
76	*	1	イトオシセツメイイタ	THREADING DIAGRAM	
79	*	1	シヨウラヘル	LABEL	
82	*	1	シヨウラヘル	LABEL	
83	*	1	ルーパ"イトチヨウセツラヘル	LABEL	
84	S09323001	1	クロスプレート	CLOTH PLATE	
85	143374001	1	クロスプレートササエシ"ク	CLOTH PLATE SUPPORTING SHAFT	
86	100032003	2	サラネシ"4.37	SCREW 4.37	
87	014680422	1	アナトメネシ"4.37クホ"ミ	SCREW 4.37	

B. 駆動軸関係 / Crank shaft mechanism / Kurbelwelle /
 Mécanisme du vilebrequin / Mecanismo del cigüeñal

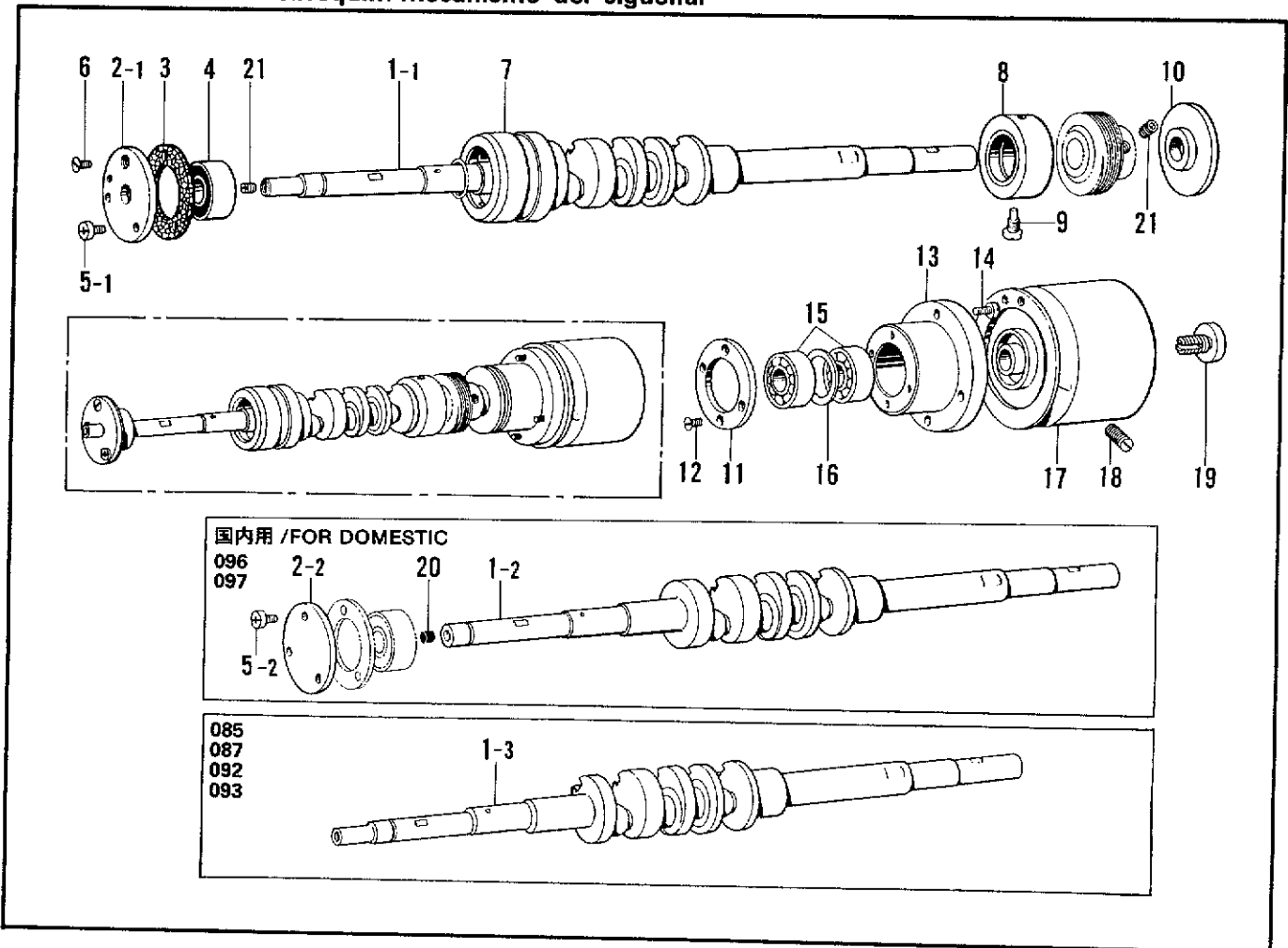

C. 針冷却装置 / Needle cooler / Nadelkühlungsvorrichtung /
 Mécanisme du refroidisseur d'aiguille / Mecanismo del enfriador de aguja

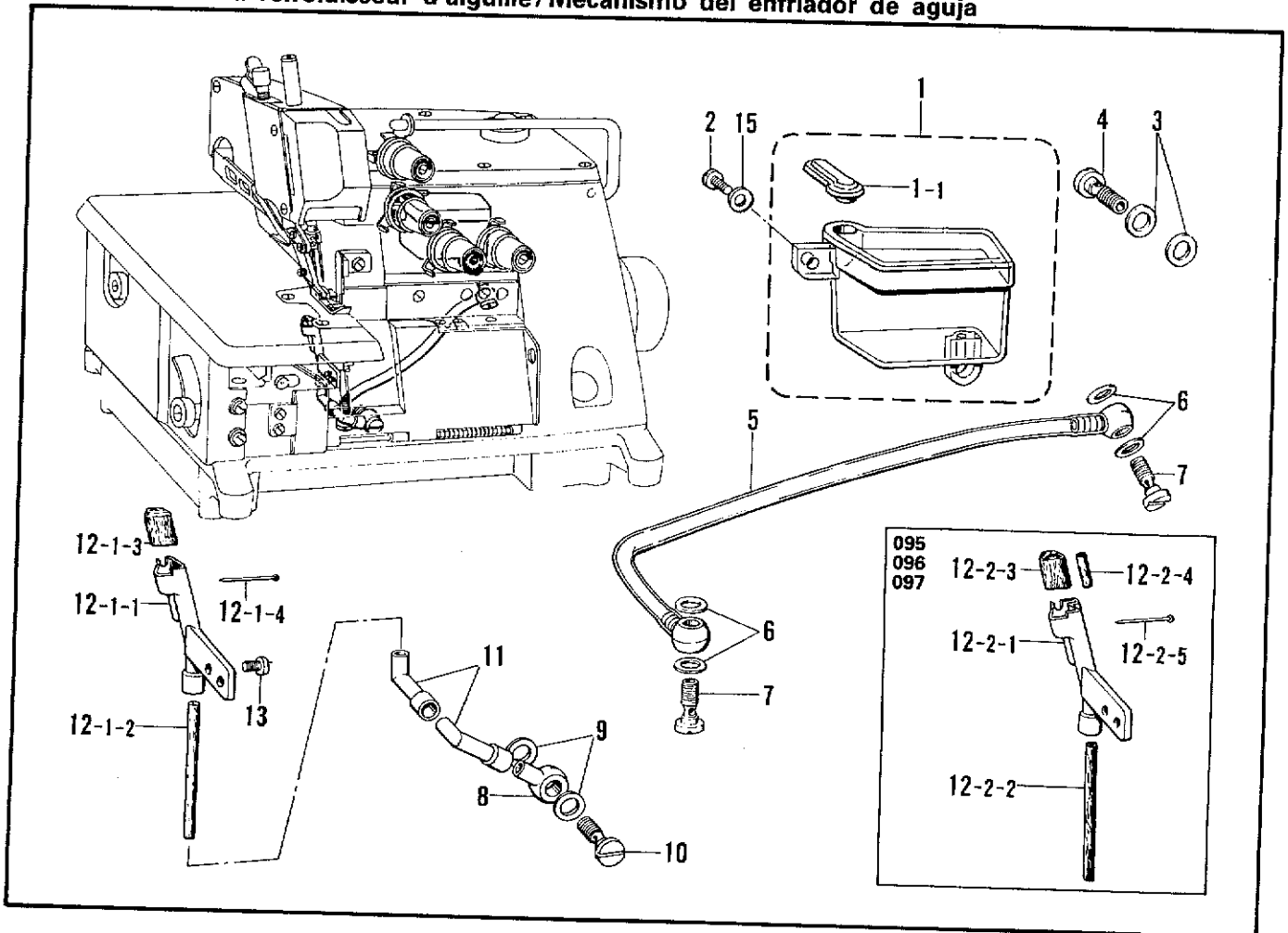

**B. 駆動軸関係/Crank shaft mechanism/Kurbelwelle/
Mécánisme du vilebrequin/Mecanismo del cigüeñal**

REF.NO.	CODE	Q'TY	ヒンメイ	NAME OF PARTS	RMKS
1-1	146471001	1	ク"ウシ"クC	CRANK SHAFT (C)	※
1-2	S01790001	1	ク"ウシ"クH	-----	※
1-3	S07848001	1	ク"ウシ"クJ	CRANK SHAFT (J)	※
2-1	150806001	1	ハ"アリング"フタ	BEARING CAP	
2-2	143311001	1	ハ"アリング"フタ	-----	
3	143312000	1	ハ"アリング"フタパ"ツキン	BEARING CAP PACKING	
4	072600000	1	タマジ"クウケ6000	BEARING 6000	
5-1	062670812	2	ナヘ"コ357-40X8	SCREW 357X8	
5-2	062670812	3	ナヘ"コ357-40X8	-----	
6	102538002	1	サラネシ"3.57	SCREW 3.57	
7	146473001	1	ク"ウシ"クメタルLクミ	CRANK SHAFT BUSHING (LEFT) ASSEMBLY	
8	143179000	1	ク"ウシ"クメタルMクミ	CRANK SHAFT BUSHING (MIDDLE) ASSEMBLY	
9	110668001	1	シメネシ"4.76	SCREW 4.76	
10	140084000	1	オイルキリ	OIL REJECTOR	
11	110673000	1	ハ"アリング"フタ	BEARING COVER	
12	107244001	4	サラネシ"3.18	SCREW 3.18	
13	110670000	1	ハ"アリング"ケース	BEARING CASE	
14	062681012	4	ナヘ"コ437-40X10	SCREW 437X10	
15	072600100	2	タマジ"クウケ6001	BEARING 6001	
16	110672000	1	ハ"アリング"カラー	THRUST WASHER	
17	147848101	1	プ"ーリー	PULLEY	
18	013761410	2	トメネシ"5.95クホ"ミ	SCREW 5.95	
19	140180001	1	プ"ーリオサエネシ"	CAP SCREW	
20	142274001	1	メクラセン	OIL CAP	
21	013719412	2	トメネシ"4.76クホ"ミ	SCREW 4.76	

※クドウジクCクミ (B-1-1) 146917-001 ※ Crank Shaft (C) Assembly (B-1-1) 146917-001
 ※クドウジクHクミ (B-1-2, D-1, M-1, N-1) S01789-001 ※ Crank Shaft (H) Assembly (B-1-2, D-1, M-1, N-1) S01789-001
 ※クドウジクJクミ (B-1-3) S07847-001 ※ Crank Shaft (J) Assembly (B-1-3) S07847-001

**C. 針冷却装置/Needle cooler/Nadelkühlungsvorrichtung/
Mécánisme du refroidisseur d'aiguille/Mecanismo del enfriador de aguja**

REF.NO.	CODE	Q'TY	ヒンメイ	NAME OF PARTS	RMKS
1	146511100	1	エキレイタンククミ	SILICONE OIL TANK ASSEMBLY	
1-1	154928000	1	ハリイトレイキヤクタンクフタ	NEEDLE THREAD COOLER TANK COVER	
2	062681012	1	ナヘ"コ437-40X10	SCREW 437X10	
3	112348001	2	パ"ツキン	PACKING	
4	112359001	1	ハイユハ"イフ"ツキ"テネシ"	SCREW	
5	146512101	1	ビ"ニルチューブ"クミ	VINYL TUBE ASSEMBLY	
6	112348001	4	パ"ツキン	PACKING	
7	112359001	2	ハイユハ"イフ"ツキ"テネシ"	SCREW	
8	146515000	1	ハイユハ"イフ"ツキ"テ	OIL FEEDING PIPE CONNECTOR	
9	112348001	2	パ"ツキン	PACKING	
10	112359001	1	ハイユハ"イフ"ツキ"テネシ"	SCREW	
11	146516000	2	ハ"イフ"シ"ヨイント	PIPE JOINT	
12-1	146517100	1	フェルトササエクミ	FELT HOLDER ASSEMBLY	
12-1-1	146518100	1	フェルトササエ	FELT HOLDER	
12-1-2	144116000	1	フェルト	FELT	
12-1-3	151475000	1	フェルトS	FELT (SMALL)	
12-1-4	S02874001	1	ムシピン	PIN	
12-2	156505000	1	フェルトササエクミ	FELT HOLDER ASSEMBLY	
12-2-1	156506000	1	フェルトササエ	FELT HOLDER	
12-2-2	144116000	1	フェルト	FELT	
12-2-3	151475000	1	フェルトS	FELT (SMALL)	
12-2-4	146740000	1	フェルトS	FELT (SMALL)	
12-2-5	S02874001	1	ムシピン	PIN	
13	100257010	2	シメネシ"3.57	SCREW 3.57	
15	100645003	1	サ"ガ"ネ	WASHER	

D. 針棒関係 / Needle bar mechanism / Nadelstangenvorrichtung /
 Mécanisme de la barre à aiguille / Mecanismo del barra de aguja

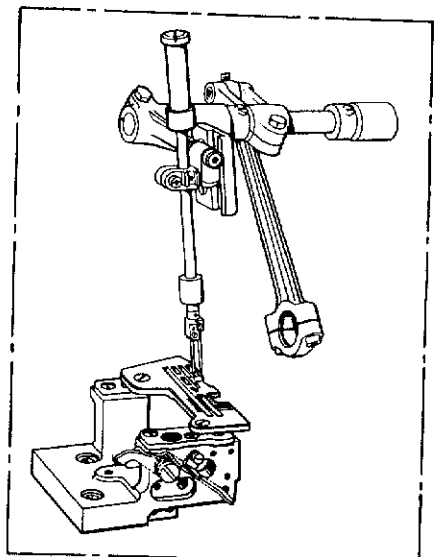
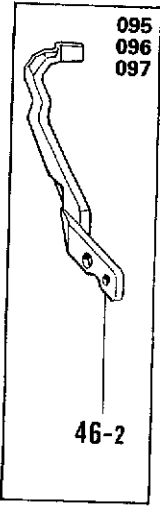
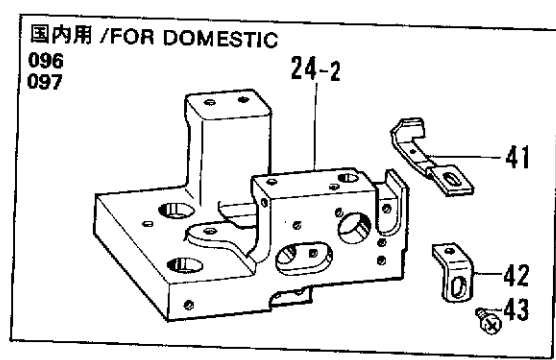
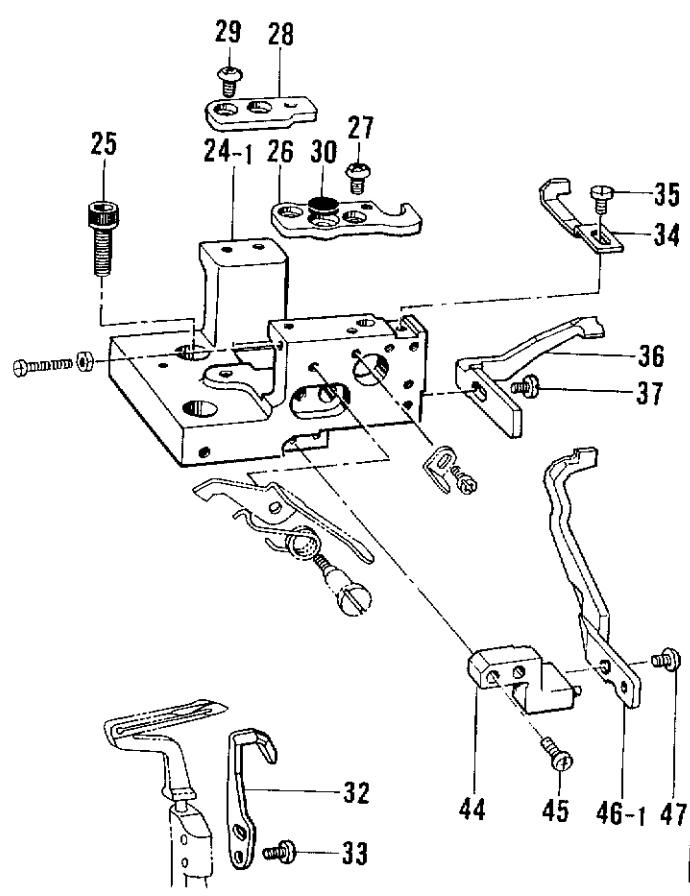
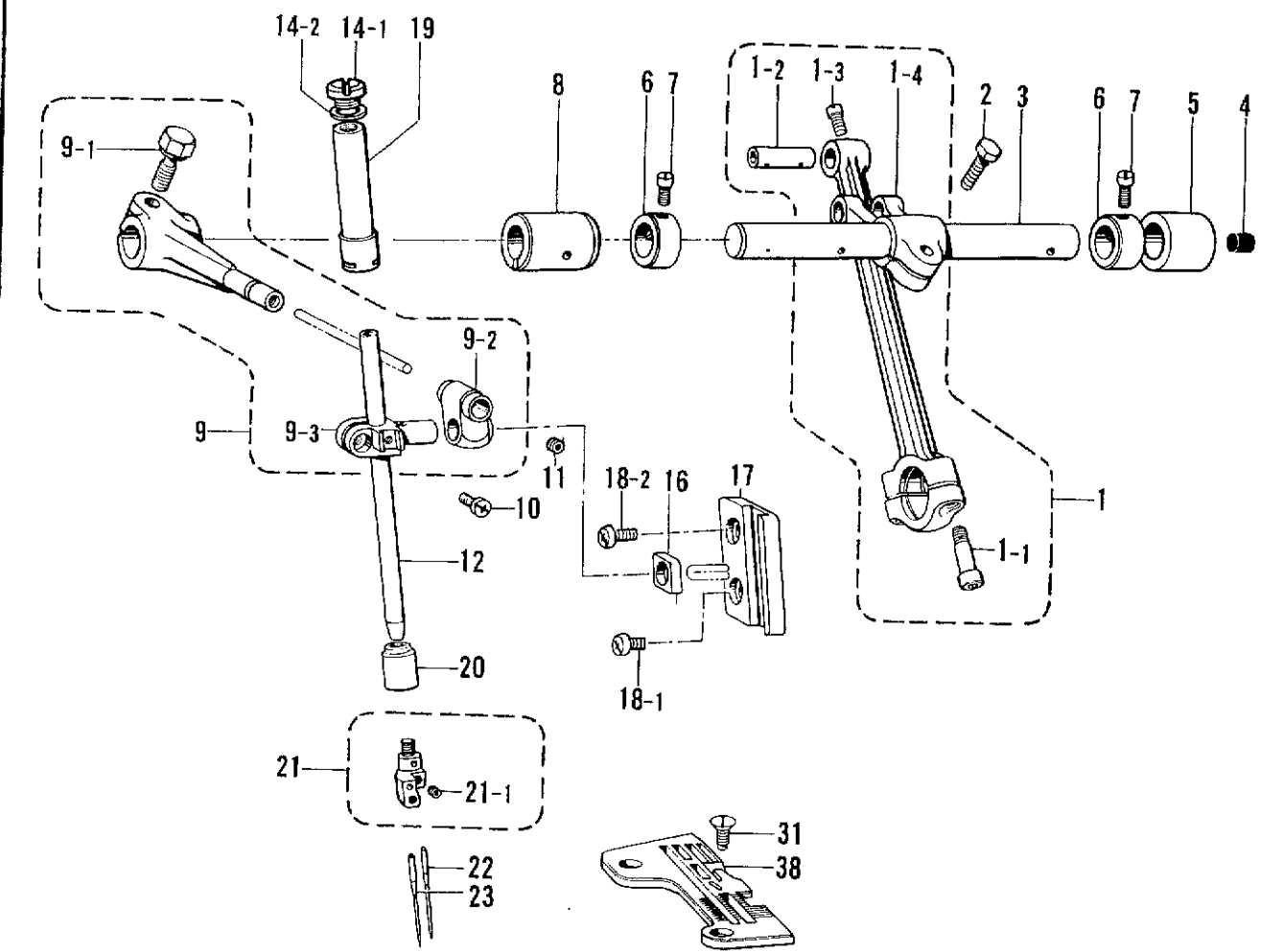

D. 針棒関係/Needle bar mechanism/Nadelstangenvorrichtung/
Mécánisme de la barre à aiguille/Mecanismo del barra de aguja

REF.NO.	CODE	Q'TY	ヒンメイ	NAME OF PARTS	RMKS
1	146476101	1	ハリホ"ウクランクロツト"クミ	NEEDLE ARM DRIVING CRANK ROD ASSEMBLY	※
1-1	148425001	2	アナホ"ルト4.37X14	BOLT 4.37X14	
1-2	140088001	1	クランクロツト"ヒン	PIN	
1-3	100366001	1	マルヒラトメネシ"4.37	SCREW 4.37	
1-4	146478001	1	ハリホ"ウクランクシ"クウテ"	NEEDLE ARM DRIVING LEVER	
2	017771612	1	ホ"ルト6.35X16	BOLT 6.35X16	
3	146479001	1	ハリホ"ウクランクシ"ク	NEEDLE BAR CRANK SHAFT	
4	140327001	1	ゴ"ムセン	OIL CAP	
5	140091000	1	クランクシ"クメタルR	NEEDLE SHAFT BUSHING (RIGHT)	
6	140092001	2	セツトカラー	SET COLLAR	
7	100366001	4	マルヒラトメネシ"4.37	SCREW 4.37	
8	140093000	1	クランクシ"クメタルL	NEEDLE SHAFT BUSHING (LEFT)	
9	146480001	1	ハリホ"ウタ"キクミ	NEEDLE BAR CLAMP ASSEMBLY	
9-1	149170001	1	ホ"ルト6.35X16	BOLT 6.35X16	
9-2	140096001	1	ハリホ"ウツキ"テ	NEEDLE BAR CONNECTOR	
9-3	146482001	1	ハリホ"ウタ"キ	NEEDLE BAR CLAMP	
10	062670812	1	ナヘ"コ357-40X8	SCREW 357X8	
11	146427001	1	アナトメネシ"3.18クホ"ミ	SCREW 3.18	
12	146483001	1	ハリホ"ウ	NEEDLE BAR	
14	S01652001	1	シメネシ"クミ	SCREW ASSEMBLY	
14-1	S00049001	1	シメネシ"8.73	SCREW 8.73	
14-2	S01654000	1	ハ"ツキン	PACKING	
16	159638001	1	ハリホ"ウアンナイカクコマ	NEEDLE BAR GUIDE SLIDE BLOCK	
17	105079001	1	ハリホ"ウアンナイ	NEEDLE BAR GUIDE	
18-1	062680712	1	ナヘ"コ437-40X7	SCREW 437X7	
18-2	S10774001	1	ナヘ"コ437-40X7	SCREW 437X7	
19	S01417001	1	ハリホ"ウメタルU	NEEDLE BAR BUSHING (UPPER)	
20	159636000	1	ハリホ"ウメタルD	NEEDLE BAR BUSHING (LOWER)	
21	*	1	ハリト"メクミ	NEEDLE CLAMP ASSEMBLY	
21-1	146427001	2	アナトメネシ"3.18クホ"ミ	SCREW 3.18	
22	*	※	ミシンハリDCX1	NEEDLE DCX1	
23	*	1	ミシンハリDMX13	NEEDLE DMX13	
24-1	146493102	1	ハリイタササエタ"イ	NEEDLE PLATE SUPPORT BRACKET	
24-2	S01947101	1	ハリイタササエタ"イ	-----	
25	018061622	2	アナホ"ルト6X16	BOLT 6X16	
26	146494001	1	ハリイタササエタF	NEEDLE PLATE SUPPORTER (FRONT)	
27	060680512	2	ハ"イント"437-40X5	SCREW 4.37X5	
28	146495001	1	ハリイタササエタB	NEEDLE PLATE SUPPORTER (REAR)	
29	060680512	2	ハ"イント"437-40X5	SCREW 4.37X5	
30	111486001	1	クロスプレートクッション	CLOTH PLATE CUSHION	
31	100032003	2	サラネシ"4.37	SCREW 4.37	
32	144127001	1	イト"ウハリウケA	MOVABLE NEEDLE GUARD (A)	
33	062670812	2	ナヘ"コ357-40X8	SCREW 357X8	
34	146496301	1	ニジ"ユウカンハリウケF	DOUBLE CHAIN STITCH NEEDLE GUARD (FRONT)	
35	062670612	1	ナヘ"コ357-40X6	SCREW 357X6	
36	146497201	1	ニジ"ユウカンハリウケB	DOUBLE CHAIN STITCH NEEDLE GUARD (REAR)	
37	062680712	1	ナヘ"コ437-40X7	SCREW 437X7	
38	*	1	ハリイタ	NEEDLE PLATE	
41	S01758001	1	タンカンハリウケF	-----	
42	S01948001	1	ハリウケトリツケイタ	-----	
43	062670412	1	ナヘ"コ357-40X4	-----	
44	S09456001	1	ハリウケ"タ"イクミ	NEEDLE GUIDE BRACKET ASSEMBLY	
45	062671412	2	ナヘ"コ357-40X14	SCREW 357X14	
46-1	S09459001	1	オー"ハ"ーハリウケF	NEEDLE GUARD (FRONT)	
46-2	S09460001	1	オー"ハ"ーハリウケF	NEEDLE GUARD (FRONT)	
47	062670812	1	ナヘ"コ357-40X8	SCREW 357X8	

※クドウジクCクミ (B-1-1)
※クドウジクHクミ (B-1-2, D-1, M-1, N-1)
※クドウジクJクミ (B-1-3)

146917-001
S01789-001
S07847-001

※Crank Shaft (C) Assembly (B-1-1)
※Crank Shaft (H) Assembly (B-1-2, D-1, M-1, N-1)
※Crank Shaft (J) Assembly (B-1-3)

146917-001
S01789-001
S07847-001

E. 押工関係/Presser foot mechanism/Stoffdrückerfuß/
 Mécanisme du pied presseur/Mecanismo del prensa telas

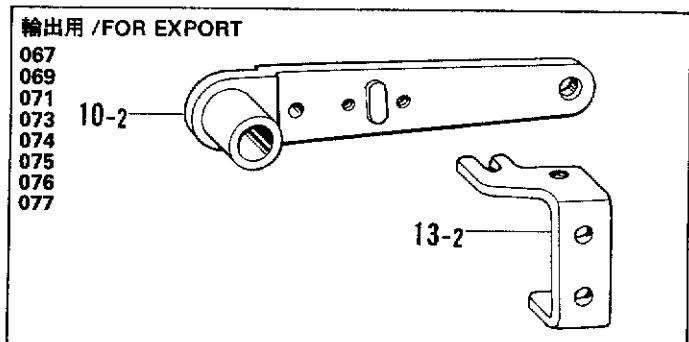
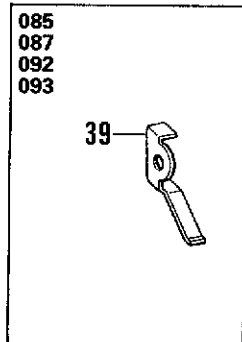
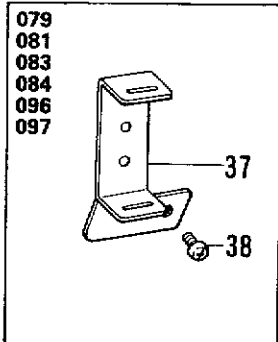
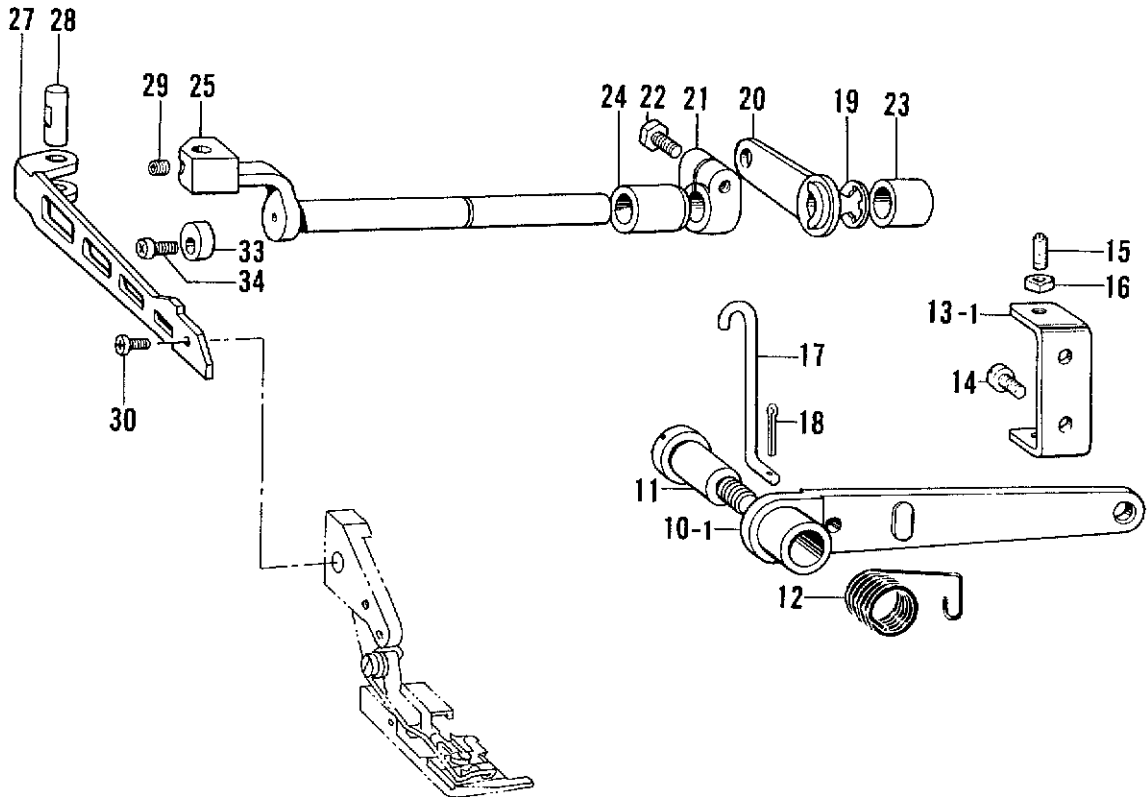
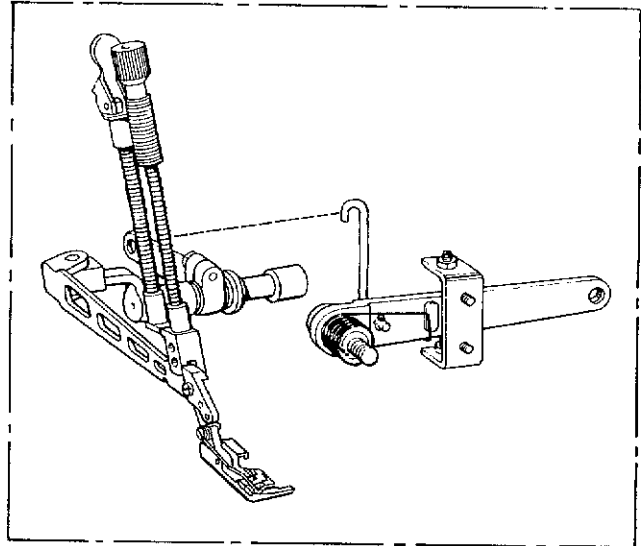
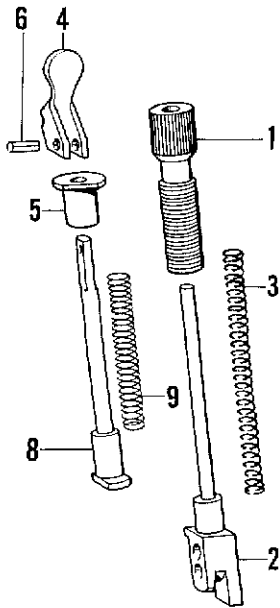

E. 押工関係/Presser foot mechanism/Stoffdrückerfuß/
 Mécanisme du pied presseur/Mecanismo del prensa telas

REF.NO.	CODE	Q'TY	ヒンメイ	NAME OF PARTS	RMKS
1	144079001	1	オサエチヨウセツネジ"	PRESSER ADJUSTING SCREW	
2	146521001	1	オサエホ"ウ	PRESSER BAR	
3	144081001	1	オサエハ"ネ	PRESSER SPRING	
4	S06561001	1	オサエテアケ"	PRESSER BAR LIFTER	
5	144083001	1	オサエテアケ"サ"	PRESSER BAR LIFTER BASE	
6	047300842	1	スプリング"ヒンAW3	SPRING PIN AW3	
8	144085001	1	オサエホ"ウアケ"	PRESSER BAR LIFTER SHAFT	
9	144086001	1	オサエホ"ウアケ"ハ"ネ	PRESSER BAR LIFTER SPRING	
10-1	143323103	1	オサエアジアケ"レハ"ー	PRESSER FOOT LIFTER LEVER	
10-2	148369101	1	-----	PRESSER FOOT LIFTER LEVER	
11	148372001	1	タ"ンネシ"7.94	STUD SCREW 7.94	
12	143325001	1	オサエアジアケ"レハ"ーハ"ネ	SPRING	
13-1	146522001	1	レハ"ーチヨウセツイタ	LEVER ADJUSTING PLATE	
13-2	147454001	1	-----	LEVER ADJUSTING PLATE	
14	062680712	2	ナヘ"コ437-40X7	SCREW 437X7	
15	153483001	2	トメネシ"4.76	SCREW 4.76	
16	110161006	2	ナツト4.76	NUT 4.76	
17	146523001	1	オサエアケ"リンク	PRESSER FOOT LIFTER LINK	
18	110793001	1	ワリヒン	PIN	
19	048080342	1	トメワE8	STOP RING E8	
20	146524001	1	オサエアジアケ"MLレハ"ー	PRESSER FOOT LIFTER INSIDE LEVER	
21	140261001	1	セツトカラー	SET COLLAR	
22	017771612	1	ボ"ルト6.35X16	BOLT 6.35X16	
23	140262000	1	オサエウデ"シ"クメタルR	PRESSER ARM SHAFT BUSHING (RIGHT)	
24	140263000	1	オサエウデ"シ"クメタルL	PRESSER ARM SHAFT BUSHING (LEFT)	
25	146525001	1	オサエウデ"シ"ク	PRESSER ARM SHAFT	
27	146526001	1	シユオサエウデ"	MAIN PRESSER ARM	
28	146527001	1	オサエウデ"ヒン	PIN FOR PRESSER ARM SHAFT	
29	014680422	1	アナトメネシ"4.37クホ"ミ	SCREW 4.37	
30	062680712	1	ナヘ"コ437-40X7	SCREW 437X7	
33	S03321001	1	オサエウデ"ストツパ"	PRESSER ARM STOPPER	
34	062711012	1	ナヘ"コ476-32X10	SCREW 476X10	
37	146883001	1	テープ"アンナイ	TAPE GUIDE	
38	062660412	2	ナヘ"コ318-40X4	SCREW 318X4	
39	149267001	1	テ"ニムオサエイタハ"ネ	SPRING PLATE	

E. 押工関係 / Presser foot mechanism / Stoffdrückerfuß /
 Mécanisme du pied presseur / Mecanismo del prensa telas

061
062

35-1

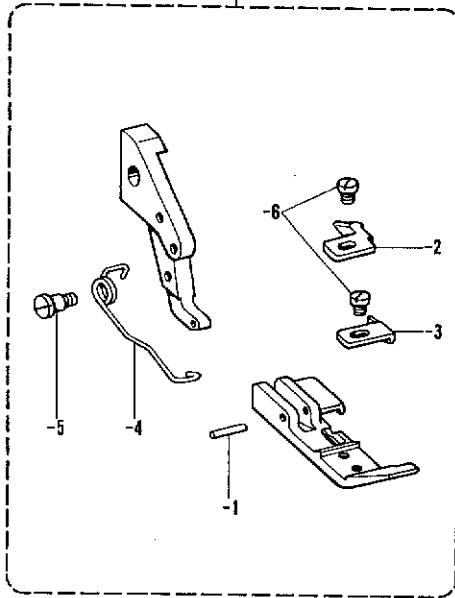

063
064

35-2

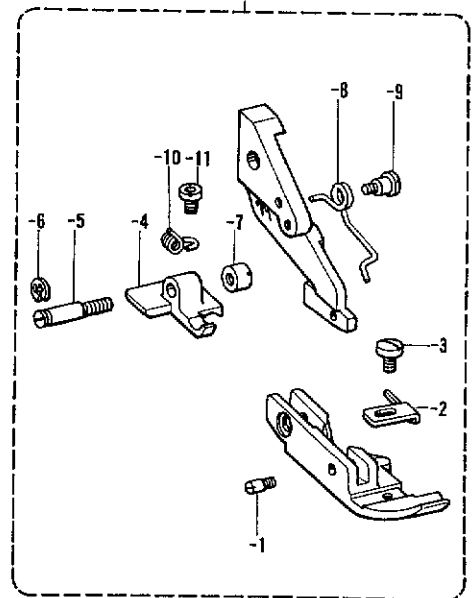

065
066,

087

(国内のみ
ONLY
FOR EXPORT)

35-3

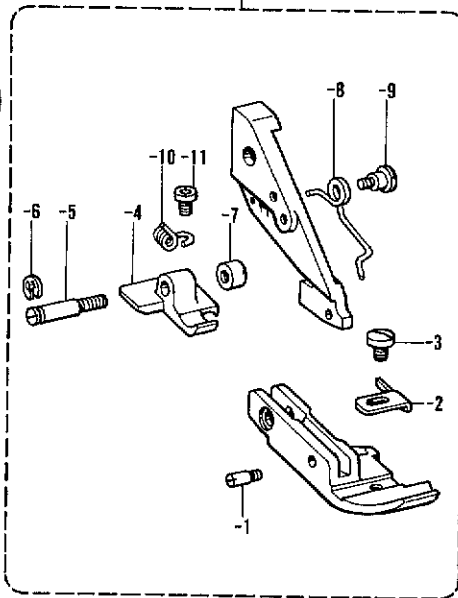

067

35-4

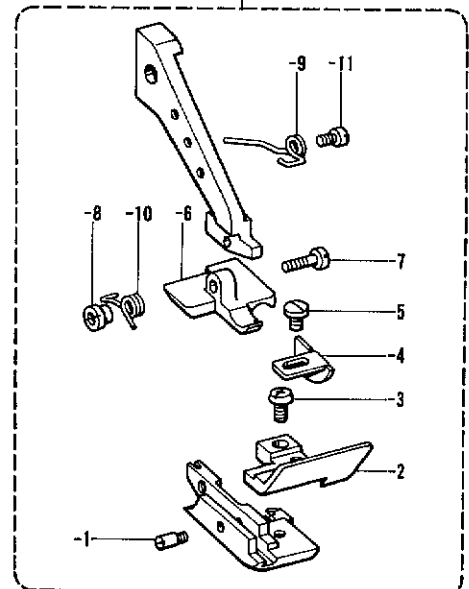

069

35-5

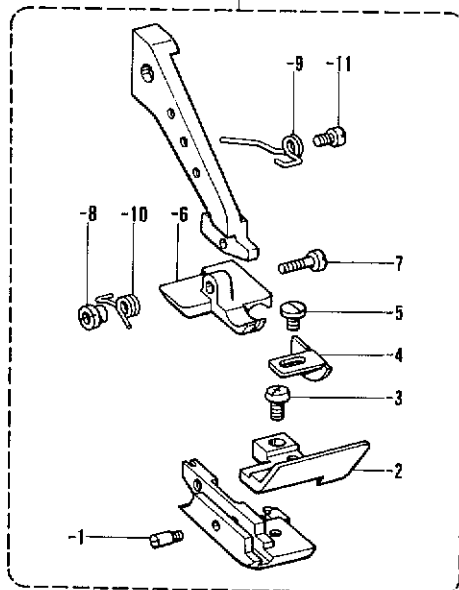

E. 押工関係/Presser foot mechanism/Stoffdrückerfuß/
 Mécanisme du pied presseur/Mecanismo del prensa telas

REF.NO.	CODE	Q'TY	ヒンメイ	NAME OF PARTS	RMKS
35-1	142250001	1	オサイ2Cクミ <061,062>	PRESSER FOOT ASSEMBLY (2C) <061,062>	
35-1-1	142243000	1	オサイピン	PIN	
35-1-2	142244001	1	ツメ3C	STITCH TONGUE (3C)	
35-1-3	142245001	1	オサイF3C	CHIP GUARD (FRONT)(3C)	
35-1-4	142246001	1	オサイネジ"リハ"ネ3C	SPRING (3C)	
35-1-5	142247001	1	タ"ンネジ"	STUD SCREW	
35-1-6	S01295001	2	シメネジ"2.38X3.5	SCREW 2.38X3.5	
35-2	146871101	1	オサイクミ <063,064>	PRESSER FOOT ASSEMBLY <063,064>	
35-2-1	146865001	1	オサイFシタササイネジ"	SCREW	
35-2-2	145147001	1	オサイF	PRESSER FOOT (FRONT)	
35-2-3	105288001	1	シメネジ"2.38	SCREW 2.38	
35-2-4	149260001	1	オサイB	PRESSER FOOT (REAR)	
35-2-5	149261001	1	オサイBササイネジ"	SCREW	
35-2-6	048025342	1	トメワE2.5	STOP RING E2.5	
35-2-7	149262001	1	マルナツト3.18	NUT 3.18	
35-2-8	146869001	1	オサイFシタネジ"リハ"ネ	SPRING	
35-2-9	146901001	1	タ"ンネジ"3.18	STUD SCREW 3.18	
35-2-10	146870001	1	オサイBオシハ"ネ	SPRING	
35-2-11	122771002	1	シメネジ"2.38	SCREW 2.38	
35-3	146874101	1	オサイクミ <065,066,087>	PRESSER FOOT ASSEMBLY <065,066>	
35-3-1	140270001	1	オサイFシタササイネジ"	SCREW	
35-3-2	145147001	1	オサイF	PRESSER FOOT (FRONT)	
35-3-3	105288001	1	シメネジ"2.38	SCREW 2.38	
35-3-4	149265001	1	オサイB	PRESSER FOOT (REAR)	
35-3-5	149266001	1	オサイBササイネジ"	SCREW	
35-3-6	048025342	1	トメワE2.5	STOP RING E2.5	
35-3-7	149262001	1	マルナツト3.18	NUT 3.18	
35-3-8	146869001	1	オサイFシタネジ"リハ"ネ	SPRING	
35-3-9	146901001	1	タ"ンネジ"3.18	STUD SCREW 3.18	
35-3-10	146870001	1	オサイBオシハ"ネ	SPRING	
35-3-11	122771002	1	シメネジ"2.38	SCREW 2.38	
35-4	146878001	1	オサイクミ <067>	PRESSER FOOT ASSEMBLY <067>	
35-4-1	140270001	1	オサイFシタササイネジ"	SCREW	
35-4-2	144777001	1	オサイU	PRESSER FOOT (UPPER)	
35-4-3	062660712	1	ナハ"コ318-40X7	SCREW 318X7	
35-4-4	144778001	1	オサイF	PRESSER FOOT (FRONT)	
35-4-5	105288001	1	シメネジ"2.38	SCREW 2.38	
35-4-6	146880001	1	オサイB	PRESSER FOOT (REAR)	
35-4-7	140272001	1	シメネジ"3.18	SCREW 3.18	
35-4-8	140273001	1	オサイBマルナツト	NUT	
35-4-9	140993001	1	オサイFネジ"リハ"ネ	SPRING	
35-4-10	140275001	1	オサイBネジ"リハ"ネ	SPRING	
35-4-11	140992001	1	オサイFハ"ネカケネジ"	SET SCREW	
35-5	144775001	1	オサイEクミ <069>	PRESSER FOOT ASSEMBLY (E) <069>	
35-5-1	140270001	1	オサイFシタササイネジ"	SCREW	
35-5-2	144777001	1	オサイU	PRESSER FOOT (UPPER)	
35-5-3	062660712	1	ナハ"コ318-40X7	SCREW 318X7	
35-5-4	144778001	1	オサイF	PRESSER FOOT (FRONT)	
35-5-5	105288001	1	シメネジ"2.38	SCREW 2.38	
35-5-6	140271001	1	オサイB	PRESSER FOOT (REAR)	
35-5-7	140272001	1	シメネジ"3.18	SCREW 3.18	
35-5-8	140273001	1	オサイBマルナツト	NUT	
35-5-9	140993001	1	オサイFネジ"リハ"ネ	SPRING	
35-5-10	140275001	1	オサイBネジ"リハ"ネ	SPRING	
35-5-11	140992001	1	オサイFハ"ネカケネジ"	SET SCREW	

E. 押工関係/Presser foot mechanism/Stoffdrückerfuß/
 Mécanisme du pied presseur/Mecanismo del prensa telas

071

35-6

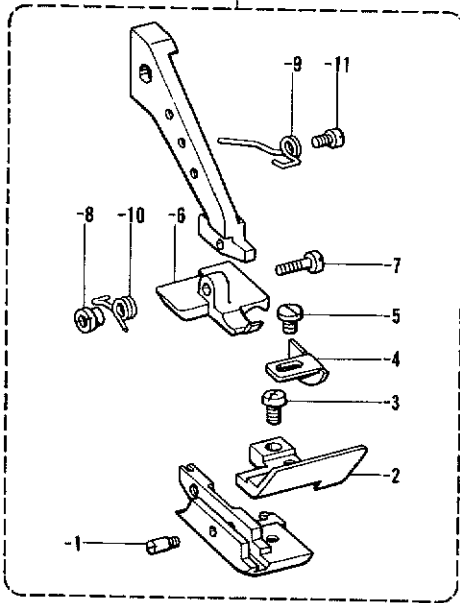

073
074

35-7

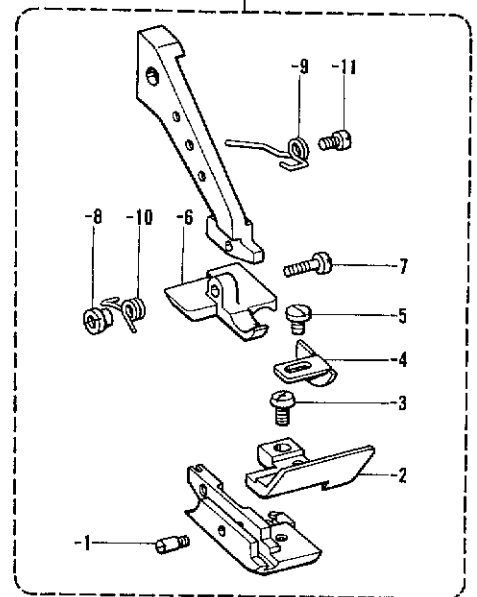

075
076

35-8

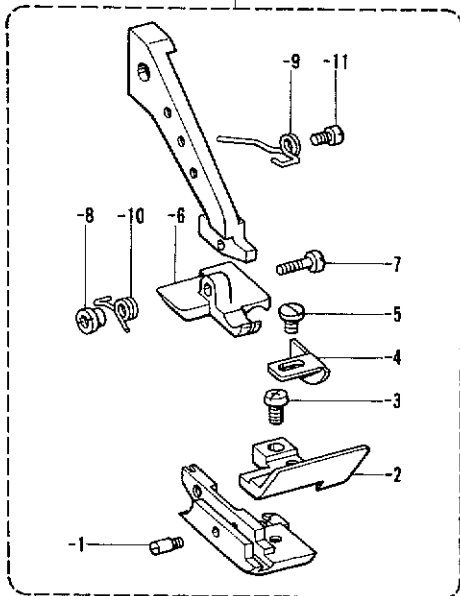

077

35-9

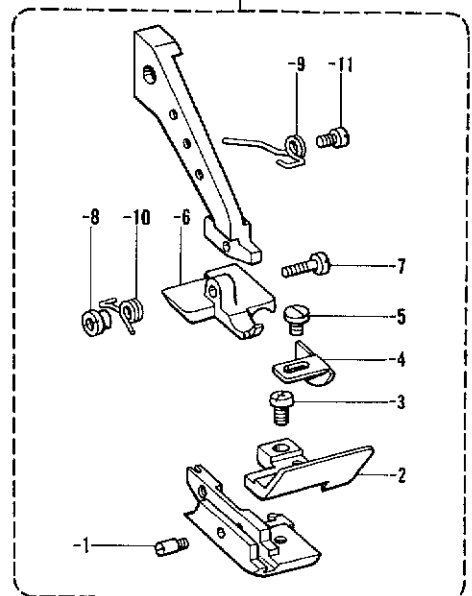

079

35-10

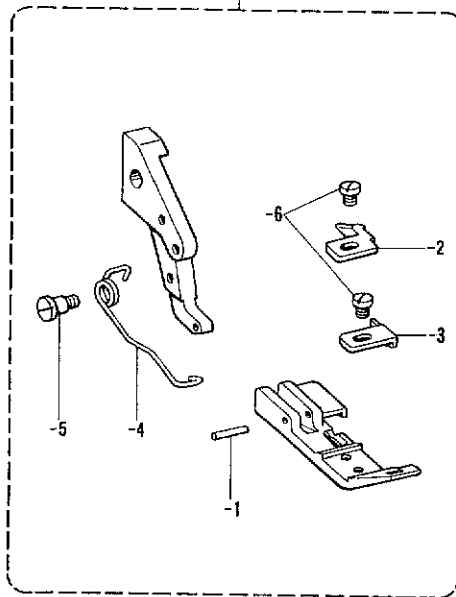

E. 押工関係/Presser foot mechanism/Stoffdrückerfuß/
Mécanisme du pied presseur/Mecanismo del prensa telas

REF.NO.	CODE	Q'TY	ヒンメイ	NAME OF PARTS	RMKS
35-6	146881001	1	オサイクミ <071>	PRESSER FOOT ASSEMBLY <071>	
35-6-1	140270001	1	オサIFシタササエネシ"	SCREW	
35-6-2	144777001	1	オサIU	PRESSER FOOT (UPPER)	
35-6-3	062660712	1	ナヘ"コ318-40X7	SCREW 318X7	
35-6-4	144778001	1	オサIF	PRESSER FOOT (FRONT)	
35-6-5	105288001	1	シメネシ"2.38	SCREW 2.38	
35-6-6	140991001	1	オサIB	PRESSER FOOT (REAR)	
35-6-7	140272001	1	シメネシ"3.18	SCREW 3.18	
35-6-8	140273001	1	オサIBマルナツト	NUT	
35-6-9	140993001	1	オサIFネシ"リハ"ネ	SPRING	
35-6-10	140275001	1	オサIBネシ"リハ"ネ	SPRING	
35-6-11	140992001	1	オサIFハ"ネカケネシ"	SET SCREW	
35-7	147785001	1	オサイクミ <073,074>	PRESSER FOOT ASSEMBLY <073,074>	
35-7-1	140270001	1	オサIFシタササエネシ"	SCREW	
35-7-2	144777001	1	オサIU	PRESSER FOOT (UPPER)	
35-7-3	062660712	1	ナヘ"コ318-40X7	SCREW 318X7	
35-7-4	144778001	1	オサIF	PRESSER FOOT (FRONT)	
35-7-5	105288001	1	シメネシ"2.38	SCREW 2.38	
35-7-6	147787001	1	オサIB	PRESSER FOOT (REAR)	
35-7-7	140272001	1	シメネシ"3.18	SCREW 3.18	
35-7-8	140273001	1	オサIBマルナツト	NUT	
35-7-9	140993001	1	オサIFネシ"リハ"ネ	SPRING	
35-7-10	140275001	1	オサIBネシ"リハ"ネ	SPRING	
35-7-11	140992001	1	オサIFハ"ネカケネシ"	SET SCREW	
35-8	147435001	1	オサイクミ <075,076>	PRESSER FOOT ASSEMBLY <075,076>	
35-8-1	140270001	1	オサIFシタササエネシ"	SCREW	
35-8-2	144777001	1	オサIU	PRESSER FOOT (UPPER)	
35-8-3	062660712	1	ナヘ"コ318-40X7	SCREW 318X7	
35-8-4	144778001	1	オサIF	PRESSER FOOT (FRONT)	
35-8-5	105288001	1	シメネシ"2.38	SCREW 2.38	
35-8-6	147488001	1	オサIB	PRESSER FOOT (REAR)	
35-8-7	140272001	1	シメネシ"3.18	SCREW 3.18	
35-8-8	140273001	1	オサIBマルナツト	NUT	
35-8-9	140993001	1	オサIFネシ"リハ"ネ	SPRING	
35-8-10	140275001	1	オサIBネシ"リハ"ネ	SPRING	
35-8-11	140992001	1	オサIFハ"ネカケネシ"	SET SCREW	
35-9	147437001	1	オサイクミ <077>	PRESSER FOOT ASSEMBLY <077>	
35-9-1	140270001	1	オサIFシタササエネシ"	SCREW	
35-9-2	144777001	1	オサIU	PRESSER FOOT (UPPER)	
35-9-3	062660712	1	ナヘ"コ318-40X7	SCREW 318X7	
35-9-4	144778001	1	オサIF	PRESSER FOOT (FRONT)	
35-9-5	105288001	1	シメネシ"2.38	SCREW 2.38	
35-9-6	147489001	1	オサIB	PRESSER FOOT (REAR)	
35-9-7	140272001	1	シメネシ"3.18	SCREW 3.18	
35-9-8	140273001	1	オサIBマルナツト	NUT	
35-9-9	140993001	1	オサIFネシ"リハ"ネ	SPRING	
35-9-10	140275001	1	オサIBネシ"リハ"ネ	SPRING	
35-9-11	140992001	1	オサIFハ"ネカケネシ"	SET SCREW	
35-10	148816001	1	オサイクミ <079>	PRESSER FOOT ASSEMBLY <079>	
35-10-1	142243000	1	オサEピン	PIN	
35-10-2	142244001	1	ツメ3C	STITCH TONGUE (3C)	
35-10-3	142245001	1	オサIF3C	CHIP GUARD (FRONT)(3C)	
35-10-4	142246001	1	オサEネシ"リハ"ネ3C	SPRING (3C)	
35-10-5	142247001	1	タ"ンネシ"	STUD SCREW	
35-10-6	S01295001	2	シメネシ"2.38X3.5	SCREW 2.38X3.5	

E. 押工関係/Presser foot mechanism/Stoffdrückerfuß/
 Mécanisme du pied presseur/Mecanismo del prensa telas

081

35-11

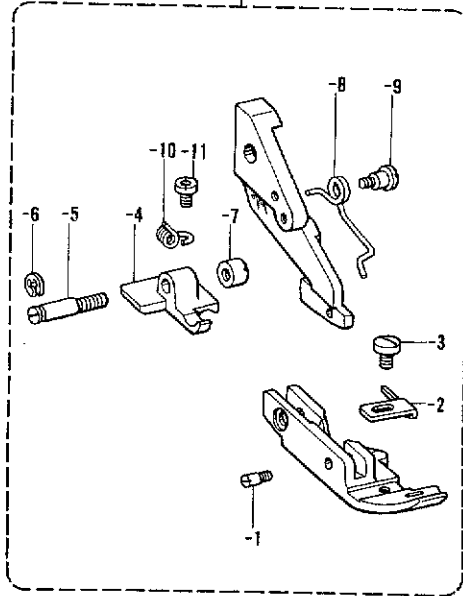

083
084

35-12

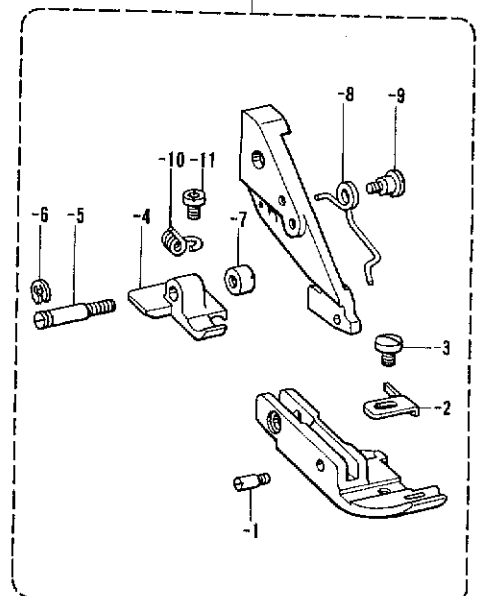

085

35-13

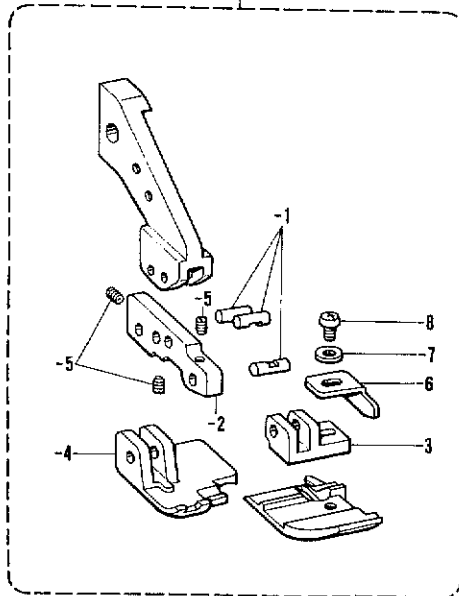

089
090

35-14

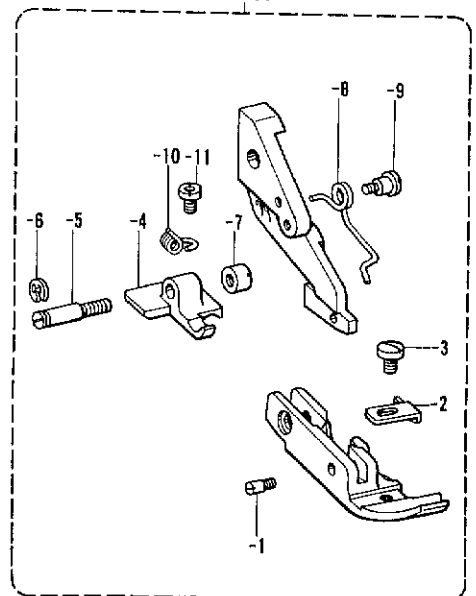

087

輸出のみ
ONLY
FOR EXPORT

092
093

35-15

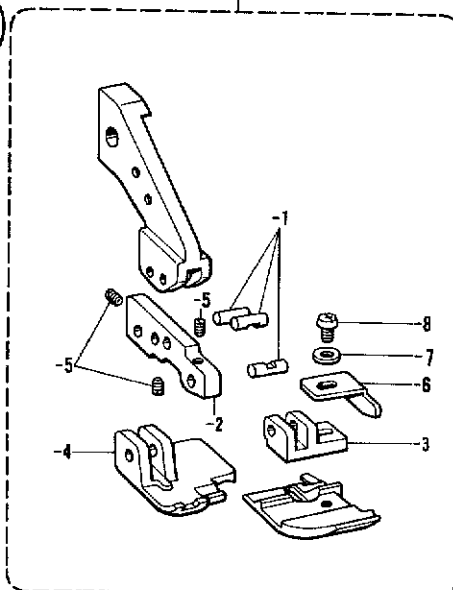

E. 押工関係/Presser foot mechanism/Stoffdrückerfuß/
 Mécanisme du pied presseur/Mecanismo del prensa telas

REF.NO.	CODE	Q'TY	ヒンメイ	NAME OF PARTS	RMKS
35-11	147950101	1	オサイクミ <081>	PRESSER FOOT ASSEMBLY <081>	
35-11-1	146865001	1	オサエフシタササエネジ"	SCREW	
35-11-2	145147001	1	オサエフ	PRESSER FOOT (FRONT)	
35-11-3	105288001	1	シメネジ"2.38	SCREW 2.38	
35-11-4	149260001	1	オサエB	PRESSER FOOT (REAR)	
35-11-5	149261001	1	オサエBササエネジ"	SCREW	
35-11-6	048025342	1	トメフE2.5	STOP RING E2.5	
35-11-7	149262001	1	マルナツト3.18	NUT 3.18	
35-11-8	146869001	1	オサエフシタネジ"リハ"ネ	SPRING	
35-11-9	146901001	1	タ"ンネジ"3.18	STUD SCREW 3.18	
35-11-10	146870001	1	オサエBオシハ"ネ	SPRING	
35-11-11	122771002	1	シメネジ"2.38	SCREW 2.38	
35-12	148405101	1	オサイクミ <083,084>	PRESSER FOOT ASSEMBLY <083,084>	
35-12-1	140270001	1	オサエフシタササエネジ"	SCREW	
35-12-2	145147001	1	オサエフ	PRESSER FOOT (FRONT)	
35-12-3	105288001	1	シメネジ"2.38	SCREW 2.38	
35-12-4	149265001	1	オサエB	PRESSER FOOT (REAR)	
35-12-5	149266001	1	オサエBササエネジ"	SCREW	
35-12-6	048025342	1	トメフE2.5	STOP RING E2.5	
35-12-7	149262001	1	マルナツト3.18	NUT 3.18	
35-12-8	146869001	1	オサエフシタネジ"リハ"ネ	SPRING	
35-12-9	146901001	1	タ"ンネジ"3.18	STUD SCREW 3.18	
35-12-10	146870001	1	オサエBオシハ"ネ	SPRING	
35-12-11	122771002	1	シメネジ"2.38	SCREW 2.38	
35-13	148979101	1	オサイクミ <085>	PRESSER FOOT ASSEMBLY <085>	
35-13-1	S01375001	3	オサエヒンジ"シ"ク	HINGE SHAFT	
35-13-2	S01373001	1	オサエFBササエ	PRESSER FOOT SUPPORTER (FRONT,REAR)	
35-13-3	S01385001	1	オサエフシタササエ	PRESSER FOOT LOWER SUPPORTER (FRONT)	
35-13-4	S01371001	1	オサエB	PRESSER FOOT (REAR)	
35-13-5	S01374001	3	トメネジ"2.38クホ"ミ	SCREW 2.38	
35-13-6	149143001	1	オサエF	PRESSER FOOT (FRONT)	
35-13-7	025030232	1	ヒラサ"カ"ネチユウ3	WASHER 3	
35-13-8	062660612	1	ナヘ"コ318-40X6	SCREW 318X6	
35-14	147370101	1	オサイクミ <089,090>	PRESSER FOOT ASSEMBLY <089,090>	
35-14-1	146865001	1	オサエフシタササエネジ"	SCREW	
35-14-2	147371001	1	オサエF	PRESSER FOOT (FRONT)	
35-14-3	105288001	1	シメネジ"2.38	SCREW 2.38	
35-14-4	149260001	1	オサエB	PRESSER FOOT (REAR)	
35-14-5	149261001	1	オサエBササエネジ"	SCREW	
35-14-6	048025342	1	トメフE2.5	STOP RING E2.5	
35-14-7	149262001	1	マルナツト3.18	NUT 3.18	
35-14-8	146869001	1	オサエフシタネジ"リハ"ネ	SPRING	
35-14-9	146901001	1	タ"ンネジ"3.18	STUD SCREW 3.18	
35-14-10	146870001	1	オサエBオシハ"ネ	SPRING	
35-14-11	122771002	1	シメネジ"2.38	SCREW 2.38	
35-15	148013101	1	オサイクミ <092,093>	PRESSER FOOT ASSEMBLY <092,093,087>	
35-15-1	S01375001	3	オサエヒンジ"シ"ク	HINGE SHAFT	
35-15-2	S01373001	1	オサエFBササエ	PRESSER FOOT SUPPORTER (FRONT,REAR)	
35-15-3	S01372001	1	オサエフシタササエ	PRESSER FOOT LOWER SUPPROTER (FRONT)	
35-15-4	S01371001	1	オサエB	PRESSER FOOT (REAR)	
35-15-5	S01374001	3	トメネジ"2.38クホ"ミ	SCREW 2.38	
35-15-6	148020001	1	オサエF	PRESSER FOOT (FRONT)	
35-15-7	025030232	1	ヒラサ"カ"ネチユウ3	WASHER 3	
35-15-8	062660612	1	ナヘ"コ318-40X6	SCREW 318X6	

E. 押工関係/Presser foot mechanism/Stoffdrückerfuß/
 Mécanisme du pied presseur/Mecanismo del prensa telas

094

(輸出のみ
 ONLY
 FOR EXPORT)

35-16

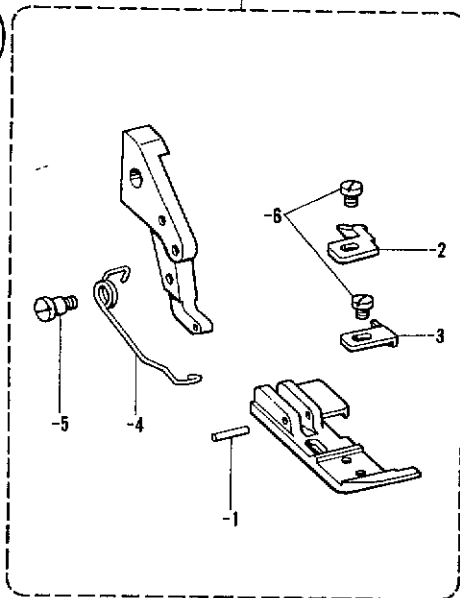

094

(国内のみ
 ONLY FOR
 DOMESTIC)

35-17

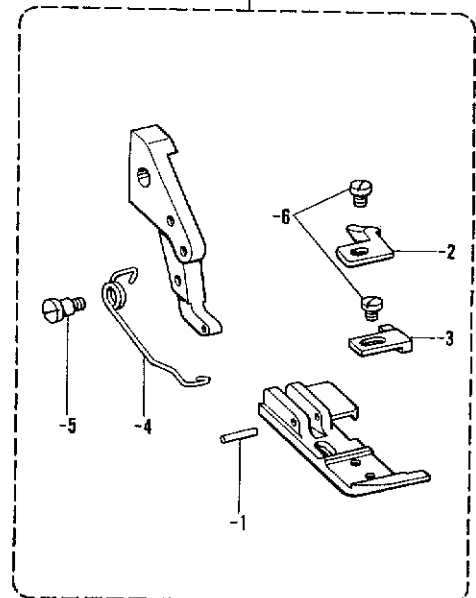

095

35-18

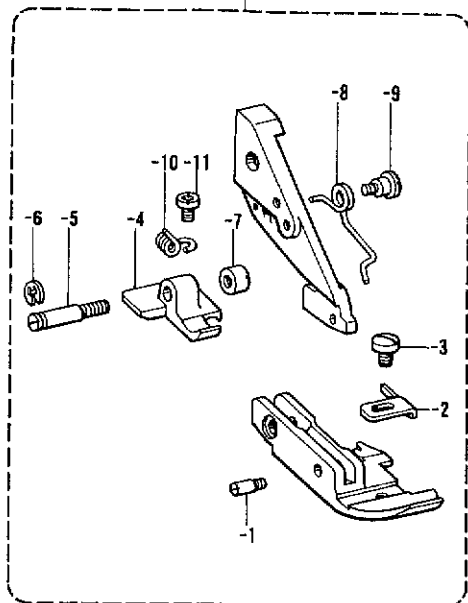

096

(国内用
 ONLY FOR
 DOMESTIC)

35-19

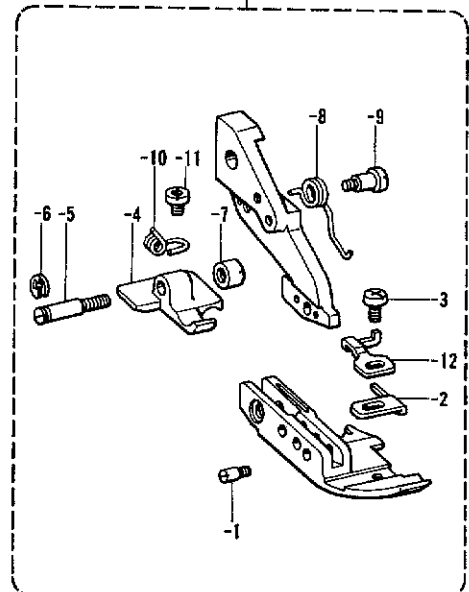

097

(国内用
 ONLY FOR
 DOMESTIC)

35-20

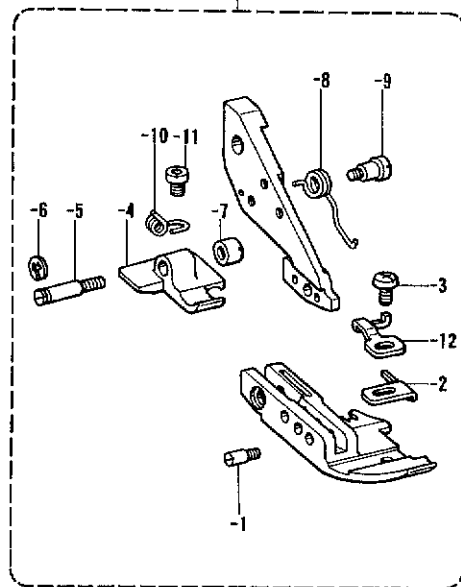

E. 押工関係/Presser foot mechanism/Stoffdrückerfuß/
Mécanisme du pied presseur/Mecanismo del prensa telas

REF.NO.	CODE	Q'TY	ヒンメイ	NAME OF PARTS	RMKS
35-16	151461001	1	-----	PRESSER FOOT ASSEMBLY (7C) <094>	
35-16-1	142243000	1	-----	PIN	
35-16-2	142244001	1	-----	STITCH TONGUE (3C)	
35-16-3	142245001	1	-----	CHIP GUARD (3C)	
35-16-4	151466001	1	-----	SPRING (7C)	
35-16-5	142247001	1	-----	STUD SCREW	
35-16-6	S01295001	2	-----	SCREW 2.38X3.5	
35-17	151462001	1	オサエ7Cクミ <094>	-----	
35-17-1	142243000	1	オサエピン	-----	
35-17-2	151464001	1	ツメ7C	-----	
35-17-3	151465001	1	オサエF	-----	
35-17-4	151466001	1	オサエネジ"リハ"ネ7C	-----	
35-17-5	142247001	1	タ"ンネジ"	-----	
35-17-6	S01295001	2	シメネジ"2.38X3.5	-----	
35-18	156507001	1	オサエクミ <095>	PRESSER FOOT ASSEMBLY <095>	
35-18-1	140270001	1	オサエFシタササエネジ"	SCREW	
35-18-2	145147001	1	オサエF	PRESSER FOOT (FRONT)	
35-18-3	105288001	1	シメネジ"2.38	SCREW 2.38	
35-18-4	149265001	1	オサエB	PRESSER FOOT (REAR)	
35-18-5	149266001	1	オサエBササエネジ"	SCREW	
35-18-6	048025342	1	トメワE2.5	STOP RING E2.5	
35-18-7	149262001	1	マルナツト3.18	NUT 3.18	
35-18-8	146869001	1	オサエFシタネジ"リハ"ネ	SPRING	
35-18-9	146901001	1	タ"ンネジ"3.18	STUD SCREW 3.18	
35-18-10	146870001	1	オサエBオシハ"ネ	SPRING	
35-18-11	122771002	1	シメネジ"2.38	SCREW 2.38	
35-19	S01762101	1	オサエクミ <096>	-----	
35-19-1	146865001	2	オサエFシタササエネジ"	-----	
35-19-2	S01950001	1	オサエF	-----	
35-19-3	060630412	1	ハ"イント"238-56X4	-----	
35-19-4	156065001	1	オサエB	-----	
35-19-5	149261001	1	オサエBササエネジ"	-----	
35-19-6	048025342	1	トメワE2.5	-----	
35-19-7	149262001	1	マルナツト3.18	-----	
35-19-8	S09565001	1	オサエFシタネジ"リハ"ネ	-----	
35-19-9	155103001	1	タ"ンネジ"3.18	-----	
35-19-10	146870001	1	オサエBオシハ"ネ	-----	
35-19-11	122771002	1	シメネジ"2.38	-----	
35-19-12	S01951001	1	テーブ"アンナイ	-----	
35-20	S01759101	1	オサエクミ <097>	-----	
35-20-1	140270001	2	オサエFシタササエネジ"	-----	
35-20-2	S01950001	1	オサエF	-----	
35-20-3	060630412	1	ハ"イント"238-56X4	-----	
35-20-4	156069001	1	オサエB	-----	
35-20-5	149266001	1	オサエBササエネジ"	-----	
35-20-6	048025342	1	トメワE2.5	-----	
35-20-7	149262001	1	マルナツト3.18	-----	
35-20-8	S09565001	1	オサエFシタネジ"リハ"ネ	-----	
35-20-9	155103001	1	タ"ンネジ"3.18	-----	
35-20-10	146870001	1	オサエBオシハ"ネ	-----	
35-20-11	122771002	1	シメネジ"2.38	-----	
35-20-12	S01951001	1	テーブ"アンナイ	-----	

F. 送り関係 / Feed mechanism / Transportvorrichtung /
 Mécanisme de l'entraînement / Mecanismo de la alimentación

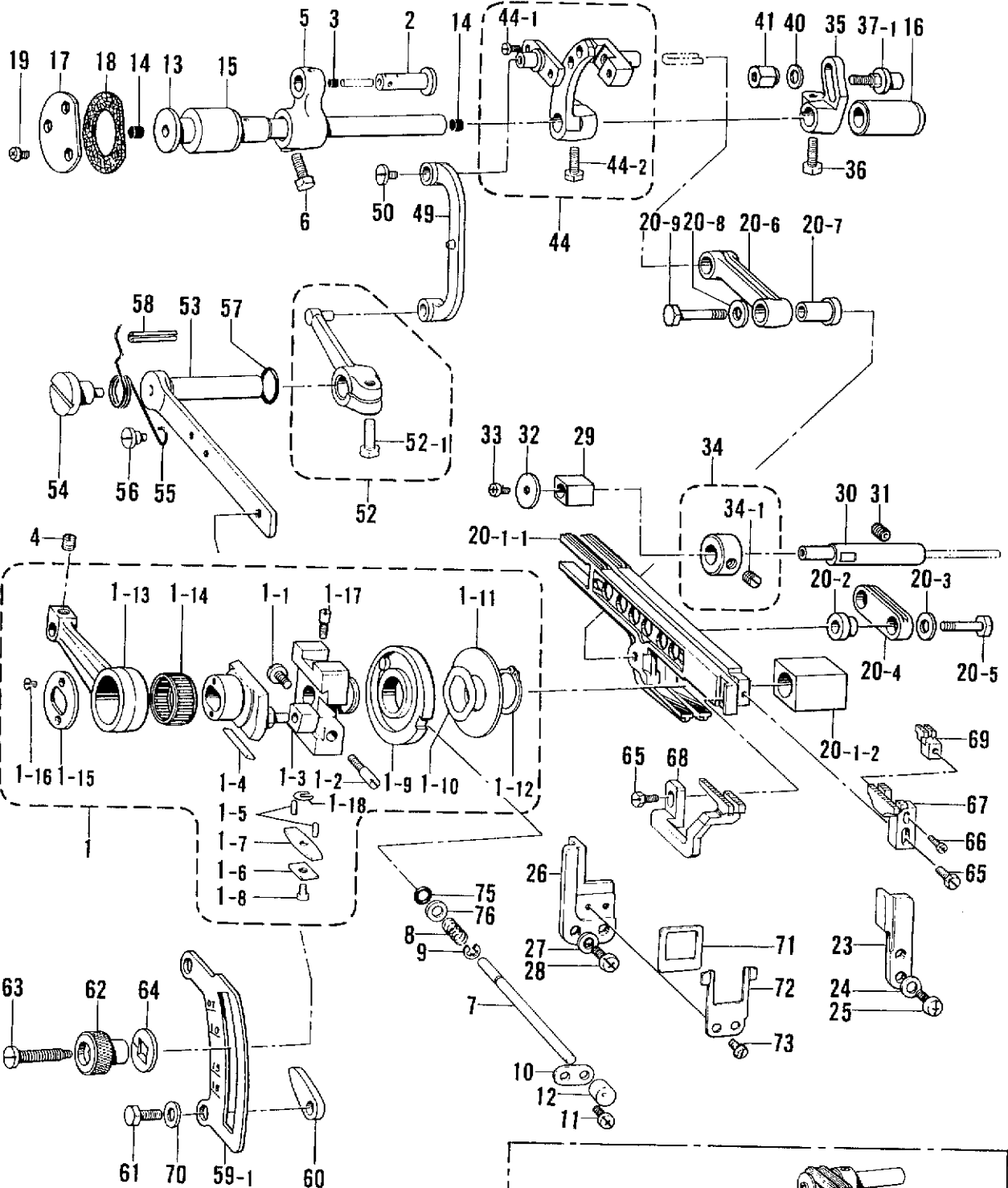

国内用 / FOR DOMESTIC
 096
 097



37-2



59-2

067
 069
 071
 073
 074
 075
 076
 077

59-3

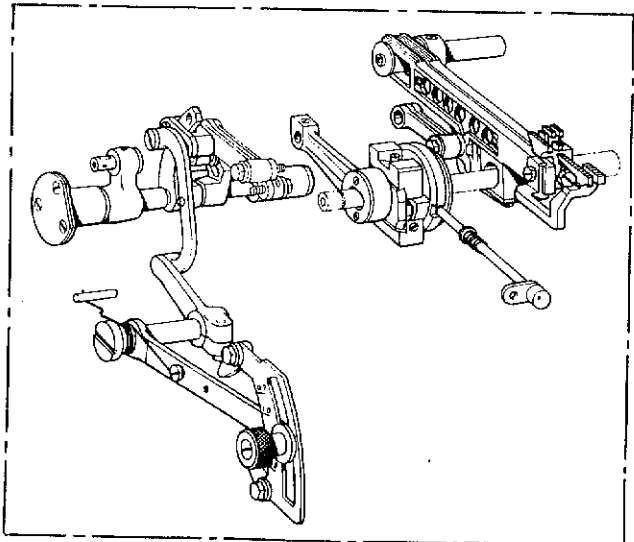

F. 送り関係/Feed mechanism/Transportvorrichtung/
Mécanisme de l'entraînement/Mecanismo de la alimentación

REF.NO.	CODE	Q'TY	ヒンメイ	NAME OF PARTS	RMKS
1	146528001	1	ヘンシンリンクミ	ECCENTRIC WHEEL ASSEMBLY	
1-1	107093002	1	シメネジ"4.37	SCREW 4.37	
1-2	145663001	1	トメネジ"4.37	SCREW 4.37	
1-3	140165001	1	チヨウセツヒンカクコマ	SLIDE BLOCK	
1-4	146401001	1	ジ"フ"	GIB	
1-5	146402001	2	ジ"フ"オサエヒ"ン	GIB HOLDER PIN	
1-6	146403001	1	ジ"フ"オサエイタハ"ネS	GIB HOLDER SPRING PLATE (SMALL)	
1-7	146404001	1	ジ"フ"オサエイタハ"ネL	GIB HOLDER SPRING PLATE (LARGE)	
1-8	062660512	1	ナヘ"コネジ"318-40X5	SCREW 318X5	
1-9	144053001	1	ヘンシンチヨウセツカムクミ	ECCENTRIC WHEEL ADJUSTING CAM	
1-10	144055001	1	ナミハ"ネ	WAVE SPRING	
1-11	146529001	1	サ"カ"ネ	WASHER	
1-12	048150143	1	トメワシ"クヨウC15	STOP RING C15	
1-13	146530001	1	オクリロツト"	FEED ROD	
1-14	146531001	1	ニートルシ"クウケ20	NEEDLE ROLLER BEARING 20	
1-15	140176001	1	オクリロツト"オサエイタ	FEED ROD PRESSER PLATE	
1-16	117517003	2	サラネジ"2.38	SCREW 2.38	
1-17	100025002	2	シメネジ"4.76	SCREW 4.76	
1-18	S05721003	1	スペ"ーサ	SPACER	
2	146532001	1	オクリロツト"ヒ"ン	FEED ARM PIN	
3	140326001	1	ゴムセン	OIL CAP	
4	100251001	1	トメネジ"6.35	SCREW 6.35	
5	146533001	1	オクリウデ"	FEED ARM	
6	017771612	1	ボ"ルト6.35X16	BOLT 6.35X16	
7	146534001	1	オクリチヨウセツホ"タンシ"ク	FEED ADJUSTING SHAFT	
8	S11072001	1	ホ"タンシ"クハ"ネ	SPRING	
9	048040342	1	トメワE4	STOP RING E4	
10	146536001	1	オクリホ"タンシ"クササE	SUPPORTER FOR FEED ADJUSTING PLATE	
11	062670612	1	ナヘ"コ357-40X6	SCREW 357X6	
12	146537000	1	キャツプ	CAP	
13	146538001	1	オクリシ"ク	FEED SHAFT	
14	140327001	2	ゴムセン	OIL CAP	
15	146539000	1	オクリシ"クメタルL	FEED SHAFT BUSHING (LEFT)	
16	146540000	1	オクリシ"クメタルR	FEED SHAFT BUSHING (RIGHT)	
17	140188004	1	オクリシ"クメタルLフタ	COVER FOR FEED SHAFT BUSHING (LEFT)	
18	140187000	1	ハ"ツキン	PACKING	
19	062670812	3	ナヘ"コ357-40X8	SCREW 357X8	
20	159475001	1	オクリタ"イカクコマリンククミ	FEED BAR SLIDE BLOCK LINK ASSEMBLY	
20-1	146541001	1	オクリタ"イカクコ"マクミ	FEED BAR SLIDE BLOCK ASSEMBLY	
20-1-1	147773001	1	オクリタ"イクミ	FEED BAR ASSEMBLY	
20-1-2	146544000	1	シ"ヨウケ"オクリカクコ"マ	FEED LIFTING SLIDE BLOCK	
20-2	140207001	1	シユオクリリンクフ"シユ	MAIN FEED LINK BUSHING	
20-3	140208001	1	サ"カ"ネ	WASHER	
20-4	140209001	1	シユオクリリンク	MAIN FEED LINK	
20-5	140210001	1	シユオクリリンクシ"クS	MAIN FEED LINK SHAFT (SMALL)	
20-6	146554001	1	サト"ウオクリリンク	DIFFERENTIAL FEED LINK	
20-7	146555001	1	サト"ウオクリリンクフ"シユ	DIFFERENTIAL FEED LINK BUSHING	
20-8	140208001	1	サ"カ"ネ	WASHER	
20-9	140217001	1	オクリリンクシ"クL	FEED LINK SHAFT (LARGE)	
23	148174000	1	オクリタ"イアンナイR	FEED BAR GUIDE (RIGHT)	
24	100645003	2	サ"カ"ネ	WASHER	
25	062681012	2	ナヘ"コ437-40X10	SCREW 437X10	
26	149888000	1	オクリタ"イアンナイL	FEED BAR GUIDE (LEFT)	
27	100645003	2	サ"カ"ネ	WASHER	
28	062681012	2	ナヘ"コ437-40X10	SCREW 437X10	
29	146547000	1	オクリタ"イカクコ"マ	FEED BAR SLIDE BLOCK	
30	146548101	1	オクリタ"イカクコ"マシ"ク	FEED BAR SLIDE BLOCK SHAFT	
31	014770622	1	アナトメネジ"6.35クホ"ミ	SCREW 6.35	
32	146549001	1	オクリタ"イカクコ"マアテイタ	PLATE FOR SLIDE BLOCK	
33	062680712	1	ナヘ"コ437-40X7	SCREW 437X7	
34	181969003	1	セツトカラ"クミ	SET COLLAR ASSEMBLY	
34-1	101706001	2	トメネジ"6.35	SCREW 6.35	

F. 送り関係/Feed mechanism/Transportvorrichtung/
 Mécanisme de l'entraînement/Mecanismo de la alimentación

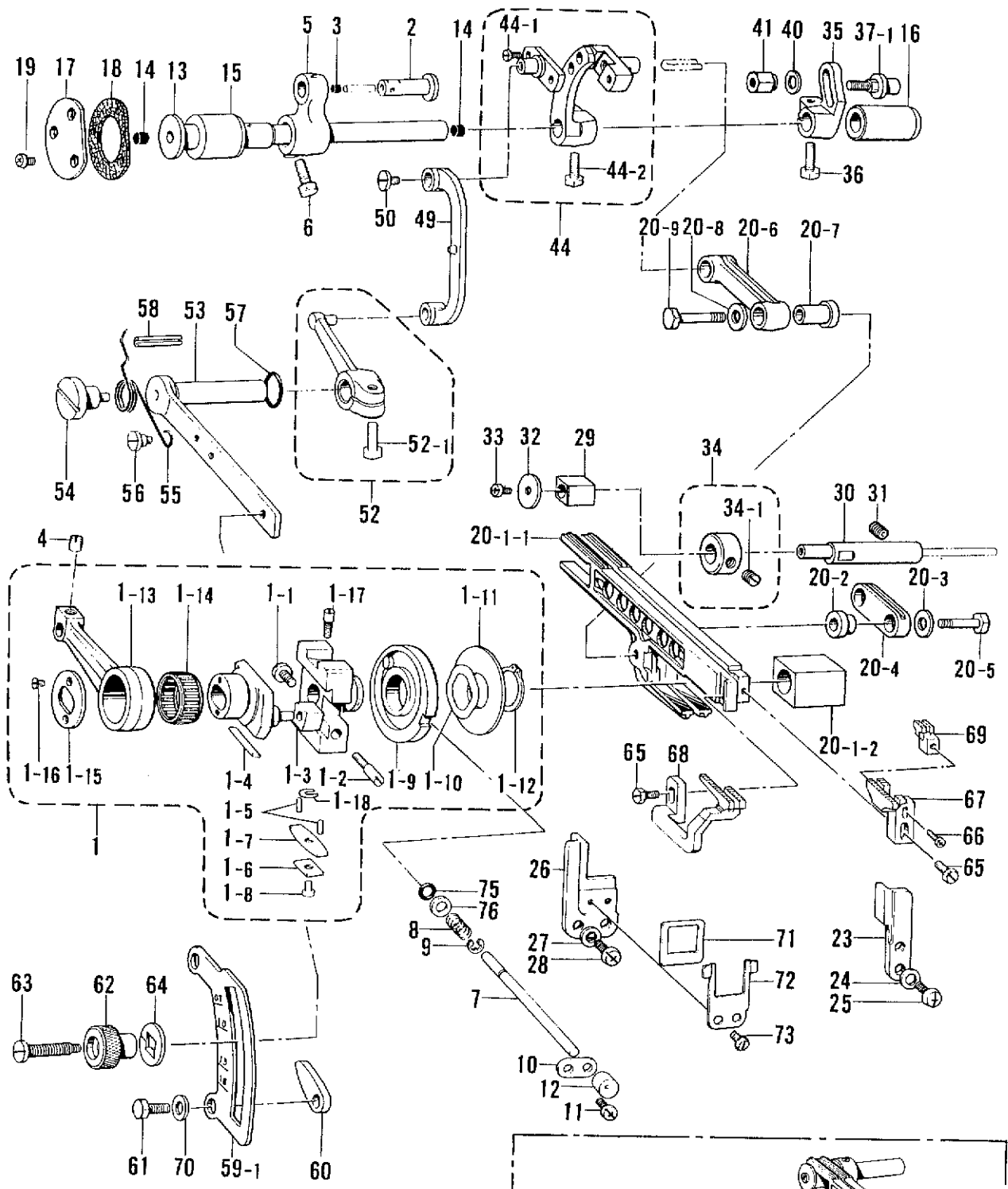

国内用 / FOR DOMESTIC
 096
 097

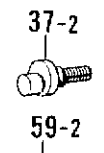

067
 069
 071
 073
 074
 075
 076
 077

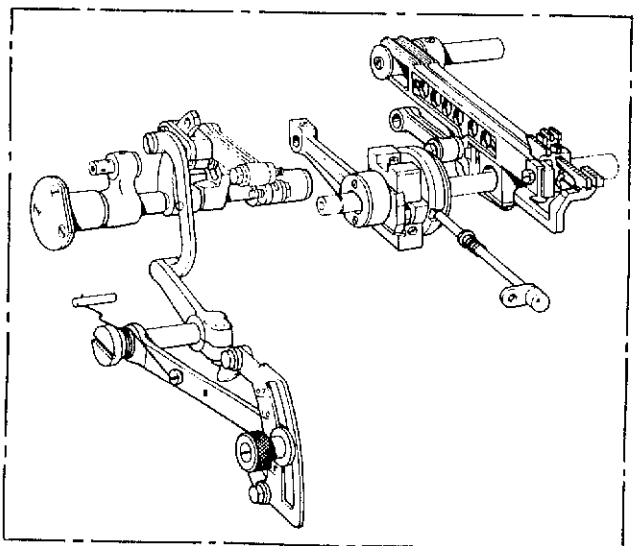
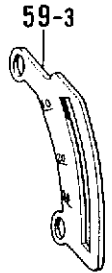

F. 送り関係/Feed mechanism/Transportvorrichtung/
Mécánisme de l'entraînement/Mecanismo de la alimentación

REF.NO.	CODE	Q'TY	ヒンメイ	NAME OF PARTS	RMKS
35	140205001	1	シユオクリウテ"	MAIN FEED ARM	
36	017771412	1	ボ"ルト6.35X14	BOLT 6.35X14	
37-1	143564001	1	シユオクリジ"ク	MAIN FEED SHAFT (LARGE)	
37-2	144068001	1	シユオクリジ"ク	-----	
40	113431002	1	サ"カ"ネ	WASHER	
41	143565001	1	ナツト4.76	NUT 4.76	
44	146550001	1	サト"ウオクリウテ"クミ	DIFFERENTIAL FEED ARM ASSEMBLY	
44-1	062660712	2	ナヘ"コ318-40X7	SCREW 318X7	
44-2	017771412	1	ボ"ルト6.35X14	BOLT 6.35X14	
49	146556001	1	サト"ウリンク	DIFFERENTIAL FEED ADJUSTING LINK	
50	148834001	1	シメネジ"3.57	SCREW 3.57	
52	146914001	1	リンクレハ"ーネジ"ツキ	LINK LEVER ASSEMBLY WITH SCREW	
52-1	017771412	1	ボ"ルト6.35X14	BOLT 6.35X14	
53	146558001	1	サト"ウチヨウセツレハ"ー	DIFFERENTIAL FEED ADJUSTING LEVER	
54	146559001	1	タ"ンネジ"5.56	STUD SCREW 5.56	
55	146560101	1	レハ"ーハ"ネ	LEVER SPRING	
56	100294002	1	タ"ンネジ"4.76	STUD SCREW 4.76	
57	109203001	1	Oリング"	O RING	
58	047502242	1	スプリング"ピンAW5	SPRING PIN AW5	
59-1	146561001	1	サト"ウリヨウメモリアタ	DIFFERENTIAL STITCH CONTROL	
59-2	146742001	1	サト"ウリヨウメモリアタ	-----	
59-3	146562001	1	サト"ウリヨウメモリアタ	DIFFERENTIAL STITCH CONTROL	
60	146563001	2	チヨウセツレハ"ーストツハ"	STOPPER FOR DIFFERENTIAL STITCH CONTROL	
61	017771612	2	ボ"ルト6.35X16	BOLT 6.35X16	
62	146564001	1	セツトネジ"ツマミ	KNOB	
63	146565001	1	セツトネジ"	SET SCREW	
64	146566001	1	サ"カ"ネ	WASHER	
65	117516001	2	ボ"ルト4.37	BOLT 4.37	
66	062630812	1	ナヘ"コ238-56X8	SCREW 238X8	
67	*	1	シユオクリハ"	MAIN FEED DOG	
68	*	1	サト"ウオクリハ"	DIFFERENTIAL FEED DOG	
69	*	1	ホジ"ヨオクリハ"	CHAIN FEED DOG	
70	025770232	2	ヒラサ"カ"ネチユウ6.35	WASHER 6.35	
71	149886000	1	ホ"ウシ"ンイタ	FRAGMENT PROTECTOR PLATE	
72	149887001	1	ホ"ウシ"ンイタササエ	FRAGMENT PROTECTOR PLATE SUPPORTER	
73	S01297001	2	シメネジ"3.57X3.5	SCREW 3.57X3.5	
75	118770001	1	ハ"ツキン	PACKING	
76	113431002	1	サ"カ"ネ	WASHER	

G. 上メス・下メス関係/Knife mechanism/Messer/Mécanisme du couteau/Mecanismo del cuchilla

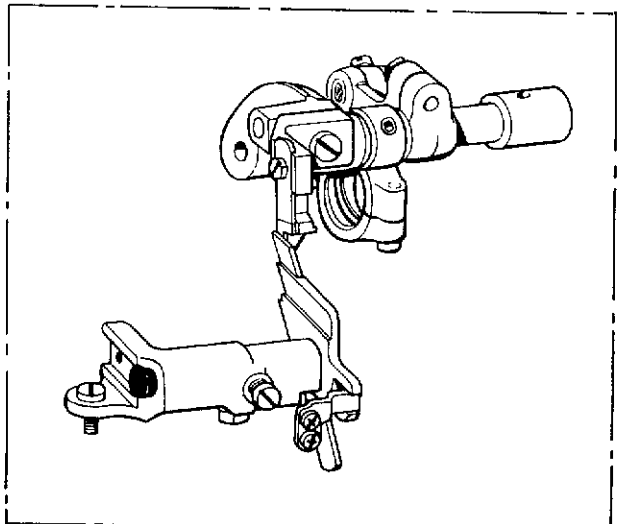
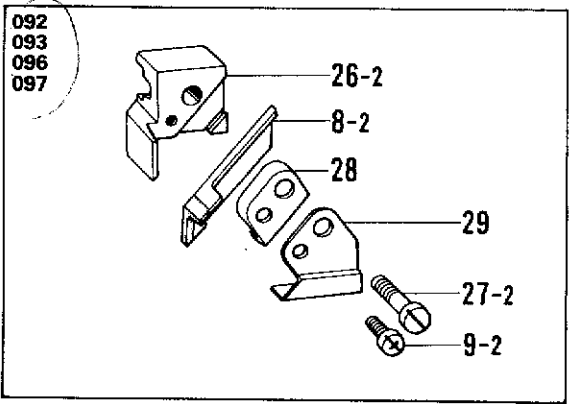
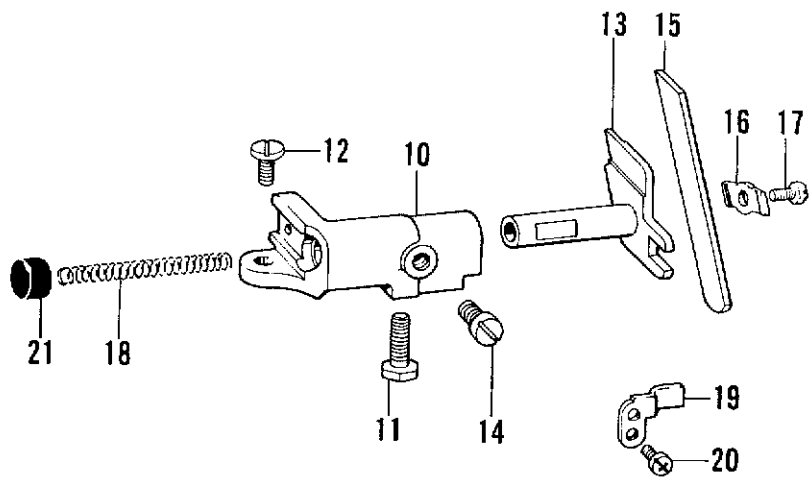
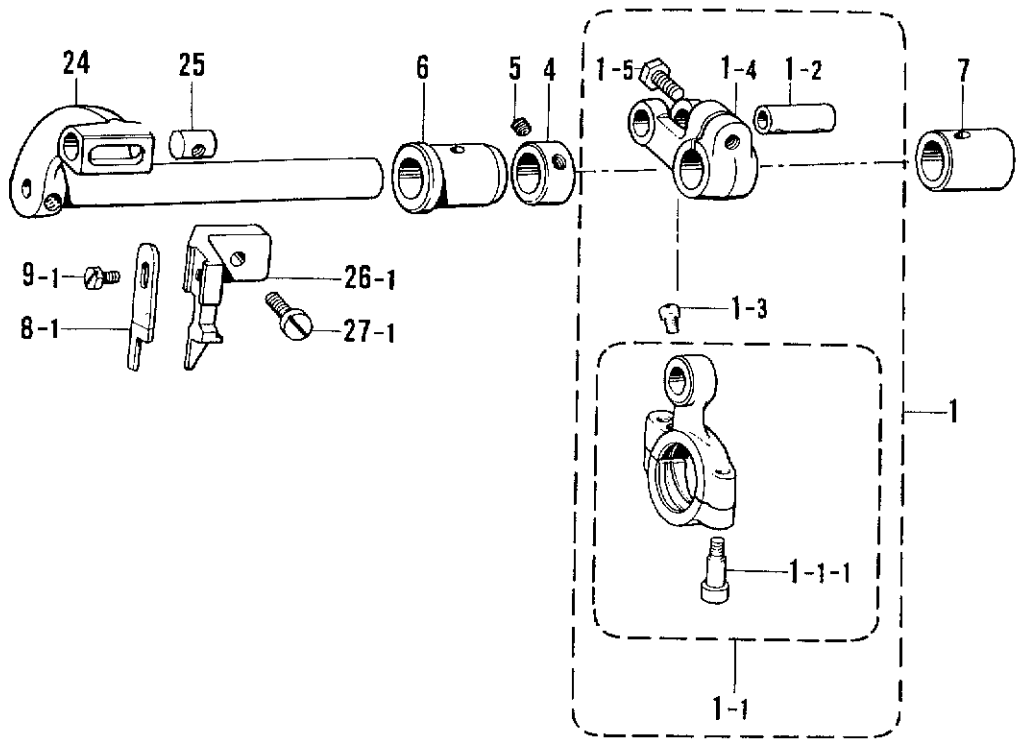

G. 上メス・下メス関係 / Knife mechanism / Messer / Mécanisme du couteau / Mecanismo del cuchilla

REF.NO.	CODE	Q'TY	ヒンメイ	NAME OF PARTS	RMKS
1	148427001	1	ウフメスクランクロッド"クミ	UPPER KNIFE DRIVING ROD ASSEMBLY	
1-1	S01223001	1	ウフメスロッド"ネシ"ツキ	UPPER KNIFE ROD WITH SCREW	
1-1-1	148425001	2	アナボ"ルト4.37X14	BOLT 4.37X14	
1-2	140232001	1	ウフメスクランクロッド"ヒン	CRANK ROD PIN	
1-3	100366001	1	マルヒラトメネシ"4.37	SCREW 4.37	
1-4	140233001	1	ウフメスクランクシ"クウテ"	UPPER KNIFE DRIVING LEVER	
1-5	017771612	1	ボ"ルト6.35X16	BOLT 6.35X16	
4	146581001	1	セツトカラー	SET COLLAR	
5	100260001	2	トメネシ"5.95	SCREW 5.95	
6	140235000	1	ウフメスサト"ウウテ"メタルL	UPPER KNIFE DRIVING ARM BUSHING (LEFT)	
7	144117000	1	ウフメスサト"ウウテ"メタルR	UPPER KNIFE DRIVING ARM BUSHING (RIGHT)	
8-1	144074000	1	ウフメス	UPPER KNIFE	
8-2	148815001	1	ウフメス	UPPER KNIFE	
9-1	144075001	1	ボ"ルト3.57	BOLT 3.57	
9-2	062671012	1	ナヘ"コ357-40X10	SCREW 357X10	
10	146582001	1	シタメストリツケタ"イササエ	LOWER KNIFE HOLDER SUPPORTER	
11	017771412	1	ボ"ルト6.35X14	BOLT 6.35X14	
12	107407003	1	シメネシ"4.37	SCREW 4.37	
13	146583001	1	シタメストリツケタ"イ	LOWER KNIFE HOLDER	
14	102627001	1	アタマツキトメネシ"6.35	SCREW 6.35	
15	112436001	1	シタメス	LOWER KNIFE	
16	117515001	1	シタメスオサエ	LOWER KNIFE PRESSER PLATE	
17	117516001	1	ボ"ルト4.37	BOLT 4.37	
18	146584001	1	シタメストリツケタ"イハ"ネ	LOWER KNIFE HOLDER SPRING	
19	146585001	1	シタメストリツケタ"イアンナイ	LOWER KNIFE HOLDER GUIDE	
20	062670612	2	ナヘ"コ357-40X6	SCREW 357X6	
21	146586000	1	メクラセン	OIL CAP	
24	146580001	1	ウフメスサト"ウウテ"	UPPER KNIFE DRIVING ARM	
25	148281101	1	ウフメスタ"キナツト	NUT	
26-1	144179001	1	ウフメスタ"キ	UPPER KNIFE HOLDER	
26-2	148345001	1	ウフメスタ"キ	UPPER KNIFE HOLDER	
27-1	107407003	1	シメネシ"4.37	SCREW 4.37	
27-2	102424004	1	シメネシ"4.37	SCREW 4.37	
28	148343101	1	ウフメスオサエ	UPPER KNIFE PRESSER	
29	148344001	1	ウフメスオサエイタ	UPPER KNIFE PRESSER PLATE	

H. ラフラー装置関係/Ruffling attachment/Kräuselvorrichtung/
 Accessoire pour fronces/Accessorio de fruncido

輸出用 /FOR EXPORT

- 067
- 069
- 071
- 073
- 074
- 075
- 076
- 077

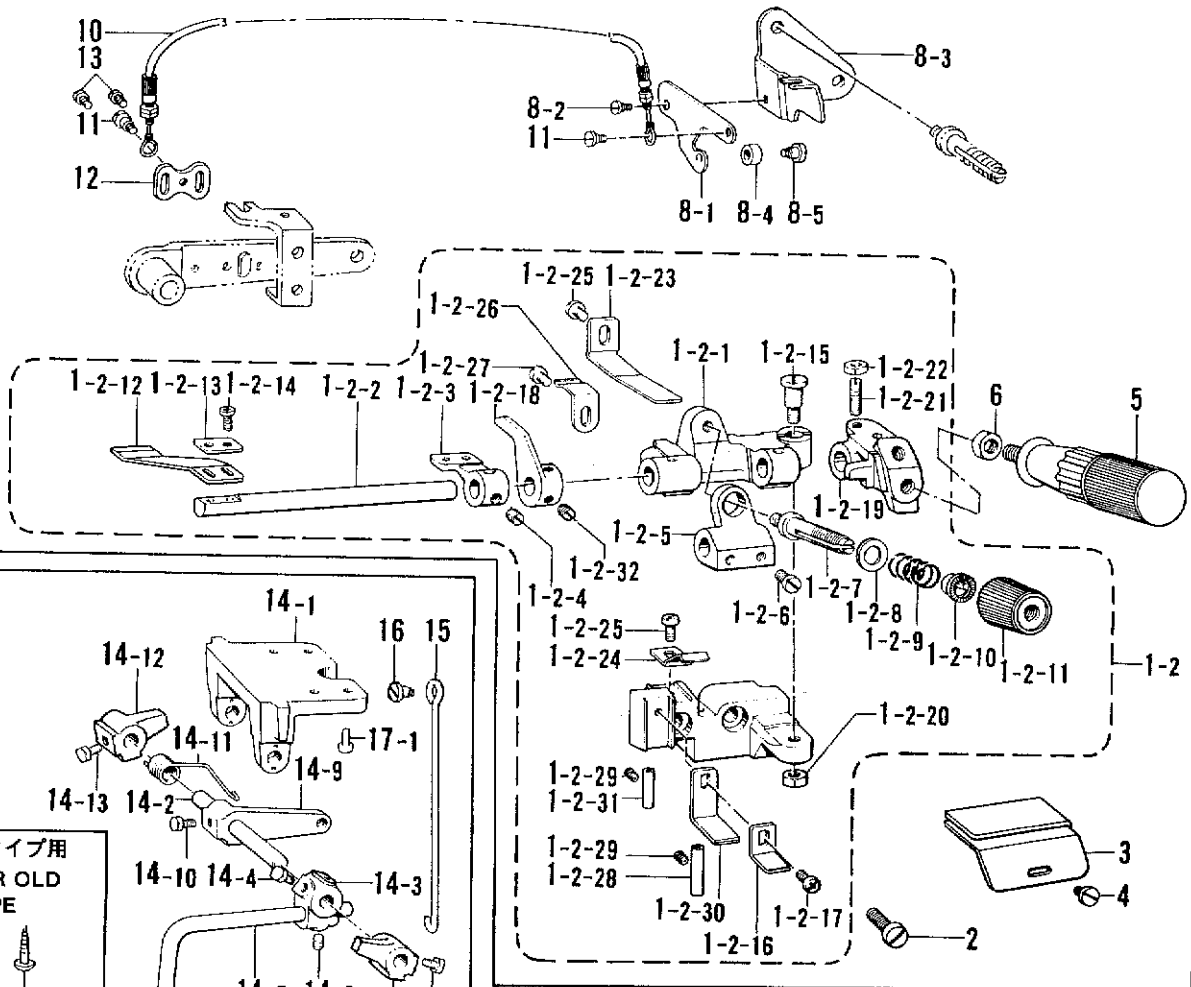

- 067
- 069
- 071
- 073
- 074
- 075
- 076
- 077

旧タイプ用
 FOR OLD
 TYPE

国内用 /FOR DOMESTIC

- 069
- 071
- 075
- 077

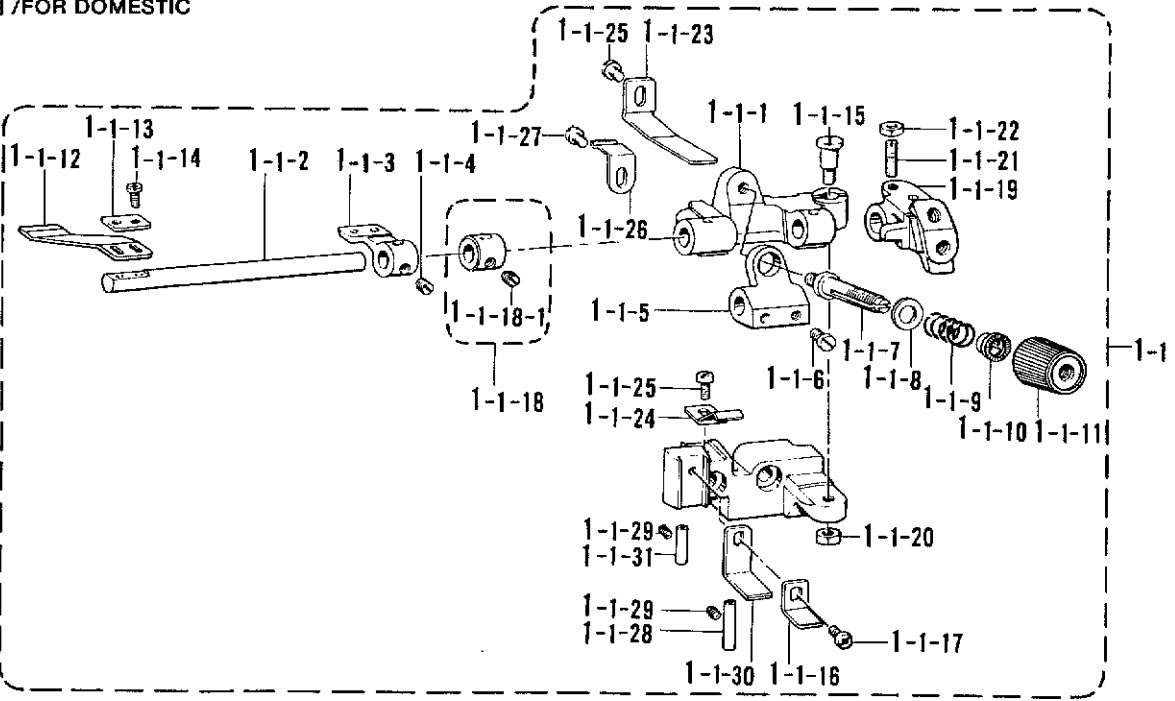

H. ラフラー装置関係/Ruffling attachment/Kräuselvorrichtung/
Accessoire pour fronces/Accessorio de fruncido

REF.NO.	CODE	Q'TY	ヒンメイ	NAME OF PARTS	RMKS
1-1	146587201	1	ラフラーソウチクミ	-----	
1-1-1	146588001	1	キシ"オサエタイ	-----	
1-1-2	145803001	1	キシ"オサエトリツクシク	-----	
1-1-3	146589001	1	ラツハト"タイ	-----	
1-1-4	101706001	2	トメネシ"6.35	-----	
1-1-5	146590001	1	ハ"ネウケ	-----	
1-1-6	105163001	2	アタマツキトメネシ"5.95	-----	
1-1-7	110820101	1	イトチヨウシホ"ウ	-----	
1-1-8	025770232	1	ヒラサ"カ"ネチユウ6.35	-----	
1-1-9	144788001	1	キシ"オサエハ"ネ	-----	
1-1-10	144105000	1	チヨウシハ"ネウエサ"カ"ネ	-----	
1-1-11	149566001	1	イトチヨウシナツト	-----	
1-1-12	144783001	1	キシ"オサエ	-----	
1-1-13	144784001	1	キシ"オサエサ"カ"ネ	-----	
1-1-14	062660712	2	ナヘ"コ318-40X7	-----	
1-1-15	147933001	1	タ"ンネシ"5.95	-----	
1-1-16	145807001	1	キシ"オサエタイアンナイ	-----	
1-1-17	062680812	1	ナヘ"コ437-40X8	-----	
1-1-18	181995002	1	セツトカラークミ	-----	
1-1-18-1	101706001	2	トメネシ"6.35	-----	
1-1-19	145810001	1	ハント"ルトリツクイタ	-----	
1-1-20	150553002	1	ナツト5.95	-----	
1-1-21	110230001	1	トメネシ"4.37	-----	
1-1-22	105234003	1	ナツト4.37	-----	
1-1-23	145811001	1	ハント"ルモト"シイタハ"ネ	-----	
1-1-24	145808001	1	キシ"オサエタイトメハ"ネ	-----	
1-1-25	062680612	2	ナヘ"コ437-40X6	-----	
1-1-26	144764001	1	マエフタメイタハ"ネ	-----	
1-1-27	060670512	1	ハ"イント"357-40X5	-----	
1-1-28	146592001	1	イトアンナイパイプ	-----	
1-1-29	013679412	2	トメネシ"3.57クホ"ミ	-----	
1-1-30	154795001	1	キシ"オサエタイアンナイD	-----	
1-1-31	S01614001	1	イトアンナイパイプ	-----	
1-2	S12677001	1	-----	RUFFLER ATTACHMENT ASSEMBLY	
1-2-1	146588001	1	-----	BRACKET FOR RUFFLING BLADE	
1-2-2	145803001	1	-----	RUFFLING BLADE BASE SHAFT	
1-2-3	146589001	1	-----	LAPPER BASE	
1-2-4	101706001	2	-----	SCREW 6.35	
1-2-5	146590001	1	-----	SPRING BASE	
1-2-6	105163001	2	-----	SCREW 5.95	
1-2-7	110820101	1	-----	TENSION CONTROL STUD	
1-2-8	025770232	1	-----	WASHER 6.35	
1-2-9	144788001	1	-----	SPRING	
1-2-10	144105000	1	-----	TENSION SPRING WASHER	
1-2-11	149566001	1	-----	THREAD TENSION ADJUSTING NUT	
1-2-12	144783001	1	-----	RUFFLING BLADE	
1-2-13	144784001	1	-----	WASHER	
1-2-14	062660712	2	-----	SCREW 318X7	
1-2-15	147933001	1	-----	STUD SCREW 5.95	
1-2-16	145807001	1	-----	RUFFLING BLADE GUIDE	
1-2-17	062680812	1	-----	SCREW 437X8	
1-2-18	148387001	1	-----	RUFFLING PLATE LIFTER	
1-2-19	145810001	1	-----	HANDLE FIXING PLATE	
1-2-20	150553002	1	-----	NUT 5.95	
1-2-21	110230001	1	-----	SCREW 4.37	
1-2-22	105234003	1	-----	NUT 4.37	
1-2-23	145811001	1	-----	SPRING PLATE	
1-2-24	145808001	1	-----	SPRING PLATE	
1-2-25	062680612	2	-----	SCREW 437X6	
1-2-26	144764001	1	-----	FRONT COVER STOPPER SPRING	
1-2-27	060670512	1	-----	SCREW 357X5	
1-2-28	146592001	1	-----	THREAD GUIDE PIPE	

H. ラフラー装置関係 / Ruffling attachment / Kräuselvorrichtung /
 Accessoire pour fronces / Accesorio de fruncido

輸出用 / FOR EXPORT

067
 069
 071
 073
 074
 075
 076
 077

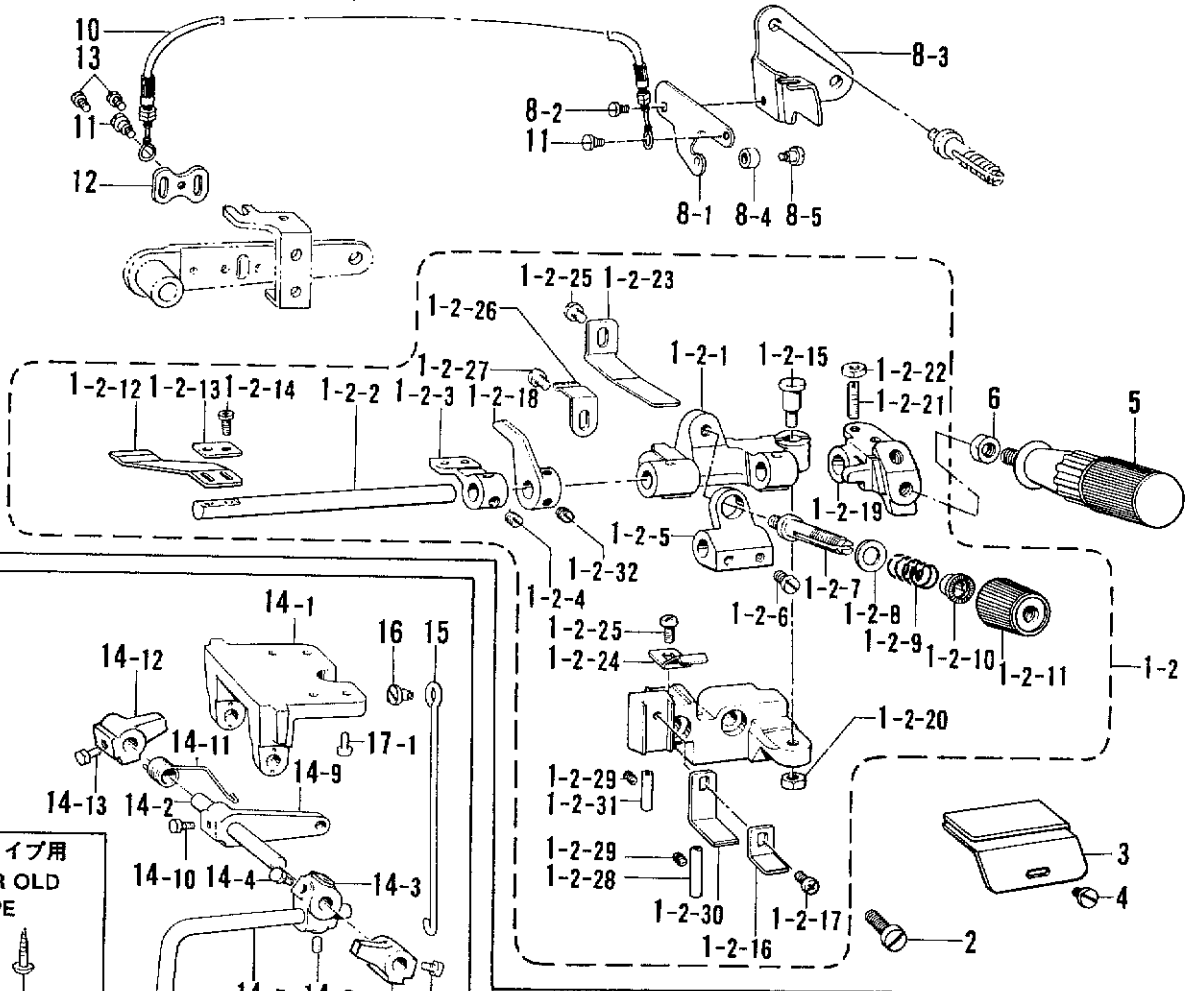

067
 069
 071
 073
 074
 075
 076
 077

旧タイプ用
 FOR OLD
 TYPE



17-2

国内用 / FOR DOMESTIC

069
 071
 075
 077

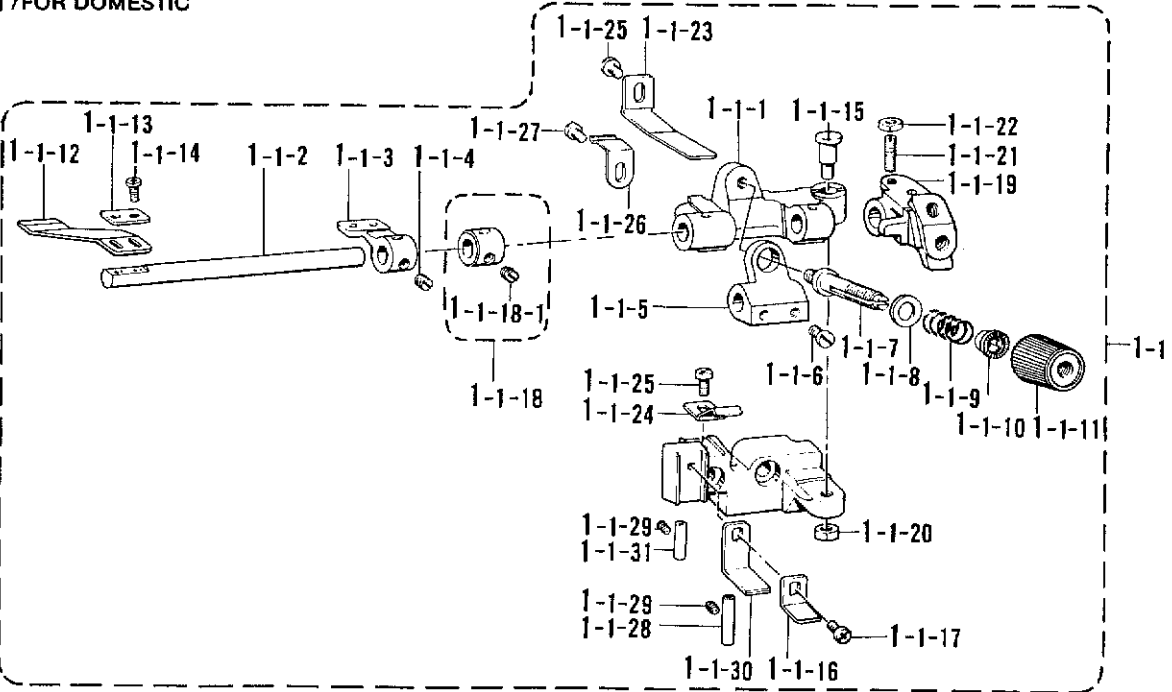

H. ラフラー装置関係 / Ruffling attachment / Kräuselvorrichtung /
 Accessoire pour fronces / Accesorio de fruncido

REF.NO.	CODE	Q'TY	ヒンメイ	NAME OF PARTS	RMKS
1-2-29	013679412	2	-----	SCREW 3.57	
1-2-30	154795001	1	-----	RUFFLING BLADE GUIDE PLATE (LOWER)	
1-2-31	S01614001	1	-----	THREAD GUIDE PIPE	
1-2-32	101706001	2	-----	SCREW 6.35	
2	S01304001	2	-----	SCREW 6.35X18	
3	144793000	1	-----	RUFFLER GUIDE	
4	112751002	1	-----	SCREW 3.57	
5	145809001	1	-----	HANDLE	
6	150556002	1	-----	NUT 6.35	
8	148395001	1	-----	RUFFLING PLATE LIFTER LEVER ASSEMBLY	
8-1	148388001	1	-----	RUFFLING PLATE LIFTER LEVER	
8-2	141514001	1	-----	SCREW	
8-3	148389001	1	-----	PRESSER FOOT LIFTER LEVER SUPPORTER	
8-4	148390001	1	-----	ROLLER	
8-5	112301001	1	-----	STUD SCREW 3.18	
10	148391001	1	-----	FLEXIBLE WIRE ASSEMBLY	
11	141514001	2	-----	SCREW	
12	147672001	1	-----	WIRE PLATE	
13	062670612	2	-----	SCREW 357X6	
14	155196201	1	サト"ウチヨウセツソウチクミ	DIFFERENTIAL ADJUSTMENT ASSEMBLY	
14-1	155197001	1	ヒザ"アテヨコシ"クウケ	KNEE LIFTER SHAFT BRACKET	
14-2	155198101	1	ヨコシ"ク	KNEE LIFTER SHAFT	
14-3	155199101	1	ヒザ"アテツキ"テ	KNEE LIFTER BRACKET	
14-4	017781012	2	ボ"ルト6.35X10	BOLT	
14-5	148797001	1	ヒザ"アゲ"タテシ"クS	KNEE LIFTER BAR (SMALL)	
14-6	014780622	1	アナトメネシ"6.35クボ"ミ	SCREW 6.35	
14-7	148798001	1	ヒザ"アテL	KNEE LIFTER PLATE (LARGE)	
14-8	100463001	1	4カクボ"ルト7.94	BOLT 7.94	
14-9	155201101	1	ヒザ"アテレバ"ー	KNEE LIFTER LEVER	
14-10	017781012	2	ボ"ルト6.35X10	BOLT 6.35X10	
14-11	155202001	1	ヒザ"アテレバ"ーハ"ネ	KNEE LIFTER LEVER SPRING	
14-12	155203201	2	ヨコシ"クトメク"	COLLAR	
14-13	017781012	4	ボ"ルト6.35X10	BOLT 6.35X10	
15	155205001	1	ヒザ"アテリンク	CONNECTING BAR	
16	146594001	1	タ"ンネシ"4.76	STUD SCREW 4.76	
17-1	062681012	4	ナヘ"コ437-40X10	SCREW 437X10	
17-2	032422505	4	+ マルモクネシ"4.1X25 (キユウタイプ トウフ"ウケヨウ)	SCREW 4.1X25 (FOR OLD TYPE HEAD BRACKET)	

J. ヒモ案内関係 / Gimp guide mechanism / Schnurführung /
 Mécanisme du guide-fil / Mecanismo guía del hilo

073
 074
 075
 076
 077

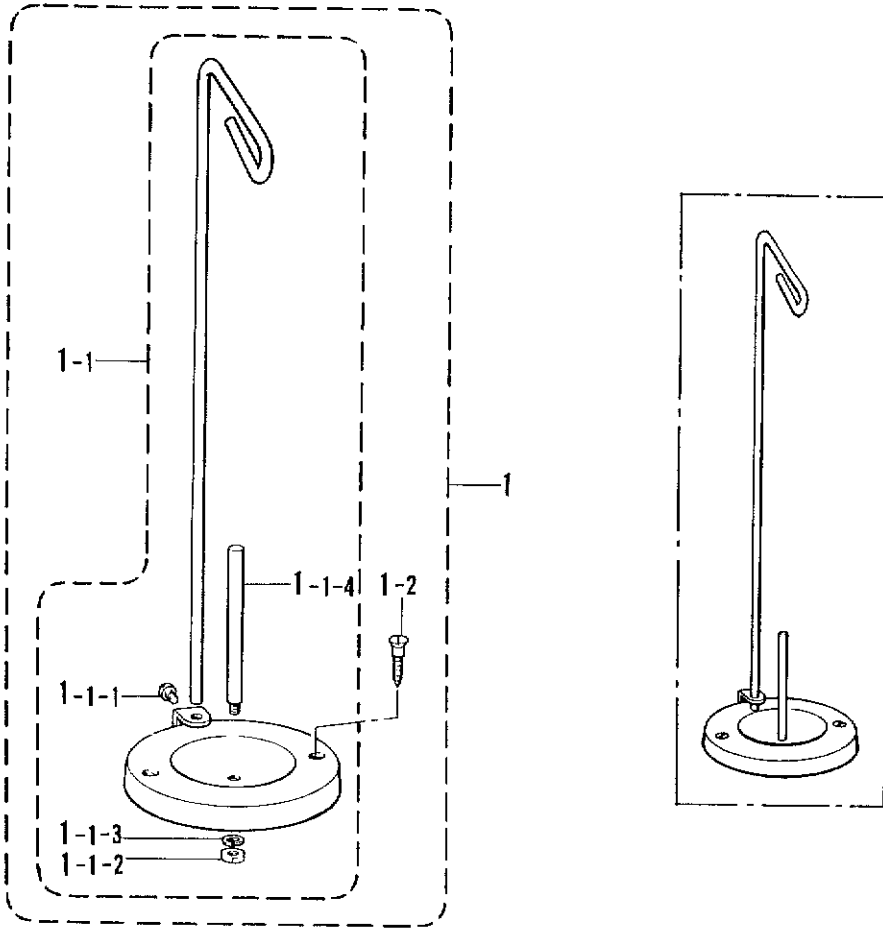

K. テープワインダー関係 / Tape winder mechanism / Bandaufwickelvorrichtung /
 Mécanisme de l'enrouleur de ruban / Mecanismo bobinador de cinta

073
 074
 075
 076
 077
 089
 090

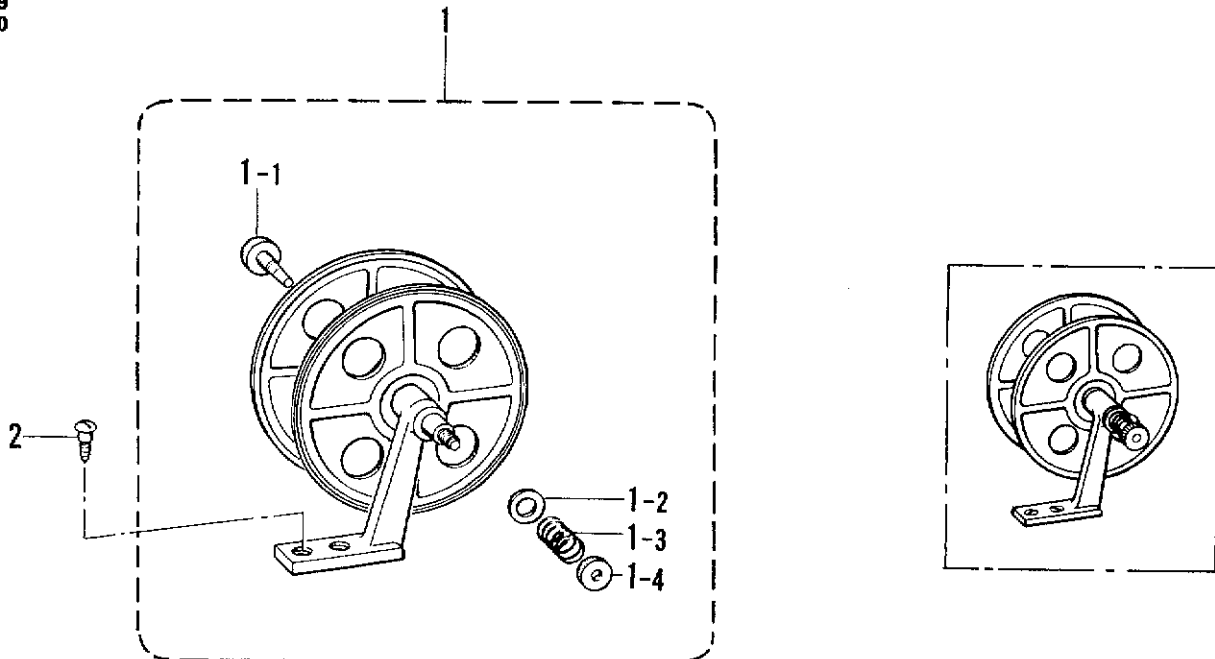

J. ヒモ案内関係 / Gimp guide mechanism / Schnurführung /
 Mécanisme du guide-fil / Mecanismo guía del hilo

REF.NO.	CODE	Q'TY	ヒンメイ	NAME OF PARTS	RMKS
1	181031001	1	イトタテダ"イクミネジ"ツキ	COTTON STAND ASSEMBLY WITH SCREW	
1-1	109854001	1	イトタテダ"イクミ	SPOOL STAND ASSEMBLY	
1-1-1	100080004	1	シメネジ"3.18	SCREW 3.18	
1-1-2	110161003	1	ナツト4.76	NUT 4.76	
1-1-3	028050242	1	ハ"ネサ"ガ"ネ2-5	SPRING WASHER 2-5	
1-1-4	100444002	1	イトタテホ"ウ	SPOOL STUD	
1-2	100447001	2	サラモクネジ"4.5X3.2	SCREW 4.5X3.2	

K. テープワインダー関係 / Tape winder mechanism / Bandaufwickelvorrichtung /
 Mécanisme de l'enrouleur de ruban / Mecanismo bobinador de cinta

REF.NO.	CODE	Q'TY	ヒンメイ	NAME OF PARTS	RMKS
1	143767002	1	テープワインダー"クミ	TAPE WINDER ASSEMBLY	
1-1	143980001	1	ツマミネジ"	THUMB SCREW	
1-2	108494001	1	サ"カ"ネ	WASHER	
1-3	108495001	1	テープワインダー"オシハ"ネ	SPRING	
1-4	100136001	1	イトチヨウシナツト	TENSION CONTROL NUT	
2	101118001	2	マルモクネジ"4.5X20	SCREW 4.5X20	

L. ラッパ関係/Lapper mechanism/Falz-Mechanismus/
 Mécanisme à rabat/Mecanismo de solapado

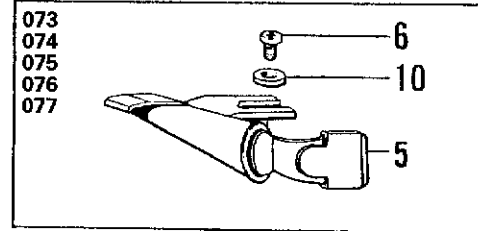
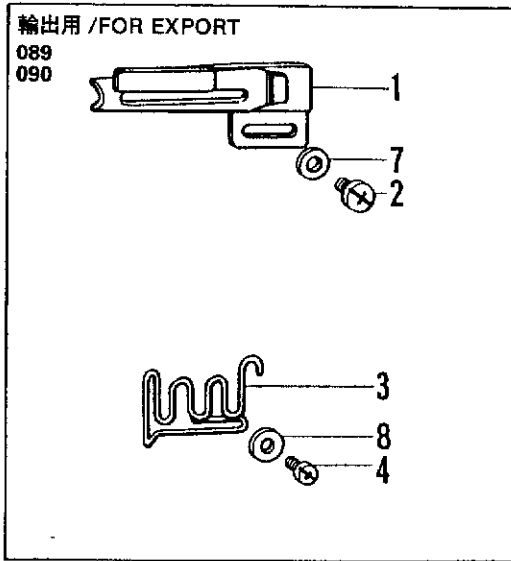

M. 下ルーバ関係/Under looper mechanism/Unterer Greifer/
 Mécanisme du boucleur inférieur/Mecanismo del presilladora inferior

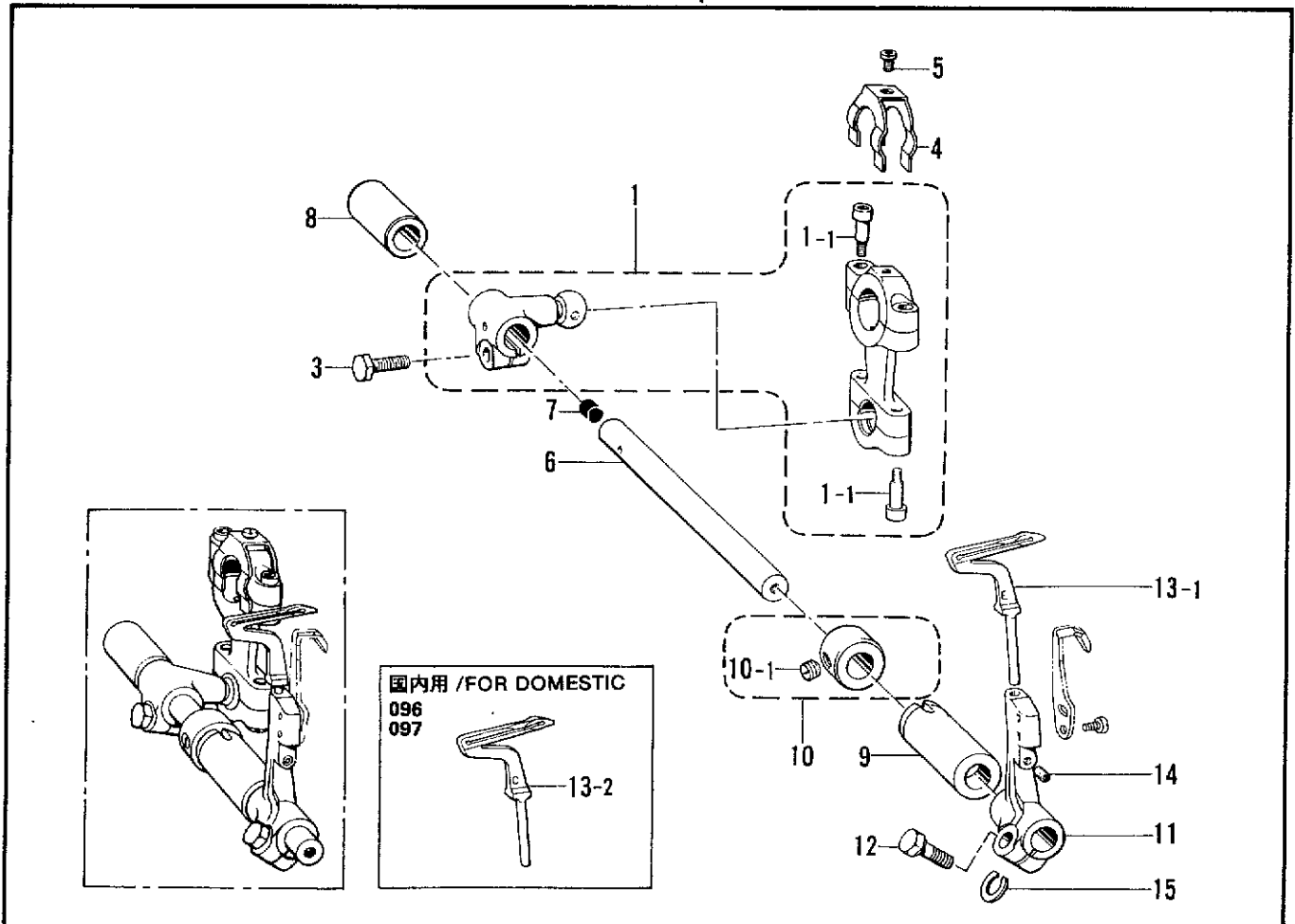

L. ラッパ-関係/Lapper mechanism/Falz-Mechanismus/
 Mécanisme à rabat/Mecanismo de solapado

REF.NO.	CODE	Q'TY	ヒンメイ	NAME OF PARTS	RMKS
1	147373000	1	-----	LAPPER ASSEMBLY	
2	062670512	2	-----	SCREW 357X5	
3	147377001	1	-----	TAPE GUIDE	
4	062670512	2	-----	SCREW 357X5	
5	147440000	1	ラッパ-クミ	LAPPER ASSEMBLY	
6	062680612	2	ナヘ"コ437-40X6	SCREW 437X6	
7	105161004	2	-----	WASHER	
8	025350332	2	-----	WASHER 3.5	
10	110735002	2	サ"カ"ネ	WASHER	

M. 下ルーバ-関係/Under looper mechanism/Unterer Greifer/
 Mécanisme du boucleur inférieur/Mecanismo del presilladora inferior

REF.NO.	CODE	Q'TY	ヒンメイ	NAME OF PARTS	RMKS
1	144044001	1	シタル-ハ°ロツト"クミ	UNDER LOOPER CONNECTING ROD ASSEMBLY	※
1-1	148425001	4	アナボ"ルト4.37X14	BOLT 4.37X14	
3	017771612	1	ボ"ルト6.35X16	BOLT 6.35X16	
4	110704001	1	ウフル-ハ°ロツト"フレ"メ	LOOPER CONNECTING ROD STOPPER	
5	062660412	1	ナヘ"コ318-40X4	SCREW 318X4	
6	146614001	1	シタル-ハ°シ"ク	UNDER LOOPER SHAFT	
7	140327001	1	ゴ"ムセ"ン	OIL CAP	
8	146615000	1	シタル-ハ°シ"クメタルB	UNDER LOOPER SHAFT BUSHING (REAR)	
9	146616000	1	シタル-ハ°シ"クメタルF	UNDER LOOPER SHAFT BUSHING (FRONT)	
10	180323001	1	シタシ"クセツトカラ"クミ	LOWER SHAFT SET COLLAR ASSEMBLY	
10-1	013760612	2	トメネシ"5.95クホ"ミ	SCREW 5.95	
11	146617001	1	シタル-ハ°トリツケ"ダイ	UNDER LOOPER HOLDER	
12	149171001	1	ボ"ルト5.56X14	BOLT 5.56X14	
13-1	S01248101	1	シタル-ハ°	UNDER LOOPER	
13-2	159884101	1	シタル-ハ°	-----	
14	014680422	1	アナトメネシ"4.37クホ"ミ	SCREW 4.37	
15	148782001	1	スヘ"ーサ	SPACER	

※クドウジクCクミ (B-1-1) 146917-001 ※ Crank Shaft (C) Assembly (B-1-1) 146917-001
 ※クドウジクHクミ (B-1-2, D-1, M-1, N-1) S01789-001 ※ Crank Shaft (H) Assembly (B-1-2, D-1, M-1, N-1) S01789-001
 ※クドウジクJクミ (B-1-3) S07847-001 ※ Crank Shaft (J) Assembly (B-1-3) S07847-001

N. 上ルーバ関係 / Over looper mechanism / Oberen Greifer /
 Mécanisme du boucleur supérieur / Mecanismo del presilladora superior

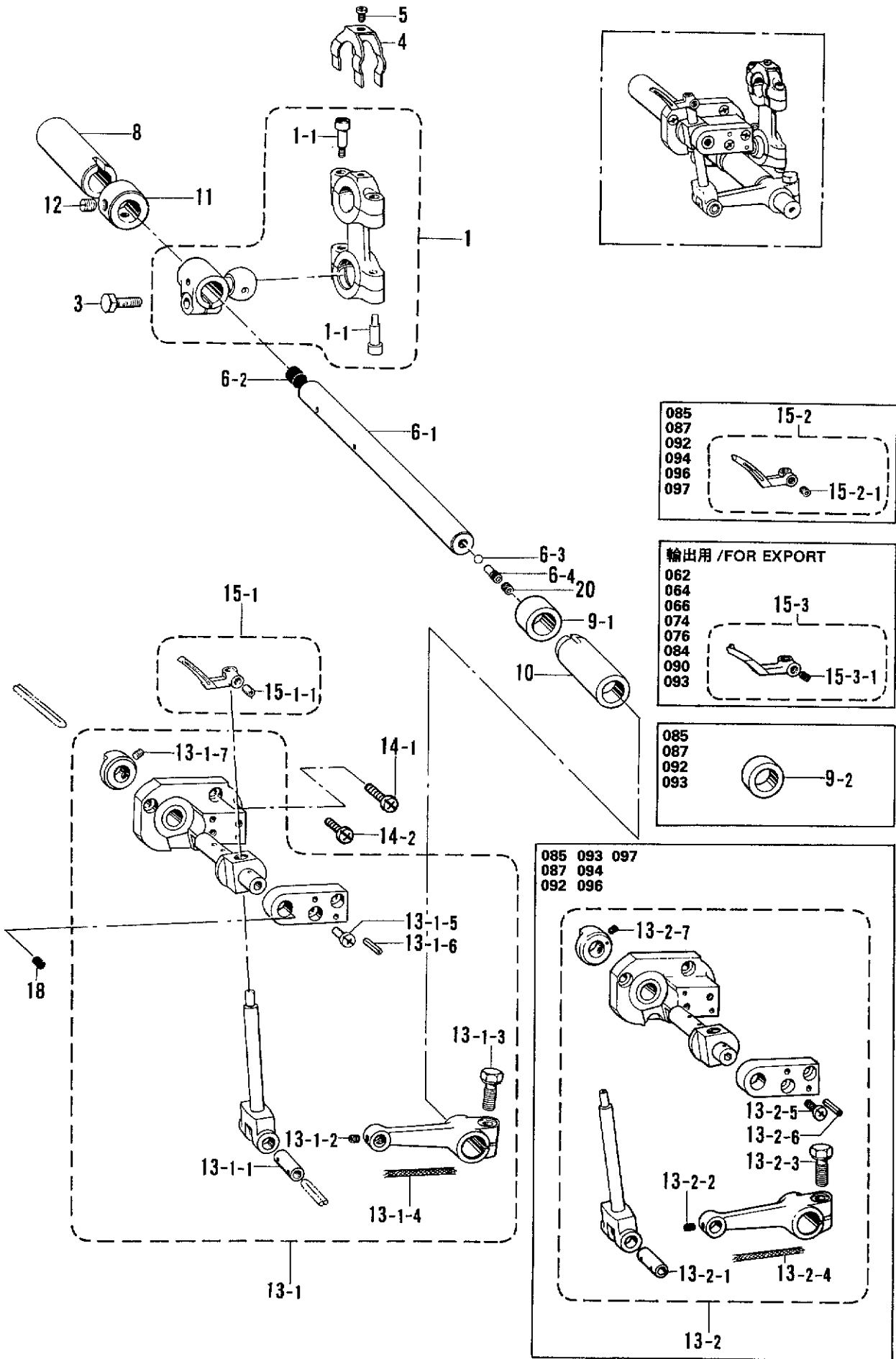

N. 上ルーバ関係/Over looper mechanism/Oberen Greifer/
 Mécanisme du boucleur supérieur/Mecanismo del presilladora superior

REF.NO.	CODE	Q'TY	ヒンメイ	NAME OF PARTS	RMKS
1	144025001	1	ウフルーパ°ロツト°クミ	UPPER LOOPER CONNECTING ROD ASSEMBLY	※
1-1	148425001	4	アナボ°ルト4.37X14	BOLT 4.37X14	
3	017771412	1	ボ°ルト6.35X14	BOLT 6.35X14	
4	110704001	1	ウフルーパ°ロツト°フレツト°メ	LOOPER CONNECTING ROD STOPPER	
5	062660412	1	ナヘ°コ318-40X4	SCREW 318X4	
6	S06294001	1	ウフルーパ°シ°ククミ	OVER LOOPER SHAFT ASSEMBLY	
6-1	148033001	1	ウフルーパ°シ°ク	OVER LOOPER SHAFT	
6-2	140327001	1	コ°ムセン	OIL CAP	
6-3	071023850	1	コウキユウ3/32	STEEL BALL 3/32"	
6-4	148034001	1	オイルチヨウセツネシ°	OIL ADJUSTING SCREW	
8	144029000	1	ウフルーパ°シ°クメタルB	OVER LOOPER SHAFT BUSHING (REAR)	
9-1	146602001	1	ウフルーパ°シ°クカラ-	OVER LOOPER SHAFT COLLAR	
9-2	S01597001	1	ウフルーパ°シ°クカラ-	OVER LOOPER SHAFT COLLAR	
10	144031000	1	ウフルーパ°シ°クメタルF	OVER LOOPER SHAFT BUSHING (FRONT)	
11	146581001	1	セツトカラ-	SET COLLAR	
12	100260001	2	トメネシ°5.95	SCREW 5.95	
13-1	146603301	1	ウフルーパ°キ°コウクミ	OVER LOOPER ASSEMBLY	
13-1-1	148379001	1	ウフルーパ°ウデ°シ°ク	OVER LOOPER HOLDING SHAFT	
13-1-2	148294001	1	アナトメネシ°3.57クホ°ミ	SCREW 3.57	
13-1-3	149170001	1	ボ°ルト6.35X16	BOLT 6.35X16	
13-1-4	140416000	1	クミヒモ	WICK	
13-1-5	062681012	2	ナヘ°コ437-40X10	SCREW 437X10	
13-1-6	047301440	2	スプリング°ピン°AW3	SPRING PIN AW3	
13-1-7	014680422	2	アナトメネシ°4.37クホ°ミ	SCREW 4.37	
13-2	146611301	1	ウフルーパ°キ°コウクミ	OVER LOOPER ASSEMBLY	
13-2-1	148379001	1	ウフルーパ°ウデ°シ°ク	OVER LOOPER HOLDING SHAFT	
13-2-2	148294001	1	アナトメネシ°3.57クホ°ミ	SCREW 3.57	
13-2-3	149170001	1	ボ°ルト6.35X16	BOLT 6.35X16	
13-2-4	140416000	1	クミヒモ	WICK	
13-2-5	062681012	2	ナヘ°コ437-40X10	SCREW 437X10	
13-2-6	047301440	2	スプリング°ピン°AW3	SPRING PIN AW3	
13-2-7	014680422	2	アナトメネシ°4.37クホ°ミ	SCREW 4.37	
14-1	062680712	1	ナヘ°コ437-40X7	SCREW 437X7	
14-2	S10774001	2	ナヘ°コ437-40X7	SCREW 437X7	
15-1	147934001	1	ウフルーパ°ネシ°ツキ	OVER LOOPER WITH SCREW	
15-1-1	014680422	1	アナトメネシ°4.37クホ°ミ	SCREW 4.37	
15-2	159686001	1	ウフルーパ°ネシ°ツキ	OVER LOOPER WITH SCREW	
15-2-1	014680422	1	アナトメネシ°4.37クホ°ミ	SCREW 4.37	
15-3	147935001	1	-----	OVER SPREADER WITH SCREW	
15-3-1	014680422	1	-----	SCREW 4.37	
18	159101000	1	メクラセン	OIL CAP	
20	148294001	1	アナトメネシ°3.57クホ°ミ	SCREW 3.57	

※クドウジクCクミ (B-1-1) 146917-001 ※ Crank Shaft (C) Assembly (B-1-1) 146917-001
 ※クドウジクHクミ (B-1-2, D-1, M-1, N-1) S01789-001 ※ Crank Shaft (H) Assembly (B-1-2, D-1, M-1, N-1) S01789-001
 ※クドウジクJクミ (B-1-3) S07847-001 ※ Crank Shaft (J) Assembly (B-1-3) S07847-001

P. 二重環ルーバ関係/Double chain stitch looper mechanism/Doppelkettenstichgreifer/
 Mécanisme du boucleur pour point de chaînette double/Mecanismo del presilladora de doble cadeneta

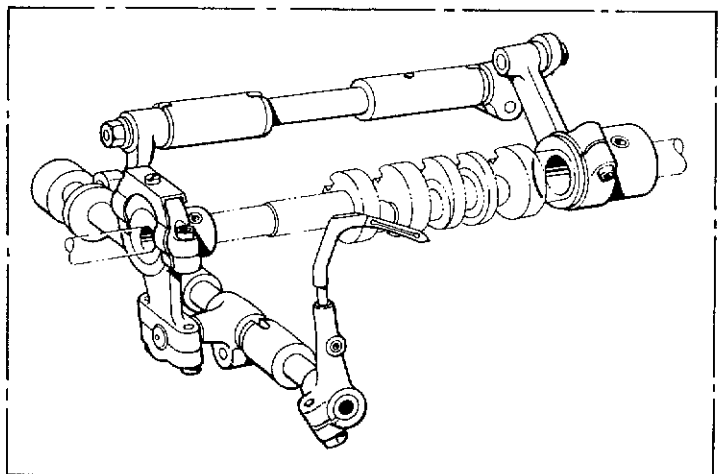
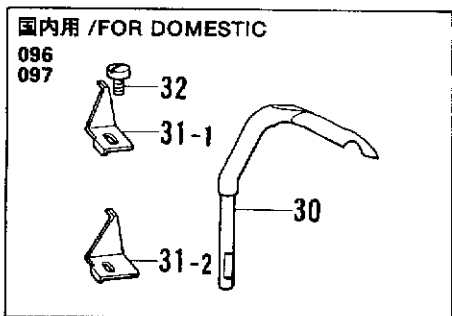
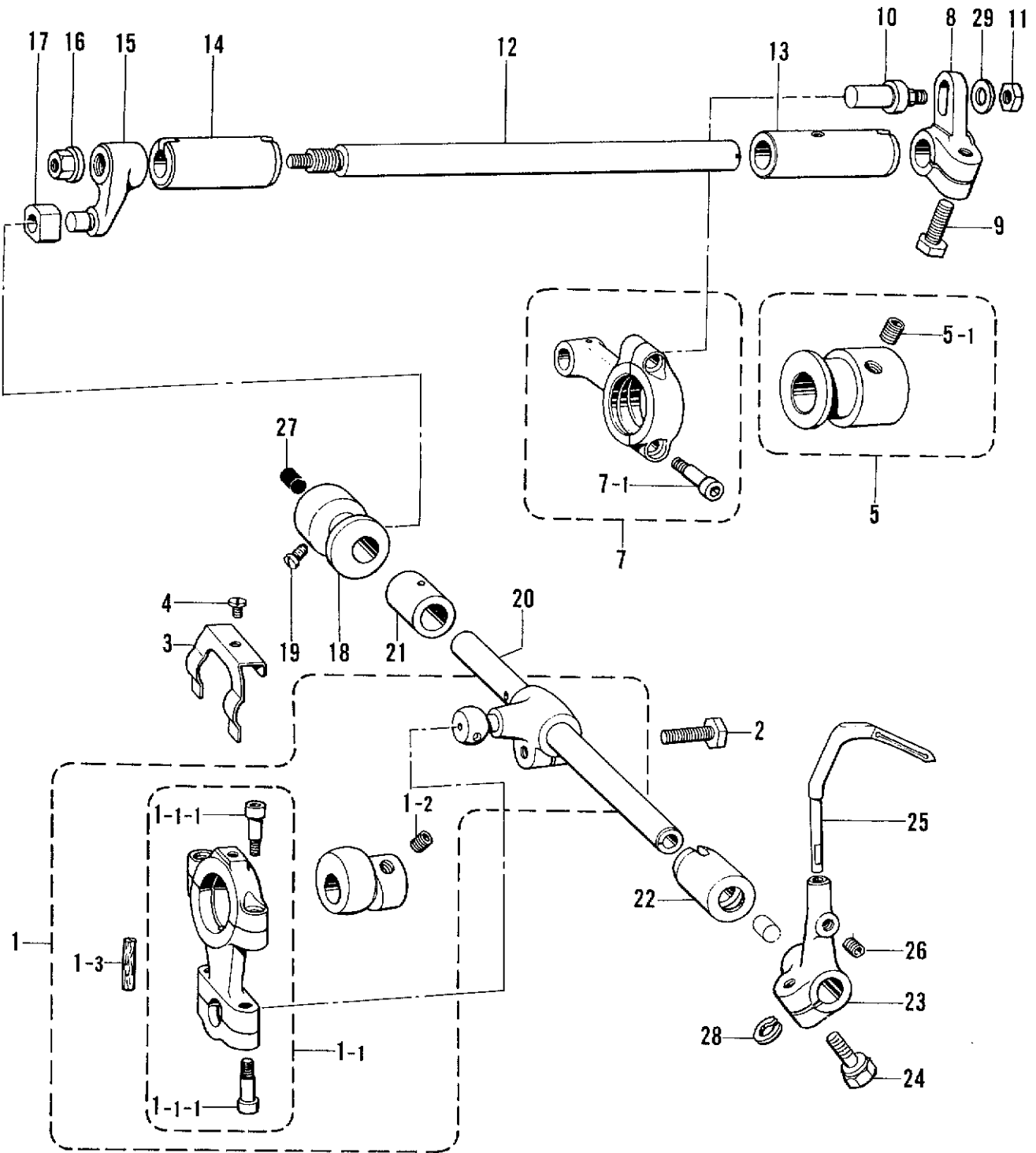

P. 二重環ルーパ関係/Double chain stitch looper mechanism/Doppelkettenstichgreifer/
 Mécanisme du boucleur pour point de chaînette double/Mecanismo del presilladora de doble cadeneta

REF.NO.	CODE	Q'TY	ヒンメイ	NAME OF PARTS	RMKS
1	146618001	1	ヨウト"ウロツト"クミ	LONGITUDINAL FEED ROD ASSEMBLY	
1-1	S01225001	1	ヨウト"ウロツト"ネジ"ツキ	LONGITUDINAL FEED ROD WITH SCREW	
1-1-1	148425001	4	アナホ"ルト4.37X14	BOLT 4.37X14	
1-2	014770622	2	アナトメネジ"6.35クホ"ミ	SCREW 6.35	
1-3	147691000	1	フエルト	FELT	
2	017771612	1	ホ"ルト6.35X16	BOLT 6.35X16	
3	146622001	1	ヨウト"ウロツト"フレト"メ	LOOPER CONNECTING ROD STOPPER	
4	062660412	1	ナヘ"ゴ318-40X4	SCREW 318X4	
5	147988001	1	DLヘンジンリンクミ	ECCENTRIC CAM (RIGHT)	
5-1	014770622	2	アナトメネジ"6.35クホ"ミ	SCREW 6.35	
7	146624101	1	セ"ンゴ"ロツト"クミ	LONGITUDINAL FEED ROD ASSEMBLY	
7-1	148425001	2	アナホ"ルト4.37X14	BOLT 4.37X14	
8	146626001	1	セ"ンゴ"レハ"-R	FEED LEVER (RIGHT)	
9	017771612	1	ホ"ルト6.35X16	BOLT 6.35X16	
10	146627001	1	セ"ンゴ"ロツト"ヒ"ン	PIN	
11	110161006	1	ナツト4.76	NUT 4.76	
12	146628001	1	セ"ンゴ"レハ"-シ"ク	LONGITUDINAL FEED LEVER SHAFT	
13	140150000	1	レハ"-シ"クメタルR	DRIVING LEVER SHAFT BUSHING (R)	
14	146629000	1	レハ"-シ"クメタルL	LONGITUDINAL FEED LEVER SHAFT BUSHING(L)	
15	146630001	1	セ"ンゴ"レハ"-L	FEED LEVER (LEFT)	
16	110778002	1	ザ"ツキナツト5.56	NUT 5.56	
17	140313001	1	セ"ンゴ"レハ"-カクゴ"マ	LONGITUDINAL FEED LEVER SLIDE BLOCK	
18	146631001	1	セ"ンゴ"コマ	LONGITUDINAL FEED CAM	
19	120990001	2	アタマツキトメネジ"4.37	SCREW 4.37	
20	146632001	1	セ"ンゴ"シ"ク	LONGITUDINAL FEED SHAFT	
21	146633000	1	セ"ンゴ"シ"クメタルB	LONGITUDINAL SHAFT BUSHING (REAR)	
22	140159000	1	セ"ンゴ"シ"クメタルF	LONGITUDINAL FEED SHAFT BUSHING (FRONT)	
23	155262001	1	ニジ"ユウカンルーパ"ホルダ"	CHAIN STITCH LOOPER HOLDER	
24	149171001	1	ホ"ルト5.56X14	BOLT 5.56X14	
25	146635001	1	ニジ"ユウカンルーパ"	CHAIN STITCH LOOPER	
26	014680422	1	アナトメネジ"4.37クホ"ミ	SCREW 4.37	
27	140327001	2	ゴ"ムセン	OIL CAP	
28	148782001	1	スヘ"ーサ	SPACER	
29	153484001	1	サ"カ"ネ4.76	WASHER 4.76	
30	S01756001	1	タンガンルーパ"	-----	
31-1	S01757001	1	イトサハ"キ(5MM,097)	-----	
31-2	S01761001	1	イトサハ"キ(3MM,096)	-----	
32	S01295001	1	シメネジ"2.38X3.5	-----	

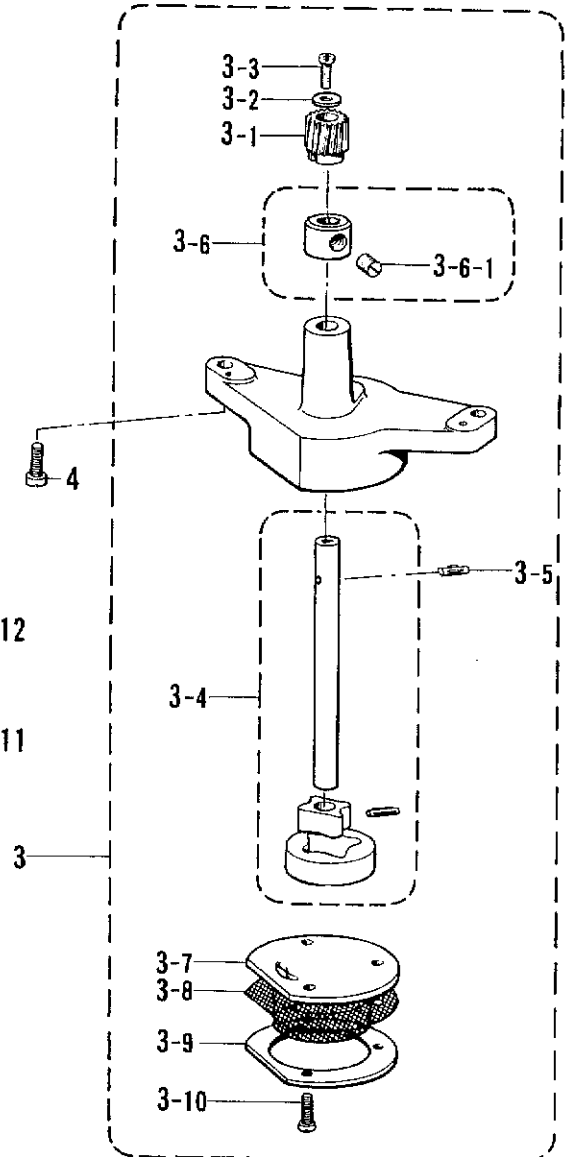
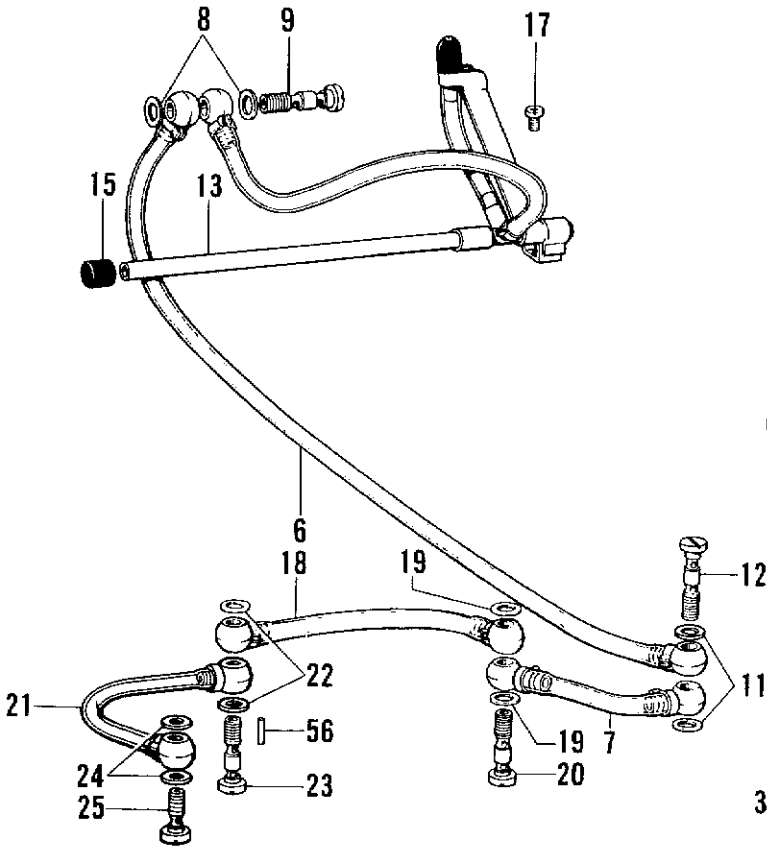
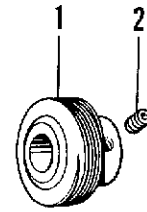
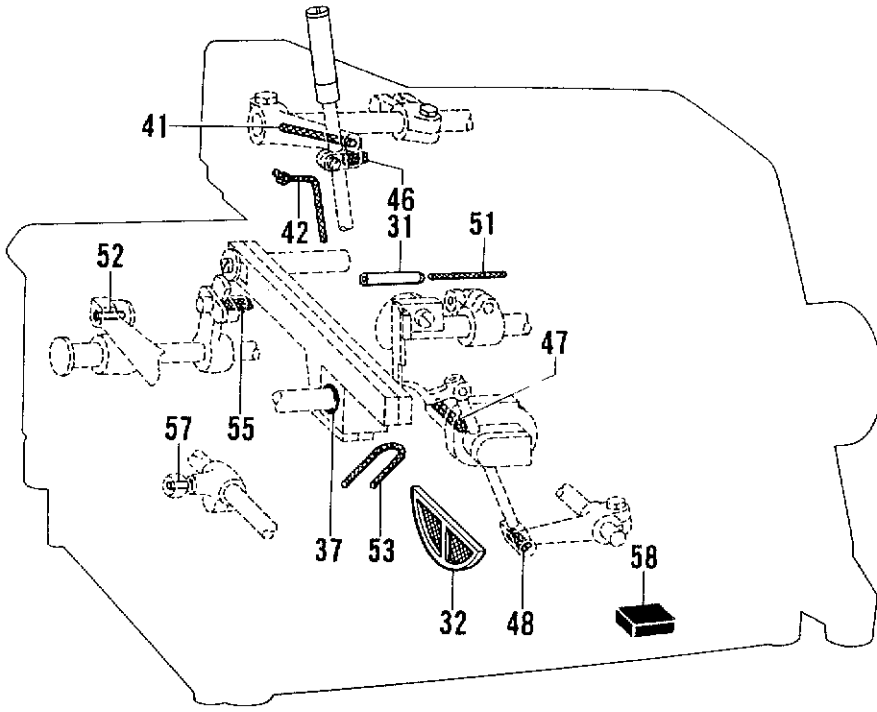

Q. 給油・潤滑関係 / Lubrication / Schmierung / Lubrification / Lubricación

REF.NO.	CODE	Q'TY	ヒンメイ	NAME OF PARTS	RMKS
1	146647001	1	ウオーム	WORM	
2	014770622	2	アナトメネジ"6.35クホ"ミ	SCREW 6.35	
3	147521001	1	トロコイト"ポンプ"クミ	PUMP ASSEMBLY	
3-1	144619000	1	ウオームホイール	WORM WHEEL	
3-2	025350332	1	ヒラサ"カ"ネタ"イ3.5	WASHER 3.5	
3-3	062670812	1	ナヘ"コ357-40X8	SCREW 357X8	
3-4	147523001	1	ポンプ"ローター"クミ	PUMP INNER ROTER ASSEMBLY	
3-5	144622001	1	ミゾ"ツキヒン"カ"タ	CASTLE PIN	
3-6	181995001	1	セツカ"カラ"クミ	SET COLLAR ASSEMBLY	
3-6-1	101706001	2	トメネジ"6.35	SCREW 6.35	
3-7	147527001	1	ポンプ"フタ	PUMP COVER	
3-8	147528100	1	ロカモク	OIL FILTER	
3-9	147529001	1	ロカモク"ウサエ	OIL FLANGE FILTER	
3-10	062671012	3	ナヘ"コ357-40X10	SCREW 357X10	
4	062711212	2	ナヘ"コ476-32X12	SCREW 476X12	
6	140780101	1	ビ"ニルチューブ"クミ	VINYL TUBE ASSEMBLY	
7	140779101	1	ビ"ニルチューブ"クミ	VINYL TUBE ASSEMBLY	
8	112348001	2	パ"ツキン	PACKING	
9	112364001	1	ハイユ"パ"イフ"ツキ"テネジ"	SCREW	
11	112348001	2	パ"ツキン	PACKING	
12	112364001	1	ハイユ"パ"イフ"ツキ"テネジ"	SCREW	
13	146636201	1	ロツト"オイル"パイプ"クミ	MAIN OIL PIPE ASSEMBLY	
15	140325001	1	ゴ"ム"セン	OIL CAP	
17	062670612	1	ナヘ"コ357-40X6	SCREW 357X6	
18	140778101	1	ビ"ニルチューブ"クミ	VINYL TUBE ASSEMBLY	
19	112348001	2	パ"ツキン	PACKING	
20	112364001	1	ハイユ"パ"イフ"ツキ"テネジ"	SCREW	
21	140778101	1	ビ"ニルチューブ"クミ	VINYL TUBE ASSEMBLY	
22	112348001	2	パ"ツキン	PACKING	
23	112364001	1	ハイユ"パ"イフ"ツキ"テネジ"	SCREW	
24	112348001	2	パ"ツキン	PACKING	
25	112359001	1	ハイユ"パ"イフ"ツキ"テネジ"	SCREW	
31	147217000	1	オイル"パイプ"	OIL PIPE	
32	145664000	1	オイル"フィルター"	OIL FILTER	
37	114294001	1	O"リング"	O RING	
41	140418000	1	クミ"ヒモ	WICK	
42	150307000	1	クミ"ヒモ	WICK	
46	140415000	2	クミ"ヒモ	WICK	
47	140317000	1	クミ"ヒモ	WICK	
48	140417000	1	クミ"ヒモ	WICK	
51	112735000	1	クミ"ヒモ	WICK	
52	147318000	1	ピン	PIN	
53	147361000	1	クミ"ヒモ	WICK	
55	147363000	1	フェルト	FELT	
56	147318000	1	ピン	PIN	
57	147318000	1	ピン	PIN	
58	112525000	1	シユウジ"ン"マグ"ネット	MAGNET	

R. 糸調子関係 / Thread tension / Fadenspannung / Tension du fil / Tension del hilo

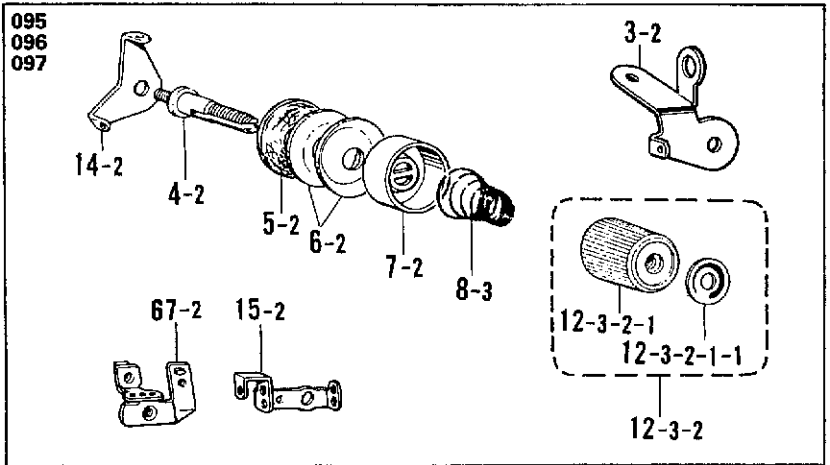
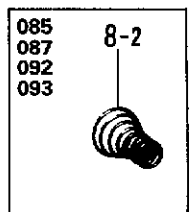
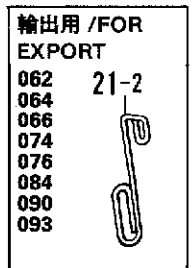
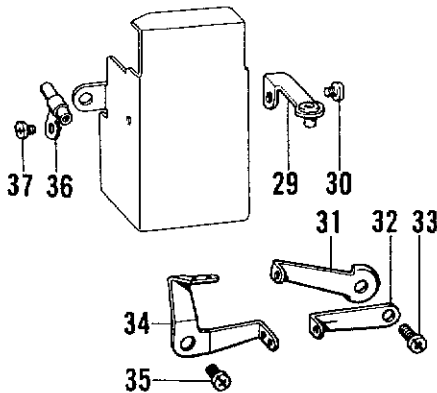
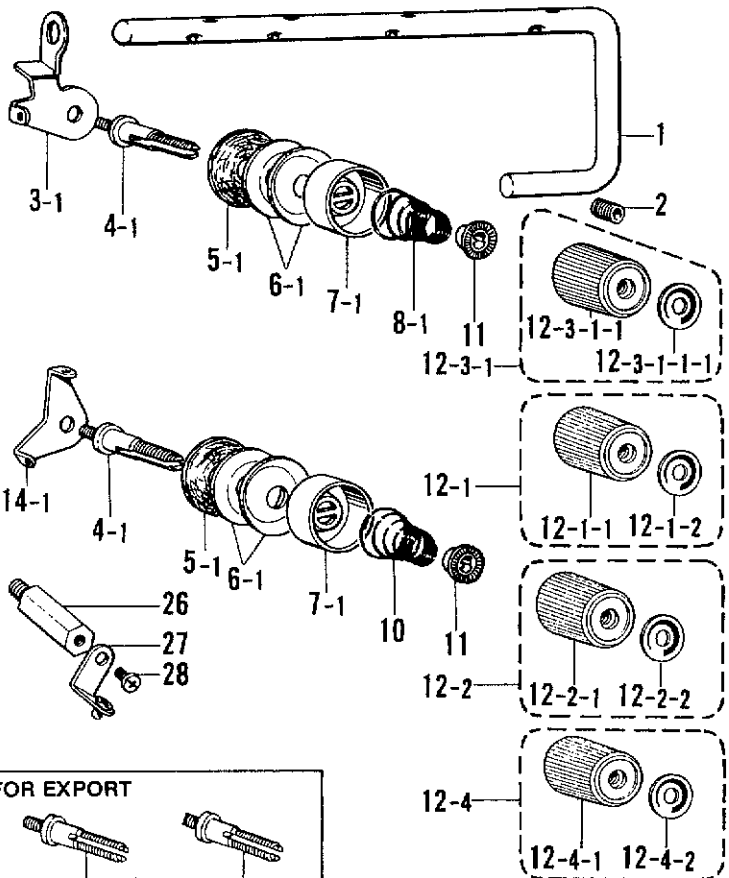
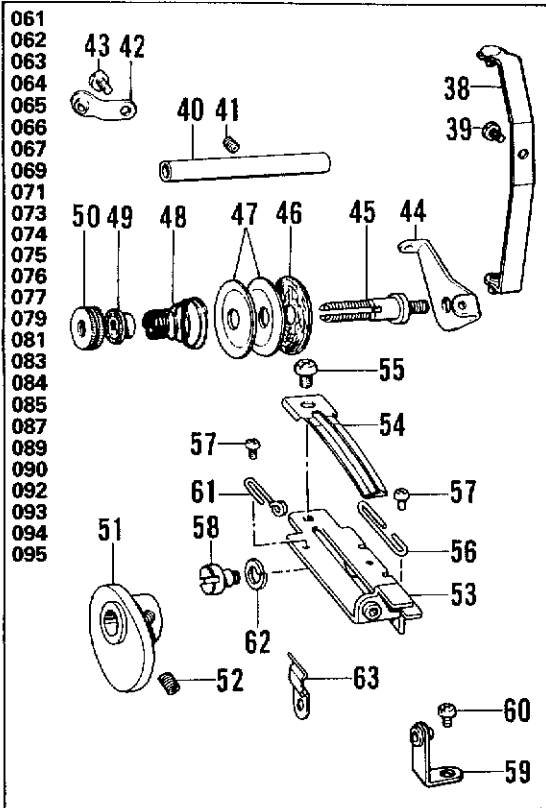
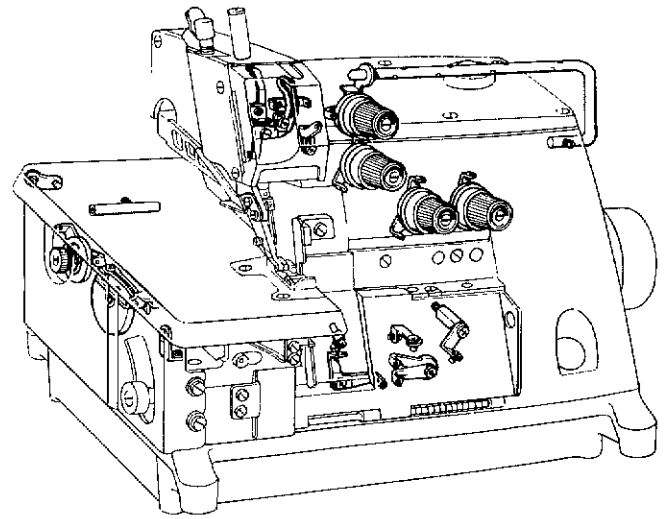
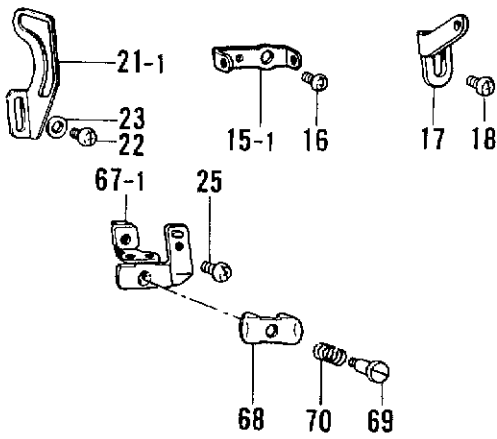

R. 糸調子関係/Thread tension/Faderspannung/Tension du fil/Tension del hilo

REF.NO.	CODE	Q'TY	ヒンメイ	NAME OF PARTS	RMKS
1	146648001	1	シュイトアンナイ	MAIN THREAD GUIDE	
2	014770622	1	アナトメネシ"6.35クホ"ミ	SCREW 6.35	
3-1	146649001	1	イトアンナイササエ	THREAD GUIDE SUPPORTER	
3-2	156509001	1	イトアンナイササエ	THREAD GUIDE SUPPORTER	
4-1	110820101	4	イトチヨウシホ"ウ	TENSION CONTROL STUD	
4-2	110820101	5	イトチヨウシホ"ウ	TENSION CONTROL STUD	
4-3	159574101	2	-----	TENSION CONTROL STUD	
4-4	110820101	2	-----	TENSION CONTROL STUD	
5-1	110832001	4	イトチヨウシサラフエルト	TENSION DISC FELT	
5-2	110832001	5	イトチヨウシサラフエルト	TENSION DISC FELT	
6-1	145446001	8	イトチヨウシサラ	TENSION DISC	
6-2	145446001	10	イトチヨウシサラ	TENSION DISC	
7-1	144103002	4	イトチヨウシサラオサエ	TENSION DISC WASHER	
7-2	144103002	5	イトチヨウシサラオサエ	TENSION DISC WASHER	
8-1	144104001	2	ハリイトチヨウシハ"ネ	NEEDLE TENSION SPRING	
8-2	148851001	2	ハリイトチヨウシハ"ネ	NEEDLE TENSION SPRING	
8-3	144104001	3	ハリイトチヨウシハ"ネ	NEEDLE TENSION SPRING	
10	144110001	2	シタルーパ°イトチヨウシハ"ネ	LOWER LOOPER TENSION SPRING	
11	144105000	4	チヨウシハ"ネウエサ"カ"ネ	TENSION SPRING WASHER	
12-1	149568001	1	イトチヨウシナツクミ	THREAD TENSION CONTROL NUT	
12-1-1	149566001	1	イトチヨウシナツ	THREAD TENSION NUT	
12-1-2	147049001	1	キヨウシ"ヤクハ"ン	TENSION INDICATING PLATE	
12-2	149568002	1	イトチヨウシナツクミ	THREAD TENSION CONTROL NUT	
12-2-1	149566001	1	イトチヨウシナツ	THREAD TENSION NUT	
12-2-2	147049002	1	キヨウシ"ヤクハ"ン	TENSION INDICATING PLATE	
12-3-1	149568003	1	イトチヨウシナツクミ	THREAD TENSION CONTROL NUT	
12-3-1-1	149566001	1	イトチヨウシナツ	THREAD TENSION NUT	
12-3-1-1-1	147049003	1	キヨウシ"ヤクハ"ン	TENSION INDICATING PLATE	
12-3-2	149568003	2	イトチヨウシナツクミ	THREAD TENSION CONTROL NUT	
12-3-2-1	149566001	2	イトチヨウシナツ	THREAD TENSION NUT	
12-3-2-1-1	147049003	2	キヨウシ"ヤクハ"ン	TENSION INDICATING PLATE	
12-4	149568004	1	イトチヨウシナツクミ	THREAD TENSION CONTROL NUT	
12-4-1	149566001	1	イトチヨウシナツ	THREAD TENSION NUT	
12-4-2	147049004	1	キヨウシ"ヤクハ"ン	TENSION INDICATING PLATE	
14-1	110813001	3	ハリイトアンナイ	NEEDLE THREAD GUIDE	
14-2	110813001	4	ハリイトアンナイ	NEEDLE THREAD GUIDE	
15-1	143757001	1	ハリイトアンナイA	NEEDLE THREAD GUIDE (A)	
15-2	146793001	1	ニホンハ"リハリイトアンナイ	TWIN NEEDLE NEEDLE THREAD GUIDE	
16	062660412	1	ナヘ"コ318-40X4	SCREW 318X4	
17	146650001	1	ニジ"ユウカンハリイトアンナイ	CHAIN STITCH NEEDLE THREAD GUIDE	
18	060670812	1	ハ"イント"357-40X8	SCREW 3.57X8	
21-1	144108001	1	ハリイトテンヒ"ン	NEEDLE THREAD TAKE-UP	
21-2	142201001	1	-----	NEEDLE THREAD TAKE-UP	
22	062660412	1	ナヘ"コ318-40X4	SCREW 318X4	
23	105248003	1	サ"ガ"ネ	WASHER	
25	062670612	1	ナヘ"コ357-40X6	SCREW 357X6	
26	144111001	1	シタルーパ°イトアンナイササエ	LOOPER THREAD GUIDE HOLDER	
27	146926002	1	イトアンナイクミ	UNDER LOOPER THREAD GUIDE ASSEMBLY	
28	062670612	1	ナヘ"コ357-40X6	SCREW 357X6	
29	146929001	1	ウワルーパ°イトアンナイクミ	LOOPER THREAD GUIDE ASSEMBLY	
30	062670612	1	ナヘ"コ357-40X6	SCREW 357X6	
31	146652001	1	ウワルーパ°テンヒ"ンR	OVER LOOPER THREAD TAKE-UP (RIGHT)	
32	146653001	1	シタルーパ°テンヒ"ンR	UNDER LOOPER THREAD TAKE-UP (RIGHT)	
33	062670812	1	ナヘ"コ357-40X8	SCREW 357X8	
34	146654001	1	ルーパ°テンヒ"ンL	LOOPER THREAD TAKE-UP (LEFT)	
35	062670612	1	ナヘ"コ357-40X6	SCREW 357X6	
36	142669002	1	イトアンナイハ°イフ°クミ	OVER LOOPER THREAD GUIDE PIPE ASSEMBLY	
37	060630312	1	ハ"イント"238-56X3	SCREW 2.38X3	
38	146925001	1	イトアンナイクミ	THREAD GUIDE ASSMBLY	
39	062670612	1	ナヘ"コ357-40X6	SCREW 357X6	
40	146656001	1	イトアンナイハ°イフ°	THREAD GUIDE PIPE	
41	148294001	1	アナトメネシ"3.57クホ"ミ	SCREW 3.57	

R. 糸調子関係 / Thread tension / Faderspannung / Tension du fil / Tension del hilo

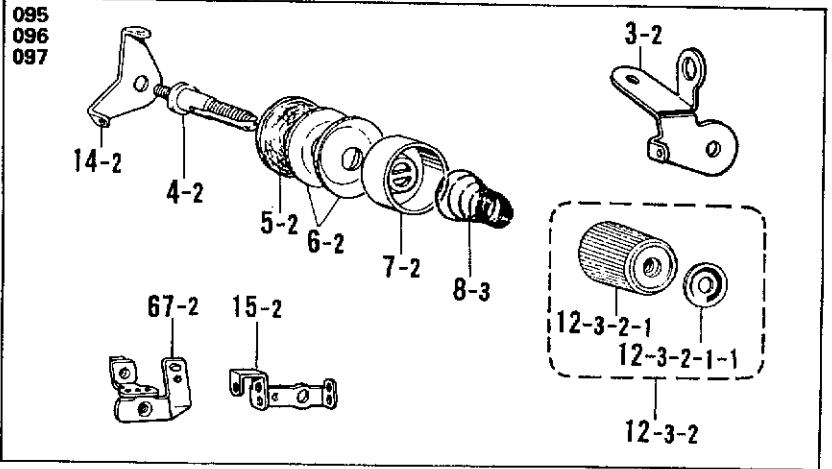
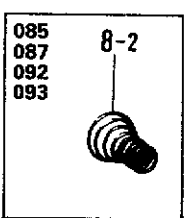
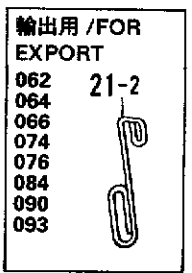
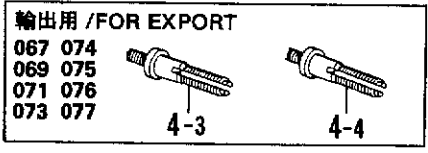
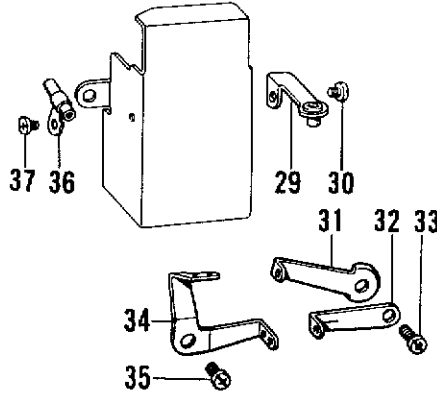
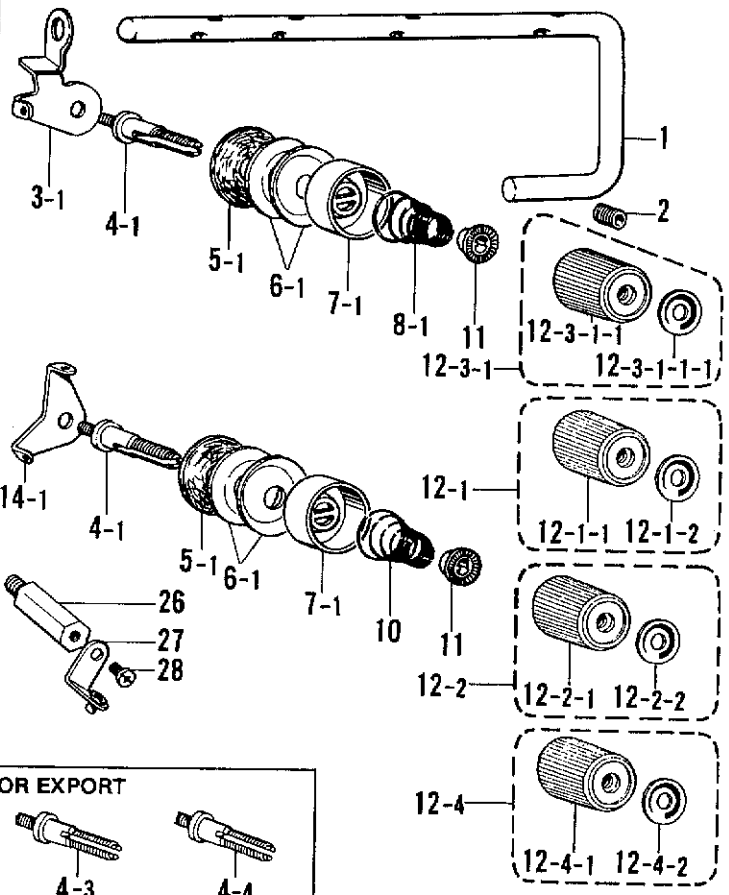
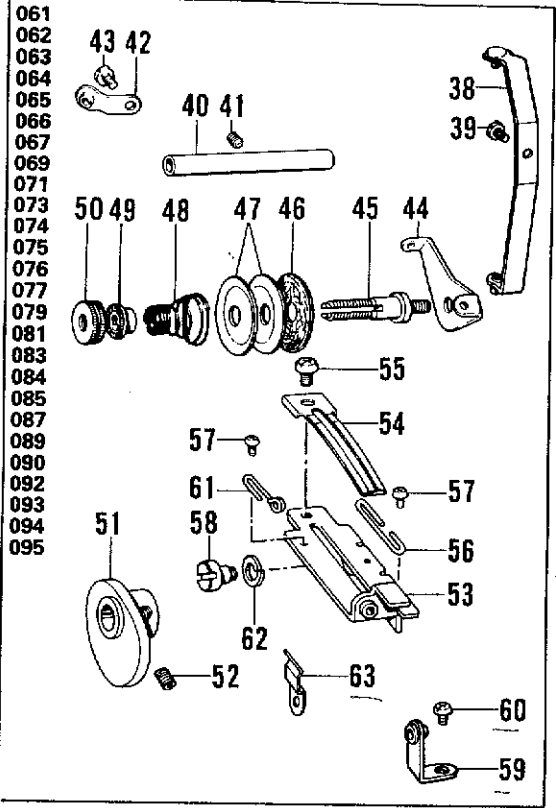
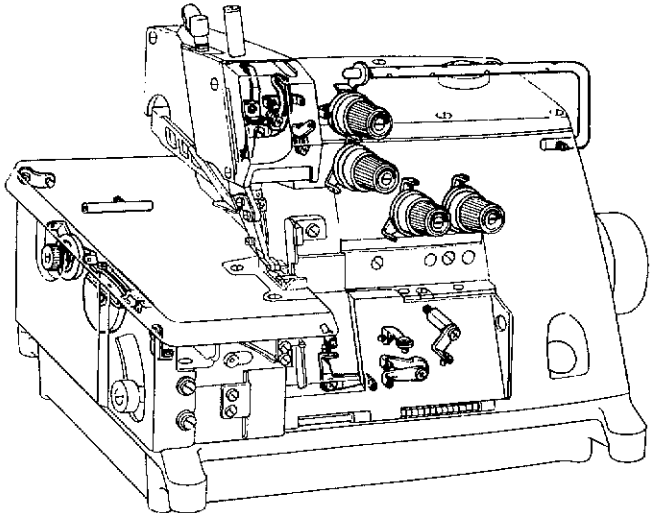
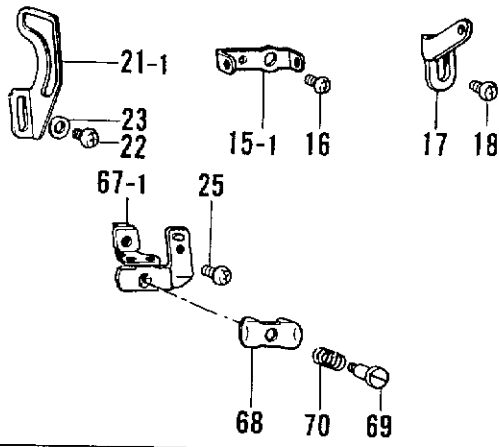

R. 糸調子関係/Thread tension/Faderspannung/Tension du fil/Tension del hilo

REF.NO.	CODE	Q'TY	品名	NAME OF PARTS	RMKS
42	151617001	1	ニジユウカンイトアンナイクミ	CHAIN STITCH LOOPER THREAD GUIDE ASS.	
43	062670612	1	ナヘ"コ357-40X6	SCREW 357X6	
44	110813001	1	ハリイトアンナイ	NEEDLE THREAD GUIDE	
45	147148001	1	イトチヨウシホ"ウ	THREAD TENSION CONTROL STUD	
46	110832001	1	イトチヨウシサラフェルト	TENSION DISC FELT	
47	145446001	2	イトチヨウシサラ	TENSION DISC	
48	147149001	1	イトチヨウシハ"ネ	THREAD TENSION SPRING	
49	144105000	1	チヨウシハ"ネウエサ"カ"ネ	TENSION SPRING WASHER	
50	151012001	1	ナツト	UPPER THREAD TENSION NUT	
51	150807101	1	ニジユウカンテンビ"ンクミ	CHAIN STITCH LOOPER TAKE-UP	
52	014680422	2	アナトメネジ"4.37クホ"ミ	SCREW 4.37	
53	150808001	1	イトサハ"キト"タ"イクミ	CHAIN STITCH BASE PLATE ASSEMBLY	
54	150810001	1	テンビ"ンイトサハ"キ	THREAD HANDLER	
55	062670412	1	ナヘ"コ357-40X4	SCREW 357X4	
56	146663001	1	テンビ"ンイトアンナイR	THREAD GUIDE (RIGHT)	
57	060630412	2	ハ"イント"238-56X4	SCREW 2.38X4	
58	150812001	1	タ"ンネジ"4.37	STUD SCREW 4.37	
59	146930001	1	イトアンナイクミ	THREAD GUIDE	
60	062670612	1	ナヘ"コ357-40X6	SCREW 357X6	
61	S07293001	1	テンビ"ンイトアンナイL	THREAD GUIDE (L)	
62	028050242	1	ハ"ネサ"カ"ネ2-5	SPRING WASHER 2-5	
63	150813001	1	ト"タ"イオサエハ"ネ	SPRING	
67-1	147344001	1	コチヨウシキトリツケタ"イクミ	NEEDLE THREAD TAKE-UP SUPPORTER ASSEMBLY	
67-2	156511001	1	コチヨウシキトリツケタ"イクミ	NEEDLE THREAD TAKE-UP SUPPORTER ASSEMBLY	
68	112300001	1	ハリイトオサエ	NEEDLE THREAD PRESSER	
69	112301001	1	タ"ンネジ"3.18	STUD SCREW 3.18	
70	112299001	1	ハリイトアンナイオシハ"ネ	SPRING	

Z. 付属品関係 / Accessories / Zubehör / Accessoires / Accesorios

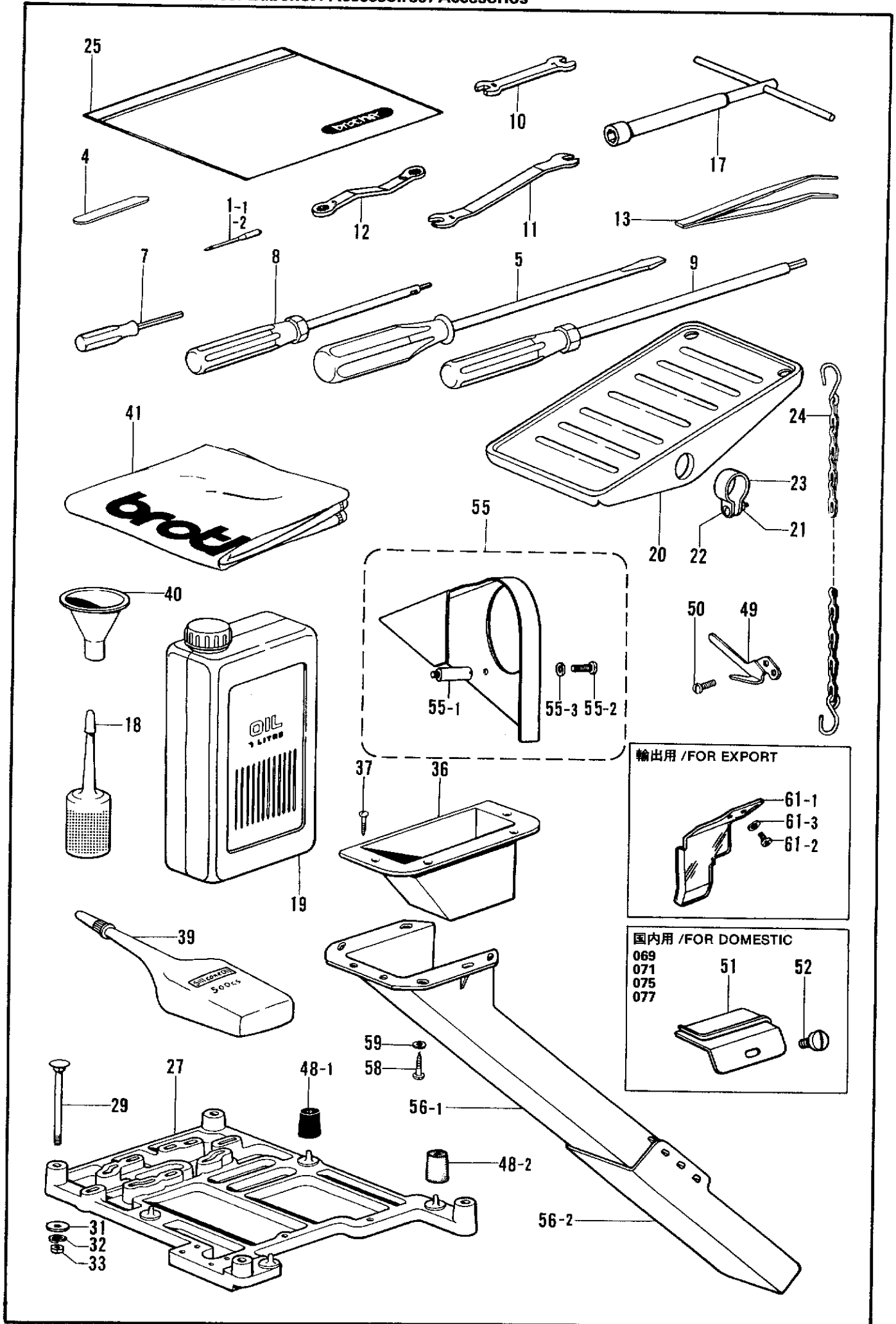

Z. 付属品関係 / Accessories / Zubehör / Accessoires / Accesorios

REF.NO.	CODE	Q'TY	ヒンメイ	NAME OF PARTS	RMKS
1-1	*	4	ミシンハリDCX1	NEEDLE DCX1	
1-2	*	4	ミシンハリDMX13	NEEDLE DMX13	
4	112436001	1	シタメス	LOWER KNIFE	
5	101572101	1	ネジ"マワシ5.5X190	SCREW DRIVER 5.5X190	
7	S01943001	1	6カクホ"ウネジ"マワシ1.6	SCREW DRIVER 1.6	
8	146700001	1	6カクホ"ウネジ"マワシ2	SCREW DRIVER 2	
9	149173001	1	6カクホ"ウネジ"マワシ3	SCREW DRIVER 3	
10	107779001	1	スパナ6X7	SPANNER 6X7	
11	143566001	1	スパナ8	SPANNER 8	
12	105343001	1	メガネレンチ8X9	WRENCH 8X9	
13	117466000	1	ピンセット	TWEEZERS	
17	140342001	1	ソケットレンチクミ	SOCKET WRENCH ASSEMBLY	
18	S06701000	1	ホリオイルラークミ	OILER ASSEMBLY	
19	145277105	1	オイルタンク	OIL TANK	
20	147893003	1	オサエアケ"フミイタ	TREADLE PEDAL	
21	021400106	2	1シユナツト4	NUT 4	
22	062401406	2	ナヘ"コ4X14	SCREW 4X14	
23	116016001	2	ヘタルトメ	PEDAL STOPPER	
24	142262001	1	クサリフクミ	CHAIN ASSEMBLY	
25	122991001	1	フソク"クヒン"ホリフクロ	ACCESSORY BAG	
27	S03888000	1	トウフ"ウケ	HEAD PLATE	
29	210973001	4	カクネホ"ルト8X85	BOLT 8X85	
31	025080236	4	ヒラサ"カ"ネチユウ8	WASHER 8	
32	028080242	4	ハ"ネサ"カ"ネ2-8	SPRING WASHER 2-8	
33	021080106	4	ナツト1シユ8	NUT 8	
36	148430101	1	ダ"スタート"ロツフ	DUSTER DROP	
37	031311302	4	マルモクネジ"3.1X13	SCREW 3.1X13	
39	S06704001	1	シリコンオイル	SILICONE OIL	
40	140759000	1	シ"ヨー"ゴ	FUNNEL	
41	144225002	1	トウフ"カハ"ー	HEAD COVER	
48-1	147919001	1	ホ"ウシンゴ"ム	CUSHION	
48-2	147919002	3	ホ"ウシンゴ"ム	CUSHION	
49	140888001	1	カラヌイメス	TRIMMING KNIFE	
50	062660412	2	ナヘ"コ318-40X4	SCREW 318X4	
51	144793000	1	キシ"アンナイ	-----	
52	112751002	1	シメネジ"3.57	-----	
55	148348001	1	ヘ"ルトカハ"ー"クミ	-----	
55-1	148042001	2	ヘ"ルトカハ"ー"スタツト"	-----	
55-2	062681012	2	ナヘ"コ437-40X10	-----	
55-3	100645003	2	サ"カ"ネ	-----	
56	183161201	1	ダ"スター"シユートクミ	DUSTER SHOOT ASSEMBLY	
56-1	148431201	1	ダ"スター"シユートL	DUSTER SHOOT (LARGE)	
56-2	148432001	1	ダ"スター"シユートS	DUSTER SHOOT (SMALL)	
58	101118001	4	マルモクネジ"4.5X20	SCREW 4.5X20	
59	025050236	4	ヒラサ"カ"ネチユウ5	WASHER 5	
61	151017001	1	-----	EYE GUARD ASSEMBLY	
61-1	150550000	1	-----	EYE GUARD FOR OVERLOCK	
61-2	062660512	2	-----	SCREW 318X5	
61-3	025030232	2	-----	WASHER 3	

※ 付属品の明細は変更することがあります。

※ The details of included accessories are subject to change.

※ Änderungen in der Aufstellung der Mitgelieferten Zubehöre sind vorbehalten.

※ Les détails des accessoires inclus sont sujets à des changements.

※ Los detalles de los accesorios incluidos pueden variar.

095

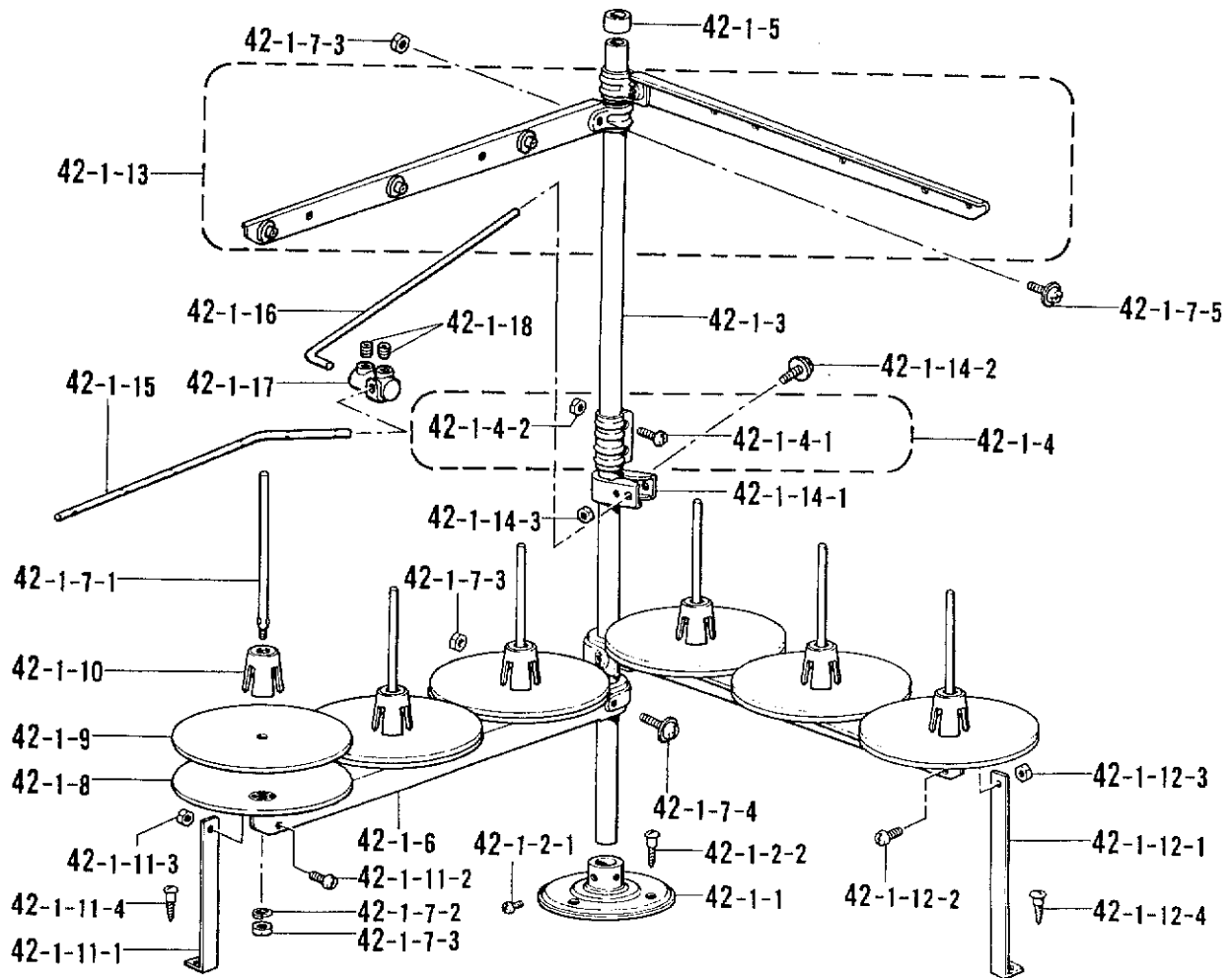

Z. 付属品関係 / Accessories / Zubehör / Accessoires / Accesorios

REF.NO.	CODE	Q'TY	ヒンメイ	NAME OF PARTS	RMKS
42-1	S02772101	1	イトテテタ"イク≡6THF <095>	COTTON STAND ASSEMBLY 6THF <095>	
42-1-1	150189002	1	ブ"ラケット	BRACKET	
42-1-2	S02773001	1	ブ"ラケットネシ"セット	COTTON STAND BASE SCREW SET	
42-1-2-1	062060806	2	ナヘ"コ6X8	SCREW 6X8	
42-1-2-2	031452206	3	マルモク45X22	SCREW 45X22	
42-1-3	150172002	2	コラムパイプ	COLUMN PIPE	
42-1-4	150106002	1	コラムシ"ョイントクミ	COLUMN JOINT ASSEMBLY	
42-1-4-1	062501406	2	ナヘ"コ5X14	SCREW 5X14	
42-1-4-2	021500106	2	1シュナット5	NUT 5	
42-1-5	150174000	1	コラムキャップ	COLUMN CAP	
42-1-6	S02779001	2	スプ"ールホルダ"ー3	SPOOL HOLDER 3	
42-1-7	S02782001	2	スプ"ールネシ"セット3	SPOOL SCREW SET 3	
42-1-7-1	150179002	6	スプ"ールシ"クB	SPOOL SHAFT (B)	
42-1-7-2	028050246	6	ハ"ネサ"カ"ネ2-5	SPRING WASHER 2-5	
42-1-7-3	021500106	10	1シュナット5	NUT 5	
42-1-7-4	050503006	2	ナヘ"コヒラサ"5X30	SCREW 5X30	
42-1-7-5	050501406	2	ナヘ"コヒラサ"5X14	SCREW 5X14	
42-1-8	150180000	6	ウケサ"ラ	SPOOL STAND BASE	
42-1-9	150182000	6	スプ"ールマット	SPOOL MAT	
42-1-10	126863001	6	スプ"ールクッション	SPOOL CUSHION	
42-1-11	S02784001	1	ホルダ"ーササエAセット	SPOOL HOLDER SUPPORTER (A) SET	
42-1-11-1	150188002	1	スプ"ールホルダ"ーササエA	SPOOL HOLDER SUPPORTER (A)	
42-1-11-2	062501006	1	ナヘ"コ5X10	SCREW 5X10	
42-1-11-3	021500106	1	1シュナット5	NUT 5	
42-1-11-4	031452206	1	マルモク45X22	SCREW 45X22	
42-1-12	S02785001	1	ホルダ"ーササエBセット	SPOOL HOLDER SUPPORTER (B) SET	
42-1-12-1	150194002	1	スプ"ールホルダ"ーササエB	SPOOL HOLDER SUPPORTER (B)	
42-1-12-2	062501006	1	ナヘ"コ5X10	SCREW 5X10	
42-1-12-3	021500106	1	1シュナット5	NUT 5	
42-1-12-4	031452206	1	マルモク45X22	SCREW 45X22	
42-1-13	S02788001	2	スレット"ハンガ"ーク≡3	THREAD HANGER ASSEMBLY 3	
42-1-14	150145002	1	イトアンナイホルダ"ーク≡3	THREAD GUIDE HOLDER ASSEMBLY	
42-1-14-1	150185002	1	イトアンナイホルダ"ー	THREAD GUIDE HOLDER	
42-1-14-2	050503006	1	ナヘ"コヒラサ"5X30	SCREW 5X30	
42-1-14-3	021500106	1	1シュナット5	NUT 5	
42-1-15	S02783001	1	イトアンナイ6	THREAD GUIDE 6	
42-1-16	S04109001	1	イトアンナイササエホ"ウ	THREAD GUIDE SUPPORTER BAR	
42-1-17	138843001	1	ササエホ"ウツキ"テ	JOINT	
42-1-18	014060632	2	アナトメ6X6クホ"≡	SCREW 6X6	

※ 付属品の明細は変更することがあります。

※ The details of included accessories are subject to change.

※ Änderungen in der Aufstellung der Mitgelieferten Zubehöre sind vorbehalten.

※ Les détails des accessoires inclus sont sujets à des changements.

※ Los detalles de los accesorios incluidos pueden variar.

Z. 付属品関係 / Accessories / Zubehör / Accessoires / Accesorios

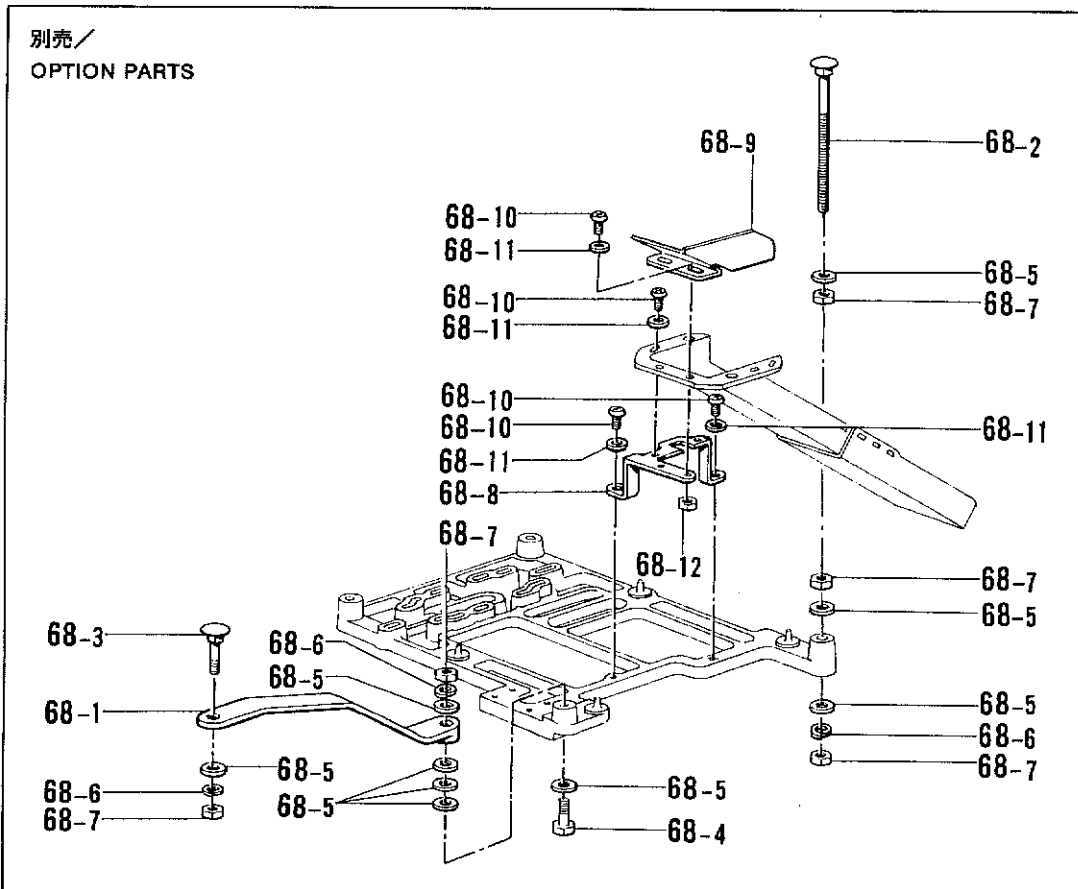
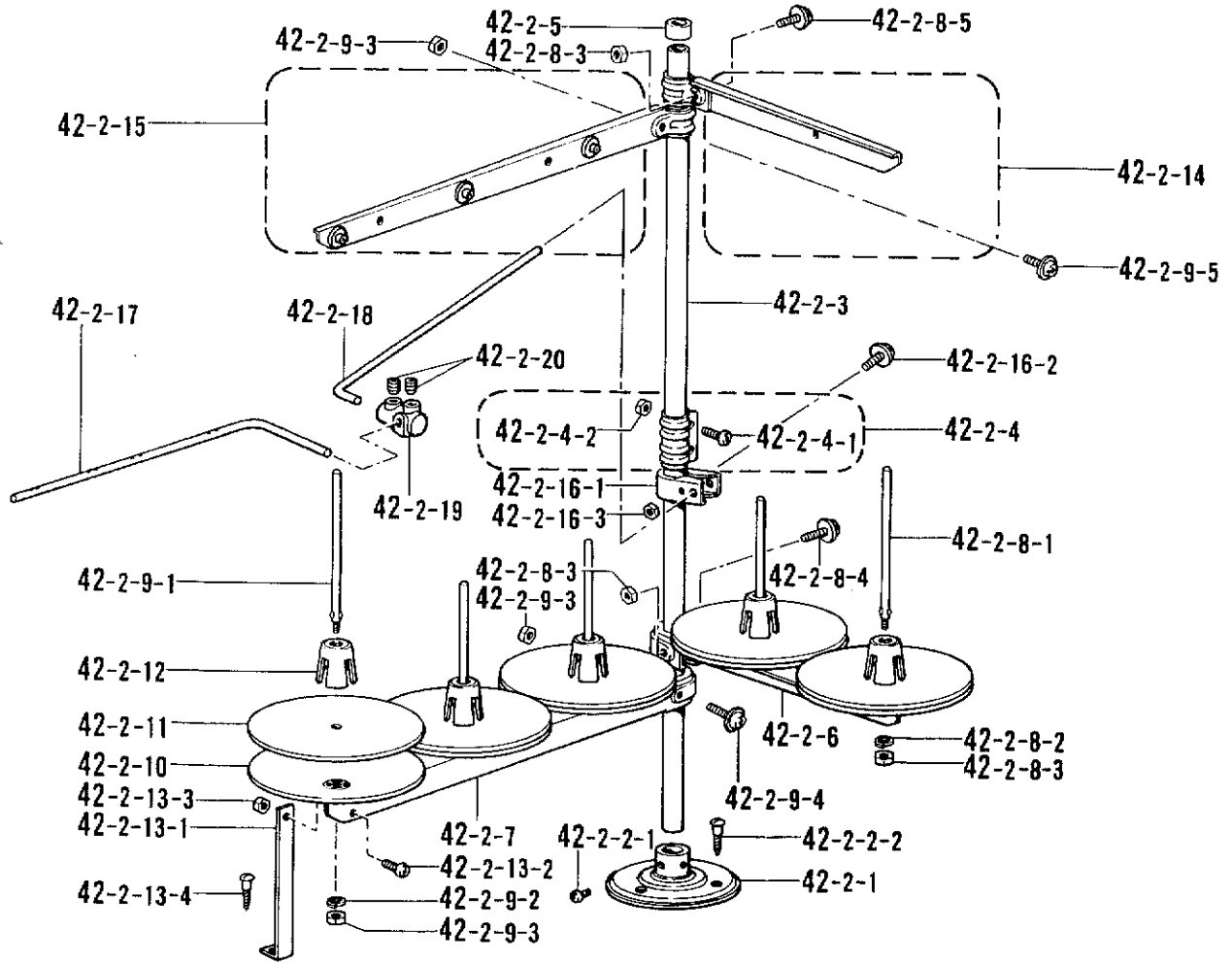

Z. 付属品関係 / Accessories / Zubehör / Accessoires / Accesorios

REF.NO.	CODE	Q'TY	ヒンメイ	NAME OF PARTS	RMKS
42-2	S02770101	1	イトタテタ"イクミ5THF	COTTON STAND ASSEMBLY 5THF	
42-2-1	150189002	1	フ"ラケット	COTTON STAND BASE	
42-2-2	S02773001	1	フ"ラケットネシ"セット	COTTON STAND BASE SCREW SET	
42-2-2-1	062060806	2	ナヘ"コ6X8	SCREW 6X8	
42-2-2-2	031452206	3	マルモク45X22	SCREW 45X22	
42-2-3	150172002	2	コラムパイプ	COLUMN PIPE	
42-2-4	150106002	1	コラムシ"ョイントクミ	COLUMN JOINT ASSEMBLY	
42-2-4-1	062501406	2	ナヘ"コ5X14	SCREW 5X14	
42-2-4-2	021500106	2	1シユナツト5	NUT 5	
42-2-5	150174000	1	コラムキャップ	COLUMN CAP	
42-2-6	S02778001	1	スプ"ールホルタ"-2	SPOOL HOLDER 2	
42-2-7	S02779001	1	スプ"ールホルタ"-3	SPOOL HOLDER 3	
42-2-8	S02780001	1	スプ"ールネシ"セット2	SPOOL SCREW SET 2	
42-2-8-1	150179002	2	スプ"ールシ"クB	SPOOL SHAFT (B)	
42-2-8-2	028050246	2	ハ"ネサ"ガ"ネ2-5	SPRING WASHER 2-5	
42-2-8-3	021500106	4	1シユナツト5	NUT 5	
42-2-8-4	050503006	1	ナヘ"コヒラサ"5X30	SCREW 5X30	
42-2-8-5	050501406	1	ナヘ"コヒラサ"5X14	SCREW 5X14	
42-2-9	S02782001	1	スプ"ールネシ"セット3	SPOOL SHAFT SET	
42-2-9-1	150179002	3	スプ"ールシ"クB	SPOOL SHAFT (B)	
42-2-9-2	028050246	3	ハ"ネサ"ガ"ネ2-5	SPRING WASHER 2-5	
42-2-9-3	021500106	5	1シユナツト5	NUT 5	
42-2-9-4	050503006	1	ナヘ"コヒラサ"5X30	SCREW 5X30	
42-2-9-5	050501406	1	ナヘ"コヒラサ"5X14	SCREW 5X14	
42-2-10	150180000	5	ウケサ"ラ	SPOOL STAND BASE	
42-2-11	150182000	5	スプ"ールマット	SPOOL MAT	
42-2-12	126863001	5	スプ"ールクツシヨ	SPOOL CUSHION	
42-2-13	S02784001	1	ホルタ"-ササエAセット	SPOOL HOLDER SUPPORTER (A) SET	
42-2-13-1	150188002	1	スプ"ールホルタ"-ササエA	SPOOL HOLDER SUPPORTER (A)	
42-2-13-2	062501006	1	ナヘ"コ5X10	SCREW 5X10	
42-2-13-3	021500106	1	1シユナツト5	NUT 5	
42-2-13-4	031452206	1	マルモク45X22	SCREW 45X22	
42-2-14	S02786001	1	スレット"ハンカ"-クミ2	THREAD HANGER ASSEMBLY 2	
42-2-15	S02788001	1	スレット"ハンカ"-クミ3	THREAD HANGER ASSEMBLY 3	
42-2-16	150145002	1	イトアンナイホルタ"-クミ	THREAD GUIDE HOLDER ASSEMBLY	
42-2-16-1	150185002	1	イトアンナイホルタ"-	THREAD GUIDE HOLDER	
42-2-16-2	050503006	1	ナヘ"コヒラサ"5X30	SCREW 5X30	
42-2-16-3	021500106	1	1シユナツト5	NUT 5	
42-2-17	142999001	1	イトアンナイ5	THREAD GUIDE 5	
42-2-18	S04109001	1	イトアンナイササエホ"ウ	THREAD GUIDE SUPPORTER BAR	
42-2-19	138843001	1	ササエホ"ウツキ"テ	JOINT	
42-2-20	014060632	2	アナトメ6X6クホ"ミ	SCREW 6X6	

<オプション/OPTION PARTS>

68	S03886001	1	フルサブ"マージ"セット	FULL-SUBMERGED SET	
68-1	153319001	1	トウフ"ウケササエ	HEAD PLATE SUPPORTER	
68-2	153318101	3	カクネマルアタマホ"ルト	BOLT	
68-3	211964001	1	カクネホ"ルト8X55	BOLT 8X55	
68-4	017085502	1	ホ"ルトM8X55	BOLT 8X55	
68-5	025080236	15	ヒラサ"ガ"ネチュウ8	WASHER 8	
68-6	028080242	5	ハ"ネサ"ガ"ネ2-8	SPRING WASHER 2-8	
68-7	021080106	11	ナツト1シユ8	NUT 8	
68-8	S03889001	1	ダ"スターシュートササエ	DUSTER SHOOT SUPPORTER	
68-9	S03890001	1	ダ"スタート"ロップ	DUSTER DROP	
68-10	062681212	6	ナヘ"コ437-40X12	SCREW 437X12	
68-11	025680232	6	ヒラサ"ガ"ネチュウ4.37	WASHER 4.37	
68-12	021680202	2	ナツト2シユ4.37	NUT 4.37	

* 付属品の明細は変更することがあります。

* The details of included accessories are subject to change.

* Änderungen in der Aufstellung der Mitgelieferten Zubehöre sind vorbehalten.

* Les détails des accessoires inclus sont sujets à des changements.

* Los detalles de los accesorios incluidos pueden variar.

仕様別部品一覧表 / DIFFERENT PARTS LIST / ZUBEHÖRLISTE /
 LISTE DES PIÈCES ACCESSOIRES / LISTA DE PIEZAS ACCESORIAS

SUB CLASS	サンショウ パンゴウ REF.NO.	A-75	A-76	A-79	A-82	A-83	D-21	D-22
	ヒンメイ PARTS ショウ SPEC	オイルニガシグチ OIL HOLE BOLT FOR OIL GAUGE	イトオシセツメイタ THREADING DIAGRAM	ショウラヘル LABEL	ショウラヘル LABEL	ルーパイトチョウセツ ラヘル LABEL	ハリトメクミ NEEDLE CLAMP ASSEMBLY	ミシンハリDCX1 NEEDLE DCX1
061-2				146976081				
-3	イッパンジヌイヨウ	143196001	146463001	146976001	-----	147943001	146487001	112297011
-4	THIN			146976002				(コスト:1)
-5				146976003				(Q'TY:1)
062-3								
	イッパンジヌイヨウ	↑	146464001	146976004	-----	-----	↑	↑
	THIN							
063-3				146976007				
-4	イッパンジヌイヨウ	↑	146463001	146976008	-----	147943001	146489001	112297014
-5	THIN MEDIUM			146976009				(コスト:1)
								(Q'TY:1)
064-3				146976010				
-4	イッパンジヌイヨウ	↑	146464001	146976011	-----	-----	↑	↑
-5	THIN MEDIUM			146976012				
065-5				146976013				
-6	イッパンジヌイヨウ	↑	146463001	146976014	-----	147943001	146491001	112297016
	THICK							(コスト:1)
								(Q'TY:1)
066-5								
	イッパンジヌイヨウ	↑	146464001	146976016	-----	-----	↑	↑
	THICK							
067-4				146976019				
-5	ラフラーヨウ	-----	146463001	146976097	-----	147943001	146487001	112297014
	RUFFLING							(コスト:1)
								(Q'TY:1)
069-5								
	ラフラーヨウ	-----	↑	146976021	-----	↑	146489001	↑
	RUFFLING							
071-5				148976088				
-6	ラフラーヨウ	-----	↑	146976023	-----	↑	146491001	↑
	RUFFLING							

SUB CLASS	サンショウ ハンゴウ REF.NO.	A-75	A-76	A-79	A-82	A-83	D-21	D-22
	ヒンメイ PARTS ショウ SPEC	オイルニガシグチ OIL HOLE BOLT FOR OIL GAUGE	イトオシセツメイイタ THREADING DIAGRAM	シヨウラベル LABEL	シヨウラベル LABEL	ルーパイトショウセツ ラベル LABEL	ハリトメクミ NEEDLE CLAMP ASSEMBLY	ミシンハリDCX1 NEEDLE DCX1
073-4	ハイピング" ラフラーヨウ RUFFLING W/PIPING	-----	146463001	146976025	-----	147943001	146487001	112297014 (コスト:1) (Q'TY:1)
074-4	ハイピング" ラフラーヨウ RUFFLING W/PIPING	-----	146464001	146976026	-----	-----	↑	↑
075-5	ハイピング" ラフラーヨウ RUFFLING W/PIPING	-----	146463001	146976027	-----	147943001	146489001	↑
076-5	ハイピング" ラフラーヨウ RUFFLING W/PIPING	-----	146464001	146976028	-----	-----	↑	↑
077-5 -6	ハイピング" ラフラーヨウ RUFFLING W/PIPING	-----	146463001	146976029	-----	147943001	146491001	↑
079-4	テープヨウ TAPING	143196001	↑	146976032	-----	↑	146487001	112297011 (コスト:1) (Q'TY:1)
081-3 -4 -5	テープヨウ TAPING	↑	↑	146976037 146976038 146976039	-----	↑	146489001	112297014 (コスト:1) (Q'TY:1)
083-5 -6	テープヨウ TAPING	↑	↑	146976043 146976044	-----	↑	146491001	112297016 (コスト:1) (Q'TY:1)
084-6	テープヨウ TAPING	↑	146464001	146976047	-----	-----	↑	↑

SUB CLASS	サンショウ ハンゴウ REF.NO.	A-75	A-76	A-79	A-82	A-83	D-21	D-22
	ヒンメイ PARTS ショウ SPEC	オイルニガシクチ OIL HOLE BOLT FOR OIL GAUGE	イトオシセツメイタ THREADING DIAGRAM	シヨウラヘル LABEL	シヨウラヘル LABEL	ルーハイトショウセツ ラヘル LABEL	ハリトメクミ NEEDLE CLAMP ASSEMBLY	ミシンハリDCX1 NEEDLE DCX1
085-3 -5	テニムヨウ HEAVY	143196001	146463001	-----	151488012 151488018	147943001	146489001	112297018 (コスト:1) (Q'TY:1)
087-5 -6	テニムヨウ HEAVY	↑	↑	146976080 146976051	-----	↑	146491001	↑
089-5	ハインディング ヨウ BINDING	↑	↑	146976069	-----	↑	146489001	112297014 (コスト:1) (Q'TY:1)
090-5	ハインディング ヨウ BINDING	↑	146464001	146976098	-----	-----	↑	↑
092-5 -6 -7	テニムヨウ HEAVY	↑	146463001	146976089 146976090 -----	----- ----- 151488019	147943001	146491001	112297018 (コスト:1) (Q'TY:1)
093-6	テニムヨウ HEAVY	↑	146464001	146976092	-----	-----	↑	↑

SUB CLASS	サンショウ パンゴウ REF.NO.	A-75	A-76	A-79	A-82	A-83	D-21	D-22
	ヒンメイ PARTS ショウ SPEC	オイルニカシクチ OIL HOLE BOLT FOR OIL GAUGE	イトトオシセツメイイタ THREADING DIAGRAM	シヨウラヘル LABEL	シヨウラヘル LABEL	ルーパイトショウセツ ラヘル LABEL	ハリトメクミ NEEDLE CLAMP ASSEMBLY	ミシンハリDCX1 NEEDLE DCX1
094-5 -7	イッパンジヌイヨウ THIN MEDIUM	143196001	146463001	-----	151488002 151488003	147943001	151467001	112297011 (コスウ:1) (Q'TY:1)
095-5	イッパンジヌイヨウ THIN MEDIUM	↑	156523001	-----	151488015	↑	156500001	112297016 (コスウ:2) (Q'TY:2)
096-5	ハルキーニットヨウ BULKY NIT	↑	S01796001	-----	151488021	↑	S01957001	112297014 (コスウ:2) (Q'TY:2)
097-5	ハルキーニットヨウ BULKY NIT	↑	↑	-----	151488022	↑	S01945001	↑

SUB CLASS	サンショウ ハンゴウ REF.NO.	D-23	D-38	F-67	F-68	F-69	Z-1-1	Z-1-2
	ヒンメイ PARTS ショウ SPEC	ミシンハリDMX13 NEEDLE DMX13	ハリイタ NEEDLE PLATE	シュオクリハ MAIN FEED DOG	サト"ウオクリハ" DIFFEREN- TIAL FEED DOG	ホジ"ヨオクリハ" CHAIN FEED DOG	ミシンハリDCX1 NEEDLE DCX1	ミシンハリDMX13 NEEDLE DMX13
061-2			148280001					
-3	イッパ"ンシ"ヌイヨウ	140104011	146498001	146567001	146572001	146577001	112297011	140104011
-4	THIN		146499001					
-5			146500001					
062-3								
	イッパ"ンシ"ヌイヨウ	↑	146498001	↑	↑	↑	↑	↑
	THIN							
063-3			146501001					
-4	イッパ"ンシ"ヌイヨウ	140104014	146502001	↑	↑	↑	112297014	140104014
-5	THIN MEDIUM		146503001					
064-3			146501001					
-4	イッパ"ンシ"ヌイヨウ	↑	146502001	↑	↑	↑	↑	↑
-5	THIN MEDIUM		146503001					
065-5			146504001					
-6	イッパ"ンシ"ヌイヨウ	140104016	146505001	146568001	146573001	↑	112297016	140104016
	THICK							
066-5			146504001					
	イッパ"ンシ"ヌイヨウ	↑	146504001	↑	↑	↑	↑	↑
	THICK							
067-4			S01770001					
-5	ラフラーヨウ	140104014	S01771001	S01777001	146575001	146578001	112297014	140104014
	RUFFLING							
069-5								
	ラフラーヨウ	↑	S01773001	↑	↑	↑	↑	↑
	RUFFLING							
071-5			S01774001					
-6	ラフラーヨウ	↑	S01775001	S01778001	146576001	↑	↑	↑
	RUFFLING							

SUB CLASS	サンショウ パンゴウ REF.NO.	D-23	D-38	F-67	F-68	F-69	Z-1-1	Z-1-2
	ヒンメイ PARTS ショウ SPEC	ミシンハリDMX13 NEEDLE DMX13	ハリイタ NEEDLE PLATE	シュオクリハ" MAIN FEED DOG	サト"ウオクリハ" DIFFEREN- TIAL FEED DOG	ホシ"ヨオクリハ" CHAIN FEED DOG	ミシンハリDCX1 NEEDLE DCX1	ミシンハリDMX13 NEEDLE DMX13
073-4	ハイビヅク" ラフラーヨウ RUFFLING W/PIPING	140104014	S01770001	S01779001	146575001	146578001	112297014	140104014
074-4	ハイビヅク" ラフラーヨウ RUFFLING W/PIPING	↑	↑	↑	↑	↑	↑	↑
075-5	ハイビヅク" ラフラーヨウ RUFFLING W/PIPING	↑	S01773001	S01780001	↑	↑	↑	↑
076-5	ハイビヅク" ラフラーヨウ RUFFLING W/PIPING	↑	↑	↑	↑	↑	↑	↑
077-5 -6	ハイビヅク" ラフラーヨウ RUFFLING W/PIPING	↑	S01774001 S01775001	S01776001	146576001	↑	↑	↑
079-4	テープヨウ TAPING	140104011	146499001	146567001	146572001	146577001	112297011	140104011
081-3 -4 -5	テープヨウ TAPING	140104014	146501001 146502001 146503001	↑	↑	↑	112297014	140104014
083-5 -6	テープヨウ TAPING	140104016	146504001 146505001	146568001	146573001	↑	112297016	140104016
084-6	テープヨウ TAPING	↑	146505001	↑	↑	↑	↑	↑

SUB CLASS	サンショウ パンゴウ REF.NO.	D-23	D-38	F-67	F-68	F-69	Z-1-1	Z-1-2
	ヒンメイ PARTS ショウ SPEC	ミシンハリDMX13 NEEDLE DMX13	ハリイタ NEEDLE PLATE	シュオクリハ MAIN FEED DOG	サトウオクリハ DIFFEREN- TIAL FEED DOG	ホシヨオクリハ CHAIN FEED DOG	ミシンハリDCX1 NEEDLE DCX1	ミシンハリDMX13 NEEDLE DMX13
085-3 -5	デニムヨウ HEAVY	140104018	148978001 S09473001	148980001	148981001 S00878001	146577001	112297018	140104018
087-5 -6	デニムヨウ HEAVY	↑	147783001 146510001	146569001	146574001	↑	↑	↑
089-5	ハインディング ヨウ BINDING	140104014	147369001	146567001	146572001	↑	112297014	140104014
090-5	ハインディング ヨウ BINDING	↑	↑	↑	↑	↑	↑	↑
092-5 -6 -7	デニムヨウ HEAVY	140104018	147783001 146510001 158740001	146569001	146574001	↑	112297018	140104018
093-6	デニムヨウ HEAVY	↑	146510001	↑	↑	↑	↑	↑

SUB CLASS	サンショウ ハンゴウ REF.NO.	D-23	D-38	F-67	F-68	F-69	Z-1-1	Z-1-2
	ヒンメイ PARTS ショウ SPEC	ミシンハリDMX13 NEEDLE DMX13	ハリイタ NEEDLE PLATE	シュオクリハ" MAIN FEED DOG	サト"ウオクリハ" DIFFEREN- TIAL FEED DOG	ホシ"ヨオクリハ" CHAIN FEED DOG	ミシンハリDCX1 NEEDLE DCX1	ミシンハリDMX13 NEEDLE DMX13
094-5 -7	イッパハンジ"ヌイヨウ THIN MEDIUM	140104011	151472001 151473001	151469001	151470001	146577001	112297011	140104011
095-5	イッパハンジ"ヌイヨウ THIN MEDIUM	140104016	156502001	146568001	146573001	↑	112297016	140104016
096-5	ハ"ルキーニットヨウ BULKY NIT	140104014	S02863001	S02867001	S02865001	↑	112297014	140104014
097-5	ハ"ルキーニットヨウ BULKY NIT	↑	S02864001	S02868001	S02866001	↑	↑	↑

CODE	REF.NO.	PAGE
11229701	Z - 1-1	44
S00049001	D - 14-1	8
S00878001	F - 68	22
S01223001	G - 1-1	24
S01225001	P - 1-1	36
S01248101	M - 13-1	32
S01295001	E - 35-1-6	12
	E - 35-10-6	14
	E - 35-16-6	18
	E - 35-17-6	18
	P - 32	36
S01297001	F - 73	22
S01304001	H - 2	28
S01371001	E - 35-13-4	16
	E - 35-15-4	16
S01372001	E - 35-15-3	16
S01373001	E - 35-13-2	16
	E - 35-15-2	16
S01374001	E - 35-13-5	16
	E - 35-15-5	16
S01375001	E - 35-13-1	16
	E - 35-15-1	16
S01385001	E - 35-13-3	16
S01417001	D - 19	8
S01597001	N - 9-2	34
S01614001	H - 1-1-31	26
	H - 1-2-31	28
S01652001	D - 14	8
S01654000	D - 14-2	8
S01756001	P - 30	36
S01757001	P - 31-1	36
S01758001	D - 41	8
S01759101	E - 35-20	18
S01761001	P - 31-2	36
S01762101	E - 35-19	18
S01770001	D - 38	8
S01771001	D - 38	8
S01773001	D - 38	8
S01774001	D - 38	8
S01775001	D - 38	8
S01776001	F - 67	22
S01777001	F - 67	22
S01778001	F - 67	22
S01779001	F - 67	22
S01780001	F - 67	22
S01790001	B - 1-2	6
S01796001	A - 76	4
S01943001	Z - 7	44
S01945001	D - 21	8
S01947101	D - 24-2	8
S01948001	D - 42	8
S01950001	E - 35-19-2	18
	E - 35-20-2	18
S01951001	E - 35-19-12	18
	E - 35-20-12	18
S01957001	D - 21	8
S02770101	Z - 42-2	48
S02772101	Z - 42-1	46
S02773001	Z - 42-1-2	46
	Z - 42-2-2	48
S02778001	Z - 42-2-6	48
S02779001	Z - 42-1-6	46
	Z - 42-2-7	48
S02780001	Z - 42-2-8	48
S02782001	Z - 42-1-7	46
	Z - 42-2-9	48
S02783001	Z - 42-1-15	46

CODE	REF.NO.	PAGE
S02784001	Z - 42-1-11	46
	Z - 42-2-13	48
S02785001	Z - 42-1-12	46
S02786001	Z - 42-2-14	48
S02788001	Z - 42-1-13	46
	Z - 42-2-15	48
S02863001	D - 38	8
S02864001	D - 38	8
S02865001	F - 68	22
S02866001	F - 68	22
S02867001	F - 67	22
S02868001	F - 67	22
S02874001	C - 12-1-4	6
	C - 12-2-5	6
S03321001	E - 33	10
S03886001	Z - 68	48
S03887201	A - 62	4
S03888000	Z - 27	44
S03889001	Z - 68-8	48
S03890001	Z - 68-9	48
S04109001	Z - 42-1-16	46
	Z - 42-2-18	48
S05721003	F - 1-18	20
S06294001	N - 6	34
S06561001	E - 4	10
S06701000	Z - 18	44
S06704001	Z - 39	44
S07293001	R - 61	42
S07848001	B - 1-3	6
S09323001	A - 84	4
S09456001	D - 44	8
S09459001	D - 46-1	8
S09460001	D - 46-2	8
S09473001	D - 38	8
S09565001	E - 35-19-8	18
	E - 35-20-8	18
S10774001	D - 18-2	8
	N - 14-2	34
S11072001	F - 8	20
S12677001	H - 1-2	26
013679412	H - 1-1-29	26
	H - 1-2-29	28
013719412	B - 21	6
013760612	M - 10-1	32
013761410	B - 18	6
014060632	Z - 42-1-18	46
	Z - 42-2-20	48
014680422	A - 87	4
	E - 29	10
	M - 14	32
	N - 13-1-7	34
	N - 13-2-7	34
	N - 15-1-1	34
	N - 15-2-1	34
	N - 15-3-1	34
	P - 26	36
	R - 52	42
014770622	F - 31	20
	P - 1-2	36
	P - 5-1	36
	Q - 2	38
	R - 2	40
014780622	H - 14-6	28
017085502	Z - 68-4	48
017771412	F - 36	22
	F - 44-2	22
	F - 52-1	22

CODE	REF.NO.	PAGE
017771412	G - 11	24
	N - 3	34
017771612	A - 65	4
	D - 2	8
	E - 22	10
	F - 6	20
	F - 61	22
	G - 1-5	24
	M - 3	32
	P - 2	36
	P - 9	36
017781012	H - 14-10	28
	H - 14-13	28
	H - 14-4	28
018061622	D - 25	8
021080106	Z - 33	44
	Z - 68-7	48
021400106	Z - 21	44
021500106	Z - 42-1-11-3	46
	Z - 42-1-12-3	46
	Z - 42-1-14-3	46
	Z - 42-1-4-2	46
	Z - 42-1-7-3	46
	Z - 42-2-13-3	48
	Z - 42-2-16-3	48
	Z - 42-2-4-2	48
	Z - 42-2-8-3	48
	Z - 42-2-9-3	48
021670202	A - 50	4
021680202	Z - 68-12	48
025030232	E - 35-13-7	16
	E - 35-15-7	16
	Z - 61-3	44
025050236	Z - 59	44
025080236	Z - 31	44
	Z - 68-5	48
025350332	L - 8	32
	Q - 3-2	38
025680232	Z - 68-11	48
025770232	F - 70	22
	H - 1-1-8	26
	H - 1-2-8	26
028050242	J - 1-1-3	30
	R - 62	42
028050246	Z - 42-1-7-2	46
	Z - 42-2-8-2	48
	Z - 42-2-9-2	48
028080242	Z - 32	44
	Z - 68-6	48
031311302	Z - 37	44
031452206	Z - 42-1-11-4	46
	Z - 42-1-12-4	46
	Z - 42-1-2-2	46
	Z - 42-2-13-4	48
	Z - 42-2-2-2	48
032422505	H - 17-2	28
047140842	A - 28-1-4	2
	A - 28-2-4	2
047300842	E - 6	10
047301440	N - 13-1-6	34
	N - 13-2-6	34
047502242	F - 58	22
048025342	E - 35-11-6	16
	E - 35-12-6	16
	E - 35-14-6	16
	E - 35-18-6	18
	E - 35-19-6	18

CODE	REF.NO.	PAGE
048025342	E - 35-2-6	12
	E - 35-20-6	18
	E - 35-3-6	12
048040342	F - 9	20
048080342	E - 19	10
048150143	F - 1-12	20
050501406	Z - 42-1-7-5	46
	Z - 42-2-8-5	48
	Z - 42-2-9-5	48
050503006	Z - 42-1-14-2	46
	Z - 42-1-7-4	46
	Z - 42-2-16-2	48
	Z - 42-2-8-4	48
	Z - 42-2-9-4	48
060630312	R - 37	40
060630412	E - 35-19-3	18
	E - 35-20-3	18
	R - 57	42
060670512	A - 40	2
	A - 42	2
	H - 1-1-27	26
	H - 1-2-27	26
060670812	R - 18	40
060680512	A - 29	2
	D - 27	8
	D - 29	8
062060806	Z - 42-1-2-1	46
	Z - 42-2-2-1	48
062401406	Z - 22	44
062501006	Z - 42-1-11-2	46
	Z - 42-1-12-2	46
	Z - 42-2-13-2	48
062501406	Z - 42-1-4-1	46
	Z - 42-2-4-1	48
062630812	F - 66	22
062660412	E - 38	10
	M - 5	32
	N - 5	34
	P - 4	36
	R - 16	40
	R - 22	40
	Z - 50	44
062660512	F - 1-8	20
	Z - 61-2	44
062660612	E - 35-13-8	16
	E - 35-15-8	16
062660712	E - 35-4-3	12
	E - 35-5-3	12
	E - 35-6-3	14
	E - 35-7-3	14
	E - 35-8-3	14
	E - 35-9-3	14
	F - 44-1	22
	H - 1-1-14	26
	H - 1-2-14	26
062670412	A - 28-1-7	2
	A - 28-2-7	2
	D - 43	8
	R - 55	42
062670512	L - 2	32
	L - 4	32
062670612	A - 20	2
	A - 26	2
	A - 31	2
	A - 48	2
	A - 61	4
	A - 71	4

CODE	REF.NO.	PAGE	
062670612	D - 35	8	
	F - 11	20	
	G - 20	24	
	H - 13	28	
	Q - 17	38	
	R - 25	40	
	R - 28	40	
	R - 30	40	
	R - 35	40	
	R - 39	40	
	R - 43	42	
	R - 60	42	
	062670812	B - 5-1	6
		B - 5-2	6
		D - 10	8
		D - 33	8
		D - 47	8
F - 19		20	
Q - 3-3		38	
R - 33		40	
062671012		G - 9-2	24
		Q - 3-10	38
062671412	A - 49	4	
	D - 45	8	
062680612	H - 1-1-25	26	
	H - 1-2-25	26	
062680712	L - 6	32	
	A - 23	2	
	A - 52	4	
	A - 8	2	
	D - 18-1	8	
	D - 37	8	
	E - 14	10	
	E - 30	10	
	F - 33	20	
	N - 14-1	34	
062680812	H - 1-1-17	26	
	H - 1-2-17	26	
062681012	B - 14	6	
	C - 2	6	
	F - 25	20	
	F - 28	20	
	H - 17-1	28	
	N - 13-1-5	34	
	N - 13-2-5	34	
	Z - 55-2	44	
	Z - 68-10	48	
	062681212	A - 4	2
E - 34		10	
Q - 4		38	
N - 6-3		34	
B - 4		6	
B - 15		6	
F - 1-17		20	
A - 86		4	
D - 31		8	
J - 1-1-1		30	
062681412	K - 1-4	30	
	F - 4	20	
	C - 13	6	
	G - 5	24	
	N - 12	34	
	F - 56	22	
	D - 1-3	8	
	D - 7	8	
	G - 1-3	24	
	J - 1-1-4	30	

CODE	REF.NO.	PAGE	
100447001	J - 1-2	30	
	100463001	H - 14-8	28
	100645003	A - 53	4
101118001	C - 15	6	
	F - 24	20	
	F - 27	20	
	Z - 55-3	44	
	K - 2	30	
	Z - 58	44	
	Z - 5	44	
	A - 38-1	2	
	F - 34-1	20	
	H - 1-1-18-1	26	
102424004	H - 1-1-4	26	
	H - 1-2-32	28	
	H - 1-2-4	26	
	Q - 3-6-1	38	
	G - 27-2	24	
	B - 6	6	
	G - 14	24	
	A - 19	2	
	D - 17	8	
	L - 7	32	
102538002	H - 1-1-6	26	
	H - 1-2-6	26	
	H - 1-1-22	26	
	H - 1-2-22	26	
	R - 23	40	
	E - 35-11-3	16	
	E - 35-12-3	16	
	E - 35-14-3	16	
	E - 35-18-3	18	
	E - 35-2-3	12	
E - 35-3-3	12		
102627001	E - 35-4-5	12	
	E - 35-5-5	12	
	E - 35-6-5	14	
	E - 35-7-5	14	
	E - 35-8-5	14	
	E - 35-9-5	14	
	Z - 12	44	
	F - 1-1	20	
	B - 12	6	
	G - 12	24	
102744001	G - 27-1	24	
	Z - 10	44	
	K - 1-2	30	
	K - 1-3	30	
	A - 73	4	
	A - 67	4	
	F - 57	22	
	J - 1-1	30	
	J - 1-1-2	30	
	E - 16	10	
10288001	P - 11	36	
	H - 1-1-21	26	
	H - 1-2-21	26	
	A - 66	4	
	B - 9	6	
	B - 13	6	
	B - 16	6	
	B - 11	6	
	M - 4	32	
	N - 4	34	
105234003	L - 10	32	
	P - 16	36	
	E - 18	10	
	105248003		
	105288001		
	105343001		
107093002			
107244001			
107407003			
107779001			
108494001			
108495001			
108960002			
109203001			
109854001			
110161003			
110161006			
110230001			
110641002			
110668001			
110670000			
110672000			
110673000			
110704001			
110735002			
110778002			
110793001			

CODE	REF.NO.	PAGE	
110813001	R - 14-1	40	
	R - 14-2	40	
	R - 44	42	
110820101	H - 1-1-7	26	
	H - 1-2-7	26	
	R - 4-1	40	
	R - 4-2	40	
	R - 4-4	40	
110832001	R - 46	42	
	R - 5-1	40	
111486001	R - 5-2	40	
	A - 24	2	
112297011	D - 30	8	
	D - 22	8	
112297014	Z - 1-1	44	
	D - 22	8	
112297016	Z - 1-1	44	
	D - 22	8	
112297018	Z - 1-1	44	
	D - 22	8	
112299001	R - 70	42	
112300001	R - 68	42	
112301001	H - 8-5	28	
	R - 69	42	
112348001	C - 3	6	
	C - 6	6	
	C - 9	6	
	Q - 11	38	
	Q - 19	38	
	Q - 22	38	
	Q - 24	38	
	Q - 8	38	
	112359001	C - 10	6
		C - 4	6
		C - 7	6
112364001	Q - 25	38	
	Q - 12	38	
	Q - 20	38	
	Q - 23	38	
	Q - 9	38	
112436001	G - 15	24	
	Z - 4	44	
112525000	Q - 58	38	
112735000	Q - 51	38	
112751002	H - 4	28	
	Z - 52	44	
113431002	F - 40	22	
	F - 76	22	
113589001	A - 6	2	
114294001	Q - 37	38	
116016001	Z - 23	44	
117160001	A - 33	2	
117466000	Z - 13	44	
117515001	G - 16	24	
117516001	F - 65	22	
	G - 17	24	
117517003	F - 1-16	20	
118550001	A - 69	4	
118770001	F - 75	22	
120990001	P - 19	36	
122771002	E - 35-11-11	16	
	E - 35-12-11	16	
	E - 35-14-11	16	
	E - 35-18-11	18	
	E - 35-19-11	18	
	E - 35-2-11	12	

CODE	REF.NO.	PAGE
122771002	E - 35-20-11	18
	E - 35-3-11	12
122991001	Z - 25	44
123185001	A - 35	2
126863001	Z - 42-1-10	46
	Z - 42-2-12	48
138843001	Z - 42-1-17	46
	Z - 42-2-19	48
	A - 56	4
140065001	A - 55	4
140066001	B - 10	6
140084000	D - 1-2	8
140088001	D - 5	8
140091000	D - 6	8
140092001	D - 8	8
140093000	D - 9-2	8
140096001	D - 23	8
140104011	Z - 1-2	44
140104014	D - 23	8
	Z - 1-2	44
140104016	D - 23	8
	Z - 1-2	44
140104018	D - 23	8
	Z - 1-2	44
140150000	P - 13	36
140159000	P - 22	36
140165001	F - 1-3	20
140176001	F - 1-15	20
140180001	B - 19	6
140187000	F - 18	20
140188004	F - 17	20
140205001	F - 35	22
140207001	F - 20-2	20
140208001	F - 20-3	20
	F - 20-8	20
140209001	F - 20-4	20
140210001	F - 20-5	20
140217001	F - 20-9	20
140232001	G - 1-2	24
140233001	G - 1-4	24
140235000	G - 6	24
140261001	E - 21	10
140262000	E - 23	10
140263000	E - 24	10
140270001	E - 35-12-1	16
	E - 35-18-1	18
	E - 35-20-1	18
	E - 35-3-1	12
	E - 35-4-1	12
	E - 35-5-1	12
	E - 35-6-1	14
	E - 35-7-1	14
	E - 35-8-1	14
	E - 35-9-1	14
	E - 35-5-6	12
140271001	E - 35-4-7	12
	E - 35-5-7	12
140272001	E - 35-6-7	14
	E - 35-7-7	14
140273001	E - 35-8-7	14
	E - 35-9-7	14
	E - 35-4-8	12
	E - 35-5-8	12
	E - 35-6-8	14
	E - 35-7-8	14
	E - 35-8-8	14
	E - 35-9-8	14

CODE	REF.NO.	PAGE
140275001	E - 35-4-10	12
	E - 35-5-10	12
	E - 35-6-10	14
	E - 35-7-10	14
	E - 35-8-10	14
	E - 35-9-10	14
140313001	P - 17	36
140317000	Q - 47	38
140325001	Q - 15	38
140326001	F - 3	20
140327001	D - 4	8
	F - 14	20
	M - 7	32
	N - 6-2	34
	P - 27	36
140342001	Z - 17	44
140415000	Q - 46	38
140416000	N - 13-1-4	34
	N - 13-2-4	34
140417000	Q - 48	38
140418000	Q - 41	38
140421001	A - 58	4
140759000	Z - 40	44
140778101	Q - 18	38
	Q - 21	38
140779101	Q - 7	38
140780101	Q - 6	38
140888001	Z - 49	44
140991001	E - 35-6-6	14
140992001	E - 35-4-11	12
	E - 35-5-11	12
	E - 35-6-11	14
	E - 35-7-11	14
	E - 35-8-11	14
	E - 35-9-11	14
140993001	E - 35-4-9	12
	E - 35-5-9	12
	E - 35-6-9	14
	E - 35-7-9	14
	E - 35-8-9	14
	E - 35-9-9	14
141183000	A - 37	2
141514001	H - 11	28
	H - 8-2	28
142201001	R - 21-2	40
142243000	E - 35-1-1	12
	E - 35-10-1	14
	E - 35-16-1	18
	E - 35-17-1	18
142244001	E - 35-1-2	12
	E - 35-10-2	14
	E - 35-16-2	18
142245001	E - 35-1-3	12
	E - 35-10-3	14
	E - 35-16-3	18
142246001	E - 35-1-4	12
	E - 35-10-4	14
142247001	E - 35-1-5	12
	E - 35-10-5	14
	E - 35-16-5	18
	E - 35-17-5	18
142250001	E - 35-1	12
142262001	Z - 24	44
142274001	B - 20	6
142669002	R - 36	40
142999001	Z - 42-2-17	48
143179000	B - 8	6

CODE	REF.NO.	PAGE
143196001	A - 75	4
143311001	B - 2-2	6
143312000	B - 3	6
143323103	E - 10-1	10
143325001	E - 12	10
143374001	A - 85	4
143564001	F - 37-1	22
143565001	F - 41	22
143566001	Z - 11	44
143757001	R - 15-1	40
143767002	K - 1	30
143980001	K - 1-1	30
143992001	A - 9	2
144025001	N - 1	34
144029000	N - 8	34
144031000	N - 10	34
144044001	M - 1	32
144053001	F - 1-9	20
144055001	F - 1-10	20
144068001	F - 37-2	22
144074000	G - 8-1	24
144075001	G - 9-1	24
144079001	E - 1	10
144081001	E - 3	10
144083001	E - 5	10
144085001	E - 8	10
144086001	E - 9	10
144103002	R - 7-1	40
	R - 7-2	40
144104001	R - 8-1	40
	R - 8-3	40
144105000	H - 1-1-10	26
	H - 1-2-10	26
	R - 11	40
	R - 49	42
144108001	R - 21-1	40
144110001	R - 10	40
144111001	R - 26	40
144116000	C - 12-1-2	6
	C - 12-2-2	6
144117000	G - 7	24
144127001	D - 32	8
144179001	G - 26-1	24
144225002	Z - 41	44
144619000	Q - 3-1	38
144622001	Q - 3-5	38
144764001	H - 1-1-26	26
	H - 1-2-26	26
144775001	E - 35-5	12
144777001	E - 35-4-2	12
	E - 35-5-2	12
	E - 35-6-2	14
	E - 35-7-2	14
	E - 35-8-2	14
	E - 35-9-2	14
144778001	E - 35-4-4	12
	E - 35-5-4	12
	E - 35-6-4	14
	E - 35-7-4	14
	E - 35-8-4	14
	E - 35-9-4	14
144783001	H - 1-1-12	26
	H - 1-2-12	26
144784001	H - 1-1-13	26
	H - 1-2-13	26
144788001	H - 1-1-9	26
	H - 1-2-9	26

CODE	REF.NO.	PAGE
144793000	H - 3	28
	Z - 51	44
145147001	E - 35-11-2	16
	E - 35-12-2	16
	E - 35-18-2	18
	E - 35-2-2	12
	E - 35-3-2	12
145277105	Z - 19	44
145446001	R - 47	42
	R - 6-1	40
	R - 6-2	40
145663001	F - 1-2	20
145664000	Q - 32	38
145803001	H - 1-1-2	26
	H - 1-2-2	26
145807001	H - 1-1-16	26
	H - 1-2-16	26
145808001	H - 1-1-24	26
	H - 1-2-24	26
145809001	H - 5	28
145810001	H - 1-1-19	26
	H - 1-2-19	26
145811001	H - 1-1-23	26
	H - 1-2-23	26
146315000	A - 57	4
146401001	F - 1-4	20
146402001	F - 1-5	20
146403001	F - 1-6	20
146404001	F - 1-7	20
146419001	A - 2	2
146420000	A - 3	2
146421000	A - 5	2
146422001	A - 7	2
146425001	A - 13	2
146426000	A - 14	2
146427001	A - 15	2
	D - 11	8
	D - 21-1	8
146428001	A - 16-1	2
146430001	A - 16-3	2
146432001	A - 17	2
146433000	A - 18	2
146434000	A - 21	2
146435000	A - 22	2
146436001	A - 25	2
146440001	A - 28-1-1	2
	A - 28-2-1	2
146441000	A - 28-1-2	2
	A - 28-2-2	2
146442001	A - 28-1-3	2
	A - 28-2-3	2
146443001	A - 30	2
146444001	A - 32-1	2
146449001	A - 39	2
146450001	A - 41	2
146451001	A - 43	2
146452001	A - 44	2
146453001	A - 46	2
146454001	A - 47	2
146455101	A - 51-1	4
146457001	A - 60	4
146460001	A - 70	4
146463001	A - 76	4
146464001	A - 76	4
146471001	B - 1-1	6
146473001	B - 7	6
146476101	D - 1	8

CODE	REF.NO.	PAGE
146478001	D - 1-4	8
146479001	D - 3	8
146480001	D - 9	8
146482001	D - 9-3	8
146483001	D - 12	8
146487001	D - 21	8
146489001	D - 21	8
146491001	D - 21	8
146493102	D - 24-1	8
146494001	D - 26	8
146495001	D - 28	8
146496301	D - 34	8
146497201	D - 36	8
146498001	D - 38	8
146499001	D - 38	8
146500001	D - 38	8
146501001	D - 38	8
146502001	D - 38	8
146503001	D - 38	8
146504001	D - 38	8
146505001	D - 38	8
146510001	D - 38	8
146511100	C - 1	6
146512101	C - 5	6
146515000	C - 8	6
146516000	C - 11	6
146517100	C - 12-1	6
146518100	C - 12-1-1	6
146521001	E - 2	10
146522001	E - 13-1	10
146523001	E - 17	10
146524001	E - 20	10
146525001	E - 25	10
146526001	E - 27	10
146527001	E - 28	10
146528001	F - 1	20
146529001	F - 1-11	20
146530001	F - 1-13	20
146531001	F - 1-14	20
146532001	F - 2	20
146533001	F - 5	20
146534001	F - 7	20
146536001	F - 10	20
146537000	F - 12	20
146538001	F - 13	20
146539000	F - 15	20
146540000	F - 16	20
146541001	F - 20-1	20
146544000	F - 20-1-2	20
146547000	F - 29	20
146548101	F - 30	20
146549001	F - 32	20
146550001	F - 44	22
146554001	F - 20-6	20
146555001	F - 20-7	20
146556001	F - 49	22
146558001	F - 53	22
146559001	F - 54	22
146560101	F - 55	22
146561001	F - 59-1	22
146562001	F - 59-3	22
146563001	F - 60	22
146564001	F - 62	22
146565001	F - 63	22
146566001	F - 64	22
146567001	F - 67	22
146568001	F - 67	22

CODE	REF.NO.	PAGE
146569001	F - 67	22
146572001	F - 68	22
146573001	F - 68	22
146574001	F - 68	22
146575001	F - 68	22
146576001	F - 68	22
146577001	F - 69	22
146578001	F - 69	22
146580001	G - 24	24
146581001	G - 4	24
	N - 11	34
146582001	G - 10	24
146583001	G - 13	24
146584001	G - 18	24
146585001	G - 19	24
146586000	G - 21	24
146587201	H - 1-1	26
146588001	H - 1-1-1	26
	H - 1-2-1	26
146589001	H - 1-1-3	26
	H - 1-2-3	26
146590001	H - 1-1-5	26
	H - 1-2-5	26
146592001	H - 1-1-28	26
	H - 1-2-28	26
146594001	H - 16	28
146602001	N - 9-1	34
146603301	N - 13-1	34
146611301	N - 13-2	34
146614001	M - 6	32
146615000	M - 8	32
146616000	M - 9	32
146617001	M - 11	32
146618001	P - 1	36
146622001	P - 3	36
146624101	P - 7	36
146626001	P - 8	36
146627001	P - 10	36
146628001	P - 12	36
146629000	P - 14	36
146630001	P - 15	36
146631001	P - 18	36
146632001	P - 20	36
146633000	P - 21	36
146635001	P - 25	36
146636201	Q - 13	38
146647001	Q - 1	38
146648001	R - 1	40
146649001	R - 3-1	40
146650001	R - 17	40
146652001	R - 31	40
146653001	R - 32	40
146654001	R - 34	40
146656001	R - 40	40
146663001	R - 56	42
146700001	Z - 8	44
146706001	A - 16-2	2
146717101	A - 51-2	4
146740000	C - 12-2-4	6
146742001	F - 59-2	22
146793001	R - 15-2	40
146865001	E - 35-11-1	16
	E - 35-14-1	16
	E - 35-19-1	18
	E - 35-2-1	12
146869001	E - 35-11-8	16
	E - 35-12-8	16

CODE	REF.NO.	PAGE
146869001	E - 35-14-8	16
	E - 35-18-8	18
	E - 35-2-8	12
	E - 35-3-8	12
146870001	E - 35-11-10	16
	E - 35-12-10	16
	E - 35-14-10	16
	E - 35-18-10	18
	E - 35-19-10	18
	E - 35-2-10	12
	E - 35-20-10	18
	E - 35-3-10	12
146871101	E - 35-2	12
146874101	E - 35-3	12
146878001	E - 35-4	12
146880001	E - 35-4-6	12
146881001	E - 35-6	14
146883001	E - 37	10
146901001	E - 35-11-9	16
	E - 35-12-9	16
	E - 35-14-9	16
	E - 35-18-9	18
	E - 35-2-9	12
	E - 35-3-9	12
146914001	F - 52	22
146924000	A - 32-1-1	2
	A - 32-2-1	2
146925001	R - 38	40
146926002	R - 27	40
146929001	R - 29	40
146930001	R - 59	42
146976001	A - 79	4
146976002	A - 79	4
146976003	A - 79	4
146976004	A - 79	4
146976007	A - 79	4
146976008	A - 79	4
146976009	A - 79	4
146976010	A - 79	4
146976011	A - 79	4
146976012	A - 79	4
146976013	A - 79	4
146976014	A - 79	4
146976016	A - 79	4
146976019	A - 79	4
146976021	A - 79	4
146976023	A - 79	4
146976025	A - 79	4
146976026	A - 79	4
146976027	A - 79	4
146976028	A - 79	4
146976029	A - 79	4
146976032	A - 79	4
146976037	A - 79	4
146976038	A - 79	4
146976039	A - 79	4
146976043	A - 79	4
146976044	A - 79	4
146976047	A - 79	4
146976051	A - 79	4
146976069	A - 79	4
146976080	A - 79	4
146976081	A - 79	4
146976089	A - 79	4
146976090	A - 79	4
146976092	A - 79	4
146976097	A - 79	4











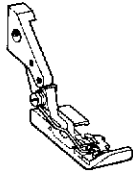
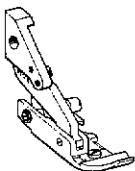
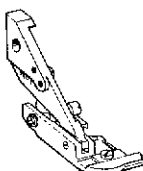
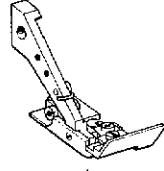

CODE	REF.NO.	PAGE
146976098	A - 79	4
147049001	R - 12-1-2	40
147049002	R - 12-2-2	40
147049003	R - 12-3-1-1-1	40
	R - 12-3-2-1-1	40
147049004	R - 12-4-2	40
147148001	R - 45	42
147149001	R - 48	42
147217000	Q - 31	38
147318000	Q - 52	38
	Q - 56	38
	Q - 57	38
147344001	R - 67-1	42
147361000	Q - 53	38
147363000	Q - 55	38
147367001	A - 32-2	2
147369001	D - 38	8
147370101	E - 35-14	16
147371001	E - 35-14-2	16
147373000	L - 1	32
147377001	L - 3	32
147435001	E - 35-8	14
147437001	E - 35-9	14
147440000	L - 5	32
147454001	E - 13-2	10
147488001	E - 35-8-6	14
147489001	E - 35-9-6	14
147521001	Q - 3	38
147523001	Q - 3-4	38
147527001	Q - 3-7	38
147528100	Q - 3-8	38
147529001	Q - 3-9	38
147672001	H - 12	28
147691000	P - 1-3	36
147773001	F - 20-1-1	20
147783001	D - 38	8
147785001	E - 35-7	14
147787001	E - 35-7-6	14
147848101	B - 17	6
147893003	Z - 20	44
147919001	Z - 48-1	44
147919002	Z - 48-2	44
147933001	H - 1-1-15	26
	H - 1-2-15	26
147934001	N - 15-1	34
147935001	N - 15-3	34
147943001	A - 83	4
147950101	E - 35-11	16
147988001	P - 5	36
148013101	E - 35-15	16
148020001	E - 35-15-6	16
148033001	N - 6-1	34
148034001	N - 6-4	34
148042001	Z - 55-1	44
148084001	A - 54	4
148174000	F - 23	20
148280001	D - 38	8
148281101	G - 25	24
148294001	N - 13-1-2	34
	N - 13-2-2	34
	N - 20	34
	R - 41	40
148343101	G - 28	24
148344001	G - 29	24
148345001	G - 26-2	24
148348001	Z - 55	44
148369101	E - 10-2	10

CODE	REF.NO.	PAGE
148372001	E - 11	10
148379001	N - 13-1-1	34
	N - 13-2-1	34
148387001	H - 1-2-18	26
148388001	H - 8-1	28
148389001	H - 8-3	28
148390001	H - 8-4	28
148391001	H - 10	28
148395001	H - 8	28
148405101	E - 35-12	16
148425001	D - 1-1	8
	G - 1-1-1	24
	M - 1-1	32
	N - 1-1	34
	P - 1-1-1	36
	P - 7-1	36
148427001	G - 1	24
148430101	Z - 36	44
148431201	Z - 56-1	44
148432001	Z - 56-2	44
148782001	M - 15	32
	P - 28	36
148797001	H - 14-5	28
148798001	H - 14-7	28
148815001	G - 8-2	24
148816001	E - 35-10	14
148834001	F - 50	22
148851001	R - 8-2	40
148976088	A - 79	4
148978001	D - 38	8
148979101	E - 35-13	16
148980001	F - 67	22
148981001	F - 68	22
148984001	A - 28-1-5	2
	A - 28-2-5	2
148997001	A - 28-1	2
148999001	A - 28-2	2
149143001	E - 35-13-6	16
149170001	D - 9-1	8
	N - 13-1-3	34
	N - 13-2-3	34
149171001	M - 12	32
	P - 24	36
149173001	Z - 9	44
149260001	E - 35-11-4	16
	E - 35-14-4	16
	E - 35-2-4	12
149261001	E - 35-11-5	16
	E - 35-14-5	16
	E - 35-19-5	18
	E - 35-2-5	12
149262001	E - 35-11-7	16
	E - 35-12-7	16
	E - 35-14-7	16
	E - 35-18-7	18
	E - 35-19-7	18
	E - 35-2-7	12
	E - 35-20-7	18
	E - 35-3-7	12
149265001	E - 35-12-4	16
	E - 35-18-4	18
	E - 35-3-4	12
149266001	E - 35-12-5	16
	E - 35-18-5	18
	E - 35-20-5	18
	E - 35-3-5	12
149267001	E - 39	10

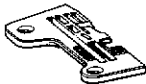
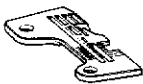
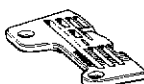
CODE	REF.NO.	PAGE
149566001	H - 1-1-11	26
	H - 1-2-11	26
	R - 12-1-1	40
	R - 12-2-1	40
	R - 12-3-1-1	40
	R - 12-3-2-1	40
	R - 12-4-1	40
149568001	R - 12-1	40
149568002	R - 12-2	40
149568003	R - 12-3-1	40
	R - 12-3-2	40
149568004	R - 12-4	40
149886000	F - 71	22
149887001	F - 72	22
149888000	F - 26	20
150106002	Z - 42-1-4	46
	Z - 42-2-4	48
150145002	Z - 42-1-14	46
	Z - 42-2-16	48
150172002	Z - 42-1-3	46
	Z - 42-2-3	48
150174000	Z - 42-1-5	46
	Z - 42-2-5	48
150179002	Z - 42-1-7-1	46
	Z - 42-2-8-1	48
	Z - 42-2-9-1	48
150180000	Z - 42-1-8	46
	Z - 42-2-10	48
150182000	Z - 42-1-9	46
	Z - 42-2-11	48
150185002	Z - 42-1-14-1	46
	Z - 42-2-16-1	48
150188002	Z - 42-1-11-1	46
	Z - 42-2-13-1	48
150189002	Z - 42-1-1	46
	Z - 42-2-1	48
150194002	Z - 42-1-12-1	46
150307000	Q - 42	38
150550000	Z - 61-1	44
150553002	H - 1-1-20	26
	H - 1-2-20	26
150556002	H - 6	28
150806001	B - 2-1	6
150807101	R - 51	42
150808001	R - 53	42
150810001	R - 54	42
150812001	R - 58	42
150813001	R - 63	42
151012001	R - 50	42
151017001	Z - 61	44
151059001	A - 59	4
151060000	A - 64	4
151461001	E - 35-16	18
151462001	E - 35-17	18
151464001	E - 35-17-2	18
151465001	E - 35-17-3	18
151466001	E - 35-16-4	18
	E - 35-17-4	18
151467001	D - 21	8
151469001	F - 67	22
151470001	F - 68	22
151472001	D - 38	8
151473001	D - 38	8
151475000	C - 12-1-3	6
	C - 12-2-3	6
151488002	A - 82	4
151488003	A - 82	4



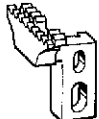
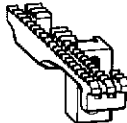
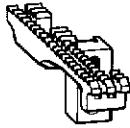
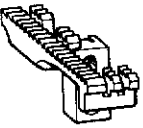
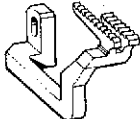
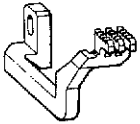
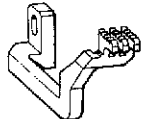
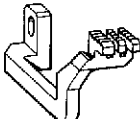







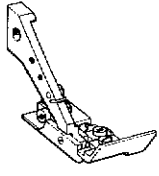
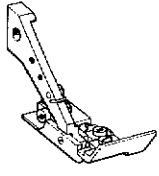
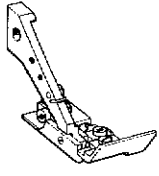
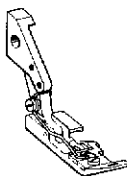

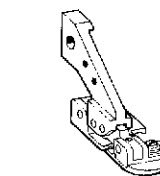
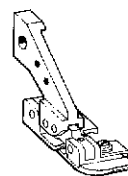
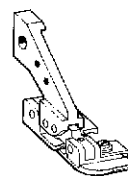







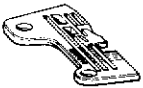

CODE	REF.NO.	PAGE
151488012	A - 82	4
151488015	A - 82	4
151488018	A - 82	4
151488019	A - 82	4
151488021	A - 82	4
151488022	A - 82	4
151488028	A - 82	4
151617001	R - 42	42
152194001	A - 28-1-6	2
	A - 28-2-6	2
153318101	Z - 68-2	48
153319001	Z - 68-1	48
153483001	E - 15	10
153484001	P - 29	36
154795001	H - 1-1-30	26
	H - 1-2-30	28
154829001	A - 34	2
154928000	C - 1-1	6
155103001	E - 35-19-9	18
	E - 35-20-9	18
155196201	H - 14	28
155197001	H - 14-1	28
155198101	H - 14-2	28
155199101	H - 14-3	28
155201101	H - 14-9	28
155202001	H - 14-11	28
155203201	H - 14-12	28
155205001	H - 15	28
155262001	P - 23	36
156065001	E - 35-19-4	18
156069001	E - 35-20-4	18
156500001	D - 21	8
156502001	D - 38	8
156505000	C - 12-2	6
156506000	C - 12-2-1	6
156507001	E - 35-18	18
156509001	R - 3-2	40
156511001	R - 67-2	42
156523001	A - 76	4
158740001	D - 38	8
159101000	N - 18	34
159475001	F - 20	20
159476000	A - 63	4
159574101	R - 4-3	40
159636000	D - 20	8
159638001	D - 16	8
159639001	A - 72	4
159640000	A - 68	4
159686001	N - 15-2	34
159884101	M - 13-2	32
180323001	M - 10	32
181031001	J - 1	30
181969003	A - 38	2
	F - 34	20
181995001	Q - 3-6	38
181995002	H - 1-1-18	26
183161201	Z - 56	44
210973001	Z - 29	44
211964001	Z - 68-3	48

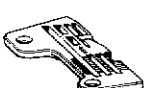



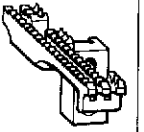
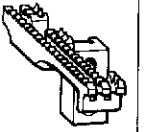

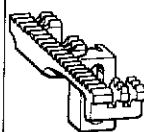
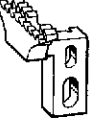
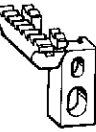
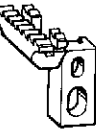
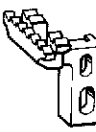
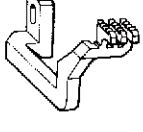
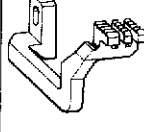
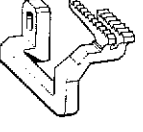
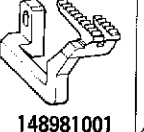
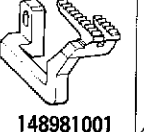
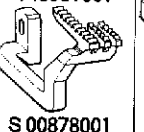
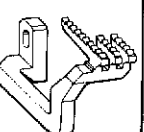



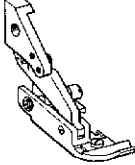
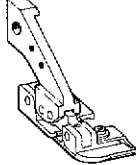
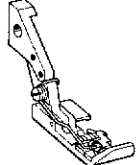
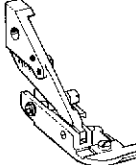
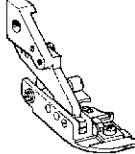
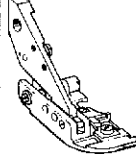

ゲージ部品 / GAUGE PARTS / TEILE DER LEHRE /
PIECES DE JAUGE / PIEZAS DE CALIBRE

サブ クラス Sub-Class	一般地縫用	一般地縫用	一般地縫用	一般地縫用	一般地縫用	一般地縫用	ラフラー用	ラフラー用
	Thin	Thin	Thin medium	Thin medium	Thick	Thick	Ruffling	Ruffling
品名 Name of Parts	061-2 -3 -4 -5	062-3	063-3 -4 -5	064-3 -4 -5	065-5 -6	066-5	067-4 -5 069-5	071-5 -6
オサエクミ Presser Foot Assembly	 142250001	 146871101	 146874101	 146878001 144775001			146881001	
ハリドメクミ Needle Clamp Assembly	 146487001	 146489101	 146491101	 146487001 146489001			 146491001	
ハリイタ Needle Plate	 148280001 146498001 146499001 146500001	 146498001	 146501001 146502001 146503001	 146504001 146505001			 S 01770001 S 01771001 S 01773001 S 01774001 S 01775001	
シュオクリバ Main Feed Dog		 146567001	 146568001	 S 01777001			 S 01778001	
サドウオクリバ Differential Feed Dog		 146572001	 146573001	 146575001			 146576001	
ホジョオクリバ Chain Feed Dog			 146577001				 146578001	

★ 印は、国内向専用部品です。
★ Parts for Japan only.
★ Teile nur für Japan.

★ Pieces pour le Japon.
★ Piezas sólo para el mercado japonés.

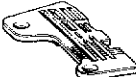
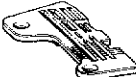
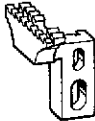
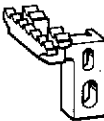
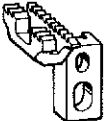
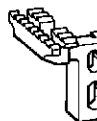
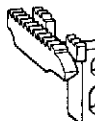
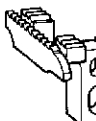
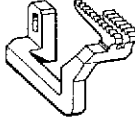
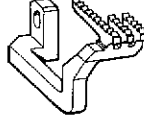
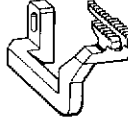
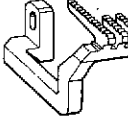
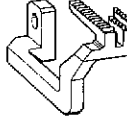
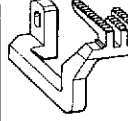
パイピング ラフラー用 Ruffling W/Piping 073-4 074-4	パイピング ラフラー用 Ruffling W/Piping 075-5 076-5	パイピング ラフラー用 Ruffling W/Piping 077-5 -6	テープ用 Taping 079-4	テープ用 Taping 081-3 -4 -5	テープ用 Taping 083-5	テープ用 Taping 084-6	デニム用 Heavy 085-3 -5	デニム用 Heavy 087-5 -6											
 147785001		 147435001		 147437001		 148816001		 147950001		 148705101		 148979101		 148013101 ★146874101					
 146487001		 146489001		 146491001		 146487001		 146489001		 146491001		 146489001		 146491001					
 S 01770001		 S 01773001		 S 01774001		 S 01775001		 146499001		 146501001 146502001 146503001		 146504001		 146505001		 148978001 S 09473001		 147783001 146510001	
 S 01779001		 S 01780001		 S 01776001		 146567001		 146568001		 148980001		 146569001							
 146575001		 146576001		 146572001		 146573001		 148981001		 S 00878001		 146574001							
 146578001								 146577001											

サブ クラス Sub-Class	バイディング用 Binding 089-5	バイディング用 Binding 090-5	デニム用 Heavy 092-5 -6 -7	デニム用 Heavy 093-6	一般地縫用 Thin medium 094-5 -7	一般地縫用 Thin medium 095-5	バルキーニット用 Bulky nit 096-5	バルキーニット用 Bulky nit 097-5
品名 Name of Parts								
オサエクミ Presser Foot Assembly	 147370101		 148013101		 151461001 151462001	 156507001	 S 01762101	 S 01759101
ハリドメクミ Needle Clamp Assembly	 146489001		 146491001		 151467001	 156500001	 S 01957001	 S 01945001
ハリイタ Needle Plate	 147369001		 147783001 146510001 158740001 146510001		 151472001 151473001	 156502001	 S 02863001	 S 02864001
シュオクリバ Main Feed Dog	 146567001		 146569001		 151469001	 146568001	 S 02867001	 S 02868001
サドウオクリバ Differential Feed Dog	 146572001		 146574001		 151470001	 146573001	 S 02865001	 S 02866001
ホジョオクリバ Chain Feed Dog					 146577001			

brother

ブラザー工業株式会社

BROTHER INDUSTRIES, LTD. NAGOYA, JAPAN

185510
195551-701
1988, 10

Printed in Japan/Gedruckt in Japan/Imprimé au Japon/Impreso en Japón