

PARTS BOOK

FOR

BROTHER LK3-B432

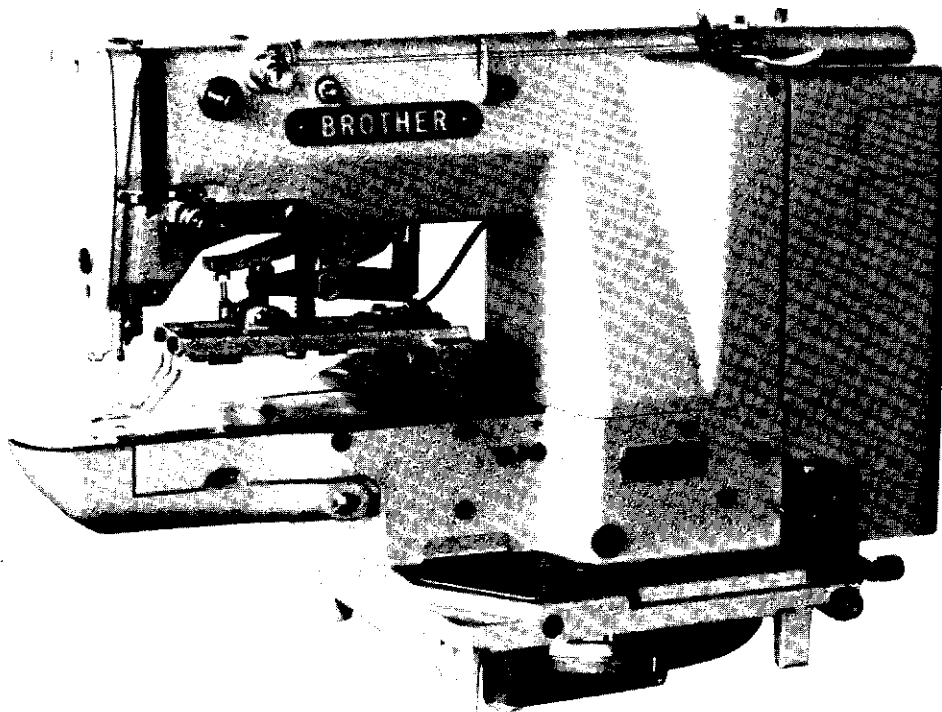

P432002



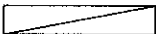

High Speed Lock Stitch Free Arm Type
Eyelet Bar Tacking Sewing Machine

BROTHER INDUSTRIES, LTD.
NAGOYA, JAPAN

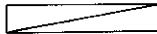

Notes for using this parts book

1. This book is applicable to sewing machines which have the same plate number as shown on the cover of this book (or correction sheet).
2. If the symbol  is found in the "Parts No." column or the "Assembly No." column, refer to the different parts list on page 14.
3. The symbol  in the "Parts No." column indicates that the parts is not available for supply. If, however, there is a number in the "Assembly No." column, the parts can be ordered as an assembly. Please, therefore, order by using the assembly number.
4. Those parts whose "Parts No." columns show  are different according to number of stitches and design.
Therefore, order the parts by using the design number and the part name stamped on the model plate.
5. This book was prepared based on information available in March, 1981.
6. Parts are subject to changes in design without prior notice.

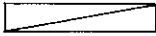

Anmerkungen zum Gebrauch dieses Stücklistebuches

1. Dieses Buch bezieht sich auf die Nähmaschinen mit derselben Kennungsnummer wie auf diesem Buchumschlag (oder auf dem Korrekturblatt).
2. Dieses Zeichen  in der Spalte "Parts No. (Teilnummer)" oder "Assembly No. (Gerätesatznummer)" verweist auf die Gesonderte Stückliste auf Seite 14.
3. Dieses Zeichen  in der Spalte "Teilnummer" bedeutet, daß dieser Teil nicht lieferbar ist. Wenn jedoch in der Spalte "Gerätesatznummer" eine Nummer steht, kann dieser Teil als ein Geräteteilsatz bestellt werden. Bestellen Sie daher bitte mit dieser Gerätesatznummer.
4. Wenn die Kolumne  für die Zubehöre blank ist, unterscheiden sich die Zubehöre in Zahlen der Nadel und Mustern, so daß bitte die Zubehöre nach dem Musternummer und dem Artikel, die beide auf der Namenplate liegen, bestellen.
5. Dieses Buch basiert auf den Informationen vom März, 1981.
6. Modelländerungen sind vorbehalten.

Notes sur l'utilisation de ce manuel de pièces détachées

1. Ce manuel est destiné aux machines à coudre ayant le même numéro de plaque montré sur la couverture de ce manuel (ou sur la feuille de corrections).
2. Si le symbole  se trouve dans la colonne "Parts No. (N° de pièce)" ou dans la colonne "Assembly No. (N° jeu de pces)", veuillez vous référer à la liste de pièces annexe page 14.
3. Le symbole  dans la colonne "N° de pièce" signifie que la pièce ne peut être fournie. Si, dans la colonne "N° jeu de pces", il y a un numéro de nomenclature, la pièce peut être commandée comme faisant partie d'un jeu de pièces. Donc, pour toute commande, veuillez spécifier le n° du jeu de pièces.
4. Le symbole  dans la colonne "N° de pièce" signifie que la pièce peut être commandée par le nom de pièce et la numéro de dessins marquant dans la plaque des données, parce que la pièce-ci est différente par le dessin et le nombre d'aiguille.
5. Ce manuel a été fait d'après les renseignements valables au mois de Mars 1981.
6. Les pièces peuvent être sujettes à des modifications sans préavis.

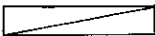
Notas para usar este Libro de Piezas

1. Este libro sirve para todas las máquinas de coser que llevan la misma placa de identificación que la que se puede ver en la tapa de este libro (o en la hoja de erratas).
2. De haber un símbolo  junto al "Parts No. (Número de Pieza)" o en la columna del "Assembly No. (Número de Juego)", habrá que mirar la lista de piezas separada de la página 14.
3. El símbolo  , que se encuentra en la columna del "Número de Pieza", quiere decir que no se dispone de dicha pieza sola. Cuando, empero, hay un número en la columna del "Número de Juego", se podrá ordenar la pieza con todo el juego. Por lo tanto, será mejor hacer el pedido recurriendo al número del juego respectivo.
4. El símbolo  , que se encuentra en la columna del "Número de pieza", quiere decir que esa pieza difiere según el número de puntada y el patrón. Por lo tanto, ordene una pieza con su nombre y el nombre del patrón que se halla en la placa de modelo.
5. Este libro ha sido compilado basándose en los datos de que se disponía en marzo de 1981.
6. Las piezas quedan sujetas a cambios de diseño sin aviso previo.

CONTENTS

A. Machine Body	1
B. Upper Shaft · Lower Shaft and Needle Bar Mechanism	2
C. Pulley and Clutch Mechanism	3
D. Power Lift and Clutch Mechanism	4
E. Presser Arm Mechanism	5
F. Feed Mechanism	6
G. Vertical Shaft Mechanism	7
H. Work Clamp and Thread Wiper Mechanism	8
J. Thread Trimming and Thread Nipper Mechanism	9
K. Bobbin Winder and Threading Mechanism	10
L. Oil Pan	11
M. Lubrication	12
Z. Accessories	13
DIFFERENT PARTS LIST	14
INDEX	15

A. Machine Body

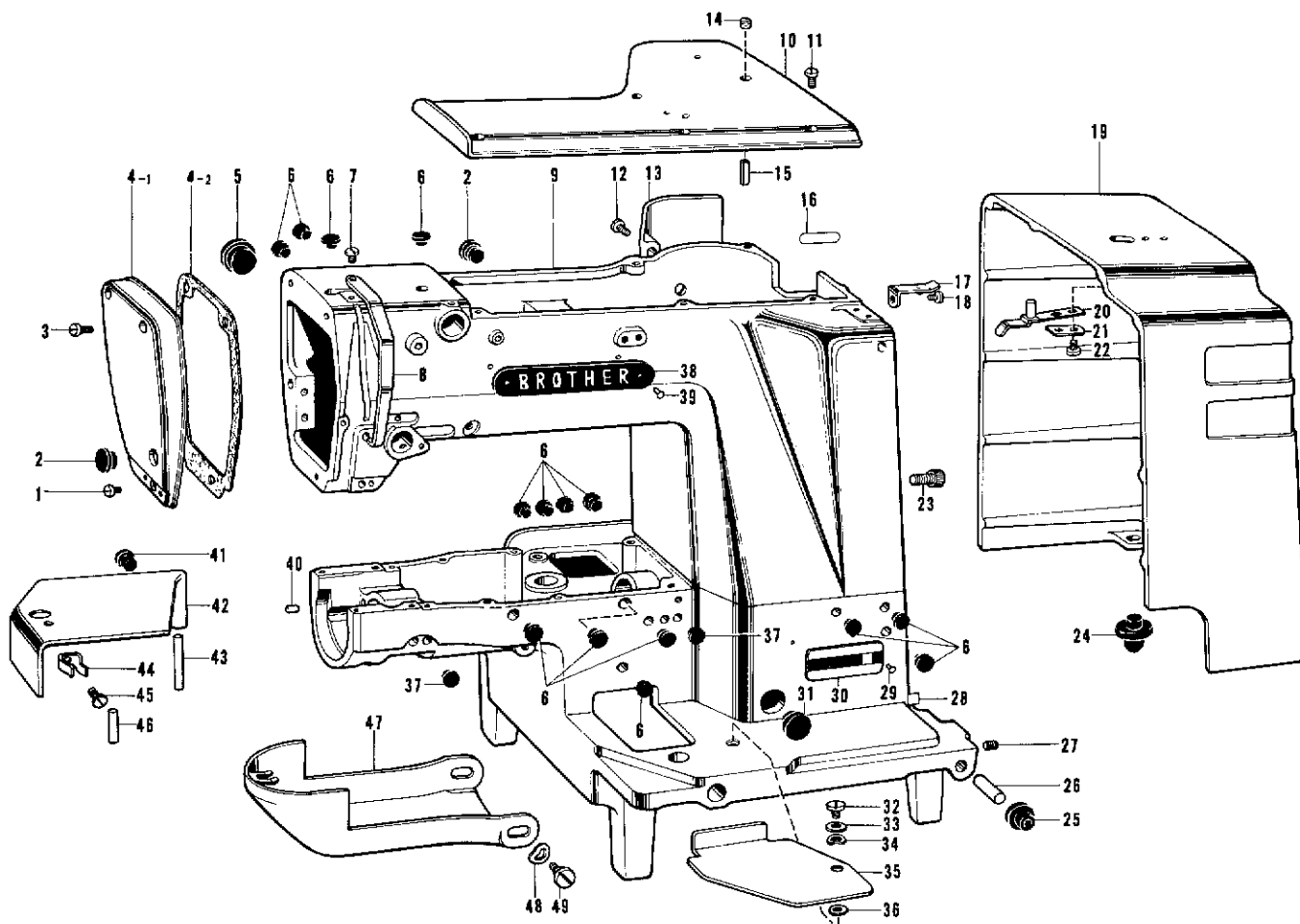

Ref. No.	Name of Parts	Q'ty	Parts No.	Assembly No.	Ref. No.	Name of Parts	Q'ty	Parts No.	Assembly No.
A-1	Screw 4.76 x 7	1	009710-7-12		A-25	Head Cushion	2	152868-0-00	
A-2	Oil Cap	2	117934-0-01		A-26	Hinge Shaft	2	152867-0-00	
A-3	Screw 4.76 x 14	2	009711-4-12		A-27	Screw 5.95	2	151604-0-02	
A-4-1	Face Plate	1	152832-0-02	A-4 Face Plate Assembly 152831-0-00	A-28	Label	1		
A-4-2	Packing	1	152833-0-01		A-29	Pin	2		
A-5	Oil Cap	1	140392-0-01		A-30	Model Plate	1		
A-6	Oil Cap	15	117936-0-01		A-31	Oil Cap	1	108520-0-01	
A-7	Screw 3.57 x 8	1	009670-8-12		A-32	Screw 6.35	1	145480-0-01	
A-8	Thread Take-up Cover	1	152841-0-02		A-33	Washer	1	118719-0-01	
A-9	Arm Bed	1			A-34	Washer	1	100315-0-02	
A-10	Top Cover	1	152830-0-02		A-35	Bed Cover (R)	1	152835-0-02	
A-11	Screw 5.95 x 14	6	009761-4-12		A-36	Washer 6.35	1	025770-2-32	
A-12	Screw 4.76 x 14	4	009711-4-12		A-37	Oil Cap	2	104450-0-01	
A-13	Side Cover (B)	1	155699-0-02		A-38	Name Plate	2		
A-14	Felt	2	154785-0-00		A-39	Pin	4		
A-15	Spring Pin AW5	2	047501-2-42		A-40	Pin	1	141808-0-01	
A-16	Parts Book Number Plate	1			A-41	Oil Cap	1	104450-0-01	
A-17	Belt Cover Spring Plate	1	152989-0-01		A-42	Bed Cover (L) Assembly	1	152836-0-02	
A-18	Screw 4.37 x 8	1	009680-8-12		A-43	Bed Cover Shaft	1	152839-0-01	
A-19	Belt Cover	1	152846-0-02		A-44	Bed Cover Stop Spring	1	114985-0-01	
A-20	Belt Cover Spring	1	152848-0-01		A-45	Screw 4.37 x 6	1	009680-6-12	
A-21	Belt Cover Stopper	1	152986-0-01		A-46	Grooved Pin	1	152838-0-01	
A-22	Screw 4.37 x 8	2	009680-8-12		A-47	Shuttle Race Cover Assembly	1	152842-0-02	
A-24	Packing	2	152847-0-00		A-48	Washer	2	109239-0-02	
					A-49	Screw 5.95	2	115493-0-02	

B. Upper Shaft · Lower Shaft and Needle Bar Mechanism

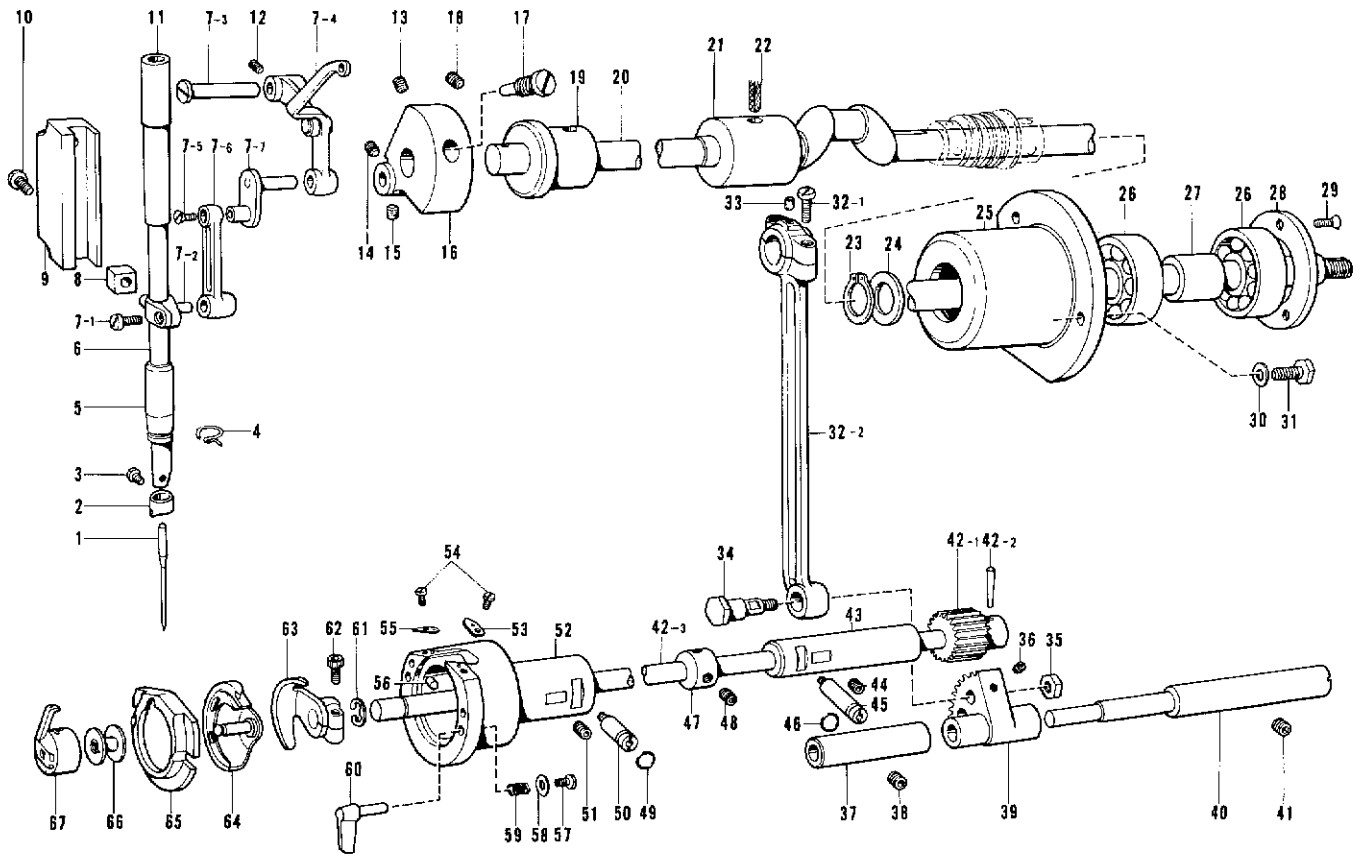

Ref. No.	Name of Parts	Q'ty	Parts No.	Assembly No.	Ref. No.	Name of Parts	Q'ty	Parts No.	Assembly No.
B-1	Needle DP x 5	1	107415-0-14		B-33	Felt	1	107149-0-01	
B-2	Needle Bar Thread Guide (A)	1	152890-0-01		B-34	Screw	1	141786-0-01	
B-3	Screw 3.57	1	144458-0-01		B-35	Nut 7.14	1	104689-0-01	
B-4	Thread Guide (D)	1	152891-0-01		B-36	Screw 4.37 x 6	1	014680-6-22	
B-5	Needle Bar Bushing (D)	1	152243-0-01		B-37	Rock Shaft Bushing	1	152247-0-01	
B-6	Needle Bar (A)	1	152240-0-01		B-38	Screw 5.95 x 6	1	014760-6-22	
B-7-1	Screw 4.37 x 8	1	009680-8-12		B-39	Rock Gear	1	152245-0-01	
B-7-2	Needle Bar Clamp	1	152239-0-01		B-40	Rock Gear Shaft	1	152246-0-01	
B-7-3	Stud	1	152236-0-01		B-41	Screw 5.95 x 6	1	014760-6-22	
B-7-4	Thread Take-up Assembly	1	153330-0-01	B-7 Thread Take-up Lever Assembly 152232-0-01	B-42-1	Lower Shaft Gear	1		B-42 Lower Shaft Assembly 152191-0-01
B-7-5	Screw 3.57L	1	100253-0-01		B-42-2	Taper Pin 3 x 16	1	046301-6-20	
B-7-6	Needle Bar Connector	1	152238-0-01		B-42-3	Lower Shaft	1		
B-7-7	Needle Bar Crank	1	152237-0-01		B-43	Lower Shaft Bushing	1	152250-0-01	
B-8	Slide Block	1	142211-0-01		B-44	Screw 5.95 x 6	1	014760-6-22	
B-9	Needle Bar Guide	1	152244-0-00		B-45	Driver Adjusting Stud	1	152676-0-01	
B-10	Screw 6.35 x 14	2	009781-4-12		B-46	Packing PW3	1	081003-6-70	
B-11	Needle Bar Bushing (U)	1	152242-0-01		B-47	Collar	1	110495-0-03	
B-12	Screw 5.95	1	013761-4-12		B-48	Screw 6.35 x 6	2	014770-6-22	
B-13	Screw 6.35 x 6	1	014770-6-22		B-49	Packing PW3	1	081003-6-70	
B-14	Screw 6.35 x 6	1	014770-6-22		B-50	Shuttle Hook Adjusting Stud	1	152678-0-01	
B-15	Screw 6.35	1	101706-0-01		B-51	Screw 5.95 x 6	1	014760-6-22	
B-16	Counter Weight	1	152231-0-00		B-52	Shuttle Race Body	1	152677-0-01	
B-17	Screw 7.14	1	100250-0-01		B-53	Shuttle Race Thread Guide (R)	1	152679-0-01	
B-18	Screw 5.95	1	013761-4-12		B-54	Screw 3.18 x 3	2	009660-3-12	
B-19	Upper Shaft Bushing (Front)	1	152000-0-01		B-55	Shuttle Race Thread Guide (L)	1	152680-0-01	
B-20	Upper Shaft	1	151995-0-01		B-56	Felt	2	153050-0-00	
B-21	Upper Shaft Bushing (Intermediate)	1	140726-0-00		B-57	Screw 3.18 x 7	2	009660-7-12	
B-22	Wick 4 x 4	1	153925-0-01		B-58	Washer 3.2	2	402887-0-01	
B-23	Stop Ring C15	1	048150-1-42		B-59	Spring	2	152684-0-01	
B-24	Thrust Ring	1	116920-0-01		B-60	Shuttle Race Ring Set Claw	2	152683-0-01	
B-25	Ball Bearing Case	1	151997-0-00		B-61	Stop Ring E8	1	048080-3-42	
B-26	Ball Bearing 6302VV	2	072630-2-60		B-62	Bolt 5 x 14	1	018501-4-22	
B-27	Bearing Collar	1	151998-0-00		B-63	Driver	1	152681-1-01	
B-28	Bearing Cap	1	151999-0-01		B-64	Shuttle Hook (A)	1	152685-0-01	
B-29	Screw 3.57	3	102843-0-04		B-65	Shuttle Race Ring (A)	1	152682-0-01	
B-30	Washer 6	3	025060-2-32		B-66	Bobbin	1	145265-0-01	
B-31	Bolt 5.95 x 14	3	017761-4-12		B-67	Bobbin Case Assembly (A)	1	152688-1-01	
B-32-1	Screw 4.76	2	144712-0-02						
B-32-2	Crank Rod	1		B-32 Crank Rod Assembly 153040-0-01					

C. Pulley and Clutch Mechanism

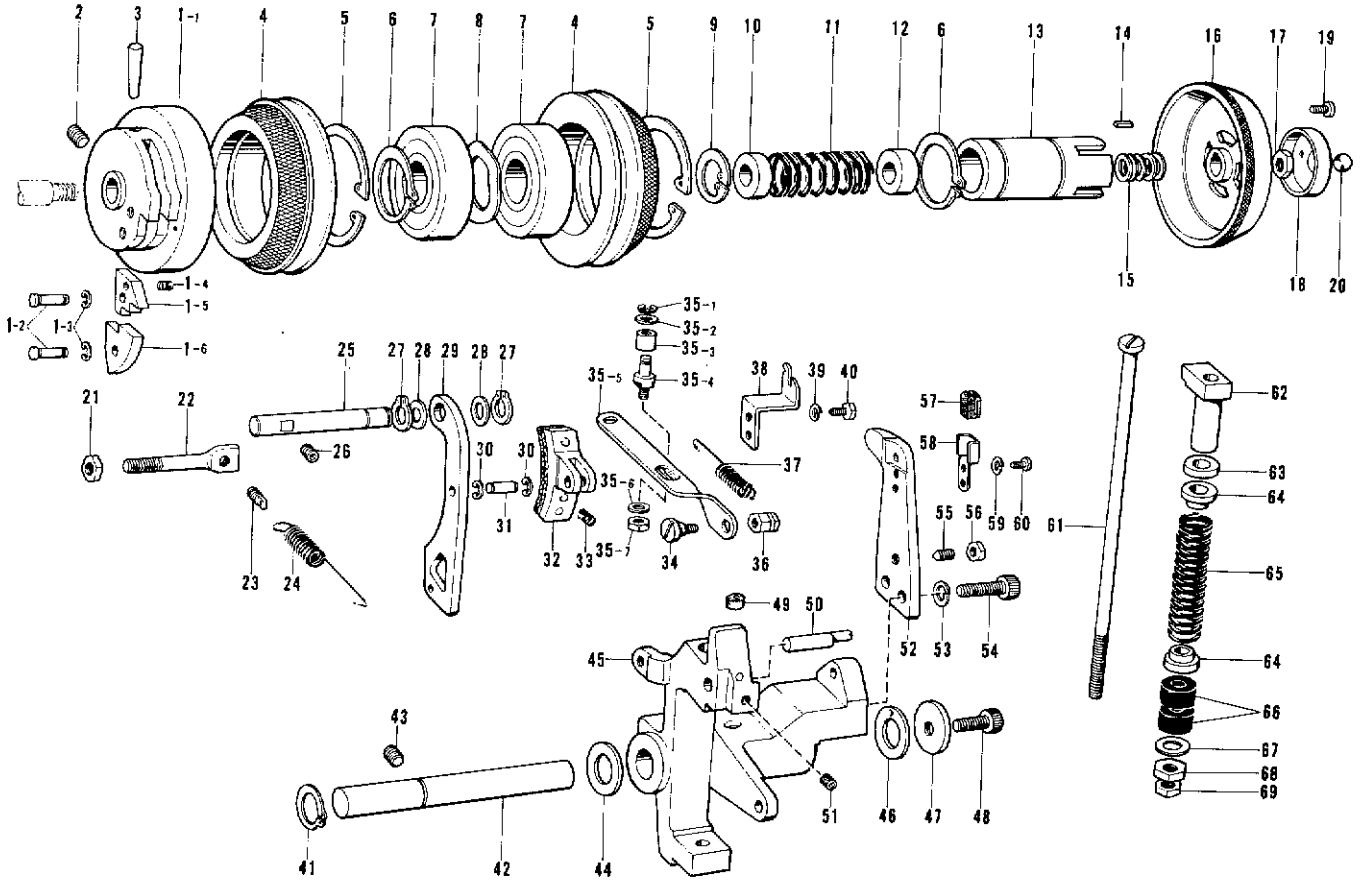

Ref. No.	Name of Parts	Q'ty	Parts No.	Assembly No.	Ref. No.	Name of Parts	Q'ty	Parts No.	Assembly No.
C- 1-1	Stop Cam Assembly	1		C-1 Stop Cam Assembly 153044-0-01	C-35-2	Washer	1	113431-0-02	C-35 Clutch Lever Rod Assembly 151904-1-01
C- 1-2	Pin	2	153058-0-01		C-35-3	Roller	1	107744-0-01	
C- 1-3	Stop Ring E4	2	048040-3-42		C-35-4	Roller Stud	1	151906-1-01	
C- 1-4	Brake Cam Segment Spring	1	152694-0-01		C-35-5	Clutch Lever Rod	1	151905-1-01	
C- 1-5	Brake Cam Segment	1	152693-0-01		C-35-6	Washer 4.37	1	025680-1-33	
C- 1-6	Flange Cam Segment	1	115003-0-01		C-35-7	Nut 4.37	1	021680-2-02	
C- 2	Screw 6.35 x 6	1	014770-6-22	C-36	Nut 5.95	1	151908-0-01		
C- 3	Taper Pin 6 x 35	1	147111-0-01	C-37	Spring	1	155501-0-01		
C- 4	Pulley Assembly	2	152695-0-01	C-38	Spring Hook	1	151910-0-01		
C- 5	Stop Ring C62	2	048620-2-42	C-39	Washer 2-5	2	028050-2-42		
C- 6	Stop Ring C35	2	048350-1-42	C-40	Bolt 4.76 x 14	2	017711-4-12		
C- 7	Ball Bearing 6007VV	2	072600-7-60	C-41	Stop Ring C18	1	048180-1-42		
C- 8	Washer	1	152699-0-01	C-42	Clutch Lever Shaft	1	151887-0-01		
C- 9	Stop Ring C24	1	048240-2-42	C-43	Screw 7.94 x 10	1	014821-0-22		
C-10	Slide Bush (B)	1	151946-0-00	C-44	Washer 18	1	152756-0-01		
C-11	Clutch Spring	1	152701-0-01	C-45	Clutch Lever	1	151886-0-01		
C-12	Slide Bush (A)	1	152700-0-00	C-46	Washer 18	1	151929-0-00		
C-13	Slide Metal	1	152698-0-01	C-47	Washer 8	1	152728-0-01		
C-14	Key 3 x 3 x 6	1	152704-0-00	C-48	Bolt 8 x 15	1	151163-0-01		
C-15	Spacer	5	152703-0-00	C-49	Felt	1	151927-0-01		
C-16	Clutch	1	152702-0-01	C-50	Brake Side Pin	1	151901-0-01		
C-17	Nut 10L	1	152705-0-01	C-51	Screw 5.95 x 6	1	014760-6-22		
C-18	Ball Holder	1	152706-0-01	C-52	Ball Presser Plate	1	151888-1-01		
C-19	Screw 3.18 x 7	4	009660-7-12	C-53	Washer 2-8	2	028080-2-42		
C-20	Steel Ball 3/8	1	071095-2-50	C-54	Bolt 8 x 25	2	018082-5-22		
C-21	Nut 7.94	1	106147-0-01	C-55	Screw 6.35	1	115012-0-02		
C-22	Spring Hook	1	151903-0-01	C-56	Nut 6.35	1	150554-0-02		
C-23	Spring Hook	1	110251-0-01	C-57	Wick	1	152977-0-01		
C-24	Brake Spring	1	151902-0-01	C-58	Wick Holder	1	152976-0-01		
C-25	Brake Lever Shaft	1	151900-0-01	C-59	Washer 2-4	2	028040-2-42		
C-26	Screw 5.95	1	013761-4-10	C-60	Screw 3.57 x 5	2	009670-5-12		
C-27	Stop Ring C11	2	048110-1-42	C-61	Stopper Bar	1	151893-0-01		
C-28	Horizontal Feed Crank Ring	2	142628-0-01	C-62	Clutch Stopper	1	151889-0-01		
C-29	Brake Lever	1	151894-0-01	C-63	Cushion Rubber	1	151890-0-00		
C-30	Stop Ring E4	2	048040-3-42	C-64	Spring Holder	2	151892-0-01		
C-31	Brake Shaft	1	151898-0-01	C-65	Clutch Spring	1	151891-0-01		
C-32	Brake Assembly	1	151895-0-00	C-66	Cushion Rubber	2	115018-0-01		
C-33	Spring	1	151899-0-01	C-67	Washer 7.14	1	025800-3-33		
C-34	Screw 5.95	1	151907-0-01	C-68	Nut 7.14	1	021800-1-03		
C-35-1	Stop Ring E3	1	048030-3-42	C-35 151904-1-01	C-69	Nut 7.14	1	104689-0-01	

D. Power Lift and Clutch Mechanism

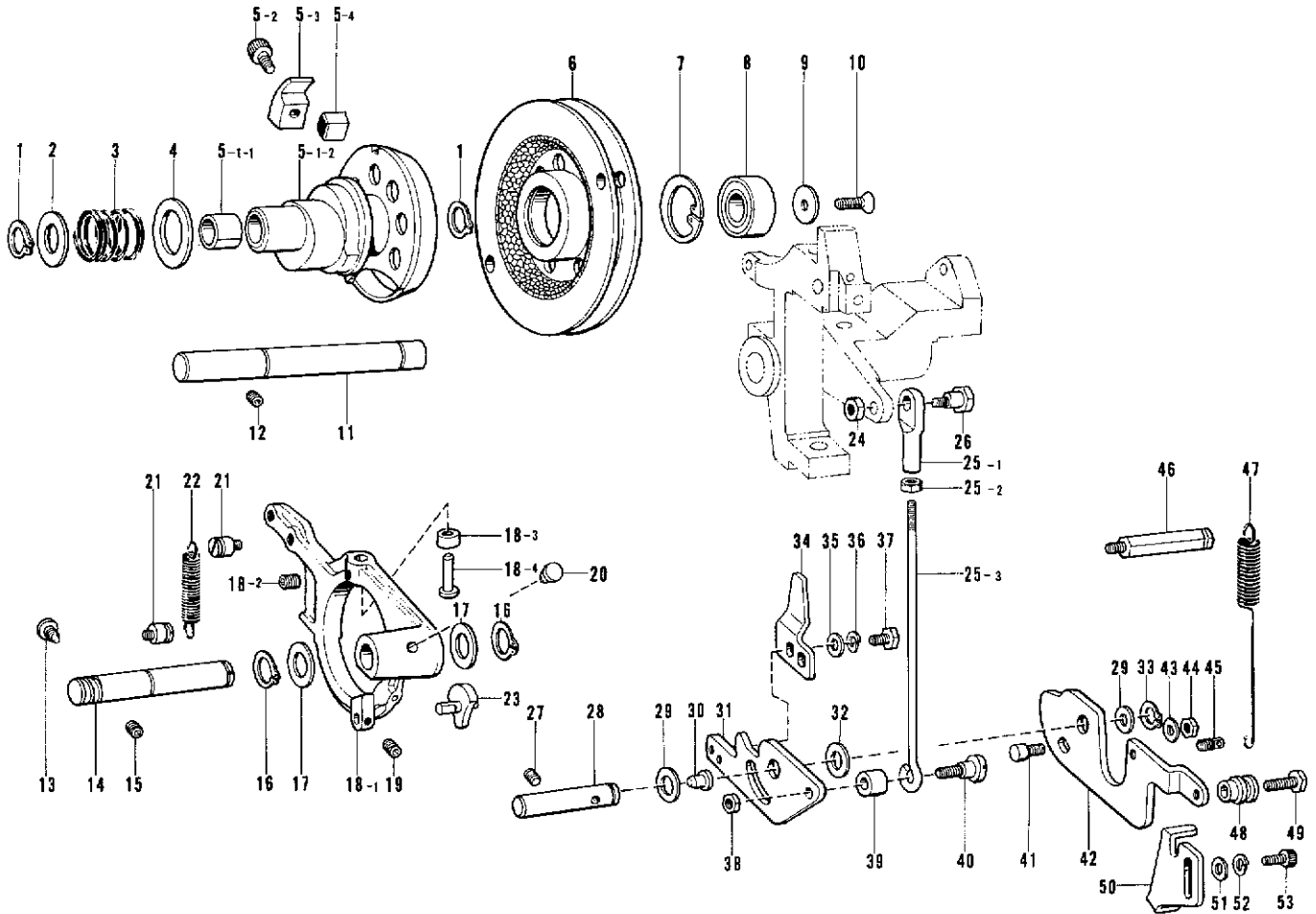

Ref. No.	Name of Parts	Q'ty	Parts No.	Assembly No.	Ref. No.	Name of Parts	Q'ty	Parts No.	Assembly No.
D- 1	Stop Ring C17	2	048170-1-42		D-25-1	Joint	1	154333-0-01	D-25 Connecting Rod Assembly 152808-1-01
D- 2	Washer 17	1	151937-0-01		D-25-2	Nut 6.35	1	150555-0-01	
D- 3	Clutch Spring P	1	151936-0-01		D-25-3	Connecting Rod	1	154332-0-01	
D- 4	Washer	1	151938-0-01		D-26	Screw 6.35	1	151912-0-01	
D- 5-1-1	DV Bush	2	151935-0-00	D-5-1 Power Cam Assembly 151933-0-01	D-27	Screw 5.95	1	013761-4-10	
D- 5-1-2	Power Cam	1			D-28	Starting Lever Shaft	1	151925-0-01	
D- 5-2	Bolt 6 x 8	1	018060-8-22	D-5 Power Cam Set 155523-0-01	D-29	Horizontal Feed Crank Ring	2	142628-0-01	
D- 5-3	Power Cam Stopper (A)	1	151940-0-01		D-30	Cap for Oil Inlet	1	111865-0-01	
D- 5-4	Power Cam Stopper (B) Assembly	1	151941-0-01		D-31	Starting Lever	1	151919-1-01	
D- 6	Pulley	1	153867-1-01		D-32	Washer	1	110505-0-01	
D- 7	Stop Ring C35	1	048350-2-42		D-33	Stop Ring C11	1	048110-1-42	
D- 8	Ball Bearing 6003VV	1	072600-3-60		D-34	Starting Safety Lever	1	151920-0-01	
D- 9	Bearing Cover	1	151932-0-01		D-35	Washer	2	113431-0-02	
D-10	Screw 4.76	1	107231-0-02		D-36	Washer 2-5	2	028050-2-42	
D-11	P Pulley Shaft	1	151928-0-01		D-37	Bolt 4.76 x 14	2	017711-4-12	
D-12	Screw 5.95 x 6	1	014760-6-22		D-38	Nut 6.35	1	150556-0-01	
D-13	Screw	1	151954-0-01		D-39	Collar 13	1	151914-0-01	
D-14	Clutch Actuating Lever Shaft	1	151952-0-01		D-40	Screw 6.35	1	151913-0-01	
D-15	Screw 7.94 x 10	1	014821-0-22		D-41	Screw	1	154155-1-01	
D-16	Stop Ring C16	2	048160-1-42		D-42	Starting Lever Plate	1	155499-0-01	
D-17	Washer 16	2	151953-0-01		D-43	Washer 6	1	025060-2-32	
D-18-1	Clutch Actuating Lever	1		D-18 Clutch Actuating Lever Assembly 151944-0-01	D-44	Nut 5.95	1	150553-0-01	
D-18-2	Screw 5.95 x 6	2	014760-6-22		D-45	Spring Hook	1	110251-0-01	
D-18-3	Roller 11	2	151947-1-01		D-46	Spring Hook	1	151924-0-01	
D-18-4	Roller Stud	2	151948-0-01		D-47	Spring	1	151923-0-01	
D-19	Screw 5.95 x 6	1	014760-6-22		D-48	Chain Hook	1	151922-0-01	
D-20	Cap for Oil Inlet	1	111865-0-01		D-49	Bolt 5.95 x 22	1	017762-2-02	
D-21	Spring Hook	2	141472-0-02		D-50	Starting Lever Stopper	1	155500-0-01	
D-22	Spring	1	151951-0-01		D-51	Washer	2	025060-1-32	
D-23	Roller Stud Assembly	1	151949-0-01		D-52	Washer 2-6	2	028060-2-42	
D-24	Nut 6.35	1	150556-0-01		D-53	Bolt 6 x 16	2	018061-6-22	

E. Presser Arm Mechanism

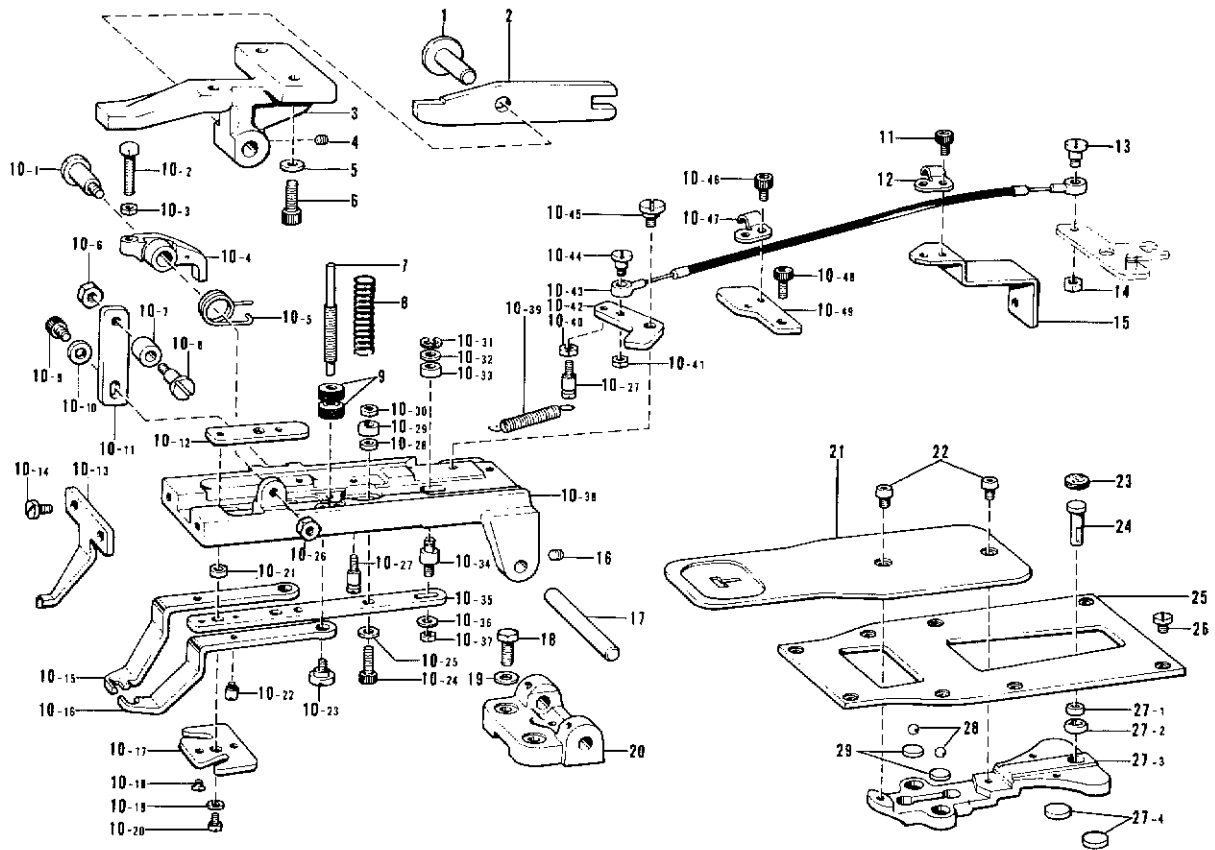

Ref. No.	Name of Parts	Q'ty	Parts No.	Assembly No.	Ref. No.	Name of Parts	Q'ty	Parts No.	Assembly No.
E- 1	Button Clamp Lever Shaft	1	153838-0-01		E-10-32	Washer 4.76	1	025710-1-32	E-10 Presser Arm Assembly 155698-0-01
E- 2	Presser Arm Lifting Lever	1	155565-0-01		E-10-33	Roller	1	155576-0-01	
E- 3	Bracket	1	155564-0-01		E-10-34	Screw 4.76	1	155577-0-01	
E- 4	Screw 5.95 x 6	1	014760-6-22		E-10-35	Work Clamp Carrier Plate	1	155562-0-01	
E- 5	Washer 6	2	025060-2-32		E-10-36	Washer 4.76	1	025710-2-32	
E- 6	Bolt 6 x 20	2	018062-0-22		E-10-37	Nut 4.76	1	021710-2-12	
E- 7	Screw	1	155567-0-01		E-10-38	Presser Fram	1	155561-0-01	
E- 8	Spring	1	115147-0-01		E-10-39	Spring	1	156061-0-01	
E- 9	Tension Control Nut	2	146994-0-01		E-10-40	Nut 4.37	1	021680-2-02	
E-10- 1	Screw 5.95	1	118257-0-01	E-10 Presser Arm Assembly 155698-0-01	E-10-41	Nut 4.37	1	021680-2-02	
E-10- 2	Bolt 4.37	1	118259-0-01		E-10-42	Work Clamp Lever	1	155575-0-01	
E-10- 3	Nut 4.37	1	021680-3-03		E-10-43	Flexible Wire Assembly	1	155570-0-01	
E-10- 4	Stop Lever	1	118256-0-01		E-10-44	Screw 4.37	1	148417-0-01	
E-10- 5	Stop Lever Spring	1	118258-0-01		E-10-45	Screw 5.95	1	118244-0-01	
E-10- 6	Nut 4.76	1	021710-2-12		E-10-46	Bolt 5 x 8	1	018500-8-22	
E-10- 7	Roller	1	152914-0-01		E-10-47	Wire Holder	1	153941-0-01	
E-10- 8	Screw 4.76	1	155569-0-01		E-10-48	Bolt M5 x 12	1	018501-2-22	
E-10- 9	Bolt 6 x 10	1	018061-0-22		E-10-49	Wire Holder (A)	1	155573-0-01	
E-10-10	Washer 6	1	025060-2-32		E-11	Bolt 4.37 x 10	1	018681-0-22	
E-10-11	Work Clamp Lifting Plate	1	155568-0-01		E-12	Wire Holder	1	153941-0-01	
E-10-12	Stop Position Adjusting Plate	1	118248-0-01		E-13	Screw 4.37	1	148417-0-01	
E-10-13	Button Hole Guide	1	118253-0-01		E-14	Nut 4.37	1	021680-2-02	
E-10-14	Screw 5.95 x 10	2	009761-0-12		E-15	Wire Holder (B)	1	155524-0-01	
E-10-15	Work Clamp (L)	1	118250-0-01		E-16	Screw 4.37 x 6	2	014680-6-22	
E-10-16	Work Clamp (R)	1	118249-0-01		E-17	Button Clamp Holder Shaft	1	153827-0-01	
E-10-17	Work Clamp Guide Plate	1	118251-0-01		E-18	Bolt 5.95 x 14	2	017761-4-12	
E-10-18	Screw 4.37	2	117143-0-01		E-19	Washer 6	2	025060-2-32	
E-10-19	Washer 4.76	2	025710-1-32		E-20	Button Clamp Holder Bracket	1	153834-0-01	
E-10-20	Screw 4.37 x 10	2	009681-0-12		E-21	Feed Plate	1	155563-0-01	
E-10-21	Collar	2	118247-0-01		E-22	Screw	2	153057-0-01	
E-10-22	Screw	2	118252-0-01		E-23	Felt	1	153035-0-00	
E-10-23	Screw 5.95	2	118244-0-01		E-24	Tack Width Shaft	1	152759-0-01	
E-10-24	Bolt 4 x 16	1	018401-6-22		E-25	Feed Guide Plate	1	152766-0-01	
E-10-25	Washer 4.76	1	025710-2-32		E-26	Screw 4.37	8	145318-0-01	
E-10-26	Nut 5.95	1	150553-0-02		E-27- 1	Bushing	1	141331-0-01	
E-10-27	Spring Hook	2	156161-0-01		E-27- 2	Bushing	1	152773-0-00	
E-10-28	Collar	1	118247-0-01		E-27- 3	Feed Guide	1	152773-0-00	
E-10-29	Collar	1	156170-0-01		E-27- 4	Washer	2	152771-0-00	
E-10-30	Nut 4	1	021400-1-03		E-28	Steel Ball 3/16	2	071047-6-50	
E-10-31	Stop Ring E4	1	048040-3-42		E-29	Washer	2	152772-0-01	

F. Feed Mechanism

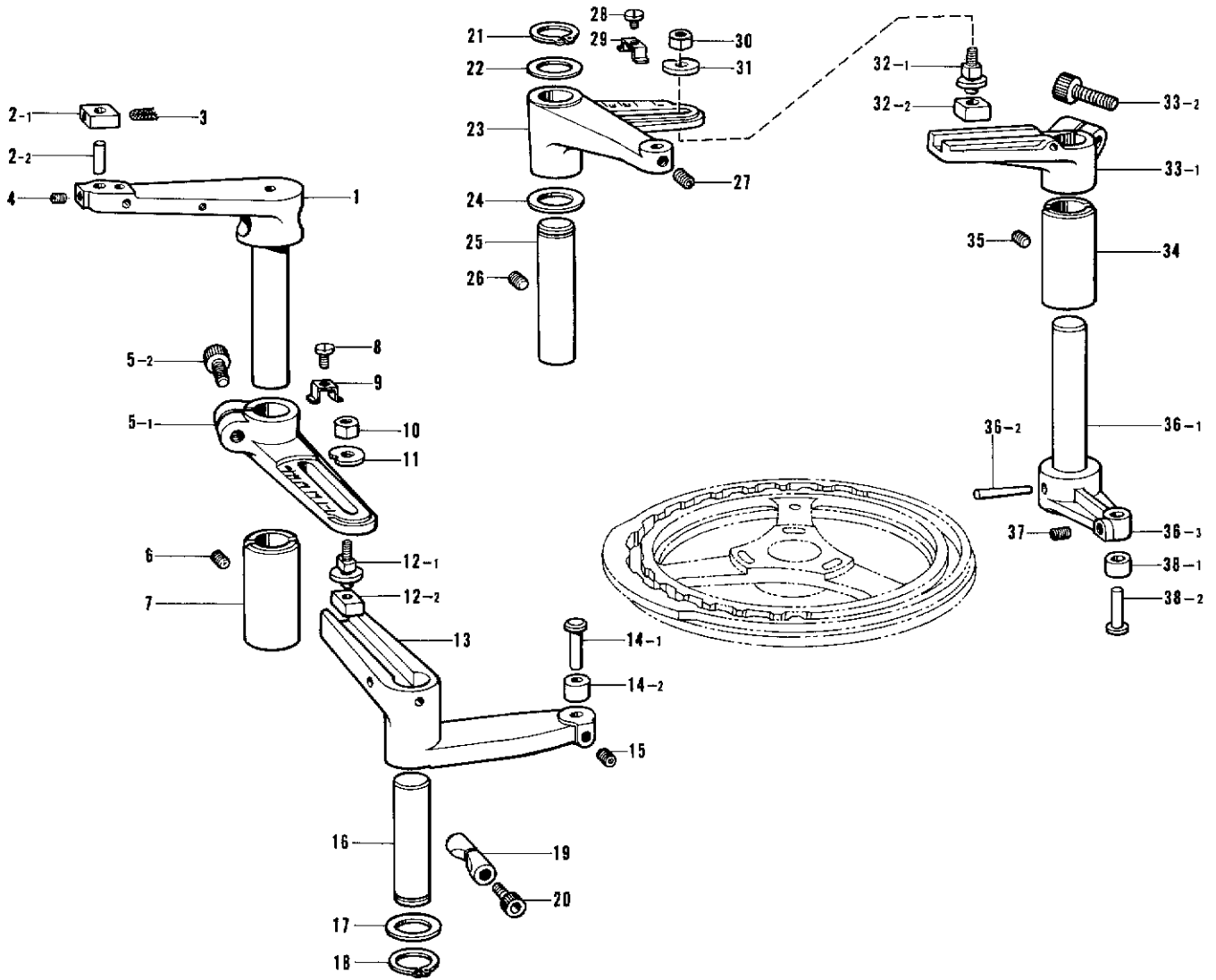

Ref. No.	Name of Parts	Q'ty	Parts No.	Assembly No.	Ref. No.	Name of Parts	Q'ty	Parts No.	Assembly No.
F- 1	Tack Length Lever	1	152742-0-01		F-20	Bolt 6 x 30	1	018063-0-22	
F- 2-1	Tack Length Slide Block	1		F-2 Tack Length Slide Block Assembly 153041-0-01	F-21	Stop Ring C18	1	048180-1-42	
F- 2-2	Tack Length Slide Block Pin	1			F-22	Washer 18	1	152756-0-01	
F- 3	Wick	1	153926-0-01		F-23	Tack Width Lever	1	152758-0-01	
F- 4	Screw 4.37	1	151602-0-02		F-24	Washer 18	1	152756-0-01	
F- 5-1	Tack Length Regulator Lever	1		F-5 Tack Length Regulator Lever Assembly 153762-1-01	F-25	Tack Width Lever Shaft	1	152760-0-01	
F- 5-2	Bolt 8 x 20	1	018082-0-22		F-26	Screw 5.95 x 6	1	014760-6-22	
F- 6	Screw 5.95 x 6	1	014760-6-22		F-27	Screw 5.95 x 6	1	014760-6-22	
F- 7	Bushing	1	152745-0-01		F-28	Screw 3.57	1	105451-0-02	
F- 8	Screw 3.57	1	105451-0-02		F-29	Tack Length Lever Stopper	1	153045-0-01	
F- 9	Tack Length Lever Stopper	1	153045-0-01		F-30	Nut	1	152750-0-01	
F-10	Nut	1	152750-0-01		F-31	Washer	1	152749-0-01	
F-11	Washer	1	152749-0-01		F-32-1	Tack Regulator Shaft	1		F-32 Tack Regulator Shaft Assembly 153042-0-01
F-12-1	Tack Regulator Shaft	1		F-12 Tack Regulator Shaft Assembly 153042-0-01	F-32-2	Slide Block	1		
F-12-2	Slide Block	1			F-33-1	Tack Width Regulator Lever	1		F-33 Tack Width Regulator Lever Assembly 153757-0-01
F-13	Tack Length Lever	1	152752-0-01		F-33-2	Bolt 8 x 20	1	018082-0-22	
F-14-1	Roller Stud	1		F-14 Roller Stud Assembly 153043-0-01	F-34	Bushing	1	152745-0-01	
F-14-2	Roller	1			F-35	Screw 5.95 x 6	1	014760-6-22	
F-15	Screw 5.95 x 6	1	014760-6-22		F-36-1	Tack Width Feed Shaft	1		F-36 Tack Width Feed Shaft Assembly 153331-0-01
F-16	Tack Length Lever Shaft	1	152755-0-01		F-36-2	Taper Pin 4 x 32	1	152738-0-01	
F-17	Washer 18	1	152756-0-01		F-36-3	Tack Width Feed Lever	1		
F-18	Stop Ring C18	1	048180-1-42		F-37	Screw 5.95 x 6	1	014760-6-22	
F-19	Sleeve	1	152725-0-00		F-38-1	Roller	1		F-38 Roller Stud Assembly 153043-0-01
					F-38-2	Roller Stud	1		

G. Vertical Shaft Mechanism

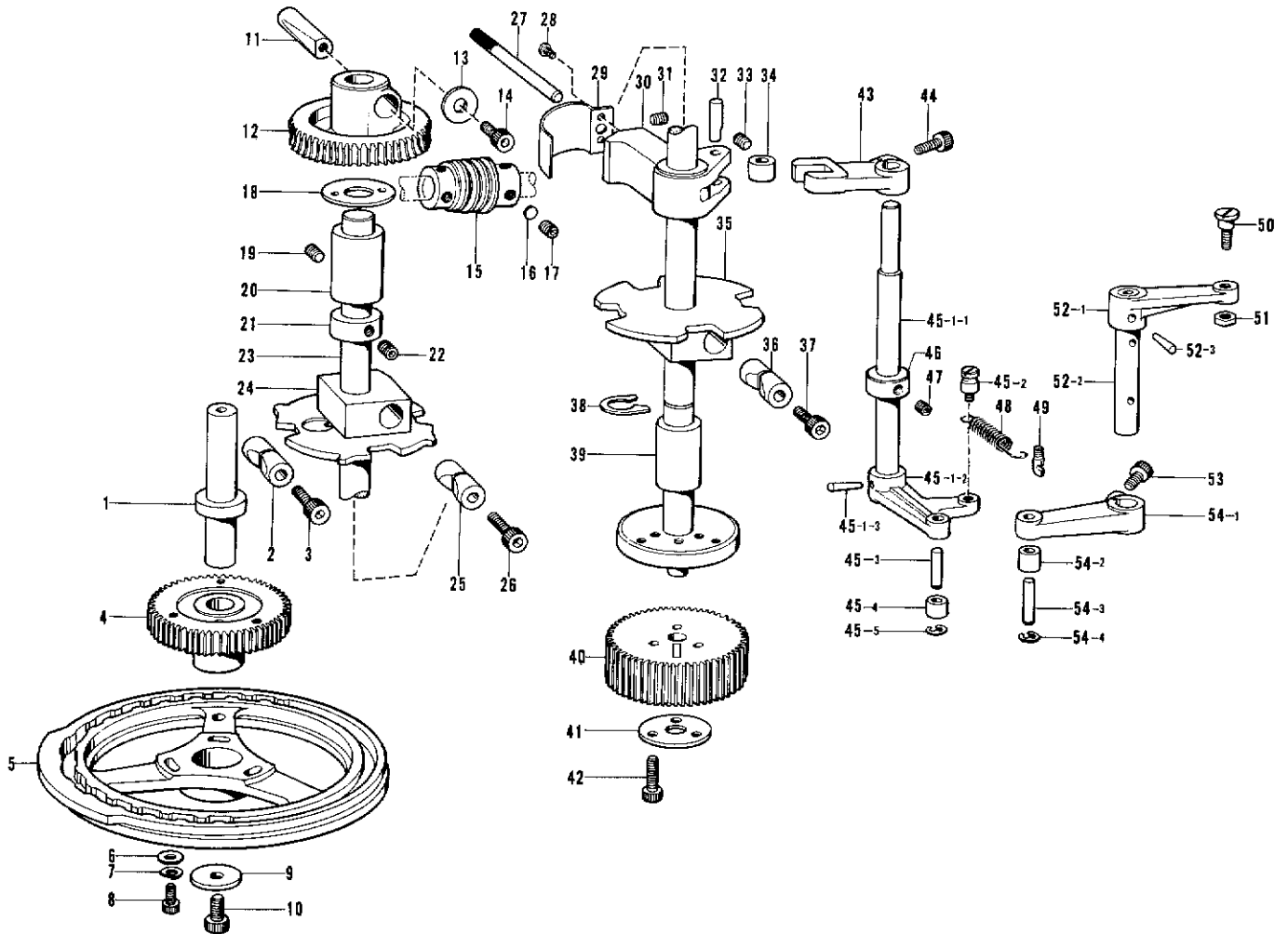

Ref. No.	Name of Parts	Q'ty	Parts No.	Assembly No.	Ref. No.	Name of Parts	Q'ty	Parts No.	Assembly No.
G-1	Tack Length Feed Cam Shaft	1	152724-0-01		G-34	Roller	1	152914-0-01	
G-2	Sleeve	1	152725-0-00		G-35	Knife Cam	1	152730-0-01	
G-3	Bolt 6 x 30	1	018063-0-22		G-36	Sleeve	1	152725-0-00	
G-4	Change Gear (C)	1			G-37	Bolt 6 x 30	1	018063-0-22	
G-5	Feed Cam	1			G-38	Stop Ring	1	152723-0-01	
G-6	Washer	3	109893-0-02		G-39	Vertical Shaft Bushing (D)	1	152712-0-01	
G-7	Washer 2-6	3	028060-2-42		G-40	Change Gear (W)	1		
G-8	Bolt 6 x 20	3	018062-0-22		G-41	Washer	1	153104-0-01	
G-9	Washer 8	1	152728-0-01		G-42	Bolt 6 x 22	3	018062-2-22	
G-10	Bolt 8 x 15	1	151163-0-01		G-43	Roller Holder Lever	1	152734-0-01	
G-11	Sleeve	1	152709-0-00		G-44	Bolt 6 x 16	1	018061-6-22	
G-12	Worm Wheel	1	152708-0-00		G-45-1-1	Roller Holder Lever Shaft	1		G-45-1 Roller Holder Lever Shaft Assembly 153332-0-01
G-13	Washer	1	152710-0-01		G-45-1-2	Roller Holder Cam Lever	1		
G-14	Bolt 6 x 20	1	018062-0-22		G-45-1-3	Taper Pin 3 x 20	1	046302-0-20	
G-15	Worm	1	152707-0-01		G-45-2	Spring Hook	1	155337-0-01	G-45
G-16	Washer	1	147151-0-00		G-45-3	Pin	1	152739-0-01	Roller Holder Cam Lever Assembly
G-17	Screw 5.95	6	152718-0-01		G-45-4	Roller	1	153195-0-01	152735-1-01
G-18	Washer	1	152713-0-01		G-45-5	Stop Ring E4	1	048040-3-42	
G-19	Screw 5.95 x 6	1	014760-6-22		G-46	Collar	1	110027-0-01	
G-20	Vertical Shaft Bushing (U)	1	152711-0-00		G-47	Screw 5.95 x 6	2	014760-6-22	
G-21	Coller	1	141816-0-01		G-48	Spring	1	153336-0-01	
G-22	Screw 6.35 x 6	2	014770-6-22		G-49	Spring Hook	1	141334-0-01	
G-23	Vertical Shaft Assembly	1	152715-0-01		G-50	Screw 5.95	1	151907-0-01	
G-24	Clutch Cam	1	152729-0-01		G-51	Nut 5.95	1	150553-0-01	
G-25	Sleeve	1	152725-0-00		G-52-1	Clutch Actuating Lever	1		G-52 Clutch Actuating Lever Assembly 151915-0-01
G-26	Bolt 6 x 30	1	018063-0-22		G-52-2	Clutch Actuating Lever Shaft	1		
G-27	Emergency Stop Lever	1	152733-0-01		G-52-3	Taper Pin	1	107030-0-01	
G-28	Screw 3.57 x 4	2	009670-4-12		G-53	Bolt 6 x 20	1	018062-0-22	
G-29	Cover	1	153141-0-01		G-54-1	Clutch Cam Lever	1		G-54 Clutch Cam Lever Assembly 151939-0-01
G-30	Roller Holder	1	152731-0-01		G-54-2	Roller	1	152914-0-01	
G-31	Screw 4.76	1	013710-7-12		G-54-3	Roller Stud	1	152913-0-01	
G-32	Pin	1	152732-0-01		G-54-4	Stop Ring E4	1	048040-3-42	
G-33	Screw 4.76	1	013710-7-12						

H. Work Clamp and Thread Wiper Mechanism

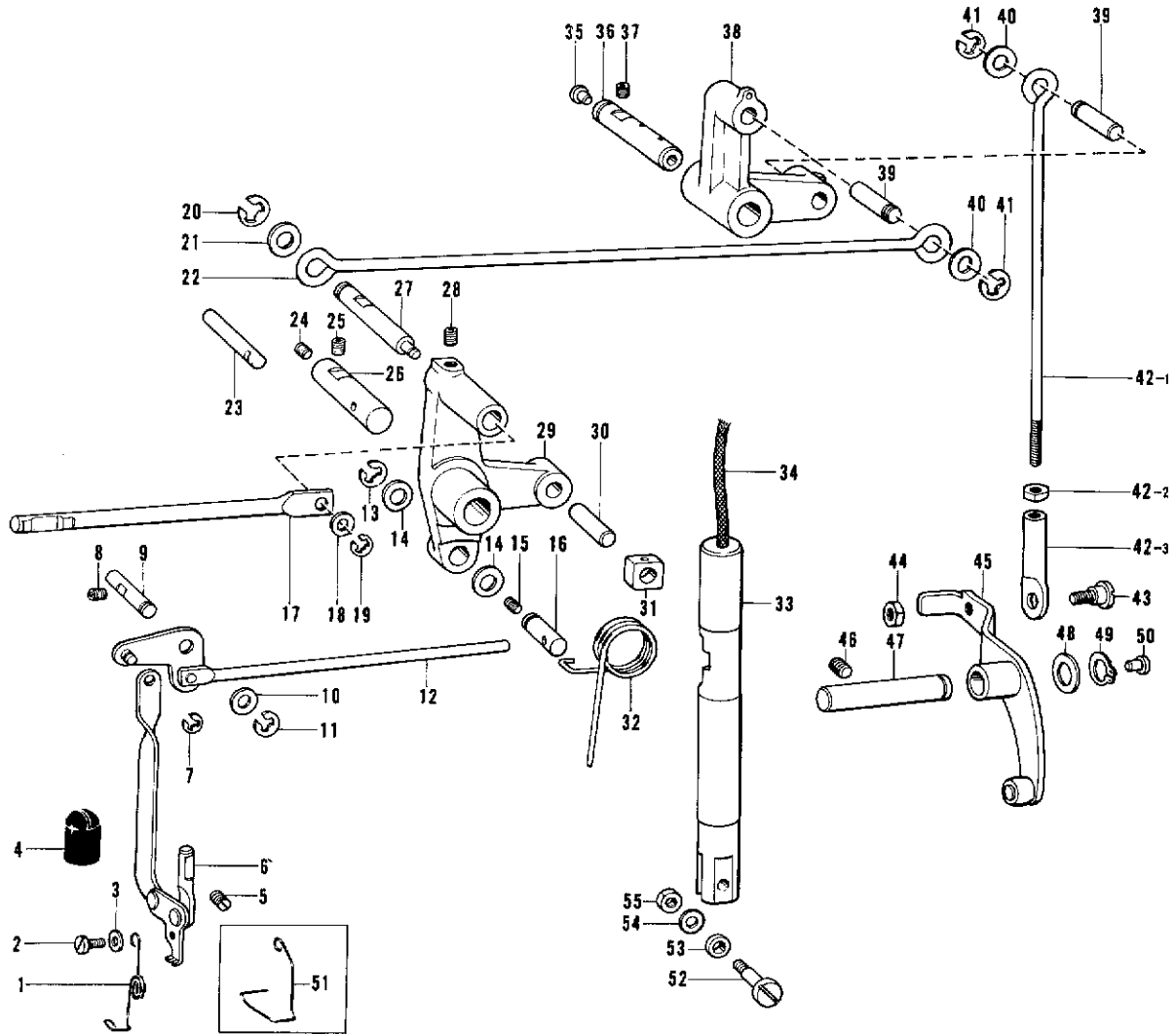

Ref. No.	Name of Parts	Q'ty	Parts No.	Assembly No.	Ref. No.	Name of Parts	Q'ty	Parts No.	Assembly No.
H-1	Thread Wiper	1			H-30	Tack Length Slide Block Pin	1	152744-0-01	
H-2	Screw 3.57 x 5	1	009670-5-12		H-31	Needle Bar Guide Slide Block	1	102630-0-01	
H-3	Washer 3.5	1	025350-1-32		H-32	Spring	1	152800-1-01	
H-4	Oil Cap	1	152827-0-01		H-33	Work Clamp Lifter Rod	1	155566-0-01	
H-5	Screw 4.76	1	013710-7-12		H-34	Wick 4 x 4	1	152968-0-01	
H-6	Thread Wiper Link Assembly	1	152823-0-01		H-35	Cap for Oil Inlet	1	111865-0-01	
H-7	Stop Ring E3	1	048030-3-42		H-36	Lifting Lever Shaft	1	152807-0-01	
H-8	Screw 4.37 x 6	1	014680-6-22		H-37	Screw 5.95 x 6	1	014760-6-22	
H-9	Thread Wiper Shaft	1	152822-0-01		H-38	Connecting Lever	1	152805-0-01	
H-10	Washer 6.35	1	025770-2-32		H-39	Connecting Lever Shaft (B)	2	152806-0-01	
H-11	Stop Ring E4	1	048040-3-42		H-40	Washer	2	107153-0-02	
H-12	Thread Wiper Rod Assembly	1	152816-0-01		H-41	Stop Ring E6	2	048060-3-42	
H-13	Stop Ring E6	1	048060-3-42		H-42-1	Connecting Rod	1	154332-0-01	H-42 Connecting Rod Assembly 152808-1-01
H-14	Washer	2	116629-0-01		H-42-2	Nut 6.35	1	150555-0-01	
H-15	Screw 4.37 x 6	1	014680-6-22		H-42-3	Joint	1	154333-0-01	
H-16	Thread Wiper Rod Shaft	1	152815-0-01		H-43	Screw 6.35	1	141583-0-01	
H-17	Tension Release Pin	1	152874-0-01		H-44	Nut 6.35	1	150555-0-01	
H-18	Washer	1	140208-0-01		H-45	Connecting Lever	1	152811-0-01	
H-19	Stop Ring E4	1	048040-3-42		H-46	Screw 5.95 x 6	1	014760-6-22	
H-20	Stop Ring E6	1	048060-3-42		H-47	Driving Shaft	1	152924-0-01	
H-21	Washer	1	107153-0-02		H-48	Horizontal Feed Crank Ring	1	142628-0-01	
H-22	Work Clamp Lifter Rod (A)	1	152803-0-01		H-49	Stop Ring C11	1	048110-1-42	
H-23	Pin	1	152801-0-01		H-50	Cap for Oil Inlet	1	111865-0-01	
H-24	Screw 5.95	1	013760-6-12		H-51	Finger Guard	1		
H-25	Screw 5.95 x 6	1	014760-6-22		H-52	Screw	1	153828-0-01	
H-26	Work Clamp Lifter Lever Shaft	1	152799-0-01		H-53	Roller	1	107744-0-01	
H-27	Work Clamp Lifter Rod Shaft (A)	1	152802-0-01		H-54	Washer 4.76	1	153484-0-01	
H-28	Screw 5.95 x 6	1	014760-6-22		H-55	Nut 4.37	1	105234-0-03	
H-29	Work Clamp Lifter Lever	1	152798-0-01						

J. Thread Trimming and Thread Nipper Mechanism

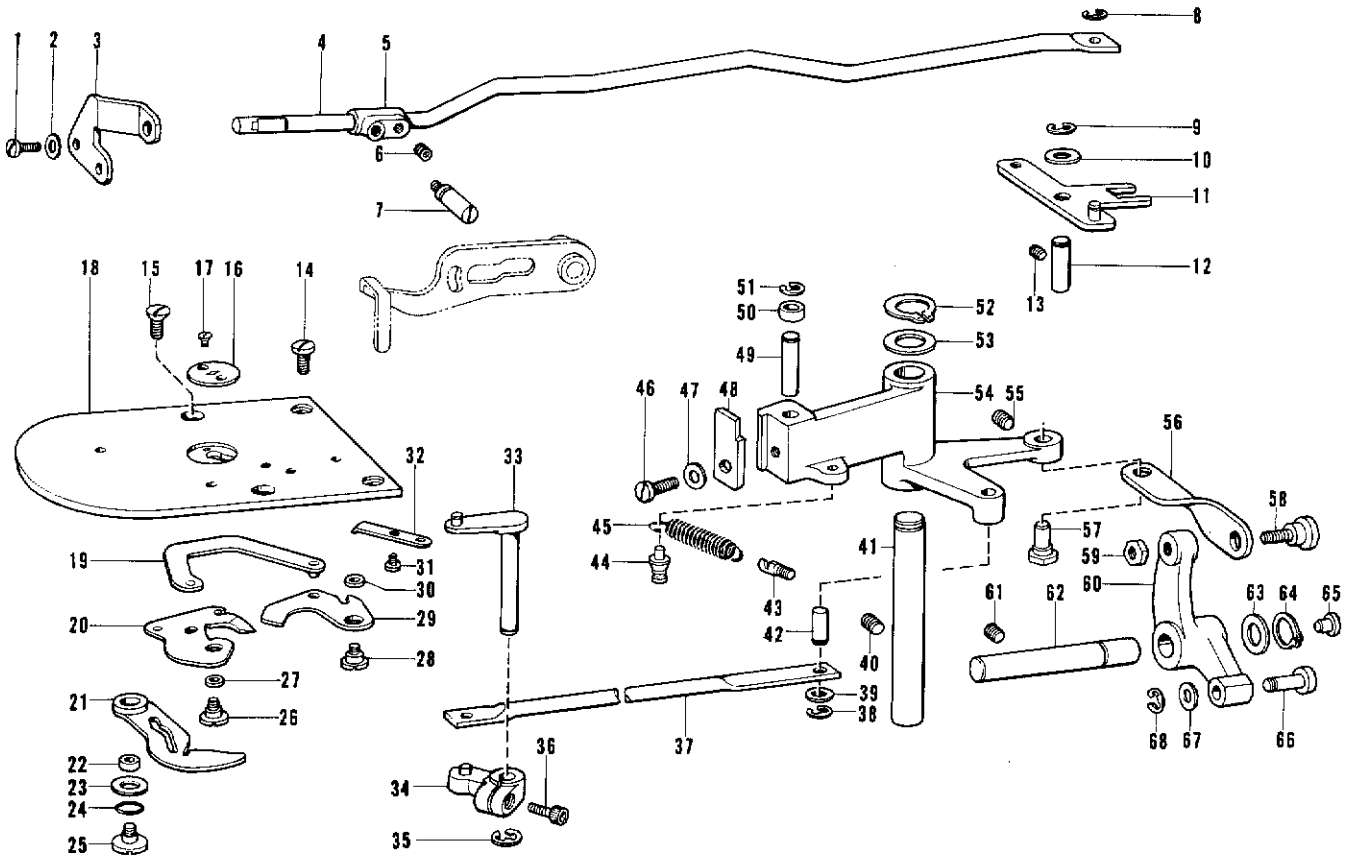

Ref. No.	Name of Parts	Q'ty	Parts No.	Assembly No.	Ref. No.	Name of Parts	Q'ty	Parts No.	Assembly No.
J-1	Screw 3.57 x 10	2	009671-0-12		J-35	Stop Ring E5	1	048050-3-42	
J-2	Washer 3.5	2	025350-3-32		J-36	Bolt 4.37 x 10	1	018681-0-22	
J-3	Tension Release Bar Plate	1	152926-0-01		J-37	Connecting Rod	1	152892-0-01	
J-4	Tension Release Bar	1	152925-1-01		J-38	Stop Ring E4	1	048040-3-42	
J-5	Thread Take-up Guide	1	152886-0-01		J-39	Washer	1	140208-0-01	
J-6	Screw 4.37 x 4	1	014680-4-22		J-40	Screw 5.95 x 6	1	014760-6-22	
J-7	Guide Stud	1	152887-0-01		J-41	Shaft	1	152916-0-01	
J-8	Stop Ring E4	1	048040-3-42		J-42	Pin	1	152919-0-01	
J-9	Stop Ring E5	1	048050-3-42		J-43	Spring Hook	1	141334-0-01	
J-10	Washer 6.35	1	025770-2-32		J-44	Spring Hook	1	154789-0-01	
J-11	Tension Release Lever	1	155571-0-01		J-45	Spring	1	154788-0-01	
J-12	Tension Release Lever Shaft	1	152929-0-01		J-46	Screw 5.95 x 14	1	009761-4-12	
J-13	Screw 5.95 x 6	1	014760-6-22		J-47	Washer 6	1	025060-1-32	
J-14	Screw 4.37	2	153208-0-02		J-48	Cam Lever Claw	1	152915-0-01	
J-15	Screw 4.37	2	100032-0-04		J-49	Roller Stud	1	152913-0-01	
J-16	Needle Hole Plate (B)	1	156150-0-01		J-50	Roller	1	152914-0-01	
J-17	Screw 2.38	2	100360-0-03		J-51	Stop Ring E4	1	048040-3-42	
J-18	Needle Plate (S)	1	152995-0-01		J-52	Stop Ring C12	1	048120-1-42	
J-19	Knife Connecting Rod Assembly	1	152897-1-01		J-53	Washer	1	152917-0-01	
J-20	Movable Knife Assembly	1	152901-0-01		J-54	Cam Lever	1	152912-0-01	
J-21	Thread Retainer (A)	1	152906-1-01		J-55	Screw 5.95 x 6	1	014760-6-22	
J-22	Collar	1	153597-0-01		J-56	Thread Trimming Link	1	152921-0-01	
J-23	Washer	1	153596-0-01		J-57	Stud	1	152920-0-01	
J-24	Packing P8	1	081008-0-70		J-58	Screw 5.95	1	151907-0-01	
J-25	Screw 4.37	1	153598-0-01		J-59	Nut 5.95	1	150553-0-01	
J-26	Screw 4.37	1	152904-0-01		J-60	Thread Trimming Lever	1	152922-0-01	
J-27	Collar	1	153219-0-01		J-61	Screw 5.95 x 6	1	014760-6-22	
J-28	Screw 4.37	1	153222-0-01		J-62	Driving Shaft	1	153482-0-01	
J-29	Knife Arm (C)	1	152981-0-01		J-63	Horizontal Feed Crank Ring	1	142628-0-01	
J-30	Collar	1	153220-0-01		J-64	Stop Ring C11	1	048110-1-42	
J-31	Screw 2.38	2	111140-0-02		J-65	Cap for Oil Inlet	1	111865-0-01	
J-32	Fixed Knife	1	152905-0-01		J-66	Roller	1	152923-0-01	
J-33	Thread Trimming Arm (B)	1	152893-1-01		J-67	Washer	1	112468-0-01	
J-34	Thread Trimming Arm (A) Assembly	1	152896-0-01		J-68	Stop Ring E5	1	048050-3-42	

K. Bobbin Winder and Threading Mechanism

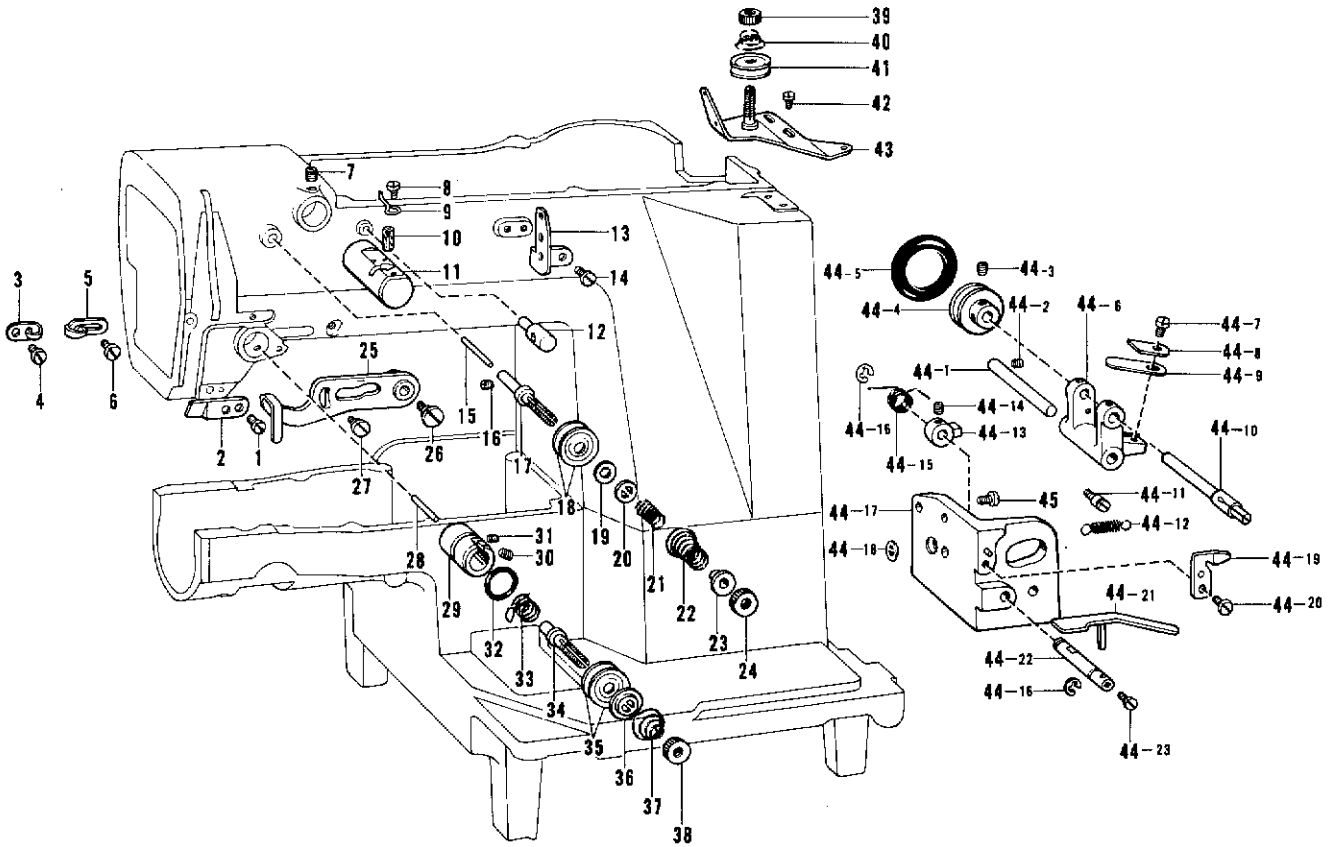

Ref. No.	Name of Parts	Q'ty	Parts No.	Assembly No.	Ref. No.	Name of Parts	Q'ty	Parts No.	Assembly No.
K- 1	Screw 4.76 x 7	1	009710-7-12		K-35	Tension Disc	2	145446-0-01	
K- 2	Arm Thread Guide	1	152869-0-01		K-36	Presser for Tension Disc	1	100134-0-01	
K- 3	Arm Thread Guide	1	152870-0-01		K-37	Tension Spring	1	104525-0-01	
K- 4	Screw 3.57 x 6	1	009670-6-12		K-38	Tension Control Nut	1	100136-0-01	
K- 5	Arm Thread Guide	1	113316-0-01		K-39	Tension Control Nut	1	100136-0-01	
K- 6	Screw 3.57	1	112751-0-03		K-40	Tension Spring	1	104525-0-01	
K- 7	Screw 5.95	1	013760-6-12		K-41	Tension Disc	2	145446-0-01	
K- 8	Screw 3.57 x 4	1	009670-4-12		K-42	Screw 4.37 x 10	2	009681-0-12	
K- 9	Needle Cooler Thread Guide	1	152884-0-01		K-43	Lower Thread Tension Bracket Assembly	1	152945-0-01	
K-10	Felt 7 x 15.5	1	152883-0-00		K-44- 1	Bobbin Winder Lever Shaft	1	152934-0-01	
K-11	Needle Cooler Assembly	1	152881-0-01		K-44- 2	Screw 4.37	1	102716-0-04	
K-12	Upper Thread Guide Bar	1	153049-0-01		K-44- 3	Screw 4.37	2	102716-0-04	
K-13	Thread Retainer	1	152889-0-01		K-44- 4	Bobbin Winder Wheel	1	154528-0-01	
K-14	Screw 3.57 x 6	2	009670-6-12		K-44- 5	Rubber Ring	1	120448-0-01	
K-15	Tension Release Pin	1	152876-0-01		K-44- 6	Bobbin Winder Lever	1	152984-0-01	
K-16	Screw 4.37	1	151601-0-02		K-44- 7	Screw 3.57 x 7	1	009670-7-12	
K-17	Tension Stud	1	152875-0-01		K-44- 8	Washer	1	152937-0-01	
K-18	Tension Disc	2	145446-0-01		K-44- 9	Plate Spring	1	152936-0-01	
K-19	Washer	1	153138-0-01		K-44-10	Bobbin Winder Shaft	1	152933-0-01	
K-20	Tension Disc Washer	1	152877-0-01		K-44-11	Sustainer	1	141550-0-01	K-44
K-21	Tension Spring	1	152878-0-01		K-44-12	Spring	1	152939-0-01	Bobbin
K-22	Tension Spring	1	152879-1-01		K-44-13	Claw for Bobbin Winder	1	142566-0-01	Winder
K-23	Washer	1	152880-0-01		K-44-14	Screw 4.37	2	151601-0-01	Assembly
K-24	Tension Control Nut	1	100136-0-01		K-44-15	Spring	1	152941-0-01	152982-1-01
K-25	Thread Take-up Lever	1	152888-0-01		K-44-16	Stop Ring E5	2	048050-3-42	
K-26	Screw 6.35	1	141528-0-01		K-44-17	Bobbin Winder Bracket	1	152983-0-01	
K-27	Screw 4.76	1	115077-0-03		K-44-18	Spring Hook	1	115138-0-01	
K-28	Tension Release Pin	1	152873-0-01		K-44-19	Knife	1	152938-0-01	
K-29	Tension Bracket	1	152872-0-01		K-44-20	Screw 4.37 x 7	1	009680-7-12	
K-30	Screw 5.95	1	103950-0-02		K-44-21	Bobbin Presser	1	152935-0-01	
K-31	Screw 3.57	1	100402-0-04		K-44-22	Claw Stud for Bobbin Winder	1	152940-0-01	
K-32	Packing	1	114294-0-01		K-44-23	Screw 3.57 x 7	1	009670-7-12	
K-33	Thread Take-up Spring	1	145519-0-01		K-45	Screw 5.95 x 14	2	009761-4-12	
K-34	Tension Stud	1	100398-0-01						

L. Oil Pan

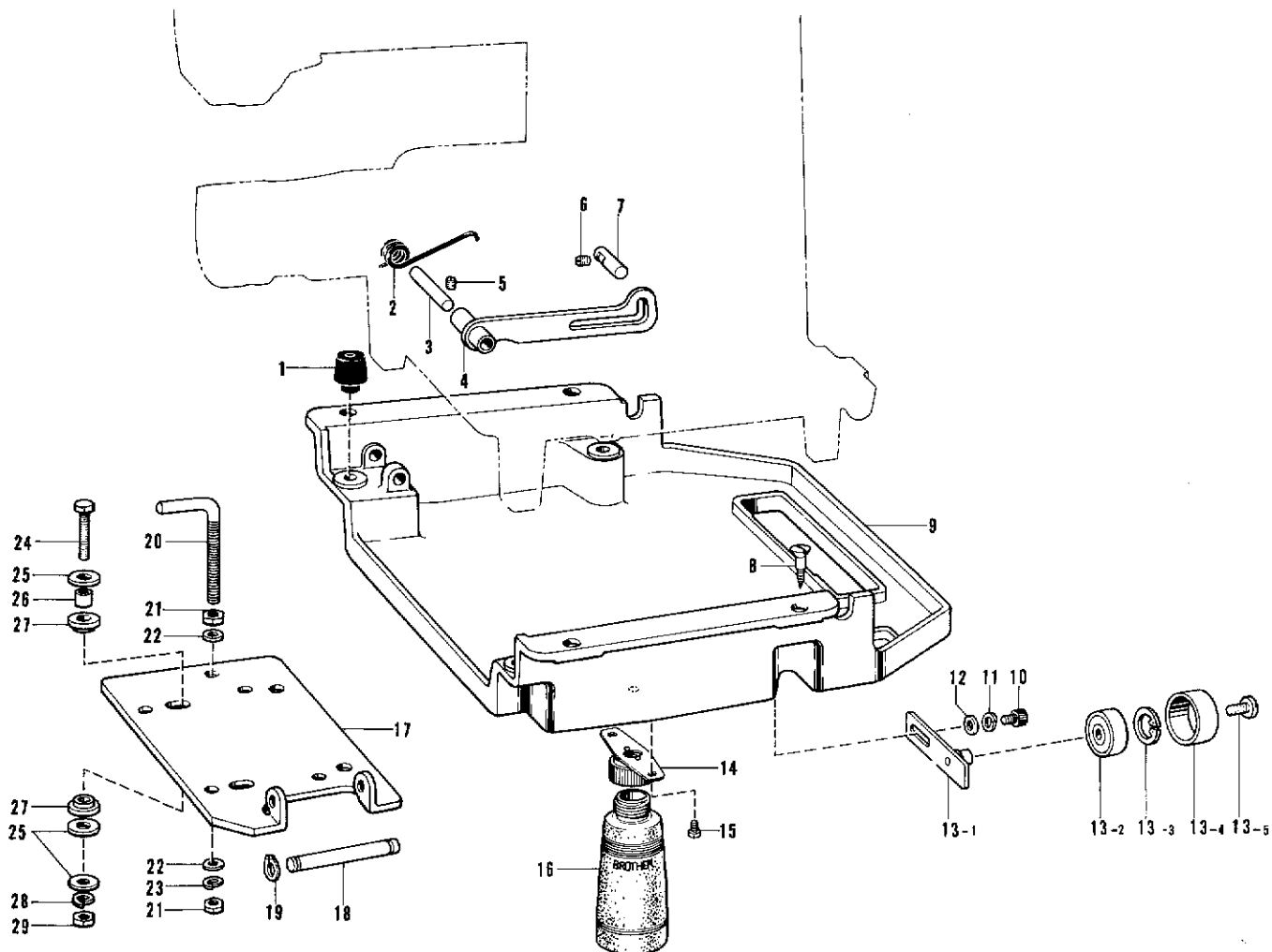

Ref. No.	Name of Parts	Q'ty	Parts No.	Assembly No.	Ref. No.	Name of Parts	Q'ty	Parts No.	Assembly No.
L- 1	Bed Cushion	4	152860-0-01		L-14	Dust Oiler Supporter	1	154465-0-01	
L- 2	Head Supporter Lever Spring	1	152859-0-01		L-15	Screw 4.76 x 6	2	009710-6-12	
L- 3	Head Supporter Lever Shaft	1	152858-0-01		L-16	Oiler	1	114486-0-01	
L- 4	Head Supporter Lever	1	152857-0-01		L-17	Motor Base Plate	1	152861-J-01	
L- 5	Screw 4.76	1	013719-4-12		L-18	Motor Base Plate Shaft	1	152862-0-01	
L- 6	Screw 5.95	1	013760-6-12		L-19	Stop Ring C10	2	048100-1-42	
L- 7	Pin	1	152866-0-01		L-20	Bolt M10	1	152865-0-01	
L- 8	Screw 6.2 x 32	4	106030-0-01		L-21	Nut 10	2	021100-2-02	
L- 9	Oil Pan	1	154738-0-01		L-22	Washer 10	2	025100-1-32	
L-10	Bolt 8 x 12	1	018081-2-22		L-23	Washer 2-10	1	028100-2-42	
L-11	Washer 2-8	1	028080-2-42		L-24	Bolt 6 x 25	4	017062-5-03	
L-12	Washer 8	1	025080-2-32		L-25	Washer 7.14	12	025800-3-33	
L-13-1	Tension Pulley Plate	1		L-13 Tension Pulley Assembly 152852-1-01	L-26	Cushion Collar	4	152863-0-01	
L-13-2	Ball Bearing 6201VV	1			L-27	Cushion	8	152864-0-00	
L-13-3	Stop Ring C32	1	048320-2-42		L-28	Washer 2-6	4	028060-2-42	
L-13-4	Tension Pulley	1			L-29	Nut 6	4	021060-1-02	
L-13-5	Screw 6.35	1	141860-0-01						

M. Lubrication

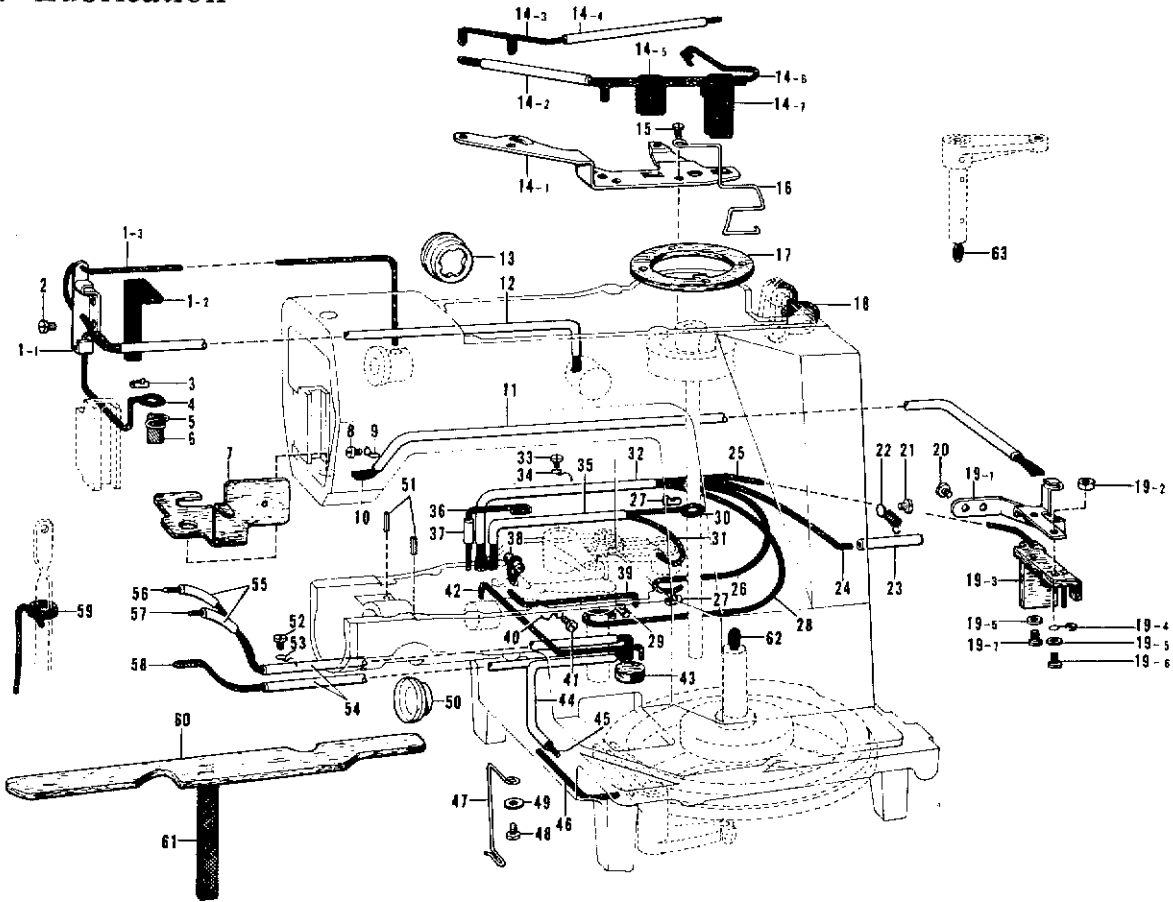

Ref. No.	Name of Parts	Q'ty	Parts No.	Assembly No.	Ref. No.	Name of Parts	Q'ty	Parts No.	Assembly No.
M- 1-1	Wick Supporter	1	152959-0-01	M-1	M-26	Wick 4 x 4	1	152965-0-01	
M- 1-2	Wick	1	152955-0-01	M-1	M-27	Wick Supporter	2	104567-0-01	
M- 1-3	Wick 4 x 4	1	152956-0-01	M-1	M-28	Wick 4 x 4	1	153922-0-01	
M- 2	Screw 4.37 x 6	1	009680-6-12	M-1	M-29	Wick Supporter	1	104567-0-01	
M- 3	Wick Supporter	1	104567-0-01	M-1	M-30	Wick 6 x 6	1	152964-0-01	
M- 4	Wick 4 x 4	1	152956-0-01	M-1	M-31	Wick 6 x 6	1	152964-0-01	
M- 5	Wick Supporter	1	152962-0-01	M-1	M-32	Oil Tube	1	148921-0-00	
M- 6	Wick	1	152960-0-01	M-1	M-33	Screw 3.57 x 5	1	009670-5-12	
M- 7	Felt	1	153530-0-01	M-1	M-34	Cord Supporter	1	152969-0-01	
M- 8	Screw 3.57 x 5	1	009670-5-12	M-1	M-35	Oil Tube	1	147745-0-00	
M- 9	Cord Supporter	1	117150-0-01	M-1	M-36	Wick 4 x 4	1	152974-0-01	
M-10	Wick	1	152992-0-01	M-1	M-37	Oil Tube	1	148735-0-01	
M-11	Oil Tube	1	146375-0-00	M-1	M-38	Felt	1	153924-0-01	
M-12	Oil Tube	1	144694-0-01	M-1	M-39	Wick 4 x 4	1	153921-0-01	
M-13	Oil Gauge Window	1	152948-0-01	M-1	M-40	Cord Supporter	1	117150-0-01	
M-14-1	Wick Supporter	1	152950-0-01	M-14	M-41	Screw 3.57 x 5	1	009670-5-12	
M-14-2	Oil Tube	1	140423-0-00	M-14	M-42	Wick 4 x 4	1	152973-0-01	
M-14-3	Wick 6 x 6	1	153919-0-01	M-14	M-43	Felt	1	113006-0-01	
M-14-4	Oil Tube	1	147745-0-00	M-14	M-44	Oil Tube	1	147745-0-00	
M-14-5	Felt	1	152952-0-01	M-14	M-45	Wick 6 x 6	1	152953-0-01	
M-14-6	Wick 6 x 6	1	153918-0-01	M-14	M-46	Wick 4 x 4	1	152985-0-01	
M-14-7	Felt	1	152951-0-01	M-14	M-47	Wick Supporter	1	153763-0-01	
M-15	Screw 4.37 x 10	2	009681-0-12	M-14	M-48	Screw 3.57 x 5	1	009670-5-12	
M-16	Felt Supporter	1	153528-0-01	M-14	M-49	Washer	1	105248-0-01	
M-17	Felt	1	153529-0-01	M-14	M-50	Oil Gauge Window	1	152948-0-01	
M-18	Wick 6 x 6	1	153927-0-01	M-14	M-51	Pin	2	047251-6-40	
M-19-1	Felt Supporter	1	152966-0-01	M-14	M-52	Screw 3.57 x 5	1	009670-5-12	
M-19-2	Nut 3.57	1	021670-2-02	M-14	M-53	Cord Supporter	1	152969-0-01	
M-19-3	Felt	1	152967-0-01	M-19	M-54	Oil Tube	2	140423-0-00	
M-19-4	Tube Stopper	1	141692-0-01	M-19	M-55	Oil Tube	2	148735-0-01	
M-19-5	Washer 3.5	3	025350-3-32	M-19	M-56	Wick 4 x 4	1	152972-0-01	
M-19-6	Screw 3.57 x 14	1	009671-4-12	M-19	M-57	Wick 4 x 4	1	153920-0-01	
M-19-7	Screw 3.57 x 8	2	009670-8-12	M-19	M-58	Wick 4 x 4	1	152971-0-01	
M-20	Screw 3.57 x 6	2	009670-6-12	M-19	M-59	Wick 4 x 4	1	152973-0-01	
M-21	Screw 4.37 x 8	1	009680-8-12	M-19	M-60	Felt	1	153531-0-01	
M-22	Tube Supporter	1	152978-0-01	M-19	M-61	Wick	1	153562-0-01	
M-23	Oil Tube	1	148735-0-01	M-19	M-62	Wick 6 x 6	1	152980-0-01	
M-24	Wick 4 x 4	1	153922-0-01	M-19	M-63	Wick 6 x 6	1	152980-0-01	
M-25	Wick 4 x 4	1	152963-0-01						

Z. Accessories

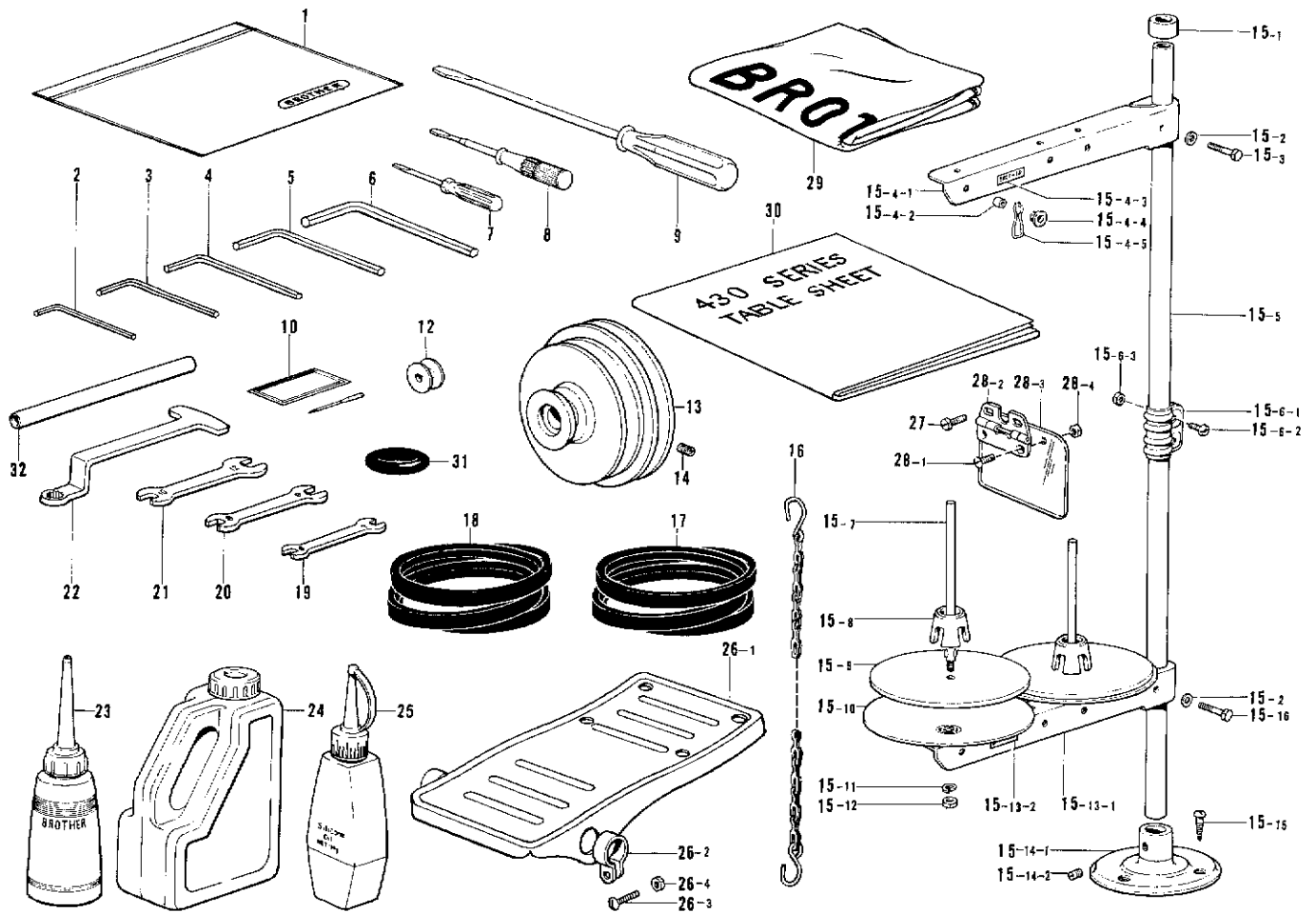

Ref. No.	Name of Parts	Q'ty	Parts No.	Assembly No.	Ref. No.	Name of Parts	Q'ty	Parts No.	Assembly No.
Z-1	Vinyl Bag		122991-0-01		Z-15-13-1	Spool Holder 2			Z-15-13 Spool Holder Assembly 150177-0-01
Z-2	Spanner 2		142002-0-01		Z-15-13-2	Name Plate			
Z-3	Spanner 3		142721-0-01		Z-15-14-1	Cotton Stand Base		150189-0-01	Z-15-14 Cotton Stand Base Assembly 150139-0-01
Z-4	Spanner 4		118064-0-01		Z-15-14-2	Screw 6 x 10		150181-0-01	
Z-5	Spanner 5		147487-0-01		Z-15-15	Screw 4.5 x 22		031452-2-03	Z-15 Cotton Stand Assembly 150150-0-01
Z-6	Spanner 6		115157-0-01		Z-15-16	Bolt 5 x 28		017502-8-03	
Z-7	Screw Driver 1.9 x 52		142443-0-01		Z-16	Chain		149247-0-01	
Z-8	Screw Driver 3.4 x 70		118837-0-01		Z-17	V Belt (for Low Speed)		082104-8-90	
Z-9	Screw Driver 5.5 x 190		101572-1-01		Z-18	V Belt (for High Speed)			
Z-10	Needle DP x 5 #14 Assembly		107415-4-14		Z-19	Spanner 6 x 7		107779-0-01	
Z-12	Bobbin		145265-0-01		Z-20	Spanner 8 x 9		100887-0-01	
Z-13	Motor Pulley				Z-21	Spanner 10 x 12		107780-0-01	
Z-14	Screw 5.95 x 6		014760-6-22		Z-22	Wrench 10		152765-0-01	
Z-15-1	Cap			Z-15 Cotton Stand Assembly 150150-0-01	Z-23	Oiler		114483-0-01	
Z-15-2	Washer 5		025050-2-33		Z-24	Oil Tank		154702-0-01	
Z-15-3	Bolt 5 x 28		017502-8-03		Z-25	Silicon Oil		156334-0-02	
Z-15-4-1	Spool Holder 2			Z-15-4 Thread Hanger Assembly 150192-0-01	Z-26-1	Pedal		117437-1-01	Z-26 Pedal Assembly 116185-2-01
Z-15-4-2	Thread Bushing		142990-0-01		Z-26-2	Pedal Stopper		116016-0-01	
Z-15-4-3	Name Plate				Z-26-3	Screw 4 x 14		001401-4-16	
Z-15-4-4	Thread Hanger				Z-26-4	Nut 4		021400-1-06	
Z-15-4-5	Thread Guide Spring		150184-0-01		Z-27	Screw 3.57 x 5			
Z-15-5	Pipe		150172-0-01		Z-28-1	Screw 3.57		102538-0-07	
Z-15-6-1	Joint		150173-0-01	Z-15-6 Joint for Cotton Stand 150106-0-01	Z-28-2	Eye Guard Hinge Assembly		153102-0-01	Z-28 Eye Guard Assembly
Z-15-6-2	Screw 5 x 14		150202-0-01		Z-28-3	Eye Guard		153098-0-00	
Z-15-6-3	Nut 5		021500-1-03		Z-28-4	Nut 3.57		106129-0-01	
Z-15-7	Spool Shaft (B)		150179-0-01		Z-29	Head Cover		144226-0-01	
Z-15-8	Spool Cushion		126863-0-00	Z-15 Cotton Stand Assembly 150150-0-01	Z-30	Table Sheet		153574-2-01	
Z-15-9	Spool Mat		150182-0-00		Z-31	Rubber Ring		120448-0-01	
Z-15-10	Spool Stand Base		150180-0-00		Z-32	Pipe		154760-0-01	
Z-15-11	Washer 2-5		028050-2-43						
Z-15-12	Nut 5		021500-1-03						







*The details of included accessories are subject to change.

*Änderungen in der Aufstellung der mitgelieferten Zubehöre sind vorbehalten.

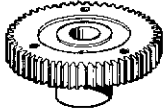
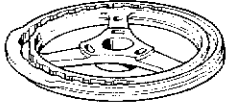
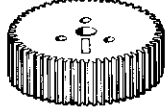
*Les détails des accessoires inclus sont sujets à des changements.

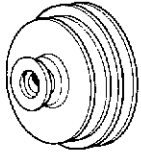
*Los detalles de los accesorios incluidos pueden variar.

DIFFERENT PARTS LIST

Ref. No.	Name of Parts	Sub-class	-1		-2	
			Standard	With Finger Guard & Eye Guard	Standard	With Finger Guard & Eye Guard
A-28		Label	153056-0-01		153056-0-02	
G- 4		Change Gear C	152722-0-00		152720-0-00	
G- 5		Feed Cam	153344-0-01		153343-0-01	
G-40		Change Gear W	152721-0-00		152719-0-00	
H- 1		Thread Wiper	152828-0-01	/	152828-0-01	/
H-51		Finger Guard	/	153046-0-01	/	153046-0-01
Z-13		Motor Pulley	50Hz	154540-0-01 (φ14) 154542-0-01 (φ15.88)		
			60Hz	154541-0-01 (φ14) 154543-0-01 (φ15.88)		
Z-18		V Belt	50Hz	082105-2-90		
			60Hz	082105-1-90		
Z-27		Screw 3.57 x 5	/	009670-5-12	/	009670-5-12
Z-28		Eye Guard Assembly	/	153100-0-00	/	153100-0-00

INDEX

Parts No.	Ref. No.	Remark	Parts No.	Ref. No.	Remark	Parts No.	Ref. No.	Remark	Parts No.	Ref. No.	Remark
001401-4-16	Z-26- 3		014760-6-22	F-26		025060-2-32	B-30		048350-2-42	D- 7	
009660-3-12	B-54			F-27			D-43		048620-2-42	C- 5	
009660-7-12	B-57			F-35			E- 5		071047-6-50	E-28	
	C-19			F-37			E-10-10		071095-2-50	C-20	
009670-4-12	G-28			G-19			E-19		072600-3-60	D- 8	
	K- 8			G-47		025080-2-32	L-12		072600-7-60	C- 7	
009670-5-12	C-60			H-25		025100-1-32	L-22		072630-2-60	B-26	
	H- 2			H-28		025350-1-32	H- 3		081003-6-70	B-46	
	M- 8			H-37		025350-3-32	J- 2			B-49	
	M-33			H-46			M-19- 5		081008-0-70	J-24	
	M-41			J-13		025680-1-33	C-35- 6		082104-8-90	Z-17	
	M-48			J-40		025710-1-32	E-10-19		082105-1-90	Z-18	
	M-52			J-55			E-10-32		082105-2-90	Z-18	
	Z-27			J-61		025710-2-32	E-10-25		100032-0-04	J-15	
009670-6-12	K- 4			Z-14			E-10-36		100134-0-01	K-36	
	K-14		014770-6-22	B-13		025770-2-32	A-36		100136-0-01	K-24	
	M-20			B-14			H-10			K-38	
009670-7-12	K-44- 7			B-48			J-10			K-39	
	K-44-23			C- 2		025800-3-33	C-67		100250-0-01	B-17	
009670-8-12	A- 7			G-22			L-25		100253-0-01	B- 7- 5	
	M-19- 7		014821-0-22	C-43		028040-2-42	C-59		100315-0-02	A-34	
009671-0-12	J- 1			D-15		028050-2-42	C-39		100360-0-03	J-17	
009671-4-12	M-19- 6		017062-5-03	L-24			D-36		100398-0-01	K-34	
009680-6-12	A-45		017502-8-03	Z-15- 3		028050-2-43	Z-15-11		100402-0-04	K-31	
	M- 2			Z-15-16		028060-2-42	D-52		100887-0-01	Z-20	
009680-7-12	K-44-20		017711-4-12	D-37 - C-40			G- 7		101572-1-01	Z- 9	
009680-8-12	A-18		017761-4-12	B-31			L-28		101706-0-01	B-15	
	A-22			E-18		028080-2-42	C-53		102538-0-07	Z-28- 1	
	B- 7- 1		017762-2-02	D-49			L-11		102630-0-01	H-31	
	M-21		018060-8-22	D- 5- 2		028100-2-42	L-23		102716-0-04	K-44- 2	
009681-0-12	E-10-20		018061-0-22	E-10- 9		031452-2-03	Z-15-15			K-44- 3	
	K-42		018061-6-22	D-53		046301-6-20	B-42- 2		102843-0-04	B-29	
	M-15			G-44		046302-0-20	G-45- 1- 3		103950-0-02	K-30	
009710-6-12	L-15		018062-0-22	E- 6		047251-6-40	M-51		104450-0-01	A-37	
009710-7-12	A- 1			G- 8		047501-2-42	A-15			A-41	
	K- 1			G-14		048030-3-42	C-35- 1		104525-0-01	K-37	
009711-4-12	A- 3			G-53			H- 7			K-40	
	A-12		018062-2-22	G-42		048040-3-42	C- 1- 3		104567-0-01	M- 3	
009761-0-12	E-10-14		018063-0-22	F-20			C-30			M-27	
009761-4-12	A-11			G- 3			E-10-31			M-29	
	J-46			G-26			G-45- 5		104689-0-01	B-35	
	K-45			G-37			G-54- 4			C-69	
009781-4-12	B-10		018081-2-22	L-10			H-11		105234-0-03	H-55	
013710-7-12	G-31		018082-0-22	F- 5- 2			H-19		105248-0-01	M-49	
	G-33			F-33- 2			J- 8		105451-0-02	F- 8	
	H- 5		018082-5-22	C-54			J-38			F-28	
013719-4-12	L- 5		018401-6-22	E-10-24			J-51		106030-0-01	L- 8	
013760-6-12	H-24		018500-8-22	E-10-46		048050-3-42	J- 9		106129-0-01	Z-28- 4	
	K- 7		018501-2-22	E-10-48			J-35		106147-0-01	C-21	
	L- 6		018501-4-22	B-62			J-68		107030-0-01	G-52- 3	
013761-4-10	C-26		018681-0-22	E-11			K-44-16		107149-0-01	B-33	
	D-27			J-36		048060-3-42	H-13		107153-0-02	H-21	
013761-4-12	B-12		021060-1-02	L-29			H-20			H-40	
	B-18		021100-2-02	L-21			H-41		107231-0-02	D-10	
014680-4-22	J- 6		021400-1-03	E-10-30		048080-3-42	B-61		107415-0-14	B- 1	
014680-6-22	B-36		021400-1-06	Z-26- 4		048100-1-42	L-19		107415-4-14	Z-10	
	E-16		021500-1-03	Z-15- 6- 3		048110-1-42	C-27		107744-0-01	C-35- 3	
	H- 8			Z-15-12			D-33			H-53	
	H-15		021670-2-02	M-19- 2			H-49		107779-0-01	Z-19	
014760-6-22	B-38		021680-2-02	C-35- 7			J-64		107780-0-01	Z-21	
	B-41			E-10-40		048120-1-42	J-52		108520-0-01	A-31	
	B-44			E-10-41		048150-1-42	B-23		109239-0-02	A-48	
	B-51			E-14		048160-1-42	D-16		109893-0-02	G- 6	
	C-51		021680-3-03	E-10- 3		048170-1-42	D- 1		110027-0-01	G-46	
	D-12		021710-2-12	E-10- 6		048180-1-42	C-41		110251-0-01	C-23	
	D-18- 2			E-10-37			F-18			D-45	
	D-19		021800-1-03	C-68			F-21		110495-0-03	B-47	
	E- 4		025050-2-33	Z-15- 2		048240-2-42	C- 9		110505-0-01	D-32	
	F- 6		025060-1-32	D-51		048320-2-42	L-13- 3		111140-0-02	J-31	
	F-15			J-47		048350-1-42	C- 6		111865-0-01	D-20	

Parts No.	Ref. No.	Remark	Parts No.	Ref. No.	Remark	Parts No.	Ref. No.	Remark	Parts No.	Ref. No.	Remark
111865-0-01	D-30		141816-0-01	G-21		151887-0-01	C-42		152245-0-01	B-39	
	H-35		141860-0-01	L-13- 5		151888-1-01	C-52		152246-0-01	B-40	
	H-50		142002-0-01	Z- 2		151889-0-01	C-62		152247-0-01	B-37	
	J-65		142211-0-01	B- 8		151890-0-00	C-63		152250-0-01	B-43	
112468-0-01	J-67		142443-0-01	Z- 7		151891-0-01	C-65		152676-0-01	B-45	
112751-0-03	K- 6		142566-0-01	K-44-13		151892-0-01	C-64		152677-0-01	B-52	
113006-0-01	M-43		142628-0-01	C-28		151893-0-01	C-61		152678-0-01	B-50	
113316-0-01	K- 5			D-29		151894-0-01	C-29		152679-0-01	B-53	
113431-0-02	C-35- 2			H-48		151895-0-00	C-32		152680-0-01	B-55	
	D-35			J-63		151898-0-01	C-31		152681-1-01	B-63	
114294-0-01	K-32		142721-0-01	Z- 3		151899-0-01	C-33		152682-0-01	B-65	
114483-0-01	Z-23		142990-0-01	Z-15- 4- 2		151900-0-01	C-25		152683-0-01	B-60	
114486-0-01	L-16		144226-0-01	Z-29		151901-0-01	C-50		152684-0-01	B-59	
114985-0-01	A-44		144458-0-01	B- 3		151902-0-01	C-24		152685-0-01	B-64	
115003-0-01	C- 1- 6		144694-0-01	M-12		151903-0-01	C-22		152688-1-01	B-67	
115012-0-02	C-55		144712-0-02	B-32- 1		151904-1-01	C-35		152693-0-01	C- 1- 5	
115018-0-01	C-66			B-66		151905-1-01	C-35- 5		152694-0-01	C- 1- 4	
115077-0-03	K-27			Z-12		151906-1-01	C-35- 4		152695-0-01	C- 4	
115138-0-01	K-44-18		145318-0-01	E-26		151907-0-01	C-34		152698-0-01	C-13	
115147-0-01	E- 8		145446-0-01	K-18			G-50		152699-0-01	C- 8	
115157-0-01	Z- 6			K-35			J-58		152700-0-00	C-12	
115493-0-02	A-49			K-41		151908-0-01	C-36		152701-0-01	C-11	
116016-0-01	Z-26- 2		145480-0-01	A-32		151910-0-01	C-38		152702-0-01	C-16	
116185-2-01	Z-26		145519-0-01	K-33		151912-0-01	D-26		152703-0-00	C-15	
116629-0-01	H-14		146375-0-00	M-11		151913-0-01	D-40		152704-0-00	C-14	
116920-0-01	B-24		146994-0-01	E- 9		151914-0-01	D-39		152705-0-01	C-17	
117143-0-01	E-10-18		147111-0-01	C- 3		151915-0-01	G-52		152706-0-01	C-18	
117150-0-01	M- 9		147151-0-00	G-16		151919-1-01	D-31		152707-0-01	G-15	
	M-40		147487-0-01	Z- 5		151920-0-01	D-34		152708-0-00	G-12	
			147745-0-00	M-14- 4		151922-0-01	D-48		152709-0-00	G-11	
117437-1-01	Z-26- 1			M-35		151923-0-01	D-47		152710-0-01	G-13	
117934-0-01	A- 2			M-44		151924-0-01	D-46		152711-0-00	G-20	
117936-0-01	A- 6		148417-0-01	E-10-44		151925-0-01	D-28		152712-0-01	G-39	
118064-0-01	Z- 4			E-13		151927-0-01	C-49		152713-0-01	G-18	
118244-0-01	E-10-23		148735-0-01	M-23		151928-0-01	D-11		152715-0-01	G-23	
	E-10-45			M-37		151929-0-00	C-46		152718-0-01	G-17	
118247-0-01	E-10-21			M-55		151932-0-01	D- 9		152719-0-00	G-40	
	E-10-28		148921-0-00	M-32		151933-0-01	D- 5- 1		152720-0-00	G- 4	
118248-0-01	E-10-12		149247-0-01	Z-16		151935-0-00	D- 5- 1- 1		152721-0-00	G-40	
118249-0-01	E-10-16		150106-0-01	Z-15- 6		151936-0-01	D- 3		152722-0-00	G- 4	
118250-0-01	E-10-15		150139-0-01	Z-15-14		151937-0-01	D- 2		152723-0-01	G-38	
118251-0-01	E-10-17		150150-0-01	Z-15		151938-0-01	D- 4		152724-0-01	G- 1	
118252-0-01	E-10-22		150172-0-01	Z-15- 5		151939-0-01	G-54		152725-0-00	F-19	
118253-0-01	E-10-13		150173-0-01	Z-15- 6- 1		151940-0-01	D- 5- 3			G- 2	
118256-0-01	E-10- 4		150177-0-01	Z-15-13		151941-0-01	D- 5- 4			G-25	
118257-0-01	E-10- 1		150179-0-01	Z-15- 7		151944-0-01	D-18			G-36	
118258-0-01	E-10- 5		150180-0-00	Z-15-10		151946-0-00	C-10		152728-0-01	C-47	
118259-0-01	E-10- 2		150181-0-01	Z-15-14- 2		151947-1-01	D-18- 3			G- 9	
118719-0-01	A-33		150182-0-00	Z-15- 9		151948-0-01	D-18- 4		152729-0-01	G-24	
118837-0-01	Z- 8		150184-0-01	Z-15- 4- 5		151949-0-01	D-23		152730-0-01	G-35	
120448-0-01	K-44- 5		150189-0-01	Z-15-14- 1		151951-0-01	D-22		152731-0-01	G-30	
	Z-31		150192-0-01	Z-15- 4		151952-0-01	D-14		152732-0-01	G-32	
122991-0-01	Z- 1		150202-0-01	Z-15- 6- 2		151953-0-01	D-17		152733-0-01	G-27	
126863-0-00	Z-15- 8		150553-0-01	D-44		151954-0-01	D-13		152734-0-01	G-43	
140208-0-01	H-18			G-51		151995-0-01	B-20		152735-1-01	G-45	
	J-39			J-59		151997-0-00	B-25		152738-0-01	F-36- 2	
140392-0-01	A- 5		150553-0-02	E-10-26		151998-0-00	B-27		152739-0-01	G-45- 3	
140423-0-00	M-14- 2		150554-0-02	C-56		151999-0-01	B-28		152742-0-01	F- 1	
	M-54		150555-0-01	D-25- 2		152000-0-01	B-19		152744-0-01	H-30	
140726-0-00	B-21			H-42- 2		152191-0-01	B-42		152745-0-01	F- 7	
141331-0-01	E-27- 1			H-44		152231-0-00	B-16			F-34	
141334-0-01	G-49		150556-0-01	D-24		152232-0-01	B- 7		152749-0-01	F-11	
	J-43			D-38		152236-0-01	B- 7- 3			F-31	
141472-0-02	D-21		151163-0-01	C-48		152237-0-01	B- 7- 7		152750-0-01	F-10	
141528-0-01	K-26			G-10		152238-0-01	B- 7- 6			F-30	
141550-0-01	K-44-11		151601-0-01	K-44-14		152239-0-01	B- 7- 2		152752-0-01	F-13	
141583-0-01	H-43		151601-0-02	K-16		152240-0-01	B- 6		152755-0-01	F-16	
141692-0-01	M-19- 4		151602-0-02	F- 4		152242-0-01	B-11		152756-0-01	C-44	
141786-0-01	B-34		151604-0-02	A-27		152243-0-01	B- 5			F-17	
141808-0-01	A-40		151886-0-01	C-45		152244-0-00	B- 9			F-22	

Parts No.	Ref. No.	Remark	Parts No.	Ref. No.	Remark	Parts No.	Ref. No.	Remark	Parts No.	Ref. No.	Remark
152756-0-01	F-24		152888-0-01	K-25		152978-0-01	M-22		153924-0-01	M-38	
152758-0-01	F-23		152889-0-01	K-13		152980-0-01	M-62		153925-0-01	B-22	
152759-0-01	E-24		152890-0-01	B- 2			M-63		153926-0-01	F- 3	
152760-0-01	F-25		152891-0-01	B- 4		152981-0-01	J-29		153927-0-01	M-18	
152765-0-01	Z-22		152892-0-01	J-37		152982-1-01	K-44		153941-0-01	E-10-47	
152766-0-01	E-25		152893-1-01	J-33		152983-0-01	K-44-17			E-12	
152769-0-01	E-27		152896-0-01	J-34		152984-0-01	K-44- 6		154155-1-01	D-41	
152771-0-00	E-27- 4		152897-1-01	J-19		152985-0-01	M-46		154176-0-01	J-20	
152772-0-01	E-29		152904-0-01	J-26		152986-0-01	A-21		154332-0-01	D-25- 3	
152773-0-00	E-27- 2		152905-0-01	J-32		152989-0-01	A-17			H-42- 1	
152798-0-01	H-29		152912-0-01	J-54		152992-0-01	M-10		154333-0-01	D-25- 1	
152799-0-01	H-26		152913-0-01	G-54- 3		152995-0-01	J-18			H-42- 3	
152800-1-01	H-32			J-49		153035-0-00	E-23		154465-0-01	L-14	
152801-0-01	H-23		152914-0-01	E-10- 7		153040-0-01	B-32		154528-0-01	K-44- 4	
152802-0-01	H-27			G-34		153041-0-01	F- 2		154531-1-01	J-21	
152803-0-01	H-22			G-54- 2		153042-0-01	F-12		154540-0-01	Z-13	
152805-0-01	H-38			J-50			F-32		154541-0-01	Z-13	
152806-0-01	H-39		152915-0-01	J-48		153043-0-01	F-14		154542-0-01	Z-13	
152807-0-01	H-36		152916-0-01	J-41			F-38		154543-0-01	Z-13	
152808-1-01	D-25		152917-0-01	J-53		153044-0-01	C- 1		154702-0-01	Z-24	
	H-42		152919-0-01	J-42		153045-0-01	F- 9		154738-0-01	L- 9	
152811-0-01	H-45		152920-0-01	J-57			F-29		154760-0-01	Z-32	
152815-0-01	H-16		152921-0-01	J-56		153046-0-01	H-51		154785-0-00	A-14	
152816-0-01	H-12		152922-0-01	J-60		153049-0-01	K-12		154788-0-01	J-45	
152822-0-01	H- 9		152923-0-01	J-66		153050-0-00	B-56		154789-0-01	J-44	
152823-0-01	H- 6		152924-0-01	H-47		153056-0-01	A-28		155336-0-01	G-48	
152827-0-01	H- 4		152925-1-01	J- 4		153056-0-02	A-28		155337-0-01	G-45- 2	
152828-0-01	H- 1		152926-0-01	J- 3		153057-0-01	E-22		155499-0-01	D-42	
152830-0-02	A-10		152929-0-01	J-12		153058-0-01	C- 1- 2		155500-0-01	D-50	
152831-0-00	A- 4		152933-0-01	K-44-10		153098-0-00	Z-28- 3		155501-0-01	C-37	
152832-0-02	A- 4- 1		152934-0-01	K-44- 1		153100-0-00	Z-28		155523-0-01	D- 5	
152833-0-01	A- 4- 2		152935-0-01	K-44-21		153102-0-01	Z-28- 2		155524-0-01	E-15	
152835-0-02	A-35		152936-0-01	K-44- 9		153104-0-01	G-41		155561-0-01	E-10-38	
152836-0-02	A-42		152937-0-01	K-44- 8		153138-0-01	K-19		155562-0-01	E-10-35	
152838-0-01	A-46		152938-0-01	K-44-19		153141-0-01	G-29		155563-0-01	E-21	
152839-0-01	A-43		152939-0-01	K-44-12		153195-0-01	G-45- 4		155564-0-01	E- 3	
152841-0-02	A- 8		152940-0-01	K-44-22		153208-0-02	J-14		155565-0-01	E- 2	
152842-0-02	A-47		152941-0-01	K-44-15		153219-0-01	J-27		155566-0-01	H-33	
152846-0-02	A-19		152945-0-01	K-43		153220-0-01	J-30		155567-0-01	E- 7	
152847-0-00	A-24		152948-0-01	M-13		153222-0-01	J-28		155568-0-01	E-10-11	
152848-0-01	A-20			M-50		153330-0-01	B- 7- 4		155569-0-01	E-10- 8	
152852-1-01	L-13		152949-0-01	M-14		153331-0-01	F-36		155570-0-01	E-10-43	
152857-0-01	L- 4		152950-0-01	M-14- 1		153332-0-01	G-45- 1		155571-0-01	J-11	
152858-0-01	L- 3		152951-0-01	M-14- 7		153343-0-01	G- 5		155573-0-01	E-10-49	
152859-0-01	L- 2		152952-0-01	M-14- 5		153344-0-01	G- 5		155575-0-01	E-10-42	
152860-0-01	L- 1		152953-0-01	M-45		153482-0-01	J-62		155576-0-01	E-10-33	
152861-1-01	L-17		152955-0-01	M- 1- 2		153484-0-01	H-54		155577-0-01	E-10-34	
152862-0-01	L-18		152956-0-01	M- 1- 3		153528-0-01	M-16		155698-0-01	E-10	
152863-0-01	L-26			M- 4		153529-0-01	M-17		155699-0-02	A-13	
152864-0-00	L-27		152958-0-01	M- 1		153530-0-01	M- 7		156061-0-01	E-10-39	
152865-0-01	L-20		152959-0-01	M- 1- 1		153531-0-01	M-60		156150-0-01	J-16	
152866-0-01	L- 7		152960-0-01	M- 6		153562-0-01	M-61		156161-0-01	E-10-27	
152867-0-00	A-26		152961-0-01	M-19		153574-2-01	Z-30		156170-0-01	E-10-29	
152868-0-00	A-25		152962-0-01	M- 5		153596-0-01	J-23		156334-0-02	Z-25	
152869-0-01	K- 2		152963-0-01	M-25		153597-0-01	J-22		402887-0-01	B-58	
152870-0-01	K- 3		152964-0-01	M-30		153598-0-01	J-25				
152872-0-01	K-29			M-31		153757-0-01	F-33		152901-0-01	J-20	
152873-0-01	K-28		152965-0-01	M-26		153762-1-01	F- 5		152906-1-01	J-21	
152874-0-01	H-17		152966-0-01	M-19- 1		153763-0-01	M-47				
152875-0-01	K-17		152967-0-01	M-19- 3		153827-0-01	E-17				
152876-0-01	K-15		152968-0-01	H-34		153828-0-01	H-52				
152877-0-01	K-20		152969-0-01	M-34		153834-0-01	E-20				
152878-0-01	K-21			M-53		153838-0-01	E- 1				
152879-1-01	K-22		152971-0-01	M-58		153867-1-01	D- 6				
152880-0-01	K-23		152972-0-01	M-56		153918-0-01	M-14- 6				
152881-0-01	K-11		152973-0-01	M-42		153919-0-01	M-14- 3				
152883-0-00	K-10			M-59		153920-0-01	M-57				
152884-0-01	K- 9		152974-0-01	M-36		153921-0-01	M-39				
152886-0-01	J- 5		152976-0-01	C-58		153922-0-01	M-24				
152887-0-01	J- 7		152977-0-01	C-57			M-28				

