

# DT4-B261

パーツブック

PARTS BOOK

TEILEKATALOG

LIVRE DES PIECES

LIBRO DE REFERENCIA DE PIEZAS

箱型1本針二重環縫ミシン

箱型2本針二重環縫ミシン

FLAT BED SINGLE NEEDLE DOUBLE CHAIN STITCHER

FLAT BED TWIN NEEDLE DOUBLE CHAIN STITCHER

EINNADEL-FLACHBETT-DOPPELKETTENSTICHMASCHINE

ZWEINADEL-FLACHBETT-DOPPELKETTENSTICHMASCHINE

MACHINE POINT DE CHAINETTE A PLATEAU - 1 AIGUILLE

MACHINE POINT DE CHAINETTE A PLATEAU - 2 AIGUILLES

RECUBRIDORA PLANA, UNA AGUJA

RECUBRIDORA PLANA, DOS AGUJAS

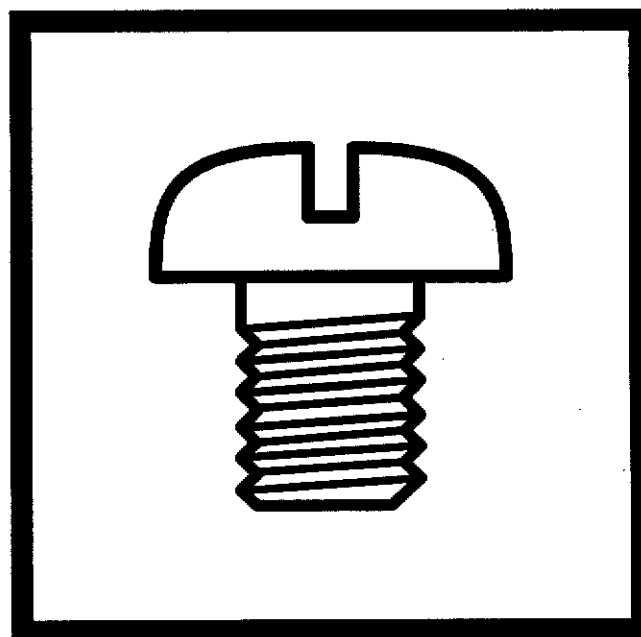

P261101

brother.

## パーツブックご利用に際して

1. この本は、この本の表紙(正誤表の挿入されている場合は正誤表)に記載されているものと同じプレートが取り付けられているミシンのためのものです。
2. この本は、1998年1月のデータに基づいて作成されたものです。
3. 部品は予告なしに設計変更される場合があります。
4. 組単位で補給する部品は、[ ] 破線で示しております。
5. 部品コード欄が※となっている場合は、仕様別部品一覧表(47ページ)でお調べ下さい。

## 目 次

A. 主体関係 .....	1
B. 上軸・針棒関係 .....	9
C. 針冷却関係 .....	15
D. ラッパー関係 .....	15
E. 押エ関係 .....	17
F. 送り関係 .....	23
G. プーラ装置関係 .....	27
H. 下軸関係 .....	31
J. ルーパー関係 .....	33
K. 給油潤滑関係 .....	35
L. 糸調子関係 .....	37
Z. 付属品関係 .....	43
仕様別部品一覧表 .....	47
索引 .....	50

## Notes for using this parts book

1. This book is applicable to sewing machines which have the same plate number as shown on the cover of this book (or correction sheet).
2. This book was prepared based on information available in January 1998.
3. Parts are subject to changes in design without prior notice.
4. Parts supplied as complete assemblies are circled by a dotted line [ ] .
5. If the symbol ※ is found in the "Parts No." column, refer to the different parts list on page 47.

## CONTENTS

A. Machine body .....	1
B. Upper shaft and needle bar mechanism .....	9
C. Needle cooler .....	15
D. Lapper mechanism .....	15
E. Presser foot mechanism .....	17
F. Feed mechanism .....	23
G. Puller device mechanism .....	27
H. Lower shaft mechanism .....	31
J. Looper mechanism .....	33
K. Lubrication .....	35
L. Thread tension .....	37
Z. Accessories .....	43
DIFFERENT PARTS LIST .....	47
INDEX .....	50

## Hinweise zur Verwendung dieser Teileliste

1. Dieses Buch bezieht sich auf die Nähmaschinen mit derselben Kennungsnummer wie auf diesem Buchumschlag (oder auf dem Korrekturblatt).
2. Dieses Buch basiert auf den Informationen vom Januar 1998.
3. Modelländerungen sind vorbehalten.
4. Die Teile, die als kompletter Satz geliefert werden, sind mit einer [ ] gestrichelten Linie umrandet.
5. Dieses Zeichen ※ in der Spalte "Parts No. (Teil-nummer)" verweist auf die Gesonderte Stückliste auf Seite 47.

## INHALTSVERZEICHNIS

A. Maschinengehäuse .....	1
B. Obere Welle und Nadelstangenvorrichtung .....	9
C. Nadelkühlungsvorrichtung ...	15
D. Falz-mechanismus .....	15
E. Stoffdrückerfuß .....	17
F. Transportvorrichtung .....	23
G. Ziehvorrichtung .....	27
H. Untere Welle .....	31
J. Greifer .....	33
K. Schmierung .....	35
L. Fadenspannung .....	37
Z. Zubehör .....	43
ZUBEHÖRLISTE .....	47
VERZEICHNIS .....	50

## Notes sur l'utilisation de ce manuel de pièces détachées

1. Ce manuel est destiné aux machines à coudre ayant le même numéro de plaque montré sur la couverture de ce manuel (ou sur la feuille de corrections).
2. Ce manuel a été fait d'après les renseignements valables au mois de Janvier 1998.
3. Les pièces peuvent être sujettes à des modifications sans préavis.
4. Les pièces fournies en tant qu'assemblages complets sont encadrées avec un trait pointillé [-----].
5. Si le symbole ※ se trouve dans la colonne "Parts No. (N° de pièce)" veuillez la vous référer à la liste de pièces annexe page 47.

### TABLE DES MATIERES

A. Corps de la machine .....	1
B. Mécanisme de arbre supérieur et barra à aiguille .....	9
C. Mécanisme du refroidisseur d'aiguille .....	15
D. Mécanisme à rabat .....	15
E. Mécanisme de pied presseur ...	17
F. Mécanisme de l'entraînement .	23
G. Mécanisme due puller .....	27
H. Mécanisme de l'arbre inférieur	31
J. Mécanisme des griffes .....	33
K. Lubrification .....	35
L. Tension du fil .....	37
Z. Accessoires .....	43
LISTE DES PIECES ACCESSOIRES .....	47
INDEX .....	50

## Notas para usar este Manual de Piezas

1. Este libro sirve para todas las máquinas de coser que llevan la misma placa de identificación que la que se puede ver en la tapa de este libro (o en la hoja de erratas).
2. Este libro ha sido compilado basándose en los datos de que se disponía en enero 1998.
3. Las piezas quedan sujetas a cambios de diseño sin aviso previo.
4. Las piezas suministradas como conjuntos completos se enmarcan con una línea punteada [-----].
5. De haber un símbolo ※ junto al "Parts No. (Número de Pieza)", habrá que mirar la lista de piezas separada de la página 47.

### INDICE

A. Cuerpo de la máquina .....	1
B. Mecanismo del eje superior y la barra de aguaja .....	9
C. Mecanismo del enfriador de aguja .....	15
D. Mecanismo de solapado .....	15
E. Mecanismo de la prensa tela ...	17
F. Mecanismo de la alimentación .	23
G. Mecanismo del dispositivo de arrastre .....	27
H. Mecanismo del eje inferior ....	31
J. Mecanismo del presilladora ...	33
K. Lubricación .....	35
L. Tensión del hilo .....	37
Z. Accesorios .....	43
LISTA DE PIEZAS ACCESORIAS .....	47
INDICE .....	50

A. 主体関係 / Machine body / Maschinengehäuse / Corps de la machine / Cuerpo de la máquina

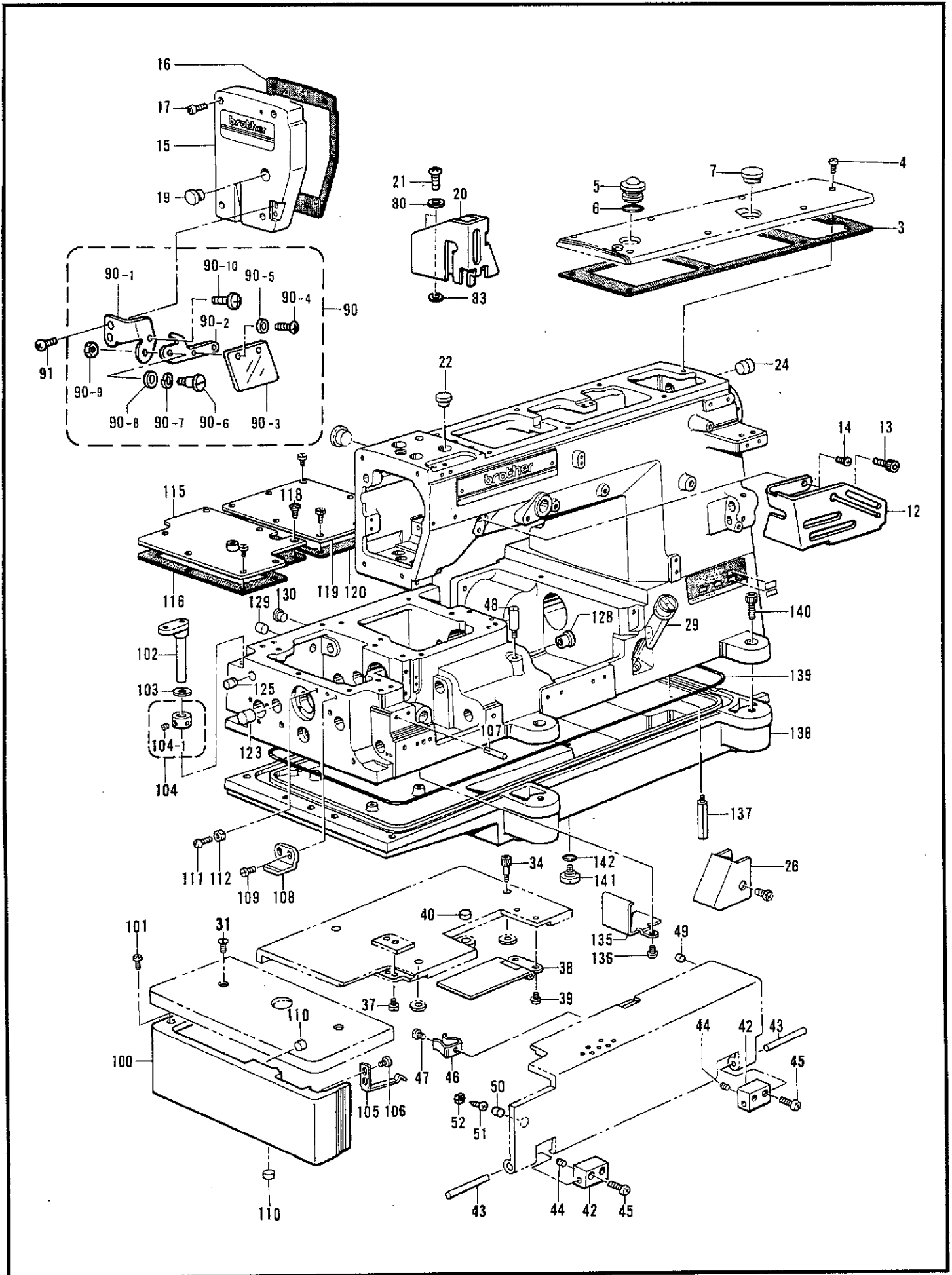

A. 主体関係 / Machine body / Maschinengehäuse / Corps de la machine / Cuerpo de la máquina

REF.NO.	CODE	Q'TY	ヒンメイ	NAME OF PARTS	RM
3	S08628000	1	ウワフタパツキン	TOP COVER PACKING	
4	062681012	7	ナベコ437-40X10	SCREW, PAN SM4.37-40X10	
5	S02606000	1	ユリヨウケイマド	OIL GAUGE WINDOW	
6	081014670	1	OリングPW14	O RING, PW14	
7	159150009	1	ゴムセン20.5	RUBBER CAP, 20.5	
12	S40532001	1	ハライトクリカバー	NEEDLE THREAD TAKE-UP COVER	
13	018060822	1	アナボルト6X8	BOLT, SOCKET M6X8	
14	S10774001	1	ナベコ437-40X7	SCREW, PAN M4.37-40X7	
15	S28810051	1	メンイタ	FACE PLATE	
16	S08631000	1	メンイタパツキン	FACE PLATE PACKING	
17	062681612	4	ナベコ437-40X16	SCREW, PAN SM4.37-40X16	
19	117934009	1	ゴムセン13.5	RUBBER CAP, 13.5	
20	S28809201	1	ハリボウテンピンカバー	NEEDLE BAR TAKE-UP COVER	
21	062681012	2	ナベコ437-40X10	SCREW, PAN SM4.37-40X10	
22	104449009	1	ゴムセン15.5	RUBBER CAP, 15.5	
24	S00313009	1	ゴムセン16.8	RUBBER CAP, 16.8	
26	S08633101	1	シタイトカバー	BOBBIN THREAD COVER	
29	148084001	1	オイルゲージマド	OIL GAUGE WINDOW	
31	100032004	2	サラネジ4.37	SCREW, FLAT SM4.37	
34	S09123101	3	アナボルト4.37X15	BOLT, SOCKET M4.37X15	
37	123185001	2	マルヒラネジ3.57X4.5	SCREW, OVAL M3.57X4.5	
38	S08642001	1	シタイトテンピンカバークミ	LOOPER THREAD TAKE-UP COVER ASSY	
39	123185001	2	マルヒラネジ3.57X4.5	SCREW, OVAL M3.57X4.5	
40	S08646100	1	マグネット	MAGNET	
42	S08651001	2	マエカバーササエ	FRONT COVER SUPPORT	
43	S08652000	2	マエカバーササエジク	FRONT COVER SUPPORT SHAFT	
44	153675001	2	アナトメネジ4.37	SET SCREW, SOCKET SM4.37	
45	060681612	4	バインド437-40X16	SCREW, BIND SM4.37-40X16	
46	114985001	1	ベツトカバートメバネ	SPRING, PLATE	
47	062680612	1	ナベコ4.37-40X6	SCREW, PAN SM4.37-40X6	
48	S08653001	1	バネウケネジ	SCREW	
49	142274009	2	ゴムセン4.2	RUBBER CAP, 4.2	
50	146586009	1	ゴムセン11	RUBBER CAP, 11	
51	062681412	1	ナベコ437-40X14	SCREW, PAN SM4.37-40X14	
52	105234003	1	ナツト4.37	NUT, SM4.37	
80	100645003	2	ザガネ	WASHER	
83	025680133	2	ヒラザガネシヨウ4.37	WASHER, PLAIN S 4.37	
90	S28802001	1	アイガードクミ	EYE GUARD ASSY	
90-1	S28803001	1	アイガードドダイ	EYE GUARD BASE	
90-2	S28804001	1	アイガードトリツケイタ	EYE GUARD SETTING PLATE	
90-3	S00075000	1	アイガード	EYE GUARD	
90-4	062660512	2	ナベコネジ318-40X5	SCREW, PAN SM3.18-40X5	
90-5	025030232	2	ヒラザガネチユウ3	WASHER, PLAIN M 3	
90-6	S07317001	1	ダンネジ3.57	SHOULDER SCREW, SM3.57	
90-7	028050246	1	バネザガネ2-5	WASHER, SPRING 2-5	
90-8	025050232	1	ヒラザガネチユウ5	WASHER, PLAIN M 5	
90-9	106129001	1	ナツト3.57	NUT, SM3.57	
90-10	060670512	1	バインド357-40X5	SCREW, BIND SM3.57-40X5	
91	060680712	2	バインド437-40X7	SCREW, BIND SM4.37-40X7	
100	S08665001	1	ヨコカバー	SIDE COVER	
101	062680812	2	ナベコ437-40X8	SCREW, PAN SM4.37-40X8	
102	S00017001	1	クロスプレートササエジク	CLOTH PLATE SUPPORT SHAFT	
103	141183000	1	クロスプレートシート	CLOTH PLATE SHEET	
104	183893001	1	セツトカラークミ	SET SCREW COLLAR ASSY	
104-1	101706001	2	トメネジ6.35	SET SCREW, SM6.35	
105	S08667001	1	ヨコカバートメイタバネ	PLATE SPRING	
106	060680712	2	バインド437-40X7	SCREW, BIND SM4.37-40X7	

A. 主体関係 / Machine body / Maschinengehäuse / Corps de la machine / Cuerpo de la máquina

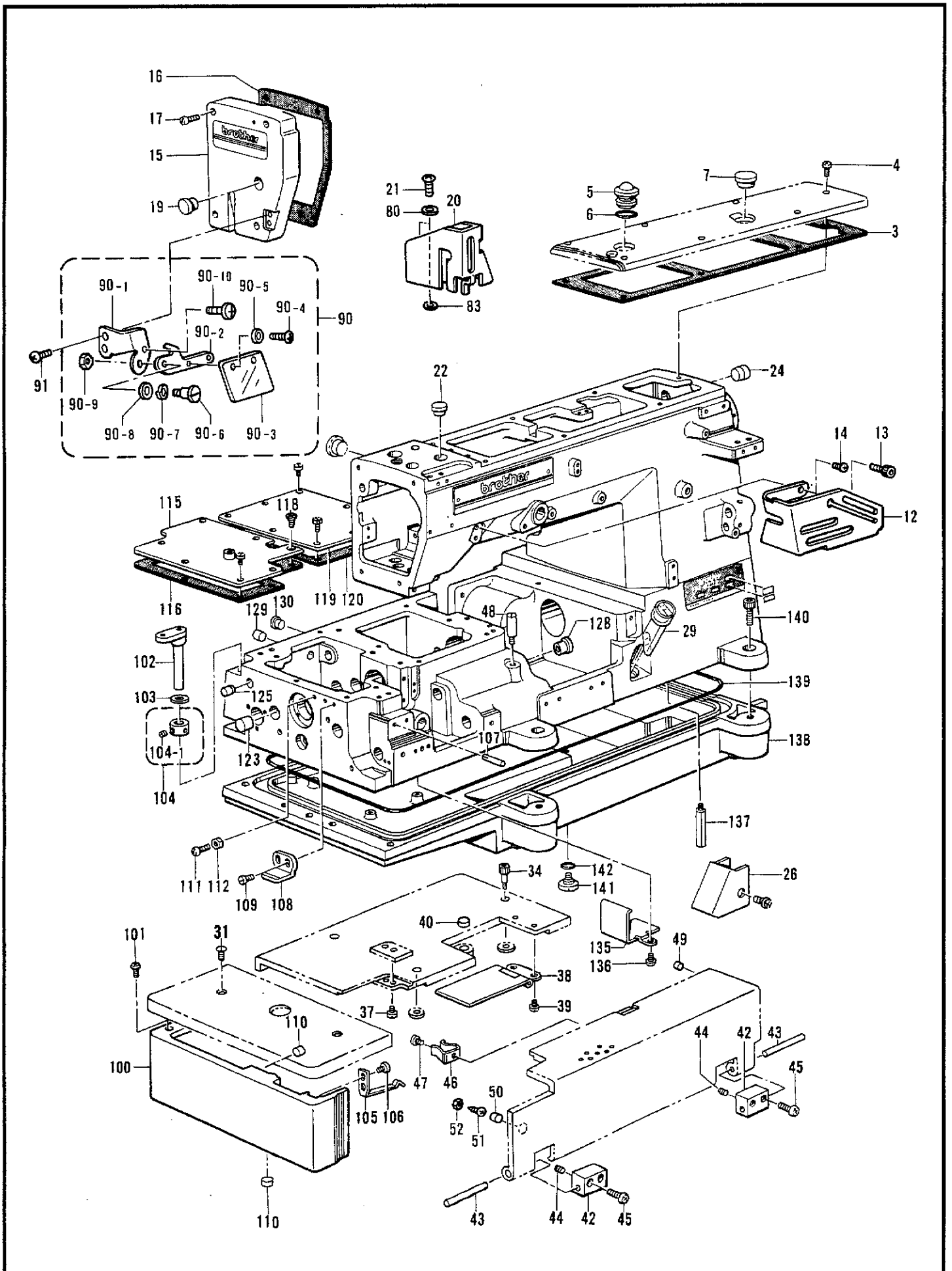

118-261-052

A . 主体関係 / Machine body / Maschinengehäuse / Corps de la machine / Cuerpo de la máquina

REF.NO.	CODE	Q'TY	ヒンメイ	NAME OF PARTS	RM
107	140063001	1	ミソツキピン	DOWEL PIN	
108	S08668001	1	ヨコカバーガイド	SIDE COVER GUIDE	
109	107407003	2	シメネジ4.37	SCREW, SM4.37	
110	146586009	2	ゴムセン11	RUBBER CAP, 11	
111	062681012	1	ナベコ437-40X10	SCREW, PAN SM4.37-40X10	
112	105234003	1	ナツト4.37	NUT, SM4.37	
115	S40533001	1	オクリキコウカバー	FEED MECHANISM COVER	
116	S08670000	1	オクリキコウカバーパツキン	FEED MECHANISM COVER PACKING	
118	151267001	1	サラネジ4.37	SCREW, FLAT SM4.37	
119	S08671101	1	ベッドウワカバー	BED UPPER COVER	
120	S08672000	1	ベッドウワカバパツキン	BED UPPER COVER PACKING	
123	S00313009	1	ゴムセン16.8	RUBBER CAP, 16.8	
125	146315009	1	ゴムセン10.7	RUBBER CAP, 10.7	
128	S08673000	1	ゴムセン14	RUBBER CAP, 14	
129	146586009	1	ゴムセン11	RUBBER CAP, 11	
130	104450109	1	ゴムセン8	RUBBER CAP, 8	
135	146457001	1	シキリイタ	OIL STOPPER PLATE	
136	062670612	2	ナベコ357-40X6	SCREW, PAN SM3.57-40X6	
137	151059001	4	ホンタイシチユウ	MACHINE BODY LEG	
138	S08674000	1	アブラウケ	OIL RESERVOIR	
139	S08675000	1	Oリング	O RING	
140	018081622	5	アナボルト8X16	BOLT, SOCKET M8X16	
141	110641002	1	ダンネジ9.52	STUD SCREW, SM9.52	
142	109203001	1	Oリング	O RING	



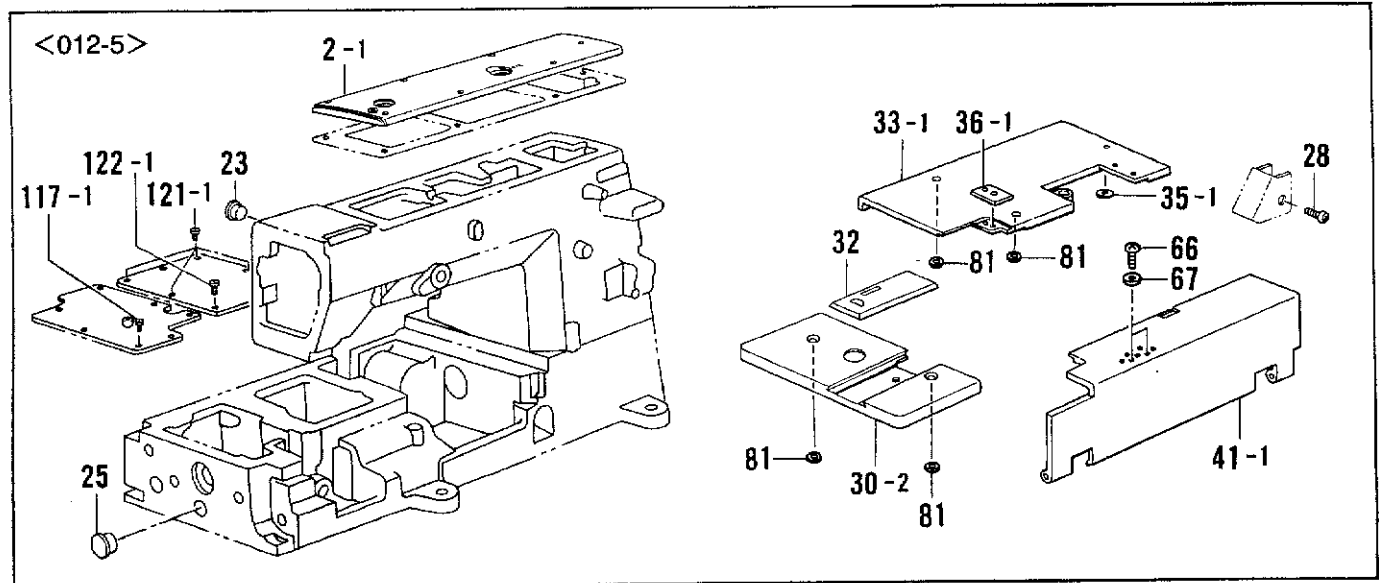
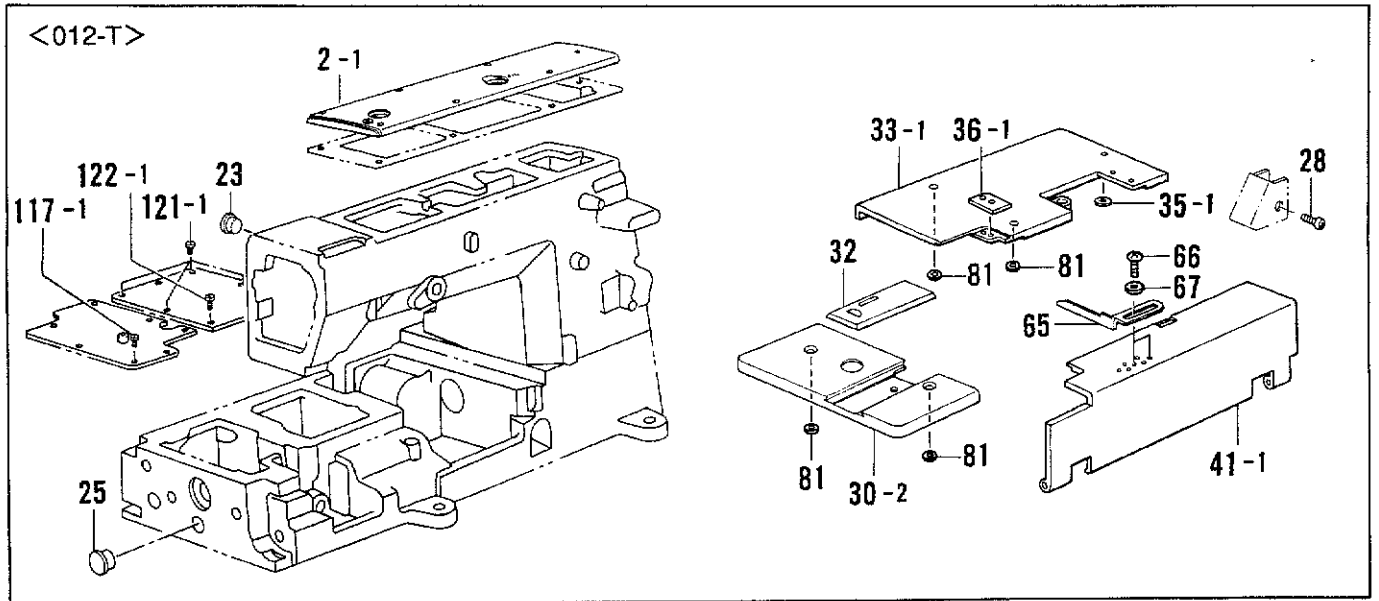
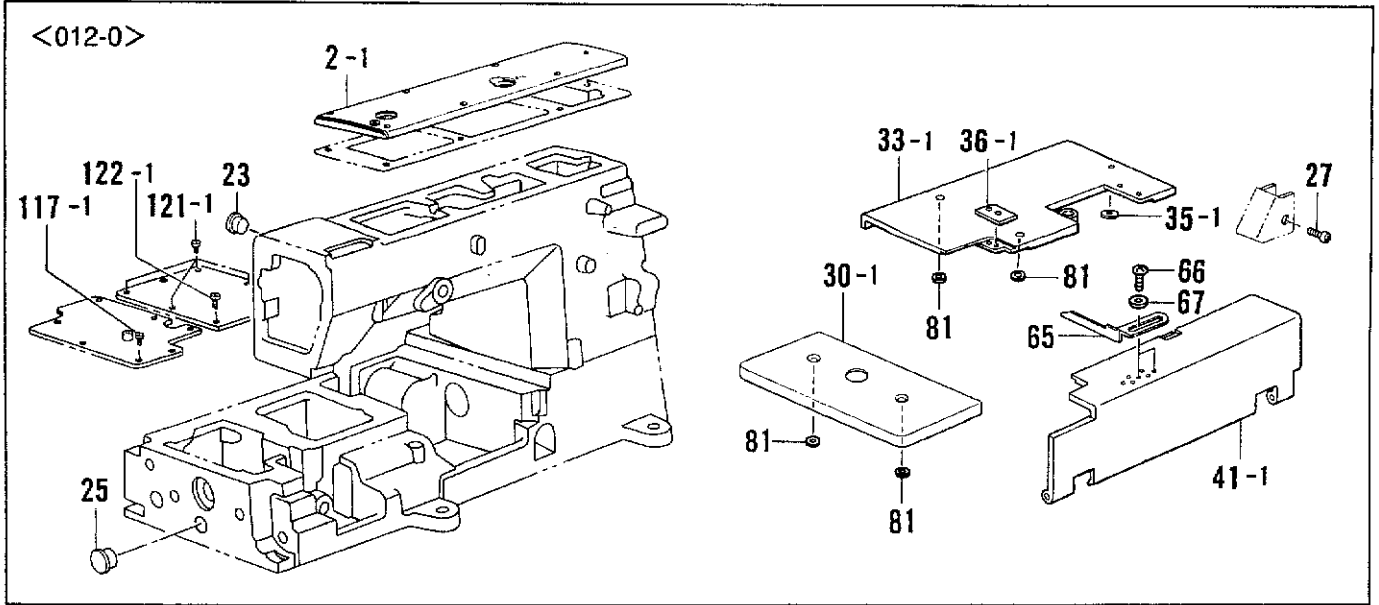

A. 主体関係 / Machine body / Maschinengehäuse / Corps de la machine / Cuerpo de la máquina

REF.NO.	CODE	Q'TY	ヒンメイ	NAME OF PARTS	RM
			<b>&lt;012-0&gt;</b>	<b>&lt;012-0&gt;</b>	
2-1	S08627001	1	ウワフタ	TOP COVER	
23	108520009	1	ゴムセン19.8	RUBBER CAP, 19.8	
25	158437009	1	ゴムセン10	RUBBER CAP, 10	
27	062680812	1	ナベコ437-40X8	SCREW, PAN SM4.37-40X8	
30-1	S08634151	1	クロスプレートL	CLOTH PLATE (L)	
33-1	S08637001	1	クロスプレートR	CLOTH PLATE (R)	
35-1	S08639000	1	クロスプレートパツキン	CLOTH PLATE PACKING	
36-1	S08640001	1	クロスプレートホジヨイタ	SUB-CLOTH PLATE	
41-1	S08647101	1	マエカパー	FRONT COVER	
65	S40535001	1	ヌノガイド	CLOTH GUIDE	
66	062710812	2	ナベコ476-32X8	SCREW, PAN SM4.76-32X8	
67	146354001	2	ザガネ	WASHER, PLAIN 5	
81	S34200000	4	ソレノイドクツシヨン	SOLENOID CUSHION	
117-1	107407003	6	シメネジ4.37	SCREW, SM4.37	
121-1	107407003	4	シメネジ4.37	SCREW, SM4.37	
122-1	117516001	2	ボルト4.37	BOLT, M4.37	
			<b>&lt;012-T&gt;</b>	<b>&lt;012-T&gt;</b>	
2-1	S08627001	1	ウワフタ	TOP COVER	
23	108520009	1	ゴムセン19.8	RUBBER CAP, 19.8	
25	158437009	1	ゴムセン10	RUBBER CAP, 10	
28	062681012	1	ナベコ437-40X10	SCREW, PAN SM4.37-40X10	
30-2	S40960051	1	クロスプレートL	CLOTH PLATE (L)	
32	S40961001	1	スベリイタ	SLIDER PLATE	
33-1	S08637001	1	クロスプレートR	CLOTH PLATE (R)	
35-1	S08639000	1	クロスプレートパツキン	CLOTH PLATE PACKING	
36-1	S08640001	1	クロスプレートホジヨイタ	SUB-CLOTH PLATE	
41-1	S08647101	1	マエカパー	FRONT COVER	
65	S40535001	1	ヌノガイド	CLOTH GUIDE	
66	062710812	2	ナベコ476-32X8	SCREW, PAN SM4.76-32X8	
67	146354001	2	ザガネ	WASHER, PLAIN 5	
81	S34200000	4	ソレノイドクツシヨン	SOLENOID CUSHION	
117-1	107407003	6	シメネジ4.37	SCREW, SM4.37	
121-1	107407003	4	シメネジ4.37	SCREW, SM4.37	
122-1	117516001	2	ボルト4.37	BOLT, M4.37	
			<b>&lt;012-5&gt;</b>	<b>&lt;012-5&gt;</b>	
2-1	S08627001	1	ウワフタ	TOP COVER	
23	108520009	1	ゴムセン19.8	RUBBER CAP, 19.8	
25	158437009	1	ゴムセン10	RUBBER CAP, 10	
28	062681012	1	ナベコ437-40X10	SCREW, PAN SM4.37-40X10	
30-2	S40960051	1	クロスプレートL	CLOTH PLATE (L)	
32	S40961001	1	スベリイタ	SLIDER PLATE	
33-1	S08637001	1	クロスプレートR	CLOTH PLATE (R)	
35-1	S08639000	1	クロスプレートパツキン	CLOTH PLATE PACKING	
36-1	S08640001	1	クロスプレートホジヨイタ	SUB-CLOTH PLATE	
41-1	S08647101	1	マエカパー	FRONT COVER	
66	062710812	2	ナベコ476-32X8	SCREW, PAN SM4.76-32X8	
67	146354001	2	ザガネ	WASHER, PLAIN 5	
81	S34200000	4	ソレノイドクツシヨン	SOLENOID CUSHION	
117-1	107407003	6	シメネジ4.37	SCREW, SM4.37	
121-1	107407003	4	シメネジ4.37	SCREW, SM4.37	
122-1	117516001	2	ボルト4.37	BOLT, M4.37	

A. 主体関係 / Machine body / Maschinengehäuse / Corps de la machine / Cuerpo de la máquina

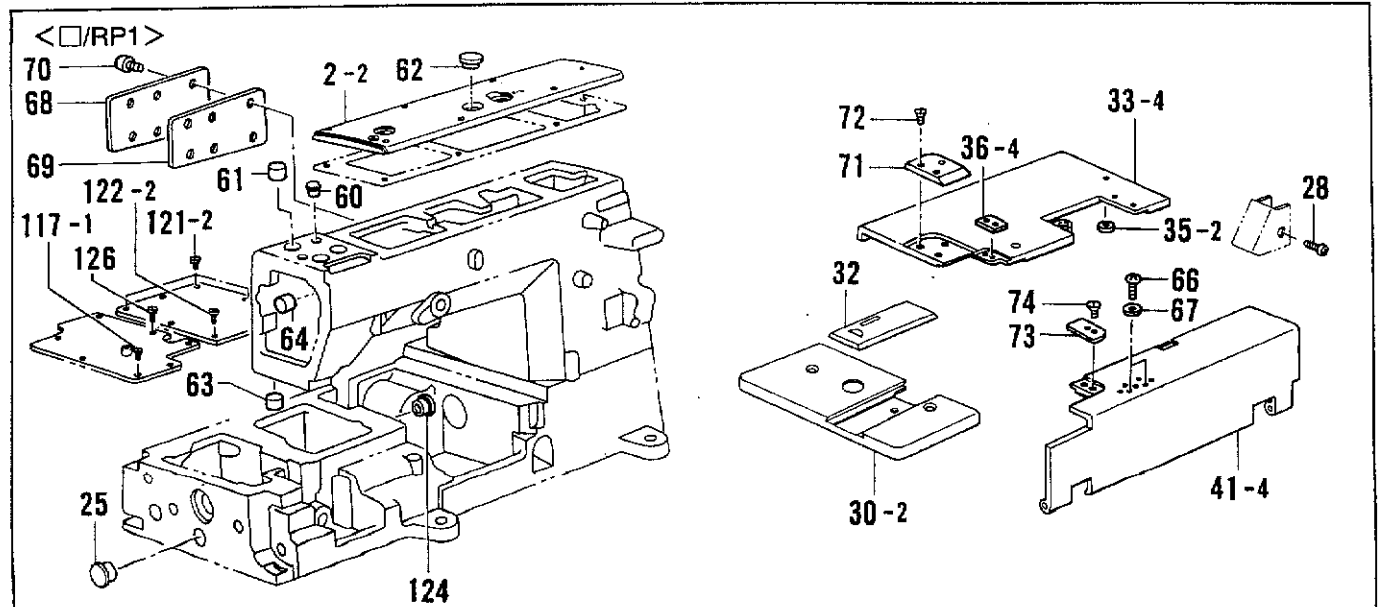
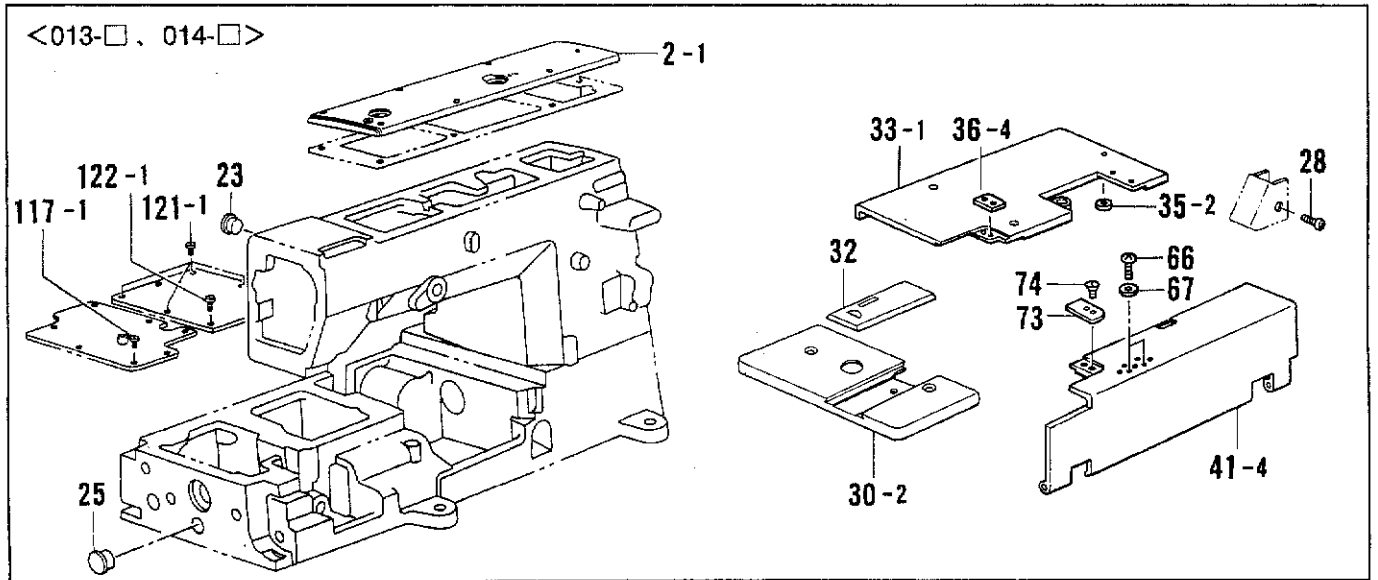
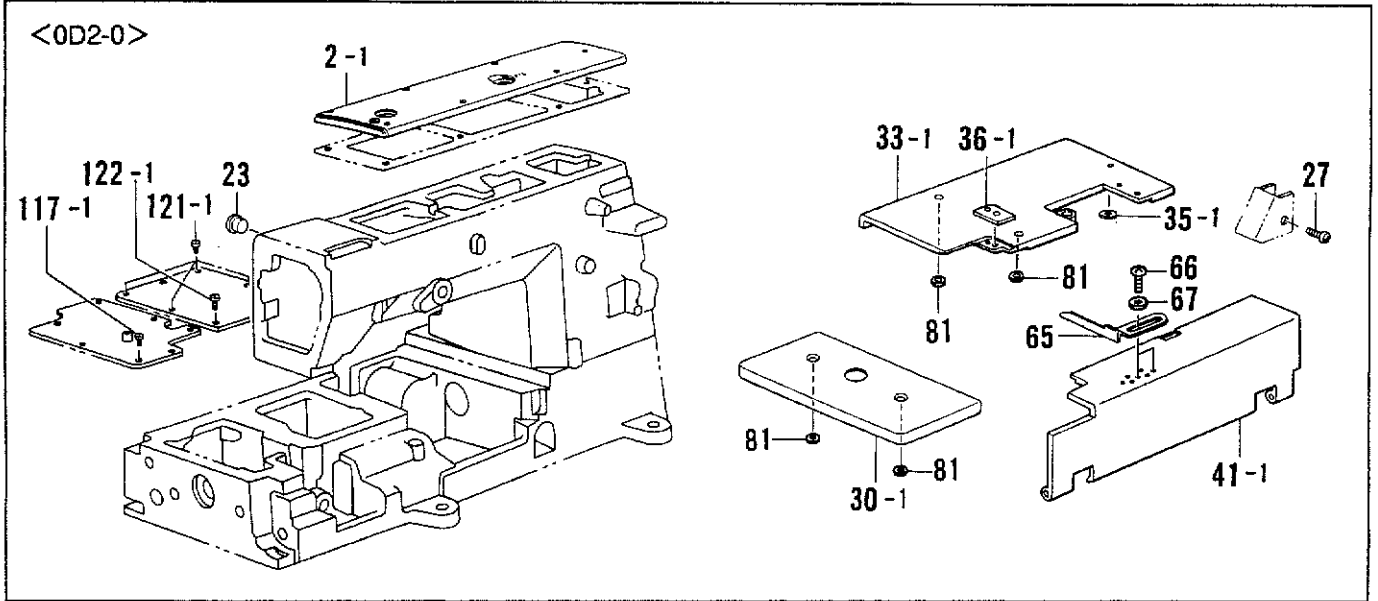

A. 主体関係 / Machine body / Maschinengehäuse / Corps de la machine / Cuerpo de la máquina

REF.NO.	CODE	Q'TY	ヒンメイ	NAME OF PARTS	RM
			<0D2-0>	<0D2-0>	
2-1	S08627001	1	ウワフタ	TOP COVER	
23	108520009	1	ゴムセン19.8	RUBBER CAP, 19.8	
27	062680812	1	ナベコ437-40X8	SCREW, PAN SM4.37-40X8	
30-1	S08634151	1	クロスプレートL	CLOTH PLATE (L)	
33-1	S08637001	1	クロスプレートR	CLOTH PLATE (R)	
35-1	S08639000	1	クロスプレートパツキン	CLOTH PLATE PACKING	
36-1	S08640001	1	クロスプレートホジヨイタ	SUB-CLOTH PLATE	
41-1	S08647101	1	マエカバー	FRONT COVER	
65	S40535001	1	ヌノガイド	CLOTH GUIDE	
66	062710812	2	ナベコ476-32X8	SCREW, PAN SM4.76-32X8	
67	146354001	2	ザガネ	WASHER, PLAIN 5	
81	S34200000	4	ソレノイドクツシヨン	SOLENOID CUSHION	
117-1	107407003	6	シメネジ4.37	SCREW, SM4.37	
121-1	107407003	4	シメネジ4.37	SCREW, SM4.37	
122-1	117516001	2	ボルト4.37	BOLT, M4.37	
			<013-□,014-□>	<013-□,014-□>	
2-1	S08627001	1	ウワフタ	TOP COVER	
23	108520009	1	ゴムセン19.8	RUBBER CAP, 19.8	
25	158437009	1	ゴムセン10	RUBBER CAP, 10	
28	062681012	1	ナベコ437-40X10	SCREW, PAN SM4.37-40X10	
30-2	S40960051	1	クロスプレートL	CLOTH PLATE (L)	
32	S40961001	1	スベリイタ	SLIDER PLATE	
33-1	S08637001	1	クロスプレートR	CLOTH PLATE (R)	
35-2	025080132	1	ヒラザガネシヨウ8	WASHER, PLAIN S 8	
36-4	S44876001	1	クロスプレートホジヨイタ	SUB-CLOTH PLATE	
41-4	S44878001	1	マエカバー	FRONT COVER	
66	062710812	2	ナベコ476-32X8	SCREW, PAN SM4.76-32X8	
67	146354001	2	ザガネ	WASHER, PLAIN 5	
73	S44879001	1	マエカバーホジヨイタ	SUB-FRONT COVER	
74	108960002	2	サラネジ3.57	SCREW, FLAT SM3.57	
117-1	107407003	6	シメネジ4.37	SCREW, SM4.37	
121-1	107407003	4	シメネジ4.37	SCREW, SM4.37	
122-1	117516001	2	ボルト4.37	BOLT, M4.37	
			<□/RP1>	<□/RP1>	
2-2	S12703001	1	ウワフタ	TOP COVER	
25	158437009	1	ゴムセン10	RUBBER CAP, 10	
28	062681012	1	ナベコ437-40X10	SCREW, PAN SM4.37-40X10	
30-2	S40960051	1	クロスプレートL	CLOTH PLATE (L)	
32	S40961001	1	スベリイタ	SLIDER PLATE	
33-4	S44875001	1	クロスプレートR	CLOTH PLATE (R)	
35-2	025080132	1	ヒラザガネシヨウ8	WASHER, PLAIN S 8	
36-4	S44876001	1	クロスプレートホジヨイタ	SUB-CLOTH PLATE	
41-4	S44878001	1	マエカバー	FRONT COVER	
60	104450109	2	ゴムセン8	RUBBER CAP, 8	
61	154841009	1	ゴムセン16.8	RUBBER CAP, 16.8	
62	159150009	1	ゴムセン20.5	RUBBER CAP, 20.5	
63	154841009	1	ゴムセン16.8	RUBBER CAP, 16.8	
64	156887001	1	ゴムセン17.5	RUBBER CAP, 17.5	
66	062710812	2	ナベコ476-32X8	SCREW, PAN SM4.76-32X8	
67	146354001	2	ザガネ	WASHER, PLAIN 5	
68	S28007001	1	ガワイタ	REAR COVER	
69	S28008000	1	ガワイタパツキン	REAR COVER PACKING	
70	062680812	6	ナベコ437-40X8	SCREW, PAN SM4.37-40X8	
71	S44877001	1	スベリイタ	SLIDER PLATE	
72	108960002	3	サラネジ3.57	SCREW, FLAT SM3.57	
73	S44879001	1	マエカバーホジヨイタ	SUB-FRONT COVER	
74	108960002	2	サラネジ3.57	SCREW, FLAT SM3.57	
117-2	107407003	5	シメネジ4.37	SCREW, SM4.37	
121-2	107407003	3	シメネジ4.37	SCREW, SM4.37	
122-2	117516001	3	ボルト4.37	BOLT, M4.37	
124	S08673000	1	ゴムセン14	RUBBER CAP, 14	
126	117516001	1	ボルト4.37	BOLT, M4.37	

B. 上軸・針棒関係 / Upper shaft and needle bar mechanism / Obere Welle und Nadelstangenvorrichtung / Mécanisme de arbre supérieur et barra à aiguille / Mecanismo del eje superior y la barra de aguja

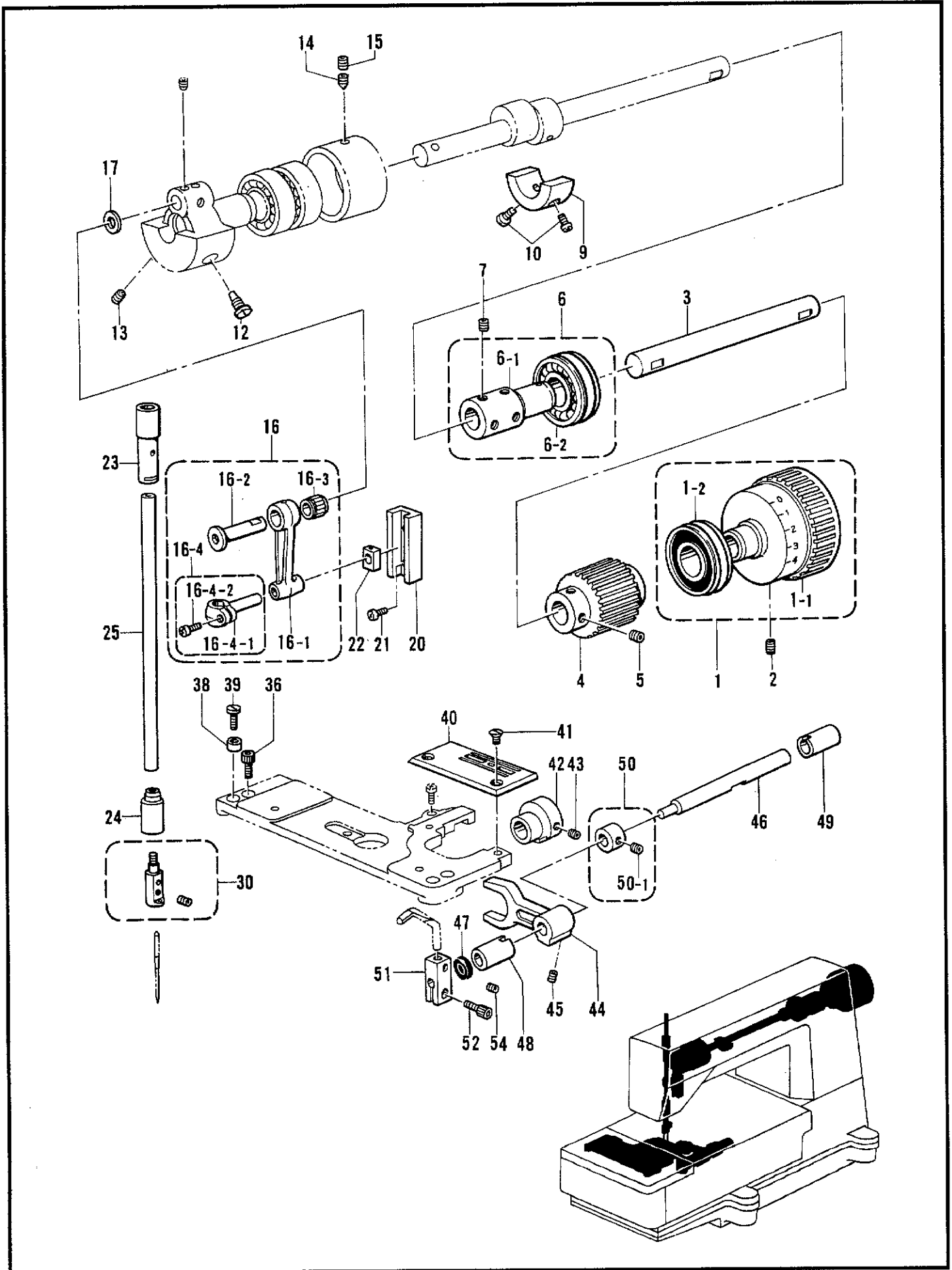

B. 上軸・針棒関係 / Upper shaft and needle bar mechanism / Obere Welle und Nadelstangenvorrichtung / Mécanisme de arbre supérieur et barra à aiguille / Mecanismo del eje superior y la barra de aguaja

REF.NO.	CODE	Q'TY	ヒンメイ	NAME OF PARTS	RM
1	S28957001	1	プーリクミ	PULLEY ASSY	
1-1	S28958001	1	プーリ	PULLEY	
1-2	S14621001	1	タマジクウケ6204LLB	BALL BEARING, 6204LLB	
2	014770622	2	アナトメネジ6.35クボミ	SET SCREW, SOCKET (CP) SM6.35	
3	S08682001	1	ウワジクR	UPPER SHAFT, R	
4	S08683000	1	タイミングプーリU	TIMING PULLEY, U	
5	014770622	4	アナトメネジ6.35クボミ	SET SCREW, SOCKET (CP) SM6.35	
6	S08684101	1	ツギテLクミ	JOINT ASSY, L	
6-1	S08685001	1	ツギテL	JOINT, L	
6-2	S08686101	1	タマジクウケ6204LU	BALL BEARING, 6204LU	
7	014770622	4	アナトメネジ6.35クボミ	SET SCREW, SOCKET (CP) SM6.35	
9	S08688051	1	ウエイト	WEIGHT	
10	062711012	2	ナベコ476-32X10	SCREW, PAN SM4.76-32X10	
12	104464001	1	シメネジ7.14	SCREW, SM7.14	
13	014770622	1	アナトメネジ6.35クボミ	SET SCREW, SOCKET (CP) SM6.35	
14	118853001	1	アナトメネジ5.95	SET SCREW, SOCKET SM5.95	
15	014760622	1	アナトメネジ5.95	SET SCREW, SOCKET SM5.95	
16	S08692101	1	ハリボウレンカンクミ	THREAD TAKE-UP LEVER ASSY	
16-1	S08693001	1	ハリボウレンカン	NEEDLE BAR CONNECTING ROD	
16-2	S08694001	1	ハリボウレンカンジク	THREAD TAKE-UP LEVER SHAFT	
16-3	S09120001	1	ニードルジクウケ	NEEDLE ROLLER BEARING	
16-4	S30086001	1	ハリボウダキクミ	NEEDLE BAR CLAMP ASSY	
16-4-1	S08695001	1	ハリボウダキ	NEEDLE BAR CLAMP	
16-4-2	100064005	1	シメネジ3.57	SCREW, SM3.57	
17	107153001	1	ザガネ	WASHER	
20	145688000	1	ハリボウアンナイ	NEEDLE BAR GUIDE	
21	062670612	2	ナベコ357-40X6	SCREW, PAN SM3.57-40X6	
22	102630001	1	ハリボウアンナイカクコマ	NEEDLE BAR GUIDE SLIDE BLOCK	
23	S08696000	1	ハリボウメタルU	NEEDLE BAR BUSH, U	
24	S08697000	1	ハリボウメタルD	NEEDLE BAR BUSH, D	
25	S08698001	1	ハリボウ	NEEDLE BAR	
30	※	1	ハリドメ1クミ	NEEDLE CLAMP ASSY	
36	018681022	2	アナボルト4.37X10	BOLT, SOCKET SM4.37X10	
38	S09124001	2	ハリイタササエイタカラー	COLLER	
39	S13385001	2	シメネジ3.57X10	SCREW, SM3.57X10	
40	※	1	ハリイタ	NEEDLE PLATE	
41	S09121001	2	マルサラネジ3.57X6	SCREW, FLAT M3.57X6	
42	S08750001	1	ハリウケBヘンシンリン	NEEDLE GUARD REAR ECCENTRIC WHEEL	
43	014680622	2	アナトメネジ4.37クボミ	SET SCREW, SOCKET (CP) SM4.37	
44	S08751001	1	ハリウケBレバー	NEEDLE GUARD REAR LEVER	
45	014680622	2	アナトメネジ4.37クボミ	SET SCREW, SOCKET (CP) SM4.37	
46	S08752001	1	ハリウケBジク	NEEDLE GUARD REAR SHAFT	
47	155539000	1	ダストシール	DUST SEAL	
48	S08753000	1	ハリウケBジクメタルL	KNIFE DRIVING SHAFT BUSH (L)	
49	S08754000	1	ハリウケBジクメタルR	KNIFE DRIVING SHAFT BUSH (R)	
50	S03704002	1	セツトカラークミ	SET SCREW COLLAR ASSY	
50-1	014770622	2	アナトメネジ6.35クボミ	SET SCREW, SOCKET (CP) SM6.35	
51	S08755101	1	ハリウケBトリツケダイ	NEEDLE GUARD BACK SET BRACKET	
52	018681022	1	アナボルト4.37X10	BOLT, SOCKET SM4.37X10	
54	014680422	1	アナトメネジ4.37クボミ	SET SCREW, SOCKET (CP) SM4.37	

B. 上軸・針棒関係 / Upper shaft and needle bar mechanism / Obere Welle und Nadelstangenvorrichtung / Mécanisme de arbre supérieur et barra à aiguille / Mecanismo del eje superior y la barra de aguja

<012-0, 0D2-0>

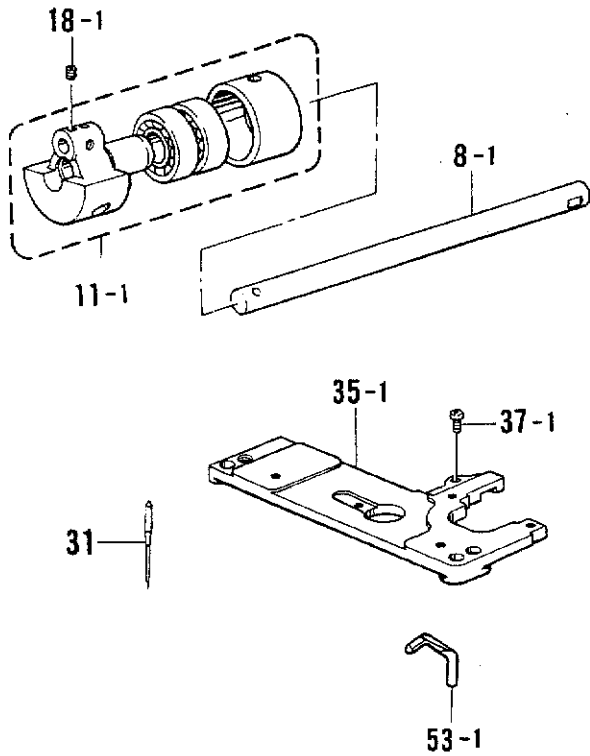

<012-T>

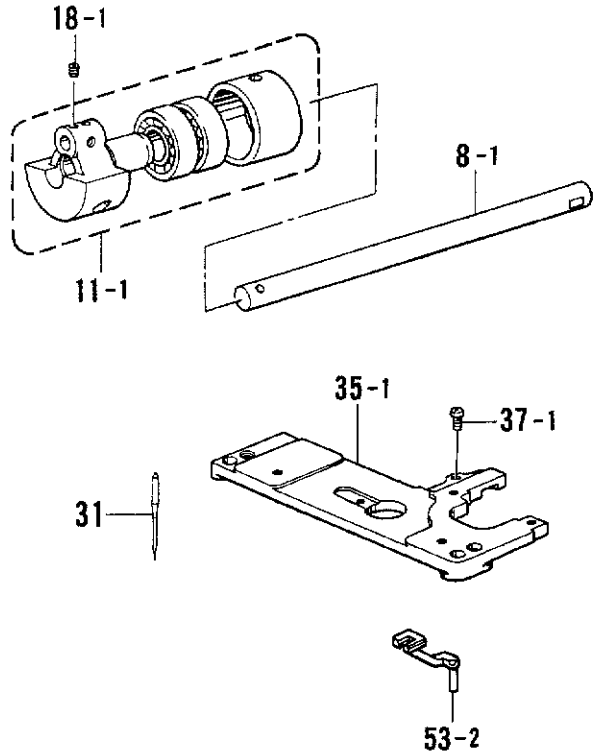

<012-5>

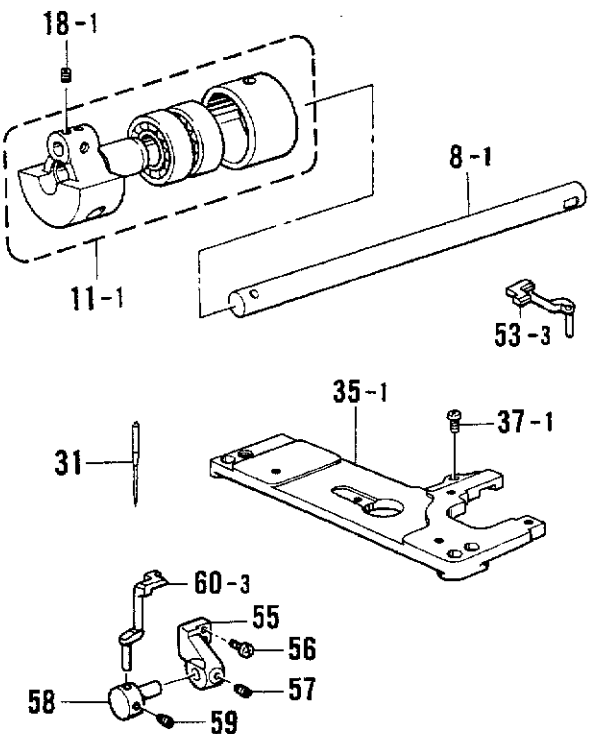

<013-□, 014-□>

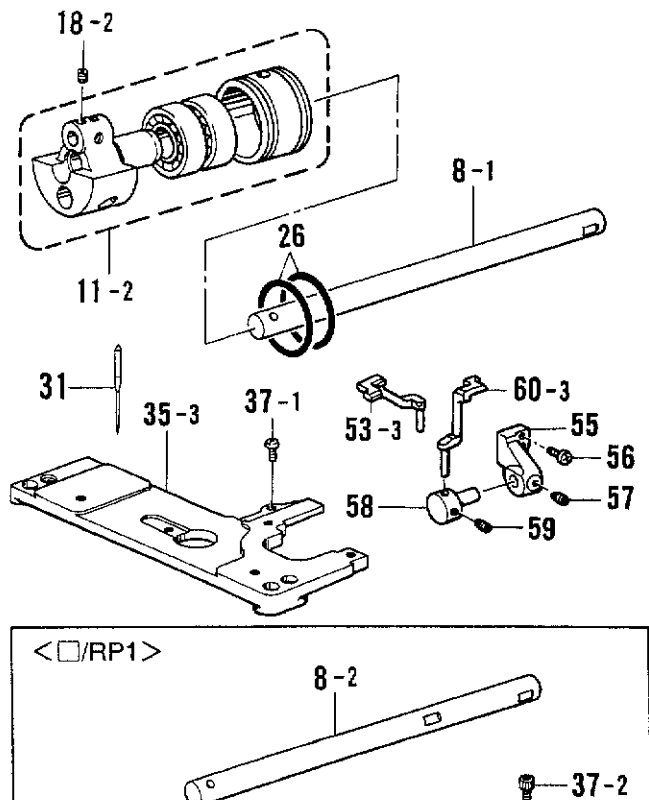

B. 上軸・針棒関係 / Upper shaft and needle bar mechanism / Obere Welle und Nadelstangenvorrichtung / Mécanisme de arbre supérieur et barra à aiguille / Mecanismo del eje superior y la barra de aquaja

REF.NO.	CODE	Q'TY	ヒンメイ	NAME OF PARTS	RM
			<012-0,0D2-0>	<012-0,0D2-0>	
8-1	S08687001	1	ウワジクL	ARM SHAFT (L)	
11-1	S08689001	1	テンピンクランククミ	NEEDLE BAR CRANK ASSY	
18-1	014760622	3	アナトメネジ5.95	SET SCREW, SOCKET SM5.95	
31	S08715016	1	ミシンハリUYX128GAS	NEEDLE, UYX128GAS (#16)	
35-1	S08716301	1	ハリイタササエイタ	SUPPORTER PLATE, NEEDLE PLATE	
37-1	062680812	1	ナベコ437-40X8	SCREW, PAN SM4.37-40X8	
53-1	S08756001	1	ハリウケB	NEEDLE GUARD REAR	
			<012-T>	<012-T>	
8-1	S08687001	1	ウワジクL	ARM SHAFT (L)	
11-1	S08689001	1	テンピンクランククミ	NEEDLE BAR CRANK ASSY	
18-1	014760622	3	アナトメネジ5.95	SET SCREW, SOCKET SM5.95	
31	S08715016	2	ミシンハリUYX128GAS	NEEDLE, UYX128GAS (#16)	
35-1	S08716301	1	ハリイタササエイタ	SUPPORTER PLATE, NEEDLE PLATE	
37-1	062680812	1	ナベコ437-40X8	SCREW, PAN SM4.37-40X8	
53-2	S40967001	1	ウシロハリウケT	REAR NEEDLE GUARD (T)	
			<012-5>	<012-5>	
8-1	S08687001	1	ウワジクL	ARM SHAFT (L)	
11-1	S08689001	1	テンピンクランククミ	NEEDLE BAR CRANK ASSY	
18-1	014760622	3	アナトメネジ5.95	SET SCREW, SOCKET SM5.95	
31	S08715016	2	ミシンハリUYX128GAS	NEEDLE, UYX128GAS (#16)	
35-1	S08716301	1	ハリイタササエイタ	SUPPORTER PLATE, NEEDLE PLATE	
37-1	062680812	1	ナベコ437-40X8	SCREW, PAN SM4.37-40X8	
53-3	S40985101	1	ウシロハリウケH	REAR NEEDLE GUARD (H)	
55	S40965001	1	マエハリウケドダイ	FRONT NEEDLE GUARD MOUNTING BASE	
56	062671012	2	ナベコ357-40X10	SCREW, PAN SM3.57-40X10	
57	014680422	1	アナトメネジ4.37クボミ	SET SCREW, SOCKET (CP) SM4.37	
58	S40966001	1	マエハリウケホルダー	FRONT NEEDLE GUARD HOLDER	
59	014680422	1	アナトメネジ4.37クボミ	SET SCREW, SOCKET (CP) SM4.37	
60-3	S40986101	1	マエハリウケH	FRONT NEEDLE GUARD (H)	
			<013-□>	<013-□>	
8-1	S08687001	1	ウワジクL	ARM SHAFT (L)	
11-2	S12725101	1	ハリボウ克蘭ククミ	NEEDLE BAR CRANK ASSY	
18-2	152718001	3	アナトメネジ5.95	SET SCREW, SOCKET M5.95	
26	081046870	2	OリングS46	O RING, S46	
31	S08715021	2	ミシンハリUYX128GAS	NEEDLE, UYX128GAS	
35-3	S44882001	1	ハリイタササエイタ	SUPPORTER PLATE, NEEDLE PLATE	
37-1	062680812	1	ナベコ437-40X8	SCREW, PAN SM4.37-40X8	
53-3	S40985101	1	ウシロハリウケH	REAR NEEDLE GUARD (H)	
55	S40965001	1	マエハリウケドダイ	FRONT NEEDLE GUARD MOUNTING BASE	
56	062671012	2	ナベコ357-40X10	SCREW, PAN SM3.57-40X10	
57	014680422	1	アナトメネジ4.37クボミ	SET SCREW, SOCKET (CP) SM4.37	
58	S40966001	1	マエハリウケホルダー	FRONT NEEDLE GUARD HOLDER	
59	014680422	1	アナトメネジ4.37クボミ	SET SCREW, SOCKET (CP) SM4.37	
60-3	S40986101	1	マエハリウケH	FRONT NEEDLE GUARD (H)	
			<014-□>	<014-□>	
8-1	S08687001	1	ウワジクL	ARM SHAFT (L)	
11-2	S12725101	1	ハリボウ克蘭ククミ	NEEDLE BAR CRANK ASSY	
18-2	152718001	3	アナトメネジ5.95	SET SCREW, SOCKET M5.95	
26	081046870	2	OリングS46	O RING, S46	
31	S08715022	2	ミシンハリUYX128GAS	NEEDLE, UYX128GAS	
35-3	S44882001	1	ハリイタササエイタ	SUPPORTER PLATE, NEEDLE PLATE	
37-1	062680812	1	ナベコ437-40X8	SCREW, PAN SM4.37-40X8	
53-3	S40985101	1	ウシロハリウケH	REAR NEEDLE GUARD (H)	
55	S40965001	1	マエハリウケドダイ	FRONT NEEDLE GUARD MOUNTING BASE	
56	062671012	2	ナベコ357-40X10	SCREW, PAN SM3.57-40X10	
57	014680422	1	アナトメネジ4.37クボミ	SET SCREW, SOCKET (CP) SM4.37	
58	S40966001	1	マエハリウケホルダー	FRONT NEEDLE GUARD HOLDER	
59	014680422	1	アナトメネジ4.37クボミ	SET SCREW, SOCKET (CP) SM4.37	
60-3	S40986101	1	マエハリウケH	FRONT NEEDLE GUARD (H)	



B. 上軸・針棒関係 / Upper shaft and needle bar mechanism / Obere Welle und Nadelstangenvorrichtung / Mécanisme de arbre supérieur et barra à aiguille / Mecanismo del eje superior y la barra de aguja

<012-0、0D2-0>

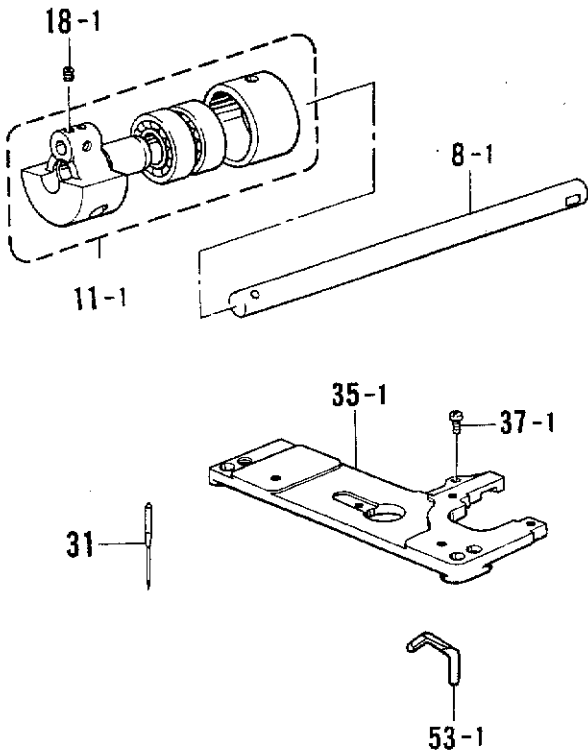

<012-T>

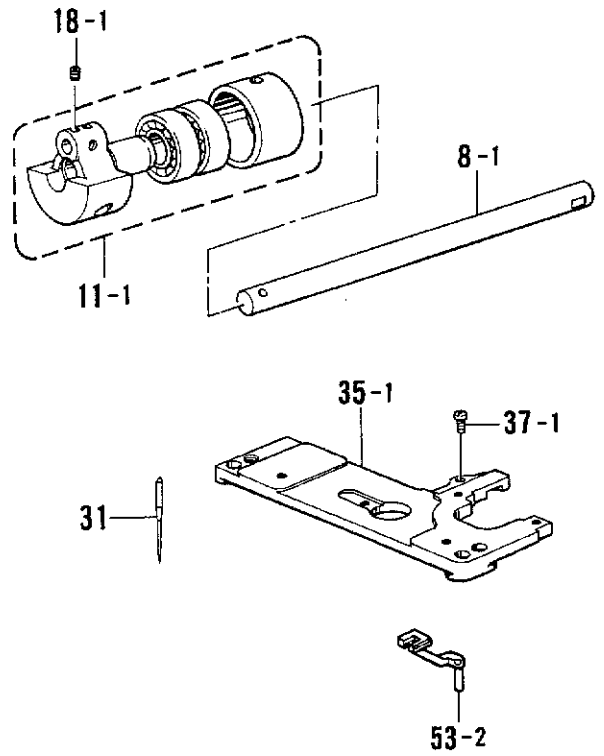

<012-5>

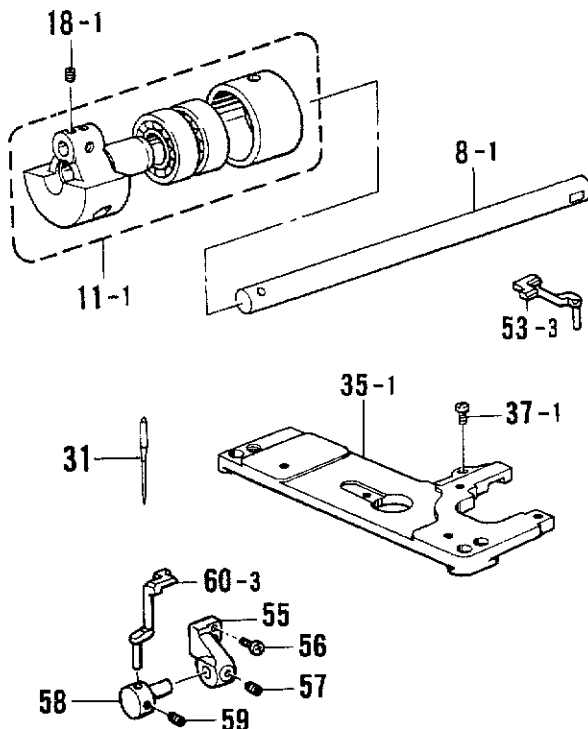

<013-□、014-□>

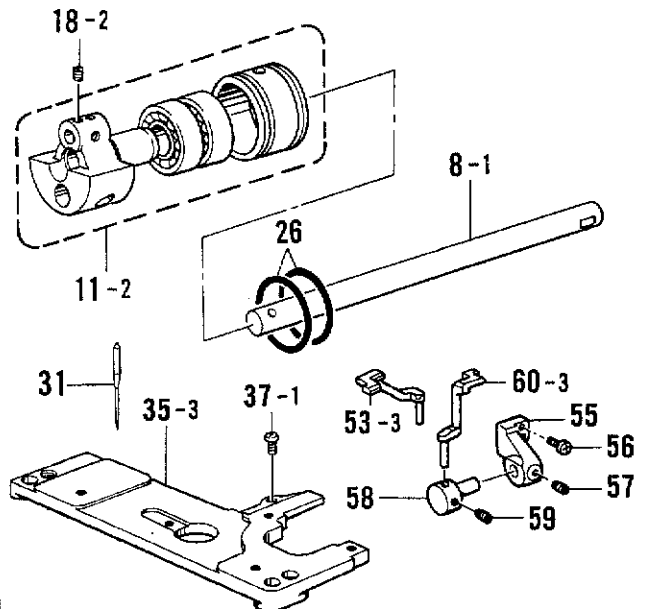

<□/RP1>

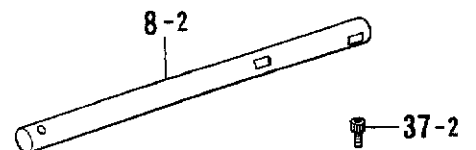

B. 上軸・針棒関係 / Upper shaft and needle bar mechanism / Obere Welle und Nadelstangenvorrichtung / Mécanisme de arbre supérieur et barra à aiguille / Mecanismo del eje superior y la barra de aguaja

REF.NO.	CODE	Q'TY	ヒンメイ	NAME OF PARTS	RM
			<013-□/RP1>	<013-□/RP1>	
8-2	S12724001	1	ウワジクL	UPPER SHAFT, L	
11-2	S12725101	1	ハリボウ克蘭ククミ	NEEDLE BAR CRANK ASSY	
18-2	152718001	3	アナトメネジ5.95	SET SCREW, SOCKET M5.95	
26	081046870	2	OリングS46	O RING, S46	
31	S08715021	2	ミシンハリUYX128GAS	NEEDLE, UYX128GAS	
35-3	S44882001	1	ハリイタササエイタ	SUPPORTER PLATE, NEEDLE PLATE	
37-2	018681022	1	アナボルト4.37X10	BOLT, SOCKET SM4.37X10	
53-3	S40985101	1	ウシロハリウケH	REAR NEEDLE GUARD (H)	
55	S40965001	1	マエハリウケドダイ	FRONT NEEDLE GUARD MOUNTING BASE	
56	062671012	2	ナベコ357-40X10	SCREW, PAN SM3.57-40X10	
57	014680422	1	アナトメネジ4.37クボミ	SET SCREW, SOCKET (CP) SM4.37	
58	S40966001	1	マエハリウケホルダー	FRONT NEEDLE GUARD HOLDER	
59	014680422	1	アナトメネジ4.37クボミ	SET SCREW, SOCKET (CP) SM4.37	
60-3	S40986101	1	マエハリウケH	FRONT NEEDLE GUARD (H)	
			<014-□/RP1>	<014-□/RP1>	
8-2	S12724001	1	ウワジクL	UPPER SHAFT, L	
11-2	S12725101	1	ハリボウ克蘭ククミ	NEEDLE BAR CRANK ASSY	
18-2	152718001	3	アナトメネジ5.95	SET SCREW, SOCKET M5.95	
26	081046870	2	OリングS46	O RING, S46	
31	S08715022	2	ミシンハリUYX128GAS	NEEDLE, UYX128GAS	
35-3	S44882001	1	ハリイタササエイタ	SUPPORTER PLATE, NEEDLE PLATE	
37-2	018681022	1	アナボルト4.37X10	BOLT, SOCKET SM4.37X10	
53-3	S40985101	1	ウシロハリウケH	REAR NEEDLE GUARD (H)	
55	S40965001	1	マエハリウケドダイ	FRONT NEEDLE GUARD MOUNTING BASE	
56	062671012	2	ナベコ357-40X10	SCREW, PAN SM3.57-40X10	
57	014680422	1	アナトメネジ4.37クボミ	SET SCREW, SOCKET (CP) SM4.37	
58	S40966001	1	マエハリウケホルダー	FRONT NEEDLE GUARD HOLDER	
59	014680422	1	アナトメネジ4.37クボミ	SET SCREW, SOCKET (CP) SM4.37	
60-3	S40986101	1	マエハリウケH	FRONT NEEDLE GUARD (H)	

C. 針冷却関係 / Needle cooler / Nadelkühlungsvorrichtung / Mécanisme du refroidisseur d'aiguille / Mecanismo del enfriador de aguja

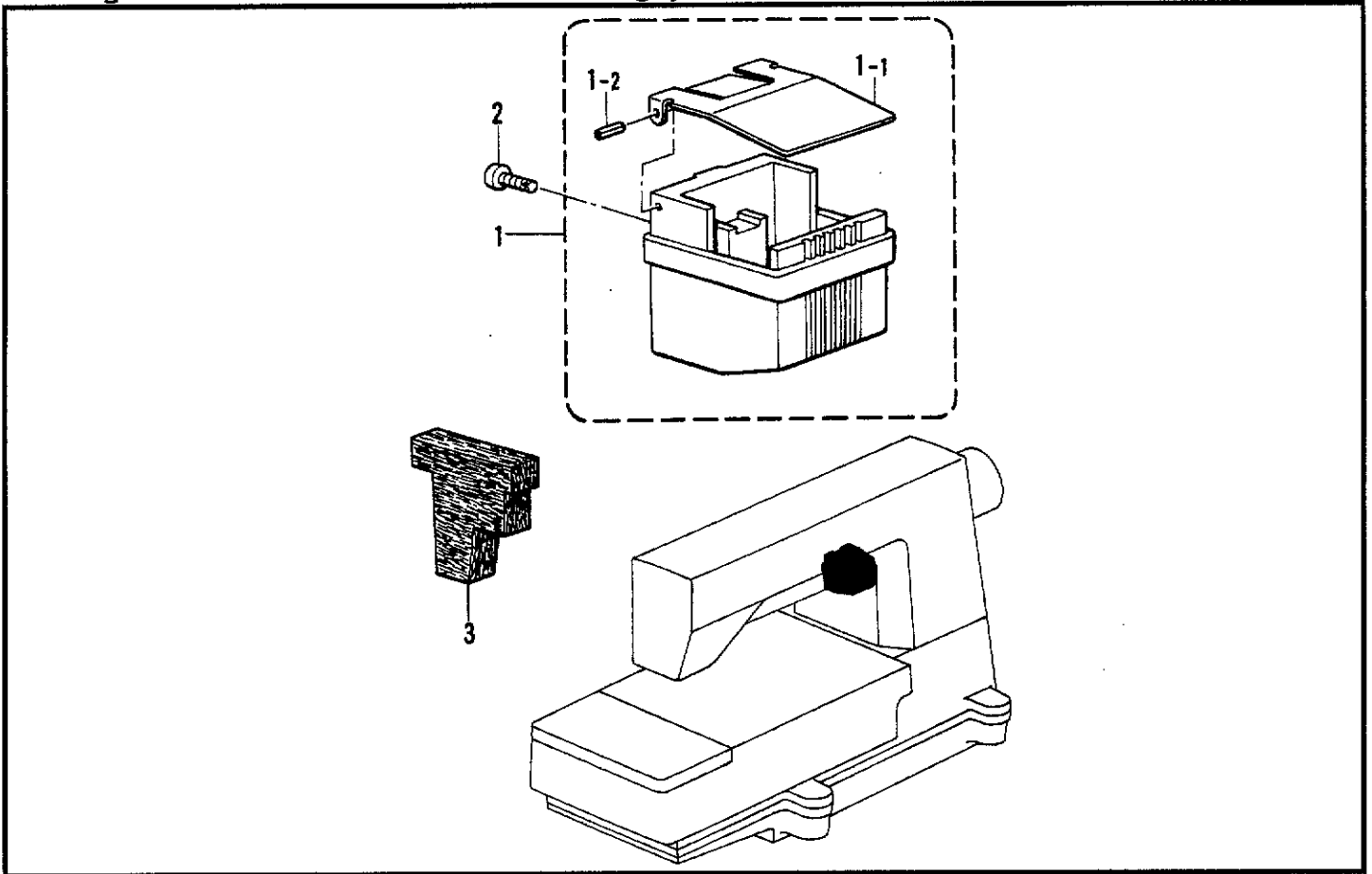

118-261-124

D. ラッパー関係 / Lapper mechanism / Falz-mechanismus / Mécanisme à rabat / Mecanismo de solapado

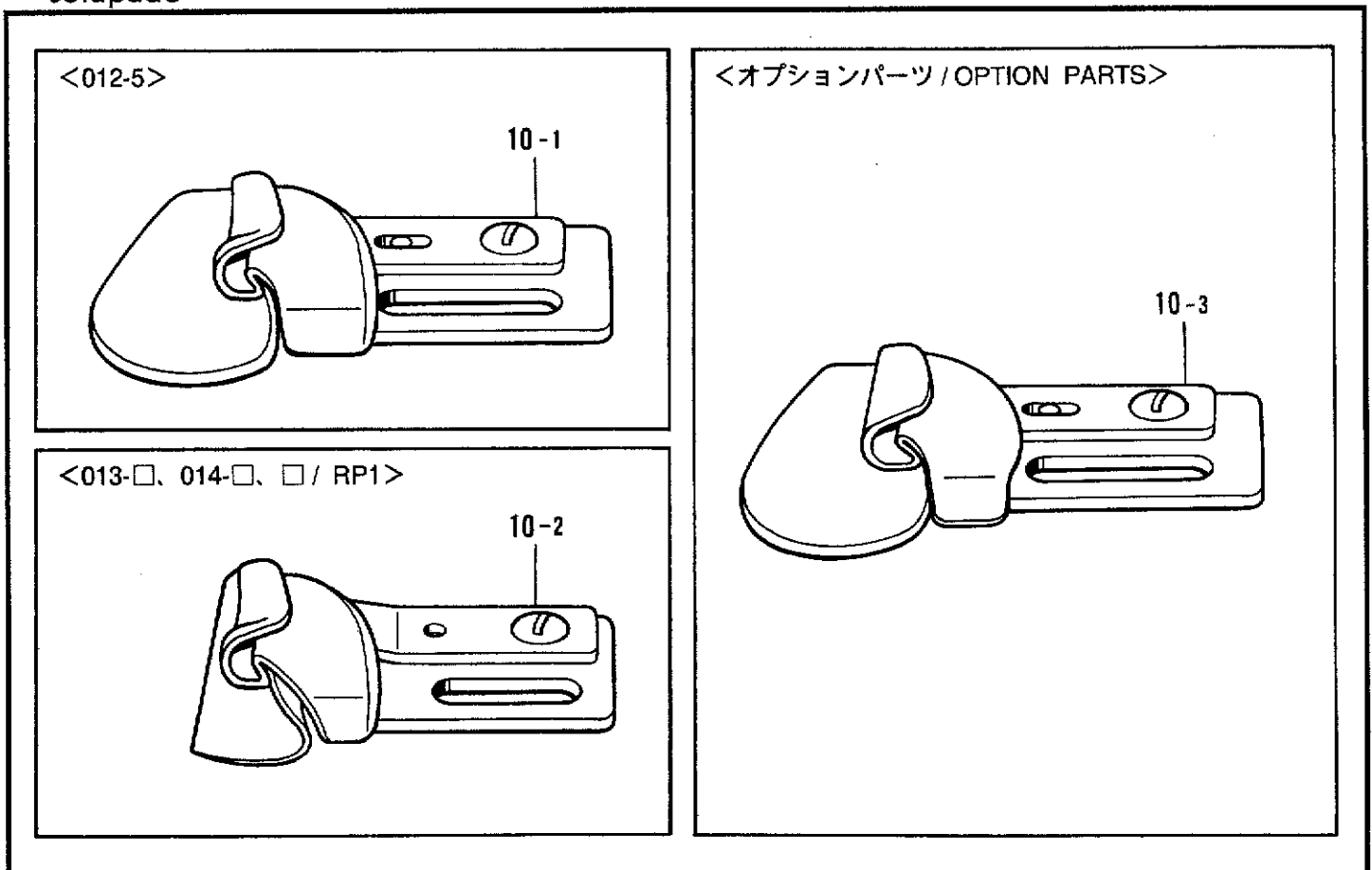

118-261-239

C. 針冷却関係 / Needle cooler / Nadelkühlungsvorrichtung / Mécanisme du refroidisseur d'aiguille / Mecanismo del enfriador de aguja

REF.NO.	CODE	Q'TY	ヒンメイ	NAME OF PARTS	RM
1	S08758109	1	ハライトレイキヤクタンククミ	NEEDLE THREAD COOLER TANK ASSY	
1-1	S08760009	1	ハライトレイキヤクタンクフタ	N/THREAD COOLER TANK COVER	
1-2	047200642	2	スプリングピンAW2	PIN, SPRING ROLL AW2	
2	087311215	2	カツプBタイト3X12	TAPTITE, CUP B M3X12	
3	S08761100	1	ハライトレイキヤクフェルト	FELT	

118-261-124

D. ラッパ関係 / Lapper mechanism / Falz-mechanismus / Mécanisme à rabat / Mecanismo de solapado

REF.NO.	CODE	Q'TY	ヒンメイ	NAME OF PARTS	RM
10-1	113880001	1	<012-5> ラツパークミ1/4	<012-5> LAPPER 1/4" ASSY	
10-2	S44912000	1	<013-□,014-□,□/RP1> ラツパー1/4XHクミ	<013-□,014-□,□/RP1> LAPPER 1/4XH ASSY	
10-3	151584001	1	<オプションパーツ> ラツパー1/4Mクミ	<OPTION PARTS> LAPPER ASSY 1/4"M ASSEMBLY	

118-261-239

E. 押工関係 / Presser foot mechanism / Stoffdrückerfuß / Mécanisme de pied presseur / Mecanismo de la prensa tela

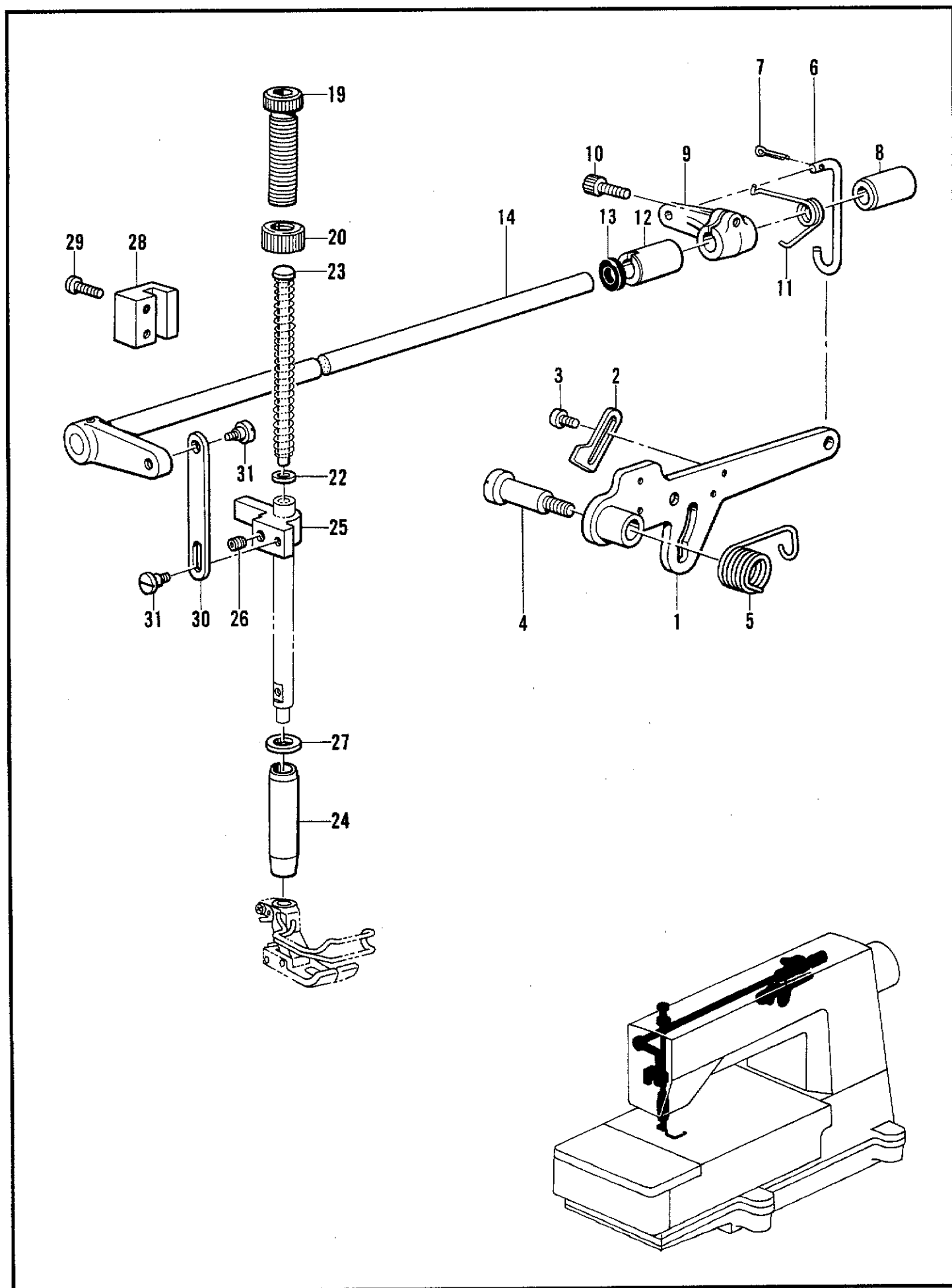

E. 押工関係 / Presser foot mechanism / Stoffdrückerfuß / Mécanisme de pied presseur / Mecanismo de la prensa tela

REF.NO.	CODE	Q'TY	ヒンメイ	NAME OF PARTS	RM
1	S08767001	1	オサエアゲレバーR	PRESSER BAR LIFTER LEVER (R)	
2	S08768001	1	オサエアゲストツバ	PRESSER BAR LIFTER LEVER STOPPER	
3	060680712	2	バインド437-40X7	SCREW, BIND SM4.37-40X7	
4	148372001	1	ダンネジ7.94	STUD SCREW, M7.94	
5	143325001	1	オサエアシアゲレバーバネ	SPRING	
6	S08769001	1	オサエアゲリンク	PRESSER BAR LIFTER LINK	
7	110793001	1	ワリピン	PIN, COTTER	
8	155220000	1	ホジヨアツメタルR	AUTO PRESSER ARM BUSH (R)	
9	154956001	1	オサエアシアゲMレバー	PRESSER FOOT LIFTER INSIDE LEVER	
10	018771432	1	アナボルト635-40X14	BOLT, SOCKET SM6.35-40X14	
11	154957001	1	オサエアゲMレバーバネ	SPRING	
12	S08770000	1	ジクメタル	SHAFT BUSH	
13	155539000	1	ダストシール	DUST SEAL	
14	S08771001	1	オサエアゲレバーLクミ	PRESSER BAR LIFTER LEVER (L) ASSY	
19	S31012001	1	オサエチヨウセツネジ	PRESSER ADJUSTING SCREW	
20	S31013001	1	チヨウセツネジツマミナツト	PRESSER ADJUSTING NUT	
22	140407001	1	ザガネ	WASHER	
23	141208001	1	オサエバネアンナイ	SPRING GUIDE	
24	145472001	1	オサエボウメタル	PRESSER BAR BUSH	
25	S00879001	1	オサエボウダキ	PRESSER BAR CLAMP	
26	014760622	1	アナトメネジ5.95	SET SCREW, SOCKET SM5.95	
27	154596000	1	イトキリカムレバークツシヨン	CUSHION	
28	S08775000	1	オサエボウアンナイ	PRESSER BAR GUIDE	
29	062681412	2	ナベコ437-40X14	SCREW, PAN SM4.37-40X14	
30	S08776001	1	オサエアゲイタ	PRESSER BAR LIFTER PLATE	
31	S08777001	2	ダンネジ4.37	SHOULDER SCREW, M4.37	

E. 押工関係 / Presser foot mechanism / Stoffdrückerfuß / Mécanisme de pied presseur / Mecanismo de la prensa tela

<012-0、0D2-0、012-T>

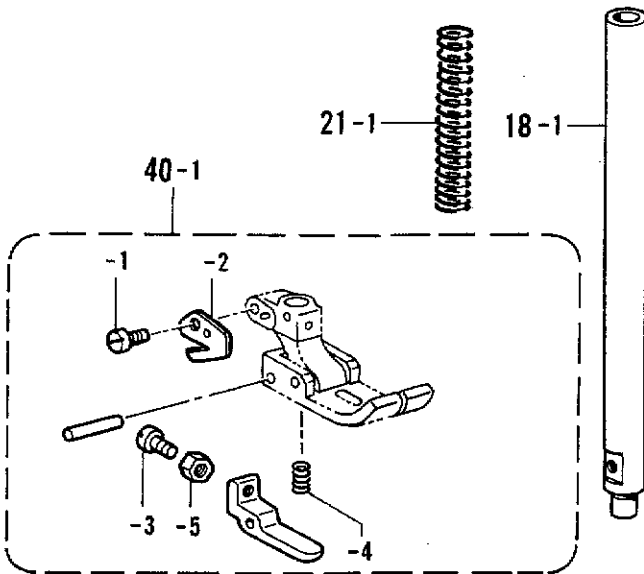

<012-5>

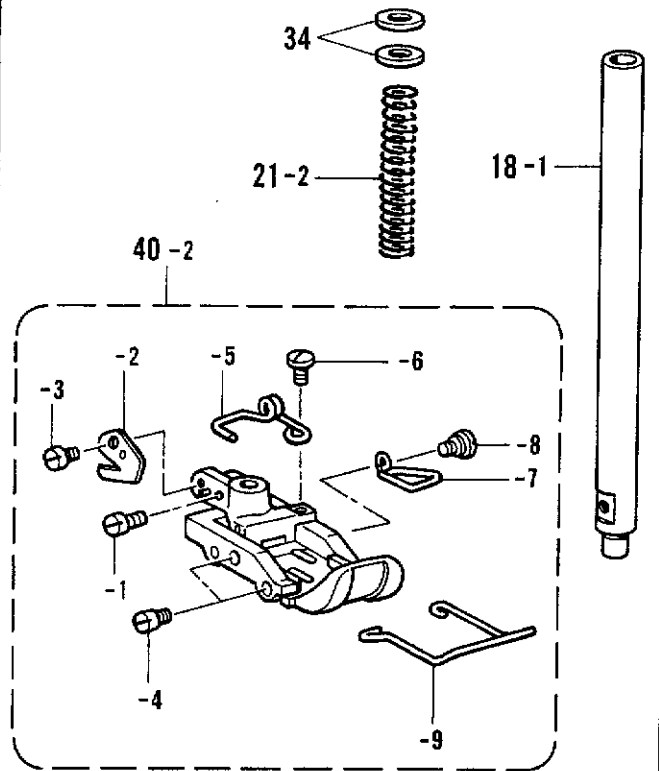

<012-0>

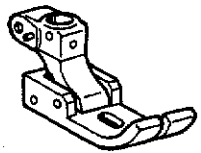

<0D2-0>

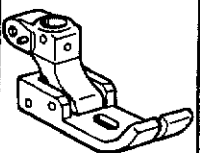

<012-T>

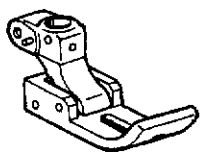

<オプションパーツ / OPTION PARTS>

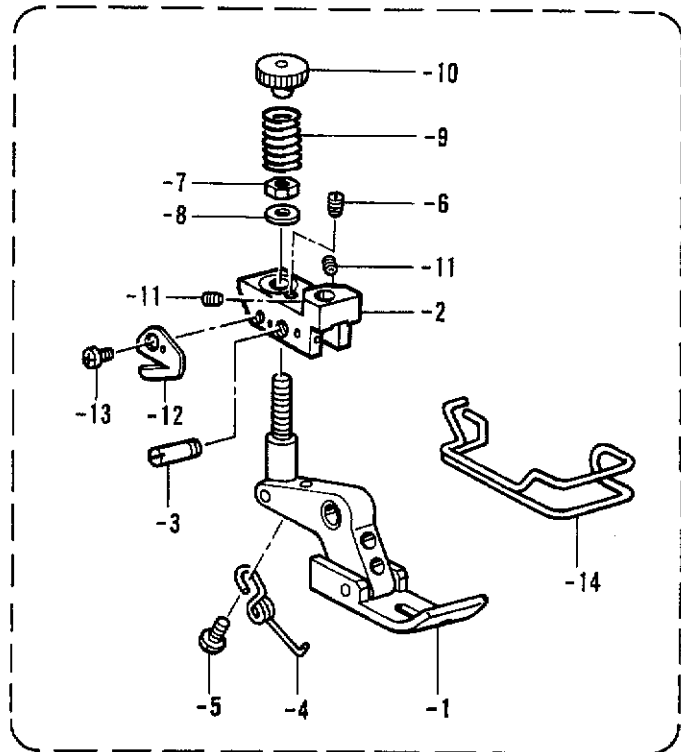
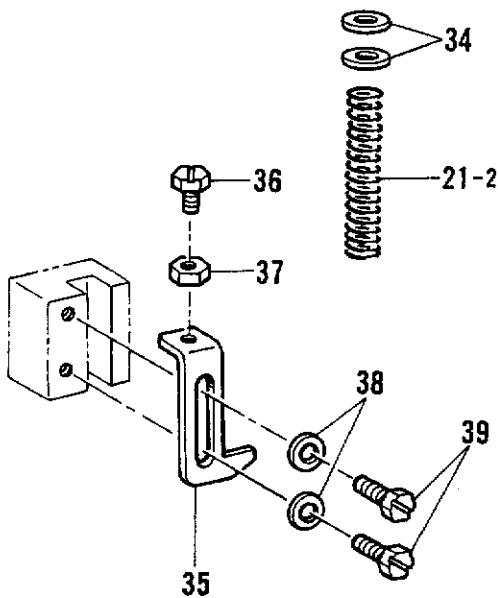

40-3

E. 押工関係 / Presser foot mechanism / Stoffdrückerfuß / Mécanisme de pied presseur / Mecanismo de la prensa tela

REF.NO.	CODE	Q'TY	ヒンメイ	NAME OF PARTS	RM
			<012-0,012-T,0D2-0>	<012-0,012-T,0D2-0>	
18-1	S08774001	1	オサエボウ	PRESSER BAR	
21-1	141728001	1	オサエバネ	PRESSER SPRING	
40-1	※	1	オサエクミ	PRESSER FOOT ASSY	
40-1-1	062671212	1	ナベコ357-40X12	SCREW, PAN SM3.57-40X12	
40-1-2	S20118151	1	カラヌイメス	TRIMMING KNIFE	
40-1-3	062630612	1	ナベコ238-56X6	SCREW, PAN SM2.38-56X6	
40-1-4	S40546001	1	カラカンオサエバネ	SPRING	
40-1-5	021630102	1	ナツト1シユ2.	NUT, 1 M2	
			<012-5>	<012-5>	
18-1	S08774001	1	オサエボウ	PRESSER BAR	
21-2	S18947001	1	オサエバネ	PRESSER SPRING, -3	
34	140407001	2	ザガネ	WASHER	
40-2	※	1	オサエ1/4クミ	PRESSER FOOT ASSY	
40-2-1	100064005	1	シメネジ3.57	SCREW, SM3.57	
40-2-2	S20118151	1	カラヌイメス	TRIMMING KNIFE	
40-2-3	062670412	1	ナベコ357-40X4	SCREW, PAN SM3.57-40X4	
40-2-4	147871001	4	オサエピン	PIN	
40-2-5	S40358101	1	オサエMバネ	SPRING, M	
40-2-6	111105002	1	シメネジ2.38	SCREW, SM2.38	
40-2-7	S40360001	1	オサエFバネ	SPRING	
40-2-8	147932001	1	ダンネジ2.38	SHOULDER SCREW, SM2.38	
40-2-9	S40374001	1	フィンガーガード	FINGER GUARD	
			<オプションパーツ>	<OPTION PARTS>	
21-2	S18947001	1	オサエバネ	PRESSER SPRING, -3	
34	140407001	2	ザガネ	WASHER	
35	S40539001	1	オサエボウストツバ	PRESSER BAR STOPPER	
36	154574001	1	ボルト4.37	BOLT, SM4.37	
37	102571003	1	ナツト4.37	NUT, SM4.37	
38	100645003	2	ザガネ	WASHER	
39	117516001	2	ボルト4.37	BOLT, M4.37	
40-3	※	1	Fオサエクミ	F. PRESSER FOOT ASSY	
40-3-1	S40549101	1	Fオサエコグミ	F. PRESSER FOOT BOTTOM ASSY	
40-3-2	S40544101	1	Fオサエシジタイクミ	PRESSER FOOT BASE	
40-3-3	S40555001	1	オサエシジピン	PRESSER FOOT PIN	
40-3-4	S40556001	1	オサエホジバネ	SPRING	
40-3-5	111105002	1	シメネジ2.38	SCREW, SM2.38	
40-3-6	S13085001	1	トメネジ3.18	SET SCREW, SM3.18	
40-3-7	021670202	1	ナツト2シユ3.57	NUT, 2 SM3.57	
40-3-8	105161004	1	ザガネ	WASHER	
40-3-9	S40558001	1	オサエバネ	PRESSER SPRING	
40-3-10	S40557001	1	オサエバネナツト	PRESSER SPRING NUT	
40-3-11	014680422	2	アナトメネジ4.37クボミ	SET SCREW, SOCKET (CP) SM4.37	
40-3-12	S20118151	1	カラヌイメス	TRIMMING KNIFE	
40-3-13	062670412	1	ナベコ357-40X4	SCREW, PAN SM3.57-40X4	
40-3-14	S36894000	1	フィンガーガード	FINGER GUARD	



E. 押工関係 / Presser foot mechanism / Stoffdrückerfuß / Mécanisme de pied presseur / Mecanismo de la prensa tela

<013-□, 014-□, □ / RP1>

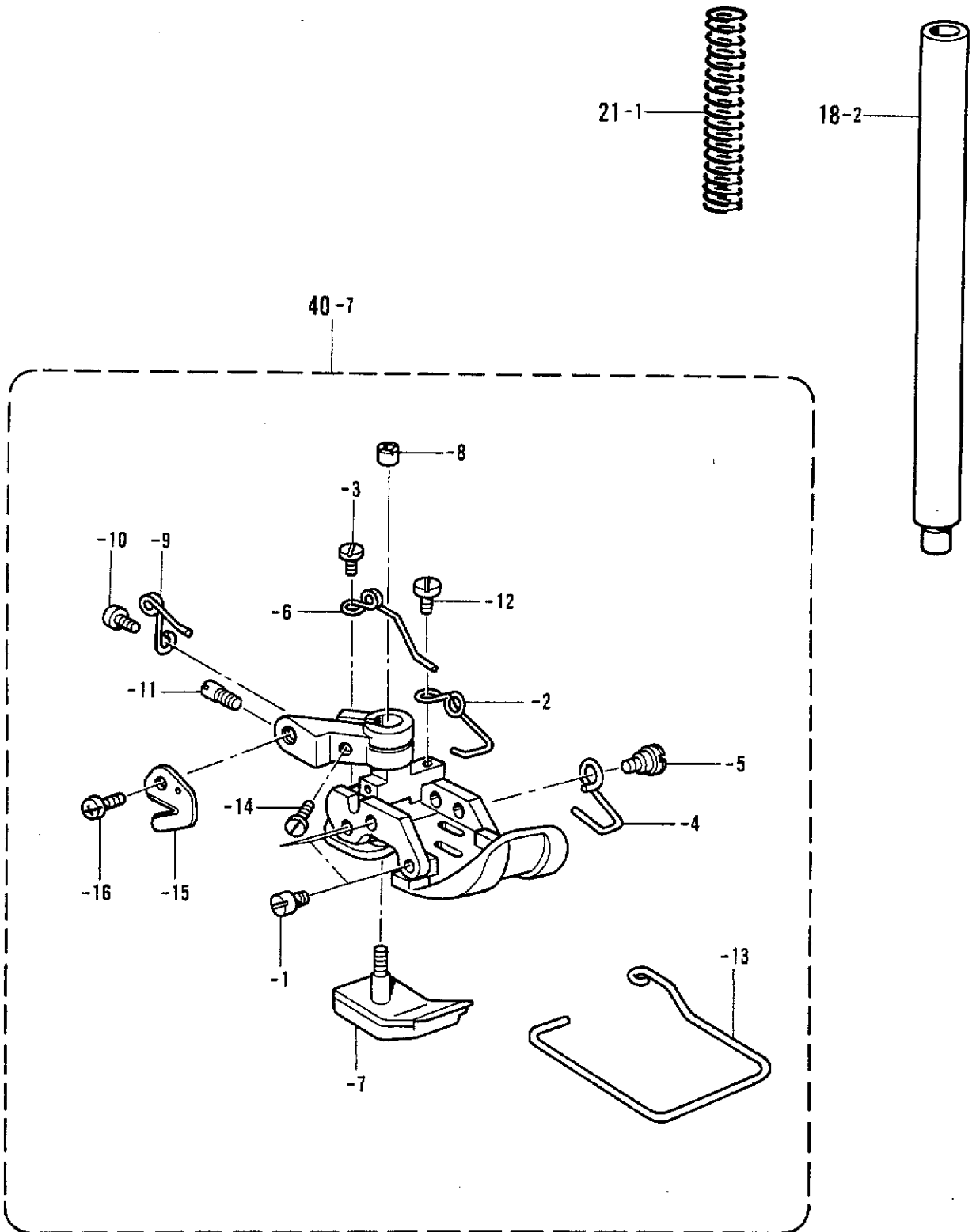

E. 押工関係 / Presser foot mechanism / Stoffdrückerfuß / Mécanisme de pied presseur / Mecanismo de la prensa tela

REF.NO.	CODE	Q'TY	品名	NAME OF PARTS	RM
			<013-□,014-□>	<013-□,014-□>	
18-2	S44887001	1	オサエボウ	PRESSER BAR	
21-1	141728001	1	オサエバネ	PRESSER SPRING	
40-7	※	1	オサエ1/4クミ	PRESSER FOOT ASSY	
40-7-1	147871001	6	オサエピン	PIN	
40-7-2	147872001	1	オサエMバネ	SPRING	
40-7-3	S01295001	1	シメネジ2.38X3.5	SCREW, SM2.38X3.5	
40-7-4	147890001	1	オサエFバネ	SPRING	
40-7-5	147932001	1	ダンネジ2.38	SHOULDER SCREW, SM2.38	
40-7-6	147875001	1	オサエBLバネ	SPRING	
40-7-7	147876001	1	オサエBS	PRESSER FOOT, BS	
40-7-8	147877001	1	ツマミナット3.18	NUT, SM3.18	
40-7-9	147878001	1	オサエBSバネ	SPRING	
40-7-10	062660512	1	ナベコネジ318-40X5	SCREW, PAN SM3.18-40X5	
40-7-11	147879001	1	トメネジ3.18	SET SCREW, SM3.18	
40-7-12	111105002	1	シメネジ2.38	SCREW, SM2.38	
40-7-13	151572101	1	フィンガーガード	FINGER GUARD	
40-7-14	100064005	1	シメネジ3.57	SCREW, SM3.57	
40-7-15	S20118151	1	カラヌイメス	TRIMMING KNIFE	
40-7-16	062670412	1	ナベコ357-40X4	SCREW, PAN SM3.57-40X4	

F. 送り関係 / Feed mechanism / Transportvorrichtung / Mécanisme de l'entraînement / Mecanismo de la alimentación

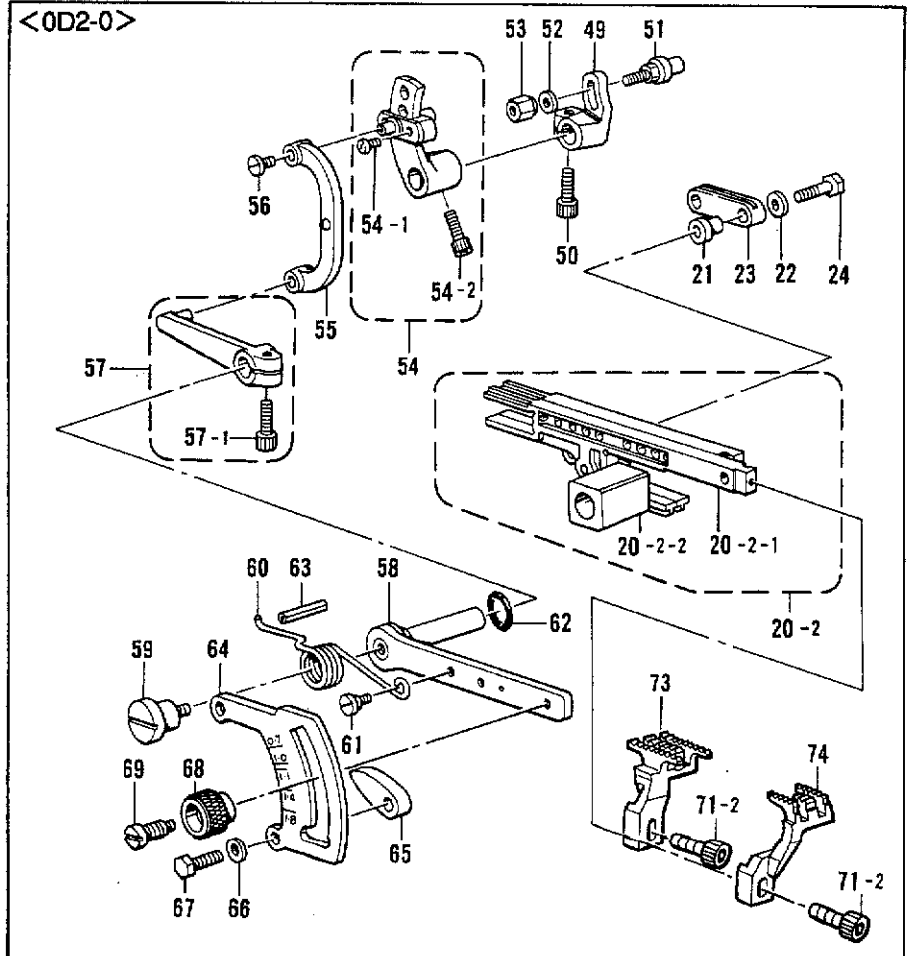
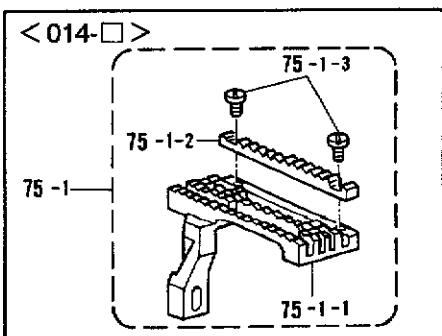
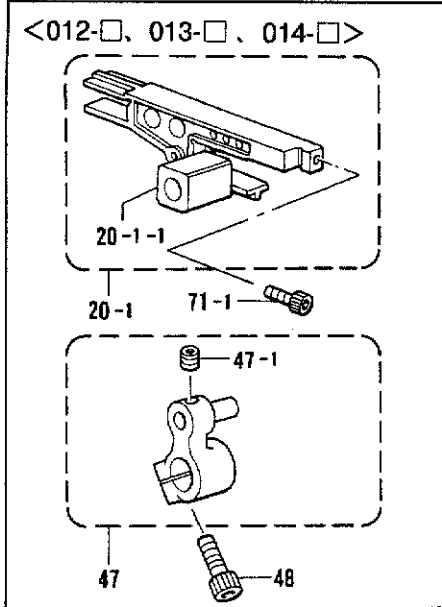
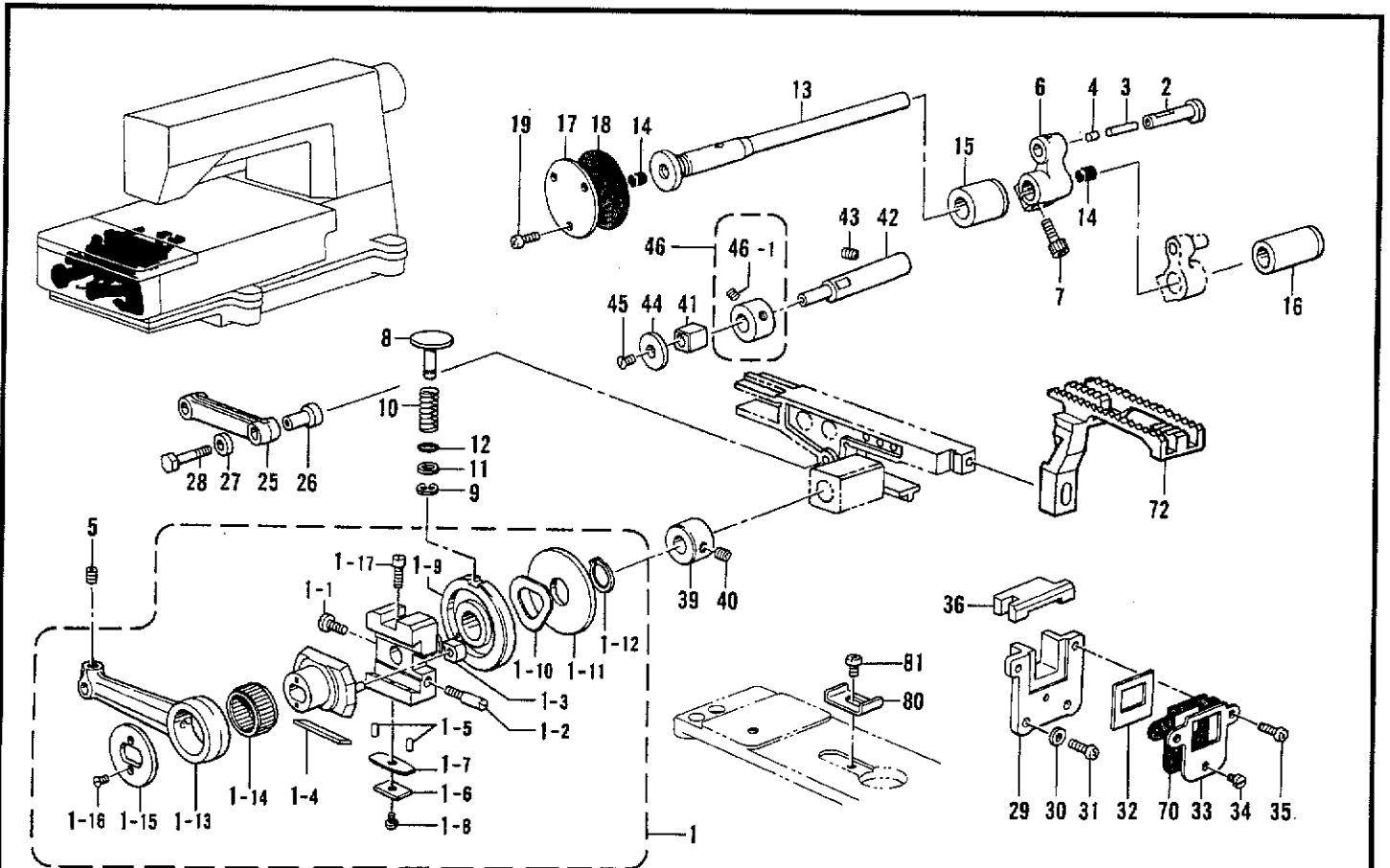

F. 送り関係 / Feed mechanism / Transportvorrichtung / Mécanisme de l'entraînement / Mecanismo de la alimentación

REF.NO.	CODE	Q'TY	ヒンメイ	NAME OF PARTS	RM
1	146528102	1	ヘンシンリンクミ	ECCENTRIC WHEEL ASSY	
1-1	S16498001	1	シメネジ4.37	SCREW, SM4.37	
1-2	145663001	1	トメネジ4.37	SET SCREW, SM4.37	
1-3	140165001	1	チヨウセツピンカワコマ	SLIDE BLOCK	
1-4	146401001	1	ジブ	GIB	
1-5	146402001	2	ジブオサエピン	PIN	
1-6	146403001	1	ジブオサエイタバネS	PLATE SPRING, S	
1-7	146404001	1	ジブオサエイタバネL	PLATE SPRING, L	
1-8	062660512	1	ナベコネジ318-40X5	SCREW, PAN SM3.18-40X5	
1-9	144053001	1	ヘンシンチヨウセツカムクミ	ECCENTRIC WHEEL ADJ. CAM ASSY	
1-10	144055001	1	ナミバネ	SPRING, WAVE	
1-11	146529001	1	ザガネ	WASHER	
1-12	048150143	1	トメワジクヨウC15	RETAINING RING, C15	
1-13	146530001	1	オクリロッド	FEED ROD	
1-14	146531001	1	ニードルジクウケ20	NEEDLE ROLLER BEARING 20	
1-15	140176001	1	オクリロッドオサエイタ	FEED ROD PRESSER PLATE	
1-16	117517003	2	サラネジ2.38	SCREW, FLAT SM2.38	
1-17	100025002	2	シメネジ4.76	SCREW, SM4.76	
2	146532001	1	オクリロッドピン	PIN	
3	147318000	1	ピン	PIN	
4	140326009	1	ゴムセン3.3	RUBBER CAP, 3.3	
5	100251001	1	トメネジ6.35	SET SCREW, SM6.35	
6	146533001	1	オクリウデ	FEED ARM	
7	018771432	1	アナボルト635-40X14	BOLT, SOCKET SM6.35-40X14	
8	S08870001	1	プツシユボタン	PUSH BUTTON	
9	048040342	1	トメワE4	RETAINING RING, E4	
10	S08871001	1	ボタンジクバネ	SPRING	
11	153484001	1	ザガネ4.76	WASHER, PLAIN 4.76	
12	081003670	1	OリングPW3	O RING, PW3	
13	146538101	1	オクリジク	FEED SHAFT	
14	140327001	2	ゴムセン6.3	RUBBER CAP, 6.3	
15	146539000	1	オクリジクメタルL	FEED SHAFT BUSH (L)	
16	146540000	1	オクリジクメタルR	FEED SHAFT BUSH (R)	
17	155144001	1	オクリジクメタルLフタ	FEED SHAFT BUSH (L) CAP	
18	155145000	1	パツキン	PACKING	
19	062670812	3	ナベコ3.57-40X8	SCREW, PAN SM3.57-40X8	
25	146554001	1	サドウオクリリンク	DIFFERENTIAL FEED LINK	
26	146555001	1	サドウオクリリンクブシユ	DIFFERENTIAL FEED LINK BUSH	
27	S23359001	1	ザガネ	WASHER	
28	140217001	1	オクリリンクジクL	FEED LINK SHAFT (L)	
29	155151000	1	オクリダイアンナイ	FEED BAR GUIDE	
30	100645003	2	ザガネ	WASHER	
31	062681012	2	ナベコ437-40X10	SCREW, PAN SM4.37-40X10	
32	155177100	1	ボウジンイタ	FRAGMENT PROTECTOR PLATE	
33	155178001	1	ボウジンイタササエ	FRAGMENT PROTECTOR SUPPORT	
34	S39086001	1	ナベコ357-40X3.5	SCREW, PAN SM3.57-40X3.5	
35	062681012	2	ナベコ437-40X10	SCREW, PAN SM4.37-40X10	
36	S08876000	1	オクリダイボウジンタイ	FEED BAR FRAGMENT PROTECTOR BASE	
39	146741000	1	セットカラー	SET SCREW COLLAR	
40	101706001	1	トメネジ6.35	SET SCREW, SM6.35	
41	146547000	1	オクリダイカクゴマ	FEED BAR SLIDE BLOCK	
42	146548101	1	オクリダイカクゴマジク	FEED BAR SLIDE BLOCK SHAFT	
43	014780622	1	アナトメネジ6.35クボミ	SET SCREW, SOCKET (CP) SM6.35	
44	S08877001	1	オクリダイカクゴマアテイタ	SLIDE PLATE	
45	107272002	1	サラネジ4.37	SCREW, FLAT SM4.37	
46	S03704002	1	セットカラークミ	SET SCREW COLLAR ASSY	
46-1	014770622	2	アナトメネジ6.35クボミ	SET SCREW, SOCKET (CP) SM6.35	
70	S08467000	1	パツキン	PACKING	
72	※	1	オクリバ	FEED DOG	
80	S16249001	1	プツシユボタンストツバ	PUSH BUTTON STOPPER	
81	060680512	1	バインド437-40X5	SCREW, BIND SM4.37-40X5	

F. 送り関係 / Feed mechanism / Transportvorrichtung / Mécanisme de l'entraînement / Mecanismo de la alimentación

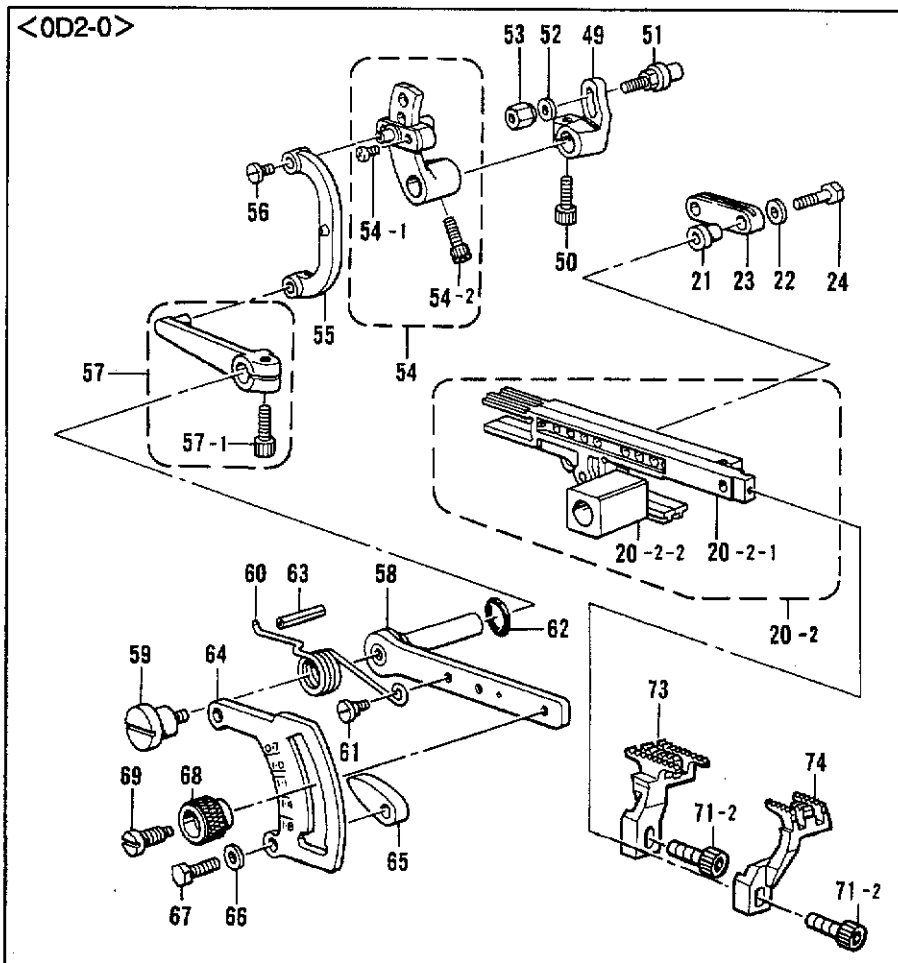
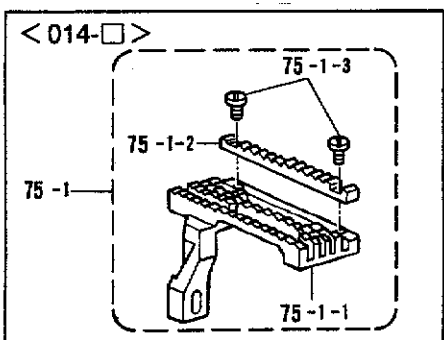
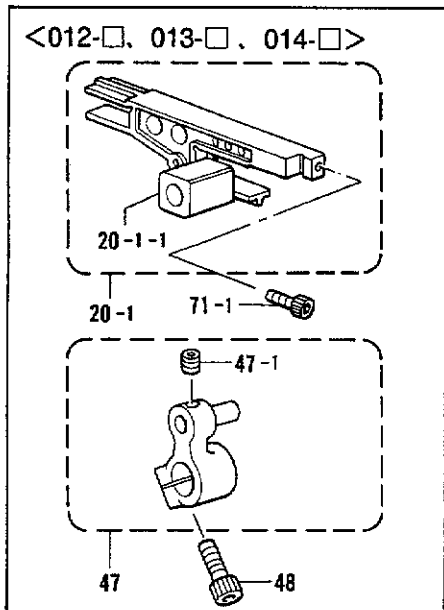
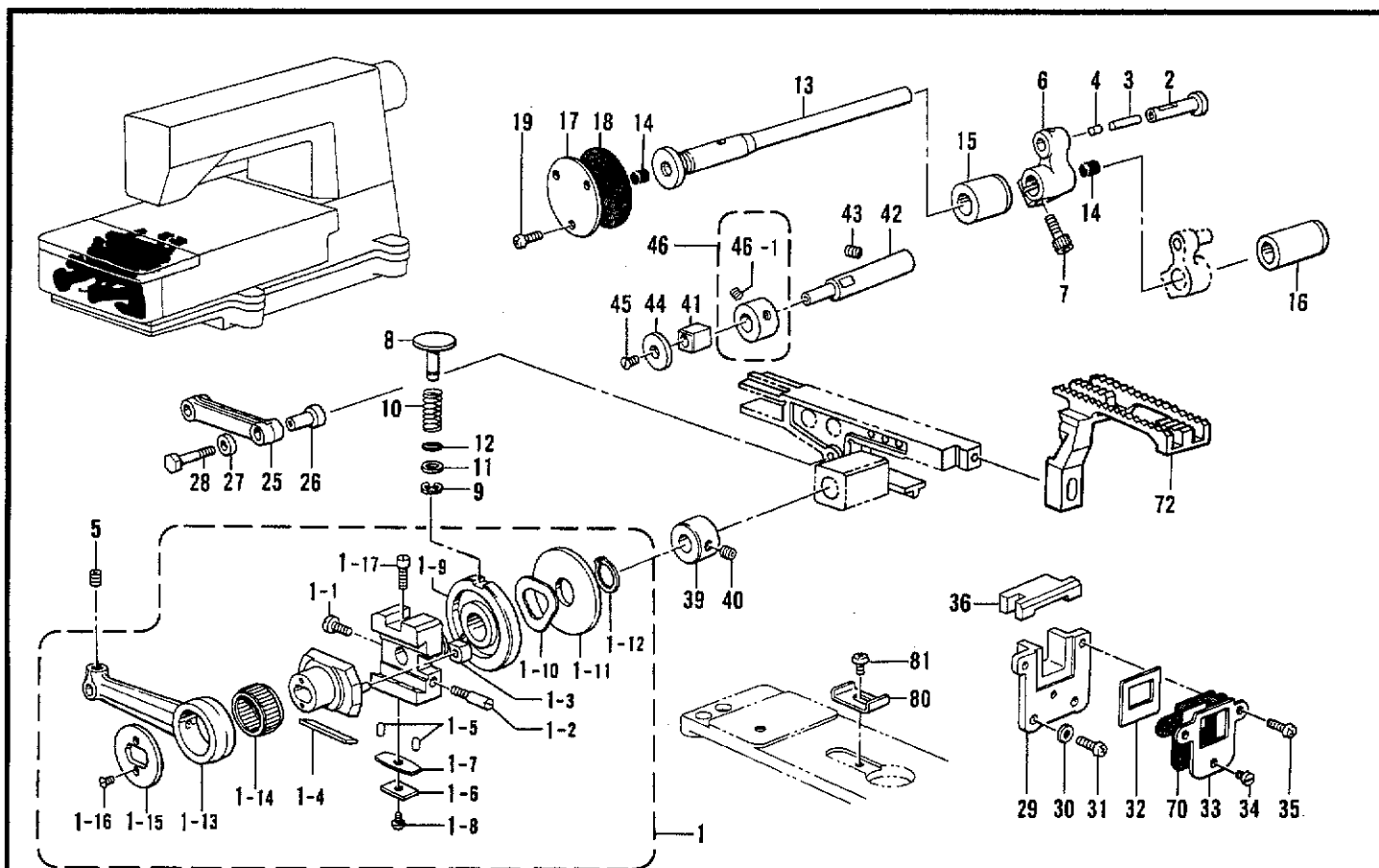

F. 送り関係 / Feed mechanism / Transportvorrichtung / Mécanisme de l'entraînement / Mecanismo de la alimentación

REF.NO.	CODE	Q'TY	ヒンメイ	NAME OF PARTS	RM
			<012-□,013-□,014-□>	<012-□,013-□,014-□>	
20-1	S40562001	1	オクリダイカクゴマクミ	FEED BAR SLIDE BLOCK ASSY	
20-1-1	146544000	1	ジヨウゲオクリカクゴマ	FEED LIFTING SLIDE BLOCK	
47	S40559001	1	オクリウデクミ	FEED ARM ASSY	
47-1	014770622	1	アナトメネジ6.35クボミ	SET SCREW, SOCKET (CP) SM6.35	
48	018771432	1	アナボルト635-40X14	BOLT, SOCKET SM6.35-40X14	
71-1	018501022	1	アナボルト5X10	BOLT, SOCKET M5X10	
			<014-□>	<014-□>	
75-1	※	1	オクリバクミ	FEED DOG ASSY	
75-1-1	S44902001	1	オクリバ	FEED DOG	
75-1-2	S44903001	1	トリツケバ	SUB FEED DOG	
75-1-3	147880001	2	シメネジ1.98	SCREW, M1.98	
			<0D2-0>	<0D2-0>	
20-2	S08872001	1	オクリダイカクゴマクミ	FEED BAR SLIDE BLOCK ASSY	
20-2-1	S08873001	1	オクリダイグミ	FEED BRACKET ASSY	
20-2-2	146544000	1	ジヨウゲオクリカクゴマ	FEED LIFTING SLIDE BLOCK	
21	140207001	1	シユオクリリンクブシユ	MAIN FEED LINK BUSH	
22	S23359001	1	ザガネ	WASHER	
23	140209001	1	シユオクリリンク	MAIN FEED LINK	
24	140210001	1	シユオクリリンクジクS	MAIN FEED LINK SHAFT (S)	
49	140205001	1	シユオクリウデ	MAIN FEED ARM	
50	018771432	1	アナボルト635-40X14	BOLT, SOCKET SM6.35-40X14	
51	143564001	1	シユオクリジク	MAIN FEED SHAFT	
52	113431002	1	ザガネ	WASHER	
53	143565001	1	ナツト4.76	NUT, SM4.76	
54	S08878001	1	サドウオクリウデクミ	DIFFERENTIAL FEED ARM ASSY	
54-1	062660712	2	ナベコ318-40X7	SCREW, PAN SM3.18-40X7	
54-2	018771432	1	アナボルト635-40X14	BOLT, SOCKET SM6.35-40X14	
55	146556001	1	サドウリンク	DIFFERENTIAL FEED ADJUST LINK	
56	148834001	1	シメネジ3.57	SCREW, M3.57	
57	S08879001	1	リンクレバーネジツキ	DIFFERENTIAL FEED LINK LEVER ASSY	
57-1	018771432	1	アナボルト635-40X14	BOLT, SOCKET SM6.35-40X14	
58	S08880001	1	サドウチヨウセツレバー	DIFFERENTIAL FEED ADJUST LEVER	
59	146559001	1	ダンネジ5.56	STUD SCREW, M5.56	
60	146560101	1	レバーバネ	LEVER SPRING	
61	100294002	1	ダンネジ4.76	SHOULDER SCREW, SM4.76	
62	109203001	1	Oリング	O RING	
63	047502242	1	スプリングピンAWS	PIN, SPRING ROLL AWS	
64	S08881101	1	サドウリヨウメモリイタ	DIFFERENTIAL STITCH CONTROL	
65	146563001	2	チヨウセツレバーストツバ	STOPPER FOR DIFFERENTIAL STITCH CONTROL	
66	025770232	2	ヒラザガネチユウ6.35	WASHER, PLAIN M 6.35	
67	017781412	2	ボルト6.35X14	BOLT, SM6.35X14	
68	155175051	1	セットネジツマミ	SET SCREW, KNOB	
69	155176001	1	セットネジ	SET SCREW	
71-2	154965001	2	アナボルト3.57X8	BOLT, SOCKET SM3.57X8	
73	※	1	シユオクリバ	MAIN FEED DOG	
74	※	1	サドウオクリバ	DIFFERENTIAL FEED DOG	

G. プーラ装置関係 / Puller device mechanism / Ziehvorrichtung / Mécanisme due puller / Mecanismo del dispositivo de arrastre

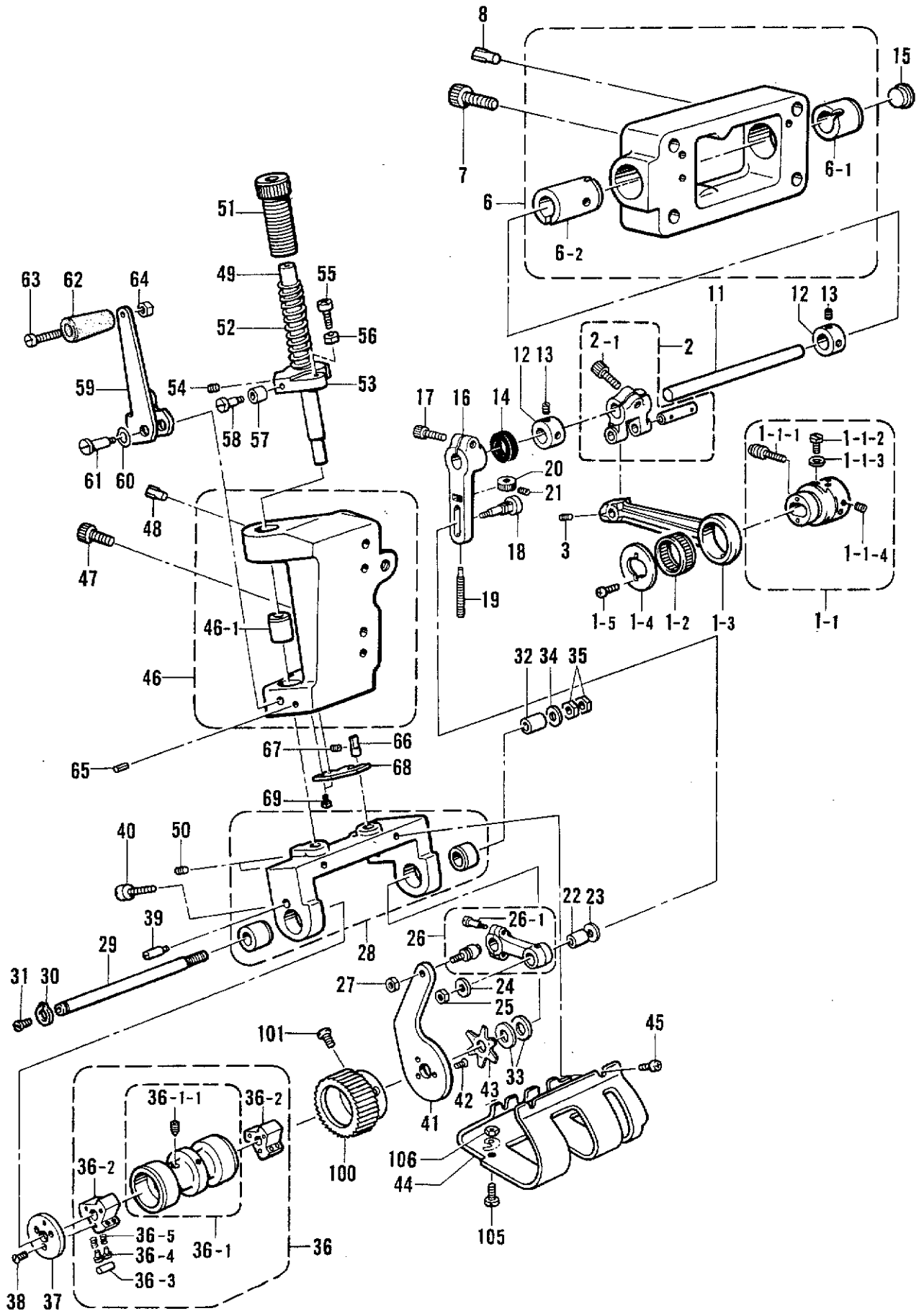

G. プーラ装置関係 / Puller device mechanism / Ziehvorrichtung / Mécanisme due puller / Mecanismo del dispositivo de arrastre

REF.NO.	CODE	Q'TY	ヒンメイ	NAME OF PARTS	RM
			<□/RP1>	<□/RP1>	
1	S13414201	1	プーラヘンシンリンロットクミ	PULLER ECCENTRIC WHEEL ROD ASSY	
1-1	S12913201	1	プーラヘンシンリンクミ	PULLER ECCENTRIC WHEEL ASSY	
1-1-1	113644001	1	ヘンシンリンチヨウセツネジ	ADJUST SCREW	
1-1-2	144075001	2	ボルト3.57	BOLT, SM3.57	
1-1-3	105161004	2	ザガネ	WASHER	
1-1-4	014760622	3	アナトメネジ5.95	SET SCREW, SOCKET SM5.95	
1-2	S12915001	1	ニードルジクウケ25	NEEDLE ROLLER BEARING 25	
1-3	S12916001	1	プーラロッド	PULLER ROD	
1-4	S12821001	1	レンカンオサエ	CONNECTING ROD PRESSER	
1-5	062630612	2	ナベコ238-56X6	SCREW, PAN SM2.38-56X6	
2	S17773001	1	クランクジクウデピンクミ	CRANK LEVER PIN ASSY	
2-1	018771432	1	アナボルト635-40X14	BOLT, SOCKET SM6.35-40X14	
3	014770622	1	アナトメネジ6.35クボミ	SET SCREW, SOCKET (CP) SM6.35	
6	S28250001	1	プーラブラケットRクミ	PULLER BRACKET (R) ASSY	
6-1	148120000	1	クランクジクメタルR	CRANK SHAFT BUSH (R)	
6-2	S28252000	1	プーラドウジクメタルL	PULLER DRIVING SHAFT BUSH (L)	
7	018063022	4	アナボルト6X30	BOLT, SOCKET M6X30	
8	117608001	2	ミゾツキピン	DOWEL PIN	
11	S28253001	1	プーラドウジク	PULLER DRIVING SHAFT	
12	140092001	2	セツトカラー	SET SCREW COLLAR	
13	014680422	4	アナトメネジ4.37クボミ	SET SCREW, SOCKET (CP) SM4.37	
14	S12918000	1	ダストシール	DUST SEAL	
15	159150009	1	ゴムセン20.5	RUBBER CAP, 20.5	
16	S12919001	1	プーラドウレバー	PULLER DRIVING LEVER	
17	018061622	1	アナボルト6X16	BOLT, SOCKET M6X16	
18	S12920001	1	プーラレンカンジク	PULLER CONNECTING SHAFT	
19	S12921001	1	チヨウセツネジ	ADJUST SCREW	
20	S12922001	1	ツマミ	KNOB	
21	148294001	1	アナトメネジ3.57クボミ	SET SCREW, SOCKET (CP) SM3.57	
22	S12923001	1	レンカンスリーブ	CONNECTING ROD SLEEVE	
23	156265001	1	ザガネ	WASHER, PLAIN 6	
24	107453001	1	ザガネ	WASHER	
25	110140001	1	ナット5.56	NUT, M5.56	
26	S12924001	1	プーラレンカンクミ	PULLER CONNECTING ROD ASSY	
26-1	100526003	2	ダンネジ3.57	SHOULDER SCREW, SM3.57	
27	110140001	1	ナット5.56	NUT, M5.56	
28	S28254001	1	プーラフレームクミ	PULLER FRAME ASSY	
29	S28256001	1	プーラジク	PULLER SHAFT	
30	048090142	1	トメワジクヨウC9	RETAINING RING, C9	
31	107272002	1	サラネジ4.37	SCREW, FLAT SM4.37	
32	S12933001	1	プーラブツシュ	PULLER BUSH	
33	S02556001	2	ザガネ	WASHER	
34	107153001	1	ザガネ	WASHER	
35	105812003	2	ナット7.94	NUT, SM7.94	
36	S12934101	1	プーラクラツチクミ	PULLER CLUTCH ASSY	
36-1	S13415101	1	プーラクラツチシユウクミ	PULLER CLUTCH SHOE ASSY	
36-1-1	118853001	1	アナトメネジ5.95	SET SCREW, SOCKET SM5.95	
36-2	S09039001	2	クラツチツメ	CLUTCH CLAW	
36-3	150604101	6	コロ	ROLLER	
36-4	150605001	12	クラツチピン	CLUTCH PIN	
36-5	S12900001	12	クラツチバネ	SPRING	
37	S12936001	1	クラツチイタ	CLUTCH PLATE	
38	106128004	3	サラネジ3.57	SCREW, FLAT SM3.57	
39	S12937101	1	スタッド	STUD	
40	121007001	1	アタマツキトメネジ4.37	SET SCREW, SM4.37	
41	S28334001	1	クラツチレバー	CLUTCH LEVER	
42	106128004	3	サラネジ3.57	SCREW, FLAT SM3.57	
43	S12939001	1	ホシガタバネ	SPRING	



G. プーラ装置関係 / Puller device mechanism / Ziehvorrichtung / Mécanisme due puller / Mecanismo del dispositivo de arrastre

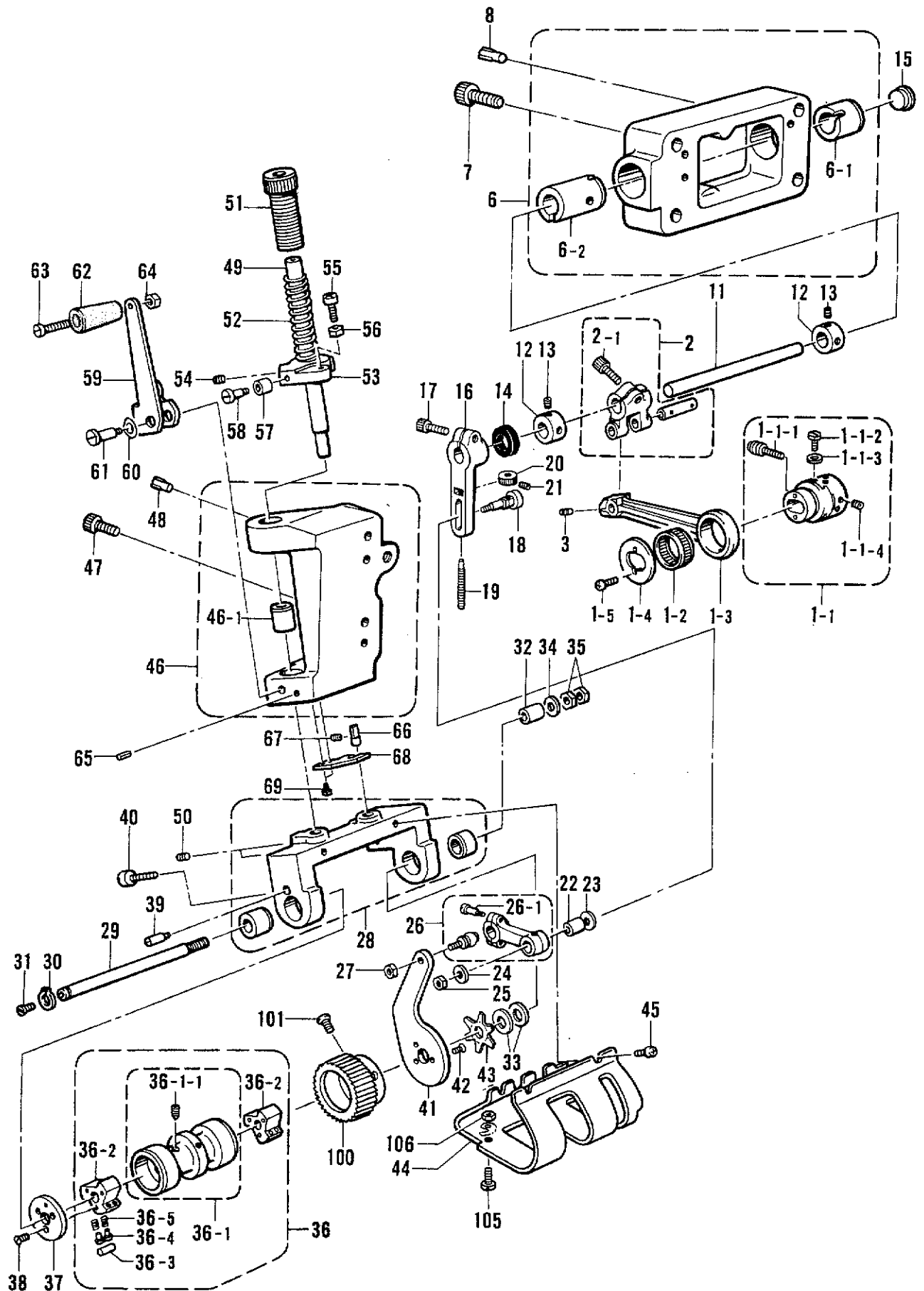

G. プーラ装置関係 / Puller device mechanism / Ziehvorrichtung / Mécanisme due puller / Mecanismo del dispositivo de arrastre

REF.NO.	CODE	Q'TY	ヒンメイ	NAME OF PARTS	RM
44	S44906001	1	プーラガード	PULLER GUARD	
45	062680612	4	ナベコ4.37-40X6	SCREW, PAN SM4.37-40X6	
46	S28261001	1	プーラブラケットLクミ	PULLER BRACKET (L) ASSY	
46-1	S12858000	1	リテーナジクメタルF	RETAINER SHAFT BUSH (F)	
47	018061622	2	アナボルト6X16	BOLT, SOCKET M6X16	
48	117608001	2	ミソツキピン	DOWEL PIN	
49	S12942001	1	プーラオサエボウ	PULLER PRESSER BAR	
50	014760622	2	アナトメネジ5.95	SET SCREW, SOCKET SM5.95	
51	S12943001	1	プーラアツチヨウセツネジ	ADJUST SCREW	
52	S28263001	1	プーラオサエバネ	PULLER SPRING	
53	S28264001	1	プーラオサエボウダキ	PULLER PRESSER BAR CLAMP	
54	014770622	1	アナトメネジ6.35クボミ	SET SCREW, SOCKET (CP) SM6.35	
55	062682012	1	ナベコ437-40X20	SCREW, PAN SM4.37-40X20	
56	105234003	1	ナツト4.37	NUT, SM4.37	
57	110167001	1	コロ	ROLLER	
58	110168001	1	コロジク	ROLLER SHAFT	
59	S12946001	1	プーラアゲレバー	PULLER LIFTING LEVER	
60	109239001	1	ナミバネザガネ	WASHER, WAVE SPRING	
61	S28333001	1	ダンネジ5.95	STUD SCREW, M5.95	
62	159093009	1	ハンドル	HANDLE	
63	112700001	1	シメネジ5.95	SCREW, SM5.95	
64	106588003	1	ナツト5.95	NUT, SM5.95	
65	047400842	1	スプリングピンAW4X8	PIN, SPRING ROLL AW4X8	
66	S28265001	1	アンナイジク	GUIDE SHAFT.	
67	014680422	1	アナトメネジ4.37クボミ	SET SCREW, SOCKET (CP) SM4.37	
68	S28266001	1	アンナイイタ	GUIDE PLATE	
69	017681012	2	ボルト4.37X10	BOLT, SM4.37X10	
100	S44907001	1	スチールギヤ65	STEAL GEAR	
101	102538002	3	サラネジ3.57	SCREW, FLAT SM3.57	
105	100257010	1	シメネジ3.57	SCREW, SM3.57	
106	021670102	1	ナツト1シユ3.57	NUT, 1 SM3.57	

H. 下軸関係 / Lower shaft mechanism / Untere Welle / Mécanisme de l'arbre inférieur / Mecanismo del eje inferior

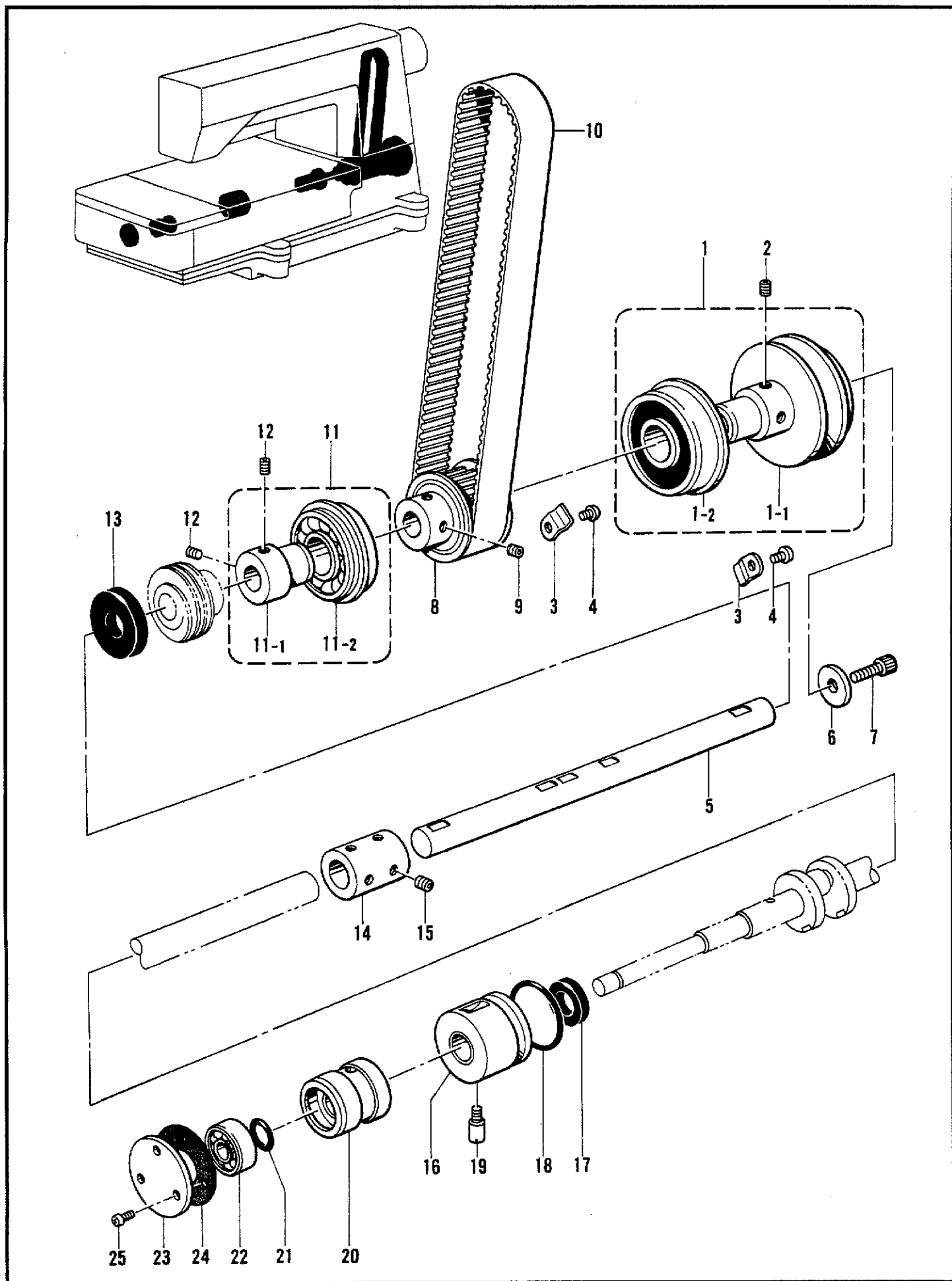

H. 下軸関係 / Lower shaft mechanism / Untere Welle / Mécanisme de l'arbre inférieur / Mecanismo del eje inferior

REF.NO.	CODE	Q'TY	ヒンメイ	NAME OF PARTS	RM
1	S08889101	1	Vベルトプーリクミ	V-BELT PULLEY ASSY	
1-1	S08890001	1	Vベルトプーリ	V-BELT PULLEY	
1-2	S14622001	1	タマジクウケ6304VV	BALL BEARING, 6304VV	
2	014780622	2	アナトメネジ6.35クボミ	SET SCREW, SOCKET (CP) SM6.35	
3	153734001	2	アームササエイタバネ	PLATE SPRING	
4	062680612	2	ナベコ4.37-40X6	SCREW, PAN SM4.37-40X6	
5	S08891001	1	シタジクR	LOWER SHAFT (R)	
6	154886001	1	ザガネ	WASHER	
7	018771432	1	アナボルト635-40X14	BOLT, SOCKET SM6.35-40X14	
8	S08892001	1	タイミングプーリDクミ	TIMING PULLEY (D) ASSY	
9	014770622	2	アナトメネジ6.35クボミ	SET SCREW, SOCKET (CP) SM6.35	
10	S08895002	1	タイミングベルト	TIMING BELT	
11	S08896101	1	タマジクウケクミ	BALL BEARING ASSY	
11-1	S08897001	1	タマジクウケブシュ	BALL BEARING BUSH	
11-2	S14623001	1	タマジクウケ6204DV	BALL BEARING, 6204DV	
12	014770622	2	アナトメネジ6.35クボミ	SET SCREW, SOCKET (CP) SM6.35	
13	S08898000	1	オイルシール	OIL SEAL	
14	S08899001	1	ジクツギテ	SHAFT JOINT	
15	014770622	4	アナトメネジ6.35クボミ	SET SCREW, SOCKET (CP) SM6.35	
16	S08900000	1	クランクジクメタルRクミ	LOWER SHAFT BUSH (R) ASSY	
17	S08903000	1	ダストシール	DUST SEAL	
18	081032870	1	OリングS32	O RING, S32	
19	S08967001	1	シメネジ4.76	SCREW, SM4.76	
20	S08904000	1	クランクジクメタルLクミ	CRANK SHAFT BUSH (L) ASSY	
21	114294001	1	Oリング	O RING	
22	072600000	1	タマジクウケ6000	BALL BEARING, 6000	
23	143311001	1	ベアリングフタ	BEARING COVER	
24	143312000	1	ベアリングフタバツキン	BEARING COVER PACKING	
25	062670812	3	ナベコ3.57-40X8	SCREW, PAN SM3.57-40X8	

J. ルーパー関係 / Looper mechanism / Greifer / Mécanisme des griffes / Mecanismo del presilladora

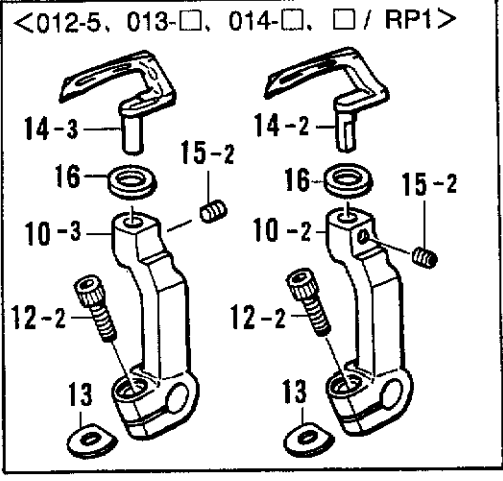
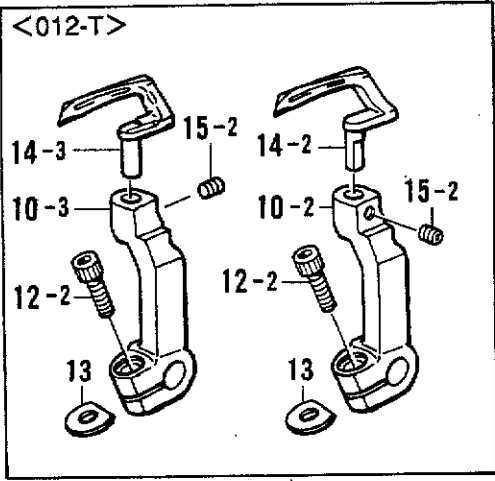
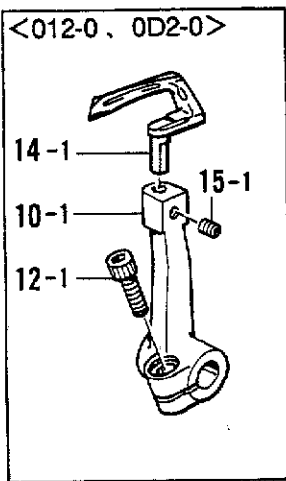
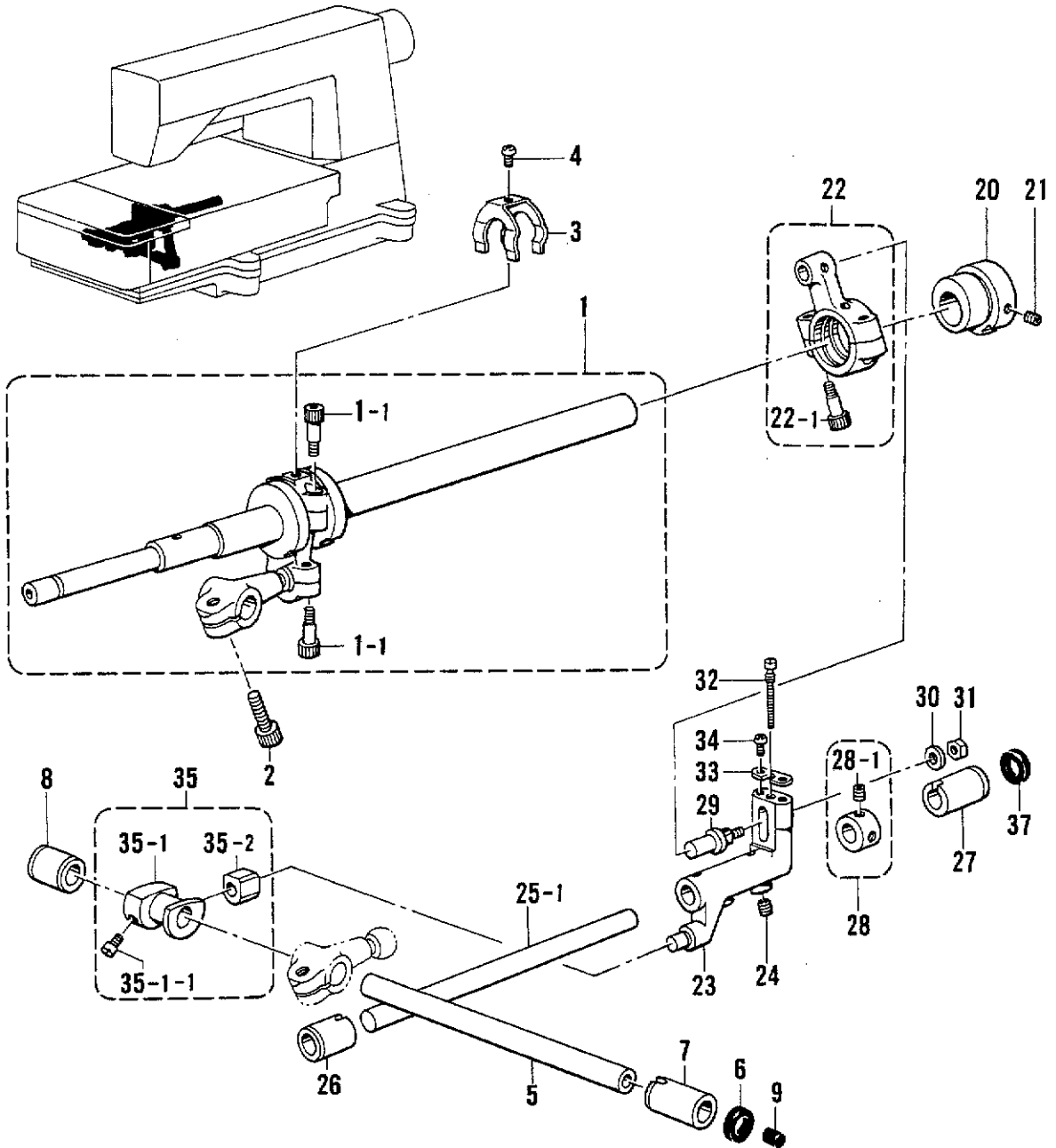

J. ルーパー関係 / Looper mechanism / Greifer / Mécanisme des griffes / Mecanismo del presilladora

REF.NO.	CODE	Q'TY	ヒンメイ	NAME OF PARTS	RM
1	S40567001	1	ルーパクランクジククミ	LOOPER CRANK SHAFT	
1-1	148425001	4	アナボルト4.37X14	BOLT, SOCKET SM4.37X14	
2	018771432	1	アナボルト635-40X14	BOLT, SOCKET SM6.35-40X14	
3	110704001	1	ウワルーパロツドフレドメ	LOOPER CONNECTING ROD STOPPER	
4	062660412	1	ナベコ318-40X4	SCREW, PAN SM3.18-40X4	
5	S40977001	1	ルーパジク	LOOPER SHAFT	
6	155539000	1	ダストシール	DUST SEAL	
7	S08770000	1	ジクメタル	SHAFT BUSH	
8	S08911000	1	ルーパジクメタルB	LOOPER SHAFT BUSHING (B)	
9	140327001	1	ゴムセン6.3	RUBBER CAP, 6.3	
20	S08914001	1	ゼンゴヘンシンリン	LONGITUDINAL ECCENTRIC CAM	
21	014680622	2	アナトメネジ4.37クボミ	SET SCREW, SOCKET (CP) SM4.37	
22	146624101	1	ゼンゴロツドクミ	LONGITUDINAL FEED ROD ASSY	
22-1	148425001	2	アナボルト4.37X14	BOLT, SOCKET SM4.37X14	
23	S08915001	1	ゼンゴレバー	LONGITUDINAL LEVER	
24	014770622	2	アナトメネジ6.35クボミ	SET SCREW, SOCKET (CP) SM6.35	
25-1	S11588001	1	ゼンゴレバージク	LONGITUDINAL FEED SHAFT	
26	S08917000	1	レバージクメタルL	LONGITUDINAL FEED SHAFT BUSH (L)	
27	S08754000	1	ハリウケBジクメタルR	KNIFE DRIVING SHAFT BUSH (R)	
28	S03704002	1	セツトカラークミ	SET SCREW COLLAR ASSY	
28-1	014770622	2	アナトメネジ6.35クボミ	SET SCREW, SOCKET (CP) SM6.35	
29	S08918001	1	ゼンゴロツドピン	PIN	
30	148847001	1	ザガネ	WASHER, PLAIN 4.76	
31	110161006	1	ナツト4.76	NUT, SM4.76	
32	S08919001	1	ヘンシンチヨウセツネジ	ADJUST SCREW	
33	S08920001	1	ヘンシントメイタ	ECCENTRIC WHEEL STOPPER PLATE	
34	062630612	2	ナベコ238-56X6	SCREW, PAN SM2.38-56X6	
35	S08921101	1	ゼンゴコマクミ	LONGITUDINAL BLOCK ASSY	
35-1	S09251001	1	ゼンゴコマネジツキ	LONGITUDINAL BLOCK WITH SCREW	
35-1-1	120990001	2	アタマツキトメネジ4.37	SET SCREW, SM4.37	
35-2	140313001	1	ゼンゴレバーカクゴマ	LONGITUDINAL FEED LEVER SLIDE BLOCK	
37	S11589000	1	ダストシール	DUST SEAL	
<0D2-0,012-0>					
10-1	S08912001	1	ルーパホルダ	LOOPER HOLDER	
12-1	018771432	1	アナボルト635-40X14	BOLT, SOCKET SM6.35-40X14	
14-1	S40569001	1	ルーパ	LOOPER	
15-1	014680422	1	アナトメネジ4.37クボミ	SET SCREW, SOCKET (CP) SM4.37	
<012-T>					
10-2	S40976001	1	ルーパホルダL	LOOPER HOLDER L	
10-3	S40975001	1	ルーパホルダR	LOOPER HOLDER R	
12-2	018771432	2	アナボルト635-40X14	BOLT, SOCKET SM6.35-40X14	
13	155162001	2	スベーサ	SPACER	
14-2	S40973001	1	ルーパL	LOOPER L	
14-3	S40974001	1	ルーパR	LOOPER R	
15-2	014680422	2	アナトメネジ4.37クボミ	SET SCREW, SOCKET (CP) SM4.37	
<012-5,013-□,014-□, □/RP1>					
10-2	S40976001	1	ルーパホルダL	LOOPER HOLDER L	
10-3	S40975001	1	ルーパホルダR	LOOPER HOLDER R	
12-2	018771432	2	アナボルト635-40X14	BOLT, SOCKET SM6.35-40X14	
13	155162001	2	スベーサ	SPACER	
14-2	S40973001	1	ルーパL	LOOPER L	
14-3	S40974001	1	ルーパR	LOOPER R	
15-2	014680422	2	アナトメネジ4.37クボミ	SET SCREW, SOCKET (CP) SM4.37	
16	S40996001	2	カンザ	WASHER	

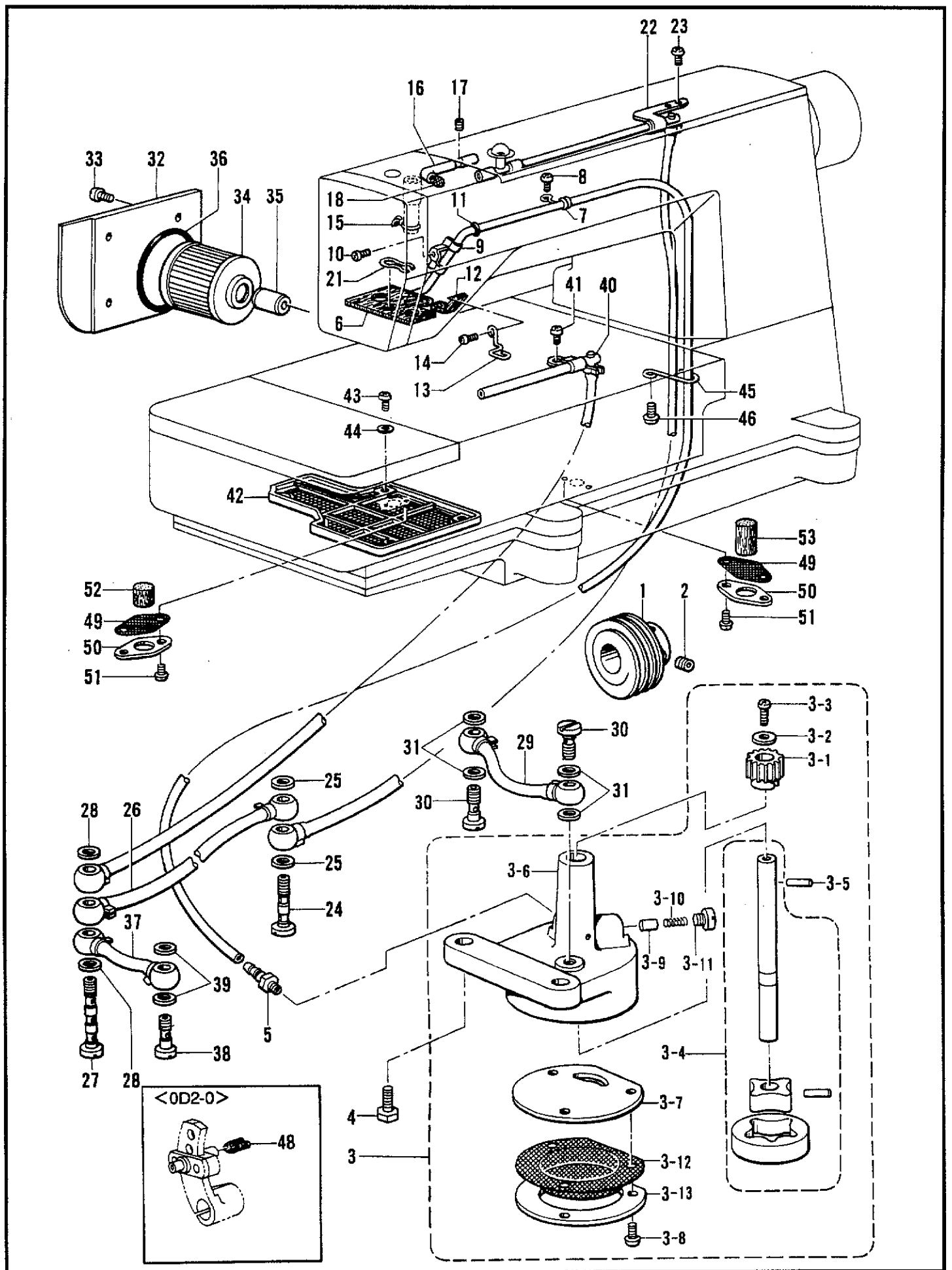

K. 給油潤滑関係 / Lubrication / Schmierung / Lubrification / Lubricación

REF.NO.	CODE	Q'TY	ヒンメイ	NAME OF PARTS	RM
1	S08935001	1	ウオーム	WORM	
2	014770622	2	アナトメネジ6.35クボミ	SET SCREW, SOCKET (CP) SM6.35	
3	S08936201	1	トロコイドポンプクミ	PUMP ASSY	
3-1	144619000	1	ウオームホイール	WORM WHEEL	
3-2	025350332	1	ヒラザガネダイ3.5	WASHER, PLAIN L 3.5	
3-3	062670812	1	ナベコ3.57-40X8	SCREW, PAN SM3.57-40X8	
3-4	S08937101	1	ポンプロータークミ	PUMP INNER ROTER ASSY	
3-5	144622001	1	ミゾツキピンEガタ	DOWEL PIN (E)	
3-6	S08939100	1	ポンプケース	PUMP CASE	
3-7	147527000	1	ポンプフタ	PUMP COVER	
3-8	062671012	3	ナベコ357-40X10	SCREW, PAN SM3.57-40X10	
3-9	144875001	1	プランジヤー	PLUNGER	
3-10	144876001	1	プランジヤーバネ	SPRING	
3-11	112467002	1	シメネジ6.35	SCREW, SM6.35	
3-12	147528100	1	ロカモウ	OIL FILTER	
3-13	147529000	1	ロカモウオサエ	OIL FILTER FLANGE	
4	017781412	2	ボルト6.35X14	BOLT, SM6.35X14	
5	142359001	1	オイルクチ	OIL FEEDING PIPE	
6	S08940000	1	チューブクミ	OIL TUBE ASSY	
7	112743001	1	クミヒモササエ	WICK SUPPORT	
8	062670612	1	ナベコ357-40X6	SCREW, PAN SM3.57-40X6	
9	151429001	1	チューブホルダ	TUBE HOLDER	
10	062670612	1	ナベコ357-40X6	SCREW, PAN SM3.57-40X6	
11	118770001	1	パツキン	PACKING	
12	S08943000	1	カクゴマフェルト	FELT	
13	S08944001	1	フェルトオサエ	FELT SUPPORT	
14	062670612	1	ナベコ357-40X6	SCREW, PAN SM3.57-40X6	
15	157840000	1	クミヒモ3X3	WICK, 3X3 (L = 100)	
16	S08945001	1	オイルパイプ	OIL PIPE	
17	014680622	1	アナトメネジ4.37クボミ	SET SCREW, SOCKET (CP) SM4.37	
18	S08946000	1	フェルト	FELT	
21	145737001	1	フェルトオサエ	FELT SUPPORT	
22	S08948001	1	ロツドオイルパイプUクミ	MAIN OIL PIPE (U) ASSY	
23	062670612	2	ナベコ357-40X6	SCREW, PAN SM3.57-40X6	
24	112364001	1	ハイユパイプツギテネジ	OIL FEEDING PIPE JOINT SCREW	
25	159476000	2	ザガネ	WASHER	
26	S08951001	1	ビニルチューブクミ	OIL TUBE ASSY	
27	112351001	1	ハイユパイプネジ	OIL FEEDING PIPE SCREW	
28	159476000	2	ザガネ	WASHER	
29	155282101	1	ビニルチューブクミ	OIL TUBE ASSY	
30	112359052	2	ハイユパイプツギテネジ		
31	159476000	4	ザガネ	WASHER	
32	S08955051	1	オイルフィルターフタ		
33	062680812	4	ナベコ437-40X8	SCREW, PAN SM4.37-40X8	
34	S08956100	1	オイルフィルター		
35	S08957001	1	オイルクチ	OIL FEEDING PIPE	
36	081044070	1	OリングP44	O RING, P44	
37	S08953001	1	ビニルチューブクミ	OIL TUBE ASSMBLY	
38	112359052	1	ハイユパイプツギテネジ		
39	159476000	2	ザガネ	WASHER	
40	S08958001	1	ロツドオイルパイプDクミ	MAIN OIL PIPE (D) ASSY	
41	062670612	1	ナベコ357-40X6	SCREW, PAN SM3.57-40X6	
42	S09316000	1	オイルフィルターD	OIL FILTE (D)	
43	062680812	4	ナベコ437-40X8	SCREW, PAN SM4.37-40X8	
44	100645003	4	ザガネ	WASHER	
45	S09125001	1	チューブガイド	OIL TUBE GUIDE	
46	062780812	1	ナベコ635-28X8	SCREW, PAN SM6.35-28X8	
49	155294100	2	ロカモウ	OIL FILTER	
50	155295001	2	ロカモウオサエイタ	OIL FILTER FLANGE	
51	062670612	4	ナベコ357-40X6	SCREW, PAN SM3.57-40X6	
52	151927001	1	クラッチフェルト	CLUTCH FELT	
53	112754001	1	フェルト	FELT	
48	147363000	1	<0D2-0> フェルト	<0D2-0> FELT	





L. 糸調子関係 / Thread tension / Faderspannung / Tension du fil / Tensión del hilo

REF.NO.	CODE	Q'TY	ヒンメイ	NAME OF PARTS	RM
1	S08961101	1	シユイトアンナイ	MAIN THREAD GUIDE	
2	062680812	2	ナベコ437-40X8	SCREW, PAN SM4.37-40X8	
4	150645009	1	イトアンナイパイプL	THREAD GUIDE PIPE, L	
6	014680422	1	アナトメネジ4.37クボミ	SET SCREW, SOCKET (CP) SM4.37	
7	S08962109	1	イトチヨウシダイ	TENSION BRACKET	
8	062681012	2	ナベコ437-40X10	SCREW, PAN SM4.37-40X10	
27	S08965009	1	イトユルメイタ	TENSION RELEASE PLATE	
28	S08966001	1	イトユルメジク	TENSION RELEASE SHAFT	
29	S08967001	2	シメネジ4.76	SCREW, SM4.76	
30	118718001	1	オサエボウダキオシバナ	SPRING, COMPRESSION	
31	S08968001	1	イトユルメウデ	TENSION RELEASE ARM	
32	062681212	1	ナベコ437-40X12	SCREW, PAN SM4.37-40X12	
39	100645003	1	ザガネ	WASHER	
40	S08969201	1	チユウカンイトアンナイ	THREAD GUIDE	
41	018680822	1	アナボルト4.37X8	BOLT, SOCKET SM4.37X8	
42	143602001	1	ミゾツキピン	DOWEL PIN	
45	S08971201	1	ハライトクリヘンシンリンクミ	NEEDLE THREAD TAKE-UP ECCENTRIC ASSY	
45-1	014770622	2	アナトメネジ6.35クボミ	SET SCREW, SOCKET (CP) SM6.35	
45-2	018401422	2	アナボルト4X14	BOLT, SOCKET M4X14	
47	018771432	1	アナボルト635-40X14	BOLT, SOCKET SM6.35-40X14	
48	155220000	1	ホジヨアツメタルR	AUTO PRESSER ARM BUSH (R)	
49	S08770000	1	ジクメタル	SHAFT BUSH	
50	S08976001	1	ハライトクリジク	NEEDLE THREAD TAKE-UP SHAFT	
51	S00356001	1	ザガネ	WASHER	
52	S00383001	1	ボルト5.56X8	BOLT, M5.56X8	
53	155539000	1	ダストシール	DUST SEAL	
54	S08977001	1	ハライトクリレバー	NEEDLE THREAD TAKE-UP LEVER	
55	018771432	1	アナボルト635-40X14	BOLT, SOCKET SM6.35-40X14	
56	155162001	1	スペーサ	SPACER	
57	S08978001	1	ハライトクリ	NEEDLE THREAD TAKE-UP	
58	062681012	2	ナベコ437-40X10	SCREW, PAN SM4.37-40X10	
59	100645003	2	ザガネ	WASHER	
68	S08981001	1	ハリボウテンピン	NEEDLE BAR TAKE-UP	
69	062670612	1	ナベコ357-40X6	SCREW, PAN SM3.57-40X6	
71	014680422	1	アナトメネジ4.37クボミ	SET SCREW, SOCKET (CP) SM4.37	
72	S08983001	1	アームハライトウケ	ARM NEEDLE THREAD GUIDE	
73-1	S28438001	1	アームイトアンナイD	ARM THREAD GUIDE (D)	
74	062680812	1	ナベコ437-40X8	SCREW, PAN SM4.37-40X8	
92	062680612	1	ナベコ4.37-40X6	SCREW, PAN SM4.37-40X6	
94	S18530001	1	テンビンドダイDクミ	LOOPER THREAD TAKE-UP BASE (D) ASSY	
95	060680712	2	バインド437-40X7	SCREW, BIND SM4.37-40X7	
96	S18532001	1	テンビンドダイUクミ	LOOPER THREAD TAKE-UP BASE (U) ASSY	
96-1	146924000	1	スレツドブツシユ	THREAD BUSH	
97	018680822	2	アナボルト4.37X8	BOLT, SOCKET SM4.37X8	
98	S18534001	1	ドダイオサエバナ	SPRING	
99	062670512	1	ナベコ357-40X5	SCREW, PAN SM3.57-40X5	
100	S18535001	1	イトオサエドダイ	THREAD PRESSER BASE	
101	154965001	1	アナボルト3.57X8	BOLT, SOCKET SM3.57X8	
102	S08992001	1	テンピンイトオサエ	LOOPER TAKE-UP PRESSER	
103	154965001	1	アナボルト3.57X8	BOLT, SOCKET SM3.57X8	
104	S08987001	1	イトチヨウシボウ	THREAD TENSION CONTROL STUD	
105	144504001	2	イトアンナイサラ	THREAD GUIDE DISC	
106	144505000	1	イトアンナイバナ	SPRING	
107	155510001	1	イトチヨウシナツト	TENSION NUT	
108	S08993101	1	テンピンイトウケ	TAKE-UP THREAD GUIDE	
109	062670512	1	ナベコ357-40X5	SCREW, PAN SM3.57-40X5	
110	105161004	1	ザガネ	WASHER	
111	S08994001	2	テンピンイトアンナイ	THREAD GUIDE	
112	060660416	2	バインド318-40X4	SCREW, BIND SM3.18-40X4	
114	144075001	1	ボルト3.57	BOLT, SM3.57	
115	105161004	1	ザガネ	WASHER	
116	S40572001	1	シタイトテンピンクミ	LOOPER THREAD TAKE-UP ASSY	
117	014680422	2	アナトメネジ4.37クボミ	SET SCREW, SOCKET (CP) SM4.37	
120	S40570001	1	イトアンナイDダイ	THREAD GUIDE BRACKET	
121	060670812	2	バインド357-40X8	SCREW, BIND SM3.57-40X8	
126	062670512	1	ナベコ357-40X5	SCREW, PAN SM3.57-40X5	
127	105161004	1	ザガネ	WASHER	
128	S12882001	1	イトアンナイ	THREAD GUIDE	
129	S25818051	1	チヨウセツレバーストツバ	AJUST LEVER STOPPER	
130	062350612	1	ナベコM3.5X6	SCREW, PAN M3.5X6	

<012-0, 0D2-0>

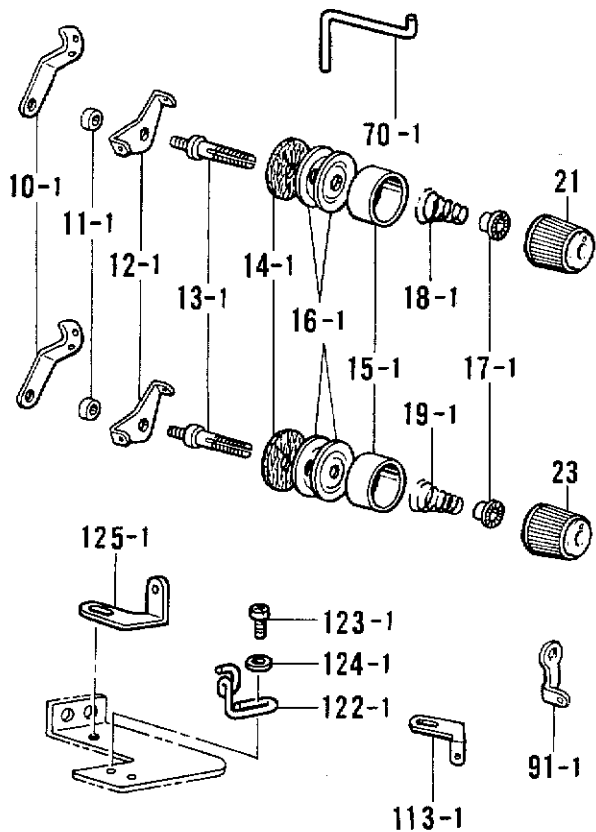

<012-T>

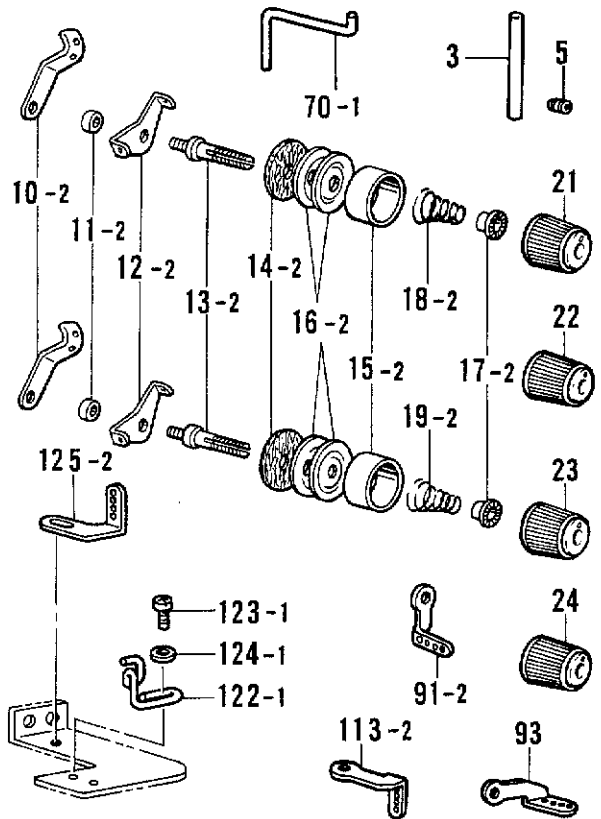

<012-5, 013-□, 014-□, □ / RP1>

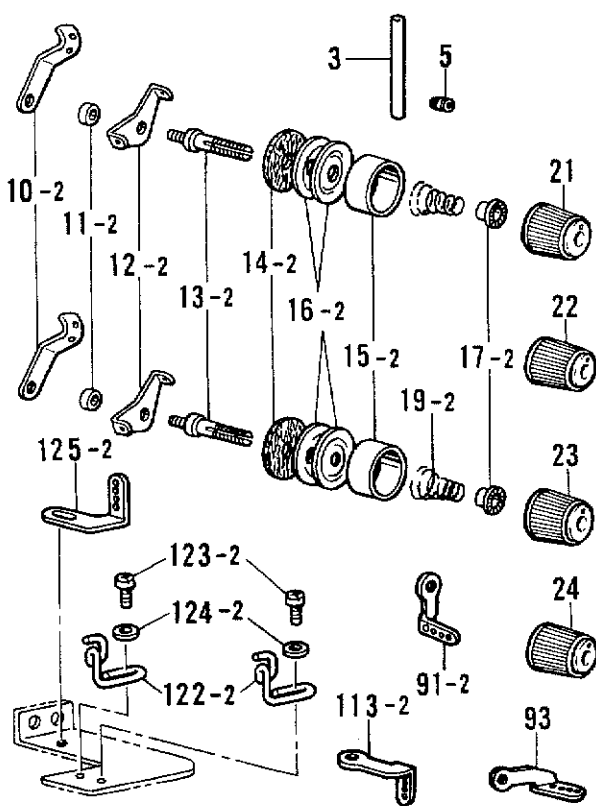

<オプションパーツ / OPTION PARTS>

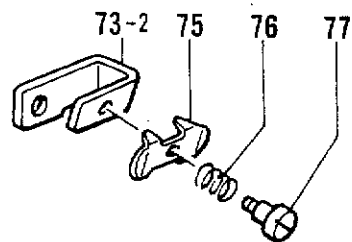

<012-5>

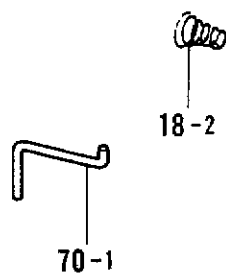

<013-□, 014-□, □ / RP1>

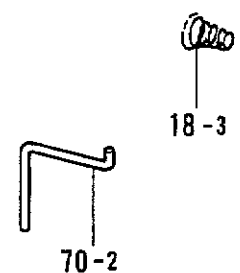

L. 糸調子関係 / Thread tension / Faderspannung / Tension du fil / Tensión del hilo

REF.NO.	CODE	Q'TY	ヒンメイ	NAME OF PARTS	RM
			<b>&lt;0D2-0,012-0&gt;</b>	<b>&lt;0D2-0,012-0&gt;</b>	
10-1	508963001	2	イトチヨウシダイイトアンナイ	TENSION BRACKET THREAD GUIDE	
11-1	508964001	2	カンザ	SPACER	
12-1	110813001	2	ハリイトアンナイ	NEEDLE THREAD GUIDE	
13-1	159574101	2	イトチヨウシボウ	TENSION STUD	
14-1	110832009	2	イトチヨウシサラフェルト	TENSION DISC FELT	
15-1	144103009	2	イトチヨウシサラオサエ	TENSION DISC PRESSER	
16-1	145446001	4	イトチヨウシサラ	TENSION DISC	
17-1	S30564000	2	チヨウシバネウエザガネ	TENSION SPRING WASHER	
18-1	144104001	1	ハリイトチヨウシバネ	THREAD TENSION ADJUST SPRING	
19-1	144110001	1	シタルーパイトチヨウシバネ	THREAD TENSION ADJUST SPRING	
21	S30565003	1	イトチヨウシナツト	TENSION NUT, RED	
23	S30565003	1	イトチヨウシナツト	TENSION NUT, RED	
70-1	S08982001	1	ハリイトウケ	NEEDLE THREAD GUIDE	
91-1	S08970001	1	イトアンナイS	THREAD GUIDE, S	
113-1	155313001	1	ウワルーパイトアンナイ	LOOPER THREAD GUIDE	
122-1	S40571001	1	シタイトアンナイF	LOWER THREAD GUIDE (F)	
123-1	062670612	1	ナベコ357-40X6	SCREW, PAN SM3.57-40X6	
124-1	105161004	1	ザガネ	WASHER	
125-1	155313001	1	ウワルーパイトアンナイ	LOOPER THREAD GUIDE	
			<b>&lt;012-5,013-□,014-□, □/RP1&gt;</b>	<b>&lt;012-5,013-□,014-□,□/RP1&gt;</b>	
3	150644009	1	イトアンナイパイプS	THREAD GUIDE PIPE (S)	
5	014680422	1	アナトメネジ4.37クボミ	SET SCREW, SOCKET (CP) SM4.37	
10-2	S08963001	4	イトチヨウシダイイトアンナイ	TENSION BRACKET THREAD GUIDE	
11-2	S08964001	4	カンザ	SPACER	
12-2	110813001	4	ハリイトアンナイ	NEEDLE THREAD GUIDE	
13-2	159574101	4	イトチヨウシボウ	TENSION STUD	
14-2	110832009	4	イトチヨウシサラフェルト	TENSION DISC FELT	
15-2	144103009	4	イトチヨウシサラオサエ	TENSION DISC PRESSER	
16-2	145446001	8	イトチヨウシサラ	TENSION DISC	
17-2	S30564000	4	チヨウシバネウエザガネ	TENSION SPRING WASHER	
19-2	144110001	2	シタルーパイトチヨウシバネ	THREAD TENSION ADJUST SPRING	
21	S30565003	1	イトチヨウシナツト	TENSION NUT, RED	
22	S30565002	1	イトチヨウシナツト	TENSION NUT, GREEN	
23	S30565003	1	イトチヨウシナツト	TENSION NUT, RED	
24	S30565002	1	イトチヨウシナツト	TENSION NUT, GREEN	
91-2	S12882001	1	イトアンナイ	THREAD GUIDE	
93	S12882001	1	イトアンナイ	THREAD GUIDE	
113-2	S12882001	1	イトアンナイ	THREAD GUIDE	
122-2	S40571001	2	シタイトアンナイF	LOWER THREAD GUIDE (F)	
123-2	062670612	2	ナベコ357-40X6	SCREW, PAN SM3.57-40X6	
124-2	105161004	2	ザガネ	WASHER	
125-2	S12882001	1	イトアンナイ	THREAD GUIDE	
70-1	S08982001	1	ハリイトウケ	NEEDLE THREAD GUIDE	
18-2	144104001	2	ハリイトチヨウシバネ	THREAD TENSION ADJUST SPRING	
70-2	S44911001	1	ハリイトウケ	NEEDLE THREAD GUIDE	
18-3	148851001	2	ハリイトチヨウシバネ	THREAD TENSION ADJUST SPRING	
			<b>&lt;012-T&gt;</b>	<b>&lt;012-T&gt;</b>	
3	150644009	1	イトアンナイパイプS	THREAD GUIDE PIPE (S)	
5	014680422	1	アナトメネジ4.37クボミ	SET SCREW, SOCKET (CP) SM4.37	
10-2	S08963001	4	イトチヨウシダイイトアンナイ	TENSION BRACKET THREAD GUIDE	
11-2	S08964001	4	カンザ	SPACER	
12-2	110813001	4	ハリイトアンナイ	NEEDLE THREAD GUIDE	
13-2	159574101	4	イトチヨウシボウ	TENSION STUD	
14-2	110832009	4	イトチヨウシサラフェルト	TENSION DISC FELT	

<012-0. 0D2-0>

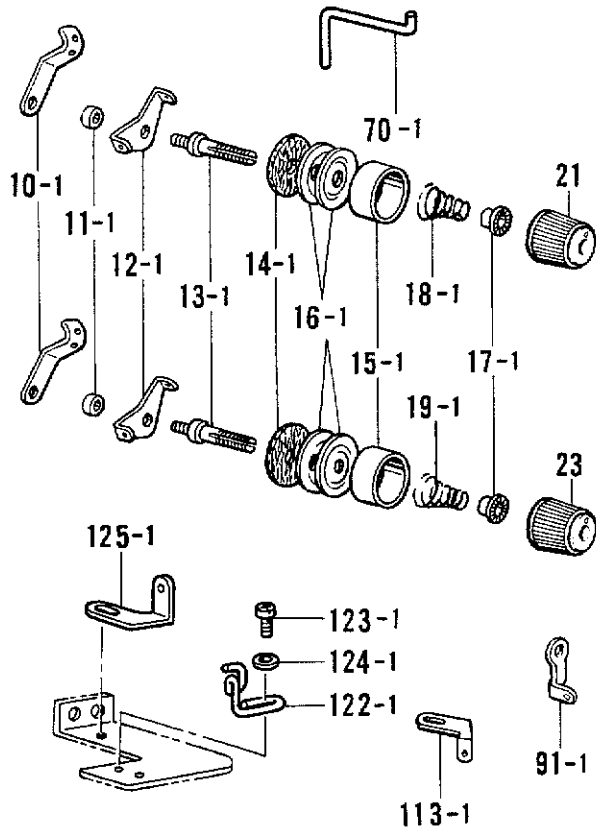

<012-T>

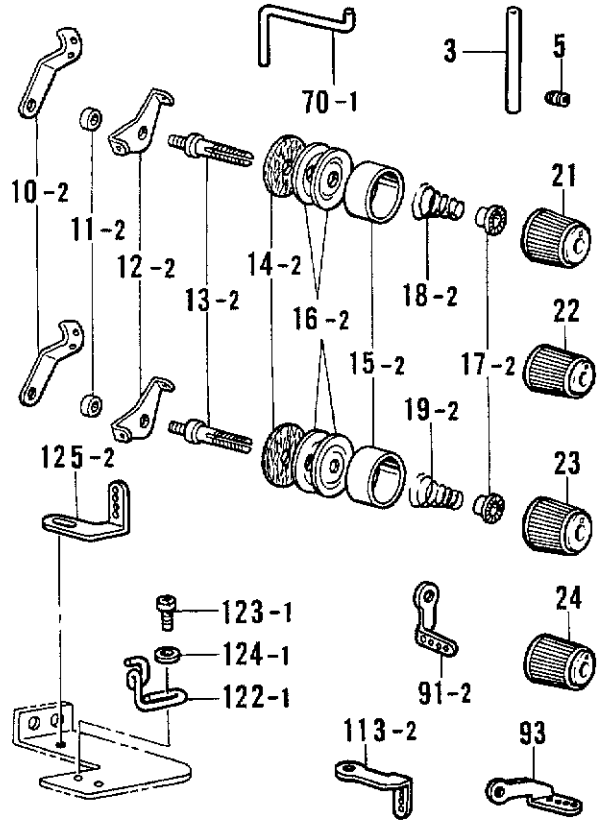

<012-5. 013-□. 014-□. □ / RP1>

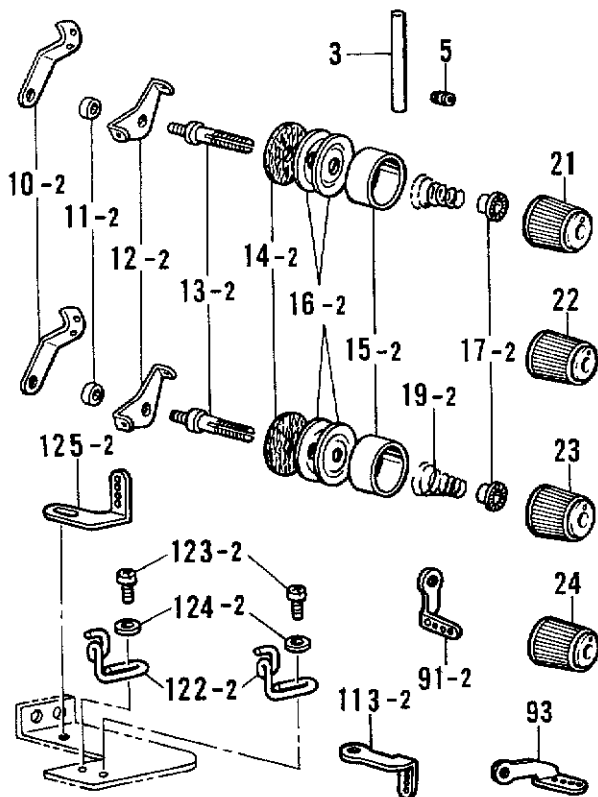

<オプションパーツ / OPTION PARTS>

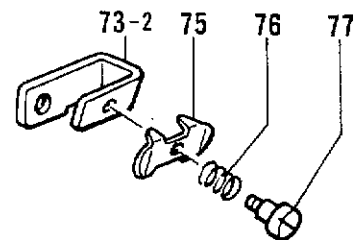

<012-5>

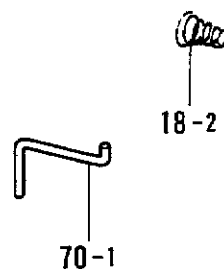

<013-□. 014-□. □ / RP1>

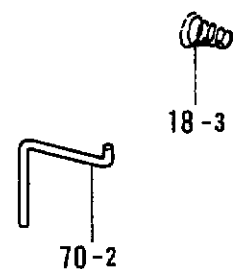

L. 糸調子関係 / Thread tension / Faderspannung / Tension du fil / Tensión del hilo

REF.NO.	CODE	Q'TY	ヒンメイ	NAME OF PARTS	RM
15-2	144103009	4	イトチヨウシサラオサエ	TENSION DISC PRESSER	
16-2	145446001	8	イトチヨウシサラ	TENSION DISC	
17-2	S30564000	4	チヨウシバネウエザガネ	TENSION SPRING WASHER	
18-2	144104001	2	ハライトチヨウシバネ	THREAD TENSION ADJUST SPRING	
19-2	144110001	2	シタルーパイトチヨウシバネ	THREAD TENSION ADJUST SPRING	
21	S30565003	1	イトチヨウシナツト	TENSION NUT, RED	
22	S30565002	1	イトチヨウシナツト	TENSION NUT, GREEN	
23	S30565003	1	イトチヨウシナツト	TENSION NUT, RED	
24	S30565002	1	イトチヨウシナツト	TENSION NUT, GREEN	
70-1	S08982001	1	ハライトウケ	NEEDLE THREAD GUIDE	
91-2	S12882001	1	イトアンナイ	THREAD GUIDE	
93	S12882001	1	イトアンナイ	THREAD GUIDE	
113-2	S12882001	1	イトアンナイ	THREAD GUIDE	
122-1	S40571001	1	シタイトアンナイF	LOWER THREAD GUIDE (F)	
123-1	062670612	1	ナベコ357-40X6	SCREW, PAN SM3.57-40X6	
124-1	105161004	1	ザガネ	WASHER	
125-2	S12882001	1	イトアンナイ	THREAD GUIDE	
73-2	S08984001	1	<オプションパーツ> サブテンションドダイ	<OPTION PARTS> SUB TENSION BASE	
75	112300001	1	ハライトオサエ	NEEDLE THREAD CLAMP	
76	112299001	1	ハライトアンナイオシバネ	COIL SPRING	
77	112301001	1	ダンネジ3.18	SHOULDER SCREW, M3.18	

Z. 付属品関係 / Accessories / Zubehör / Accessoires / Accesorios

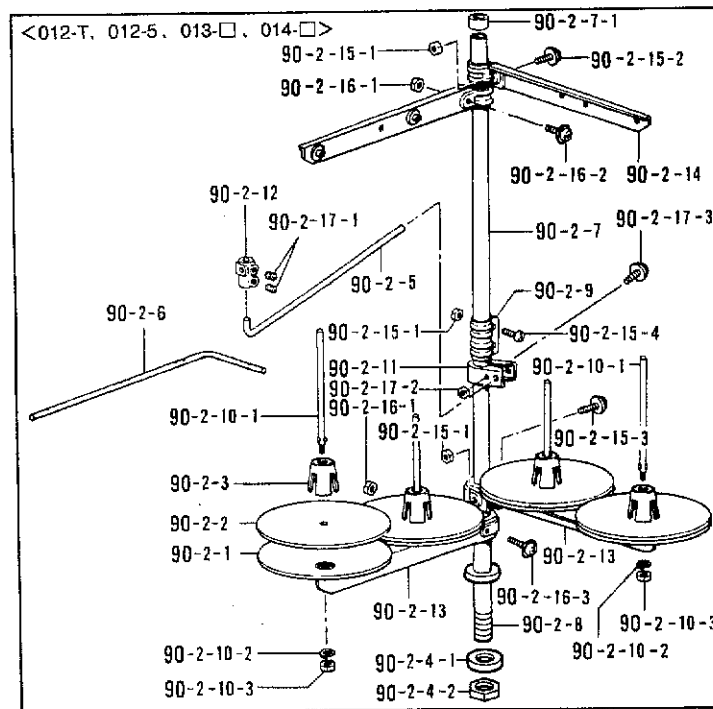
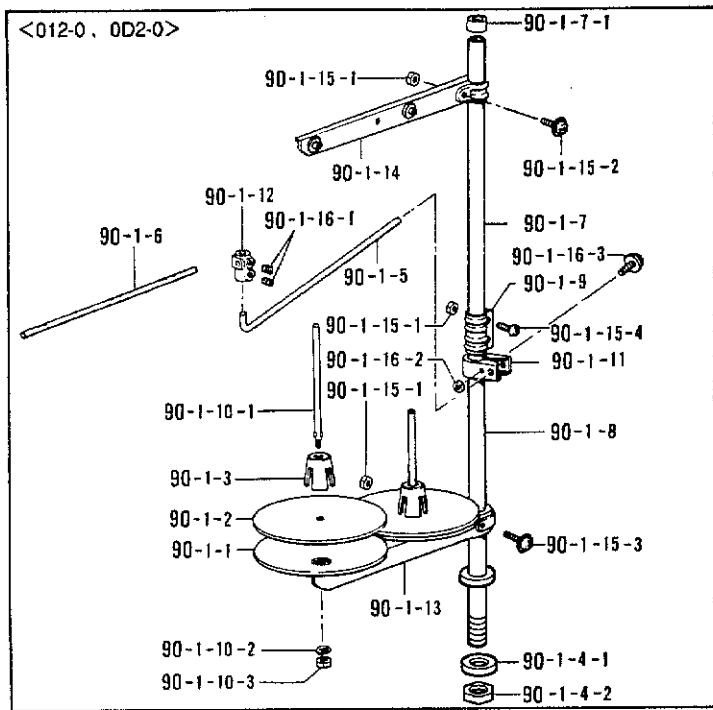
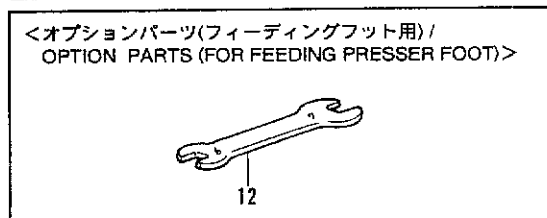
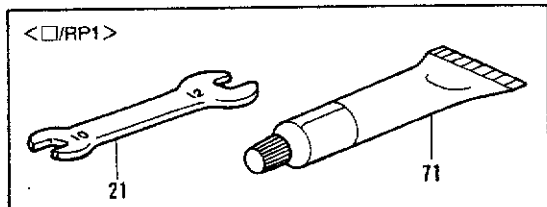
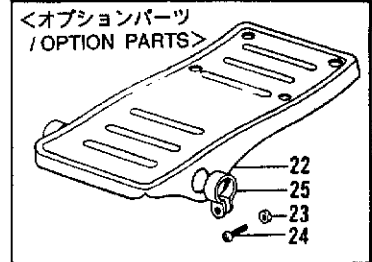
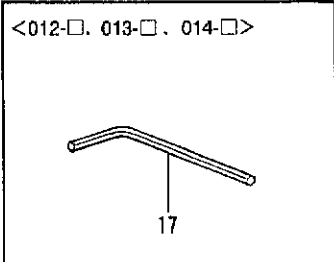
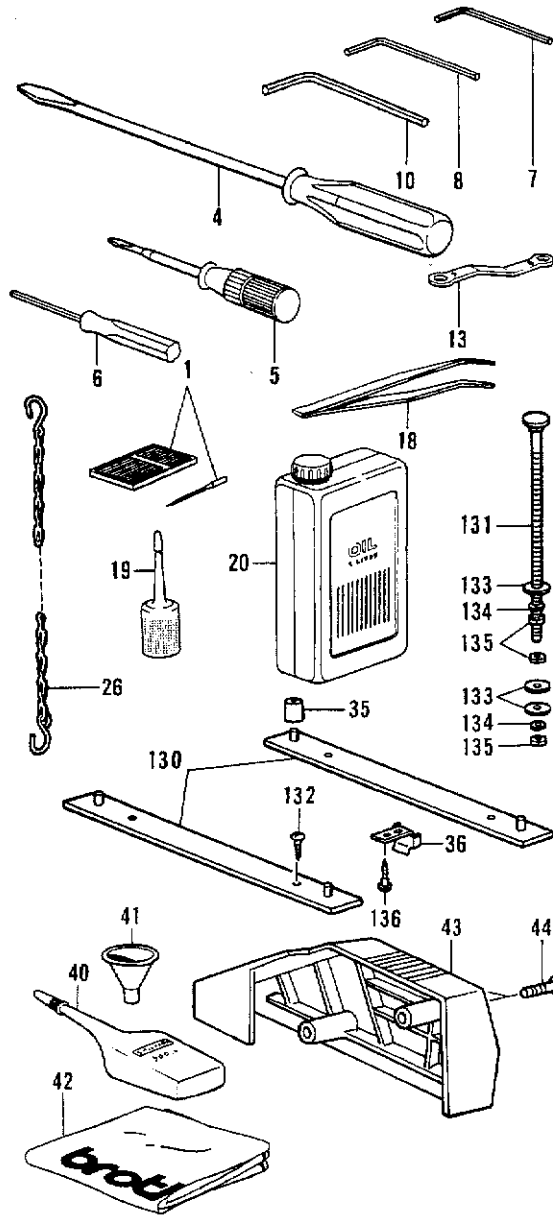

- ◎ 付属品の明細は変更することがあります。
- ◎ The details of included accessories are subject to change.
- ◎ Änderungen in der Aufstellung der Mitgelieferten Zubehöre sind vorbehalten.
- ◎ Les détails des accessoires inclus sont sujets à des changements.
- ◎ Los detalles de los accesorios incluidos pueden variar.

Z. 付属品関係 / Accessories / Zubehör / Accessoires / Accesorios

REF.NO.	CODE	Q'TY	ヒンメイ	NAME OF PARTS	RM
4	101572101	1	ネジマワシ5.5X190	SCREW DRIVER, 5.5X190	
5	118837001	1	ネジマワシ3.4X70	SCREW DRIVER, 3.4X70	
6	S01943001	1	6カクボウネジマワシ1.6	SCREW DRIVER, 1.6	
7	146049001	1	6カクボウスパナ2	HEXAGONAL WRENCH, 2	
8	142721001	1	6カクボウスパナ3	HEXAGONAL WRENCH, 3	
10	150335001	1	6カクボウスパナ5	HEXAGONAL WRENCH, 5	
13	105343001	1	メガネレンチ8X9	WRENCH, 8X9	
18	117466000	1	ピンセット	PINCETTE	
19	S06701000	1	ポリオイラークミ	POLY OILER ASSY	
20	145277205	1	オイルタンク	OIL TANK	
26	149247001	1	クサリクミ	CHAIN ASSY	
35	147919051	4	ボウシンゴム	RUBBER CUSHION	
36	S09001101	1	クサリガイド	CHAIN GUIDE	
40	S06704001	1	シリコンオイル	SILICONE OIL	
41	140759000	1	ジョーゴ	FUNNEL	
42	144224001	1	トウブカバー	HEAD COVER	
43	S09002009	1	ベルトカバー	BELT COVER	
44	102424004	2	シメネジ4.37	SCREW, M4.37	
130	S11561001	2	トウブウケイタ	HEAD SPOOL PLATE	
131	S11562001	4	カクネマルアタマボルト	BOLT	
132	100666002	4	マルモクネジ5.5X20	WOOD SCREW, ROUND M5.5X20	
133	025080336	12	ヒラザガネダイ8	WASHER, PLAIN L 8	
134	028080242	8	バネザガネ2-8	WASHER, SPRING 2-8	
135	021080106	12	ナット1シユ8	NUT, 1 M8	
136	032461606	2	+マルモクネジ4.5X16	WOOD SCREW, ROUND M4.5X16	
			<0D2-0,012-0>	<0D2-0,012-0>	
90-1	S40574009	1	イトタテダイクミ2DTHF	COTTON STAND ASSY, 2DTHF	
90-1-1	150180001	2	ウケザラ	SPOOL STAND BASE	
90-1-2	150182000	2	スプールマット	SPOOL MAT	
90-1-3	126863001	2	スプールクッション	SPOOL CUSHION	
90-1-4	S02775001	1	パイプネジセットA	PIPE SCREW SET, A	
90-1-4-1	150206002	1	ヒラザガネ16	WASHER, PLAIN 16	
90-1-4-2	S38648001	1	6カクナットU5/8	NUT, U5/8-28	
90-1-5	S04109001	1	イトアンナイサエボウ	THREAD GUIDE SUPPORT BAR	
90-1-6	142997001	1	イトアンナイ3	THREAD GUIDE, 3	
90-1-7	S40640001	1	コラムパイプキャップツキ	COLUMN PIPE WITH CAP	
90-1-7-1	150174000	1	コラムキャップ	COLUMN CAP	
90-1-8	156112003	1	コラムパイプD	COLUMN PIPE, D	
90-1-9	150173003	1	コラムジョイント	COLUMN JOINT	
90-1-10	S21798001	2	スプールネジセット	SPOOL SCREW SET	
90-1-10-1	150179002	2	スプールジクB	SPOOL SHAFT, B	
90-1-10-2	028050246	2	バネザガネ2-5	WASHER, SPRING 2-5	
90-1-10-3	021500106	2	1シユナット5	NUT, 1 M5	
90-1-11	150185009	1	イトアンナイホルダー	THREAD GUIDE HOLDER	
90-1-12	138843001	1	ササエボウツギテ	JOINT	
90-1-13	S02778002	1	スプールホルダー2	SPOOL HOLDER, 2	
90-1-14	S02786002	1	スレッドハンガークミ2	THREAD HANGER ASSY, 2	
90-1-15	S40641001	1	スプールジクネジセットA	SPOOL SCREW SET, A	
90-1-15-1	021500106	4	1シユナット5	NUT, 1 M5	
90-1-15-2	S37038001	1	ナベコヒラザ5X14	SCREW, PAN (P WASHER) M5X14	
90-1-15-3	S37037001	1	ナベコヒラザ5X32	SCREW, PAN (P WASHER) M5X32	
90-1-15-4	062501406	2	ナベコ5X14	SCREW, PAN M5X14	
90-1-16	S40643001	1	ホルダーツギテネジセット	HOLDER JOINT SCREW SET	
90-1-16-1	014060632	2	アナトメ6X6クボミ	SET SCREW, SOCKET (CP) M6X6	
90-1-16-2	021500106	1	1シユナット5	NUT, 1 M5	
90-1-16-3	S37037001	1	ナベコヒラザ5X32	SCREW, PAN (P WASHER) M5X32	



Z. 付属品関係 / Accessories / Zubehör / Accessoires / Accesorios

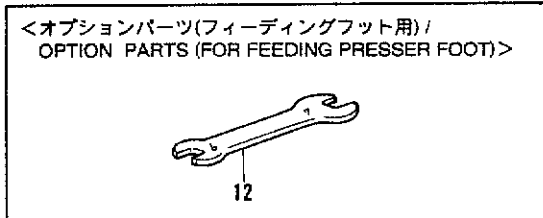
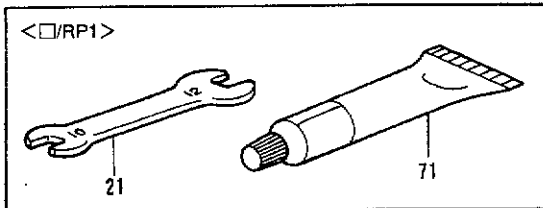
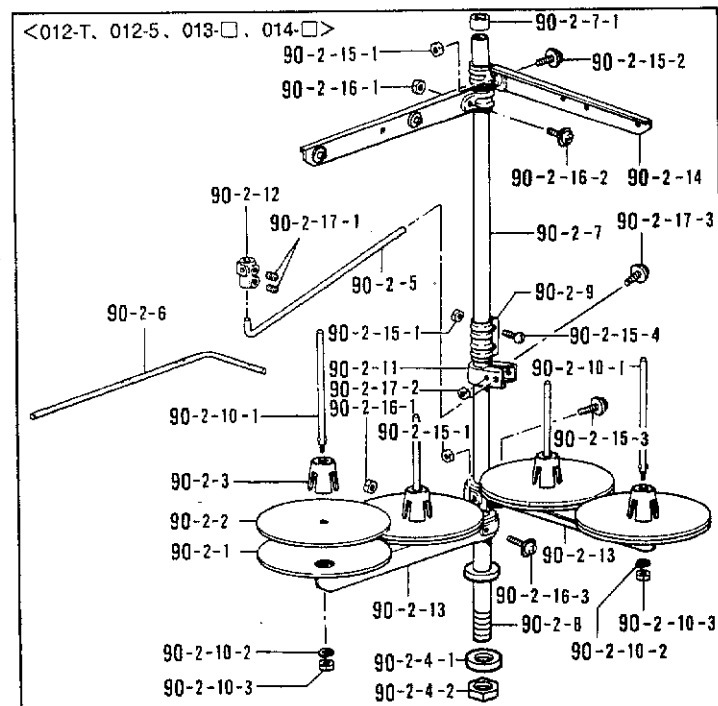
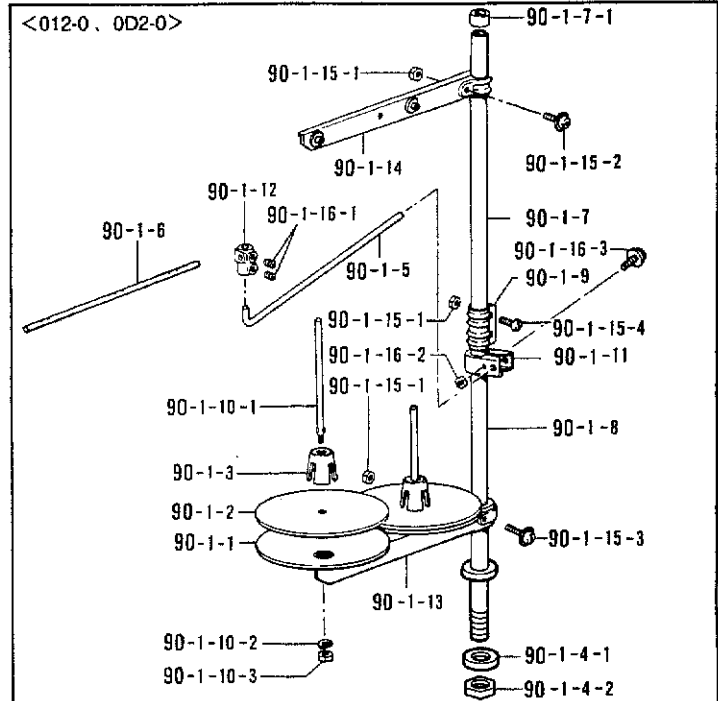
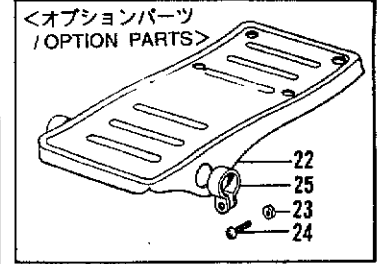
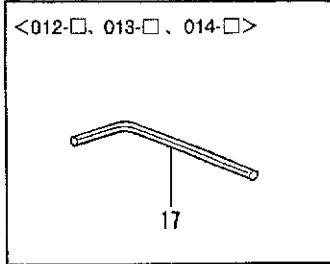
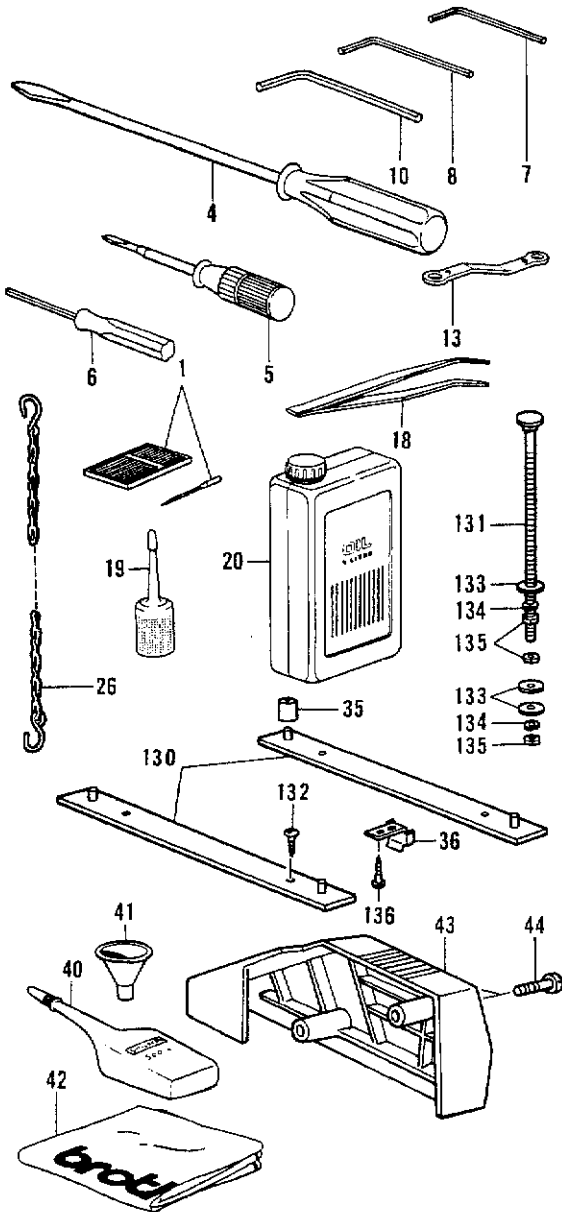

- ◎ 付属品の明細は変更することがあります。
- ◎ The details of included accessories are subject to change.
- ◎ Änderungen in der Aufstellung der Mitgelieferten Zubehöre sind vorbehalten.
- ◎ Les détails des accessoires inclus sont sujets à des changements.
- ◎ Los detalles de los accesorios incluidos pueden variar.







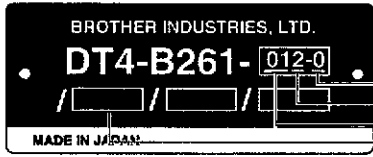



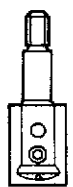

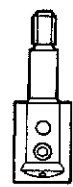

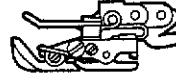

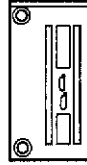
Z. 付属品関係 / Accessories / Zubehör / Accessoires / Accesorios

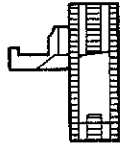
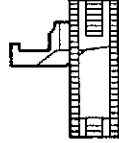
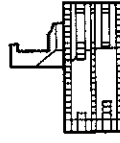

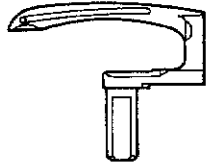



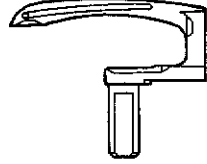
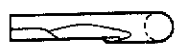
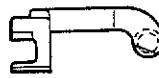
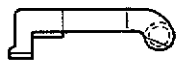

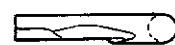

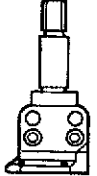
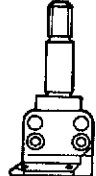

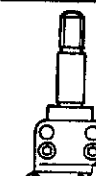



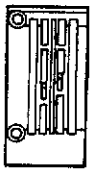
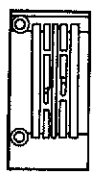

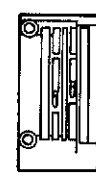
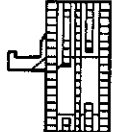
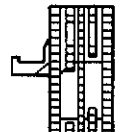
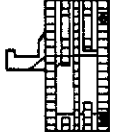
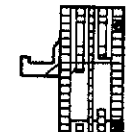

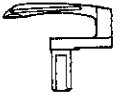
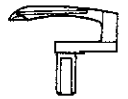
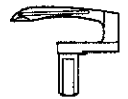
REF.NO.	CODE	Q'TY	ヒンメイ	NAME OF PARTS	RM
			<012-T,012-5,013-□,014-□, □/RP1>	<012-T,012-5,013-□,014-□,□/RP1>	
90-2	S29854109	1	イトタテダイクミ4DTHF	COTTON STAND ASSY, 4DTHF	
90-2-1	150180001	4	ウケザラ	SPOOL STAND BASE	
90-2-2	150182000	4	スプールマット	SPOOL MAT	
90-2-3	126863001	4	スプールクッション	SPOOL CUSHION	
90-2-4	S02775001	1	パイプネジセットA	PIPE SCREW SET, A	
90-2-4-1	150206002	1	ヒラザガネ16	WASHER, PLAIN 16	
90-2-4-2	S38648001	1	6カクナツトU5/8	NUT, U5/8-28	
90-2-5	S04109001	1	イトアンナイササエボウ	THREAD GUIDE SUPPORT BAR	
90-2-6	142998101	1	イトアンナイ4	THREAD GUIDE, 4	
90-2-7	S40640001	1	コラムパイプキャップツキ	COLUMN PIPE WITH CAP	
90-2-7-1	150174000	1	コラムキャップ	COLUMN CAP	
90-2-8	156112003	1	コラムパイプD	COLUMN PIPE, D	
90-2-9	150173003	1	コラムジョイント	COLUMN JOINT	
90-2-10	S21798001	4	スプールネジセット	SPOOL SCREW SET	
90-2-10-1	150179002	4	スプールジクB	SPOOL SHAFT, B	
90-2-10-2	028050246	4	バネザガネ2-5	WASHER, SPRING 2-5	
90-2-10-3	021500106	4	1シユナツト5	NUT, 1 M5	
90-2-11	150185009	1	イトアンナイホルダー	THREAD GUIDE HOLDER	
90-2-12	138843001	1	ササエボウツギテ	JOINT	
90-2-13	S02778002	2	スプールホルダー2	SPOOL HOLDER, 2	
90-2-14	S02786002	2	スレッドハンガークミ2	THREAD HANGER ASSY, 2	
90-2-15	S40641001	1	スプールジクネジセットA	SPOOL SCREW SET, A	
90-2-15-1	021500106	4	1シユナツト5	NUT, 1 M5	
90-2-15-2	S37038001	1	ナベコヒラザ5X14	SCREW, PAN (P WASHER) M5X14	
90-2-15-3	S37037001	1	ナベコヒラザ5X32	SCREW, PAN (P WASHER) M5X32	
90-2-15-4	062501406	2	ナベコ5X14	SCREW, PAN M5X14	
90-2-16	S40642001	1	スプールジクネジセットB	SPOOL SHAFT SCREW SET, B	
90-2-16-1	021500106	2	1シユナツト5	NUT, 1 M5	
90-2-16-2	S37038001	1	ナベコヒラザ5X14	SCREW, PAN (P WASHER) M5X14	
90-2-16-3	S37037001	1	ナベコヒラザ5X32	SCREW, PAN (P WASHER) M5X32	
90-2-17	S40643001	1	ホルダーツギテネジセット	HOLDER JOINT SCREW SET	
90-2-17-1	014060632	2	アナトメ6X6クボミ	SET SCREW, SOCKET (CP) M6X6	
90-2-17-2	021500106	1	1シユナツト5	NUT, 1 M5	
90-2-17-3	S37037001	1	ナベコヒラザ5X32	SCREW, PAN (P WASHER) M5X32	
1	S08715116	1	<0D2-0,012-□> ミシンハリ100クミ	<0D2-0,012-□> NEEDLE ASSY, #100	
1	S08715121	1	<013-□,013-□/RP1> ミシンハリ130クミ	<013-□,013-□/RP1> NEEDLE ASSY, #130	
1	S08715122	1	<014-□,014-□/RP1> ミシンハリ140クミ	<014-□,014-□/RP1> NEEDLE ASSY, #140	
17	118064001	1	<012-□,013-□,014-□, □/RP1> 6カクボウスバナ4	<012-5,013-□,014-□,□/RP1> HEXAGONAL WRENCH, 4	
21	107780001	1	<□/RP1> スパナ10X12	<□/RP1> WRENCH, 10X12	
71	S09021100	1	グリス	GREASE	
12	107779001	1	<オプションパーツ (フィーディングフットヨウ)> スパナ6X7	<OPTION PARTS (FOR FEEDING FOOT)> WRENCH, 6X7	
22	147893009	1	<オプションパーツ> オサエアゲフミイタ	<OPTION PARTS> TREADLE PEDAL	
23	021400106	2	ナツト1シユ4	NUT, 1 M4	
24	062401406	2	ナベコ4X14	SCREW, PAN M4X14	
25	116016001	2	ペタルトメ	PEDAL STOPPER	

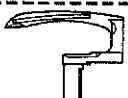

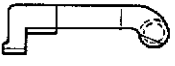
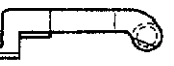
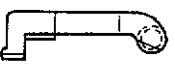



ゲージ部品一覧表/GAUGE PARTS LIST/LEHRENLISTE/  
LISTEDES PIÈCES P'ECARTEMENT/LISTA DE PIEZAS CALIBRADORAS

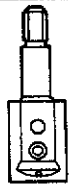

針数  
仕様  
送り方式  
装置  
No. of needles  
Specifications  
Feed method  
Devices

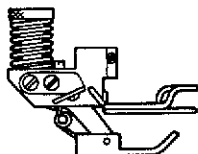
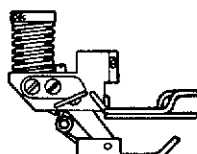
仕 様 Specifications	012-0	012-T	012-5	0D2-0
仕 様 ラ ベ ル Label	S28933-003	S28933-004	S28933-005	S28933-006
用 途 Application	地縫用 Plain Stitching	地縫用 Plain Stitching	タコ巻縫用 Binding Stitching	地縫用 Plain Stitching
針 数 (本) No. of Needles	1	2	2	1
針 巾 (mm) Needle Spacing (mm)	-	0.4	6.4	-
針 止 メ 組 Needle Clamp Assembly	 S17480-101	 S40962-001	 S40987-001	 S17480-101
押 工 組 Presser Foot Assembly	 S40541-101	 S40969-101	 S40990-101	 S40952-101
針 板 Needle Plate	 S40538-001	 S40964-001	 S40989-001	 S40538-001
送 り 歯 Feed Dog	 S40565-001	 S40972-001	 S40995-001	 S40954-001  S40955-001
ル ー パ Looper	 S40569-001	 S40973-001  S40974-001	 S40973-001  S40974-001	 S40569-001
ハ リ ウ ケ Needle Guard	 S08756-001	 S40967-001	 S40985-001  S40986-001	 S08756-001

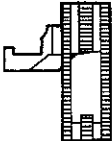
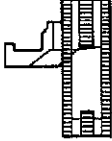
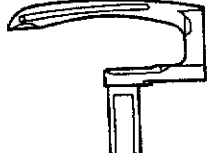
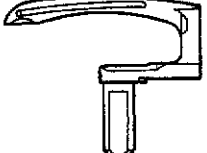
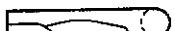
仕様 Specifications	013-5	013-6	014-5	014-6
仕様ラベル Label	S28933-008	S28933-009	S28933-010	S28933-011
用途 Application	厚物用 Heavy Materials	厚物用 Heavy Materials	厚物用 Heavy Materials	厚物用 Heavy Materials
針数(本) No. of Needles	2	2	2	2
針巾(mm) Needle Spacing (mm)	6.4	7.2	6.4	7.2
針止メ組 Needle Clamp Assembly	 S40987-101	 S44880-001	 S40987-101	 S44880-001
押し工組 Presser Foot Assembly	 S44888-001	 S44892-001	 S44891-001	 S44894-001
針板 Needle Plate	 S44883-001	 S44885-001	 S44884-001	 S44886-001
送り Feed Dog	 S44904-001	 S44904-001	 S44901-001	 S44901-001
ルーパー Looper	 S40973-001	 S40973-001	 S40973-001	 S40973-001
	 S40974-001	 S40974-001	 S40974-001	 S40974-001
ハリウケ Needle Guard	 S40985-001	 S40985-001	 S40985-001	 S40985-001
	 S40986-001	 S40986-001	 S40986-001	 S40986-001

仕様 Specifications	for 012-0	for 012-0
仕様ラベル Label	Option	Option
用途 Application	地縫用(薄物用フィーディングフット付) Plain Stitching (Thin W / Feeding Presser Foot)	地縫用(中厚用フィーディングフット付) Plain Stitching (Medium Thick W / Feeding Presser Foot)
針数(本) No. of Needles	1	1
針間(mm) Needle Spacing (mm)	-	-
針止メ組 Needle Clamp Assembly	 S17480-101	 S17480-101
押し組 Presser Foot Assembly	 S40548-001	 S40548-001
針板 Needle Plate	 S40538-001	 S40538-001
送り歯 Feed Dog	 S40564-001	 S40565-001
ルーパー Looper	 S40569-001	 S40569-001
ハリウケ Needle Guard	 S08756-001	 S08756-001

索引 / INDEX / VERZEICHNIS  
/ INDEX / INDICE

CODE	REF.NO.	Page
S00017001	A - 102	2
S00075000	A - 90-3	2
S00313009	A - 24	2
	A - 123	4
S00356001	L - 51	38
S00383001	L - 52	38
S00879001	E - 25	18
S01295001	E - 40-7-3	22
S01943001	Z - 6	44
S02556001	G - 33	28
S02606000	A - 5	2
S02775001	Z - 90-1-4	44
	Z - 90-2-4	46
S02778002	Z - 90-1-13	44
	Z - 90-2-13	46
S02786002	Z - 90-1-14	44
	Z - 90-2-14	46
S03704002	B - 50	10
	F - 46	24
	J - 28	34
S04109001	Z - 90-1-5	44
	Z - 90-2-5	46
S06701000	Z - 19	44
S06704001	Z - 40	44
S07317001	A - 90-6	2
S08467000	F - 70	24
S08627001	A - 2-1	6
	A - 2-1	6
	A - 2-1	6
	A - 2-1	8
	A - 2-1	8
S08628000	A - 3	2
S08631000	A - 16	2
S08633101	A - 26	2
S08634151	A - 30-1	6
	A - 30-1	8
S08637001	A - 33-1	6
	A - 33-1	6
	A - 33-1	6
	A - 33-1	8
	A - 33-1	8
S08639000	A - 35-1	6
	A - 35-1	6
	A - 35-1	6
	A - 35-1	8
S08640001	A - 36-1	6
	A - 36-1	6
	A - 36-1	6
	A - 36-1	8
S08642001	A - 38	2
S08646100	A - 40	2
S08647101	A - 41-1	6
	A - 41-1	6
	A - 41-1	6
	A - 41-1	8
S08651001	A - 42	2
S08652000	A - 43	2
S08653001	A - 48	2
S08665001	A - 100	2
S08667001	A - 105	2
S08668001	A - 108	4
S08670000	A - 116	4
S08671101	A - 119	4

CODE	REF.NO.	Page
S08672000	A - 120	4
S08673000	A - 124	8
	A - 128	4
S08674000	A - 138	4
S08675000	A - 139	4
S08682001	B - 3	10
S08683000	B - 4	10
S08684101	B - 6	10
S08685001	B - 6-1	10
S08686101	B - 6-2	10
S08687001	B - 8-1	12
	B - 8-1	12
	B - 8-1	12
	B - 8-1	12
	B - 8-1	12
S08688051	B - 9	10
S08689001	B - 11-1	12
	B - 11-1	12
	B - 11-1	12
S08692101	B - 16	10
S08693001	B - 16-1	10
S08694001	B - 16-2	10
S08695001	B - 16-4-1	10
S08696000	B - 23	10
S08697000	B - 24	10
S08698001	B - 25	10
S08715016	B - 31	12
	B - 31	12
	B - 31	12
S08715021	B - 31	12
	B - 31	14
S08715022	B - 31	12
	B - 31	14
S08715116	Z - 1	46
S08715121	Z - 1	46
S08715122	Z - 1	46
S08716301	B - 35-1	12
	B - 35-1	12
	B - 35-1	12
S08750001	B - 42	10
S08751001	B - 44	10
S08752001	B - 46	10
S08753000	B - 48	10
S08754000	B - 49	10
	J - 27	34
S08755101	B - 51	10
S08756001	B - 53-1	12
S08758109	C - 1	16
S08760009	C - 1-1	16
S08761100	C - 3	16
S08767001	E - 1	18
S08768001	E - 2	18
S08769001	E - 6	18
S08770000	E - 12	18
	J - 7	34
	L - 49	38
S08771001	E - 14	18
S08774001	E - 18-1	20
	E - 18-1	20
S08775000	E - 28	18
S08776001	E - 30	18
S08777001	E - 31	18
S08870001	F - 8	24

CODE	REF.NO.	Page
S08871001	F - 10	24
S08872001	F - 20-2	26
S08873001	F - 20-2-1	26
S08876000	F - 36	24
S08877001	F - 44	24
S08878001	F - 54	26
S08879001	F - 57	26
S08880001	F - 58	26
S08881101	F - 64	26
S08889101	H - 1	32
S08890001	H - 1-1	32
S08891001	H - 5	32
S08892001	H - 8	32
S08895002	H - 10	32
S08896101	H - 11	32
S08897001	H - 11-1	32
S08898000	H - 13	32
S08899001	H - 14	32
S08900000	H - 16	32
S08903000	H - 17	32
S08904000	H - 20	32
S08911000	J - 8	34
S08912001	J - 10-1	34
S08914001	J - 20	34
S08915001	J - 23	34
S08917000	J - 26	34
S08918001	J - 29	34
S08919001	J - 32	34
S08920001	J - 33	34
S08921101	J - 35	34
S08935001	K - 1	36
S08936201	K - 3	36
S08937101	K - 3-4	36
S08939100	K - 3-6	36
S08940000	K - 6	36
S08943000	K - 12	36
S08944001	K - 13	36
S08945001	K - 16	36
S08946000	K - 18	36
S08948001	K - 22	36
S08951001	K - 26	36
S08953001	K - 37	36
S08955051	K - 32	36
S08956100	K - 34	36
S08957001	K - 35	36
S08958001	K - 40	36
S08961101	L - 1	38
S08962109	L - 7	38
S08963001	L - 10-1	40
	L - 10-2	40
	L - 10-2	40
S08964001	L - 11-1	40
	L - 11-2	40
	L - 11-2	40
S08965009	L - 27	38
S08966001	L - 28	38
S08967001	H - 19	32
	L - 29	38
S08968001	L - 31	38
S08969201	L - 40	38
S08970001	L - 91-1	40
S08971201	L - 45	38
S08976001	L - 50	38

索引 / INDEX / VERZEICHNIS  
/ INDEX / INDICE

CODE	REF.NO.	Page
S08977001	L - 54	38
S08978001	L - 57	38
S08981001	L - 68	38
S08982001	L - 70-1	40
	L - 70-1	40
	L - 70-1	42
S08983001	L - 72	38
S08984001	L - 73-2	42
S08987001	L - 104	38
S08992001	L - 102	38
S08993101	L - 108	38
S08994001	L - 111	38
S09001101	Z - 36	44
S09002009	Z - 43	44
S09021100	Z - 71	46
S09039001	G - 36-2	28
S09120001	B - 16-3	10
S09121001	B - 41	10
S09123101	A - 34	2
S09124001	B - 38	10
S09125001	K - 45	36
S09251001	J - 35-1	34
S09316000	K - 42	36
S10774001	A - 14	2
S11561001	Z - 130	44
S11562001	Z - 131	44
S11588001	J - 25-1	34
S11589000	J - 37	34
S12703001	A - 2-2	8
S12724001	B - 8-2	14
	B - 8-2	14
S12725101	B - 11-2	12
	B - 11-2	12
	B - 11-2	14
	B - 11-2	14
S12821001	G - 1-4	28
S12858000	G - 46-1	30
S12882001	L - 91-2	40
	L - 91-2	42
	L - 93	40
	L - 93	42
	L - 113-2	40
	L - 113-2	42
	L - 125-2	40
	L - 125-2	42
	L - 128	38
S12900001	G - 36-5	28
S12913201	G - 1-1	28
S12915001	G - 1-2	28
S12916001	G - 1-3	28
S12918000	G - 14	28
S12919001	G - 16	28
S12920001	G - 18	28
S12921001	G - 19	28
S12922001	G - 20	28
S12923001	G - 22	28
S12924001	G - 26	28
S12933001	G - 32	28
S12934101	G - 36	28
S12936001	G - 37	28
S12937101	G - 39	28
S12939001	G - 43	28
S12942001	G - 49	30

CODE	REF.NO.	Page
S12943001	G - 51	30
S12946001	G - 59	30
S13085001	E - 40-3-6	20
S13385001	B - 39	10
S13414201	G - 1	28
S13415101	G - 36-1	28
S14621001	B - 1-2	10
S14622001	H - 1-2	32
S14623001	H - 11-2	32
S16249001	F - 80	24
S16498001	F - 1-1	24
S17773001	G - 2	28
S18530001	L - 94	38
S18532001	L - 96	38
S18534001	L - 98	38
S18535001	L - 100	38
S18947001	E - 21-2	20
	E - 21-2	20
S20118151	E - 40-1-2	20
	E - 40-2-2	20
	E - 40-3-12	20
	E - 40-7-15	22
S21798001	Z - 90-1-10	44
	Z - 90-2-10	46
S23359001	F - 22	26
	F - 27	24
S25818051	L - 129	38
S28007001	A - 68	8
S28008000	A - 69	8
S28250001	G - 6	28
S28252000	G - 6-2	28
S28253001	G - 11	28
S28254001	G - 28	28
S28256001	G - 29	28
S28261001	G - 46	30
S28263001	G - 52	30
S28264001	G - 53	30
S28265001	G - 66	30
S28266001	G - 68	30
S28333001	G - 61	30
S28334001	G - 41	28
S28438001	L - 73-1	38
S28802001	A - 90	2
S28803001	A - 90-1	2
S28804001	A - 90-2	2
S28809201	A - 20	2
S28810051	A - 15	2
S28957001	B - 1	10
S28958001	B - 1-1	10
S29854109	Z - 90-2	46
S30086001	B - 16-4	10
S30564000	L - 17-1	40
	L - 17-2	40
	L - 17-2	42
S30565002	L - 22	40
	L - 22	42
	L - 24	40
	L - 24	42
S30565003	L - 21	40
	L - 21	40
	L - 21	42
	L - 23	40
	L - 23	40

CODE	REF.NO.	Page
S30565003	L - 23	42
S31012001	E - 19	18
S31013001	E - 20	18
S34200000	A - 81	6
	A - 81	6
	A - 81	6
	A - 81	8
S36894000	E - 40-3-14	20
S37037001	Z - 90-1-15-3	44
	Z - 90-1-16-3	44
	Z - 90-2-15-3	46
	Z - 90-2-16-3	46
	Z - 90-2-17-3	46
S37038001	Z - 90-1-15-2	44
	Z - 90-2-15-2	46
	Z - 90-2-16-2	46
S38648001	Z - 90-1-4-2	44
	Z - 90-2-4-2	46
S39086001	F - 34	24
S40358101	E - 40-2-5	20
S40360001	E - 40-2-7	20
S40374001	E - 40-2-9	20
S40532001	A - 12	2
S40533001	A - 115	4
S40535001	A - 65	6
	A - 65	6
	A - 65	8
S40539001	E - 35	20
S40544101	E - 40-3-2	20
S40546001	E - 40-1-4	20
S40549101	E - 40-3-1	20
S40555001	E - 40-3-3	20
S40556001	E - 40-3-4	20
S40557001	E - 40-3-10	20
S40558001	E - 40-3-9	20
S40559001	F - 47	26
S40562001	F - 20-1	26
S40567001	J - 1	34
S40569001	J - 14-1	34
S40570001	L - 120	38
S40571001	L - 122-1	40
	L - 122-1	42
	L - 122-2	40
S40572001	L - 116	38
S40574009	Z - 90-1	44
S40640001	Z - 90-1-7	44
	Z - 90-2-7	46
S40641001	Z - 90-1-15	44
	Z - 90-2-15	46
S40642001	Z - 90-2-16	46
S40643001	Z - 90-1-16	44
	Z - 90-2-17	46
S40960051	A - 30-2	6
	A - 30-2	6
	A - 30-2	8
	A - 30-2	8
S40961001	A - 32	6
	A - 32	6
	A - 32	8
	A - 32	8
S40965001	B - 55	12
	B - 55	12
	B - 55	12

索引 / INDEX / VERZEICHNIS  
/ INDEX / INDICE

CODE	REF.NO.	Page
S40965001	B - 55	14
	B - 55	14
S40966001	B - 58	12
	B - 58	12
	B - 58	12
	B - 58	14
	B - 58	14
S40967001	B - 53-2	12
S40973001	J - 14-2	34
	J - 14-2	34
S40974001	J - 14-3	34
	J - 14-3	34
S40975001	J - 10-3	34
	J - 10-3	34
S40976001	J - 10-2	34
	J - 10-2	34
S40977001	J - 5	34
S40985101	B - 53-3	12
	B - 53-3	12
	B - 53-3	12
	B - 53-3	14
	B - 53-3	14
S40986101	B - 60-3	12
	B - 60-3	12
	B - 60-3	12
	B - 60-3	14
	B - 60-3	14
S40996001	J - 16	34
S44875001	A - 33-4	8
S44876001	A - 36-4	8
	A - 36-4	8
S44877001	A - 71	8
S44878001	A - 41-4	8
	A - 41-4	8
S44879001	A - 73	8
	A - 73	8
S44882001	B - 35-3	12
	B - 35-3	12
	B - 35-3	14
	B - 35-3	14
S44887001	E - 18-2	22
S44902001	F - 75-1-1	26
S44903001	F - 75-1-2	26
S44906001	G - 44	30
S44907001	G - 100	30
S44911001	L - 70-2	40
S44912000	D - 10-2	16
014060632	Z - 90-1-16-1	44
	Z - 90-2-17-1	46
014680422	B - 54	10
	B - 57	12
	B - 57	12
	B - 57	12
	B - 57	14
	B - 57	14
	B - 59	12
	B - 59	12
	B - 59	12
	B - 59	14
	B - 59	14
	E - 40-3-11	20
	G - 13	28
	G - 67	30

CODE	REF.NO.	Page
014680422	J - 15-1	34
	J - 15-2	34
	J - 15-2	34
	L - 5	40
	L - 5	40
	L - 6	38
	L - 71	38
	L - 117	38
014680622	B - 43	10
	B - 45	10
	J - 21	34
	K - 17	36
014760622	B - 15	10
	B - 18-1	12
	B - 18-1	12
	B - 18-1	12
	E - 26	18
	G - 1-1-4	28
	G - 50	30
014770622	B - 2	10
	B - 5	10
	B - 7	10
	B - 13	10
	B - 50-1	10
	F - 46-1	24
	F - 47-1	26
	G - 3	28
	G - 54	30
	H - 9	32
	H - 12	32
	H - 15	32
	J - 24	34
	J - 28-1	34
	K - 2	36
	L - 45-1	38
014780622	F - 43	24
	H - 2	32
017681012	G - 69	30
017781412	F - 67	26
	K - 4	36
018060822	A - 13	2
018061622	G - 17	28
	G - 47	30
018063022	G - 7	28
018081622	A - 140	4
018401422	L - 45-2	38
018501022	F - 71-1	26
018680822	L - 41	38
	L - 97	38
018681022	B - 36	10
	B - 37-2	14
	B - 37-2	14
	B - 52	10
018771432	E - 10	18
	F - 7	24
	F - 48	26
	F - 50	26
	F - 54-2	26
	F - 57-1	26
	G - 2-1	28
	H - 7	32
	J - 2	34
	J - 12-1	34

CODE	REF.NO.	Page
018771432	J - 12-2	34
	J - 12-2	34
	L - 47	38
	L - 55	38
021080106	Z - 135	44
021400106	Z - 23	46
021500106	Z - 90-1-10-3	44
	Z - 90-1-15-1	44
	Z - 90-1-16-2	44
	Z - 90-2-10-3	46
	Z - 90-2-15-1	46
	Z - 90-2-16-1	46
	Z - 90-2-17-2	46
021630102	E - 40-1-5	20
021670102	G - 106	30
021670202	E - 40-3-7	20
025030232	A - 90-5	2
025050232	A - 90-8	2
025080132	A - 35-2	8
	A - 35-2	8
025080336	Z - 133	44
025350332	K - 3-2	36
025680133	A - 83	2
025770232	F - 66	26
028050246	A - 90-7	2
	Z - 90-1-10-2	44
	Z - 90-2-10-2	46
028080242	Z - 134	44
032461606	Z - 136	44
047200642	C - 1-2	16
047400842	G - 65	30
047502242	F - 63	26
048040342	F - 9	24
048090142	G - 30	28
048150143	F - 1-12	24
060660416	L - 112	38
060670512	A - 90-10	2
060670812	L - 121	38
060680512	F - 81	24
060680712	A - 91	2
	A - 106	2
	E - 3	18
	L - 95	38
060681612	A - 45	2
062350612	L - 130	38
062401406	Z - 24	46
062501406	Z - 90-1-15-4	44
	Z - 90-2-15-4	46
062630612	E - 40-1-3	20
	G - 1-5	28
	J - 34	34
062660412	J - 4	34
062660512	A - 90-4	2
	E - 40-7-10	22
	F - 1-8	24
062660712	F - 54-1	26
062670412	E - 40-2-3	20
	E - 40-3-13	20
	E - 40-7-16	22
062670512	L - 99	38
	L - 109	38
	L - 126	38
062670612	A - 136	4



索引 / INDEX / VERZEICHNIS  
/ INDEX / INDICE

CODE	REF.NO.	Page
062670612	B -21	10
	K -8	36
	K -10	36
	K -14	36
	K -23	36
	K -41	36
	K -51	36
	L -69	38
	L -123-1	40
	L -123-1	42
	L -123-2	40
062670812	F -19	24
	H -25	32
	K -3-3	36
062671012	B -56	12
	B -56	12
	B -56	12
	B -56	14
	B -56	14
	K -3-8	36
062671212	E -40-1-1	20
062680612	A -47	2
	G -45	30
	H -4	32
	L -92	38
062680812	A -27	6
	A -27	8
	A -70	8
	A -101	2
	B -37-1	12
	B -37-1	12
	B -37-1	12
	B -37-1	12
	B -37-1	12
	B -37-1	12
	K -33	36
	K -43	36
	L -2	38
	L -74	38
062681012	A -4	2
	A -21	2
	A -28	6
	A -28	6
	A -28	8
	A -28	8
	A -111	4
	F -31	24
	F -35	24
	L -8	38
	L -58	38
062681212	L -32	38
062681412	A -51	2
	E -29	18
062681612	A -17	2
062682012	G -55	30
062710812	A -66	6
	A -66	6
	A -66	6
	A -66	8
	A -66	8
	A -66	8
062711012	B -10	10
062780812	K -46	36
072600000	H -22	32

CODE	REF.NO.	Page
081003670	F -12	24
081014670	A -6	2
081032870	H -18	32
081044070	K -36	36
081046870	B -26	12
	B -26	12
	B -26	14
	B -26	14
087311215	C -2	16
100025002	F -1-17	24
100032004	A -31	2
100064005	B -16-4-2	10
	E -40-2-1	20
	E -40-7-14	22
100251001	F -5	24
100257010	G -105	30
100294002	F -61	26
100526003	G -26-1	28
100645003	A -80	2
	E -38	20
	F -30	24
	K -44	36
	L -39	38
	L -59	38
100666002	Z -132	44
101572101	Z -4	44
101706001	A -104-1	2
	F -40	24
102424004	Z -44	44
102538002	G -101	30
102571003	E -37	20
102630001	B -22	10
104449009	A -22	2
104450109	A -60	8
	A -130	4
104464001	B -12	10
105161004	E -40-3-8	20
	G -1-1-3	28
	L -110	38
	L -115	38
	L -124-1	40
	L -124-1	42
	L -124-2	40
	L -127	38
105234003	A -52	2
	A -112	4
	G -56	30
105343001	Z -13	44
105812003	G -35	28
106128004	G -38	28
	G -42	28
106129001	A -90-9	2
106588003	G -64	30
107153001	B -17	10
	G -34	28
107272002	F -45	24
	G -31	28
107407003	A -109	4
	A -117-1	6
	A -117-1	6
	A -117-1	6
	A -117-1	8
	A -117-1	8

CODE	REF.NO.	Page
107407003	A -117-2	8
	A -121-1	6
	A -121-1	6
	A -121-1	6
	A -121-1	8
	A -121-1	8
	A -121-2	8
107453001	G -24	28
107779001	Z -12	46
107780001	Z -21	46
108520009	A -23	6
	A -23	6
	A -23	6
	A -23	8
	A -23	8
108960002	A -72	8
	A -74	8
	A -74	8
109203001	A -142	4
	F -62	26
109239001	G -60	30
110140001	G -25	28
	G -27	28
110161006	J -31	34
110167001	G -57	30
110168001	G -58	30
110641002	A -141	4
110704001	J -3	34
110793001	E -7	18
110813001	L -12-1	40
	L -12-2	40
	L -12-2	40
110832009	L -14-1	40
	L -14-2	40
	L -14-2	40
111105002	E -40-2-6	20
	E -40-3-5	20
	E -40-7-12	22
112299001	L -76	42
112300001	L -75	42
112301001	L -77	42
112351001	K -27	36
112359052	K -30	36
	K -38	36
112364001	K -24	36
112467002	K -3-11	36
112700001	G -63	30
112743001	K -7	36
112754001	K -53	36
113431002	F -52	26
113644001	G -1-1-1	28
113880001	D -10-1	16
114294001	H -21	32
114985001	A -46	2
116016001	Z -25	46
117466000	Z -18	44
117516001	A -122-1	6
	A -122-1	6
	A -122-1	6
	A -122-1	8
	A -122-1	8
	A -122-2	8
	A -126	8

索引 / INDEX / VERZEICHNIS  
/ INDEX / INDICE

CODE	REF.NO.	Page
117516001	E - 39	20
117517003	F - 1-16	24
117608001	G - 8	28
	G - 48	30
117934009	A - 19	2
118064001	Z - 17	46
118718001	L - 30	38
118770001	K - 11	36
118837001	Z - 5	44
118853001	B - 14	10
	G - 36-1-1	28
120990001	J - 35-1-1	34
121007001	G - 40	28
123185001	A - 37	2
	A - 39	2
126863001	Z - 90-1-3	44
	Z - 90-2-3	46
138843001	Z - 90-1-12	44
	Z - 90-2-12	46
140063001	A - 107	4
140092001	G - 12	28
140165001	F - 1-3	24
140176001	F - 1-15	24
140205001	F - 49	26
140207001	F - 21	26
140209001	F - 23	26
140210001	F - 24	26
140217001	F - 28	24
140313001	J - 35-2	34
140326009	F - 4	24
140327001	F - 14	24
	J - 9	34
140407001	E - 22	18
	E - 34	20
	E - 34	20
140759000	Z - 41	44
141183000	A - 103	2
141208001	E - 23	18
141728001	E - 21-1	20
	E - 21-1	22
142274009	A - 49	2
142359001	K - 5	36
142721001	Z - 8	44
142997001	Z - 90-1-6	44
142998101	Z - 90-2-6	46
143311001	H - 23	32
143312000	H - 24	32
143325001	E - 5	18
143564001	F - 51	26
143565001	F - 53	26
143602001	L - 42	38
144053001	F - 1-9	24
144055001	F - 1-10	24
144075001	G - 1-1-2	28
	L - 114	38
144103009	L - 15-1	40
	L - 15-2	40
	L - 15-2	42
144104001	L - 18-1	40
	L - 18-2	40
	L - 18-2	42
144110001	L - 19-1	40
	L - 19-2	40



CODE	REF.NO.	Page
144110001	L - 19-2	42
144224001	Z - 42	44
144504001	L - 105	38
144505000	L - 106	38
144619000	K - 3-1	36
144622001	K - 3-5	36
144875001	K - 3-9	36
144876001	K - 3-10	36
145277205	Z - 20	44
145446001	L - 16-1	40
	L - 16-2	40
	L - 16-2	42
145472001	E - 24	18
145663001	F - 1-2	24
145688000	B - 20	10
145737001	K - 21	36
146049001	Z - 7	44
146315009	A - 125	4
146354001	A - 67	6
	A - 67	6
	A - 67	6
	A - 67	8
	A - 67	8
	A - 67	8
146401001	F - 1-4	24
146402001	F - 1-5	24
146403001	F - 1-6	24
146404001	F - 1-7	24
146457001	A - 135	4
146528102	F - 1	24
146529001	F - 1-11	24
146530001	F - 1-13	24
146531001	F - 1-14	24
146532001	F - 2	24
146533001	F - 6	24
146538101	F - 13	24
146539000	F - 15	24
146540000	F - 16	24
146544000	F - 20-1-1	26
	F - 20-2-2	26
146547000	F - 41	24
146548101	F - 42	24
146554001	F - 25	24
146555001	F - 26	24
146556001	F - 55	26
146559001	F - 59	26
146560101	F - 60	26
146563001	F - 65	26
146586009	A - 50	2
	A - 110	4
	A - 129	4
146624101	J - 22	34
146741000	F - 39	24
146924000	L - 96-1	38
147318000	F - 3	24
147363000	K - 48	36
147527000	K - 3-7	36
147528100	K - 3-12	36
147529000	K - 3-13	36
147871001	E - 40-2-4	20
	E - 40-7-1	22
147872001	E - 40-7-2	22
147875001	E - 40-7-6	22

CODE	REF.NO.	Page
147876001	E - 40-7-7	22
147877001	E - 40-7-8	22
147878001	E - 40-7-9	22
147879001	E - 40-7-11	22
147880001	F - 75-1-3	26
147890001	E - 40-7-4	22
147893009	Z - 22	46
147919051	Z - 35	44
147932001	E - 40-2-8	20
	E - 40-7-5	22
148084001	A - 29	2
148120000	G - 6-1	28
148294001	G - 21	28
148372001	E - 4	18
148425001	J - 1-1	34
	J - 22-1	34
148834001	F - 56	26
148847001	J - 30	34
148851001	L - 18-3	40
149247001	Z - 26	44
150173003	Z - 90-1-9	44
	Z - 90-2-9	46
150174000	Z - 90-1-7-1	44
	Z - 90-2-7-1	46
150179002	Z - 90-1-10-1	44
	Z - 90-2-10-1	46
150180001	Z - 90-1-1	44
	Z - 90-2-1	46
150182000	Z - 90-1-2	44
	Z - 90-2-2	46
150185009	Z - 90-1-11	44
	Z - 90-2-11	46
150206002	Z - 90-1-4-1	44
	Z - 90-2-4-1	46
150335001	Z - 10	44
150604101	G - 36-3	28
150605001	G - 36-4	28
150644009	L - 3	40
	L - 3	40
150645009	L - 4	38
151059001	A - 137	4
151267001	A - 118	4
151429001	K - 9	36
151572101	E - 40-7-13	22
151584001	D - 10-3	16
151927001	K - 52	36
152718001	B - 18-2	12
	B - 18-2	12
	B - 18-2	14
	B - 18-2	14
153484001	F - 11	24
153675001	A - 44	2
153734001	H - 3	32
154574001	E - 36	20
154596000	E - 27	18
154841009	A - 61	8
	A - 63	8
154886001	H - 6	32
154956001	E - 9	18
154957001	E - 11	18
154965001	F - 71-2	26
	L - 101	38
	L - 103	38

索引 / INDEX / VERZEICHNIS  
/ INDEX / INDICE

CODE	REF.NO.	Page
155144001	F - 17	24
155145000	F - 18	24
155151000	F - 29	24
155162001	J - 13	34
	J - 13	34
	L - 56	38
155175051	F - 68	26
155176001	F - 69	26
155177100	F - 32	24
155178001	F - 33	24
155220000	E - 8	18
	L - 48	38
155282101	K - 29	36
155294100	K - 49	36
155295001	K - 50	36
155313001	L - 113-1	40
	L - 125-1	40
155510001	L - 107	38
155539000	B - 47	10
	E - 13	18
	J - 6	34
	L - 53	38
156112003	Z - 90-1-8	44
	Z - 90-2-8	46
156265001	G - 23	28
156887001	A - 64	8
157840000	K - 15	36
158437009	A - 25	6
	A - 25	6
	A - 25	6
	A - 25	8
	A - 25	8
159093009	G - 62	30
159150009	A - 7	2
	A - 62	8
	G - 15	28
159476000	K - 25	36
	K - 28	36
	K - 31	36
	K - 39	36
159574101	L - 13-1	40
	L - 13-2	40
	L - 13-2	40
183893001	A - 104	2

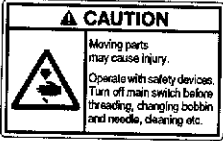
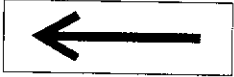
Wa. 警告ラベル / Warning labels / Warnschilder / Etiquettes d'avertissement /  
Etiquetas de advertencia

警告ラベル / Warning labels	品名 / Name of Parts	Size(mm)	Code
	操作注意ラベル・和	40X64	S38350-001
	Label, operation Eng.	40X64	S38349-001
	矢印マーク Mark, arrow	10X30	S37058-001
	アースマーク Mark, grounding	φ 12	S37060-001

**brother.**

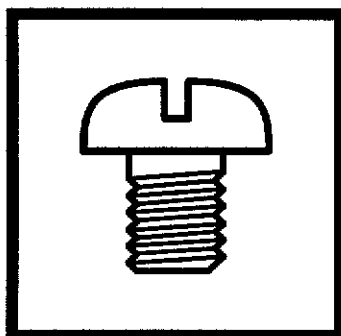

パーツブック  
PARTS BOOK  
TEILEKATALOG  
LIVRE DES PIECES  
LIBRO DE REFERENCIA DE PIEZAS

**ブラザー工業株式会社**

BROTHER INDUSTRIES, LTD.

〒467-8562 名古屋市瑞穂区河岸1丁目1番1号

Printed in Japan / Gedruckt in Japan / Imprimé au Japon / Impreso en Japón

118-261  
S95261-101  
1997.12 H ①