

Yamato[®]

INDUSTRIAL SEWING MACHINE

SPARE PARTS LIST

MODELS

DCZ-438K DCZ-440K



YAMATO CORPORATION

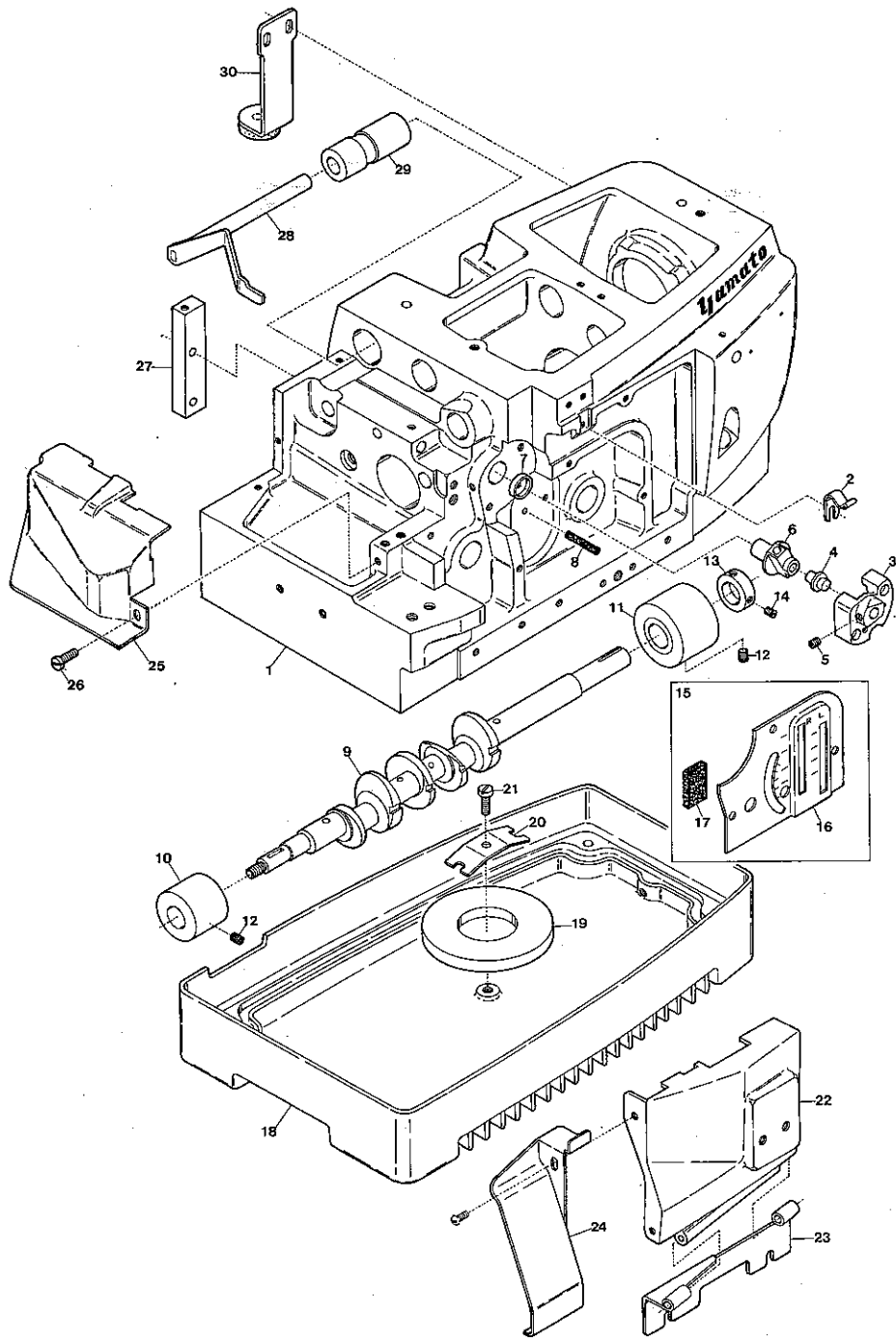

DCZ-438, 440 EXCLUSIVE PARTS (1)

サブクラス専用部品

Ref. No.	Parts No.	Description	品名	Ami. Req.
1	35144	Machine Frame	ベッド	1
2	35839	Front Cover Latch Spring	前開キカバーバネ	1
3	34342	Upper Looper Bar Guide Retainer	ルーバー案内蓋	1
4	34109	Upper Looper Bar Guide Thrust Pin	ルーバー案内決メピン	1
5	3638	Screw for 34109	ルーバー案内決メピン止ネジ	1
6	34341	Upper Looper Bar Guide	ルーバー案内	1
7	34337	Upper Looper Bar Guide Bushing Cap	ルーバー案内フッシュ蓋	1
8	282	Oil Wick for Upper Looper Bar Oiling Felt	油芯	1
9	35147	Crankshaft	クランクシャフト	1
10	35146	Crankshaft Bushing (Left)	小ブッシュ	1
11	35145	Crankshaft Bushing (Inner)	中ブッシュ	1
12	3635	Screw for 35146, 35145	ブッシュ止ネジ	2
13	32820	Crankshaft Thrust Collar	スラストカラー	1
14	7650	Screw for 32820	スラストカラー止ネジ	2
15	35838	Looper Thread Eyelet Supporter, Complete Set	前カバー(組)	1
16	34346	Looper Thread Eyelet Supporter	前カバー	1
17	308	Felt for 34346	フェルト	1
18	35851	Base	ベース	1
19	35149	Base Magnet	油受けマグネット	1
20	35150	Magnet Clamp	油受けマグネット押工	1
21	4440	Screw for 35150	油受けマグネット押工止ネジ	1
22	35158	Front Cover	前開キカバー	1
23	35157	Front Cover Hinge	前開キカバーヒンジ	1
24	35854	Chip Guard (Openable)	切屑落シ板(小)	1
25	35152	Feed Mechanism Cover	送りリンクカバー	1
26	4353	Screw for 35152	送りリンクカバー止ネジ	2
27	35156	Suction Pipe Supporter	吸込管取付台	1
28	35789	Foot Lifter Lever Shaft	押し揚ゲ軸レバ	1
29	35790	Foot Lifter Lever Shaft Bushing	押し揚ゲ軸ブッシュ	1
30	35884	Machine Frame Stay	ベッド支工具	1

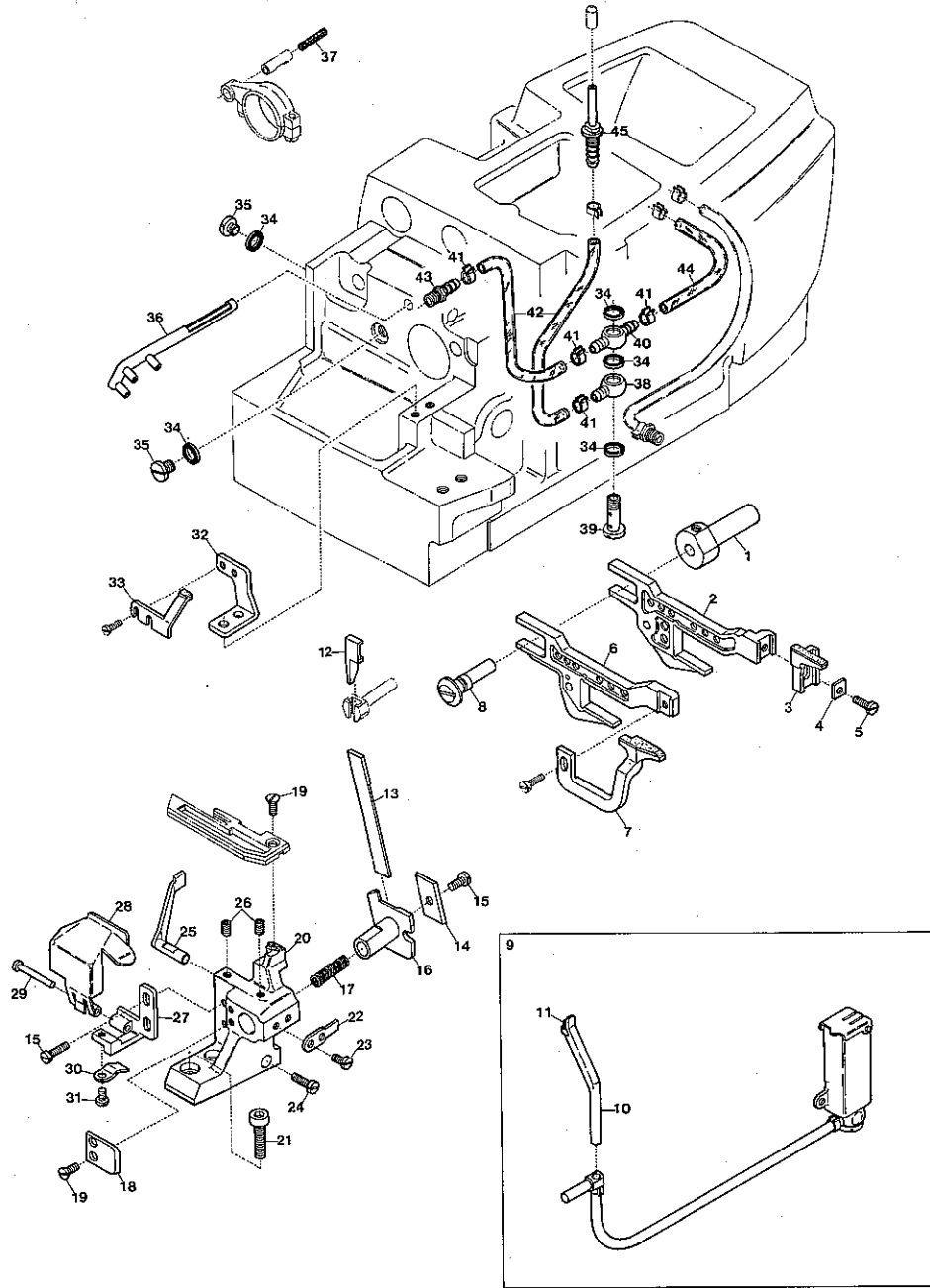

Ref. No.	Parts No.	Description	品名	Ami. Req.
1	35786	Feed Bar Guide (Rear)	送り台ガイド(後)	1
2	35785	Main Feed Bar	後送り台	1
3	35899	Main Feed Dog	後送り	1
4	35834	Lower Knife Guide	下刃ガイド	1
5	4320	Screw for 35834	下刃ガイド止ネジ	1
6	35784	Differential Feed Bar	前送り台	1
7	35898	Differential Feed Dog	前送り	1
8	35793	Feed Adjusting Pin	エキセンピン	1
9	35161	HR Device, Complete Set	HR装置	1
10	35162	Needle Guard (Front)	針受け(前)	1
11	276	Felt for HR Device	HR用フェルト	1
12	35892	Upper Knife Clamp	上メス押し	1
13	35897	Lower Knife	下メス	1
14	35860	Lower Knife Clamp	下メス押し	1
15	4353	Screw for 35860, 35880	止ネジ	3
16	35859	Lower Knife Holder	下メス台	1
17	35862	Lower Knife Spring	下メスバネ	1
18	35868	Lower Knife Spring Holder	下メスバネ押し	1
19	9142	Screw for 35868, Throat Plate	止ネジ	3
20	35855	Throat Plate Holder	針板受け	1
21	5520	Screw for 35855	針板受け止ネジ	2
22	35861	Lower Knife Holder Locking Plate	下メス台回り止め	1
23	7006	Screw for 35861	下メス台回り止め止ネジ	2
24	4437	Screw for 35161	HR装置止ネジ	1
25	35166	Needle Guard (Rear)	針受け(後)	1
26	3638	Screw for 35166, 35859	止ネジ	2
27	35880	Lower Looper Cover Hinge	下ルーバーカバーヒンジ	1
28	35782	Lower Looper Cover	下ルーバーカバー	1
29	35882	Lower Looper Cover Pin	下ルーバーカバーピン	1
30	35881	Lower Looper Cover Latch Spring	下ルーバーカバーバネ	1
31	1222	Screw for 35881	下ルーバーカバーバネ止ネジ	1
32	35792	Feed Bar Guide (Left)	送り台ガイド(左)	1
33	35779	Throat Plate Stay	針板支工	1
34	567	Seal for 1820, 37669, 37668	パッキン	5
35	1820	Screw for Machine Frame	ベッドネジ蓋	2
36	35864	Oil Nozzle for Feed Bar Driving Connection	給油管	1
37	309	Oil Wick for Upper Knife Driving Connecting Rod Pin	油芯	1
38	37669	Oil Tube Fitting One Way End	片口管継手	1
39	7667	Oil Tube Fitting Stud	管継手ボルト	1
40	37668	Oil Tube Fitting Two Way	両口管継手	1
41	37675	Oil Tube Clamp	緊束環	4
42	32850	Oil Tube (150mm)	オイルパイプ(150mm)	2
43	9909	Oil Tube Fitting Nut	パイプ継手	1
44	35148	Oil Tube (115mm)	オイルパイプ(115mm)	1
45	35151	Oil Sight Top Nozzle	ノズル	1

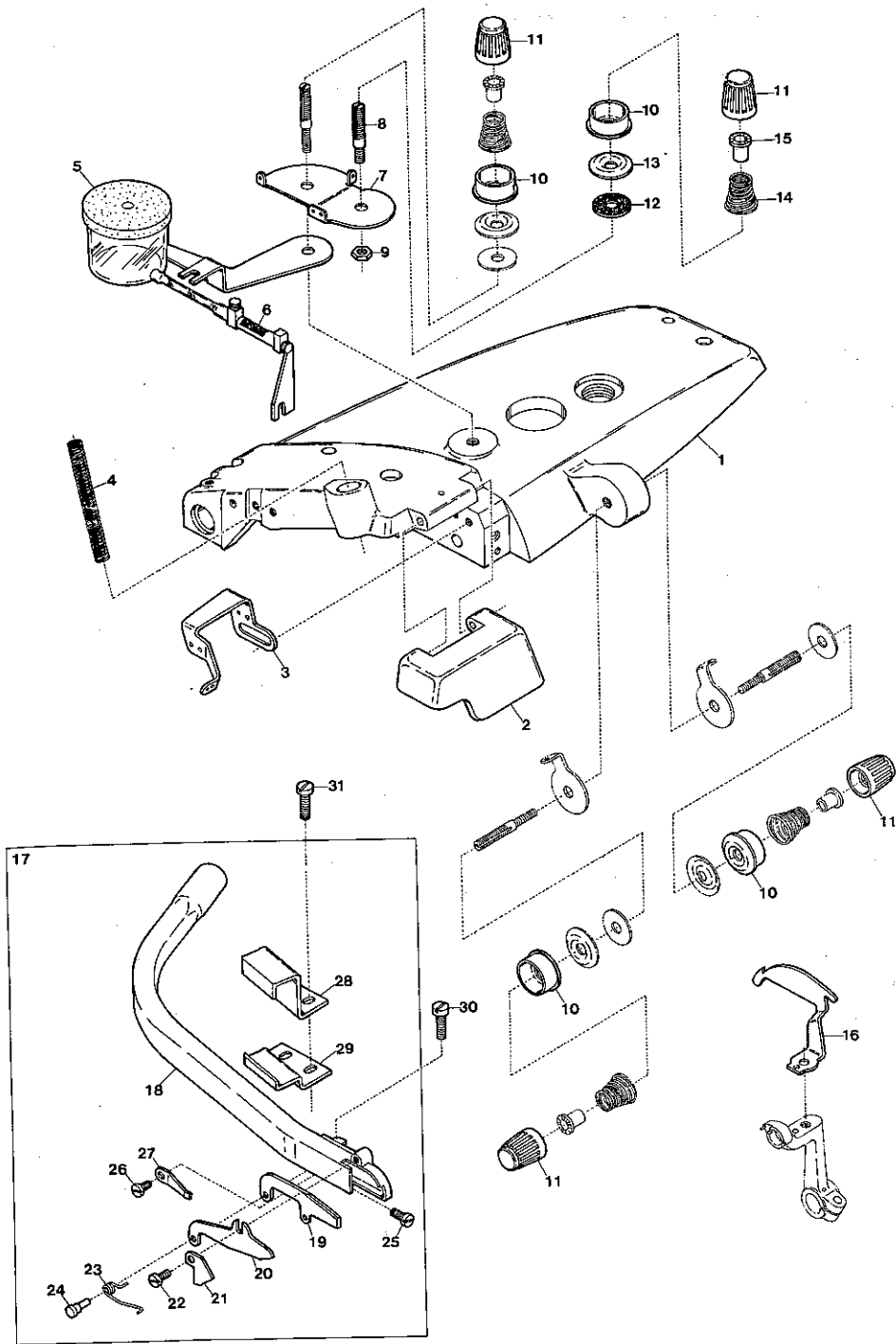

Ref. No.	Parts No.	Description	品名	Amt. Req.
1	35153	Top Cover	上カバー	1
2	35154	Top Front Cover	上メスカバー	1
3	34320	Needle Thread Eyelet	針糸道	1
4	35883	Presser Spring	押エバネ	1
5	34269	Silicone Oil Supplying Unit (SP Unit)	S P 装置 (組)	1
6	34274	Felt for SP Unit	S P フェルト	1
7	34244	Needle Thread Tension Disc Eyelet	調子台糸道	1
8	6543	Tension Post (Short)	糸調子棒	1
9	340	Nut for 6543	糸調子棒ナット	1
10	35837	Thread Tension Spring Retainer, Complete Set	渦巻キバネキャップ (下) (組)	4
11	34774	Thread Tension Spring Cap	渦巻キバネキャップ (上)	4
12	286	Felt for 31111	フェルト	4
13	31111	Tension Disc	糸調子皿	4
14	32971	Needle Thread Tension Spring	渦巻キバネ (大)	2
15	33890	Tension Spring Bushing	糸調子ナット回り止め	4
16	34321	Needle Thread Pull-Off	針糸繰り	1
17	35799	Suction Pipe, Complete Set	吸込管 (組)	1
18	35798	Suction Pipe	吸込管	1
19	33907	Trimming Knife (Lower)	下刃	1
20	33456	Trimming Knife (Upper)	上刃	1
21	33912	Trimming Knife (Upper) Guide	上刃ガイド	1
22	5036	Screw for 33456	上刃止ネジ	1
23	34683	Trimming Knife Spring	下刃バネ	1
24	33459	Trimming Knife Holder Pin	刃支持ピン	1
25	1228	Screw for 33459	刃支持ピン止ネジ	1
26	33911	Trimming Knife Reinforced Spring	下刃圧着バネ	1
27	4237	Screw for 33911	下刃圧着バネ止ネジ	1
28	35795	Suction Pipe Holder (Upper)	吸込管支工 (上)	1
29	35796	Suction Pipe Holder (Lower)	吸込管支工 (下)	1
30	4353	Screw for 35798	吸込管止ネジ	1
31	7609	Screw for 35795, 35796	吸込管支工止ネジ	2

DCZ-438, 440 EXCLUSIVE PARTS (4)

サブクラス専用部品

DCZ-438

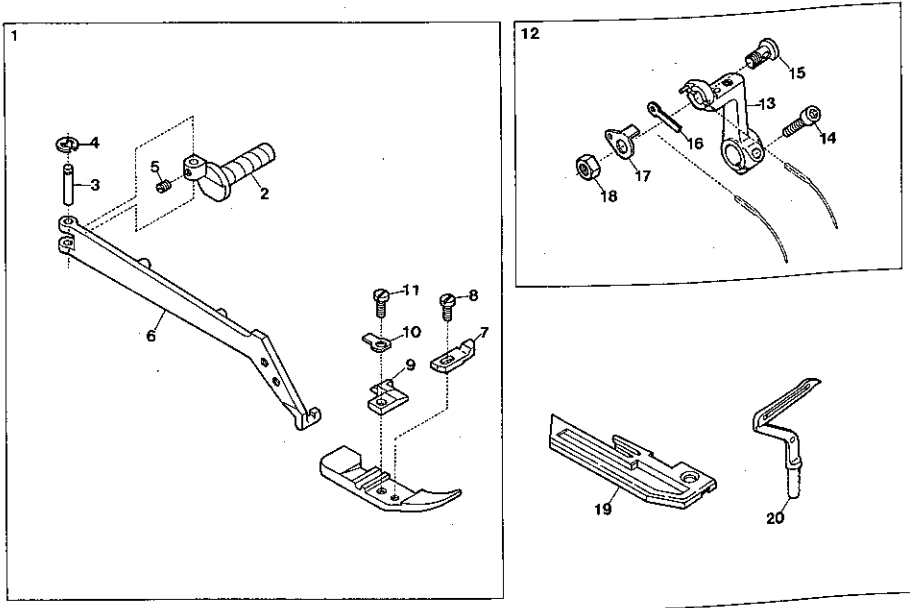

DCZ-440

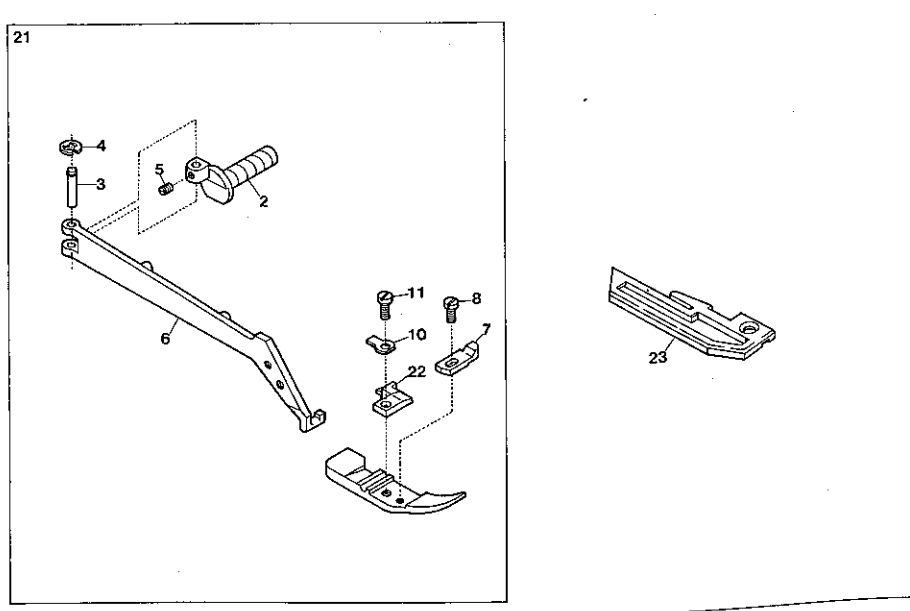

Ref. No.	Parts No.	Description	品名	Amt. Req.
1	34473	Presser Foot, Complete Set	押工(組)	1
2	35791	Presser Arm Shaft	押工軸	1
3	34290	Presser Arm Hinge Pin	押工台ヒンジピン	1
4	34293	Presser Arm Hinge Pin Retaining Ring	ストップリング	1
5	1892	Screw for 34290	押工台ヒンジピン止ネジ	1
6	35873	Presser Arm	押工台	1
7	35891	Presser Foot Fabric Guard	押工チップ	1
8	1228	Screw for 35891	押工チップ止ネジ	1
9	35874	Presser Foot Stitch Tongue	爪	1
10	30619	Presser Foot Hinge Spring	押工ヒンジバネ	1
11	5036	Screw for 30619	押工ヒンジバネ止ネジ	1
12	34402	Needle Driving Arm, Complete Set	針振り腕(組)	1
13	34322	Needle Driving Arm	針振り腕	1
14	5550	Screw for 34322	針振り腕止ネジ	1
15	34241	Needle Clamp Stud	針止メビン	1
16	34323	Needle Holder Plate	針決メ板	1
17	34324	Needle Clamp Washer	針押工	1
18	355	Nut for 34241	針止メビンナット	1
19	35856	Throat Plate	針板	1
20	34393	Lower Looper	下ルーバー	1
21	34457	Presser Foot, Complete Set	押工(組)	1
22	35843	Presser Foot Stitch Tongue	爪	1
23	35830	Throat Plate	針板	1