

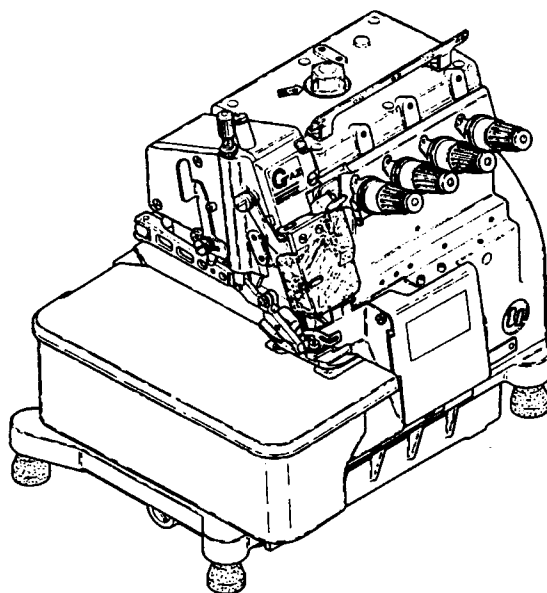

**ILLUSTRATED SPARE PARTS LIST  
FOR  
HIGH SPEED  
OVERLOCK STITCH MACHINE**



**MODELS & DEVICES**

---

**AZ6020G**

**AZ6003G**

**AZ6016G**

---

**- K2 - C -**

## パーツリストの見方

このパーツリストはAZ6020G-Y5(平メス装備)を基本モデルにしてイラストを作成しています。  
項目1~13には基本モデルを記載しています。  
項目14~サブモデル、付帯装置等を記載しています。  
パーツリストに記載されているカラーの寸法は内径×外径×幅を表わしています。

### 記号の説明(Parts No. の隣に記載されています。)

[ ] 前回のパーツリストに対して、今回変更された部品を表わしています。

[ ]内は旧Parts No. 及びネジ類の形状

◆ 前回のパーツリストに対して、今回追加された部品及びモデルを表わしています。

### 部品注文の際のご注意

☆ このパーツリストに記載されている部品をご注文の際は、Parts No. (例えば、2150210) でお願ひします。

☆ 0020004の場合は、0020004又は20004でご注文下さい。

☆ エアチューブ御注文の際は品番と長さをお知らせ下さい。

なお、このパーツリストの記載事項は、改良により変更される場合がありますのでご了承下さい。

---

## How to use this Parts List

The illustrations on this Parts List are drawn on the basis of AZ6020G-Y5 with Flat Knife.

The items from No.1 to No.13 contain the standard model.

The following items included No.14 contain the submodel and Devices.

The dimension of Collar on this Parts List shows Inside diameter × Outside diameter × Width.

### Explanation of Marks (marked at the side of Part No.)

[ ] means this part is changed from the previous Parts List.

Inside of [ ] shows the previous Part No. and the shape of screw or the like.

◆ means this part and model is added to the previous Parts List.

### How to place an order for the parts

☆ When placing an order for the parts from this Parts List, please clearly state the Parts No. (e.g.2150210) which you require so that we can deliver the correct parts to you.

☆ When the Part No. is "0020004", please place an order for the part by showing "0020004" or "20004".

☆ When ordering Air Tube, please inform us of the Part No. and the length.

This Parts List is subject to change without notice.

# CONTENTS

# 目 次

MISCELLANEOUS COVERS (1) . . . . .	カバー関係 (1) . . . . .	1
"    "    (2) . . . . .	"    (2) . . . . .	2
"    "    (3) . . . . .	"    (3) . . . . .	3
MISCELLANEOUS THREAD EYELETS . . . . .	糸道関係 . . . . .	4
MISCELLANEOUS CRANKSHAFT & BUSHINGS . . . . .	主軸及びブッシュ関係 . . . . .	5
NEEDLE BAR DRIVING MECHANISM . . . . .	針棒機構 . . . . .	6
KNIFE DRIVING MECHANISM . . . . .	メス機構 . . . . .	7
PRESSER FOOT MECHANISM . . . . .	押エ機構 . . . . .	8
UPPER LOOPER DRIVING MECHANISM . . . . .	上ルーパ機構 . . . . .	9
LOWER LOOPER DRIVING MECHANISM . . . . .	下ルーパ機構 . . . . .	10
FEED DRIVING CONTROL MECHANISM . . . . .	前送り調節機構 . . . . .	11
FEED DRIVING MECHANISM . . . . .	送り機構 . . . . .	12
LUBRICATING MECHANISM . . . . .	給油機構 . . . . .	13
EXCLUSIVE PARTS for UPPER KNIFE (Angled Type), AZ6003G . . . . .	角メス及びサブモデル専用部品 . . . . .	14
AZ6016G EXCLUSIVE PARTS . . . . .	サブモデル専用部品 . . . . .	15
"K2" DEVICE (1) . . . . .	"K2"装置 (1) . . . . .	16
"    "    (2) . . . . .	"    "    (2) . . . . .	17
"C" DEVICE . . . . .	"C"装置 . . . . .	18
MISCELLANEOUS SUPPORTING BOARD . . . . .	受け板関係 . . . . .	19
THREAD STAND . . . . .	糸立台 . . . . .	20
WARNING LABEL . . . . .	警告ラベル . . . . .	21
LIST of MAIN SPARE PARTS . . . . .	主要部品リスト . . . . .	22
INDEX . . . . .	索引 . . . . .	23

1

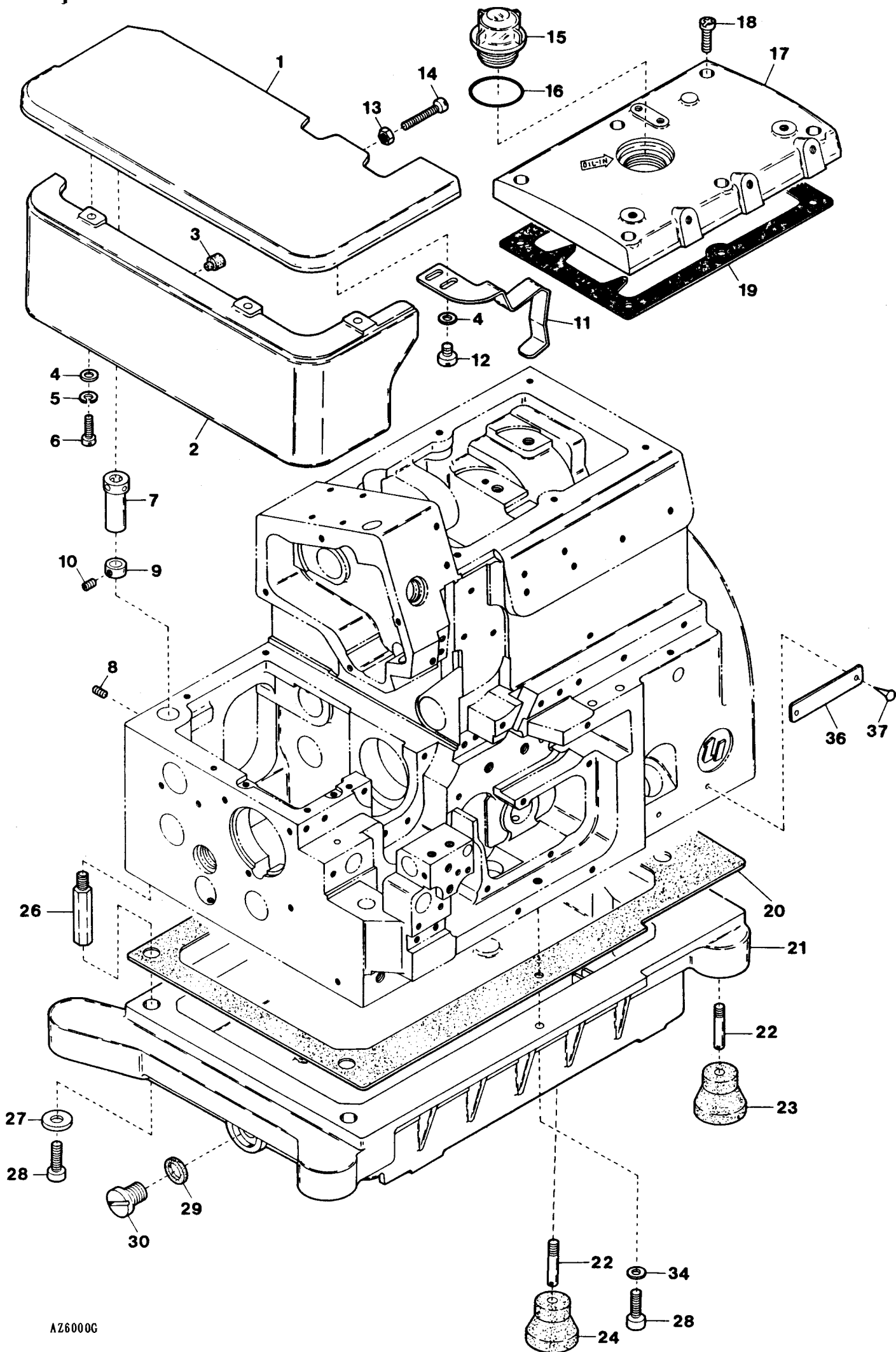

MISCELLANEOUS COVERS (1)

カバー関係(1)

Ref. No.	Parts No.	Description	品名	Amt. Req.
1	2100006	Cloth Plate	クロスプレート	1
2	2150210	Cloth Plate (Lower)	クロスプレート(下)	1
3	2100014	Rubber Cushion	クロスプレート(下)埋メ座	1
4	001123	Washer	ワッシャ	5
5	000644	Spring Washer	スプリングワッシャ	3
6	110045	Screw(M4-0.7×12)	止ネジ	3
7	2100011	Cloth Plate Eccentric Bushing	エキセンブッシュ	1
8	160001	Screw(M4-0.7×4)	止ネジ	1
9	2100012	Collar(4×9×6mm)	カラー	1
10	003637	Screw(1/8-44×2.5)	止ネジ	1
11	2150015	Cloth Plate Spring	クロスプレートバネ	1
12	110012	Screw(M4-0.7×5)	止ネジ	2
13	100001	Lock Nut	ロックナット	1
14	110031	Stop Screw(M4-0.7×12)	ストップネジ	1
15	0020004	Oil Cap	オイルキャップ	1
16	0020005	O-ring(P28)	Oリング	1
17	2100053	Top Cover	上カバー	1
18	110016	Screw(M4-0.7×15)	止ネジ	6
19	2150026	Top Cover Gasket	上カバーパッキン	1
20	2100864	Oil Reservoir Gasket	油受ケパッキン	1
21	2100863	Oil Reservoir	油受ケ	1
22	006816	Screw(1/4-24×8)	止ネジ	4
23	0032879	Oil Reservoir Rubber Cushion(Black-colored)	防振ゴム(黒色)	3
24	0033627	Oil Reservoir Rubber Cushion(Green-colored)	防振ゴム(緑色)	1
25	.....	.....	.....	.....
26	2100875	Oil Reservoir Positioning Bar	油受ケ固定棒	4
27	300004	Washer	ワッシャ	4
28	120017	Screw(M5-0.8×15)	止ネジ	6
29	0020137	Drain Hole Seal	パッキン	1
30	005075	Drain Hole Screw(3/8-24×8)	油抜キネジ	1
31	.....	.....	.....	.....
32	.....	.....	.....	.....
33	.....	.....	.....	.....
34	300043	Washer	ワッシャ	2
35	.....	.....	.....	.....
36	2049401	Serial Number Plate	機板プレート	1
37	000726	Rivet	止メ鋸	2

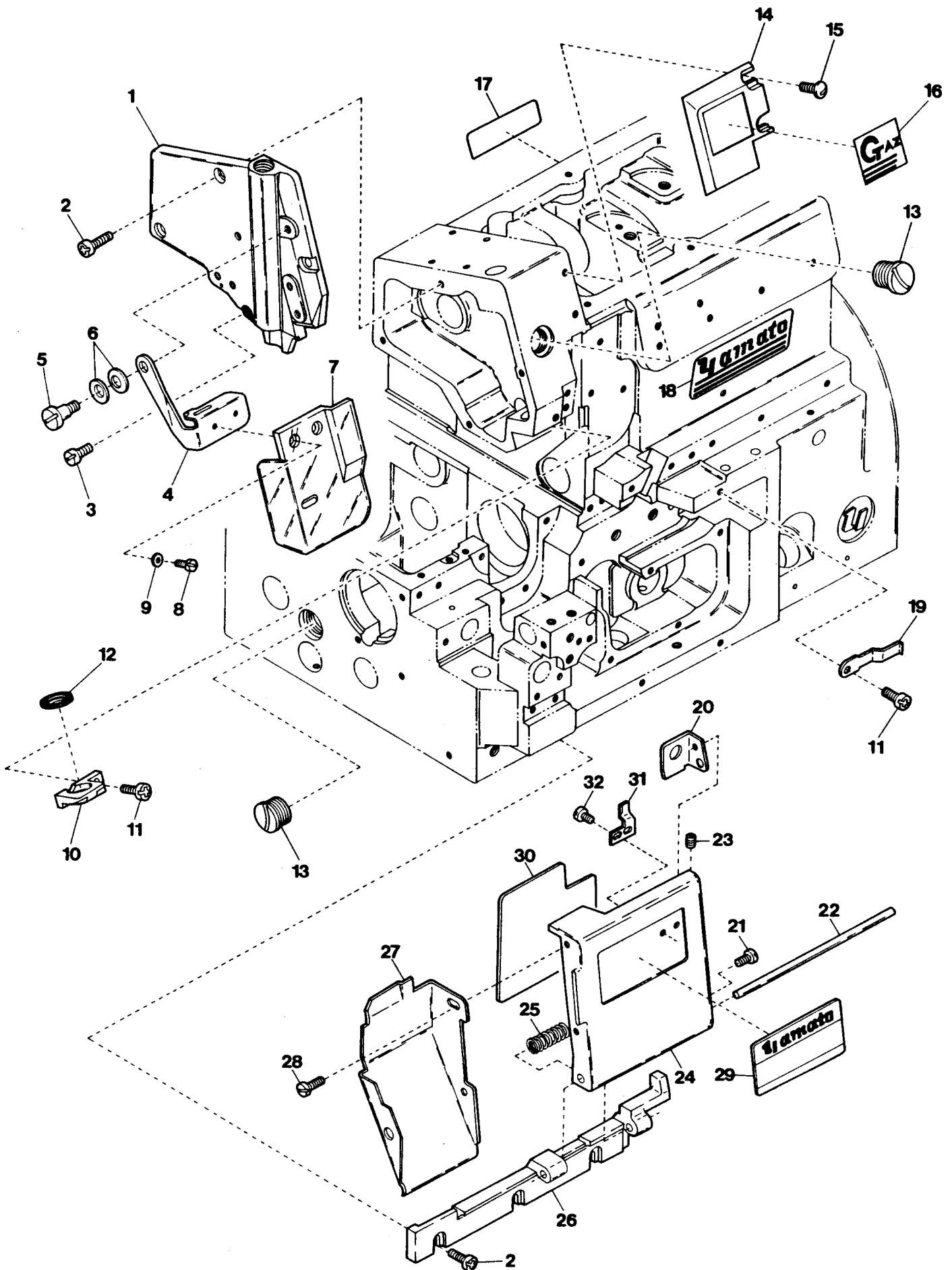

**MISCELLANEOUS COVERS (2)**

**カバー関係(2)**

**2**

Ref. No.	Parts No.	Description	品名	Amt. Req.
1	2150016	Side Cover . . . . .	側面カバー . . . . .	1
2	110013	Screw(M4-0.7×8) . . . . .	止ネジ . . . . .	5
3	110001	Screw(M4-0.7×5.4) . . . . .	止ネジ . . . . .	1
4	2150018	Eye Guard Holder . . . . .	アイガード板 . . . . .	1
5	170032	Screw(M4-0.7×5) . . . . .	止ネジ . . . . .	1
6	000010	Conical Spring Washer . . . . .	皿バネワッシャ . . . . .	2
7	2150125	Eye Guard . . . . .	アイガード . . . . .	1
8	110076	Screw(M3-0.5×6) . . . . .	止ネジ . . . . .	2
9	000444	Washer . . . . .	ワッシャ . . . . .	2
10	2150023	Needle Bar Oil Defender . . . . .	針棒油受ケ . . . . .	1
11	110012	Screw(M4-0.7×5) . . . . .	止ネジ . . . . .	2
12	2150024	Needle Bar Oil Seal . . . . .	針棒シール . . . . .	1
13	190015	Screw(M14-2×6) . . . . .	止ネジ . . . . .	2
14	2150025	Logo Plate . . . . .	ロゴマーク板 . . . . .	1
15	110106	Screw(M4-0.7×8) . . . . .	止ネジ . . . . .	2
16	390177	"AZ-G" Logo Mark . . . . .	A Z - G ロゴマーク . . . . .	1
17	390098	Brand Name Plate(68mm)(Red) . . . . .	銘板(赤) . . . . .	1
18	390097	Brand Name Plate(83mm)(Red) . . . . .	銘板(赤) . . . . .	1
19	2100538	Front Cover Latch Spring . . . . .	前開キカバーラッチバネ . . . . .	1
20	0024446	Front Cover Hook . . . . .	前開キカバーフック . . . . .	1
21	001203	Screw(9/64-40×4.5) . . . . .	止ネジ . . . . .	1
22	0020016	Front Cover Hinge Pin . . . . .	前開キカバーヒンジピン . . . . .	1
23	003637	Screw(1/8-44×2.5) . . . . .	止ネジ . . . . .	2
24	2100024	Front Cover(Right) . . . . .	前開キカバー . . . . .	1
25	0024095	Front Cover Hinge Spring . . . . .	前開キカバーヒンジバネ . . . . .	1
26	2100855	Front Cover Hinge . . . . .	前開キカバーヒンジ . . . . .	1
27	2100534	Chip Guard(Openable) . . . . .	切屑落シ板 . . . . .	1
28	110003	Screw(M3.5-0.6×6) . . . . .	止ネジ . . . . .	2
29	2129423	Model Plate(Red) . . . . .	型式板(赤) . . . . .	1
30	----	Threading Chart(See the Table) . . . . .	糸通シ図(下表参照) . . . . .	1
31	2100856	Front Cover Latch . . . . .	前開キカバーラッチ . . . . .	1
32	110054	Screw(M3-0.5×3.5) . . . . .	止ネジ . . . . .	2

(注) 型式板を御注文の際は機種名(ゲージ記号, 付帯装置含む)をお知らせ下さい。  
 Note : Order for Model Plate must be accompanied by model designation(including symbols of gauge and devices).

Models	Parts No. Threading Chart
AZ6003G	390650
6016G	390650
6020G	390651

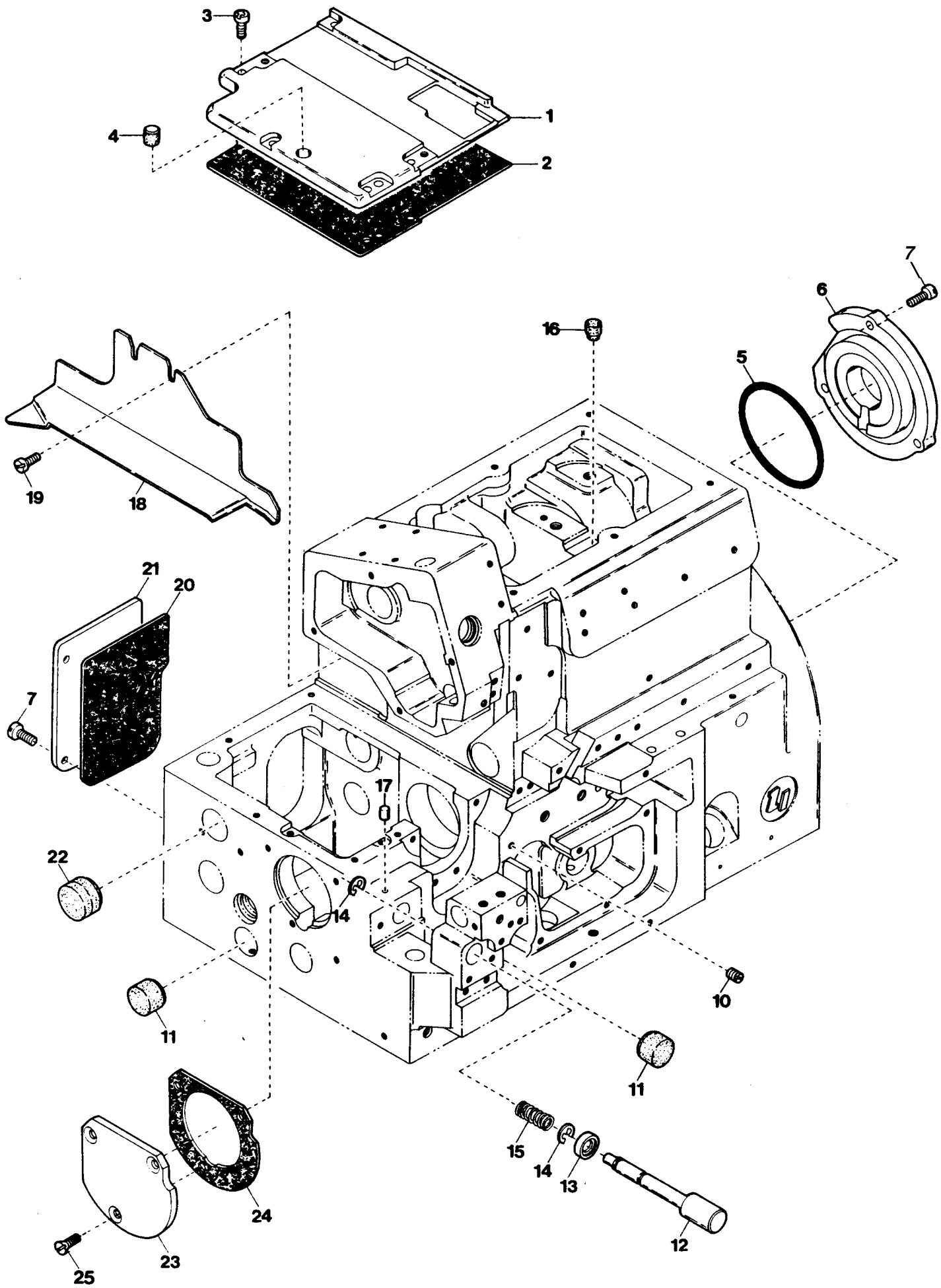



MISCELLANEOUS COVERS (3)

カバー関係 (3)

3

Ref. No.	Parts No.	Description	品名	Amt. Req.
1	2100035	Feed Mechanism Cover . . . . .	送り上カバー . . . . .	1
2	2100921	Feed Mechanism Cover Gasket . . . . .	送り上カバーパッキン . . . . .	1
3	110048	Screw(M4-0.7×10) . . . . .	止ネジ . . . . .	5
4	2100047	Rubber Cushion . . . . .	埋メ座(中) . . . . .	1
5	2110027	O-ring(P52) . . . . .	Oリング . . . . .	1
6	2110026	Ball Bearing Holder . . . . .	ベアリング押エ . . . . .	1
7	110013	Screw(M4-0.7×8) . . . . .	止ネジ . . . . .	7
8	.	.	.	.
9	.	.	.	.
10	150004	Screw(M4-0.7×6) . . . . .	止ネジ . . . . .	1
11	2100961	Seal Plug . . . . .	詰栓 . . . . .	2
12	2150022	Pushbutton . . . . .	プッシュボタン . . . . .	1
13	2100861	Oil Seal . . . . .	オイルシール . . . . .	1
14	0033024	Retaining Ring . . . . .	ストップリング . . . . .	2
15	0068517	Pushbutton Spring . . . . .	プッシュボタンバネ . . . . .	1
16	330008	Seal Plug . . . . .	詰栓 . . . . .	1
17	330000	Seal Plug . . . . .	詰栓 . . . . .	1
18	2150017	Fabric Guide Plate . . . . .	布案内板 . . . . .	1
19	110064	Screw(M4-0.7×8) . . . . .	止ネジ . . . . .	2
20	2100918	Tail Cover Gasket . . . . .	後カバーパッキン . . . . .	1
21	2100037	Tail Cover . . . . .	後カバー . . . . .	1
22	0036518	Seal Plug . . . . .	詰栓 . . . . .	1
23	2100873	Ball Bearing Housing . . . . .	ハウジング . . . . .	1
24	2100874	Ball Bearing Housing Gasket . . . . .	ハウジングパッキン . . . . .	1
25	130003	Screw(M4-0.7×7.3) . . . . .	止ネジ . . . . .	3

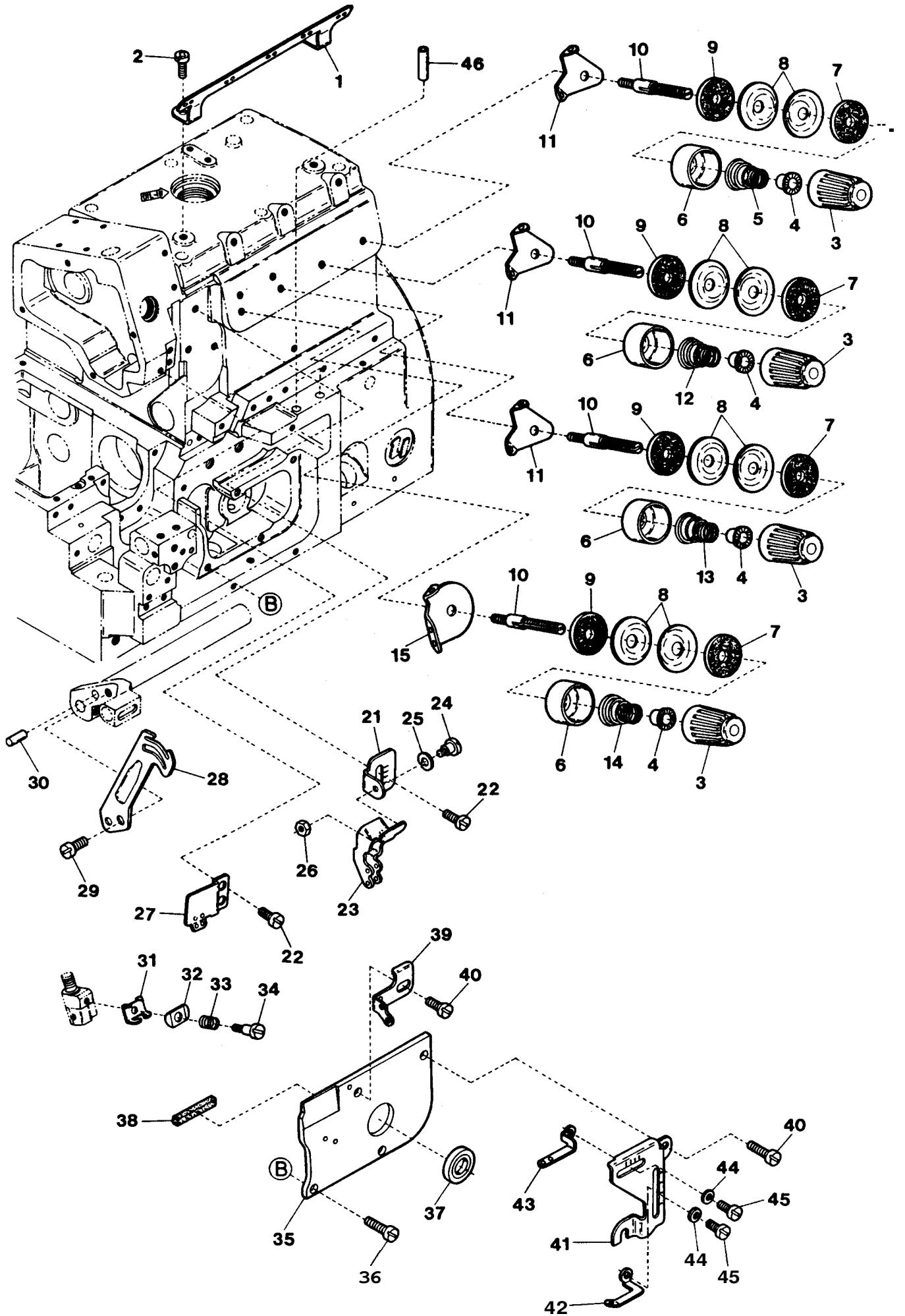

MISCELLANEOUS THREAD EYELETS

糸道関係

4

Ref.	Parts	Description	品名	Amt. Req.
1	2100063	Thread Guide Plate . . . . .	糸案内板 . . . . .	1
2	110013	Screw(M4-0.7×8) . . . . .	止ネジ . . . . .	2
3	0024084	Thread Tension Spring Cap . . . . .	糸調子バネキャップ(上) . . . . .	4
4	0024083	Tension Spring Bushing . . . . .	糸調子ナット回り止メ . . . . .	4
5	0024157	Lower Looper Thread Tension Spring . . . . .	下ルーパ糸調子バネ . . . . .	1
6	0020118	Thread Tension Spring Retainer . . . . .	糸調子バネキャップ(下) . . . . .	4
7	000178	Felt . . . . .	フェルト . . . . .	4
8	0031111	Tension Disc . . . . .	糸調子皿 . . . . .	8
9	000177	Felt . . . . .	フェルト . . . . .	4
10	190016	Tension Post(Short) . . . . .	糸調子棒(短) . . . . .	4
11	0032962	Tension Disc Eyelet . . . . .	糸調子台糸道 . . . . .	3
12	0032952	Upper Looper Thread Tension Spring . . . . .	上ルーパ糸調子バネ . . . . .	1
13	0032971	Needle Thread Tension Spring . . . . .	針糸調子バネ . . . . .	1
14	0024156	Needle Thread Tension Spring . . . . .	針糸調子バネ . . . . .	1
15	2150116	Tension Disc Eyelet for Needle Thread . . . . .	針糸調子台糸道 . . . . .	1
16	.	.	.	.
17	.	.	.	.
18	.	.	.	.
19	.	.	.	.
20	.	.	.	.
21	2150124	Needle Thread Eyelet Holder . . . . .	針糸道取付板 . . . . .	1
22	110001	Screw(M4-0.7×5.4) . . . . .	止ネジ . . . . .	3
23	2150115	Needle Thread Eyelet(Right) . . . . .	針糸道(右) . . . . .	1
24	006035	Screw(9/64-40×7) . . . . .	止ネジ . . . . .	1
25	000644	Spring Washer . . . . .	スプリングワッシャ . . . . .	1
26	000322	Nut . . . . .	ナット . . . . .	1
27	2150114	Needle Thread Eyelet(Left) . . . . .	針糸道(左) . . . . .	1
28	2150110	Needle Thread Pull-off . . . . .	針糸繰り . . . . .	1
29	110073	Screw(M4-0.7×7.5) . . . . .	止ネジ . . . . .	1
30	000653	Knock Pin . . . . .	ノックピン . . . . .	1
31	2150111	Thread Retainer Plate Support . . . . .	小調子板 . . . . .	1
32	2150112	Thread Retainer Plate . . . . .	小調子皿 . . . . .	1
33	2150132	Thread Retainer Spring . . . . .	小調子皿バネ . . . . .	1
34	170049	Screw(M2-0.4×4) . . . . .	止ネジ . . . . .	1
35	2150027	Looper Holder Cover . . . . .	ルーパ台カバー . . . . .	1
36	110009	Screw(M4-0.7×8) . . . . .	止ネジ . . . . .	1
37	0093303	Looper Driving Shaft Oil Seal . . . . .	ルーパ軸オイルシール . . . . .	1
38	2100229	Looper Holder Cover Spacer(Rubber) . . . . .	ルーパ台カバースペーサ . . . . .	1
39	2150119	Looper Thread Eyelet(Left) . . . . .	ルーパ糸道(左) . . . . .	1
40	110035	Screw(M4-0.7×10) . . . . .	止ネジ . . . . .	3
41	2150123	Thread Eyelet Support . . . . .	糸道取付板 . . . . .	1
42	2150120	Lower Looper Thread Eyelet . . . . .	下ルーパ糸道 . . . . .	1
43	2150121	Upper Looper Thread Eyelet . . . . .	上ルーパ糸道 . . . . .	1
44	000014	Washer . . . . .	ワッシャ . . . . .	2
45	110026	Screw(M3-0.5×6) . . . . .	止ネジ . . . . .	2
46	0022215	Looper Thread Pipe . . . . .	糸道パイプ . . . . .	2

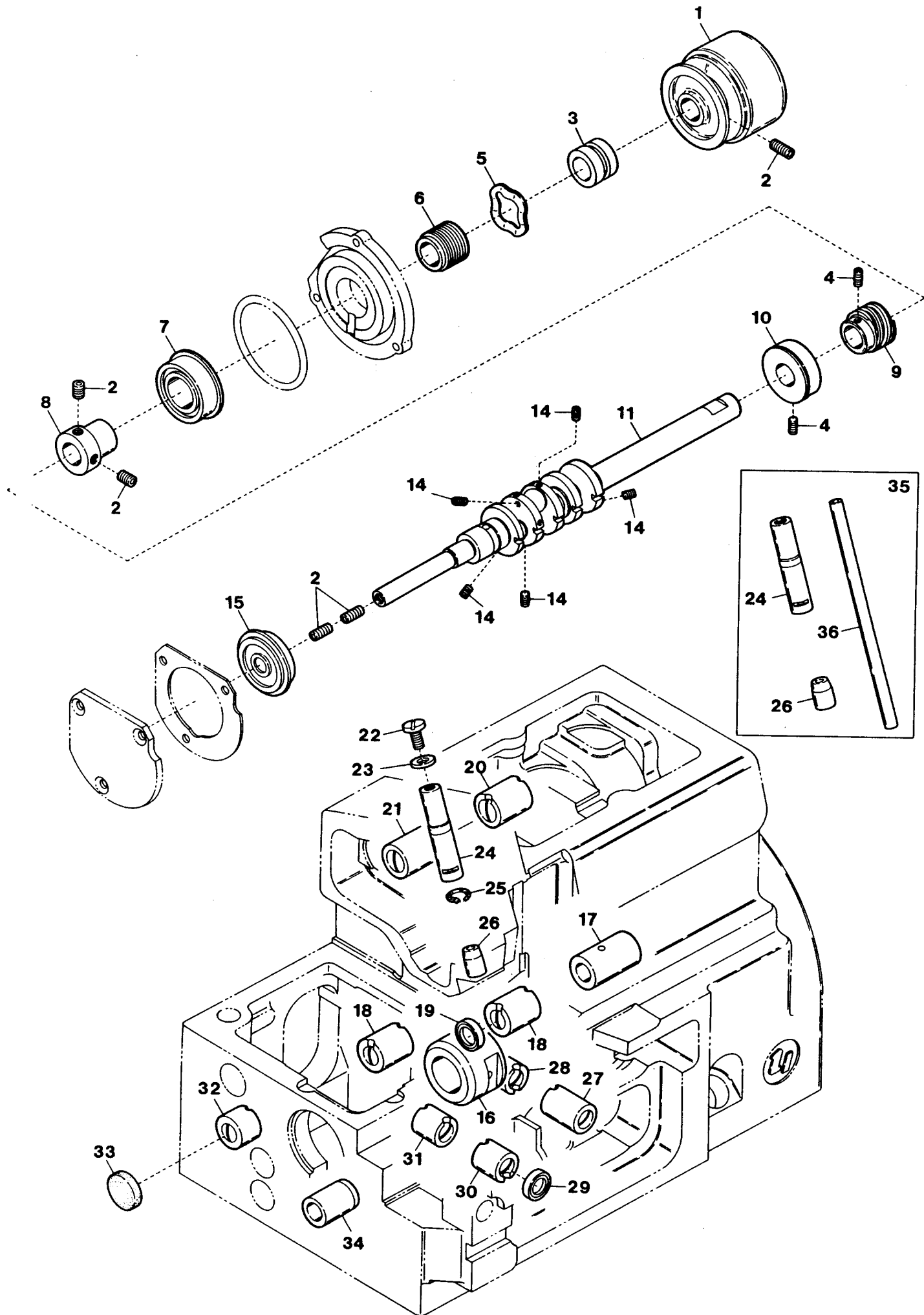

MISCELLANEOUS CRANKSHAFT & BUSHINGS

主軸及びブッシュ関係

5

Ref. No.	Parts No.	Description	品名	Amt. Req.
1	2150214	Machine Pulley	ミシンプーリ	*1
2	160007	Screw (M6-1×6)	止ネジ	5
3	2100625	Mechanical Oil Shield Sleeve	油切リスリーブ	1
4	160001	Screw (M4-0.7×4)	止ネジ	3
5	2110184	Corrugeted Washer	波形ワッシャ	1
6	2110183	Mechanical Oil Shield	油切り	1
7	0093090	Crankshaft Ball Bearing (Right)	ボールベアリング(右)	1
8	3100129	Bearing Adapter	ベアリング受け	1
9	2150096	Oil Pump Driving Worm.	ウォーム	1
10	2150038	Crankshaft Bushing	中ブッシュ	1
11	2150100	Crankshaft	クランクシャフト	1
12				
13				
14	160027	Screw (M3-0.5×3)	詰ネジ	5
15	2100872	Crankshaft Ball Bearing (Left)	ボールベアリング(左)	1
16	2150039	Crankshaft Bushing	小ブッシュ	1
17	2100105	Upper Knife Driving Shaft Bushing (Right)	上メス軸ブッシュ(右)	1
18	2150043	Upper Knife Feed Bar Driving Shaft Bushing	上メス軸送り軸ブッシュ	2
19	2100117	Upper Knife Driving Shaft Oil Seal	上メス軸オイルシール	1
20	2150049	Needle Bar Driving Shaft Bushing (Right)	針棒クランク軸ブッシュ(右)	1
21	2150048	Needle Bar Driving Shaft Bushing (Left)	針棒クランク軸ブッシュ(左)	1
22	003636	Cap Screw (5/16-32×3.5)	蓋ネジ	1
23	000526	Gasket	パッキン	1
24	2150040	Needle Bar Bushing (Upper)	針棒ブッシュ(上)	1
25	310109	Oil Wick	油芯	1
26	2150041	Needle Bar Bushing (Lower)	針棒ブッシュ(下)	1
27	2150046	Upper Looper Driving Shaft Bushing (Front)	上ルーパ軸ブッシュ(前)	1
28	2150047	Upper Looper Driving Shaft Bushing (Rear)	上ルーパ軸ブッシュ(後)	1
29	2100272	Looper Driving Shaft Oil Seal	ルーパ軸オイルシール	1
30	2150044	Lower Looper Driving Shaft Bushing (Front)	下ルーパ軸ブッシュ(前)	1
31	2150045	Lower Looper Driving Shaft Bushing (Rear)	下ルーパ軸ブッシュ(後)	1
32	2150042	Feed Bar Driving Shaft Bushing (Left)	送り軸ブッシュ(左)	1
33	2150069	Seal Plug	詰栓	1
34	2100098	Control Lever Shaft Bushing	送り調節レバー軸ブッシュ	1
35	2150050	Needle Bar & Needle Bar Bushing, C. Set	針棒・針棒ブッシュ(組)	1
36	2100642	Needle Bar	針棒	1

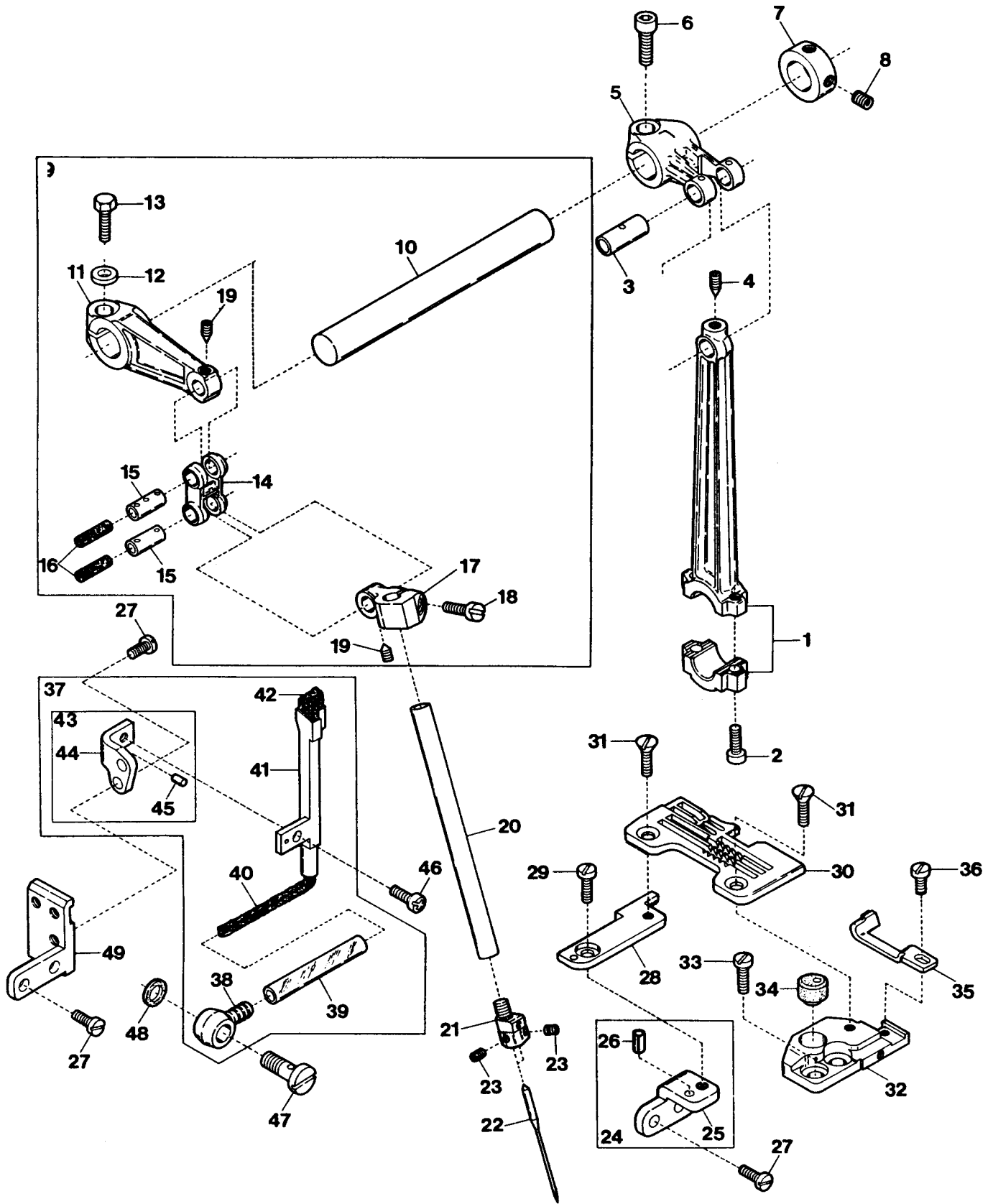

**NEEDLE BAR DRIVING MECHANISM**

**針棒機構**

**6**

Ref. No.	Parts No.	Description	品名	Amt. Req.
1	2150105	Needle Bar Driving Connecting Rod	針棒ロッド	1
2	120049	Screw(M4-0.7×16)	止ネジ	2
3	2100144	Needle Bar Driving Connecting Rod Pin	針棒クランクピン	1
4	160002	Screw(M4-0.7×5)	止ネジ	1
5	2100899	Needle Bar Driving Lever	針棒クランク軸腕	1
6	120006	Screw(M6-1×12)	止ネジ	1
7	2100137	Collar(12×20×10mm)	カラー	1
8	160003	Screw(M5-0.8×5)	止ネジ	2
9	2150510	Needle Bar Crank Arm, C. Set	針棒クランク(組)	1
10	2150500	Needle Bar Driving Shaft	針棒クランク軸	1
11	2100136	Needle Bar Crank Arm	針棒クランク	1
12	300008	Washer	ワッシャ	1
13	140003	Screw(M6-1×18)	止ネジ	1
14	2100138	Needle Bar Connecting Link	針棒リンク	1
15	2100176	Needle Bar Connecting Link Pin	針棒リンクピン	2
16	310089	Oil Wick	油芯	2
17	2150051	Needle Bar Connecting Bracket	針棒抱キ	1
18	110006	Screw(M3.5-0.6×10)	止ネジ	1
19	160016	Screw(M4-0.7×4.5)	止ネジ	2
20	2100642	Needle Bar	針棒	1
21	2159102	Needle Clamp(Y)	針止メ	1
22	-----	Needle(System:DC×1)	針	2
23	003637	Screw(1/8-44×2.5)	止ネジ	2
24	2150057	Stitch Plate Support Stay, C. Set	針板取付台支エ(組)	1
25	2150058	Stitch Plate Support Stay	針板取付台支エ	1
26	000035	Roll Pin	ロールピン	1
27	110009	Screw(M4-0.7×8)	止ネジ	6
28	2100502	Stitch Plate Support(Rear)	針板取付台(後)	1
29	110001	Screw(M4-0.7×5.4)	止ネジ	1
30	2108004	Stitch Plate(Y5)	針板	1
31	005345	Screw(11/64-40×8.3)	止ネジ	2
32	2100145	Stitch Plate Support(Front)	針板取付台(前)	1
33	110011	Screw(M5-0.8×10)	止ネジ	2
34	0032604	Rubber Cushion	埋メ座	1
35	2109200	Needle Guard(Front)	針受ケ(前)	1
36	110002	Screw(M3-0.5×5)	止ネジ	1
37	2150035	HR Unit, Complete Set	HR装置(組)	1
38	3100370	Tube Joint	パイプ継手	1
39	2100152	Oil Tube(70mm)	給油パイプ(70mm)	1
40	310005	Oil Wick	油芯	1
41	2100533	HR Felt Holder	HRフェルト受ケ	1
42	310001	HR Felt	HRフェルト	1
43	2100535	HR Felt Holder Bracket, C. Set	HR取付台(組)	1
44	2100536	HR Felt Holder Bracket	HR取付台	1
45	000393	Roll Pin	ロールピン	1
46	110013	Screw(M4-0.7×8)	止ネジ	1
47	320008	Fitting Stud(Short)	管継手ボルト(短)	1
48	000567	Seal	パッキン	1
49	2150150	HR Unit Bracket	HR装置台	1

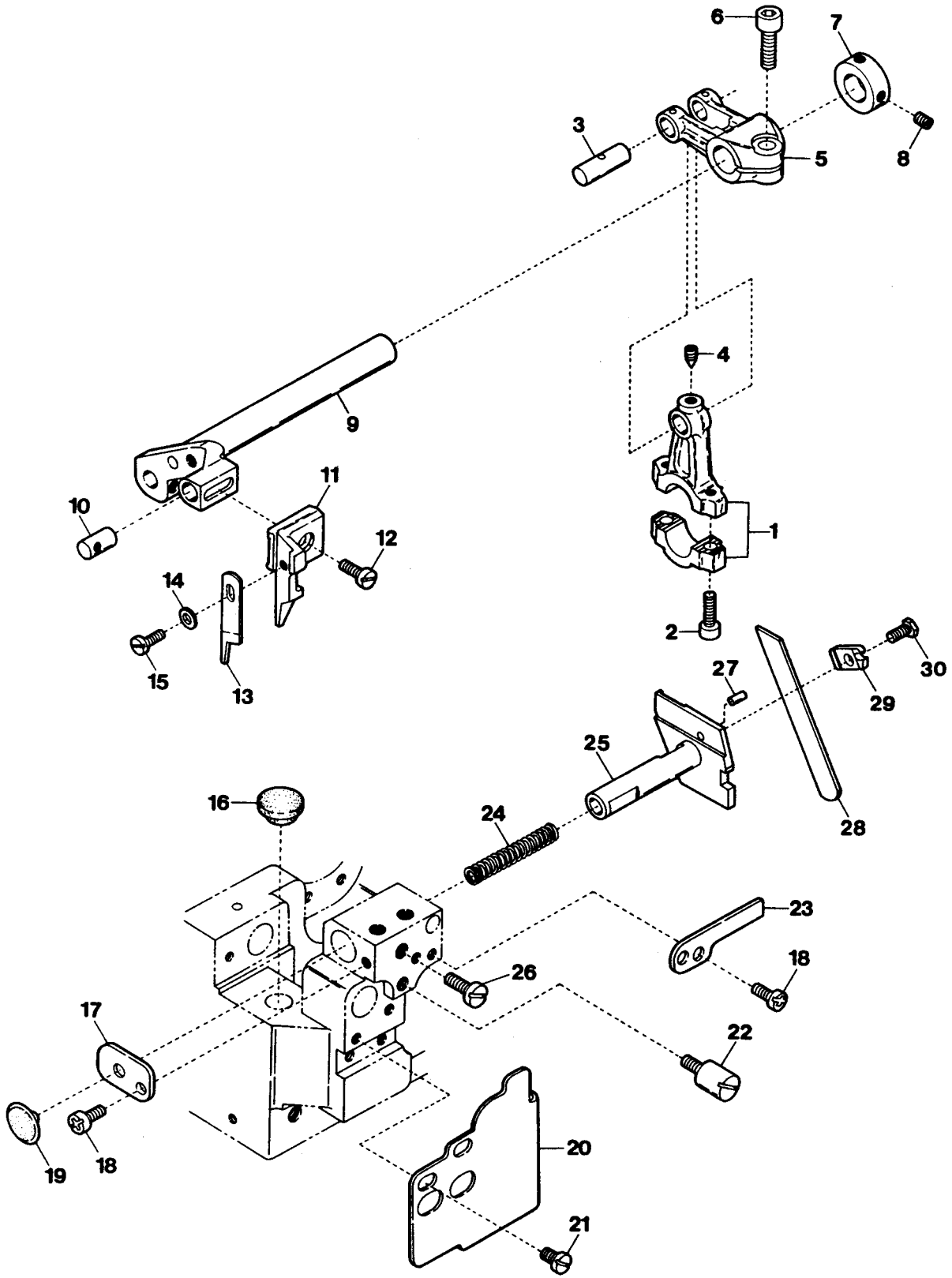



**KNIFE DRIVING MECHANISM**

**メス機構**

**7**

Ref. No.	Parts No.	Description	品名	Amt. Req.
1	2100160	Upper Knife Driving Connecting Rod	上メスロッド	1
2	120049	Screw (M4-0.7×16)	止ネジ	2
3	2100173	Driving Lever Pin	上メス軸腕ピン	1
4	160002	Screw (M4-0.7×5)	止ネジ	1
5	2100162	Upper Knife Driving Lever	上メス軸腕	1
6	120006	Screw (M6-1×12)	止ネジ	1
7	2100161	Collar (10×19×9mm)	カラー	1
8	160003	Screw (M5-0.8×5)	止ネジ	2
9	2150060	Upper Knife Driving Shaft	上メス軸	1
10	2100165	Upper Knife Holder Positioner	上メスホルダピン	1
11	2100164	Upper Knife Holder (Flat Type)	上メスホルダ(平)	1
12	110035	Screw (M4-0.7×10)	止ネジ	1
13	0020496	Upper Knife (Flat Type)	上メス(平)	1
14	000532	Washer	ワッシャ	1
15	110004	Screw (M3.5-0.6×8)	止ネジ	1
16	0093864	Seal Plug	詰栓	1
17	2150020	Lower Knife Holder Spring Stop	下メスバネ受ケ	1
18	110012	Screw (M4-0.7×5)	止ネジ	3
19	2100174	Cloth Plate Rubber Cushion	緩衝ゴム	1
20	2150019	Front Cover	前カバー	1
21	110001	Screw (M4-0.7×5.4)	止ネジ	2
22	2100009	Cloth Plate Spring Pin	バネ受ケピン	1
23	2150021	Lower Knife Holder Locking Plate	下メス台回り止め	1
24	0032919	Lower Knife Holder Spring	下メスバネ	1
25	2100166	Lower Knife Holder	下メス台	1
26	110046	Screw (M5-0.8×12)	止ネジ	1
27	000688	Guide Pin	ガイドピン	1
28	2100167	Lower Knife	下メス	1
29	2100168	Lower Knife Clamp	下メス押エ	1
30	140014	Screw (M4-0.7×8)	止ネジ	1

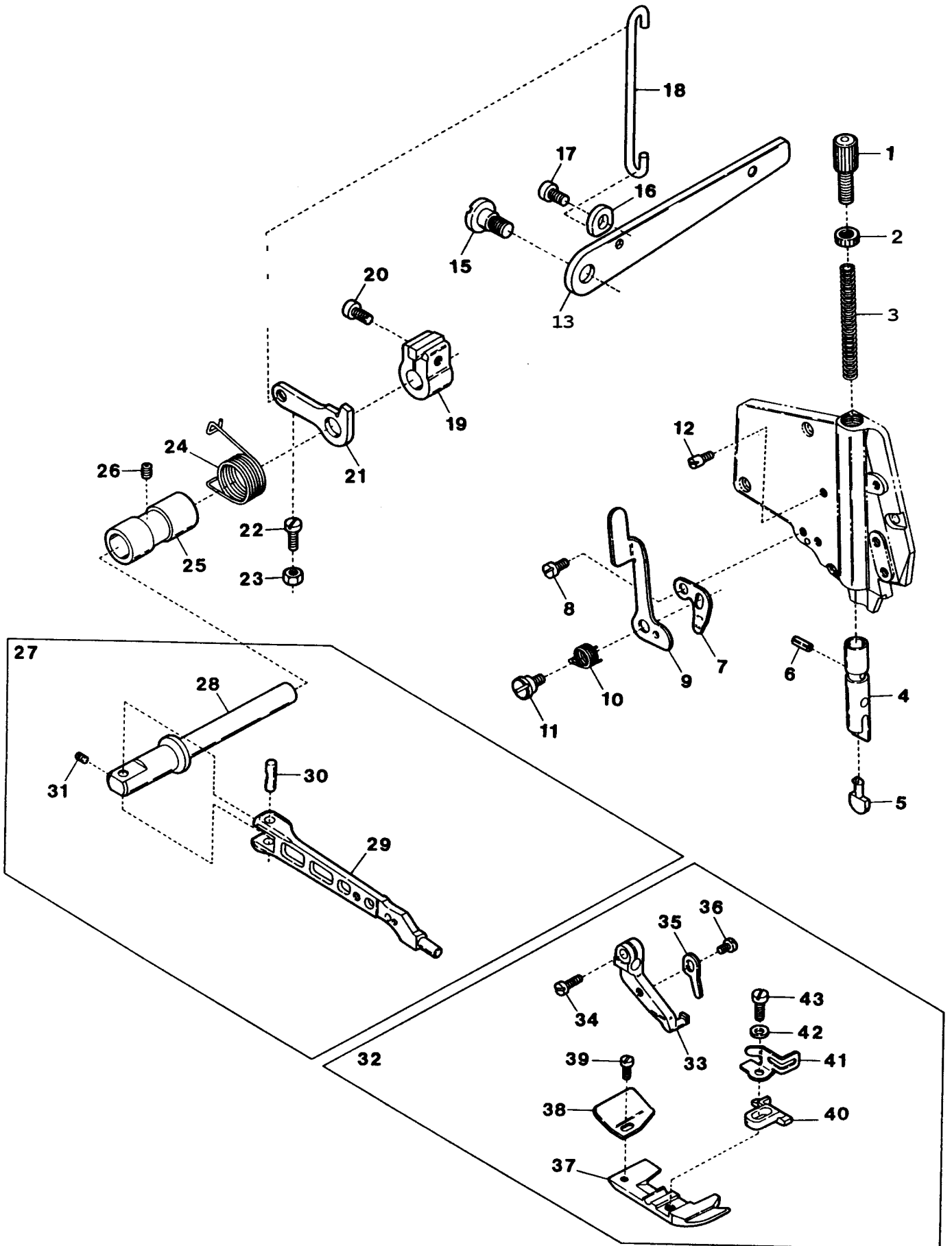

**PRESSER FOOT ECHANISM**

**押工機構**

Ref. No.	Parts No.	Description	品名	Amt. Req.
1	190080	Adjusting Screw(M10-0.75×30)	調節ネジ	1
2	100073	Lock Nut	ロックナット	1
3	2100181	Presser Spring	押エバネ	1
4	2150145	Presser Bar	押エ棒	1
5	2100580	Presser Am Positioning Guide Pin	押エ腕案内ピン	1
6	000482	Spring Pin	スプリングピン	1
7	2150146	Presser Am Stop	押エ腕ストッパ	1
8	110012	Screw(M4-0.7×5)	止ネジ	1
9	2150147	Presser Foot Release Lever	手揚げ	1
10	2150148	Presser Foot Release Lever Spring	手揚げバネ	1
11	170045	Screw(M4-0.7×5)	止ネジ	1
12	180001	Screw(M4-0.7×4.5)	バネ掛ケネジ	1
13	2100193	Presser Foot Lifter Lever	押エ揚げレバー	1
14				
15	170047	Screw(M8-1.25×10)	止ネジ	1
16	2150138	Presser Foot Lifter Lever Stop	押エ揚げレバーストッパ	1
17	120010	Screw(M6-1×10)	止ネジ	1
18	2100197	Presser Foot Lifter Lever Link	押エ揚げレバーリンク	1
19	2100518	Presser Foot Shaft Collar	押エ軸カラー	1
20	120017	Screw(M5-0.8×15)	止ネジ	1
21	2100192	Intermediate Lever	押エ軸レバー	1
22	110065	Stop Screw(M4-0.7×12)	ストップネジ	1
23	100001	Lock Nut	ロックナット	1
24	2150139	Presser Foot Lifter Lever Spring	押エ揚げレバーバネ	1
25	2100099	Presser Foot Shaft Bushing	押エ軸ブッシュ	1
26	160007	Screw(M6-1×6)	止ネジ	1
27	2150140	Presser Arm, Complete Set	押エ腕(組)	1
28	2100189	Presser Foot Shaft	押エ軸	1
29	2150141	Presser Arm	押エ腕	1
30	2100199	Presser Arm Hinge Pin	押エ腕ヒンジピン	1
31	160001	Screw(M4-0.7×4)	止ネジ	1
32	2157057	Presser Foot, C. Set(Y5)	押エ(組)	1
33	2157000	Presser Foot Hinge	押エヒンジ	1
34	110004	Screw(M3.5-0.6×8)	止ネジ	1
35	2157040	Presser Foot Half-stay	半固定片	1
36	110050	Screw(M3.5-0.6×4.5)	止ネジ	1
37	2157020	Presser Foot(Lower)	押エ(下)	1
38	0034535	Thread Chain Guide	空環ガイド	1
39	004237	Screw(3/32-56×2.6)	止ネジ	1
40	2157205	Presser Foot Stitch Tongue(Y5)	爪	1
41	2107643	Finger Guard	フィンガガード	1
42	000444	Washer	ワッシャ	1
43	005036	Screw(1/8-44×5.6)	止ネジ	1

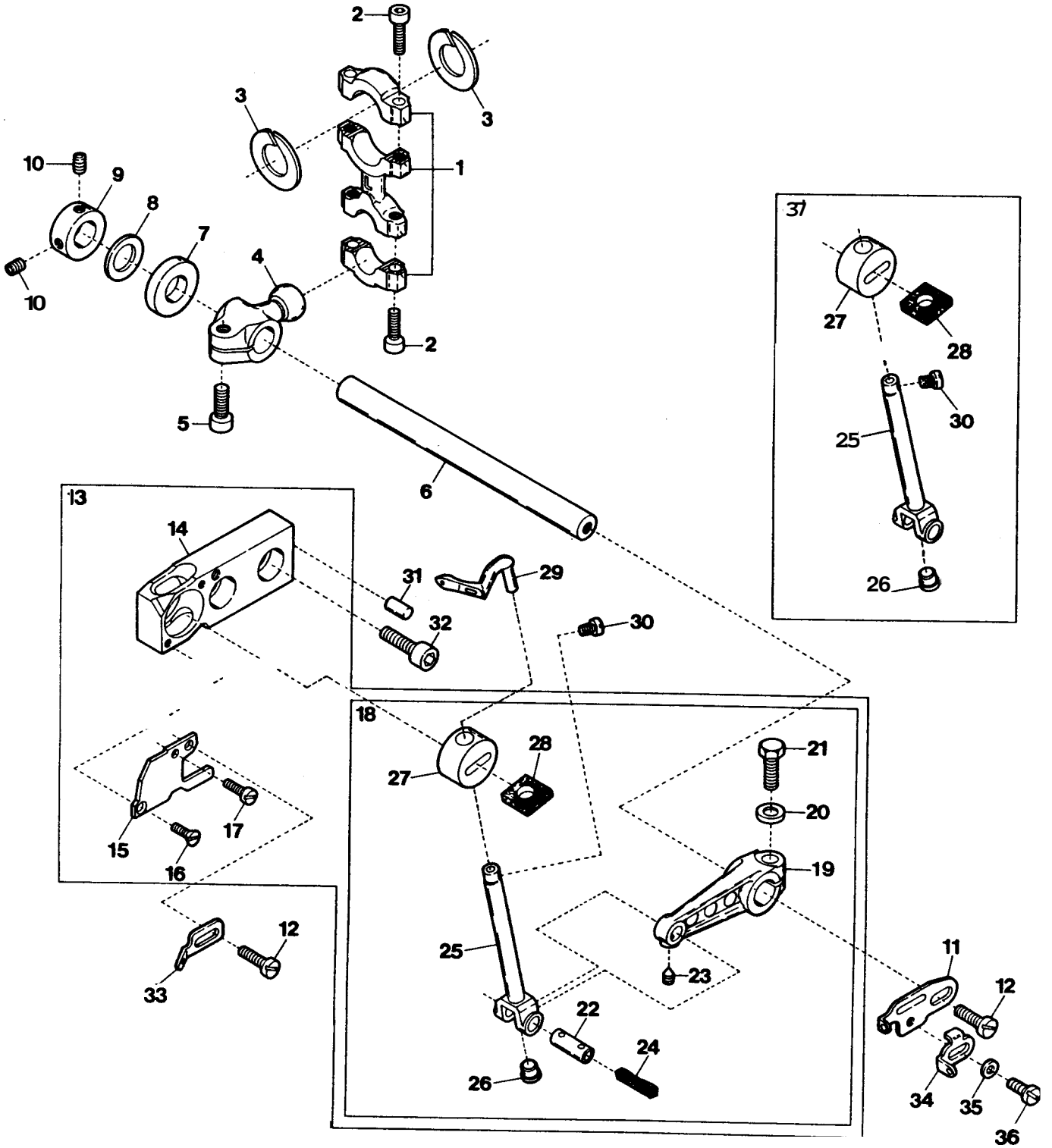

**UPPER LOOPER DRIVING MECHANISM**

**上ルーパ機構**

Ref. No.	Parts No.	Description	品名	Amt. Req.
1	2100900	Looper Driving Lever Connecting Rod	ルーパロッド	1
2	120049	Screw (M4-0.7×16)	止ネジ	4
3	2100088	Connecting Rod Swing-proof	振レ止メ	2
4	2150071	Upper Looper Driving Lever	上ルーパ軸腕	1
5	120006	Screw (M6-1×12)	止ネジ	1
6	2150070	Looper Driving Shaft	上ルーパ軸	1
7	2150072	Driving Shaft Thrust Ring	スラストリング	1
8	2150075	Driving Shaft Thrust Ring	スラストリング	1
9	2100161	Collar (10×19×9mm)	カラー	1
10	160001	Screw (M4-0.7×4)	止ネジ	2
11	2150130	Upper Looper Thread Pull-off	上ルーパ糸繰り	1
12	110009	Screw (M4-0.7×8)	止ネジ	2
13	2150515	Upper Looper Bar Crank Arm, C. Set	上ルーパクランク(組)	1
14	2150084	Upper Looper Bar Guide Bushing	ルーパ案内メタル	1
15	2100227	Upper Looper Bar Guide Cover	ルーパ案内蓋	1
16	130001	Screw (M2.5-0.45×6)	止ネジ	1
17	110071	Screw (M2.5-0.45×6)	止ネジ	1
18	2100884	Upper Looper Bar Guide, Complete Set	ルーパ案内(組)	1
19	2100221	Upper Looper Bar Crank Arm	上ルーパクランク	1
20	300008	Washer	ワッシャ	1
21	140004	Screw (M6-1×16)	止ネジ	1
22	2100903	Upper Looper Bar Crank Arm Pin	上ルーパクランクピン	1
23	160002	Screw (M4-0.7×5)	止ネジ	1
24	310089	Oil Wick	油芯	1
25	2100667	Upper Looper Bart	ルーパ棒	1
26	000629	Seal Plug	詰栓	1
27	2100892	Upper Looper Bar Guide	ルーパ案内	1
28	310065	Oiling Felt	フェルト	2
29	2109322	Upper Looper (for Needle Size #9~14)	上ルーパ(針番手#9~14用)	1
30	210009	Screw (1/8-44×3.2)	止ネジ	1
31	000779	Standard Pin	基準ピン	1
32	120013	Screw (M6-1×15)	止ネジ	2
33	2100854	Upper Looper Supplementary Thread Eyelet	上ルーパ補助糸道	1
34	2150117	Lower Looper Thread Pull-off	下ルーパ糸繰り	1
35	000014	Washer	ワッシャ	1
36	110002	Screw (M3-0.5×5)	止ネジ	1
37	2100890	Upper Looper Bar, C. Set	ルーパ棒(組)	1

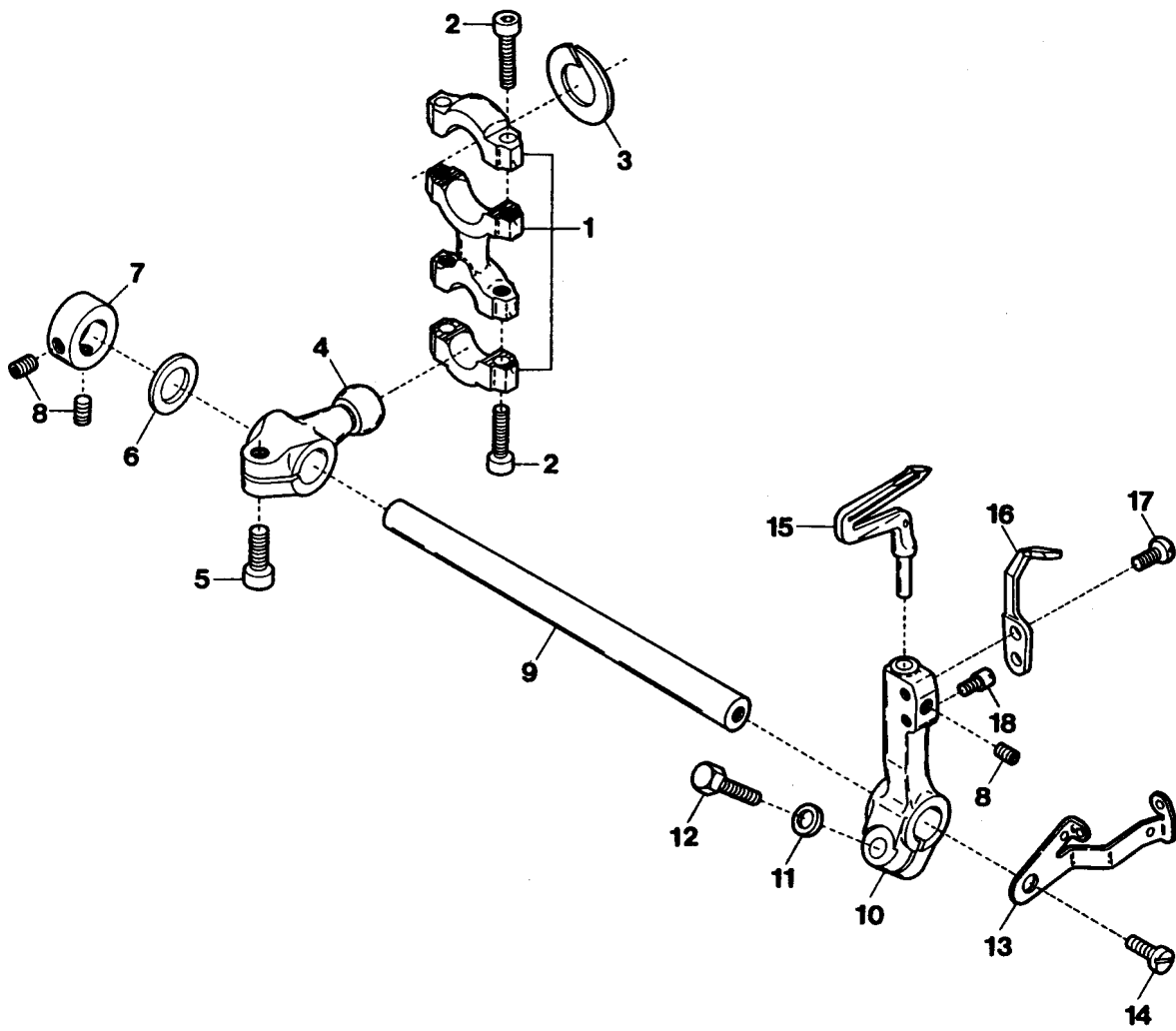

**LOWER LOOPER DRIVING MECHANISM**

**下ルーパ機構**

**10**

Ref. No.	Parts No.	Description	品名	Amt. Req.
1	2100215	Looper Driving Lever Connecting Rod	ルーパロッド	1
2	120049	Screw(M4-0.7×16)	止ネジ	4
3	2100088	Connecting Rod Swing-proof	振レ止メ	1
4	2150076	Lower Looper Driving Lever	下ルーパ軸腕	1
5	120006	Screw(M6-1×12)	止ネジ	1
6	2100902	Driving Shaft Thrust Ring	スラストプレート	1
7	2100161	Collar(10×19×9mm)	カラー	1
8	160003	Screw(M5-0.8×5)	止ネジ	3
9	2100219	Looper Driving Shaft	ルーパ軸	1
10	2100211	Lower Looper Holder Arm	下ルーパ台	1
11	300008	Washer	ワッシャ	1
12	140002	Screw(M6-1×14)	止ネジ	1
13	2150118	Thread Pull-off	下ルーパ台糸繰り	1
14	110009	Screw(M4-0.7×8)	止ネジ	1
15	2109347	Lower Looper	下ルーパ	1
16	2109201	Needle Guard(Rear)	針受ケ(後)	1
17	110036	Screw(M3-0.5×6.5)	止ネジ	1
18	180014	Screwed Pin(M3-0.5×4.5)	ピンネジ	1

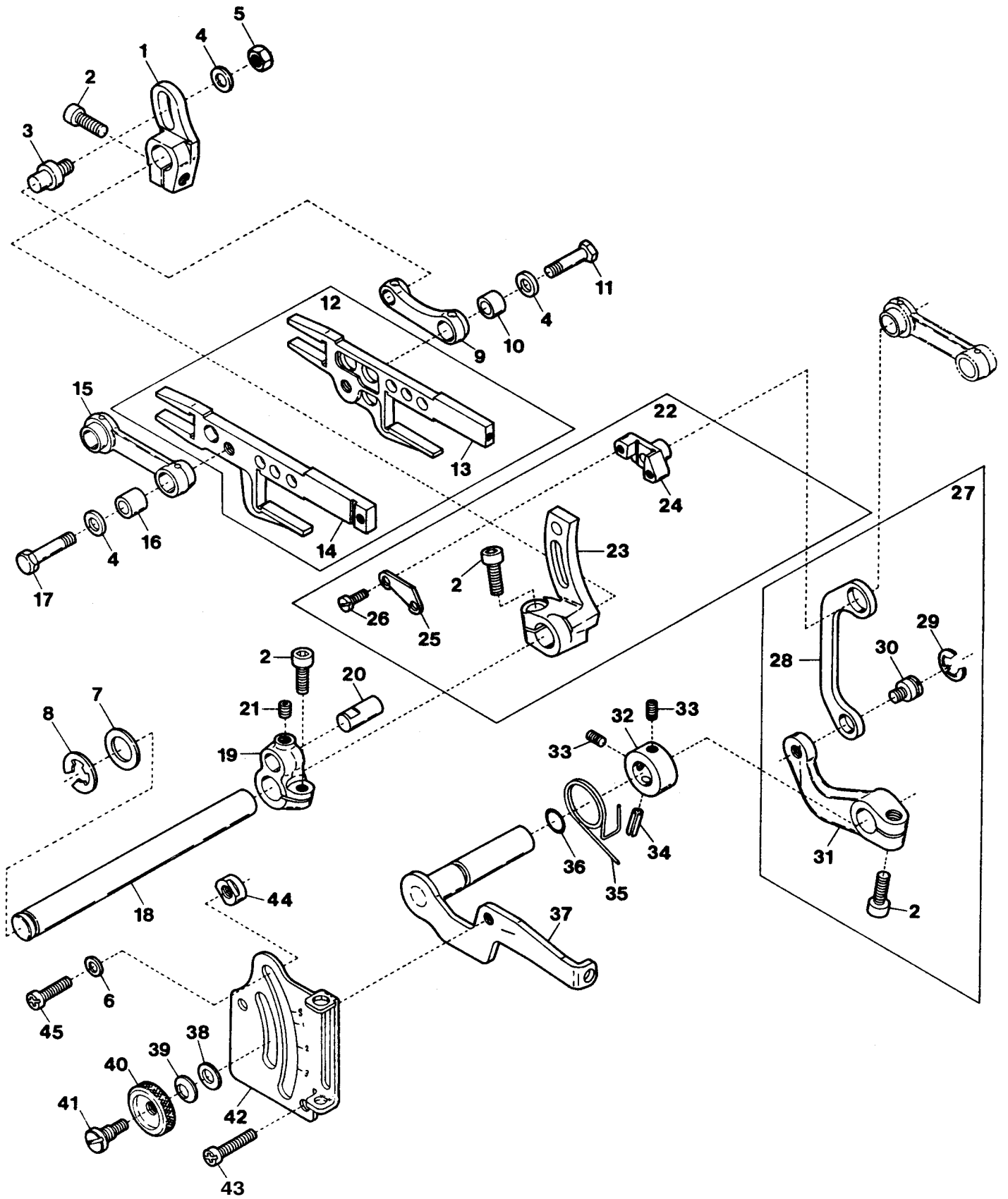



**FEED DRIVING CONTROL MECHANISM**

**前送り調節機構**

**1 1**

Ref. No.	Parts No.	Description	品名	Amt. Req.
1	2150064	Main Feed Bar Lever . . . . .	後送りレバー . . . . .	1
2	120006	Screw (M6-1×12) . . . . .	止ネジ . . . . .	4
3	2100251	Main Feed Bar Lever Pin . . . . .	後送りレバーピン . . . . .	1
4	300000	Washer . . . . .	ワッシャ . . . . .	3
5	100002	Nut . . . . .	ナット . . . . .	1
6	000669	Washer . . . . .	ワッシャ . . . . .	2
7	2150075	Thrust Plate . . . . .	スラストプレート . . . . .	1
8	0095027	Retaining Ring . . . . .	ストップリング . . . . .	1
9	2100248	Main Feed Bar Connection . . . . .	後送りリンク . . . . .	1
10	2100249	Connection Bushing . . . . .	後送りリンクブッシュ . . . . .	1
11	140001	Screw (M5-0.5×12) . . . . .	止ネジ . . . . .	1
12	2100266	Feed Bar, Complete Set . . . . .	前後送り台(組) . . . . .	1
13	2100242	Main Feed Bar . . . . .	後送り台 . . . . .	1
14	2100241	Differential Feed Bar . . . . .	前送り台 . . . . .	1
15	2100243	Differential Feed Bar Connection	前送りリンク . . . . .	1
16	2100244	Connection Bushing . . . . .	前送りリンクブッシュ . . . . .	1
17	140000	Screw (M5-0.5×15.5) . . . . .	止ネジ . . . . .	1
18	2150065	Feed Bar Driving Shaft . . . . .	送り軸 . . . . .	1
19	2150066	Feed Bar Driving Shaft Lever . . . . .	送り軸腕 . . . . .	1
20	2100288	Connecting Rod Pin . . . . .	送りロッドピン . . . . .	1
21	160007	Screw (M6-1×6) . . . . .	止ネジ . . . . .	1
22	2100671	Differential Rocker, Complete Set	前送り腕(組) . . . . .	1
23	2100672	Differential Rocker . . . . .	前送り腕 . . . . .	1
24	2100673	Differential Regulating Slider . . . . .	スライダ . . . . .	1
25	2100674	Differential Regulating Slider Cap	スライダ蓋 . . . . .	1
26	110033	Screw (M3-0.5×6) . . . . .	止ネジ . . . . .	2
27	2100269	Differential Lever (Right), C. Set	差動レバー(右)(組) . . . . .	1
28	2100252	Slider Link . . . . .	スライダリンク . . . . .	1
29	0068202	Retaining Ring . . . . .	ストップリング . . . . .	1
30	2100253	Slider Link Pin . . . . .	スライダリンクピン . . . . .	1
31	2100262	Differential Lever (Right) . . . . .	差動レバー(右) . . . . .	1
32	2100267	Collar (10×17×8mm) . . . . .	カラー . . . . .	1
33	160001	Screw (M4-0.7×4) . . . . .	止ネジ . . . . .	2
34	000690	Spring Pin . . . . .	スプリングピン . . . . .	1
35	2100256	Differential Lever Spring . . . . .	差動レバーバネ . . . . .	1
36	0020538	O-ring (P7) . . . . .	Oリング . . . . .	1
37	2100263	Differential Lever (Left) . . . . .	差動レバー(左) . . . . .	1
38	000528	Washer . . . . .	ワッシャ . . . . .	1
39	000561	Conical Spring Washer . . . . .	皿バネワッシャ . . . . .	1
40	100000	Adjusting Nut . . . . .	調節ナット . . . . .	1
41	190001	Adjusting Screw (M6-1×11.5, M4.5-0.5×4)	調節ネジ . . . . .	1
42	2100271	Differential Feed Graduation . . . . .	送り目盛板 . . . . .	1
43	110016	Screw (M4-0.7×15) . . . . .	止ネジ . . . . .	2
44	0020350	Differential Lever Stop . . . . .	差動レバーストップ . . . . .	2
45	110017	Screw (M5-0.8×8) . . . . .	止ネジ . . . . .	2

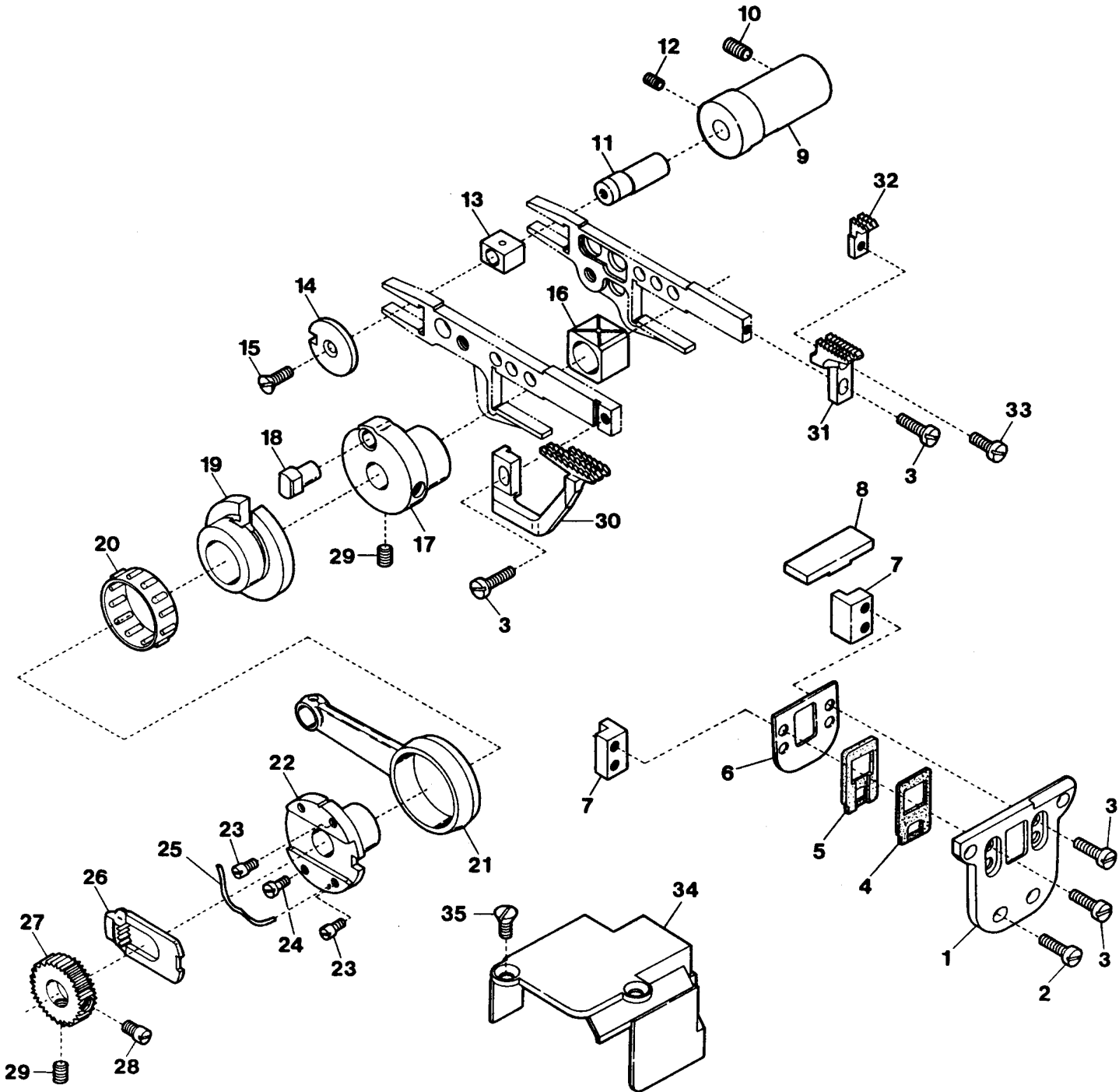

**FEED DRIVING MECHANISM**

**送り機構**

**12**

Ref.	Parts			Amt.
<u>No.</u>	<u>No.</u>	<u>Description</u>	<u>品名</u>	<u>Req.</u>
1	2100865	Feed Bar Guide Support . . . . .	送り台ガイドサポート . . . . .	1
2	110064	Screw (M4-0.7×8) . . . . .	止ネジ . . . . .	4
3	110004	Screw (M3.5-0.6×8) . . . . .	止ネジ . . . . .	5
4	2100866	Feed Bar Shield (Front) . . . . .	送り台シール(前) . . . . .	1
5	2100867	Feed Bar Shield (Rear) . . . . .	送り台シール(後) . . . . .	1
6	2100869	Feed Bar Shield Guide . . . . .	送り台シールガイド . . . . .	1
7	2100870	Feed Bar Guide . . . . .	送り台ガイド . . . . .	2
8	2100868	Feed Bar Shield (Upper) . . . . .	送り台シール(上) . . . . .	1
9	2150063	Feed Bar Guide Bushing . . . . .	送り台ガイドブッシュ . . . . .	1
10	160007	Screw (M6-1×6) . . . . .	止ネジ . . . . .	1
11	2100602	Feed Bar Block (Rear) Shaft . . . . .	角駒(後)軸 . . . . .	1
12	160001	Screw (M4-0.7×4) . . . . .	止ネジ . . . . .	1
13	2100283	Feed Bar Block (Rear) . . . . .	角駒(後) . . . . .	1
14	2100281	Feed Bar Block (Rear) Lid . . . . .	角駒(後)蓋 . . . . .	1
15	130002	Screw (M3-0.5×6) . . . . .	止ネジ . . . . .	1
16	2100280	Feed Bar Block (Front) . . . . .	角駒(前) . . . . .	1
17	2100284	Eccentric Pin Holder . . . . .	送リエキセンピン取付台 . . . . .	1
18	0020401	Feed Dog Eccentric Pin . . . . .	送リエキセンピン . . . . .	1
19	2100277	Feed Dog Eccentric . . . . .	送リエキセン . . . . .	1
20	2100278	Roller Bearing . . . . .	ニードルベアリング . . . . .	1
21	2100275	Feed Dog Driving Connecting Rod . . . . .	送りロッド . . . . .	1
22	2100276	Feed Dog Regulating Eccentric . . . . .	送り調節エキセン . . . . .	1
23	180002	Screw (M3-0.5×4) . . . . .	止ネジ . . . . .	2
24	110070	Screw (M3-0.5×6.3) . . . . .	止ネジ . . . . .	1
25	2100289	Feed Dog Regulating Plate Spring . . . . .	送り調節プレートバネ . . . . .	1
26	0023473	Feed Dog Regulating Plate . . . . .	送り調節プレート . . . . .	1
27	2100279	Feed Dog Regulating Gear . . . . .	送り調節ギア . . . . .	1
28	180003	Screw (M5-0.8×8) . . . . .	止ネジ . . . . .	1
29	160003	Screw (M5-0.8×5) . . . . .	止ネジ . . . . .	3
30	2109005	Differential Feed Dog (Y5) . . . . .	前送り . . . . .	1
31	2109006	Main Feed Dog . . . . .	後送り . . . . .	1
32	2109067	Auxiliary Feed Dog . . . . .	小送り . . . . .	1
33	110026	Screw (M3-0.5×6) . . . . .	止ネジ . . . . .	1
34	2150067	Connecting Rod Cover . . . . .	送りロッドカバー . . . . .	1
35	130003	Screw (M4-0.7×7.3) . . . . .	止ネジ . . . . .	2

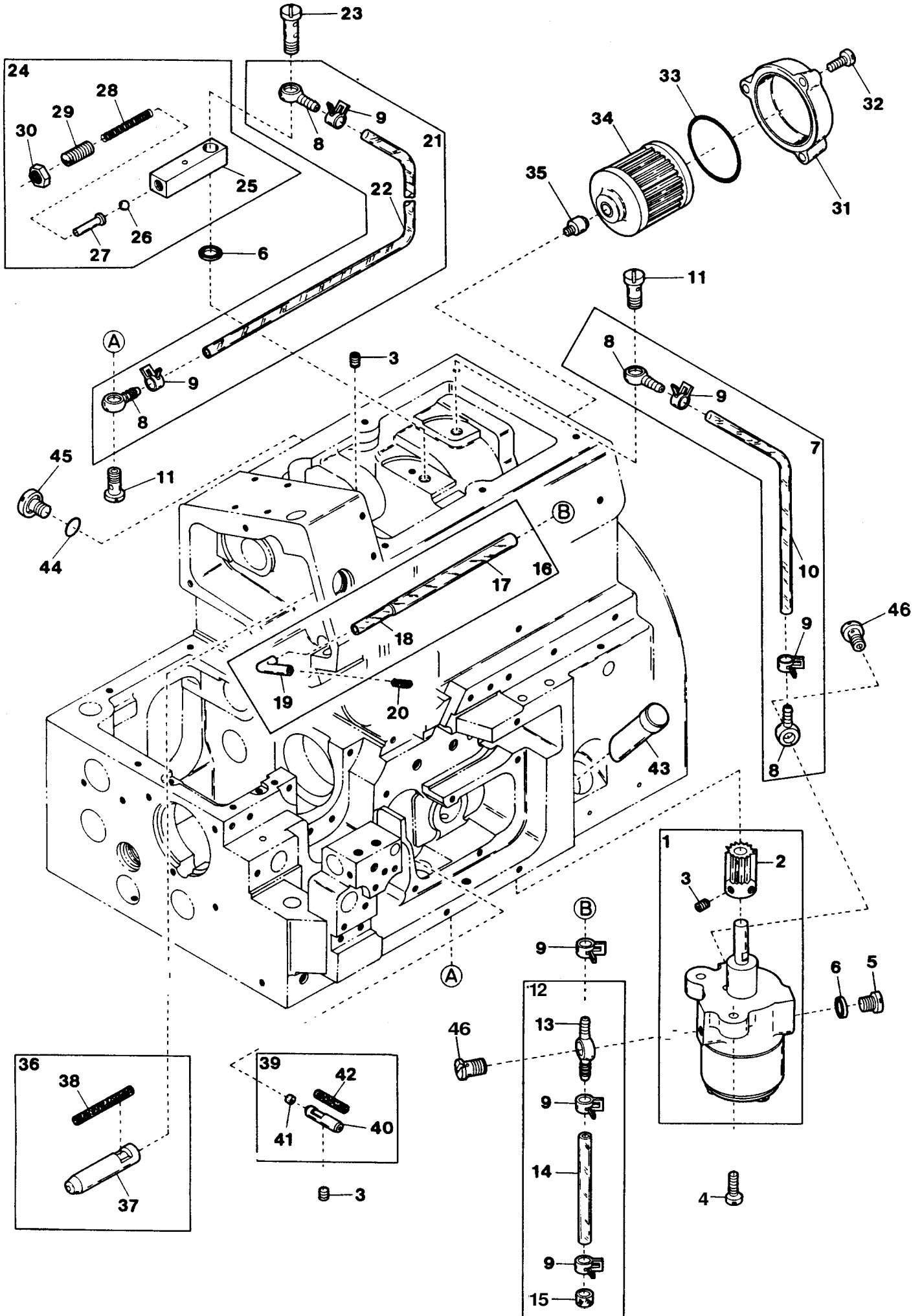

## LUBRICATING MECHANISM

## 給油機構

1 3

Ref. No.	Parts No.	Description	品名	Amt. Req.
1	2100935	Oil Pump, Complete Set . . . . .	ポンプ(組) . . . . .	1
2	2100363	Worm Wheel . . . . .	ウオームホイール . . . . .	1
3	160001	Screw(M4-0.7×4) . . . . .	止ネジ . . . . .	4
4	110016	Screw(M4-0.7×15) . . . . .	止ネジ . . . . .	2
5	001820	Screw(1/4-40×5) . . . . .	止ネジ . . . . .	1
6	000567	Seal . . . . .	パッキン . . . . .	2
7	2150201	Oil Tube, Complete Set . . . . .	給油パイプ(組) . . . . .	1
8	3100370	Oil Tube Fitting One Way End . . . . .	片口管継手 . . . . .	4
9	0031831	Oil Tube Clamp . . . . .	緊束環 . . . . .	7
10	2150206	Oil Tube(4.6×6.4×220mm) . . . . .	給油パイプ . . . . .	1
11	320008	Oil Tube Fitting Stud(M6-1) . . . . .	管継手ボルト . . . . .	2
12	2100958	Suction Tube, C. Set . . . . .	吸入パイプ(組) . . . . .	1
13	3100371	Oil Tube Fitting Two Way . . . . .	両口管継手 . . . . .	1
14	2100369	Oil Tube(4.6×6.4×36.5mm) . . . . .	給油パイプ . . . . .	1
15	2100957	Oil Filter . . . . .	濾過網 . . . . .	1
16	2100926	Suction Pipe(Upper), C. Set . . . . .	吸入パイプ(上)(組) . . . . .	1
17	2100927	Suction Tube(4×6×18mm) . . . . .	吸入パイプ . . . . .	1
18	2100928	Suction Tube(2.5×4×60mm) . . . . .	吸入パイプ . . . . .	1
19	2100929	Suction Pipe(Upper) . . . . .	吸入パイプ(上) . . . . .	1
20	310073	Felt . . . . .	フェルト . . . . .	1
21	2150202	Oil Tube, Complete Set . . . . .	給油パイプ(組) . . . . .	1
22	2150207	Oil Tube(4.6×6.4×320mm) . . . . .	給油パイプ . . . . .	1
23	320009	Oil Tube Fitting Stud(Long)(M6-1) . . . . .	管継手ボルト(長) . . . . .	1
24	2150095	Oil Pressure Regulating Valve, C. Set . . . . .	調圧弁(組) . . . . .	1
25	2150094	Oil Pressure Regulating Valve . . . . .	調圧弁 . . . . .	1
26	0080503	Oil Pressure Regulating Ball . . . . .	調圧ボール弁 . . . . .	1
27	0030748	Guide Pin . . . . .	ガイドピン . . . . .	1
28	2150097	Spring . . . . .	バネ . . . . .	1
29	006861	Adjusting Screw(1/4-40×5) . . . . .	調節ネジ . . . . .	1
30	000419	Nut . . . . .	ナット . . . . .	1
31	3100060	Oil Filter Cap . . . . .	オイルフィルタキャップ . . . . .	1
32	110045	Screw(M4-0.7×12) . . . . .	止ネジ . . . . .	3
33	3100061	O-ring(P42) . . . . .	Oリング . . . . .	1
34	3100345	Oil Filter . . . . .	オイルフィルタ . . . . .	1
35	3100329	Filter Housing . . . . .	オイルフィルタ継手 . . . . .	1
36	2150055	Oil Pipe, C. Set . . . . .	オイルパイプ(組) . . . . .	1
37	2150056	Oil Pipe . . . . .	オイルパイプ . . . . .	1
38	310081	Oil Wick . . . . .	油芯 . . . . .	1
39	2100896	Oil Pipe, C. Set . . . . .	オイルパイプ(組) . . . . .	1
40	2100895	Oil Pipe . . . . .	オイルパイプ . . . . .	1
41	000456	Seal Plug . . . . .	詰栓 . . . . .	1
42	310090	Oil Wick . . . . .	油芯 . . . . .	1
43	2100032	Oil Sight Gauge . . . . .	オイルゲージ . . . . .	1
44	0020538	O-ring(P7) . . . . .	Oリング . . . . .	1
45	110053	Screw(M6-1×8) . . . . .	止ネジ . . . . .	3
46	320010	Oil Tube Fitting Stud(1/4-40) . . . . .	管継手ボルト . . . . .	2

UPPER KNIFE (Angled Type)

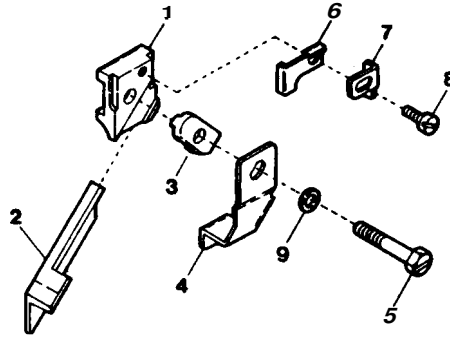

AZ6003G

10

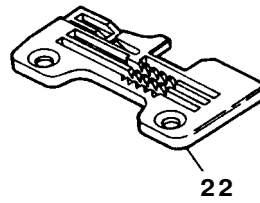
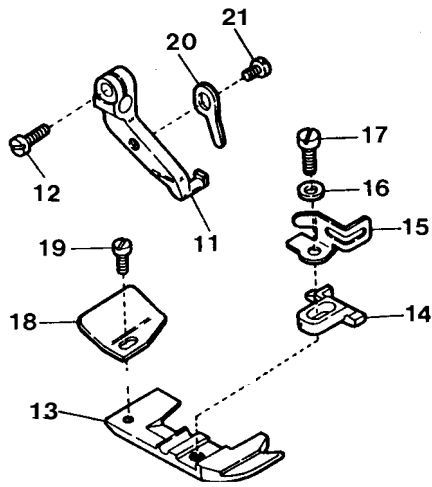

EXCLUSIVE PARTS for UPPER KNIFE (Angled Type), AZ6003G 角メス及びサテリ用部品

14

Ref. No.	Parts No.	Description	品名	Amt. Req.
1	2100385	Upper Knife Holder	上メスホルダ(角)	1
2	0020491	Upper Knife	上メス	1
3	2101435	Upper Knife Clamp	上メス押エ	1
4	2100354	Upper Knife Chip Guard	切屑押シ	1
5	140012	Screw(M4-0.7×18.5)	止ネジ	1
6	2100349	Upper Knife Clamp Plate	上メス押エ受ケ	1
7	2100353	Upper Knife Stop	上メスストッパ	1
8	110038	Screw(M2.5-0.45x4.5)	止ネジ	1
9	000665	Washer	ワッシャ	1
10	2157050	Presser Foot, C. Set(04)	押エ(組)	1
11	2157000	Presser Foot Hinge	押エヒンジ	1
12	110004	Screw(M3.5-0.6×8)	止ネジ	1
13	2157020	Presser Foot(Lower)	押エ(下)	1
14	2157200	Presser Foot Stitch Tongue(04)	爪	1
15	2107643	Finger Guard	フィンガガード	1
16	000444	Washer	ワッシャ	1
17	005036	Screw(1/8-44×5.6)	止ネジ	1
18	0034535	Thread Chain Guide	空環ガイド	1
19	004237	Screw(3/32-56×2.6)	止ネジ	1
20	2157040	Presser Foot Half-stay	半固定片	1
21	110050	Screw(M3.5-0.6×4.5)	止ネジ	1
22	2108003	Stitch Plate(04)	針板	1
23	2109320	Upper Looper	上ルーパ	1
24	0060297	Pin	ピン	1

AZ6016G

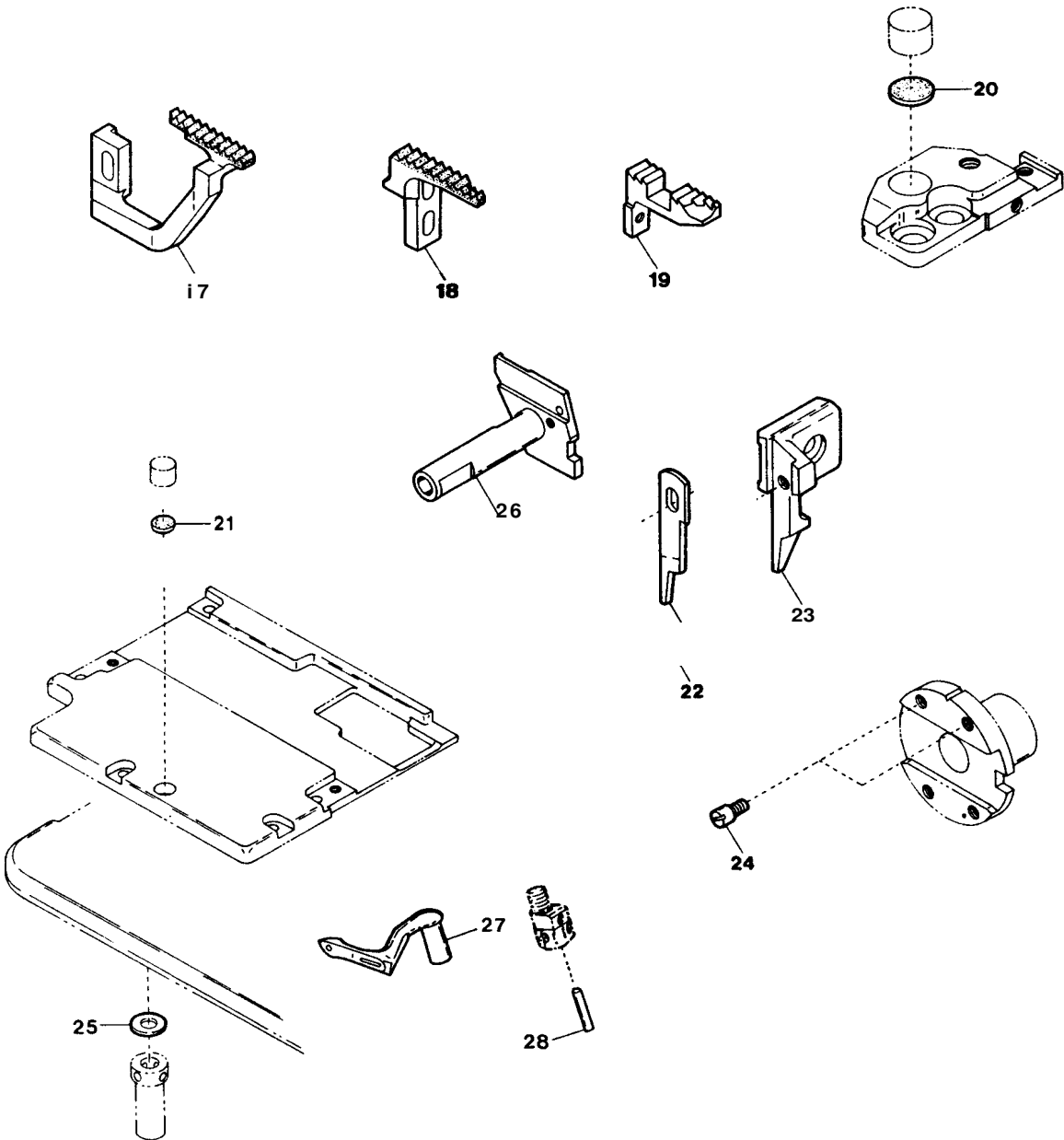
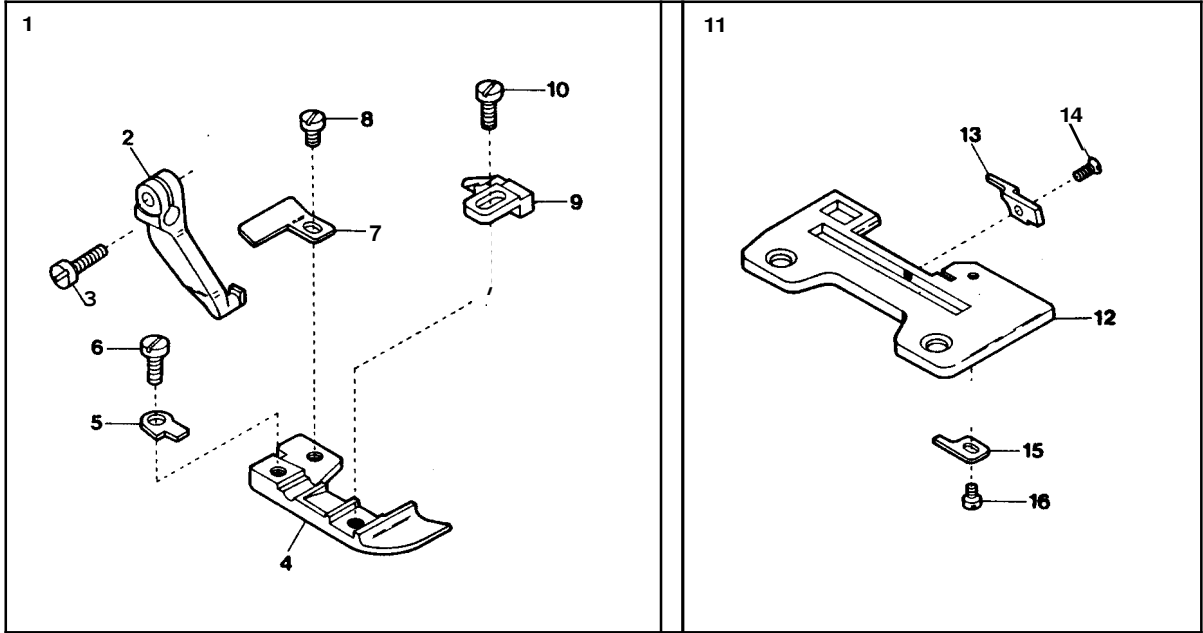



**AZ6016G EXCLUSIVE PARTS**

**サブモデル専用部品**

**15**

Ref. No.	Parts No.	Description	品名	Amt. Req.
1	2157185	Presser Foot, Complete Set (02)	押エ(組)	1
2	2157002	Presser Foot Hinge	押エヒンジ	1
3	110004	Screw(M3.5-0.6×8)	止ネジ	1
4	0024505	Presser Foot(Lower)	押エ(下)	1
5	0024421	Presser Foot Hinge Spring	押エヒンジバネ	1
6	004131	Screw(1/8-44×6)	止ネジ	1
7	0022156	Thread Chain Guide	空環ガイド	1
8	004237	Screw(3/32-56×2.6)	止ネジ	1
9	0024506	Presser Foot Stitch Tongue	爪	1
10	004138	Screw(1/8-44×5)	止ネジ	1
11	2108016	Stitch Plate, Complete Set	針板(組)	1
12	2108017	Stitch Plate	針板	1
13	2108015	Stitch Plate Tongue	針板爪	1
14	004204	Screw(3/32-100×2.2)	止ネジ	1
15	0024503	Stitch Plate Tongue Stop	針板爪ストッパ	1
16	001228	Screw(3/32-56×3.2)	止ネジ	1
17	2109017	Differential Feed Dog (with Rubber Face)	前送り(ゴム送り)	1
18	2109018	Main Feed Dog (with Rubber Face)	後送り(ゴム送り)	1
19	2109019	Auxiliary Feed Dog	小送り	1
20	000932	Rubber Cushion(Large)	埋メ座(大)	1
21	000933	Rubber Cushion(Medium)	埋メ座(中)	1
22	0023580	Upper Knife	上メス	1
23	2100346	Upper Knife Holder	上メスホルダ	1
24	180002	Screw(M3-0.5×4)	止ネジ	2
25	300040	Washer	ワッシャ	1
26	2100177	Lower Knife Holder	下メス台	1
27	2109320	Upper Looper	上ルーパ	1
28	0060297	Pin	ピン	1

"K2" DEVICE(1)

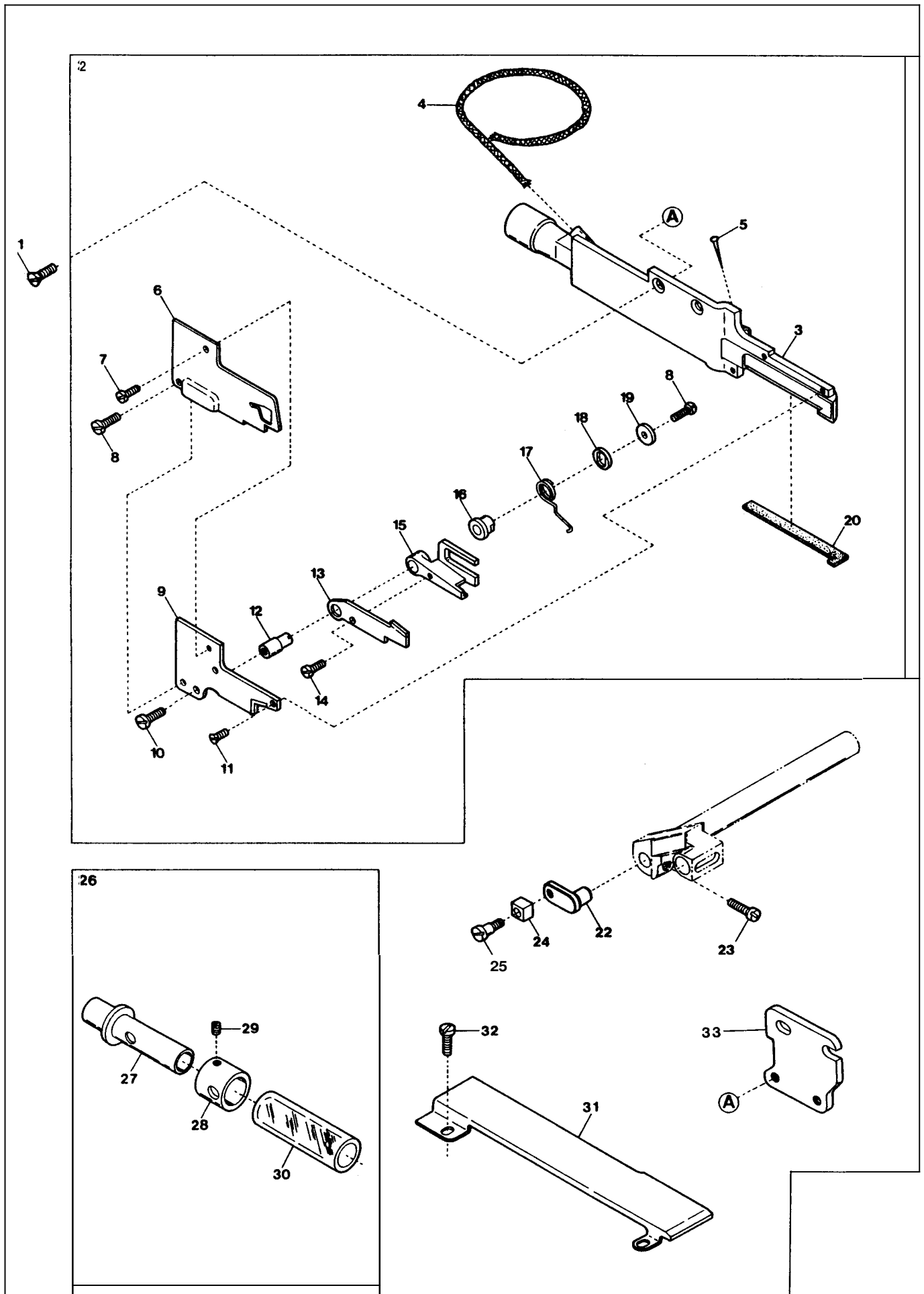

“K2” DEVICE (1)

“K2”装置(1)

16

Ref.	Parts	Description	品名	Amt. Req.
No.	No.			Req.
1	2159901	“K2” Device, Complete Set . . . . .	“K2”装置(組) . . . . .	1
2	2111050	Suction Pipe, Complete Set . . . . .	吸込管(組) . . . . .	1
3	2111051	Suction Pipe . . . . .	吸込管本体 . . . . .	1
4	310017	Oil Wick . . . . .	油芯 . . . . .	1
5	000755	Oil Wick Pin . . . . .	止メピン . . . . .	1
6	2111063	Suction Pipe Cover . . . . .	吸込管カバー . . . . .	1
7	004237	Screw(3/32-56×1.7) . . . . .	止ネジ . . . . .	1
8	004404	Screw(3/32-56×5.1) . . . . .	止ネジ . . . . .	2
9	2111055	Upper Trimming Knife . . . . .	上刃 . . . . .	1
10	004131	Screw(1/8-44×6) . . . . .	止ネジ . . . . .	1
11	004139	Screw(3/32-56×3) . . . . .	止ネジ . . . . .	2
12	2111059	Lower Trimming Knife Holder Pin . . . . .	下刃支持ピン . . . . .	1
13	2111056	Lower Trimming Knife . . . . .	下刃 . . . . .	1
14	004236	Screw(3/32-56×4.2) . . . . .	止ネジ . . . . .	1
15	2111057	Lower Trimming Knife Driving Plate . . . . .	下刃駆動板 . . . . .	1
16	2111062	Spring Sleeve . . . . .	下刃バネスリーブ . . . . .	1
17	2111061	Lower Trimming Knife Pushing Spring . . . . .	下刃圧着バネ . . . . .	1
18	2111066	Spring Protect Washer . . . . .	下刃バネワッシャ . . . . .	1
19	2111060	Washer . . . . .	ワッシャ . . . . .	1
20	2111067	Air Shield Rubber . . . . .	隙間防止ゴム . . . . .	1
21	007623	Screw(9/64-40×5.3) . . . . .	止ネジ . . . . .	2
22	2111058	Lower Trimming Knife Guide Support . . . . .	下刃ガイド取付台 . . . . .	1
23	110068	Screw(M4-0.7×8) . . . . .	止ネジ . . . . .	1
24	2101011	Lower Trimming Knife Guide . . . . .	下刃ガイド . . . . .	1
25	270001	Screw(1/8-44×3) . . . . .	止ネジ . . . . .	1
26	0021451	Suction Power Control Tube, C. Set . . . . .	吸引力調整管(組) . . . . .	1
27	0021457	Suction Power Control Tube(Inner) . . . . .	吸引力調整台 . . . . .	1
28	0021456	Suction Power Control Tube . . . . .	吸引力調整管 . . . . .	1
29	001892	Screw(1/8-44×2.9) . . . . .	止ネジ . . . . .	1
30	0021450	Nylon Hose . . . . .	吸引チューブ . . . . .	1
31	2101059	Cloth Plate Spacer . . . . .	クロスプレートスペーサ . . . . .	1
32	110042	Screw(M3.5-0.6×4) . . . . .	止ネジ . . . . .	2
33	2151000	Suction Pipe Support . . . . .	吸込管取付台 . . . . .	1

"K2" DEVICE (2)

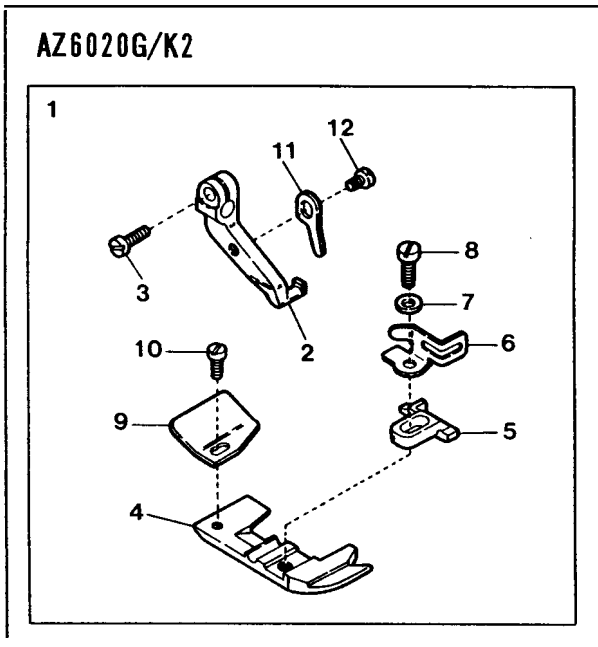

**“K2” DEVICE (2)**

**“K2”装置(2)**

**17**

Ref. No.	Parts No.	Description	品名	Amt. Req.
1	2157102	Presser Foot, C. Set (Y5)	押エ(組)	1
2	2157000	Presser Foot Hinge	押エヒンジ	1
3	110004	Screw (M3.5-0.6×8)	止ネジ	1
4	2157020	Presser Foot (Lower)	押エ(下)	1
5	2157205	Presser Foot Stitch Tongue (Y5)	爪	1
6	2107643	Finger Guard	フィンガガード	1
7	000444	Washer	ワッシャ	1
8	005036	Screw (1/8-44×5.6)	止ネジ	1
9	2107219	Thread Chain Guide	空環ガイド	1
10	004237	Screw (3/32-56×2.6)	止ネジ	1
11	2157040	Presser Foot Half-stay	半固定片	1
12	110050	Screw (M3.5-0.6×4.5)	止ネジ	1

18 "C" DEVICE

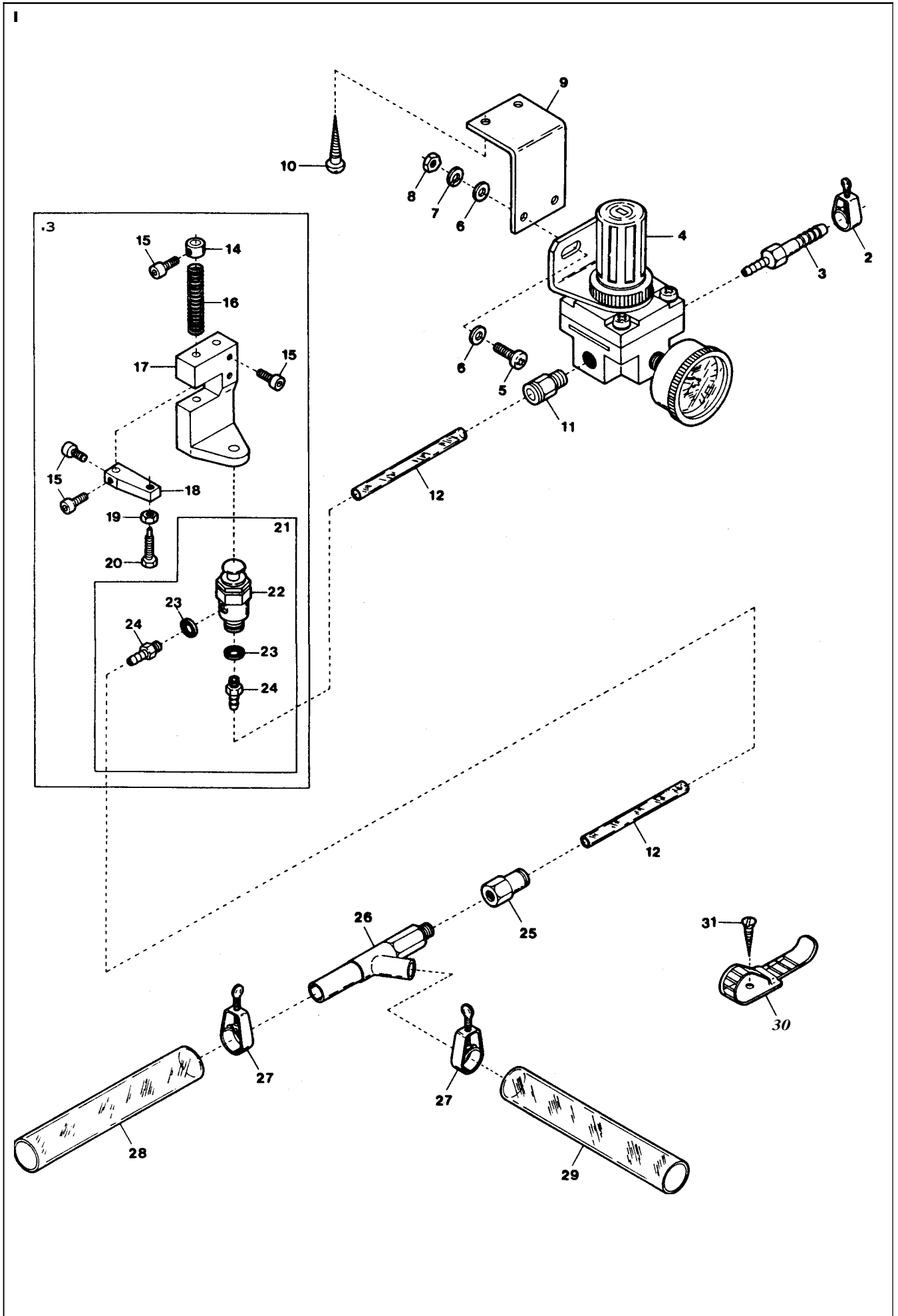

'C" DEVICE

"C"装置

18

Ref.	Parts	Description	名	Amt.
<u>No.</u>	<u>Na</u>			<u>Req.</u>
1	2109932	"C" Device, Complete Set . . . . .	"C"装置(組) . . . . .	1
2	0033939	Hose Band(1/4 inch) . . . . .	ホースバンド(1/4インチ) . . . . .	1
3	1094011	Hose Nipple(PT1/8×8) . . . . .	ホースニップル . . . . .	1
4	1097000	Regulator (AR2000-01BG) . . . . .	レギュレータ . . . . .	1
5	009960	Screw(M5-0.8×16) . . . . .	止ネジ . . . . .	2
6	000669	Washer . . . . .	ワッシャ . . . . .	4
7	000600	Spring Washer . . . . .	スプリングワッシャ . . . . .	2
8	000009	Nut . . . . .	ナット . . . . .	2
9	1097001	Regulator Support . . . . .	レギュレータ取付板 . . . . .	1
10	006905	Wood Screw(φ5.1×20) . . . . .	木ネジ . . . . .	2
11	0010263	Connector (EC6-PT1/8) . . . . .	コネクタ . . . . .	1
12	1096000	Nylon Hose(4×6×2000mm) . . . . .	ナイロンホース . . . . .	1
13	1298000	Air Valve, Complete Set . . . . .	エアバルブ(組) . . . . .	1
14	0033938	Collar(6.4×13×9mm) . . . . .	エアバルブ補助バネカラー . . . . .	1
15	005040	Screw(11/64-40×8.5) . . . . .	止ネジ . . . . .	5
16	0033937	Return Spring . . . . .	エアバルブ補助バネ . . . . .	1
17	0033936	Air Valve Holder . . . . .	エアバルブ取付台 . . . . .	1
18	0033935	Air Valve Stop . . . . .	エアバルブストッパ . . . . .	1
19	000334	Nut . . . . .	ナット . . . . .	1
20	005505	Adjusting Screw(11/64-40×16) . . . . .	調節ネジ . . . . .	1
21	1090133	TAC Valve, C. Set . . . . .	TACバルブ(組) . . . . .	1
22	0010052	TAC Valve . . . . .	TACバルブ . . . . .	1
23	000623	Gasket . . . . .	パッキン . . . . .	2
24	0010112	Joint (I-4) . . . . .	継手 . . . . .	2
25	0010290	Connector (EFC6-PT1/8) . . . . .	継手 . . . . .	1
26	0010310	Venturi Tube . . . . .	ベンチュリ管 . . . . .	1
27	0033940	Hose Band(3/8 inch) . . . . .	ホースバンド(3/8インチ) . . . . .	2
28	1096004	Vinyl Hose(12×18×1500mm) . . . . .	ビニールホース . . . . .	1
29	1096005	Vinyl Hose(12×18×500mm) . . . . .	ビニールホース . . . . .	1
30	0011987	UL Clamp . . . . .	ULクランプ . . . . .	3
31	009814	Wood Screw(φ3.1×20) . . . . .	木ネジ . . . . .	3

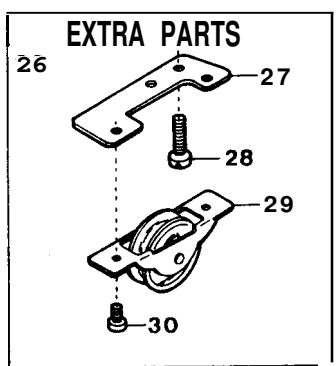
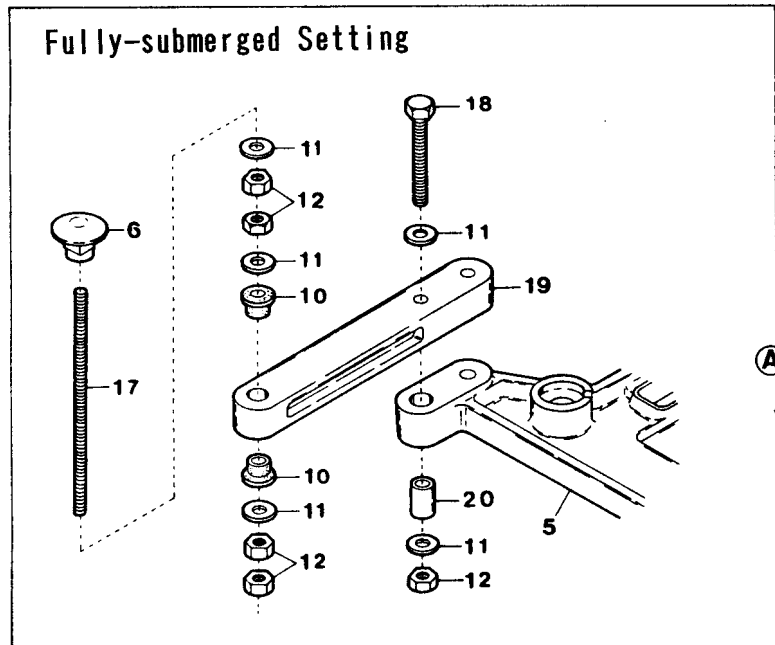
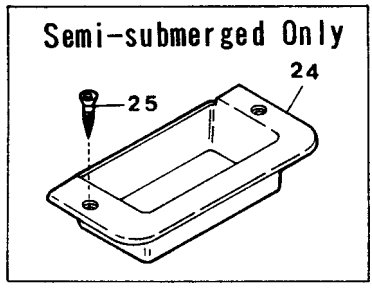
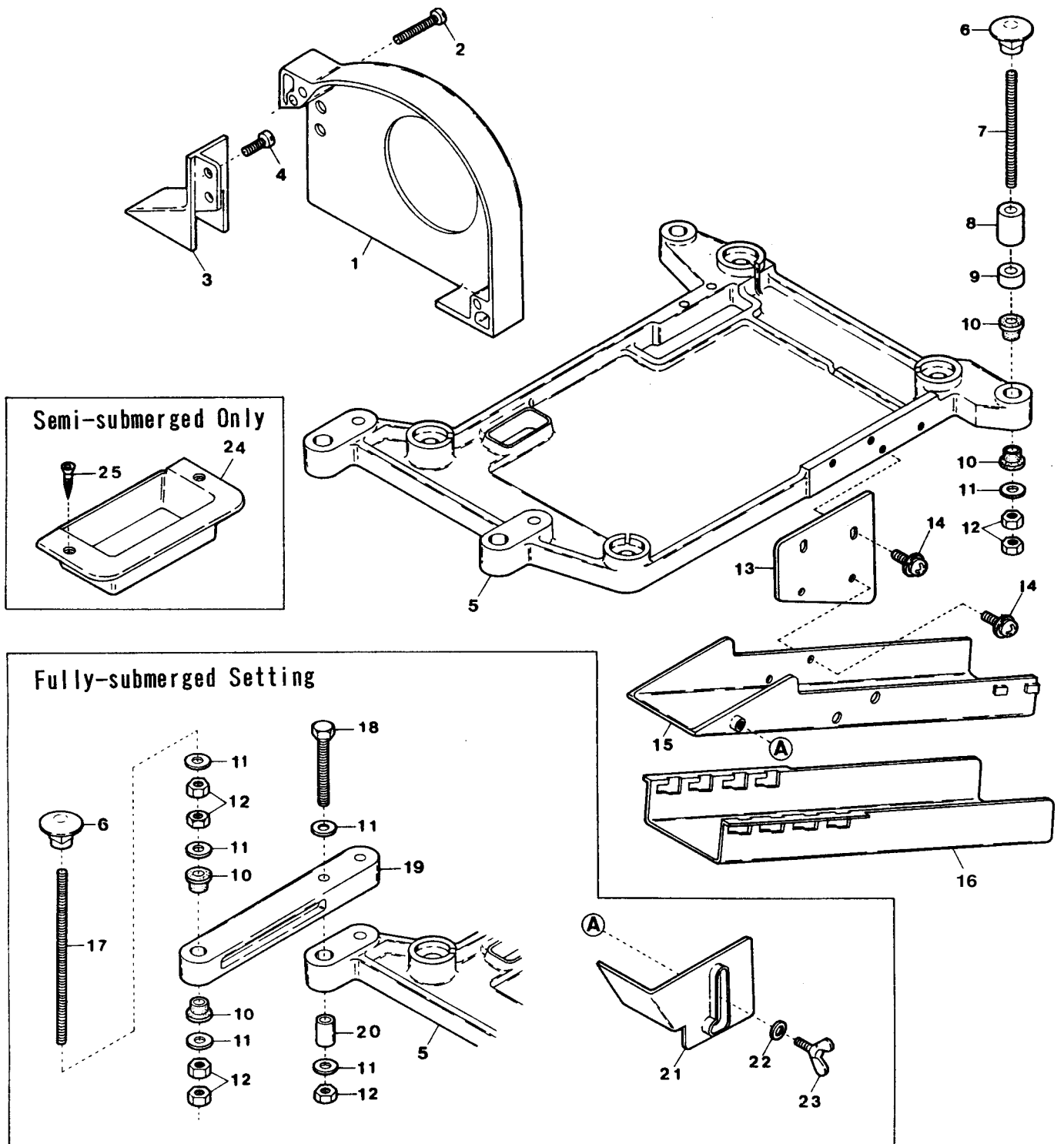



**MISCELLANEOUS SUPPORTING BOARD**

**受ケ板関係**

**19**

Ref. No.	Parts No.	Description	品名	Amt. Req.
1	2150212	Belt Cover	ベルトカバー	1
2	110015	Screw(M4-0.7×25)	止ネジ	2
3	2150213	Supplementary Belt Cover	ベルト補助カバー	1
4	110013	Screw(M4-0.7×8)	止ネジ	2
5	2100339	Supporting Board	受ケ板	1
6	000070	Hanging Nut	吊リナット	4
7	009861	Hanging Bolt (Semi-submerged only)	吊リボルト(半沈式のみ)	4
8	2101450	Spacer(15mm)	受ケ板スペーサ	4
9	2101451	Spacer(5mm) (See the below)	受ケ板スペーサ(下記参照)	4
10	0020064	Supporting Board Rubber Cushion	受ケ板ゴム座	8
11	000162	Washer(Semi-submerged)	ワッシャ(半沈式)	4
11	000162	" (Full-submerged)	ワッシャ(全沈式)	20
12	000016	Nut (Semi-submerged)	ナット(半沈式)	8
12	000016	Nut (Full-submerged)	ナット(全沈式)	20
13	2100375	Chute(Upper) Support	シュート(上)取付板	1
14	005624	Screw(M4-0.7×10)	止ネジ	4
15	2100337	Chute(Upper)	シュート(上)	1
16	2100338	Chute(Lower)	シュート(下)	1
17	009864	Hanging Bolt (Full-submerged only)	吊リボルト(全沈式のみ)	4
18	009871	Bolt (Full-submerged only)	ボルト(全沈式のみ)	4
19	0020057	Supporting Board Connector(Full-submerged only)	受ケ板支具(全沈式のみ)	2
20	0020045	Supporting Board Sleeve (Full-submerged only)	受ケ板スリーブ(全沈式のみ)	2
21	2100336	Supplementary Chute Cover	シュート補助カバー	1
22	000538	Washer	ワッシャ	1
23	140011	Wing Bolt(M4-0.7×6)	チョウボルト	1
24	2100374	Chip Receiver(Semi-submerged only)	切屑受ケ(半沈式のみ)	1
25	350007	Wood Screw(φ3.5×16)	木ネジ	2
26	0020078	Idler, C. Set(for Left Footing Pedal)	アイドラ(組)	1
27	0020077	Idler Support	アイドラ取付板	1
28	009992	Screw(M4-0.7×10)	止ネジ	2
29	0020076	Idler	アイドラ	1
30	009995	Screw(M3-0.5×5)	止ネジ	2

(注) テーブルの厚さ45mmの時は不要。

Note: Not necessary when the thickness of Table is 45mm.

-1

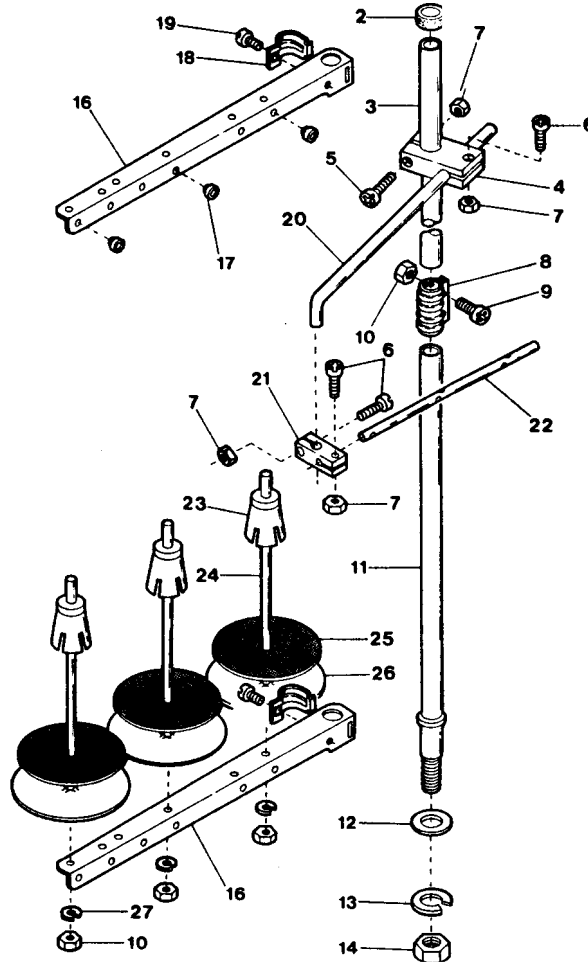

1-2

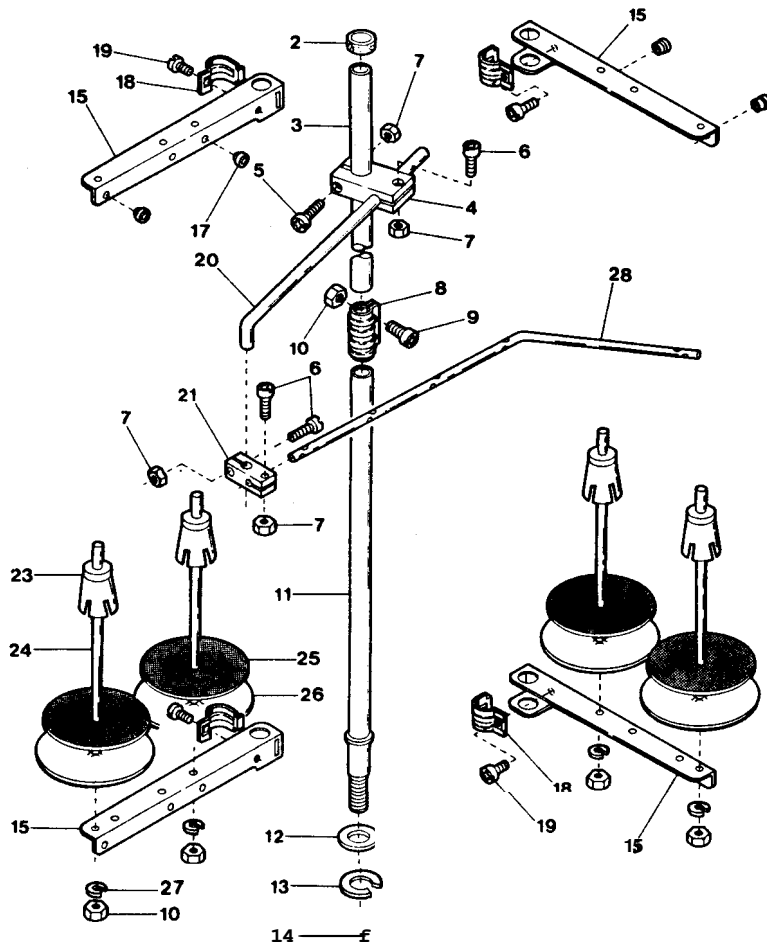

**THREAD STAND**

**糸立台**

**20**

Ref. No.	Parts No.	Description	品名	Amt. Req.
1-1	9620693	Thread Stand, C. Set (3 Spools Type)	糸立台(組) (3本糸用)	1
1-2	9620694	" " (4 Spools Type)	" " (4本糸用)	1
2	9620631	Column Cap	コラムキャップ	1
3	9620670	Column Pipe (Upper)	コラムパイプ(上)	1
4	9620689	Thread Guide Holder (Large)	ガイドホルダ(大)	1
5	911002	Screw (M4-0.7×20)	止ネジ	1
6	911001	Screw (M4-0.7×12)	止ネジ	3
7	910001	Nut	ナット	4
8	9620673	Column Pipe Connector	コラムパイプ継手	1
9	911006	Screw (M5-0.8×13)	止ネジ	2
10	910000	Nut	ナット	5(6)
11	9620675	Column Pipe (Lower)	コラムパイプ(下)	1
12	930052	Washer	ワッシャ	1
13	930053	Spring Washer	スプリングワッシャ	1
14	910003	Nut (M16-1.5)	ナット	1
15	9620702	Thread Hanger (2 Spools Type)	スレッドハンガ(2本糸用)	4
16	9620703	Thread Hanger (3 Spools Type)	スレッドハンガ(3本糸用)	2
17	9620700	Thread Eyelet	アイレット	3(4)
18	9620688	Thread Hanger Holder	スレッドハンガ抱キ	2(4)
19	911060	Screw (M6-1×15)	止ネジ	2(4)
20	9620691	Thread Guide Arm	ガイドアーム	1
21	9620690	Thread Guide Holder (Small)	ガイドホルダ(小)	1
22	9620663	Thread Guide (3 Spools Type)	スレッドガイド(3本糸用)	1
23	9620678	Spool Cushion	スプールクッション	3(4)
24	9620679	Spool Pin	スプール軸	3(4)
25	9620680	Spool Mat	スプールマット	3(4)
26	9620681	Spool Seat Disc	受ケ皿	3(4)
27	930055	Spring Washer	スプリングワッシャ	3(4)
28	9620665	Thread Guide (5 Spools Type)	スレッドガイド(5本糸用)	1

L A B E L ラベル	Parts No. 部品番	Description 品名
 <p><b>CAUTION</b></p> <p>Do not operate without eye guard and safety devices. Before threading, changing needle, cleaning etc. switch off main switch.</p>	390140	CAUTION IN OPERATION
 <p><b>注意</b></p> <p>動く部分でけがをする。 安全保護装置をつけて縫製作業をすること。 電源を切ってから、糸通し、ポビンや針の交換、掃除や調整をすること。</p>	390143	操作注意ラベル
 <p><b>高電圧警告</b> <b>DANGER</b></p> <p>このカバーを開けるときは、電源スイッチを切った後、5分たってから開けること。</p> <p>To open this cover, turn off power supply and wait more than 5 minutes before opening.</p>	390144	DANGER : WARNING OF ELECTRIC SHOCK BY HIGH-VOLTAGE 感電注意ラベル
	390145	"Be sure to connect earth line." アースラベル
	390146	ROTATING-DIRECTION SYMBOL : CHECK CORRECT ROTATING DIRECTION 回転方向表示ラベル
 <p>ケガ注意 <b>CAUTION</b></p>	390147	EYE GUARD : TAKE CARE NOT CAUSE INJURY TO EYES BELT COVER : DO NOT INSERT FINGERS ケガ注意ラベル
 <p>高温注意 <b>CAUTION</b></p>	390148	CAUTION FOR HIGH TEMPERATURE : DO NOT TOUCH STEPPING MOTOR AND SOLENOID 高温注意ラベル

# LIST of MAIN SPARE PARTS

(主要部品リスト)





AZ600OG

INDEX

Parts No.	Page No.	Ref. No.	Weight (g)	Parts No.	Page No.	Ref. No.	Weight (g)	Parts No.	Page No.	Ref. No.	Weight (g)
000009	18	8		004131	15	6		0020137	1	29	
000010	2	6		004131	16	10		0020350	11	44	
000014	4	44		004138	15	10		0020401	12	18	
000014	9	35		004139	16	11		0020491	14	2	
000016	19	12		004204	15	14		0020496	7	13	
000035	6	26		004236	16	14		0020538	11	36	
000070	19	6		004237	8	39		0020538	13	44	
000162	19	11		004237	14	19					
000177	4	9		004237	15	8		0021450	16	30	
000178	4	7		004237	16	7		0021451	16	26	
000322	4	26		004237	17	10		0021456	16	28	
000334	18	19		004404	16	8		0021457	16	27	
000393	6	45									
000419	13	30		005036	8	43		0022156	15	7	
000444	2	9		005036	14	17		0022215	4	46	
000444	8	42		005036	17	8					
000444	14	16		005040	18	15		0023473	12	26	
000444	17	7		005075	1	30		0023580	15	22	
000456	13	41		005345	6	31					
000482	8	6		005505	18	20		0024083	4	4	
000526	5	23		005624	19	14		0024084	4	3	
000528	11	38						0024095	2	25	
000532	7	14		006035	4	24		0024156	4	14	
000538	19	22		006816	1	22		0024157	4	5	
000561	11	39		006861	13	29		0024421	15	5	
000567	6	48		006905	18	10		0024446	2	20	
000567	13	6						0024503	15	15	
000600	18	7		007623	16	21		0024505	15	4	
000623	18	23						0024506	15	9	
000629	9	26		009814	18	31					
000644	1	5		009861	19	7		0030748	13	27	
000644	4	25		009864	19	17					
000653	4	30		009871	19	18		0031111	4	8	
000665	14	9		009960	18	5		0031831	13	9	
000669	11	6		009992	19	28					
000669	18	6		009995	19	30		0032604	6	34	
000688	7	27						0032879	1	23	
000690	11	34		0010052	18	22		0032919	7	24	
000726	1	37		0010112	18	24		0032952	4	12	
000755	16	5		0010263	18	11		0032962	4	11	
000779	9	31		0010290	18	25		0032971	4	13	
000932	15	20		0010310	18	26					
000933	15	21						0033024	3	14	
				0011987	18	30		0033627	1	24	
001123	1	4						0033935	18	18	
001203	2	21		0020004	1	15		0033936	18	17	
001228	15	16		0020005	1	16		0033937	18	16	
001820	13	5		0020016	2	22		0033938	18	14	
001892	16	29		0020045	19	20		0033939	18	2	
				0020057	19	19		0033940	18	27	
003636	5	22		0020064	19	10					
003637	1	10		0020076	19	29		0034535	8	38	
003637	2	23		0020077	19	27		0034535	14	18	
003637	6	23		0020078	19	26					
				0020118	4	6		0036518	3	22	



**INDEX**

<u>Parts</u> <u>No.</u>	<u>Page</u> <u>No.</u>	<u>Ref.</u> <u>No.</u>	<u>Weight</u> <u>(g)</u>	<u>Parts</u> <u>No.</u>	<u>Page</u> <u>No.</u>	<u>Ref.</u> <u>No.</u>	<u>Weight</u> <u>(g)</u>	<u>Parts</u> <u>No.</u>	<u>Page</u> <u>No.</u>	<u>Ref.</u> <u>No.</u>	<u>Weight</u> <u>(g)</u>
0060297	14	24		110026	12	33		150004	3	10	
0060297	15	28		110031	1	14		160001	1	8	
0068202	11	29		110033	11	26		160001	5	4	
0068517	3	15		110035	4	40		160001	8	31	
0080503	13	26		110035	7	12		160001	9	10	
0093090	5	7		110036	10	17		160001	11	33	
0093303	4	37		110038	14	8		160001	12	12	
0093864	7	16		110042	16	32		160001	13	3	
0095027	11	8		110045	1	6		160002	6	4	
100000	11	40		110045	13	32		160002	7	4	
100001	1	13		110046	7	26		160002	9	23	
100001	8	23		110048	3	3		160003	6	8	
100002	11	5		110050	8	36		160003	7	8	
100073	8	2		110050	14	21		160003	10	8	
110001	2	3		110050	17	12		160003	12	29	
110001	4	22		110053	13	45		160007	5	2	
110001	6	29		110054	2	32		160007	8	26	
110001	7	21		110064	3	19		160007	11	21	
110002	6	36		110064	12	2		160007	12	10	
110002	9	36		110065	8	22		160016	6	19	
110003	2	28		110068	16	23		160027	5	14	
110004	7	15		110070	12	24		170032	2	5	
110004	8	34		110071	9	17		170045	8	11	
110004	12	3		110073	4	29		170047	8	15	
110004	14	12		110076	2	8		170049	4	34	
110004	15	3		110106	2	15		180001	8	12	
110004	17	3		120006	6	6		180002	12	23	
110006	6	18		120006	7	6		180002	15	24	
110009	4	36		120006	9	5		180003	12	28	
110009	6	27		120006	10	5		180014	10	18	
110009	9	12		120006	11	2		190001	11	41	
110009	10	14		120010	8	17		190015	2	13	
110011	6	33		120013	9	32		190016	4	10	
110012	1	12		120017	1	28		190080	8	1	
110012	2	11		120017	8	20		210009	9	30	
110012	7	18		120049	6	2		210267	11	32	
110012	8	8		120049	7	2		211063	16	6	
110013	2	2		120049	9	2		270001	16	25	
110013	3	7		120049	10	2		300000	11	4	
110013	4	2		130001	9	16		300004	1	27	
110013	6	46		130002	12	15		300008	6	12	
110013	19	4		130003	3	25		300008	9	20	
110015	19	2		130003	12	35		300008	10	11	
110016	1	18		140000	11	17		300040	15	25	
110016	11	43		140001	11	11		300043	1	34	
110016	13	4		140002	10	12		310001	6	42	
110017	11	45		140003	6	13					
110026	4	45		140004	9	21					
				140011	19	23					
				140012	14	5					
				140014	7	30					

**INDEX**

<u>Parts</u>	<u>Page</u>	<u>Ref.</u>	<u>Weight</u>	<u>Parts</u>	<u>Page</u>	<u>Ref.</u>	<u>Weight</u>	<u>Parts</u>	<u>Page</u>	<u>Ref.</u>	<u>Weight</u>
<u>No.</u>	<u>No.</u>	<u>No.</u>	<u>(g)</u>	<u>No.</u>	<u>No.</u>	<u>No.</u>	<u>(g)</u>	<u>No.</u>	<u>No.</u>	<u>No.</u>	<u>(g)</u>
310005	6	40		1298000	18	13		2100242	11	13	
310017	16	4						2100243	11	15	
310065	9	28		2049401	1	36		2100244	11	16	
310073	13	20						2100248	11	9	
310081	13	38		2100006	1	1		2100249	11	10	
310089	6	16		2100009	7	22		2100251	11	3	
310089	9	24		2100011	1	7		2100252	11	28	
310090	13	42		2100012	1	9		2100253	11	30	
310109	5	25		2100014	1	3		2100256	11	35	
				2100024	2	24		2100262	11	31	
320008	6	47		2100032	13	43		2100263	11	37	
320008	13	11		2100035	3	1		2100266	11	12	
320009	13	23		2100037	3	21		2100269	11	27	
320010	13	46		2100047	3	4		2100271	11	42	
				2100053	1	17		2100272	5	29	
330000	3	17		2100063	4	1		2100275	12	21	
330008	3	16		2100088	9	3		2100276	12	22	
				2100088	10	3		2100277	12	19	
350007	19	25		2100098	5	34		2100278	12	20	
				2100099	8	25		2100279	12	27	
390097	2	18		2100105	5	17		2100280	12	16	
390098	2	17		2100117	5	19		2100281	12	14	
390140	21	1		2100136	6	11		2100283	12	13	
390143	21	2		2100137	6	7		2100284	12	17	
390144	21	3		2100138	6	14		2100288	11	20	
390145	21	4		2100144	6	3		2100289	12	25	
390146	21	5		2100145	6	32		2100336	19	21	
390147	21	6		2100152	6	39		2100337	19	15	
390148	21	7		2100160	7	1		2100338	19	16	
390177	2	16		2100161	7	7		2100339	19	5	
				2100161	9	9		2100346	15	23	
910000	20	10		2100161	10	7		2100349	14	6	
910001	20	7		2100162	7	5		2100353	14	7	
910003	20	14		2100164	7	11		2100354	14	4	
				2100165	7	10		2100363	13	2	
911001	20	6		2100166	7	25		2100369	13	14	
911002	20	5		2100167	7	28		2100374	19	24	
911006	20	9		2100168	7	29		2100375	19	13	
911060	20	19		2100173	7	3		2100385	14	1	
				2100174	7	19		2100502	6	28	
930052	20	12		2100176	6	15		2100518	8	19	
930053	20	13		2100177	15	26		2100533	6	41	
930055	20	27		2100181	8	3		2100534	2	27	
				2100189	8	28		2100535	6	43	
1090133	18	21		2100192	8	21		2100536	6	44	
				2100193	8	13		2100538	2	19	
1094011	18	3		2100197	8	18		2100580	8	5	
				2100199	8	30		2100602	12	11	
1096000	18	12		2100211	10	10		2100625	5	3	
1096004	18	28		2100215	10	1		2100642	5	36	
1096005	18	29		2100219	10	9		2100642	6	20	
				2100221	9	19		2100667	9	25	
1097000	18	4		2100227	9	15		2100671	11	22	
1097001	18	9		2100229	4	38		2100672	11	23	
				2100241	11	14		2100673	11	24	

**INDEX**

Parts No.	Page No.	Ref. No.	Weight (g)	Parts No.	Page No.	Ref. No.	Weight (g)	Parts No.	Page No.	Ref. No.	Weight (g)
2100674	11	25		2109006	12	31		2150046	5	27	
2100854	9	33		2109017	15	17		2150047	5	28	
2100855	2	26		2109018	15	18		2150048	5	21	
2100856	2	31		2109019	15	19		2150049	5	20	
2100861	3	13		2109067	12	32		2150050	5	35	
2100863	1	21		2109200	6	35		2150051	6	17	
2100864	1	20		2109201	10	16		2150055	13	36	
2100865	12	1		2109320	14	23		2150056	13	37	
2100866	12	4		2109320	15	27		2150057	6	24	
2100867	12	5		2109322	9	29		2150058	6	25	
2100868	12	8		2109347	10	15		2150060	7	9	
2100869	12	6		2109932	18	1		2150063	12	9	
2100870	12	7						2150064	11	1	
2100872	5	15		2110026	3	6		2150065	11	18	
2100873	3	23		2110027	3	5		2150066	11	19	
2100874	3	24		2110183	5	6		2150067	12	34	
2100875	1	26		2110184	5	5		2150069	5	33	
2100884	9	18						2150070	9	6	
2100890	9	37		2111050	16	2		2150071	9	4	
2100892	9	27		2111051	16	3		2150072	9	7	
2100895	13	40		2111055	16	9		2150075	9	8	
2100896	13	39		2111056	16	13		2150075	11	7	
2100899	6	5		2111057	16	15		2150076	10	4	
2100900	9	1		2111058	16	22		2150084	9	14	
2100902	10	6		2111059	16	12		2150094	13	25	
2100903	9	22		2111060	16	19		2150095	13	24	
2100918	3	20		2111061	16	17		2150096	5	9	
2100921	3	2		2111062	16	16		2150097	13	28	
2100926	13	16		2111066	16	18		2150100	5	11	
2100927	13	17		2111067	16	20		2150105	6	1	
2100928	13	18						2150110	4	28	
2100929	13	19		2129423	2	29		2150111	4	31	
2100935	13	1						2150112	4	32	
2100957	13	15		2150015	1	11		2150114	4	27	
2100958	13	12		2150016	2	1		2150115	4	23	
2100961	3	11		2150017	3	18		2150116	4	15	
				2150018	2	4		2150117	9	34	
2101011	16	24		2150019	7	20		2150118	10	13	
2101059	16	31		2150020	7	17		2150119	4	39	
2101435	14	3		2150021	7	23		2150120	4	42	
2101450	19	8		2150022	3	12		2150121	4	43	
2101451	19	9		2150023	2	10		2150123	4	41	
				2150024	2	12		2150124	4	21	
2107219	17	9		2150025	2	14		2150125	2	7	
2107643	8	41		2150026	1	19		2150130	9	11	
2107643	14	15		2150027	4	35		2150132	4	33	
2107643	17	6		2150035	6	37		2150138	8	16	
				2150038	5	10		2150139	8	24	
2108003	14	22		2150039	5	16		2150140	8	27	
2108004	6	30		2150040	5	24		2150141	8	29	
2108015	15	13		2150041	5	26		2150145	8	4	
2108016	15	11		2150042	5	32		2150146	8	7	
2108017	15	12		2150043	5	18		2150147	8	9	
				2150044	5	30		2150148	8	10	
2109005	12	30		2150045	5	31		2150150	6	49	

