

Teileliste und Naehinrichtungen
Spare Parts List and Sewing Equipment

910

DÜRKOPP ADLER AG

910

Inhaltsverzeichnis	Tafel / Table	Table of contents
Nadelstange	1	Needle bar
Armwelle	2	Arm shaft
Fuesschenlueftung	3	Sewing foot lifting
Klammerlueftung	4, 5	Clamp lifting
Greifertreiber	6	Hook driver
Fadenspannung	7	Thread tension
Fadenabschneider	8 - 10	Thread trimmer
Transporteinrichtung (Klammer)	11	Feed drive (Clamp)
Transporteinrichtung (Schrittmotore)	12	Feed drive (Step motors)
Spuler	13	Winder
Rahmen und Abdeckung	14	Frame and covering
Schmierung	15	Lubrication
Gestell	16	Stand
Elektroteile	17	Electronics
Bedienfeld	18	Control panel
Wartungseinheit	19	Maintenance unit
Klammersaetze	20	Clamp sets
Beipack / Zusatzausstattung	21, 22	Accessories / Optional equipment

Alle Rechte vorbehalten.

Eigentum der Dürkopp Adler AG und urheberrechtlich geschützt. Jede, auch auszugsweise Wiederverwendung dieser Inhalte ist ohne vorheriges schriftliches Einverständnis der Dürkopp Adler AG verboten.

All rights reserved.

Property of Dürkopp Adler AG and copyrighted. Reproduction or publication of the content in any manner, even in extracts, without prior written permission of Dürkopp Adler AG, is prohibited.

Copyright © Dürkopp Adler AG - 2007

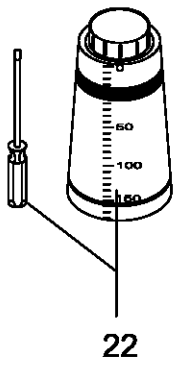
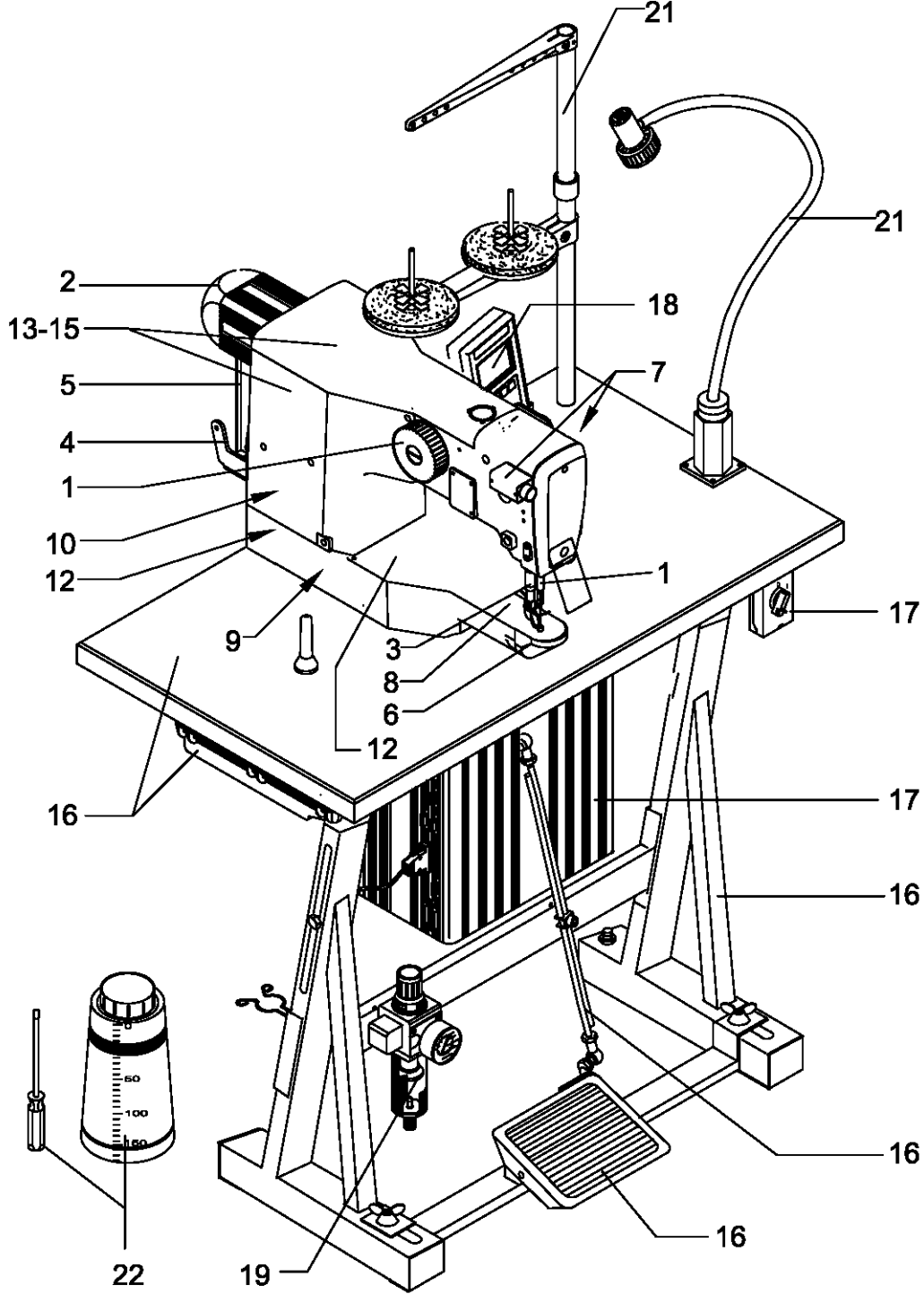

20

11

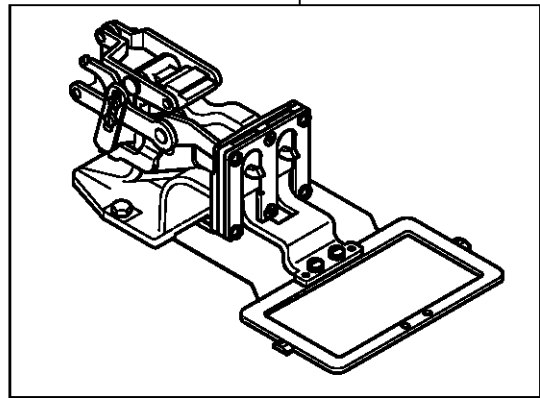
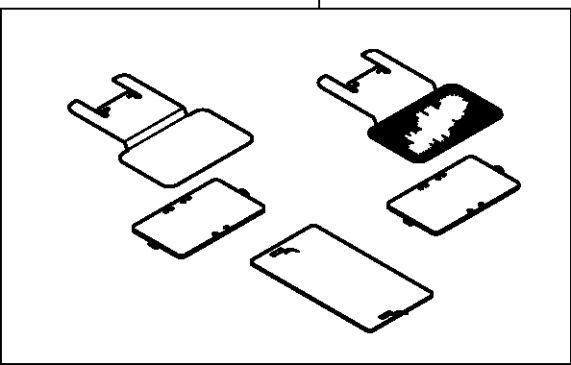

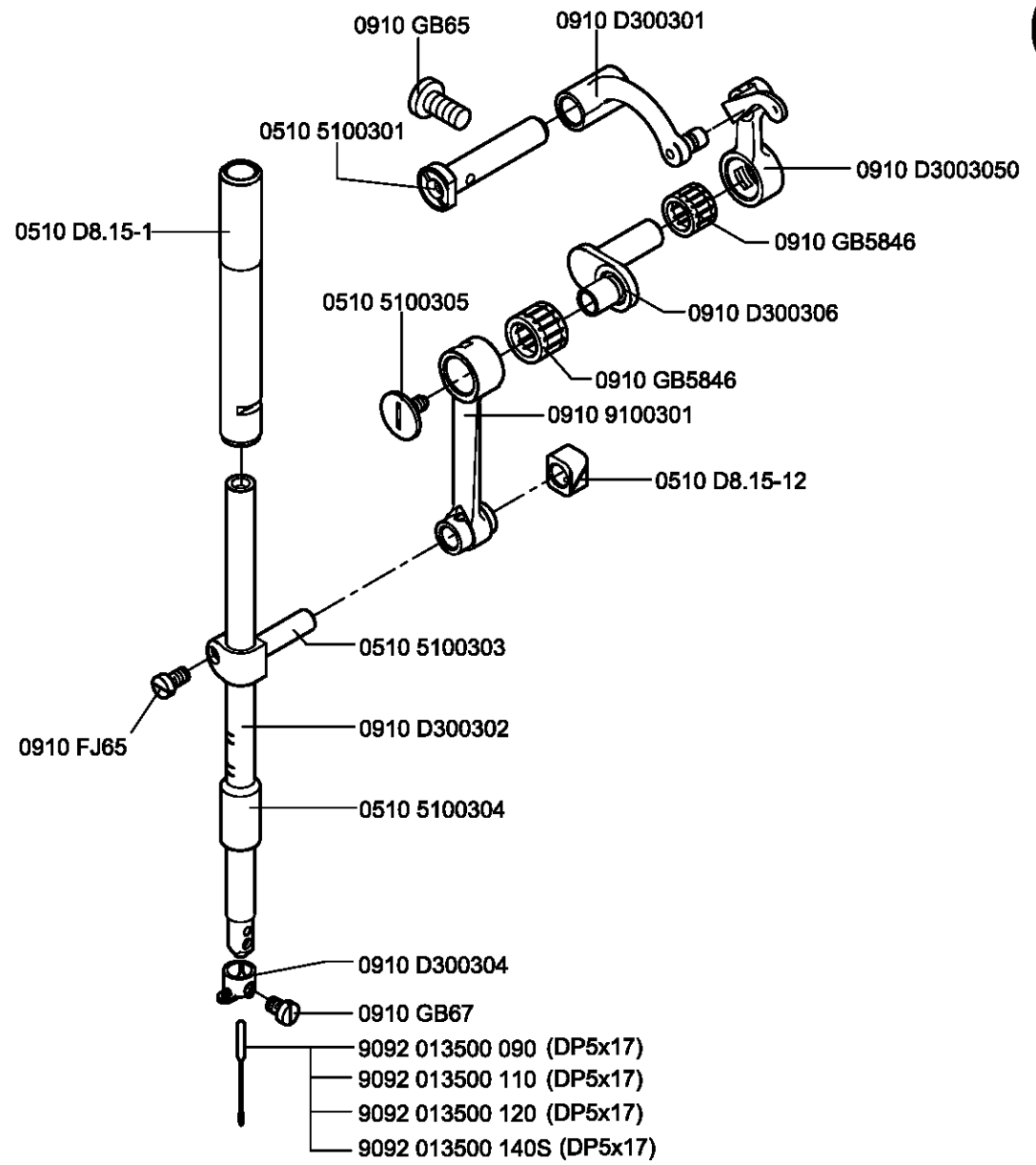
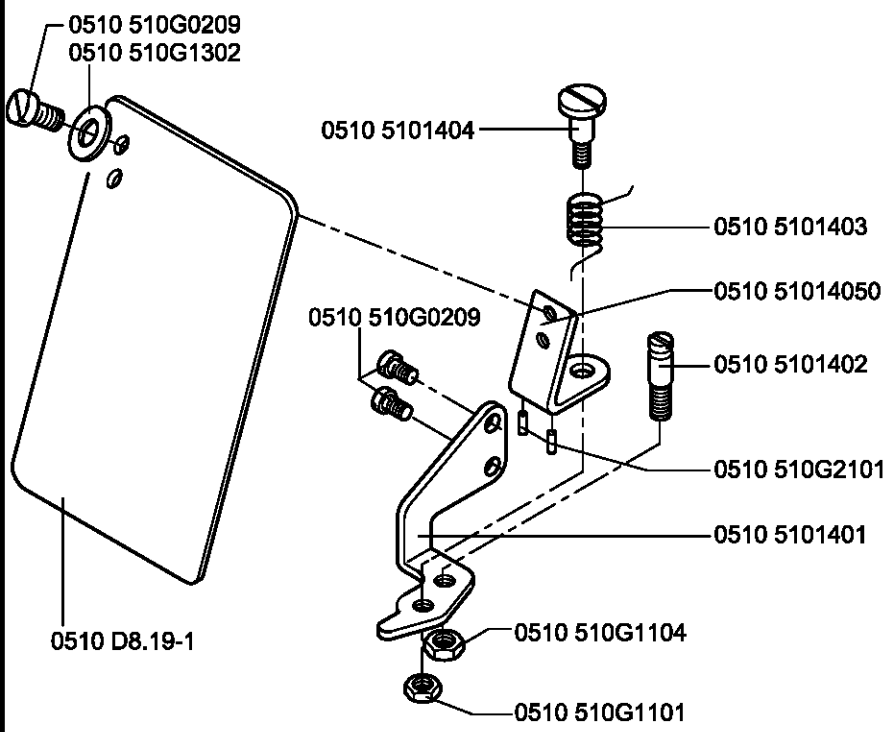

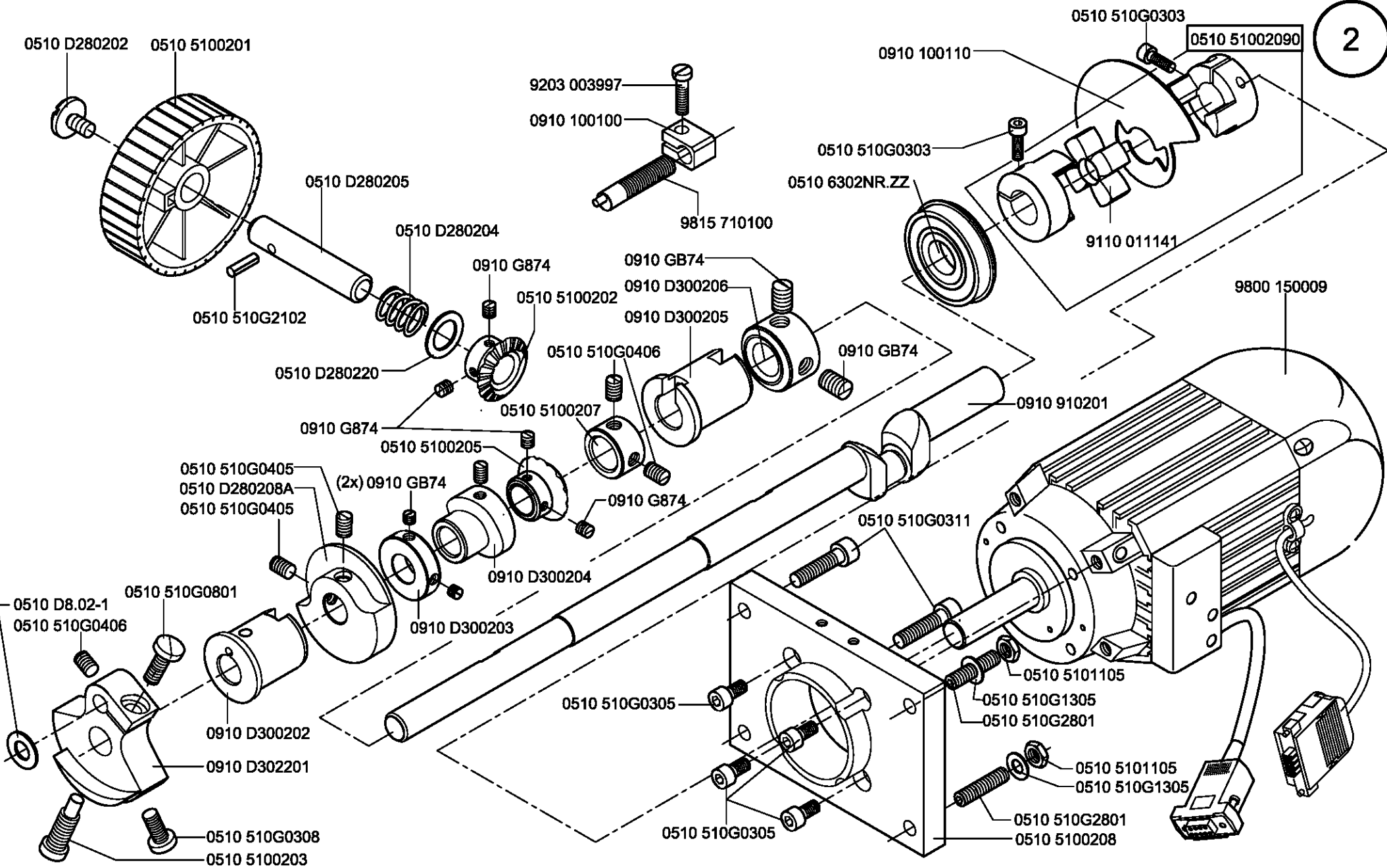

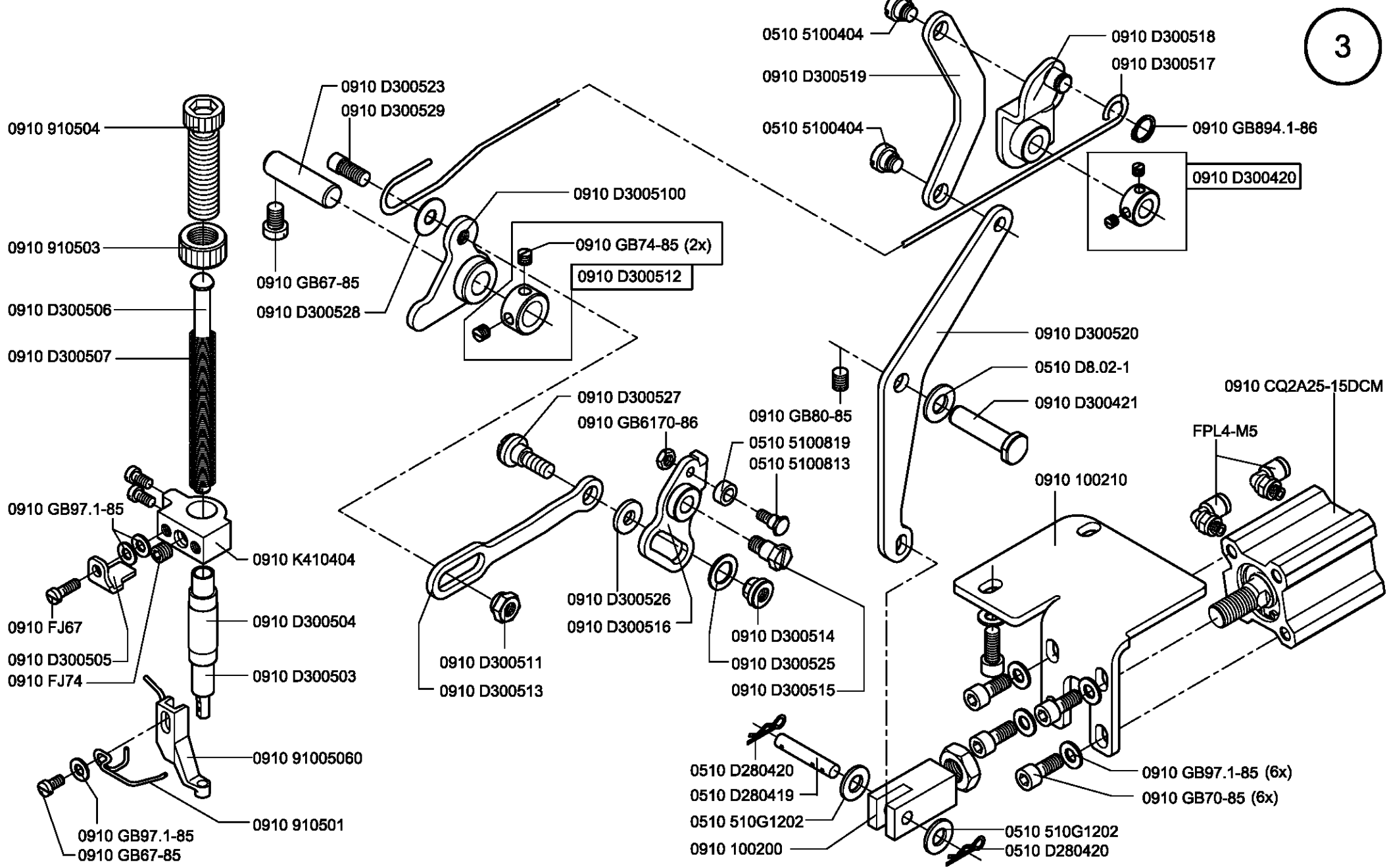

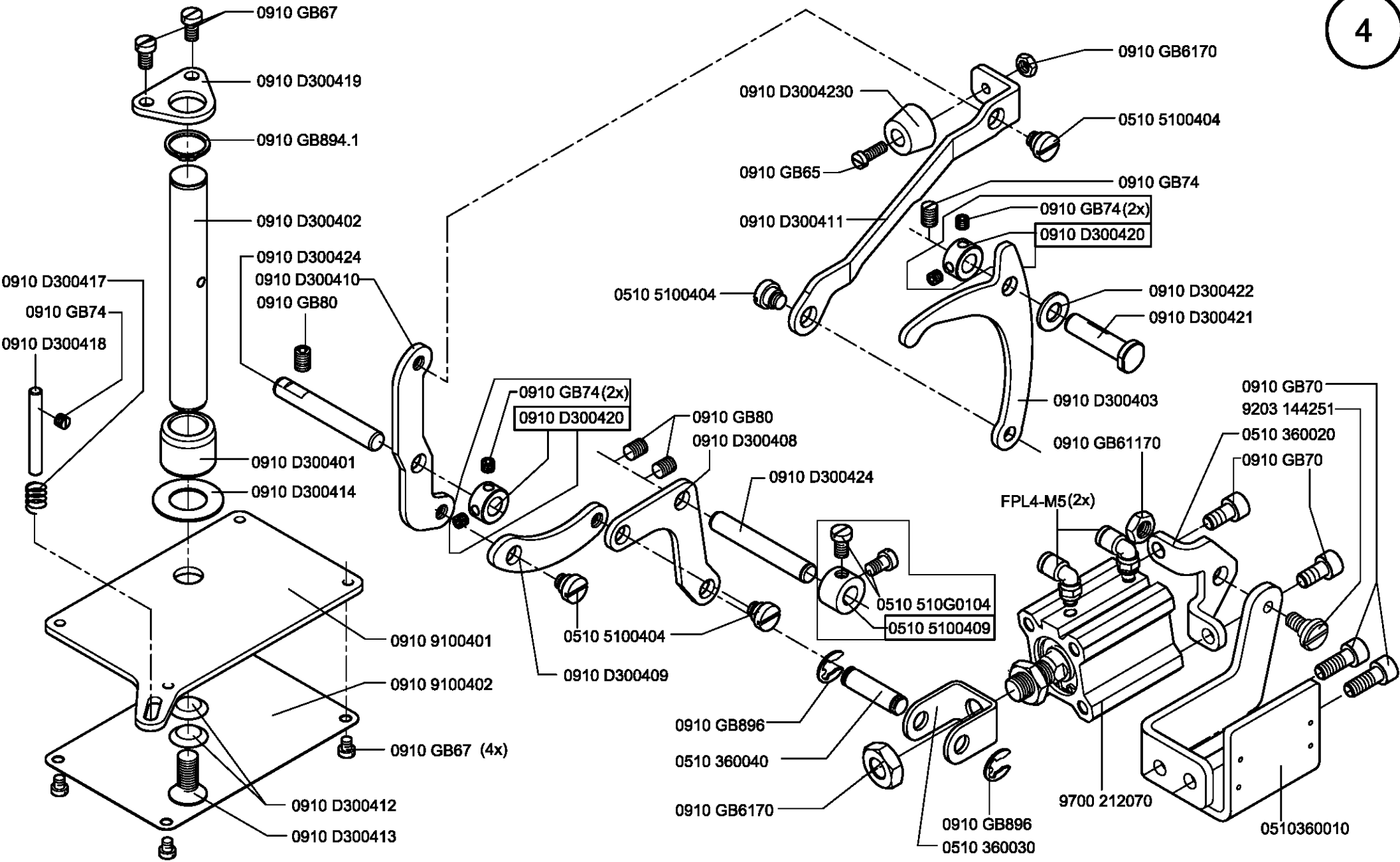

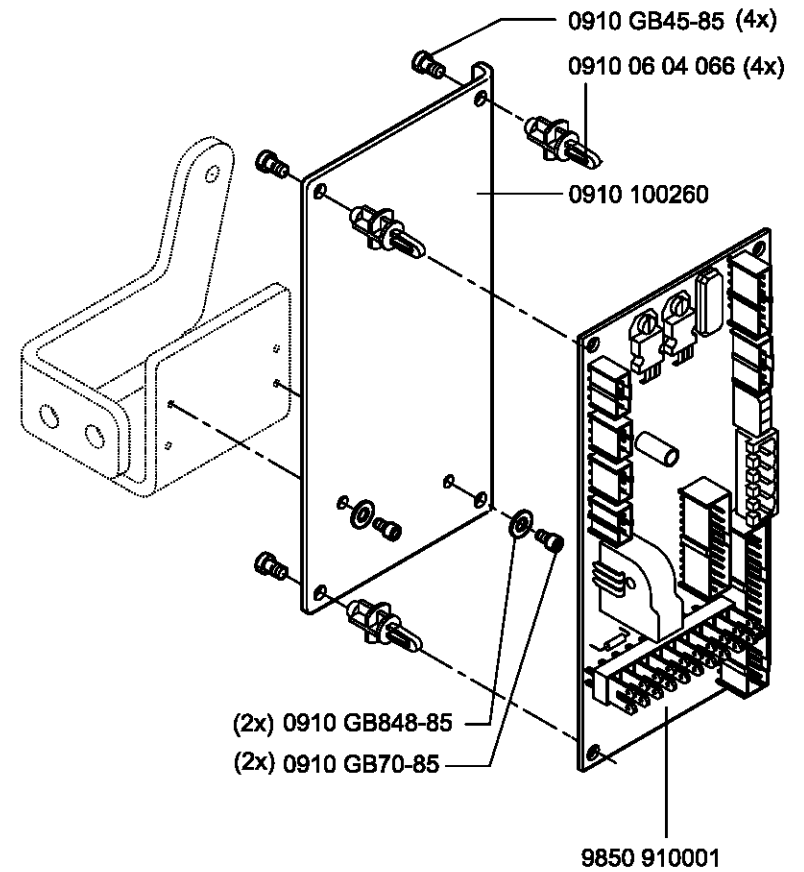
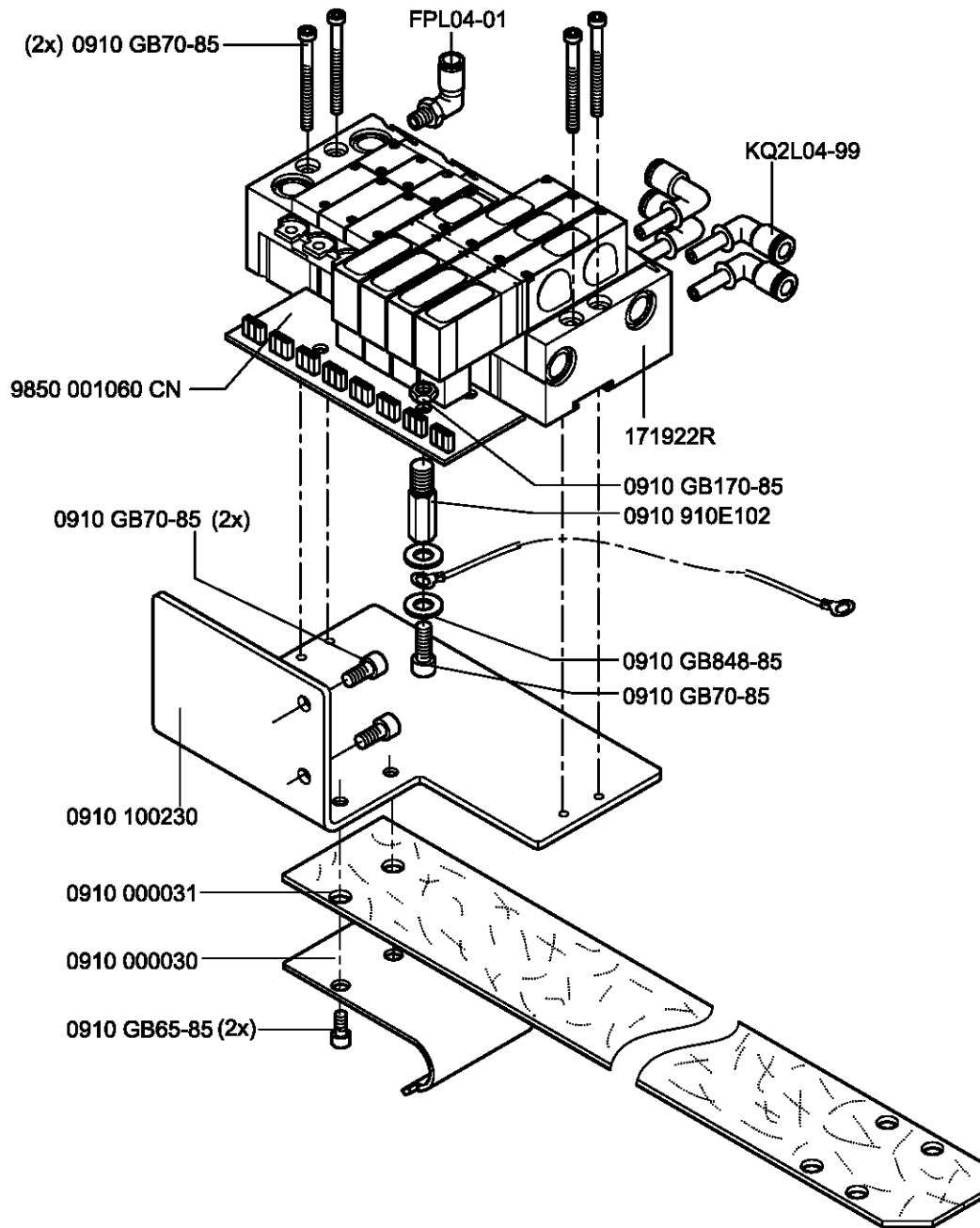

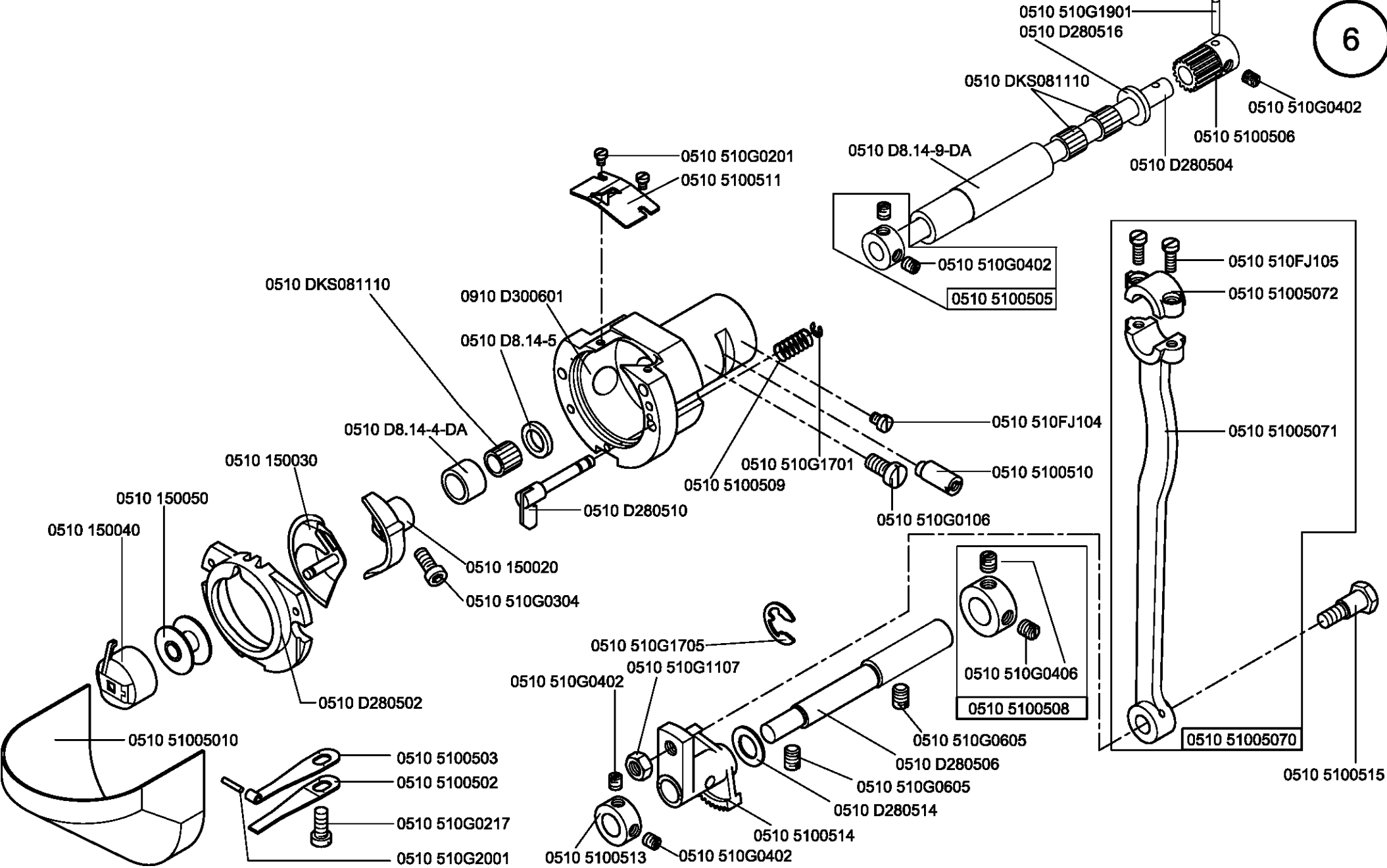

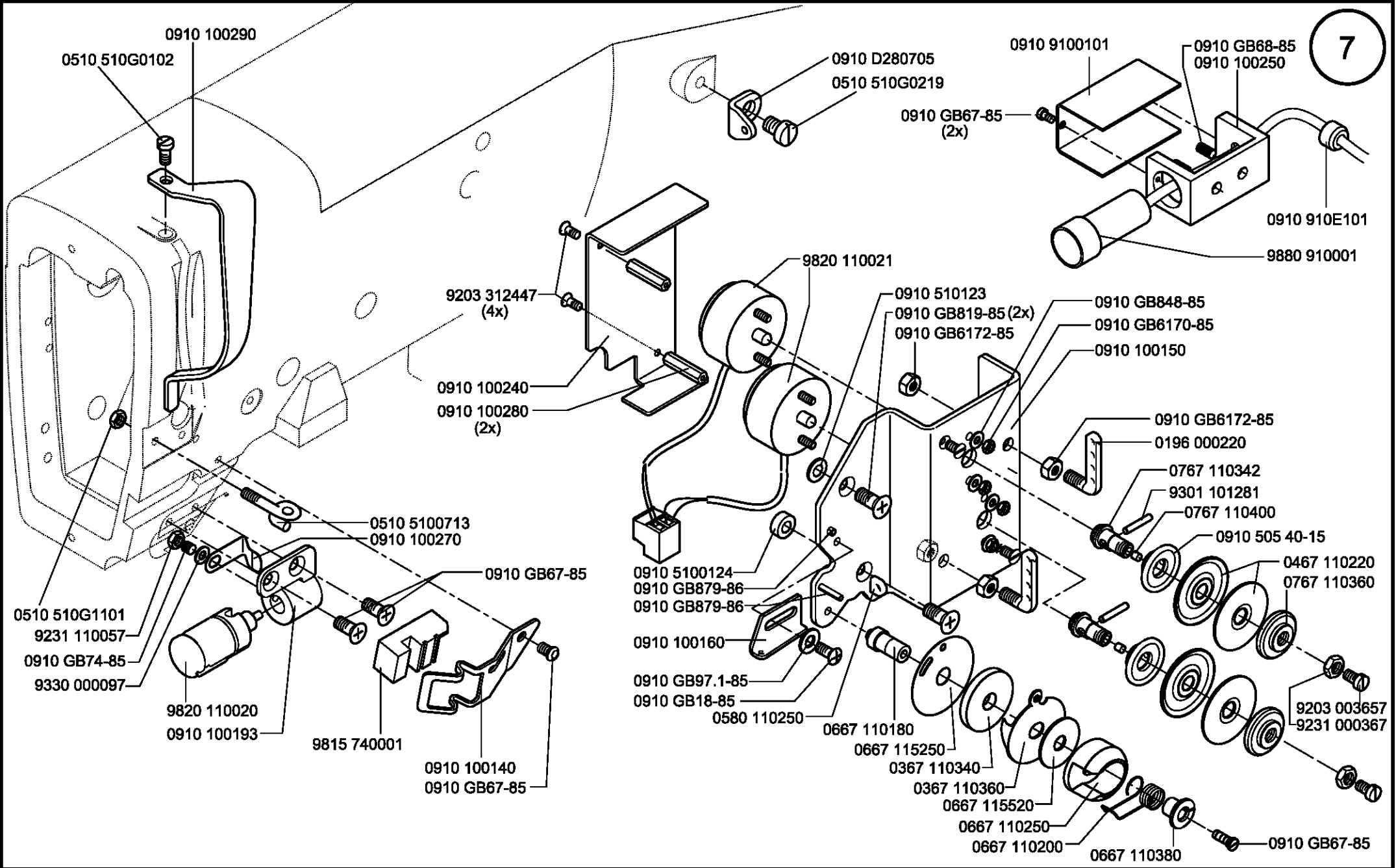

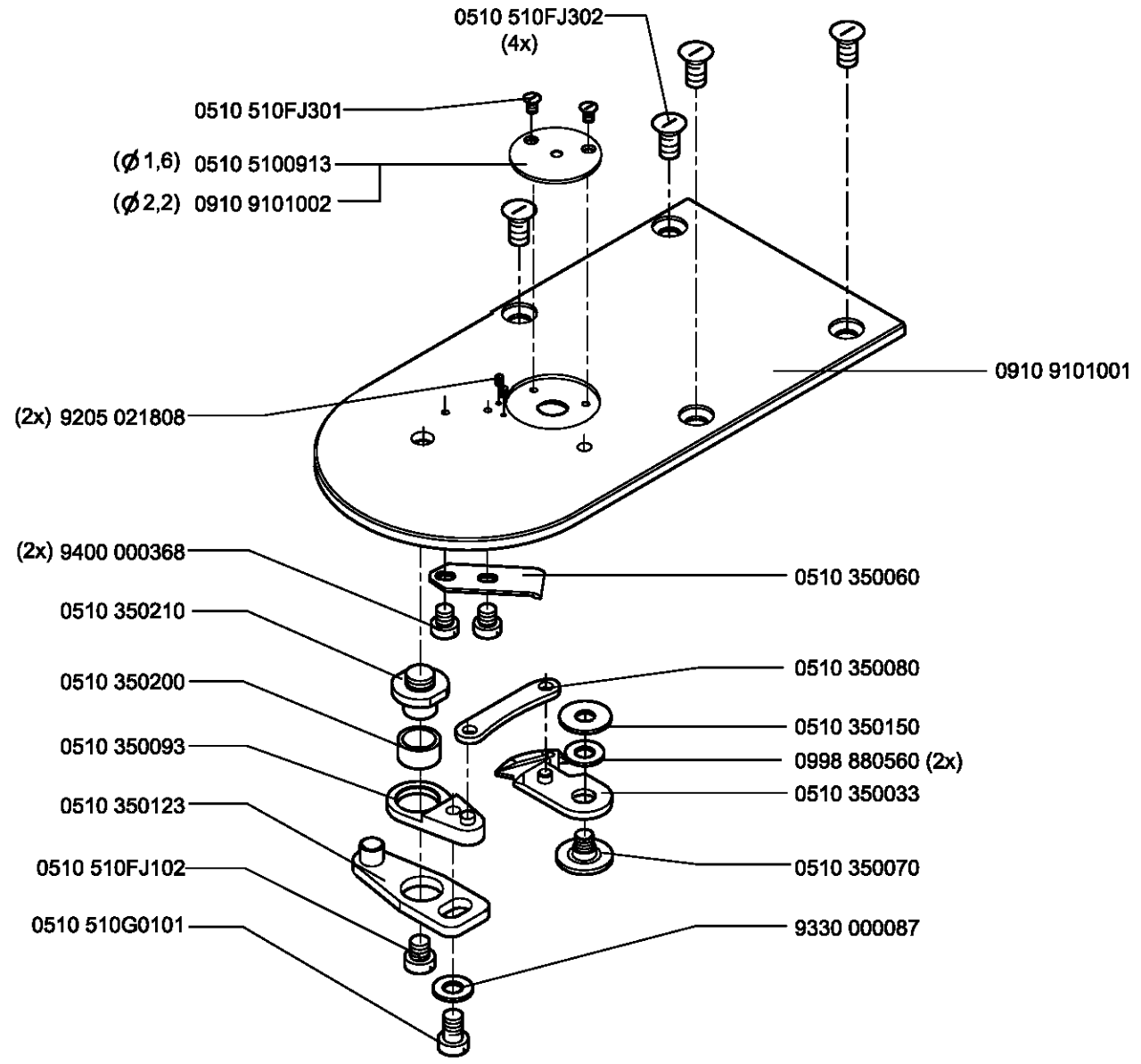

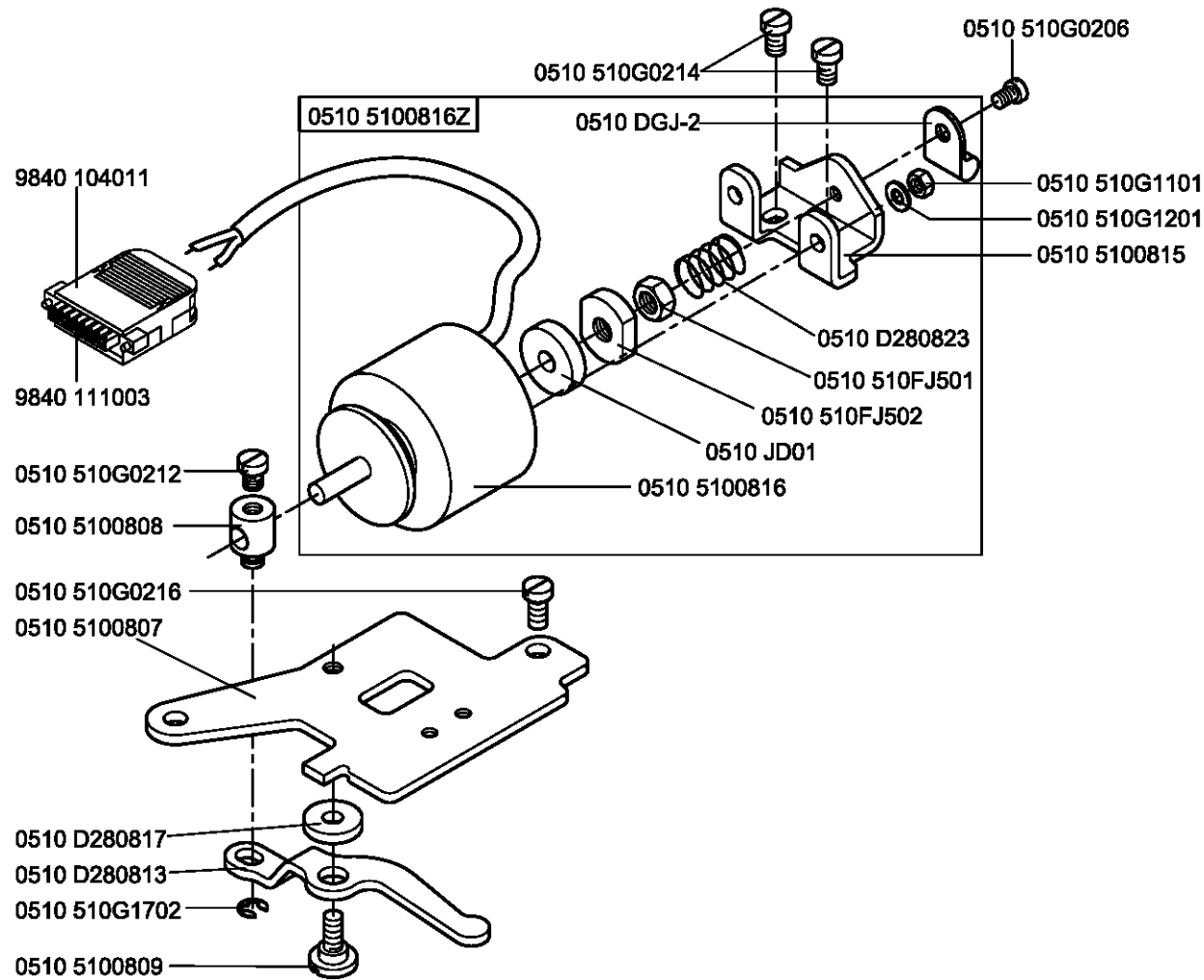

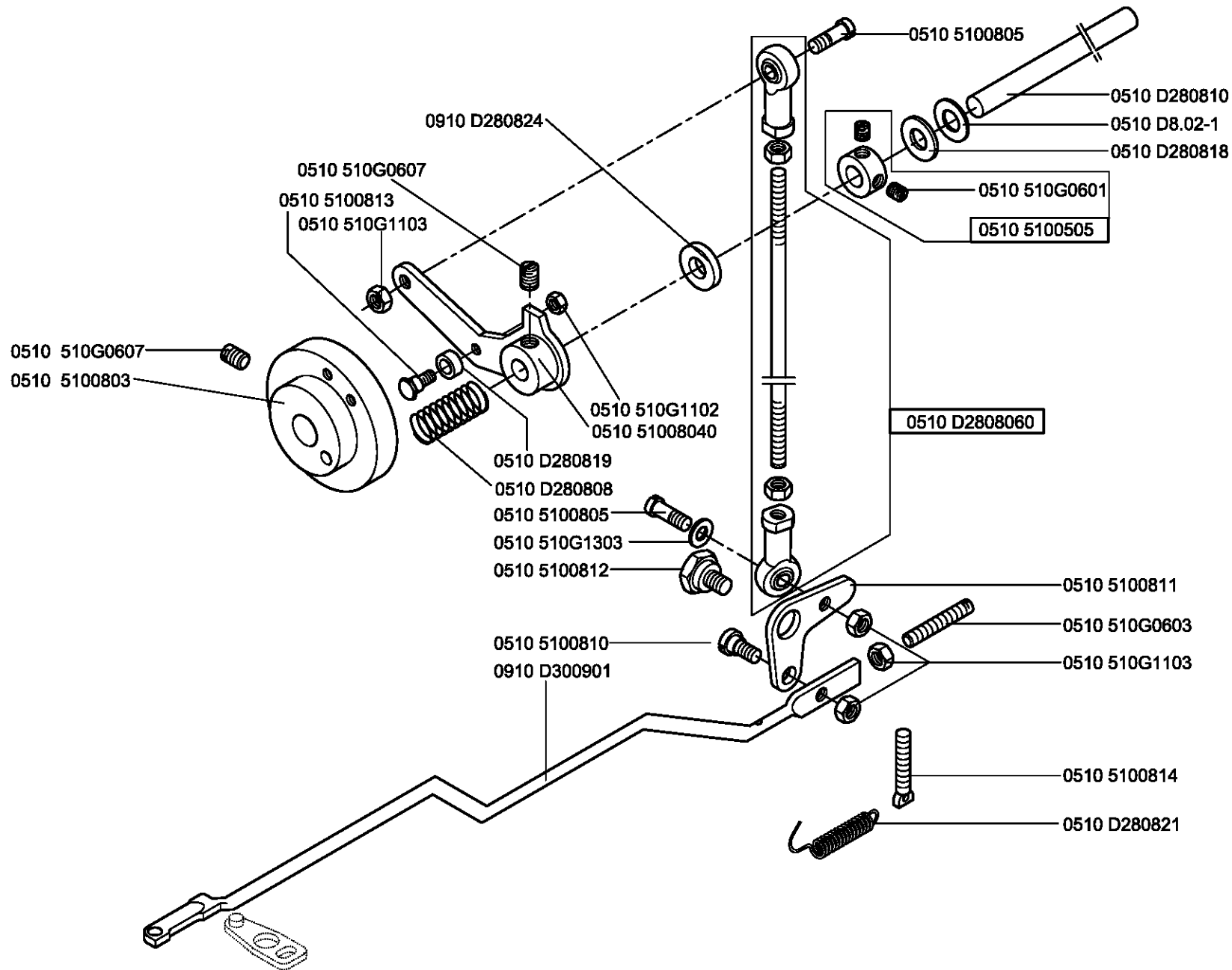

0910 91012

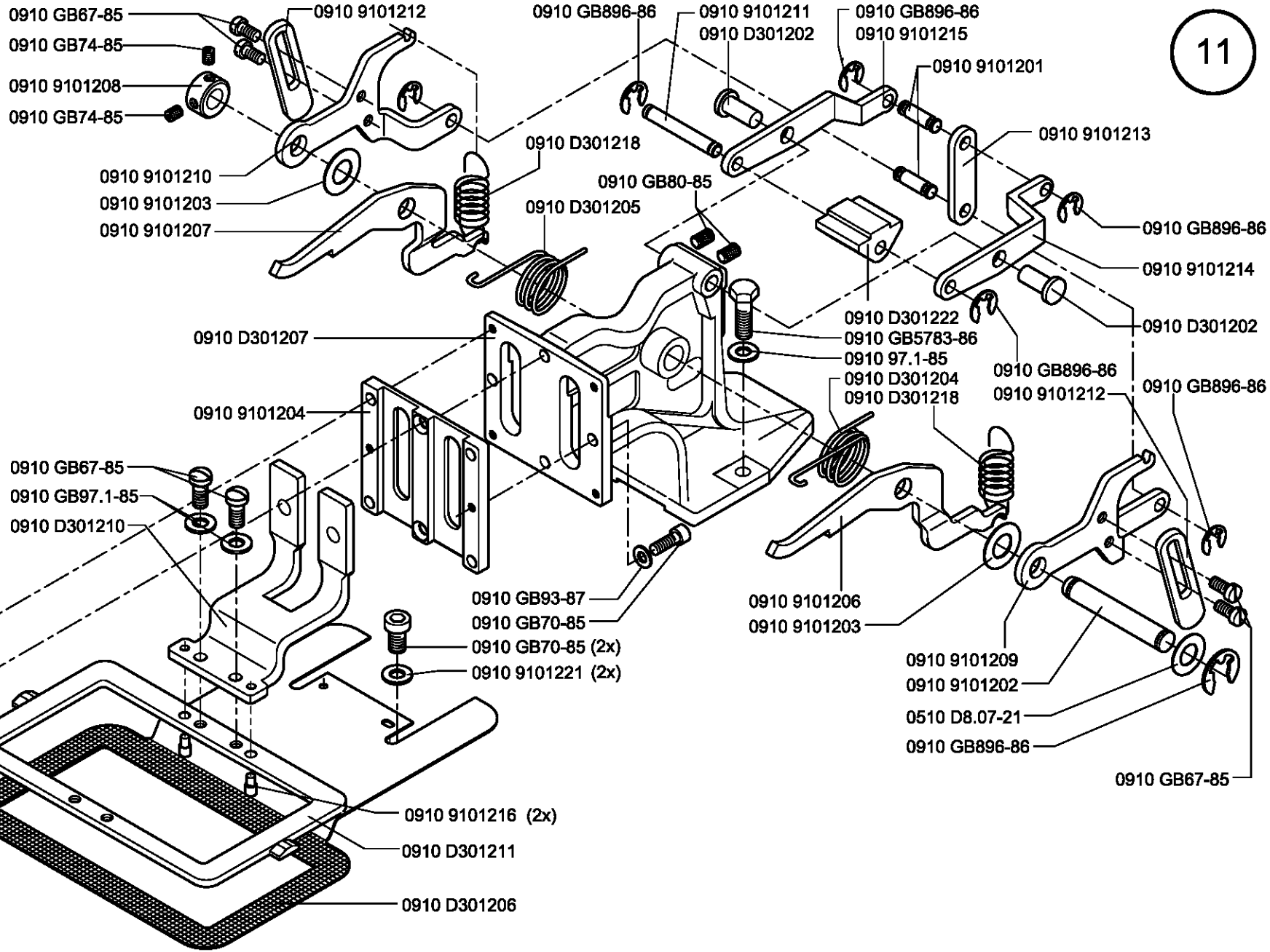

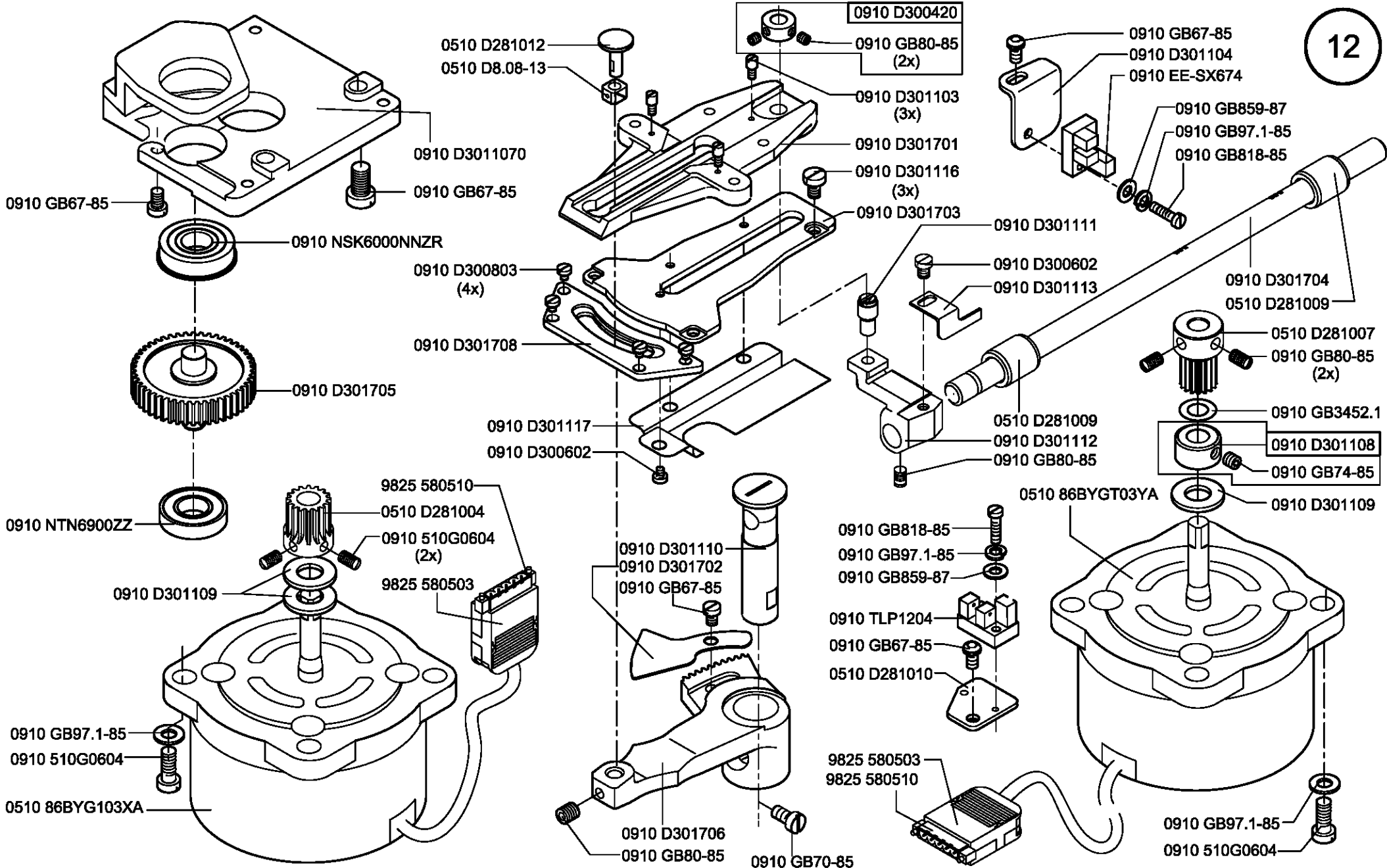

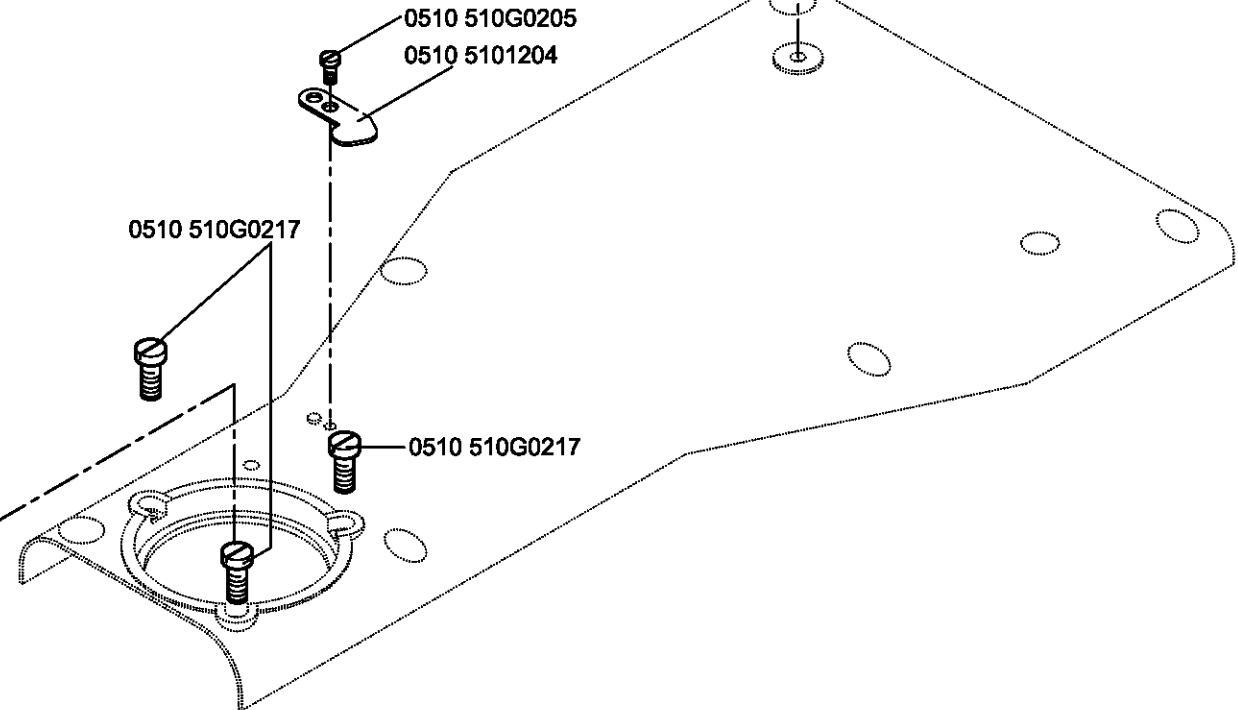
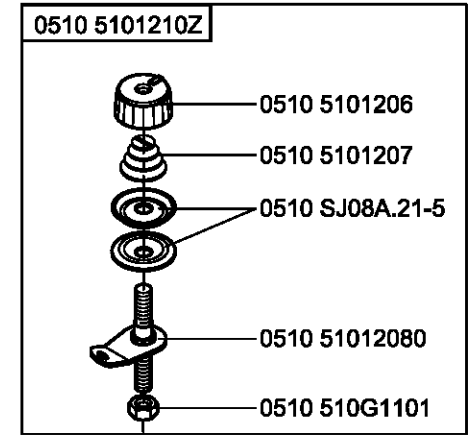
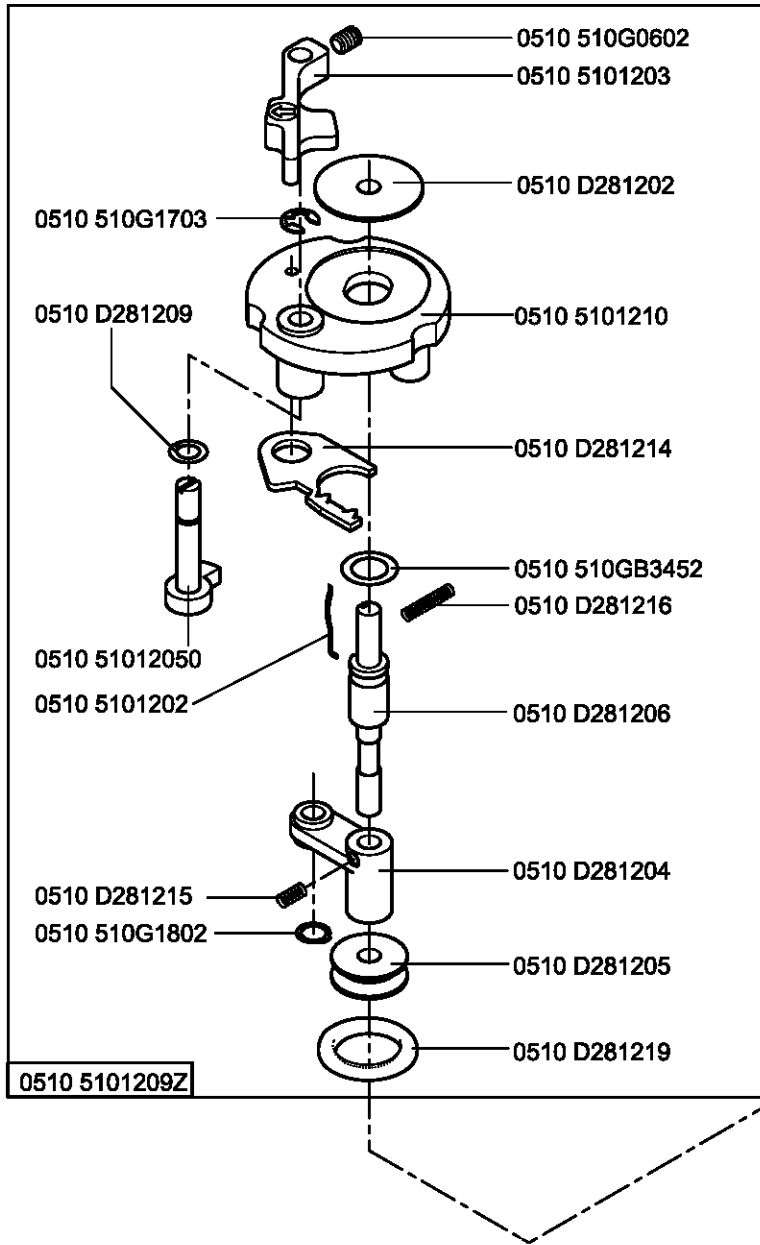

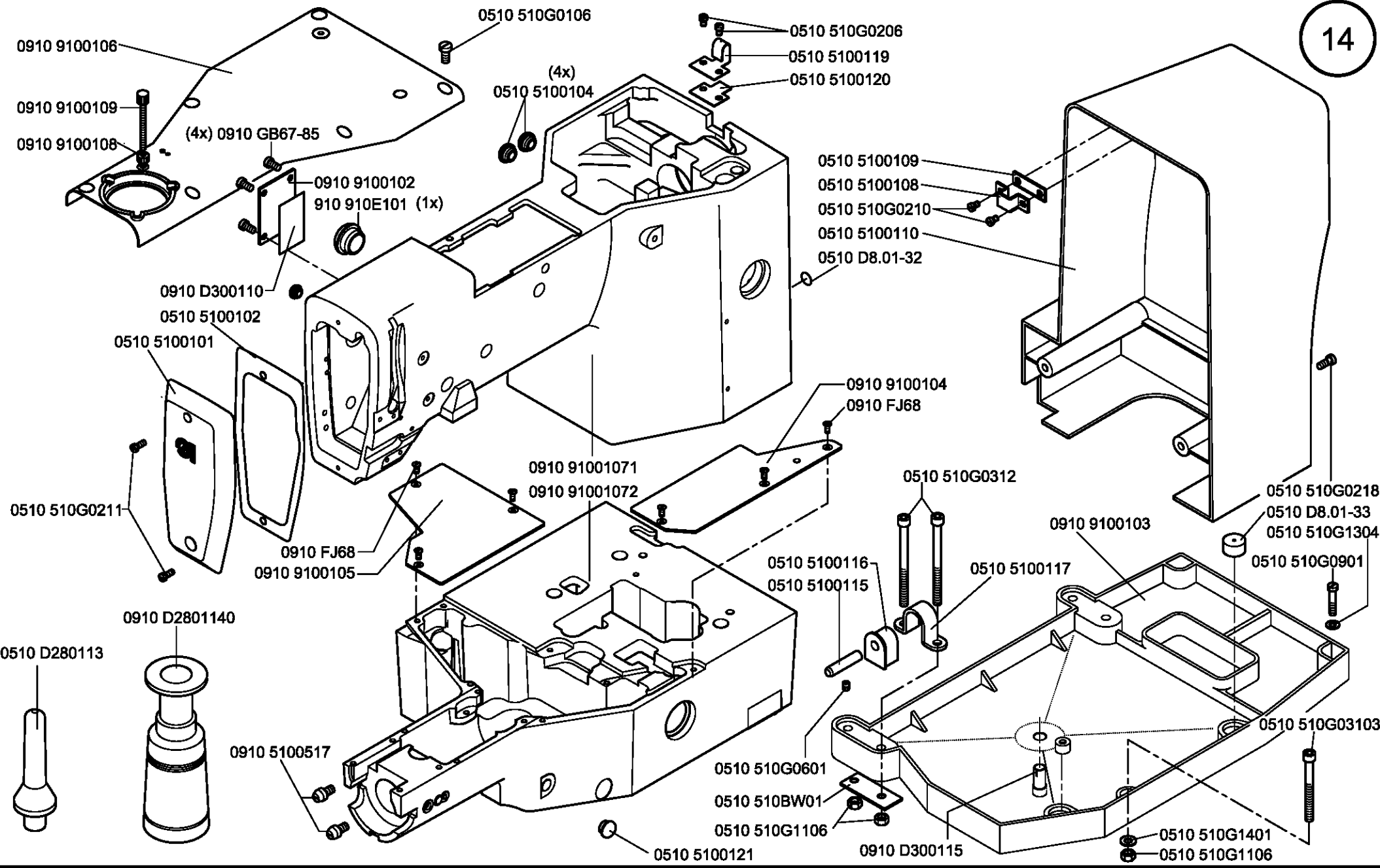

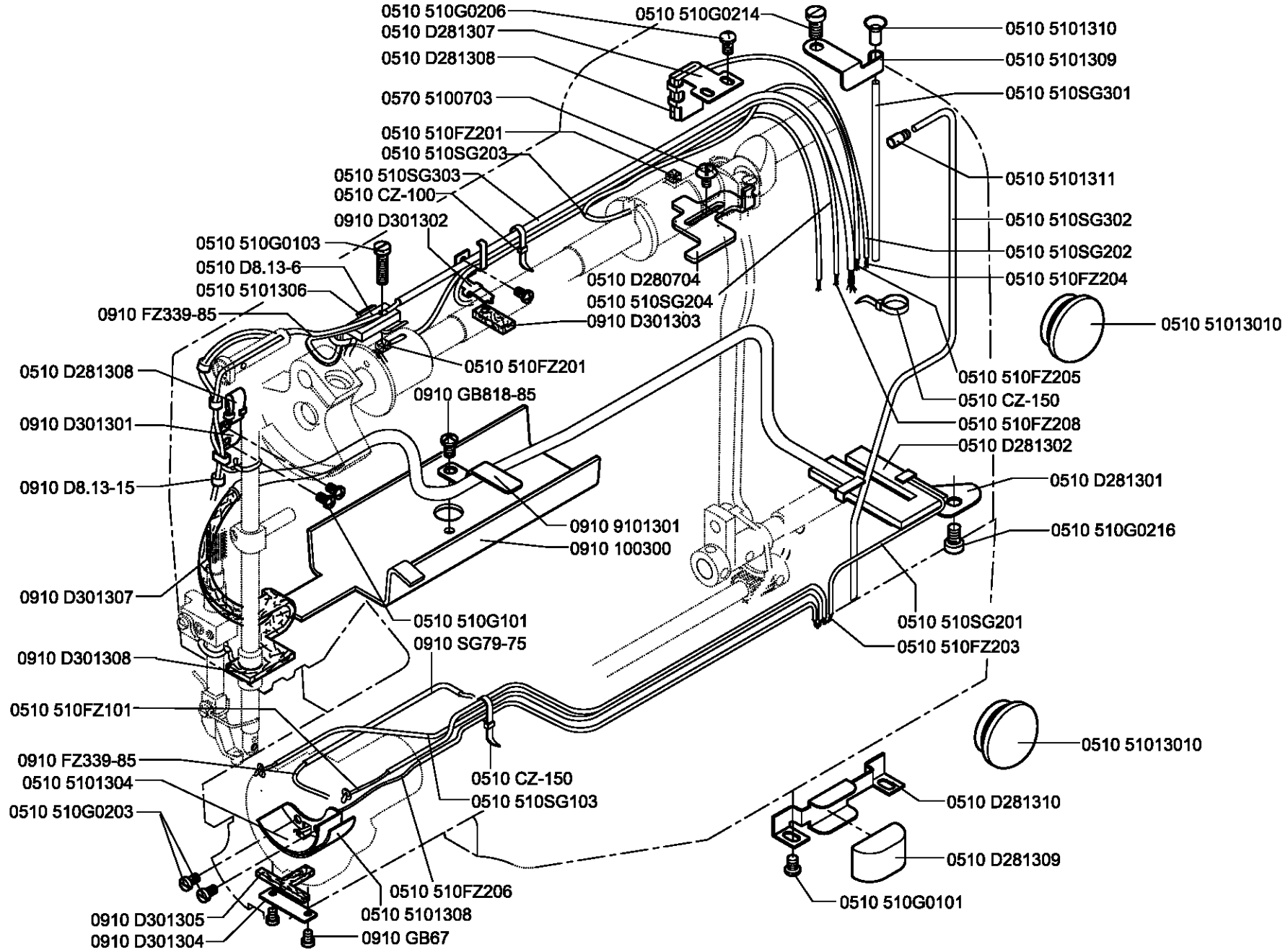

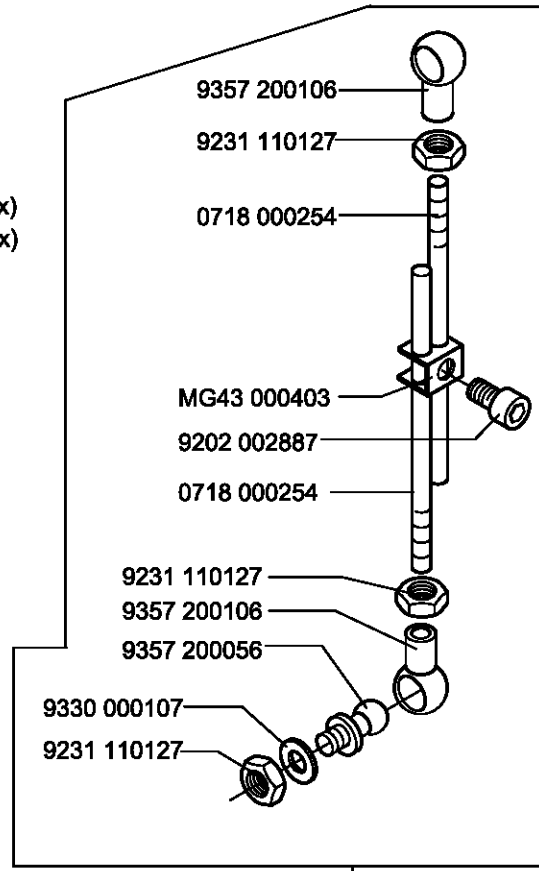
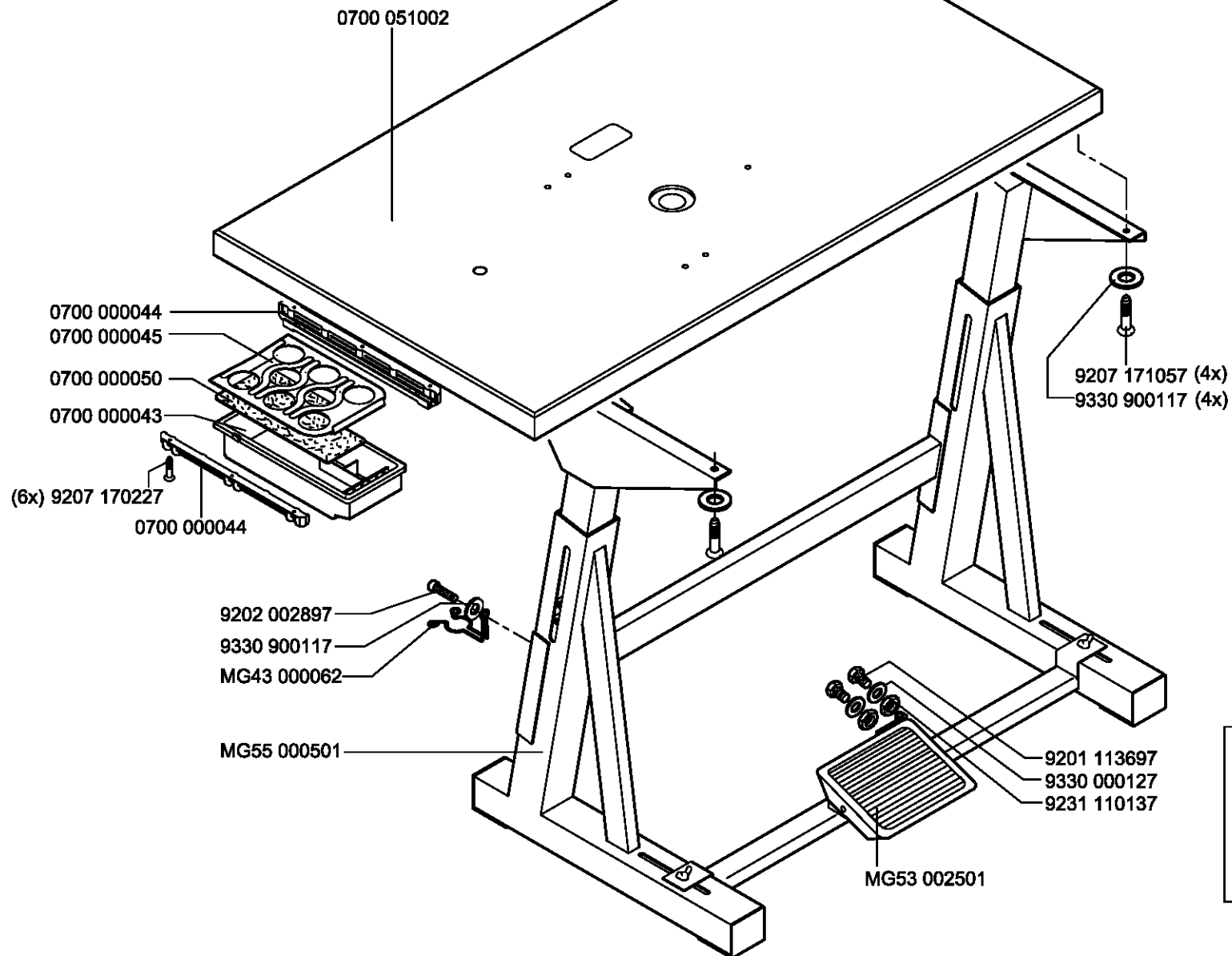

MG43 000451

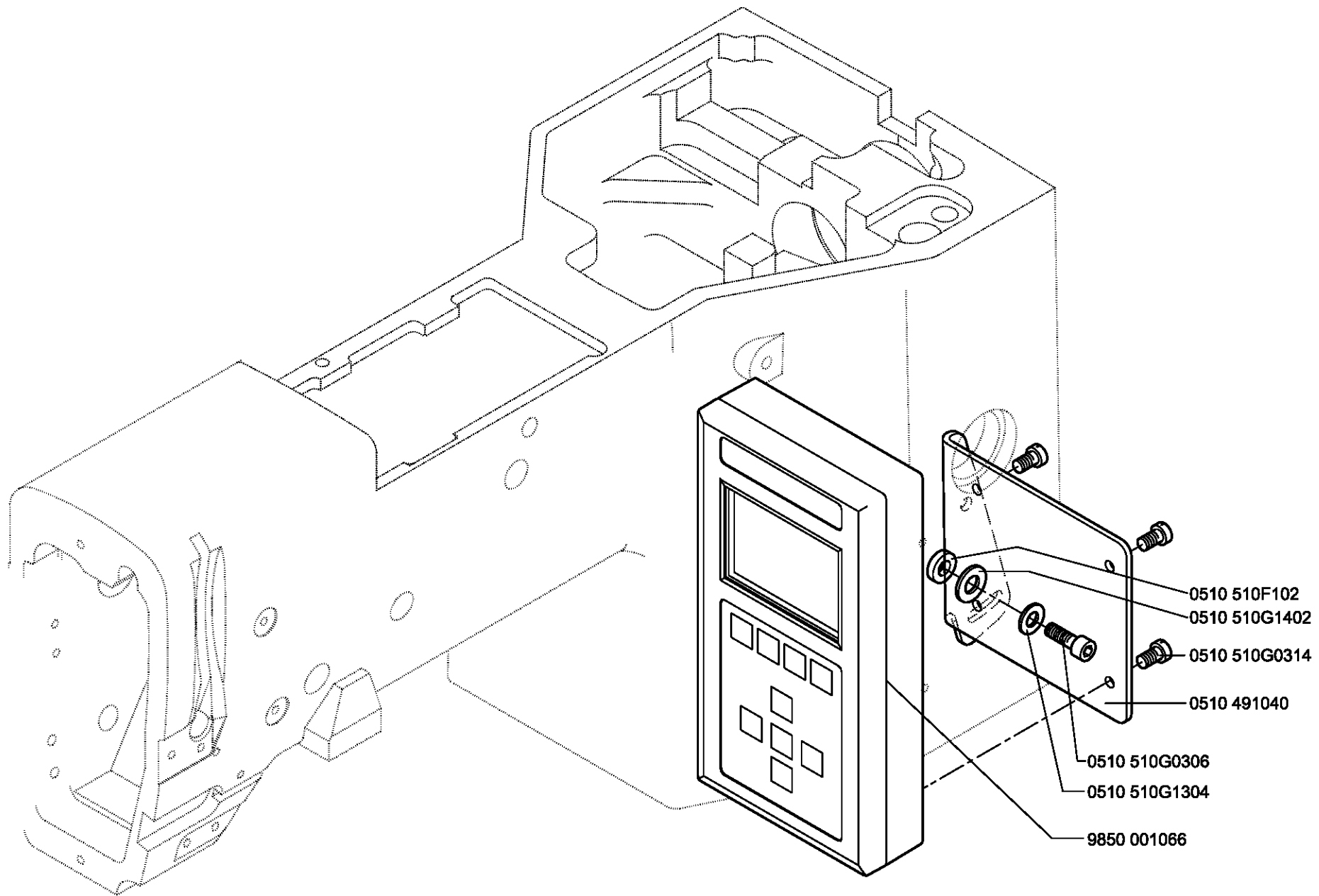

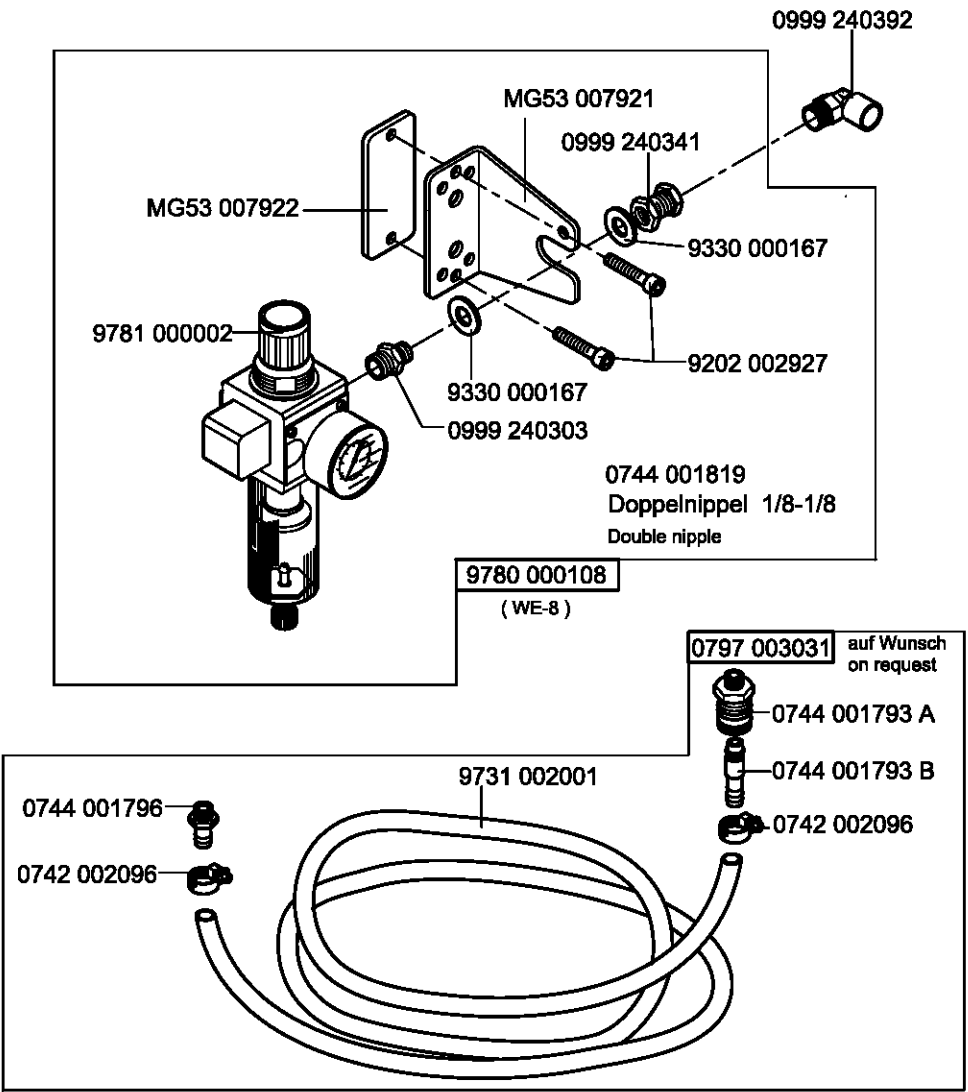

0910 417524

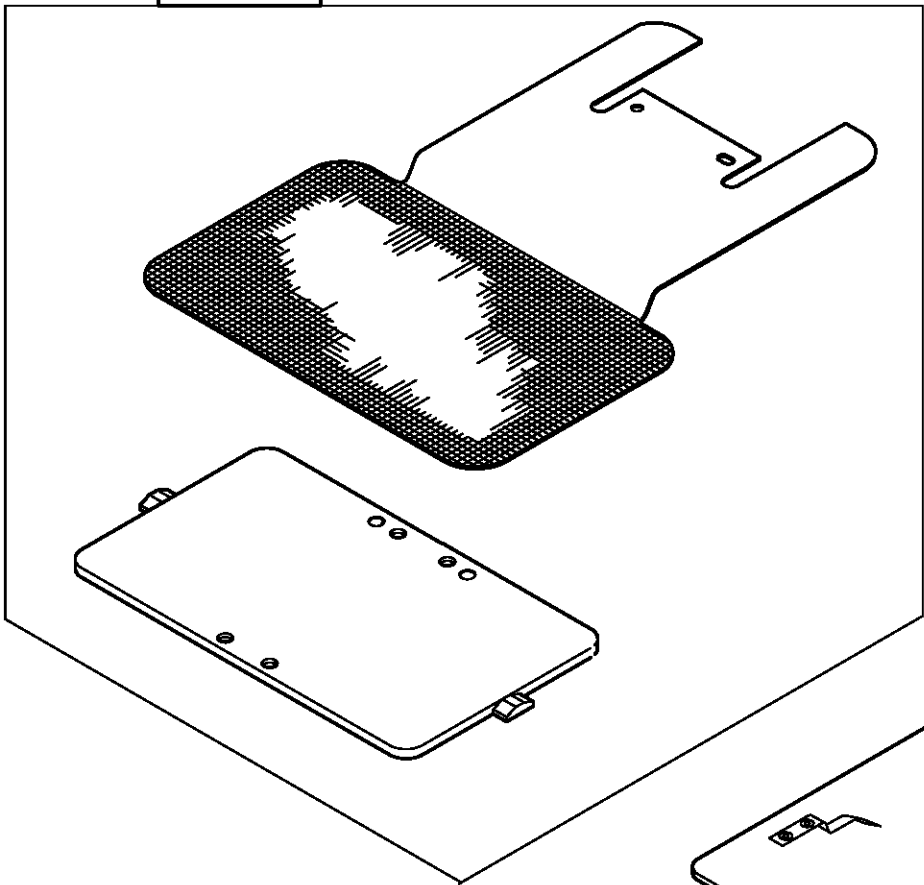

0910 417514

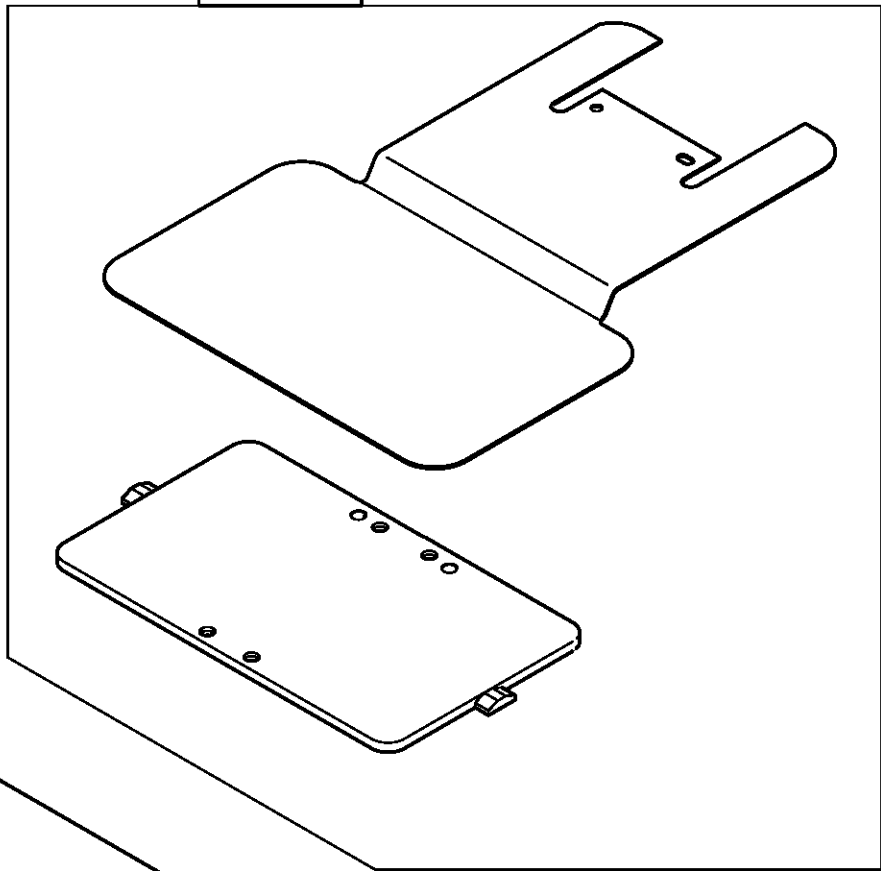

0910 417533

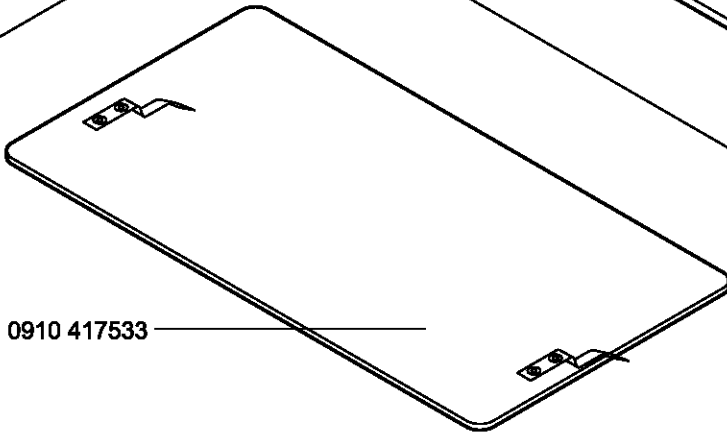

auf Wunsch
on request

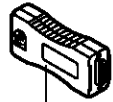

9850 910010 GP01
(mit 910 - Software)
(with 910 - software)

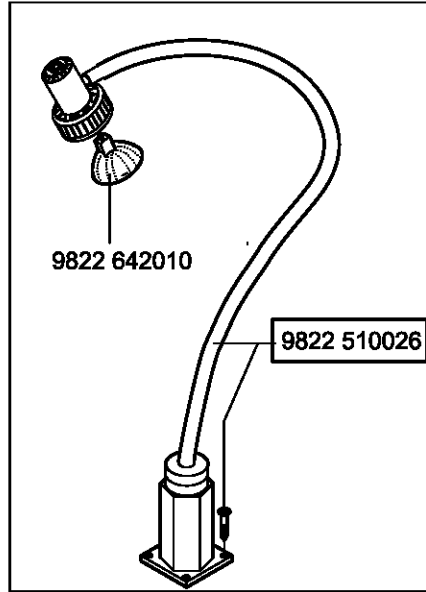

9822 642010

9822 510026

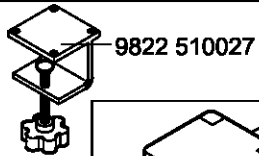

9822 510027

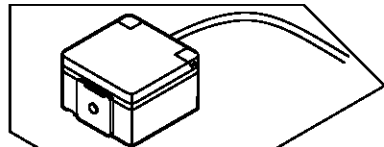

9870 001021

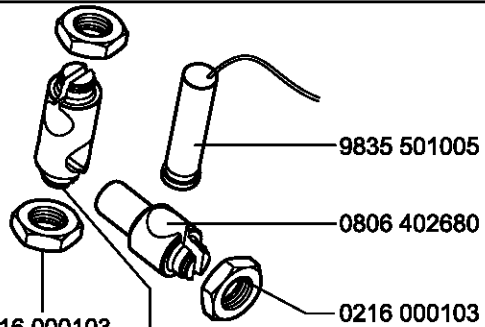

0216 000103
0806 402670

0510 590034

9835 501005

0806 402680

0216 000103

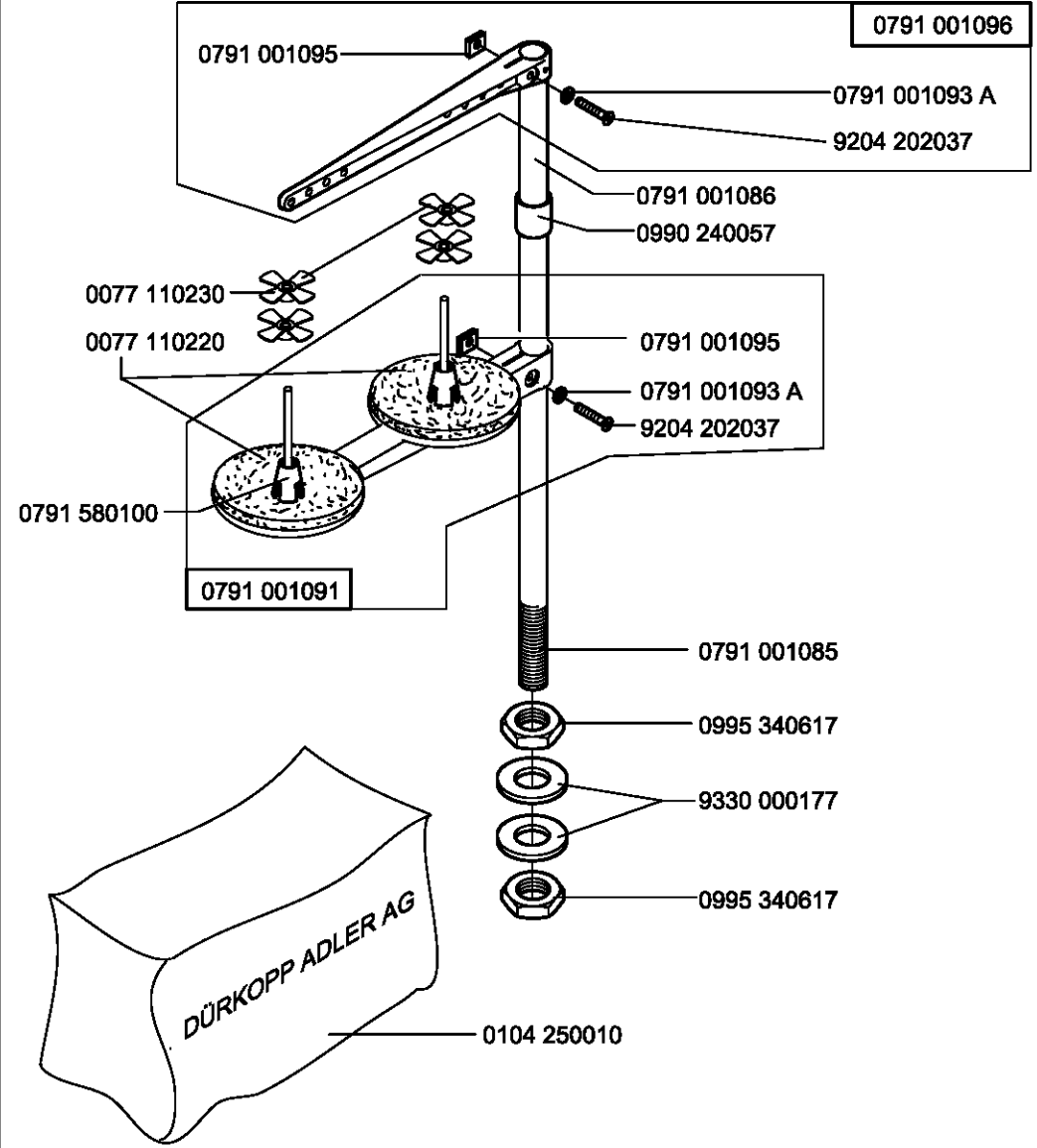

0791 001095

0791 001096

0791 001093 A

9204 202037

0791 001086

0990 240057

0077 110230

0077 110220

0791 001095

0791 001093 A

9204 202037

0791 580100

0791 001091

0791 001085

0995 340617

9330 000177

0995 340617

DÜRKOPP ADLER AG

0104 250010

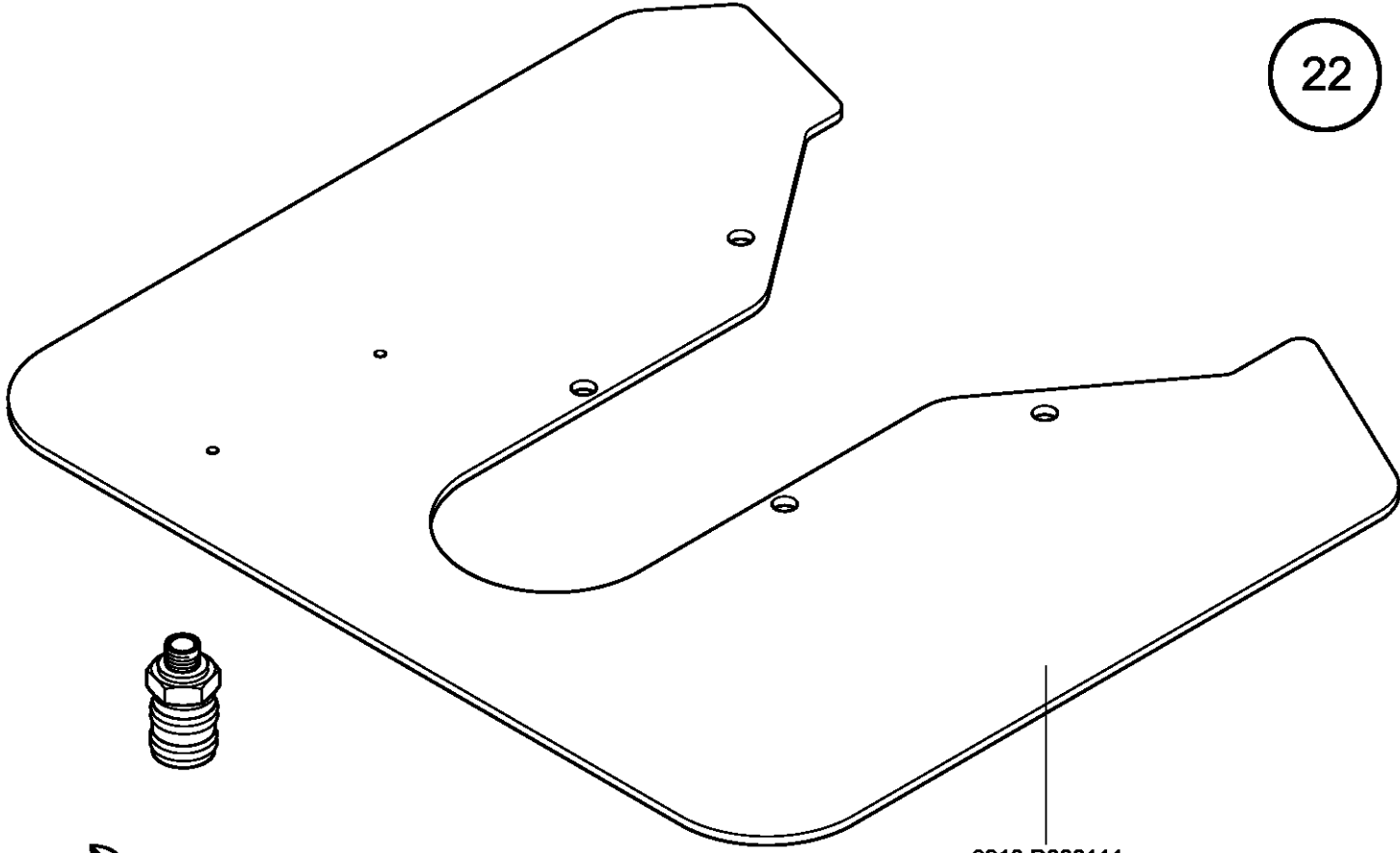
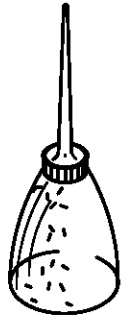
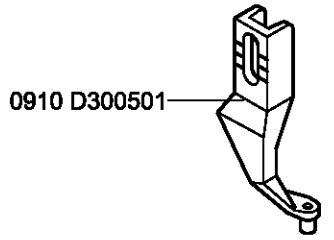
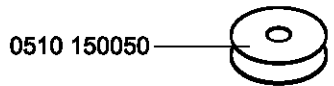

0910 D300111

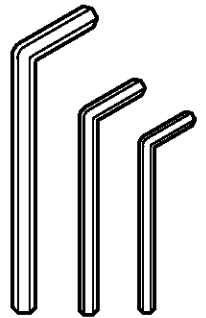
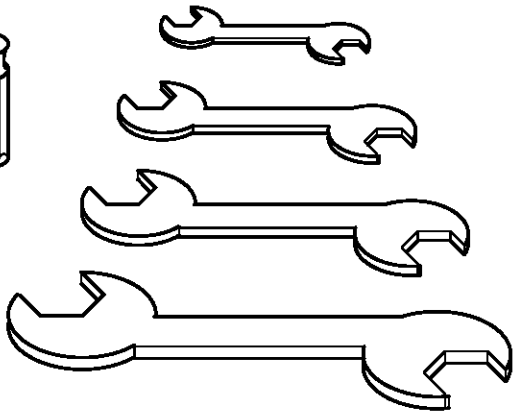
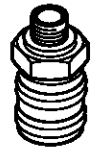
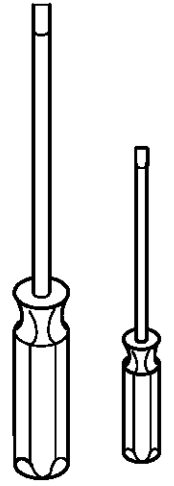
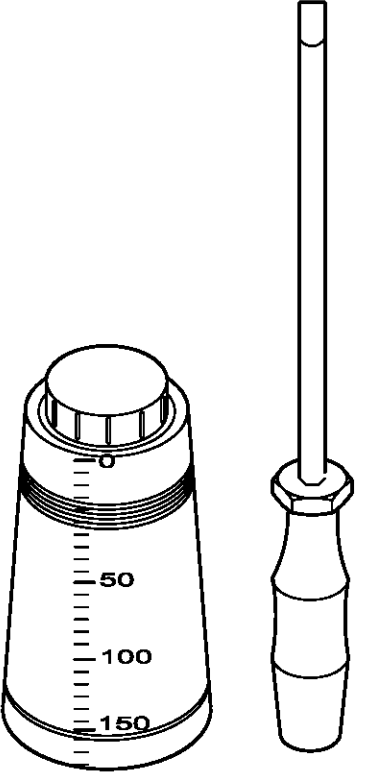

Teilenummer Part No	Seite Page	Bezeichnung /Description	
		D	GB
0196 000220	7	FADENFÜHRUNG	L-SHAPED THREAD GUIDE
0367 110340	7	FADENANZ. ROLLE	THREAD GUIDE WHEEL
0367 110360	7	SCHEIBE	DISC
0467 110220	7	SPANNUNGSSCHEIBE	TENSION DISC
0510 5100123	7	VULKULANSCHLEIBE	RUBBER SHEET
0510 5100124	7	VULKULANSCHLEIBE	RUBBER SHEET
0510 5100703	15	ZYL. SCHR.	SCREW
0580 110250	7	FADENFÜHRUNG	THREAD GUIDE PLATE
0667 110180	7	BOLZEN	THREAD TENSION ROD
0667 110200	7	FADENANZ. FEDER	THREAD TAKE-UP SPRING
0667 110250	7	KAPSEL	HOUSING
0667 110380	7	SPANNHÜLSE	CLAMP RING
0667 115250	7	ZWISCHENSCHLEIBE	GUIDE PLATE
0667 115520	7	SCHEIBE 22X6,5	RUBBER SHEET
0667 115850	7	FEDER	SPRING
0767 110342	7	ANSATZBUCHSE	THREAD TENSION ROD
0767 110360	7	ANSCHLAG	STOPPER PLATE
0910 000030	5	KABELHALTER	INSTALLING BASE
0910 000031	5	KABELFÜHRUNG	RUBBER SHEET
0910 100100	2	KLOBEN	SENSOR INSTALLING BASE
0910 100110	2	180° SCHEIBE	MAIN SHAFT SLIT PLATE
0910 100140	7	HALTER	SWITCH INSTALLING PLATE
0910 100150	7	SPANNUNGSPLATTE	THREAD GUIDE BRACKET
0910 100160	7	FADENREGULATOR	THREAD GUIDE
0910 100193	7	HALTER	STROKEMAGNET INSTALLING BASE
0910 100200	3	GABEL	AIR CYLINDER LINK SHAFT
0910 100210	3	WINKEL	AIR CYLINDER INSTALLING BASE
0910 100230	5	WINKEL	SOLENOID VALVE INSTALLING BASE
0910 100240	7	ABDECKUNG	MANTLE
0910 100250	7	HALTER	SWITCH INSTALLING BASE
0910 100260	5	WINKEL	PCB INSTALLING BASE
0910 100270	7	BLATTFEDER	SPRING
0910 100280	7	DISTANZMUTTER	LINK NUT
0910 100290	7	FADENHEBELSCHUTZ	BALANCE COVER
0910 100300	15	FILZ	OIL FELT
0910 417514	20	KLAMMERPLATTE GLATT	LOWER PLATE BLANK/FEEDING
0910 417524	20	KLAMMERPLATTE	LOWER PLATE BLANK/FEEDING
0910 417533	20	PLEXIGLASPLATTE	PLASTIC BLANK PLATE ASM.
0910 505 40-15	7	DRUCKSCHEIBE	PUSH PLATE
0910 5100517	14	FÜHRUNGSSCHRAUBE	SCREW
0910 5100913	8	STICHPLATTE Ø 1,6MM	NEEDLE HOLE GUIDE
0910 9100101	7	ABDECKUNG	SWITCH COVER
0910 9100102	14	ABDECKUNG	COVER
0910 9100103	14	ÖLWANNE	OIL PAN
0910 9100104	14	ABDECKUNG	BED COVER,RIGHT
0910 9100105	14	ABDECKUNG	BED COVER,LEFT
0910 9100106	14	ARMDECKEL	TOP COVER
0910 91001071	14	OBERARM	MACHINE ARM
0910 91001072	14	UNTERARM	MACHINE BED
0910 9100108	14	RÄNDELSCHRAUBE	NUT
0910 9100109	14	STELLSCHRAUBE	SCREW
0910 9100301	1	ZUGSTANGE	NEEDLE BAR CRANK ROD
0910 9100402	4	BLECH	PRESSER PLATE SHEET
0910 91005060	3	FUSS	INTERMEDIATE PRESSER,AIR
0910 9101001	8	PLATTE	NEEDLE PLATE

Teilenummer Part No	Seite Page	Bezeichnung /Description	
		D	GB
0910 9101002	8	STICHPLATTE Ø 2,2MM	NEEDLE HOLE GUIDE
0910 91012	11	KLAMMER K	CLOTH FEED MECHANISM
0910 9101201	11	BOLZEN	PLUNGER PIN
0910 9101202	11	BOLZEN	SHAFT BLOCK SHAFT
0910 9101203	11	SCHEIBE	WASHER
0910 9101204	11	FÜHRUNGSPLATTE	WORK CLAMP FOOT PLATE
0910 9101205	11	DRUCKPLATTE	WORK CLAMP FOOT PLATE COVER
0910 9101206	11	HEBEL RECHTS	CLOTH PRESSER HOOK,RIGHT
0910 9101207	11	HEBEL LINKS	CLOTH PRESSER HOOK,LEFT
0910 9101208	11	STELLRING	THRUST COLLAR
0910 9101209	11	HEBEL RECHTS	SUPPORT LINK,RIGHT
0910 9101210	11	HEBEL LINKS	SUPPORT LINK,LEFT
0910 9101211	11	BOLZEN	SLIDER SHAFT
0910 9101212	11	LASCHE	LINK STOPPER
0910 9101213	11	LASCHE	FEED BRACKET LINK
0910 9101214	11	HEBEL RECHTS	FEED BRACKET UPPER LINK,RIGHT
0910 9101215	11	HEBEL LINKS	FEED BRACKET UPPER LINK,LEFT
0910 9101216	11	STIFT	FIXATION PIN
0910 9101221	11	SCHEIBE	WASHER
0910 9101301	15	LASCHE	OIL TUBE HOLDER
0910 910201	2	ARMWELLE	MAIN SHAFT
0910 910401	4	PLATTE	PRESSER PLATE
0910 910501	3	FINGERSCHUTZ	FINGER GUARD
0910 910503	3	RÄNDELMUTTER	NUT
0910 910504	3	REGULIERUNGSSCHRAUBE	PRESSER SPRING REGULATOR
0910 910E101	7	KABELSCHUTZ	RUBBER PLUG
0910 910E101	14	STOPFEN	RUBBER PLUG
0910 910E102	5	DISTANZBOLZEN	HINGE SCREW
0910 CQ2A25-15DCM	3	ZYLINDER (FÜSSENHEBEN)	AIR CYLINDER
0910 CQ2A25-25DCM	4	ZYLINDER	AIR CYLINDER
0910 D2801140	14	EINSATZ	OIL MANAGEMENT ASM.
0910 D280824	10	SCHEIBE	WASHER
0910 D300110	14	DICHTUNG	COVER GASKET
0910 D300111	22	NÄHGUTAUFPLAGE	NEEDLE PLATE SUPPORT COVER
0910 D300115	14	ÖLROHR	OIL REMOVING TUBE
0910 D300202	2	GLEITLAGER	BUSHING,FRONT
0910 D300203	2	STELLRING	INTERMEDIATE CAM STOPPER
0910 D300204	2	HUBEXENTER	INTERMEDIATE CAM
0910 D300205	2	GLEITLAGER	BUSHING,INNER
0910 D300206	2	STELLRING	THRUST COLLAR
0910 D300301	1	GELENKHEBEL	THREAD TAKE-UP CRANK
0910 D300302	1	NADELSTANGE	NEEDLE BAR
0910 D300304	1	FADENFÜHRUNG	THREAD GUIDE
0910 D3003050	1	FADENHEBEL	THREAD TAKE-UP LEVER COMPL.
0910 D300306	1	EXENTERBOLZEN	NEEDLE BAR CRANK
0910 D300401	4	BUCHSE	BUSHING,FRONT
0910 D300402	4	BOLZEN	SHAFT
0910 D300403	4	HEBEL	LINK
0910 D300408	4	HEBEL	LINK
0910 D300409	4	LASCHE	LINK
0910 D300410	4	HEBEL	LINK
0910 D300411	4	LASCHE	LINK
0910 D300412	4	SCHEIBE	PRESSER PLATE SHEET WASHER
0910 D300413	4	ZYL. SCHR.	SCREW
0910 D300414	4	SCHEIBE	THRUST WASHER

Teilenummer Part No	Seite Page	Bezeichnung /Description	
		D	GB
0910 D300417	4	FEDER	SPRING
0910 D300418	4	ZYL.STIFT	CONTROL PIN
0910 D300419	4	FÜHRUNGSBLECH	SHAFT GUIDE
0910 D300420	12	STELLRING	THRUST COLLAR
0910 D300420	3	STELLRING	THRUST COLLAR ASM.
0910 D300420	4	STELLRING	THRUST COLLAR ASM.
0910 D300421	3	BOLZEN	LINK FULCRUM SHAFT
0910 D300421	4	BOLZEN	LINK FULCRUM SHAFT
0910 D300422	4	DISTANZSCHEIBE	WASHER
0910 D3004230	4	ANSCHLAG	STOPPER RUBBER
0910 D300424	4	BOLZEN	LINK FULCRUM SHAFT
0910 D300501	22	FUSS	INTERMEDIATE PRESSER
0910 D300503	3	STOFFDRÜCKERSTANGE	PRESSER BAR
0910 D300504	3	STOFFDRÜCKERSTANGEN	BUSHING,LOWER
0910 D300505	3	WINKEL	GUIDE BRACKET SUPPORT PLATE
0910 D300506	3	DRUCKSTANGE	PRESSER GUIDE BAR
0910 D300507	3	FEDER	SPRING
0910 D3005100	3	HEBEL	LINK COMPL.
0910 D300511	3	MUTTER	NUT
0910 D300512	3	STELLRING	THRUST COLLAR ASM.
0910 D300513	3	ZUGSTANGE	ROD
0910 D300514	3	MUTTER	ADJUSTING NUT
0910 D300515	3	ANSATZSCHRAUBE	STEP-SCREW
0910 D300516	3	HEBEL	DRIVE ARM COMPL.
0910 D300517	3	ZUGSTANGE	LINK
0910 D300518	3	HEBEL	LINK COMPL.
0910 D300519	3	HEBEL	LINK
0910 D300520	3	HEBEL	LINK
0910 D300523	3	BOLZEN	PIN
0910 D300525	3	DISTANZSCHEIBE	WASHER
0910 D300526	3	DISTANZSCHEIBE	WASHER
0910 D300527	3	ANSATZSCHRAUBE	HINGE SCREW
0910 D300528	3	DISTANZSCHEIBE	WASHER
0910 D300529	3	ZYL. SCHR.	SCREW
0910 D300601	6	GEHÄUSE	SHUTTLE
0910 D300602	12	ZYL. SCHR.	SCREW
0910 D300803	12	ZYL. SCHR.	SCREW
0910 D300901	10	ZUGSTANGE	CONNECTING BAR
0910 D301103	12	PASSSCHRAUBE	HINGE STUD
0910 D301104	12	HALTER	CROSSFEED SENSOR FIXED BASE
0910 D3011070	12	GETRIEBEPLATTE	MOTOR BASE COMPL.
0910 D301108	12	STELLRING	THRUST COLLAR ASM.
0910 D301109	12	DICHTUNG	RUBBER WASHER
0910 D301110	12	BOLZEN	CROSSFEED FULCRUM SHAFT
0910 D301111	12	PASSSCHRAUBE	HINGE SCREW
0910 D301112	12	KLOBEN	LENGTHWISE FEED ARM
0910 D301113	12	SCHALTFAHNE Y	LENGTHWISE SENSOR SLIT
0910 D301116	12	ZYL. SCHR.	SCREW
0910 D301117	12	ABDECKUNG	CLOTH FEEDSUPPORT PLATE
0910 D301202	11	ANSATZBOLZEN	FEED REGULATOR CONNECTING
0910 D301204	11	FEDER RECHTS	SPRING,RIGHT
0910 D301205	11	FEDER LINKS	SPRING ,LEFT
0910 D301206	11	KLAMMERPLATTE	LOWER PLATE
0910 D301207	11	TRÄGER	CLOTH FEED BRACKET
0910 D301210	11	HALTER	WORK CLAMP FOOT

Teilenummer Part No	Seite Page	Bezeichnung /Description	
		D	GB
0910 D301211	11	RAHMEN	FEEDING FRAME
0910 D301218	11	FEDER	SPRING
0910 D301222	11	GLEITSTÜCK	SLIDER
0910 D301301	15	ÖLFILZHALTER	OIL WICK PRESSER
0910 D301302	15	ÖLFILZHALTER	OIL WICK PRESSER
0910 D301303	15	ÖLFILZ	BALANCE LUBRICATING
0910 D301304	15	ÖLFILZHALTER	OIL FELT PRESSER
0910 D301305	15	ÖLFILZ	OIL FELT
0910 D301307	15	ÖLDOCHT	OIL WICK
0910 D301308	15	ÖLFILZ	OIL FELT
0910 D301701	12	TRÄGER	CLOTH FEED PLATE
0910 D301702	12	SCHALTFAHNE X	CROSSFEED SENSOR SLIT
0910 D301703	12	FÜHRUNGSPLATTE	CLOTH FEED SUPPORT PLATE
0910 D301704	12	ZAHNSTANGE	LENGTHWISE FEED SHAFT
0910 D301705	12	ZAHNRAD	CROSSFEED GEAR
0910 D301706	12	X- HEBEL	CROSSFEED ARM
0910 D301708	12	FÜHRUNGSPLATTE	CROSSFEED SLIDE PLATE
0910 D302201	2	KURBEL	COUNTER WEIGHT
0910 D8.07-21	11	SCHEIBE	WASHER
0910 D8.08-13	12	GLEITSTEIN	SQUARE BLOCK
0910 D8.13-15	15	KLEMME	OIL WICK PRESSER
0910 EE-SX674	12	LICHTSCHRANKE	SENSOR
0910 GB5846	1	NADELLAGER	NEEDLE BUSHING
0910 GB894.1-86	3	SICHERUNGSRING	C-RING
0910 K410404	3	KLOBEN	PRESSER BAR GUIDE BRACKET
0910 NSK6000NNZR	12	KUGELLAGER	BEARING
0910 NTN6900ZZ	12	KUGELLAGER	BEARING
0910 TLP1204	12	LICHTSCHRANKE	SENSOR
0910GB74-85	12	STELLRING	SCREW
171922R	5	VENTIELLEISTE	SOLENOID VALVE
9800 150009	2	MOTOR (NÄHANTRIEB)	MAIN MOTOR
9815 710100	2	SCHALTER	SENSOR
9815 740001	7	FADENWÄCHTER	THREAD MONITOR
9820 110020	7	MAGNET	STROKEMAGNET THREAD CLAMP
9820 110021	7	MAGNET	MAGNET
9840 104011	9	SCHUTZHÜLSE	RECEPTACLE
9840 111003	9	FLACHST.H.-BAND	CAP
9850 001060 CN	5	LEITERPLATTE K	PCB
9850 910001	5	LEITERPLATTE K	PCB
9880 910001	7	SCHALTER K	SWITCH SAFETY STOP
FPL4-M5	3	WI. VERSCHRAUBUNG	HOSE ELBOW

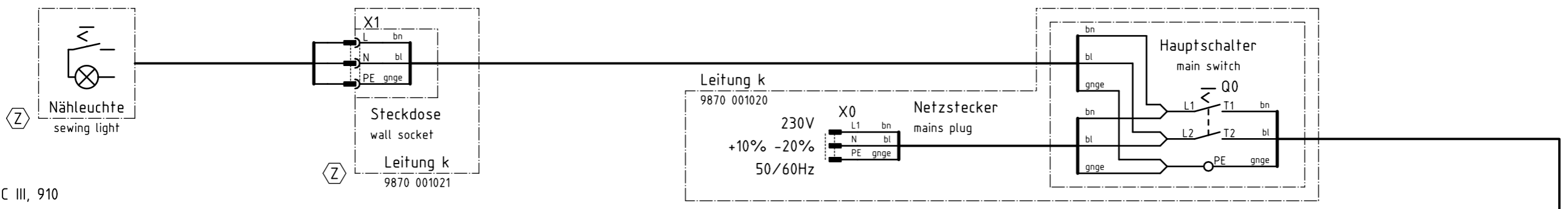

Steuerung k DAC III, 910
9850 910010

control DAC III, 910

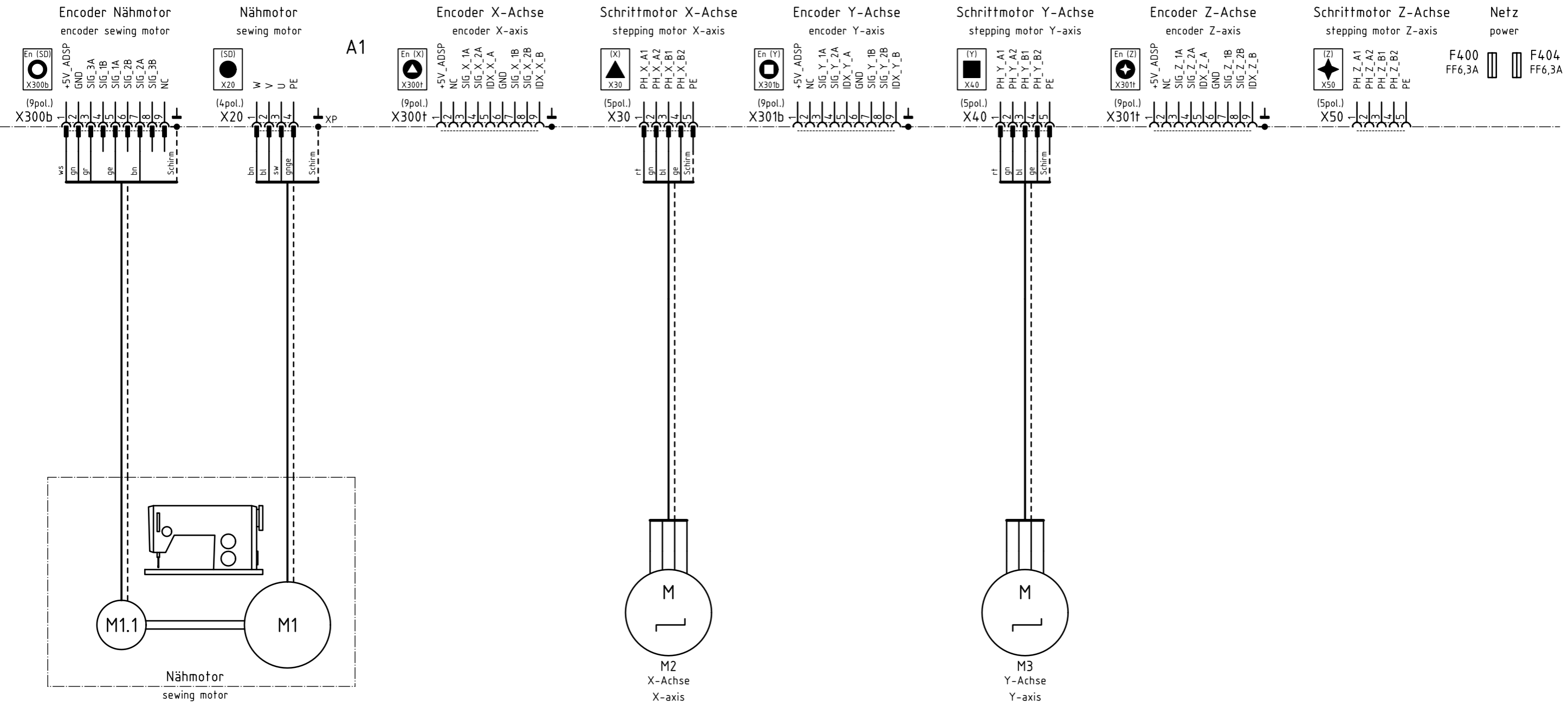

Zusatzeinrichtung
optional equipment

c			Datum	24.04.06
b			Bearb.	Cz
a			Gepr.	
	Anderung	Datum	Name	Norm

DÜRKOOP
ADLER AG
Bielefeld

Teilefamilie	910
Freigabe	0040 / 06

Zuleitung, Steuerung, Nähtrieb, Schrittmotore
lead, control, sewing drive, stepping motors

Bauschaltplan
9890 910001 B

A1

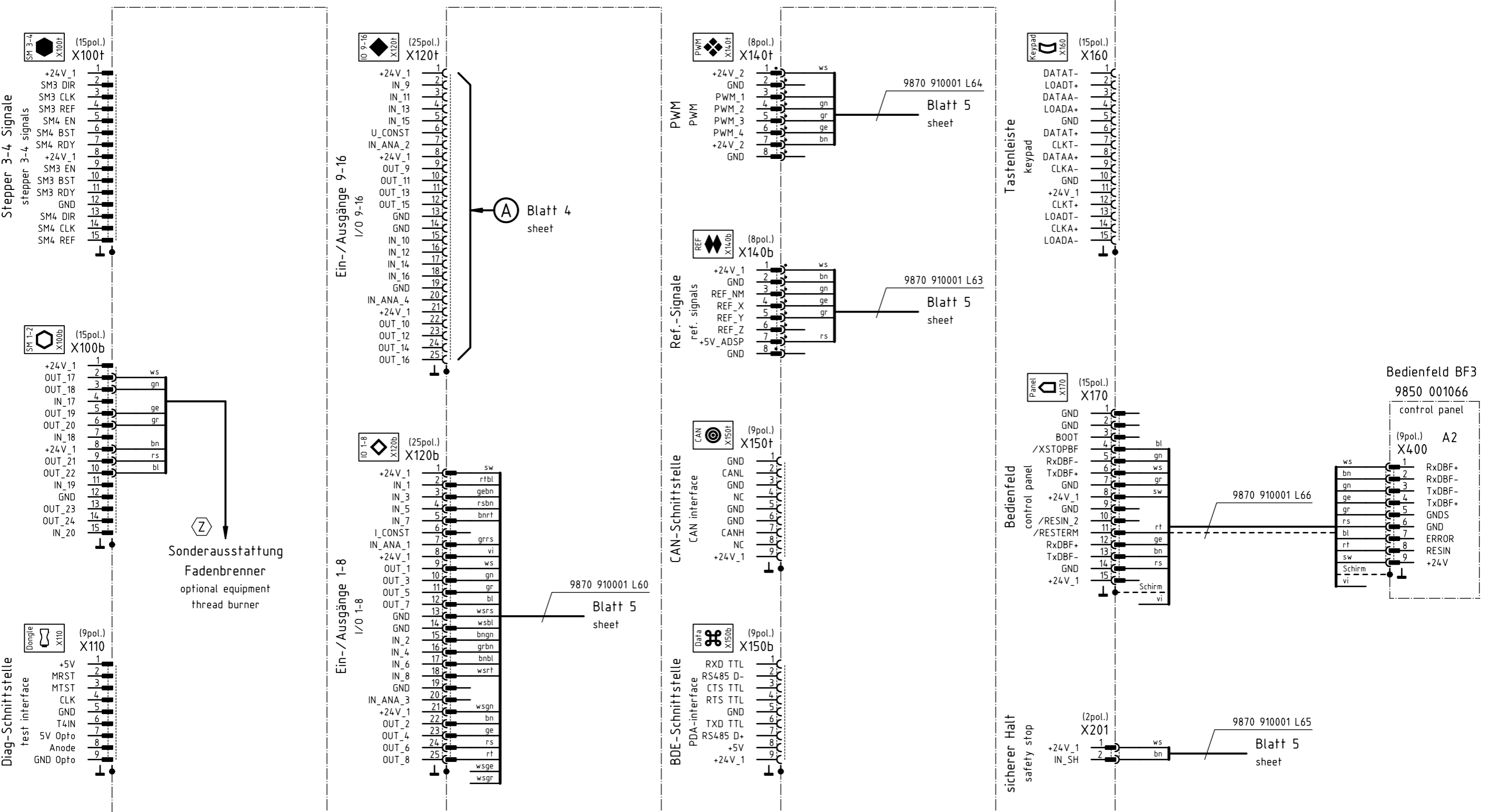

Kodierung coding
 Zusatzeinrichtung optional equipment

c			Datum	24.04.06
b			Bearb.	Cz
a			Gepr.	
	Änderung	Datum	Name	Norm



Teilefamilie
 910
 Freigabe
 0040 / 06

910
 I/O, PWM, Ref.-Signale, Bedienfeld
 I/O, PWM, ref. signals, control panel

Bauschaltplan
 9890 910001 B

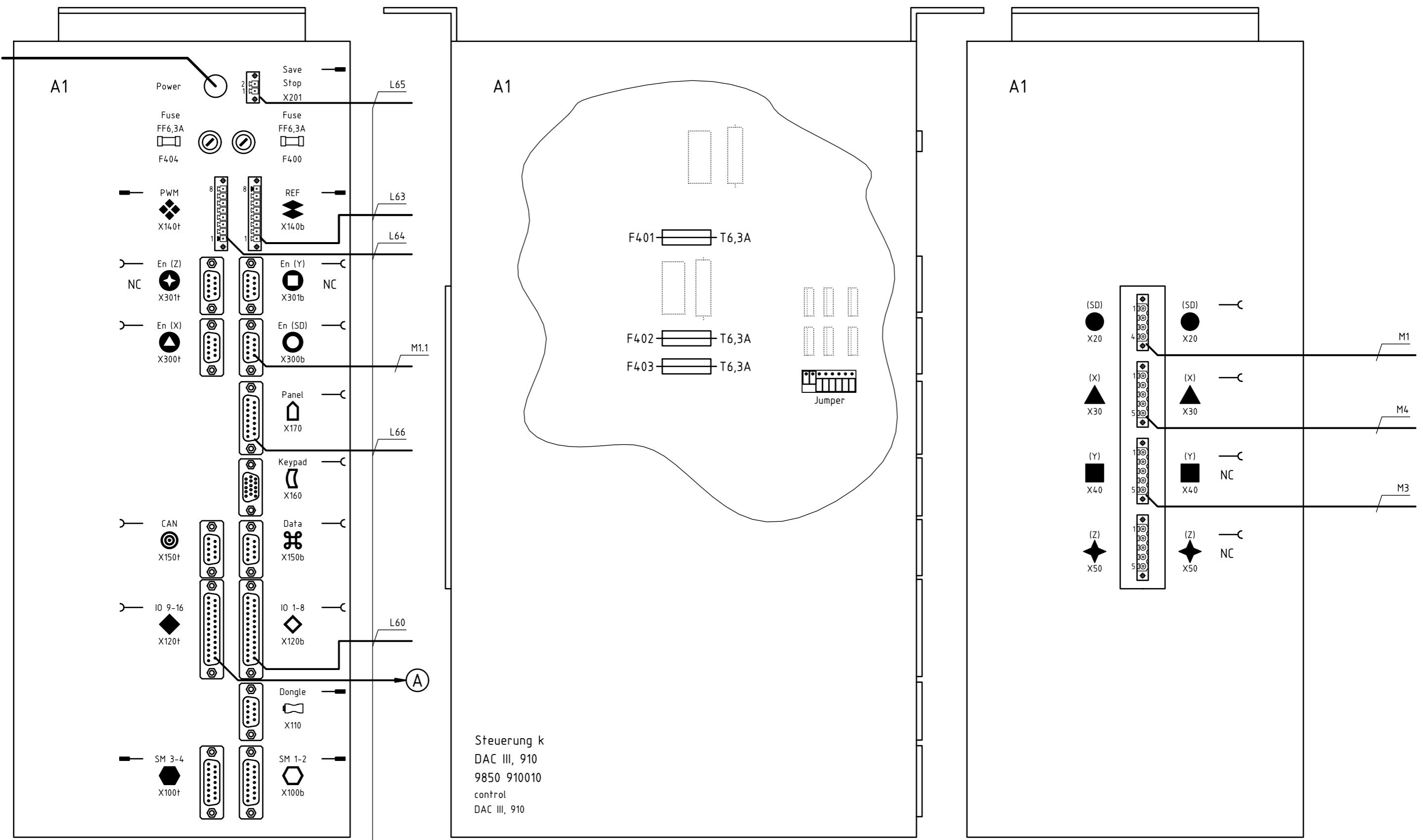

Steuerung k
 DAC III, 910
 9850 910010
 control
 DAC III, 910

9870 910001 Lxx

c			Datum	24.04.06	DÜRKOPP ADLER AG Bielefeld	Teilefamilie	910 Steuerung, Anschlußplan control, connection diagram	Bauschaltplan 9890 910001 B	Blatt 3 / 7
b			Bearb.	Cz		Freigabe			
a			Gepr.			0040 / 06			
	Änderung	Datum	Name	Norm					

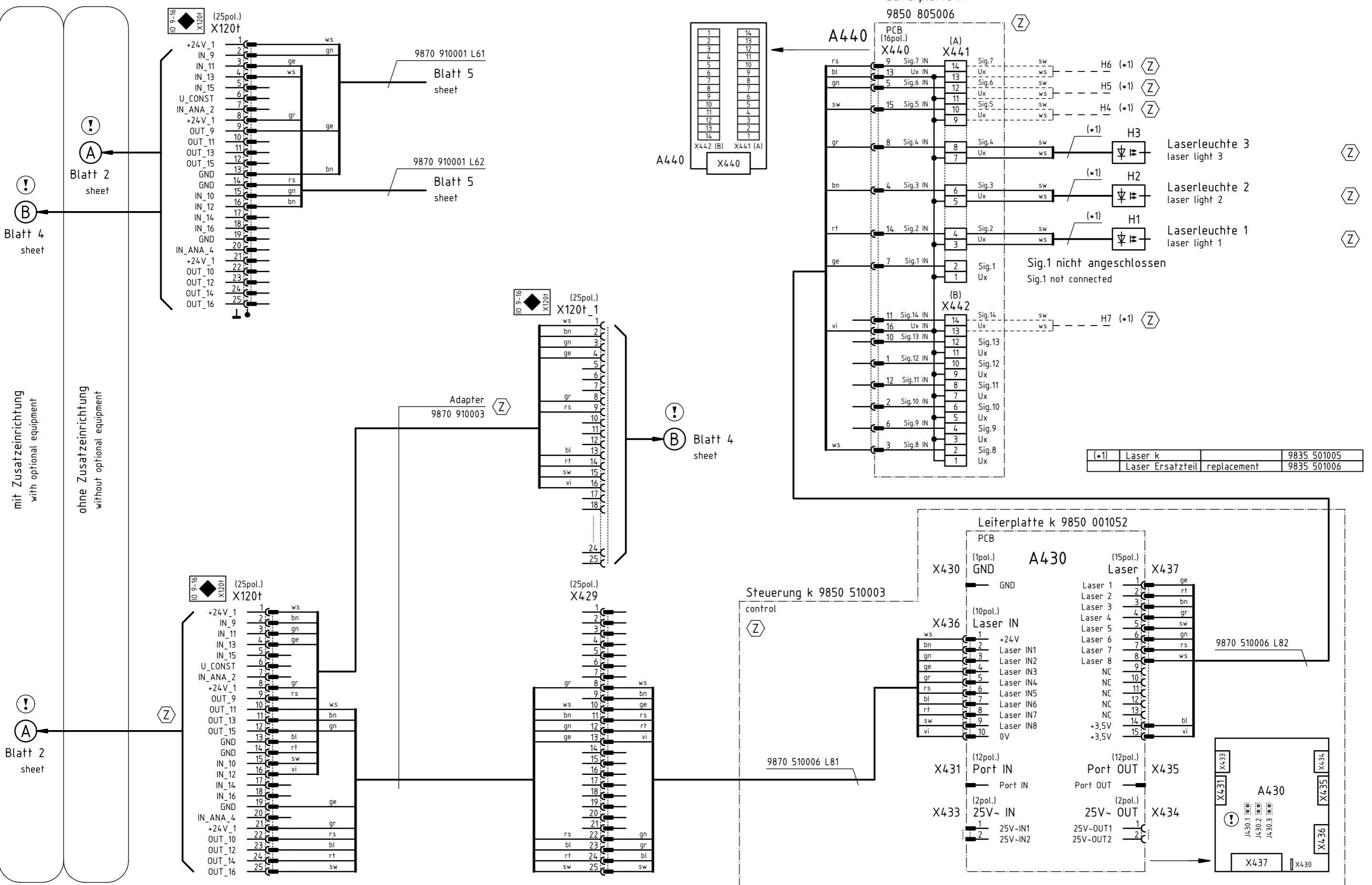

mit Zusatzeinrichtung
with optional equipment

ohne Zusatzeinrichtung
without optional equipment

(*)	Laser k		9835 501005
	Laser Ersatzteil	replacement	9835 501006

⚠ Konfiguration beachten!
observe the configuration!

Ⓩ Zusatzeinrichtung
optional equipment

c			Datum	24.04.06
b			Bearb.	Cz
a			Gepr.	
	Anderung	Datum	Name	Norm

DÜRKOPP ADLER AG Bielefeld

Teilefamilie: 910 Laserleuchten laser lights

Freigabe: 0040 / 06

A5

Leiterplatte k 9850 910001 CN
PCB

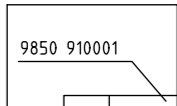

Blatt 6
sheet

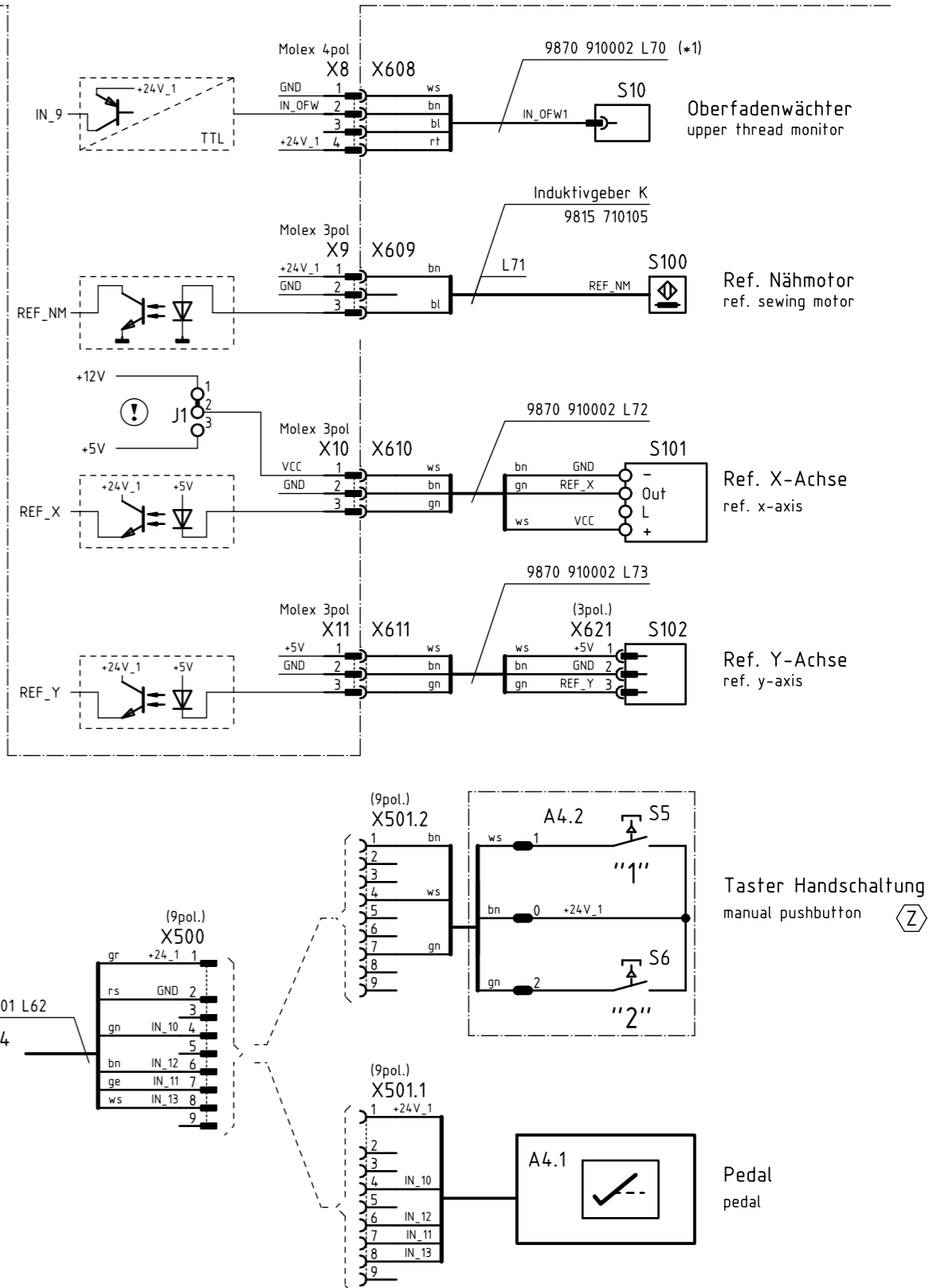
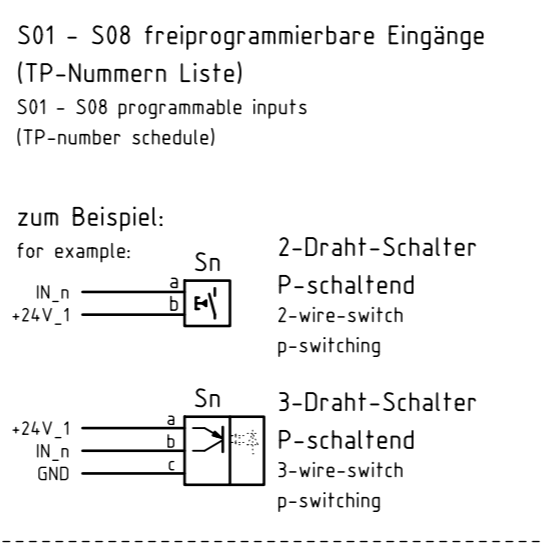
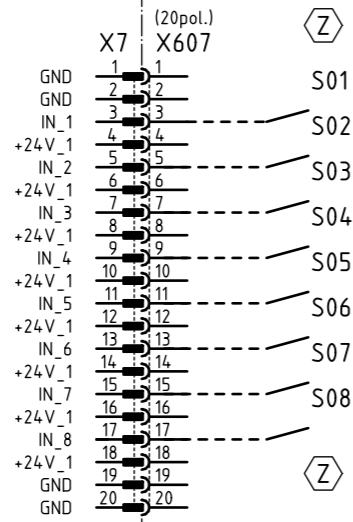
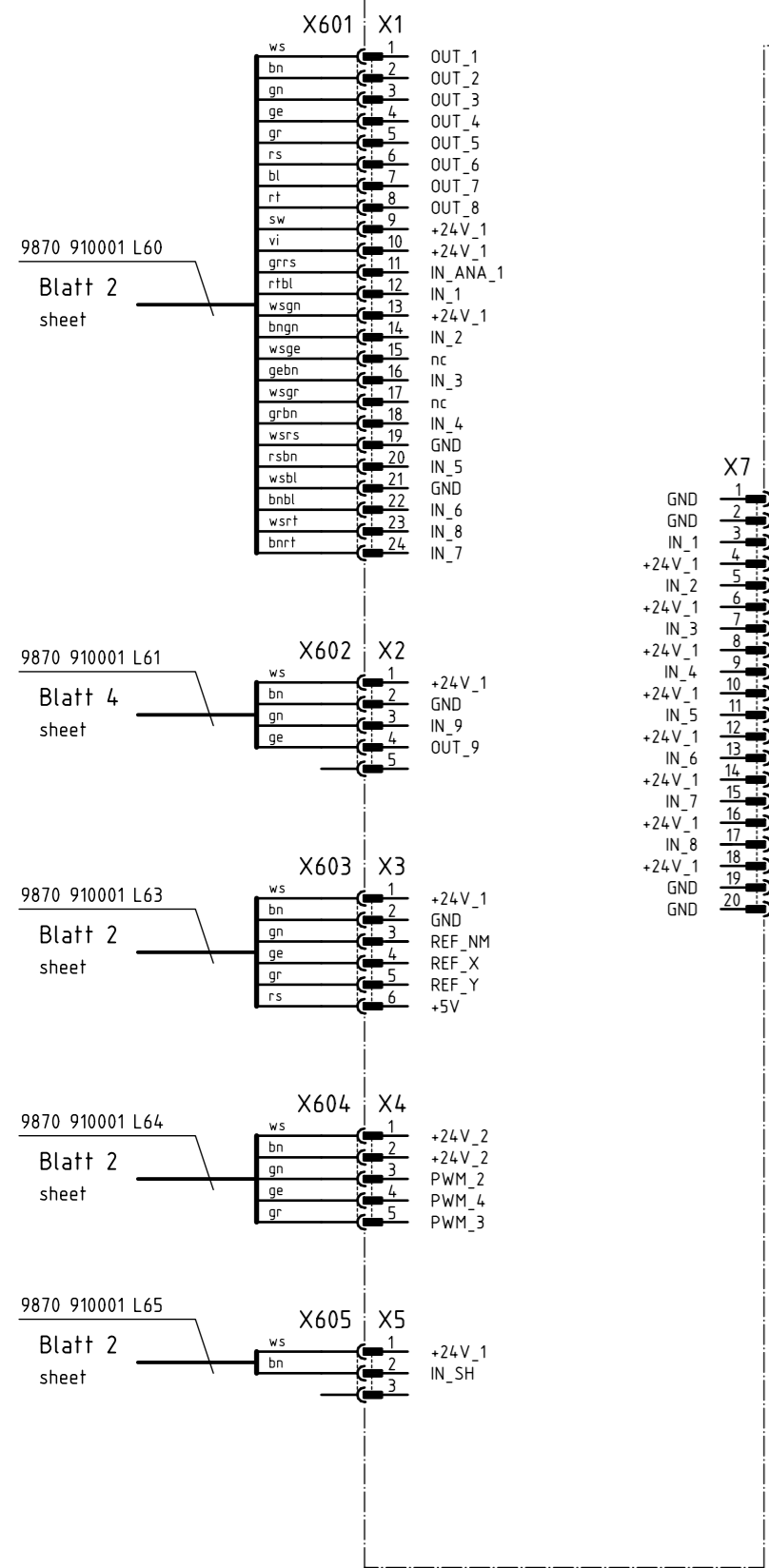

9870 910001 L60
Blatt 2
sheet

9870 910001 L61
Blatt 4
sheet

9870 910001 L63
Blatt 2
sheet

9870 910001 L64
Blatt 2
sheet

9870 910001 L65
Blatt 2
sheet

9870 910001 L62
Blatt 4
sheet

(*1) Ersatzleitung replacement cable 9870 745104 L220

⚠ Konfiguration beachten!
observe the configuration!

Ⓩ Zusatzeinrichtung
optional equipment

c			Datum	24.04.06
b			Bearb.	Cz
a			Gepr.	
	Änderung	Datum	Name	Norm



Teilfamilie
Freigabe
0040 / 06

910
Eingänge
inputs

Bauschaltplan
9890 910001 B

Blatt
5 / 7

Leiterplatte k 9850 910001 CN

PCB

9850 910001

A5

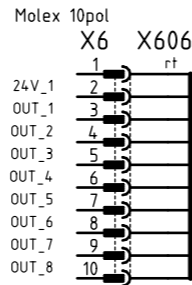
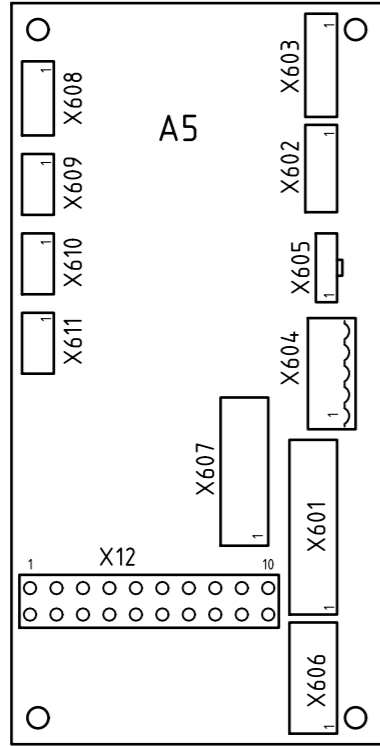

Flachbandleitung k
9840 610008

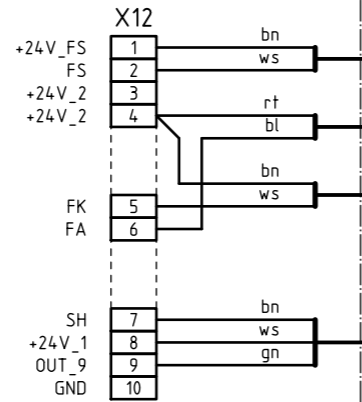

L77

Schalter k 9880 910001

switch

A7

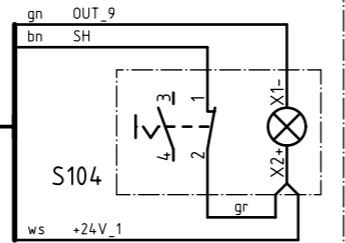

sicherer Halt
safety stop

Leiterplatte k
9850 001060

PCB

(10pol.)
X623

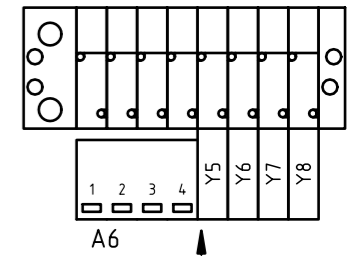
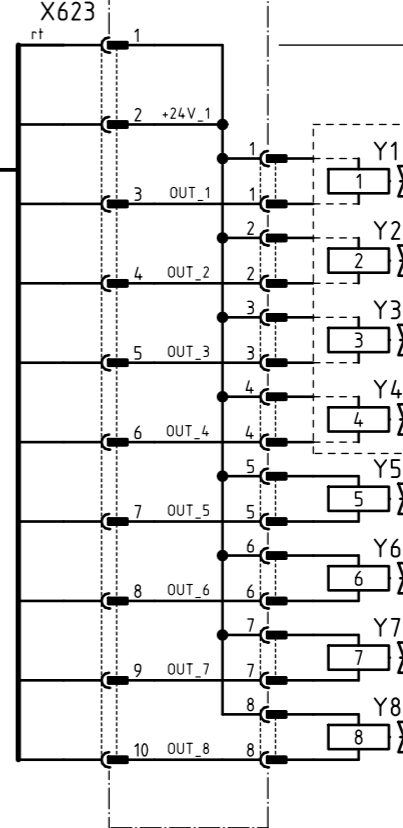

Z

Z

Nadelkühlung
needle cooler

Klammerplatte 2
clamping plate 2

Klammerplatte 1
clamping plate 1

Nähfuß lüften
lift the presser foot

Fadenspannung 1
thread tension 1

Fadenspannung 2
thread tension 2

Faden abschneiden
cut the thread

Fadenklemme
thread clamp

9870 910002 L74

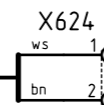

Y102.1

Y102.2

Y103

Y104

L75

L76

Z Zusatzeinrichtung
optional equipment

c			Datum	24.04.06
b			Bearb.	Cz
a			Gepr.	
	Änderung	Datum	Name	Norm



DÜRKOPP
ADLER AG
Bielefeld

Teilefamilie	910
Freigabe	0040 / 06

910
Ein-/Ausgänge
inputs/outputs

Bauschaltplan
9890 910001 B

Kurzzeichen	Teilenummer	Benennung	denomination	Typ	Bemerkung
A1	9850 910010	Steuerung k	control	DAC III, 910	Variante 1
A2	9850 001066	Bedienfeld BF3	control panel	BF3	
A4.1	9800 330012	Pedal	pedal		Ext. Betaetigung EFKA
A4.2	9880 910004	Taster k	pushbutton switch		Handtaster
A5	9850 910001 CN	Leiterplatte k	PCB		
A6	9850 001060	Leiterplatte k	PCB		8 Magnetventile
A7	9880 910001	Leuchtdruckschalter	illuminated pushbutton switch		sicherer Halt
F400; F404	9825 810107	Sicherung	fuse	FF6,3A	5x20mm
F401 - 403	9825 810417	Sicherung	fuse	T6,3A	5x20mm
H1 - H7	9835 501005	Laser k	laser		1000mm
H7 - H7	9835 501006	Ersatzlaser	replacement laser		170mm
M1	9800 150009	Nähtrieb o.S.	sewing motor	QE3760	ohne Steuerung
M2	0510 510BA25-X	Schrittmotor	step motor		X-Achse
M3	0510 510BA25-Y	Schrittmotor	step motor		Y-Achse
Q0	9815 580008	Netzschalter	mains switch		rot-gelb
S10	9815 740001	Oberfadenwächter	thread monitor	IDS/D BTR	
S10	9870 745104 L220	Kabel für Oberfadenwächter	connector cable for thread monitor		
S100	9815 710105	Induktivgeber k	approximate switch	NBB1,5-8GM40-Z0	Ref. Nähmotor
S101	0910 TLP1204	Lichtschranke k	light barrier		Ref. X-Achse
S102	0910 EE-SX674	Lichtschranke k	light barrier		Ref. Y-Achse
X0	9825 190104	Netzstecker	mains plug	Schuko (DE)	(on request/auf Wunsch)
X1	9825 190103	Steckdose	wall socket	Schuko (DE)	
Y102.1	9820 110021	Hubmagnet	Lifting solenoid		Fadenspannung 1
Y102.1	9820 110021	Hubmagnet	Lifting solenoid		Fadenspannung 2
Y103	0510 5100816Z	Hubmagnet	Lifting solenoid		Faden abschneiden
Y104	9820 110020	Hubmagnet	Lifting solenoid		Fadenklemme

9890 910001 B / 7

KL.910 :
Ansicht von oben
top view

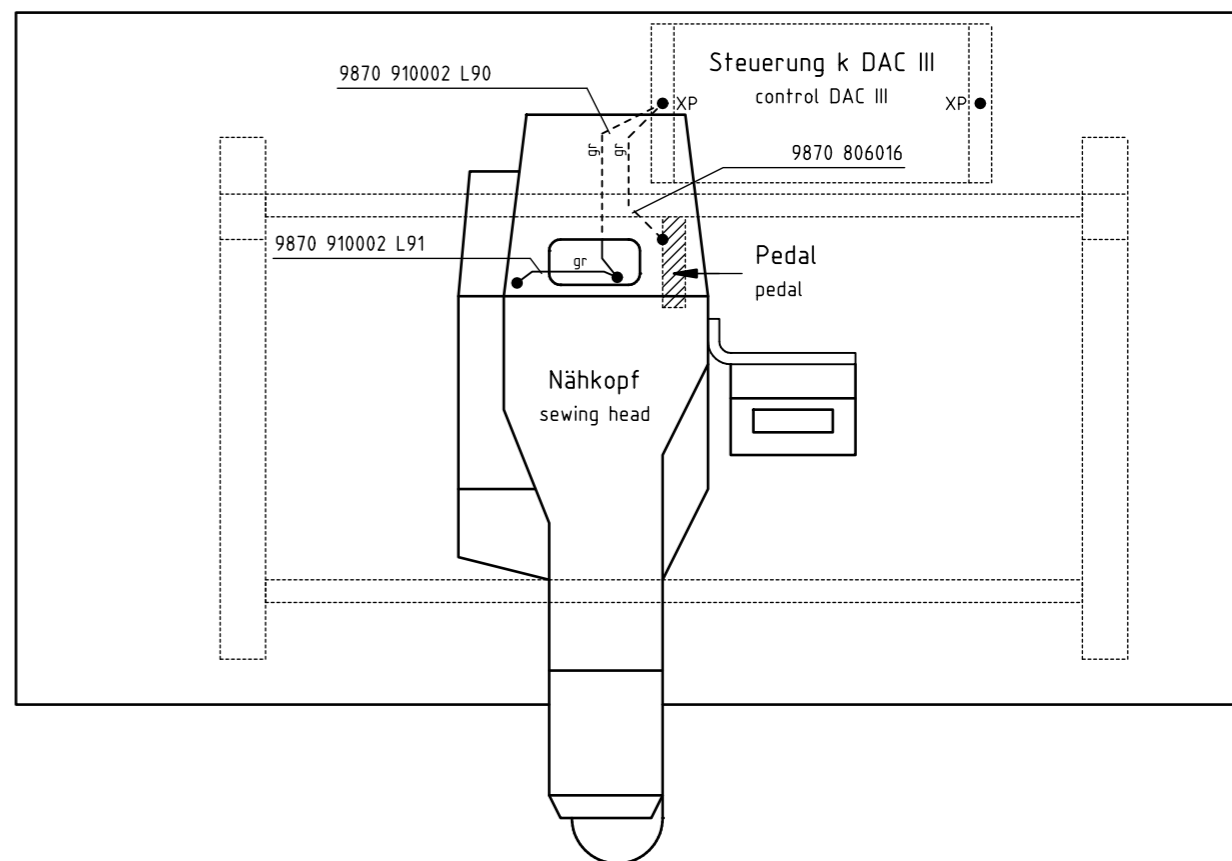

c			Datum	24.04.06
b			Bearb.	Cz
a			Gepr.	
	Anderung	Datum	Name	Norm



DÜRKOPP
ADLER AG
Bielefeld

Teilfamilie	910
Freigabe	0040 / 06

910
 Teileliste, Potentialausgleich
 parts list, operational bondings

Bauschaltplan
 9890 910001 B