

Teileliste und Naehinrichtungen Parts List and Sewing Equipment

867

DÜRKOPP ADLER AG

Postfach 17 03 51, D-33703 Bielefeld • Potsdamer Str. 190, D-33719 Bielefeld
Telefon +49 (0) 5 21/ 9 25-00 • Telefax +49 (0) 5 21/ 9 25 24 35 • www.duerkopp-adler.com

Ausgabe / Edition: 01/2010	Aenderungsindex Rev. index: 04.0	Printed in Czech Republic	Teile-Nr./Part.-No.: 0791 867801
--------------------------------------	--	---------------------------	--

Alle Rechte vorbehalten.
Eigentum der Dürkopp Adler AG und urheberrechtlich geschützt. Jede, auch auszugsweise
Wiederverwendung dieser Inhalte ist ohne vorheriges schriftliches Einverständnis der Dürkopp Adler AG
verboten.

All rights reserved.

Property of Dürkopp Adler AG and copyrighted. Reproduction or publication of the content in any manner,
even in extracts, without prior written permission of Dürkopp Adler AG, is prohibited.

Copyright © Dürkopp Adler AG - 2010

Inhaltsverzeichnis	Tafel / Table	Contents
Armwelle	1	Upper shaft
Armwelle-Langarm		Upper shaft-long arm
Armwelle-schaltbare nadelstangen		Upper shaft-needle bar rocking mechanism
Antrieb Arm- und Unterwelle, Rastkupplung,	2	Upper and bottom shaft drive, Safety clutch,
Antrieb Arm- und Unterwelle-Langarm		Upper and bottom shaft drive -long arm
Fadenhebel	3	Thread lever
Fadenhebel-schaltbare nadelstangen	4	Thread lever-needle bar rocking mechanism
Antrieb Nadeltransport, Antrieb Nadeltransport-Langarm	5	Needle feed drive, Needle feed drive-long arm
Alternierender Obertransport, Fussfuehrung	6	Alternating foot top feed, Foot guide
Alternierender Obertransport-Langarm, Fussfuehrung	7	Alternating foot top feed-long arm, Foot guide
Antrieb Untertransport, Antrieb Untertransport-Langarm	8	Bottom feed drive, Bottom feed drive-long arm
Transporteurhub	9	Bottom feed
Transporteurhub Null	10	Bottom feed zero
Fusslueftung, Fusslueftung-Langarm	11	Presser foot lift hand lever, Presser foot lift hand lever -long arm
Fusslueftung mech.	12	Presser foot lift knee lever
Fusslueftung pneu.	13	Presser foot lift pneumatic
Hubverstellung, Hubverstellung-Langarm	14	Skipping foot lift pneumatic, Skipping foot lift pneumatic -long arm
Grosser Greifer mit Spule	15	Large hook with bobbin
Grosser Greifer	16	Large hook
Uebergrosser Greifer mit Spule	17	Oversized hook with bobbin
Uebergrosser Greifer	18	Oversized hook
Uebergrosser Greifer mit Spule KFA	19	Oversized hook with bobbin short thread trimmer
Grosser Greifer mit Spule KFA	20	Large hook with bobbin short thread trimmer
Greiferlager rechts	21	Hook case right
Greiferlager links	22	Hook case left
Fadenabschneider, Fadenabschneider-Langarm	23	Thread trimmer, Thread trimmer-long arm
Kurz-Fadenabschneider	24	Short thread trimmer
Spuler	25	Winder
Spannungsplatte Einnadel mech.	26	Tension plate 1 needle mech.
Spannungsplatte Einnadel pneu., Spannungsplatte Einnadel pneu. -Langarm	27	Tension plate 1 needle pneu., Tension plate 1 needle pneu. -long arm
Spannungsplatte Einnadel pneu.	28	Tension plate 1 needle, pneu.
Spannungsplatte Zweinadel mech.	29	Tension plate 2 needles mech.

Inhaltsverzeichnis	Tafel / Table	Contents
Spannungsplatte Zweinadel pneu., Spannungsplatte Zweinadel pneu. -Langarm	30	Tension plate 2 needles pneu., Tension plate 2 needles pneu. -long arm
Spannungsplatte Zweinadel pneu.	31	Tension plate 2 needles pneu.
Stichverstellung 1 Stichlaenge	32	Stitch adjustment 1 stitch length
Stichverstellung 2 Stichlaengen, Stichverkuerzung	33	Stitch adjustment 2 stitch lengths, Stitch reduction
Verriegelung mech., pneu., Stichverkuerzung	34	Backtacking mech., pneu., Stitch reduction
Verriegelung mech.-Langarm	35	Backtacking mech.-long arm
Magnetventileinheit, Taster, Taster-Langarm	36	Solenoid valve unit, Push-buttons, Push-buttons-long arm
Magnetventileinheit, Taster, Taster-Langarm	37	Solenoid valve unit, Push-buttons, Push-buttons-long arm
Magnetventileinheit, Taster	38	Solenoid valve unit, Push-buttons
Magnetventileinheit, Taster	39	Solenoid valve unit, Push-buttons
Zentralschmierung, Zentralschmierung-Langarm	40	Central lubrication, Central lubrication-long arm
Zentralschmierung	41	Central lubrication
Arm, Fadenfuehrung, Integr. Diodennaehleuchte	42	Arm, Thread guide, Sewing light LEDs
Arm, Integr. Diodennaehleuchte- Kantenschneider	43	Arm, Sewing light LEDs-trimmer
Arm, Magnetventileinheit, Integr. Diodennaehleuchte - schaltbare nadelstangen	44	Arm, Solenoid valve unit, Sewing light LEDs -needle bar rocking mechanism
Arm, Fadenfuehrung-Langarm	45	Arm, Thread guide-long arm
Armdeckel ECO	46	Arm cover ECO
Armdeckel ECO-Langarm	47	Arm cover ECO-long arm
Armdeckel CLASSIC	48	Arm cover CLASSIC
Armdeckel CLASSIC-Langarm	49	Arm cover CLASSIC-long arm
Armdeckel CLASSIC mit Blockierung	50	Arm cover CLASSIC with blocking
Grundplatte	51	Bed plate
Grundplatte-Langarm	52	Bed plate-long arm
Einfassen	53	Facing
Kantenschneider	54, 55	Trimmer
Naehleuchte Halogen	56	Sewing lamp halogen
Naehantrieb, Bedienfeld	57	Motor, Control panel
Teilesatz fuer FIR 1147-F752.3 und FIR 1148-F752.3	58	Part set for FIR 1147-F752.3 and FIR 1148-F752.3
Teilesatz fuer EFKA VD552KV/6F82DA	59	Part set for EFKA VD552KV/6F82DA
Teilesatz fuer EFKA DC1600/DA82GA	60	Part set for EFKA DC1600/DA82GA
Teilesatz fuer EFKA DC1550/DA321G	61	Part set for EFKA DC1550/DA321G
Teilesatz fuer EFKA DC 1500	62	Part set for EFKA DC 1500
Gestell	63	Stand
Gestell-Langarm	64	Stand-long arm

867

Inhaltsverzeichnis	Tafel / Table	Contents
Wartungseinheit	65	Maintenance unit
Beipack	66, 67	Accessories
Beipack-Langarm	66, 68	Accessories-long arm
Restfadenwaechter	69	Thread monitor
Elektropneum. Nadelkuehlung von oben, unten	70	Electropneum. needle cooling upper, lower
Integr. Diodennaehleuchte	71	Sewing light LEDs
Netzteil K		Power supply K
Kantenanschlag		Edge guide
Kantenanschlag		Edge guide
Lineal auf Schieber		Edge guide
Rollenanschlag		Roller stop
Nahtmittenfuehrung schwenkbar		Swivelling seam centre guide
Nahtmittenfuehrung		Seam centre guide
Nahtmittenfuehrung von vorne pneum. schaltbar	72	Electropneum. seam centre guide
Eindiodennaehleuchte	73	Sewing lamp LED
Fuesschenlueftung pneu., Fuesschenlueftung mech.	74	Sewing foot lift pneu., Manual foot lift pedal
Reflexlichtschrinke	75	Light barrier
Stichlaengeblockierung	76	Stitch length blocking
Drehzahlregler		Speed regulator
Index		Index
Stichplattenschieber		Slide
Befestigungsteile fuer Naehleinrichtung		Fastening parts for sewing equipment
Naehleinrichtungen		Sewing equipment
Bauschaltplan		Wiring diagram
Pneu. Geraeteplan		Pneumatic circuit plan

867



Einnadel-Maschine
single needle machine



Zweinadel-Maschine
two needle machine

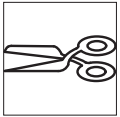

mit Fadenabschneider
with thread trimmer

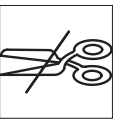

ohne Fadenabschneider
without thread trimmer

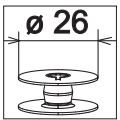

Ø 26
grosser Greifer
large hook

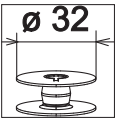

Ø 32
uebergrosser Greifer (XXL)
oversized hook (XXL)

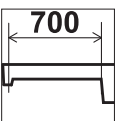

700
Langarm/long arm



Kurz-Fadenabschneider
short thread trimmer



ohne Kurz-Fadenabschneider
without short thread trimmer

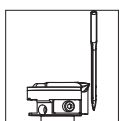

Greifer links der Nadel
hook left of the needle

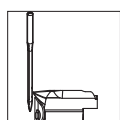

Greifer rechts der Nadel
hook right of the needle

Teilleiste und Naheinrichtungen
Parts List and Sewing Equipment

867



mit Kantenabschneider
with edge trimming

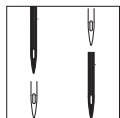

Schaltbare Nadelstangen
needle bar rocking mechanism



kleben/stick

N nicht einzeln lieferbar/not available as separate part

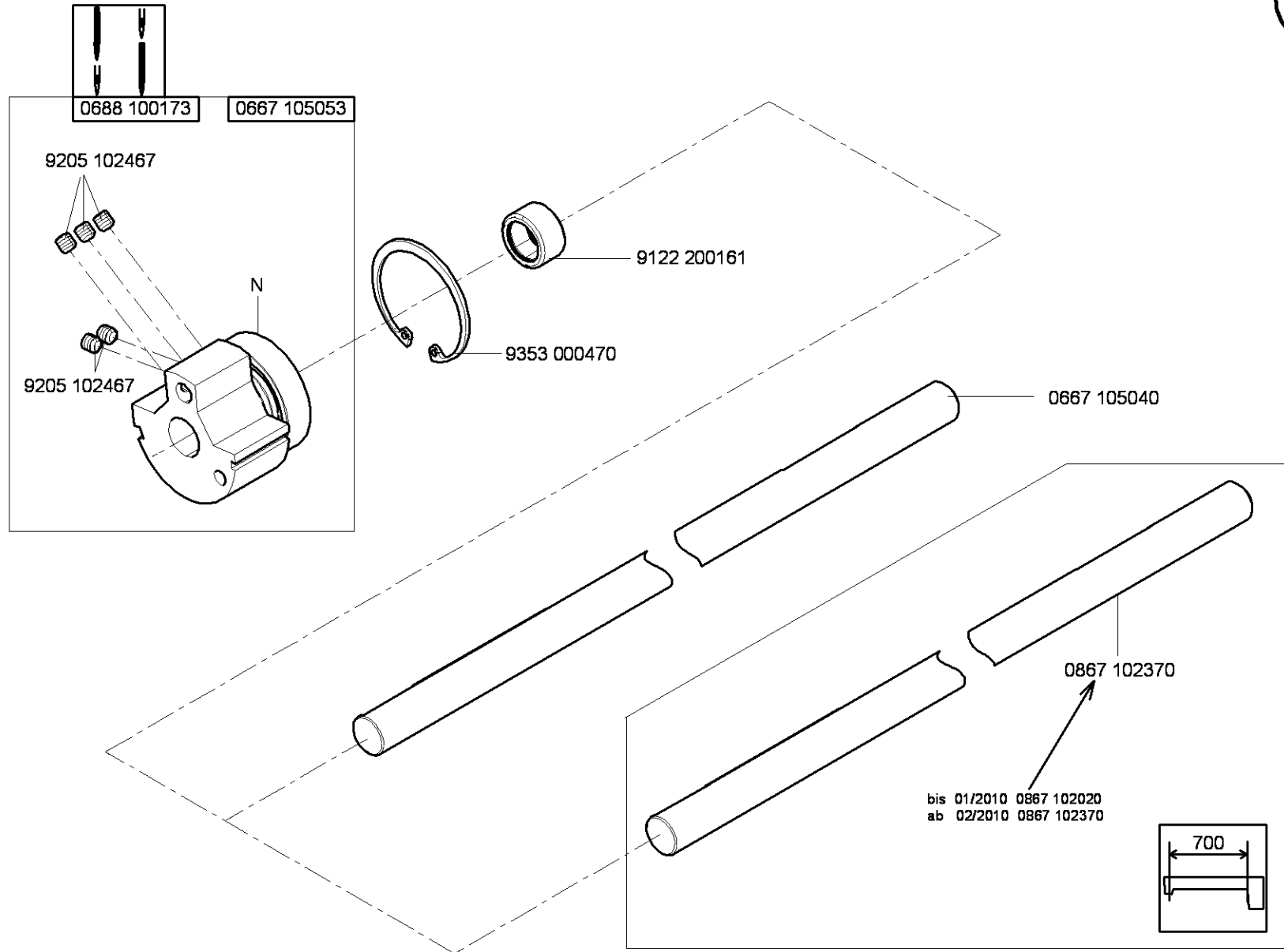

N - nicht als Einzelteil lieferbar
not available as separate part

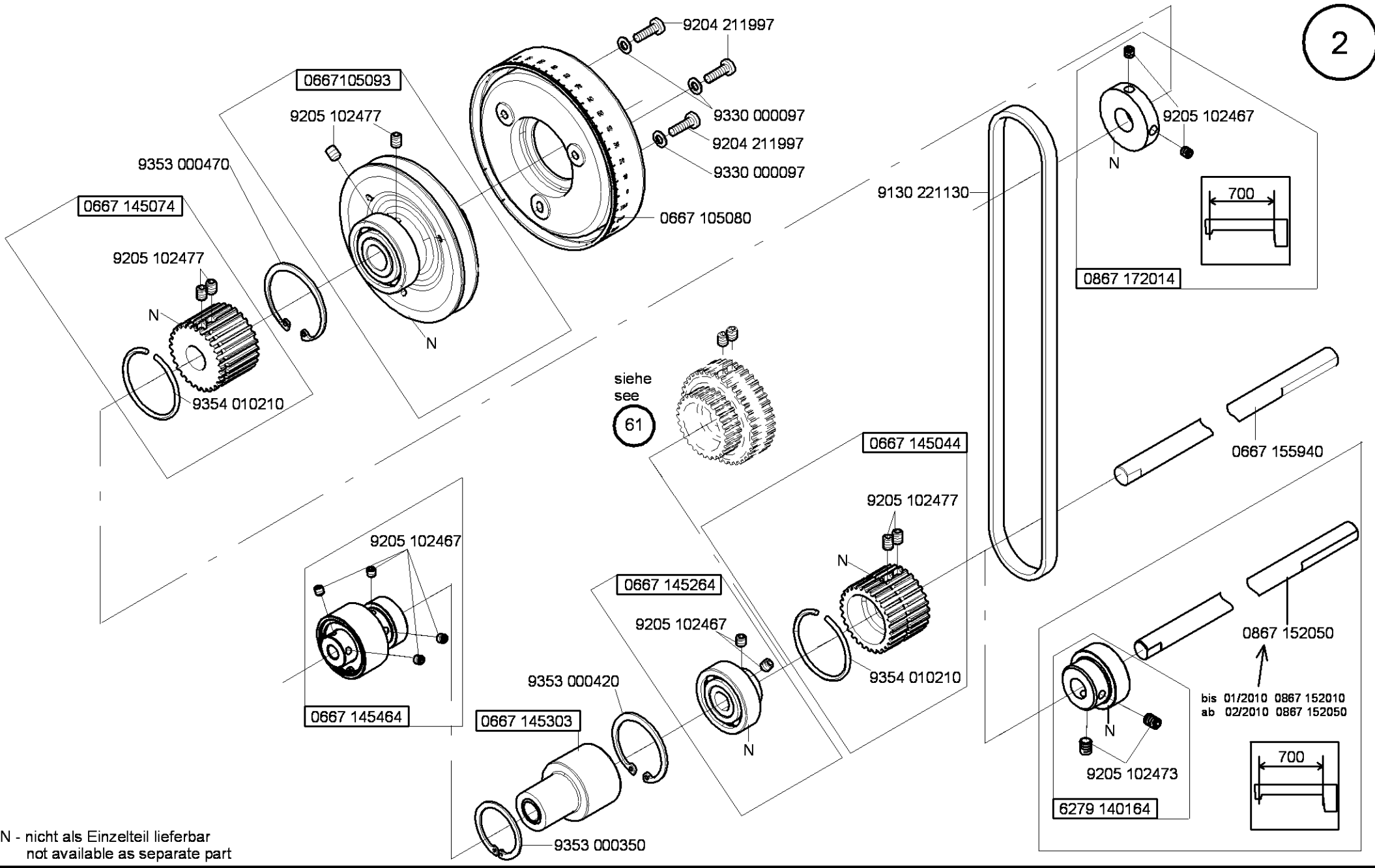

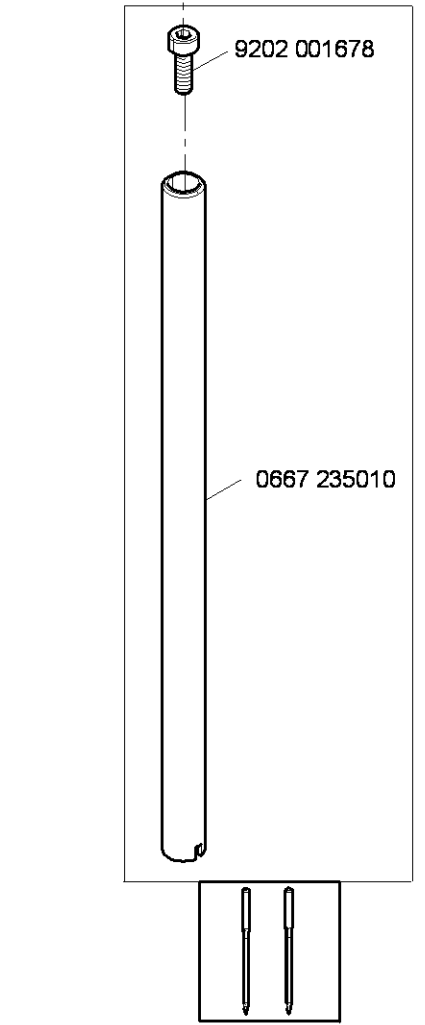
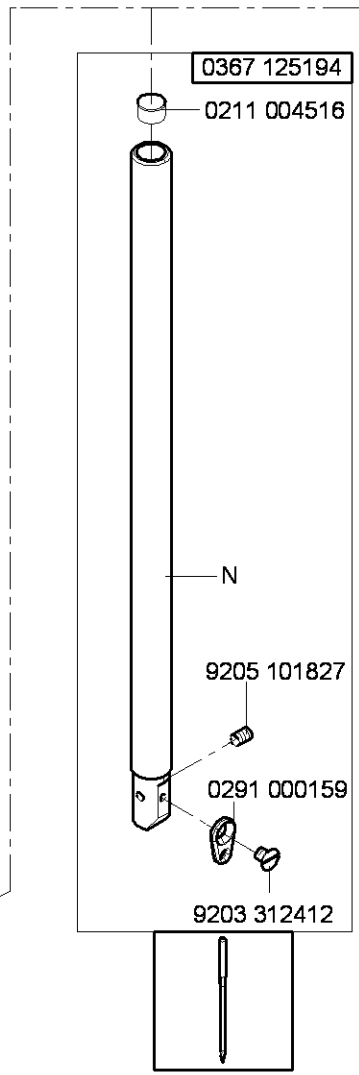
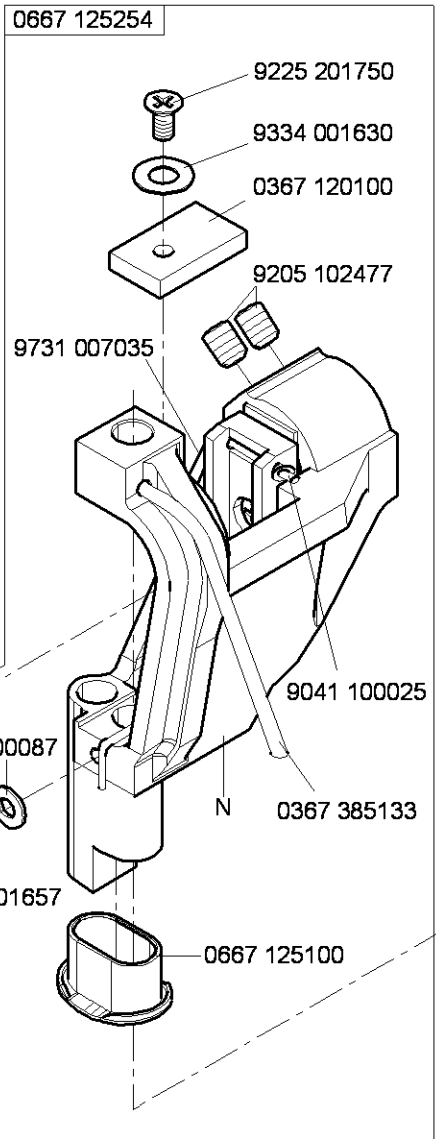
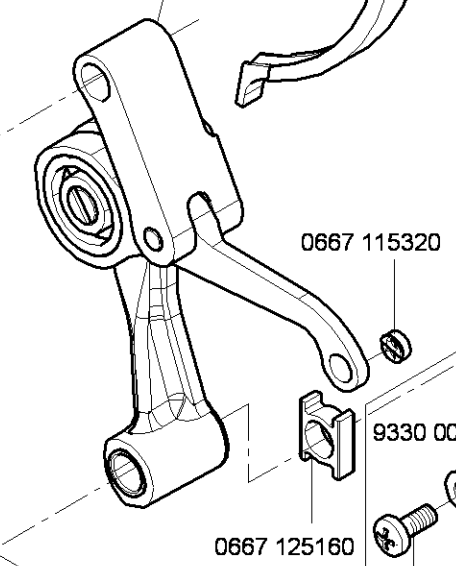
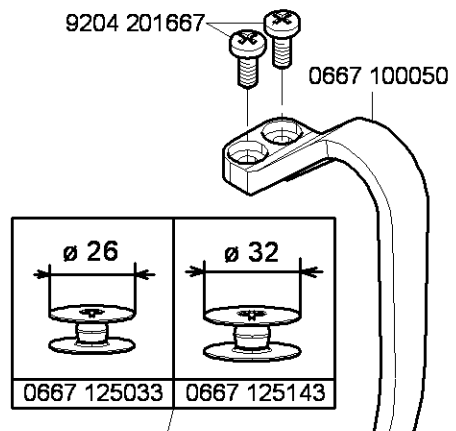
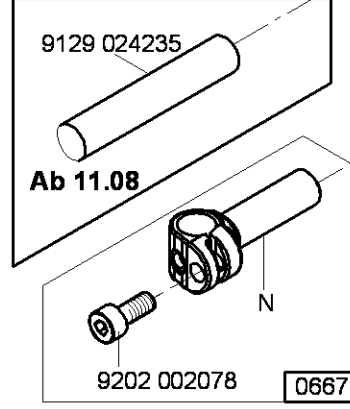
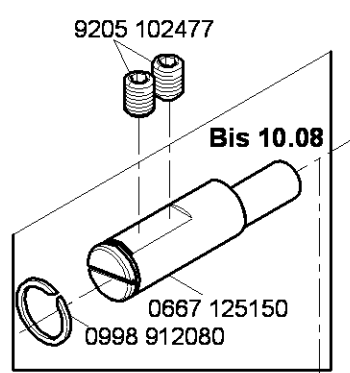
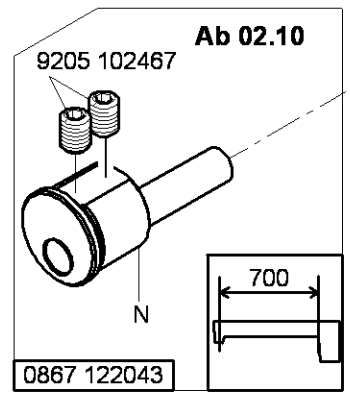

N - nicht als Einzelteil lieferbar
not available as separate part

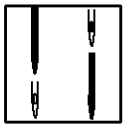

CI. 867 -490322

9204 201667 0667 100050

0867 120024

4

9205 102477

9129 024235

0867 120533

0867 120280

0867 120043

0867 120043

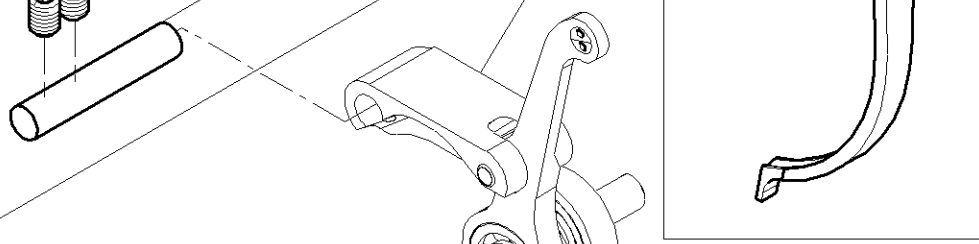

9203 001827

9330 000027

N

N

N

N

0867 120423

9203 001827

0867 120140

0867 120100

0867 120370

0867 120350

0867 120420

9354 400800

9202 001658

0867 120170

0688 380163

0867 120410

9205 102477

9205 102188

9205 102188

9334 001640

9217 300507

0867 120300

9217 300507

0867 120400

0867 120020

0867 120130

0867 120110

0902 004102

0867 120380

0867 120340

9202 001658

9301 100991

9301 101001

0867 120070

0867 120090

0867 120160

0867 120360

9301 100941

0867 120080

9203 001807

9203 001807

0867 120120

0867 120150

0867 120440

9202 001658

N - nicht als Einzelteil lieferbar
not available as separate part

bis 01/2010 0867 122010
ab 02/2010 0867 122060

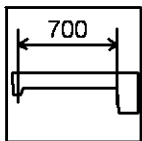

0867122060

0667 125060

9126 300201

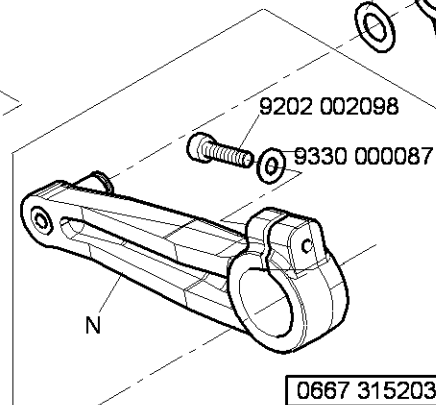

9202 002098

9330 000087

0667 315203

N

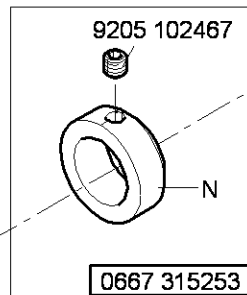

9205 102467

0667 315253

N

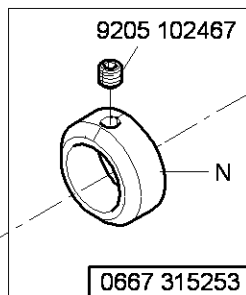

9205 102467

0667 315253

N

0667 315243

9122 322200

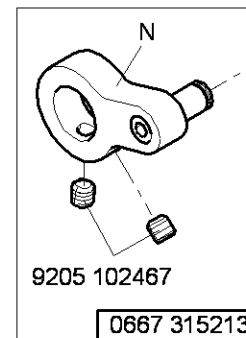

9205 102467

0667 315213

N

9334 001640

9357 000090

0667 315223

9357 000090

9334 001640

N - nicht als Einzelteil lieferbar
not available as separate part

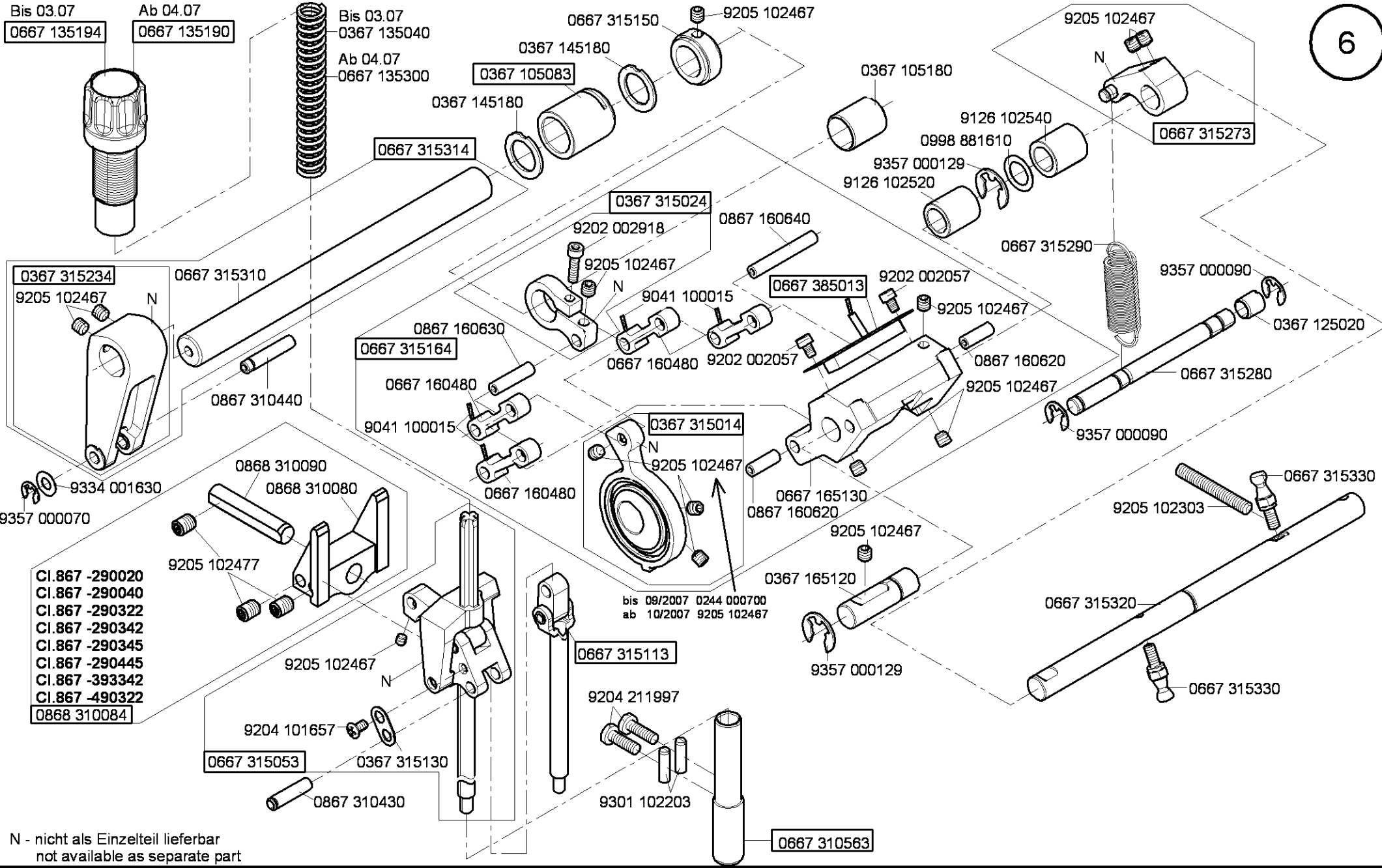

N - nicht als Einzelteil lieferbar
not available as separate part

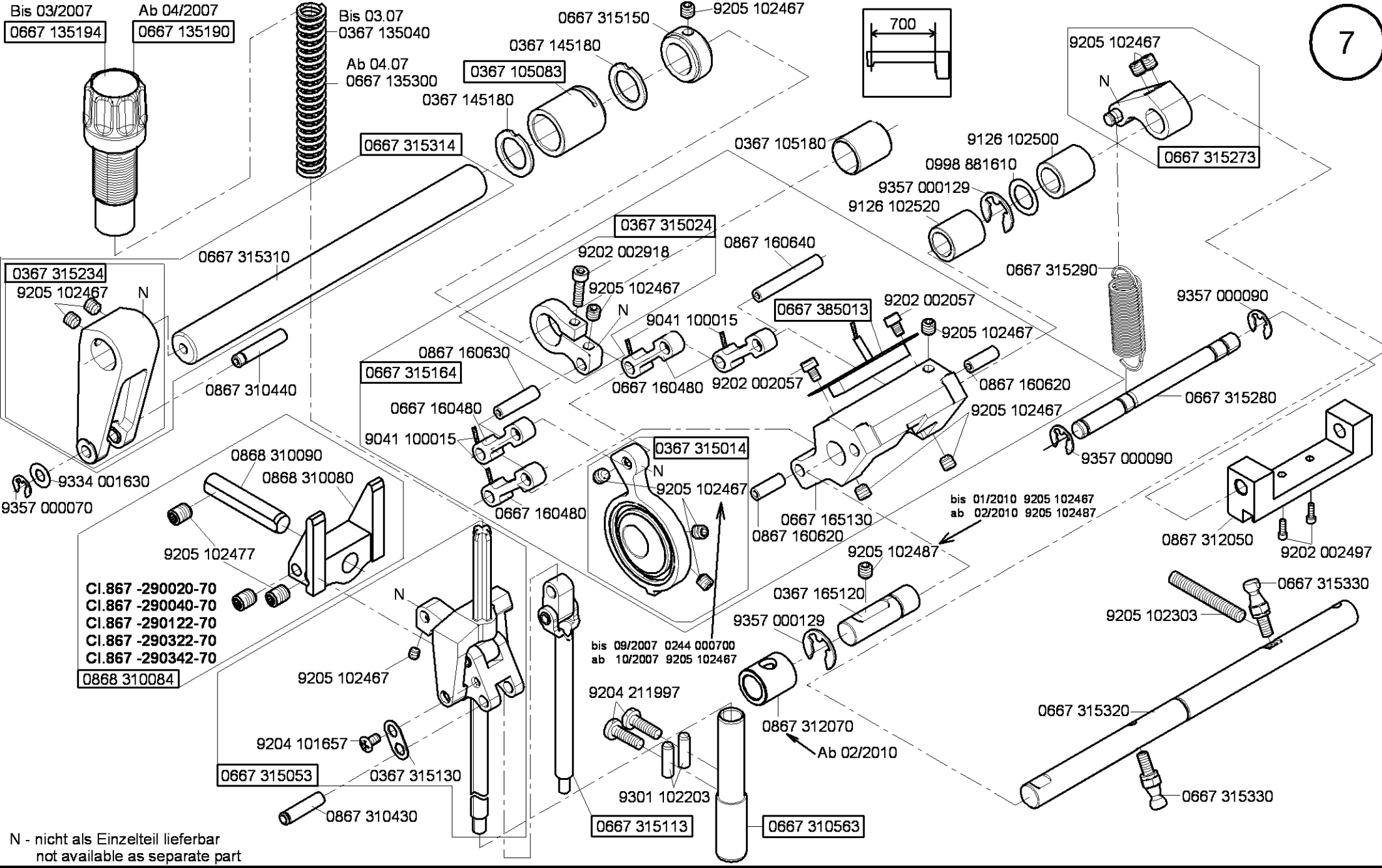

N - nicht als Einzelteil lieferbar
 not available as separate part

bis 09/2007 0244 000700
ab 10/2007 9205 102467

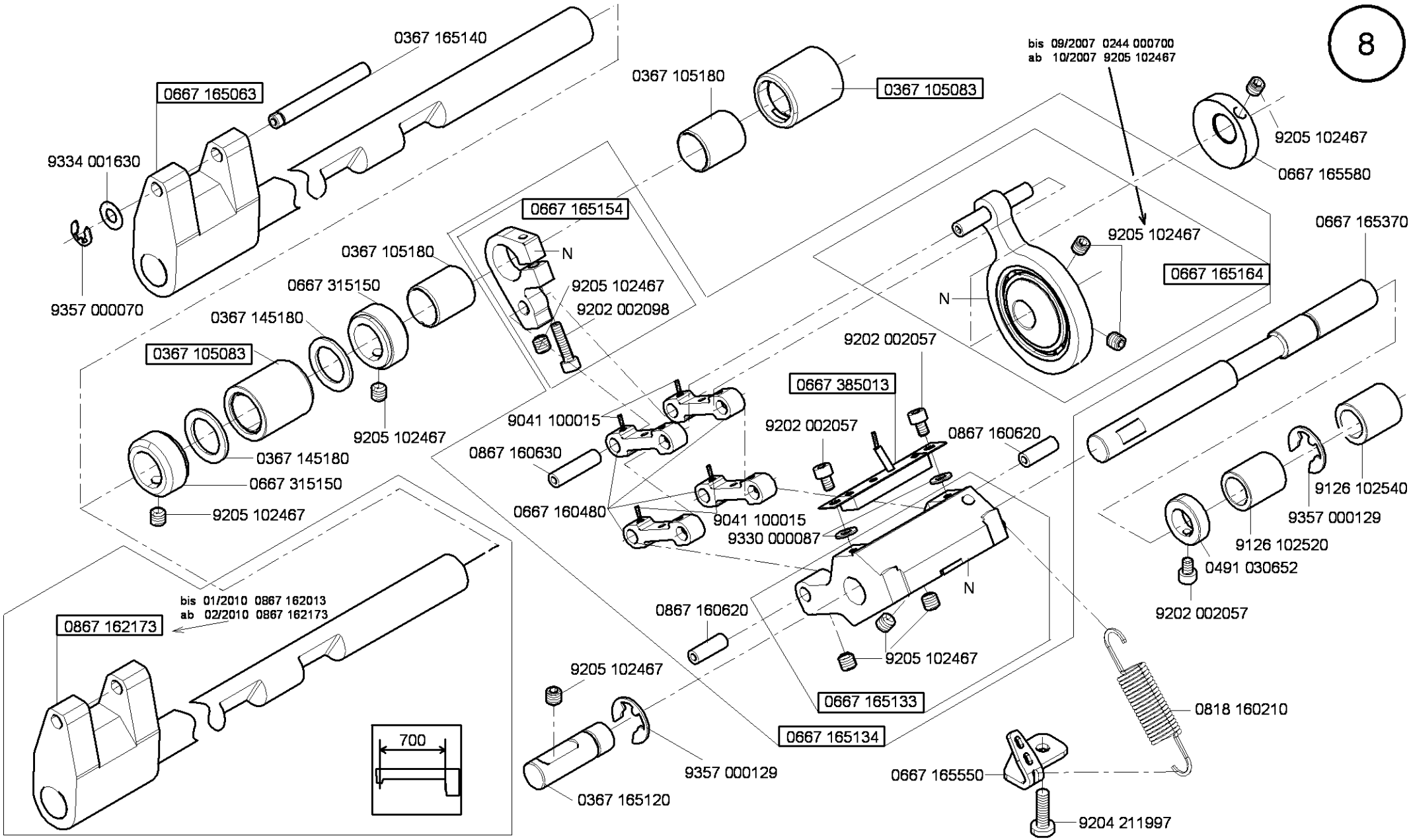

N - nicht als Einzelteil lieferbar
not available as separate part

- CI.867 -190020
- CI.867 -190040
- CI.867 -190122
- CI.867 -190142
- CI.867 -190145
- CI.867 -190322
- CI.867 -190342
- CI.867 -190445
- CI.867 -290020
- CI.867 -290040
- CI.867 -290322
- CI.867 -290342
- CI.867 -290445
- CI.867 -392342
- CI.867 -490322
- CI.867 -190040-70
- CI.867 -100342-70
- CI.867 -290040-70
- CI.867 -290342-70

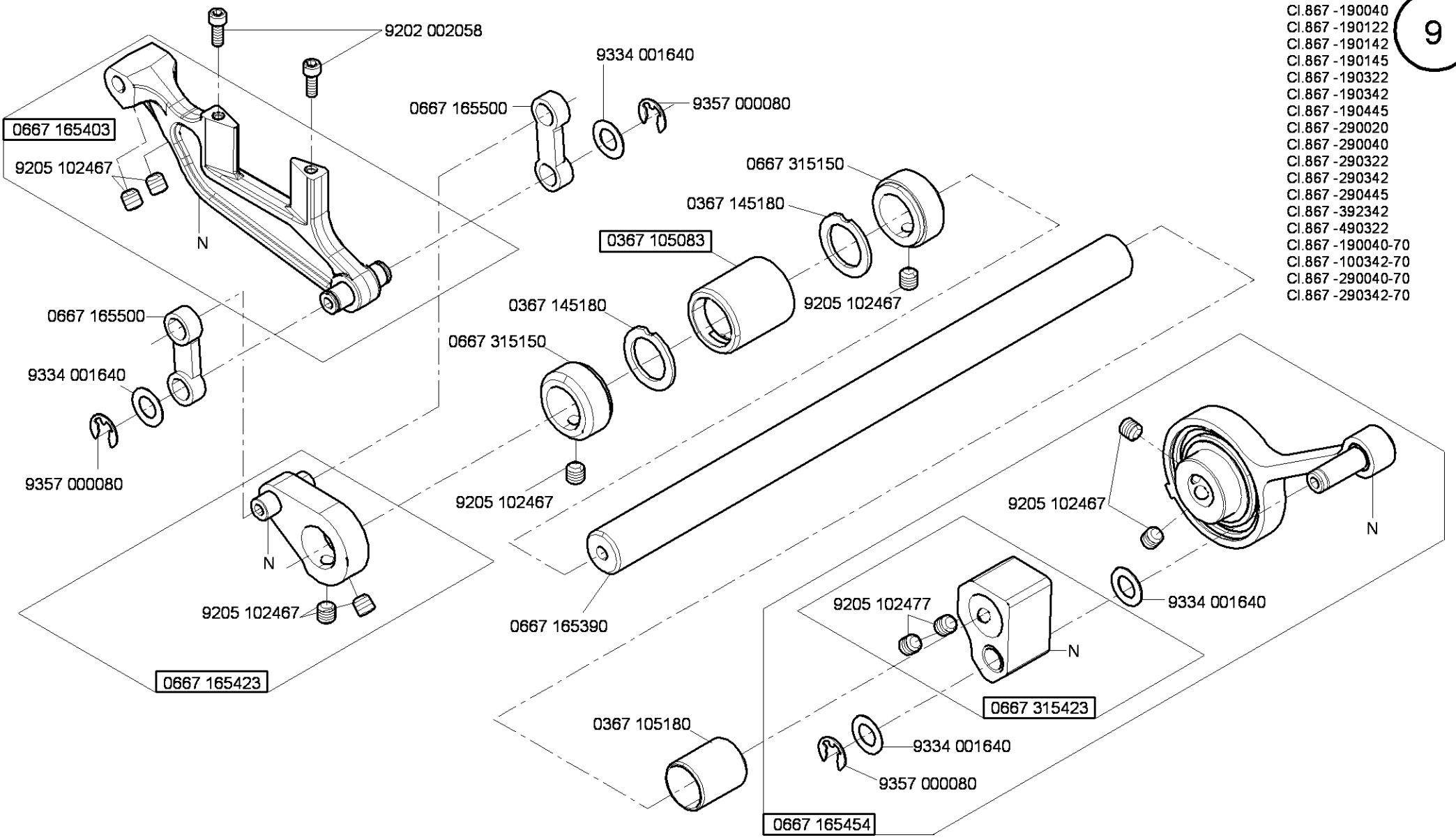

N - nicht als Einzelteil lieferbar
not available as separate part

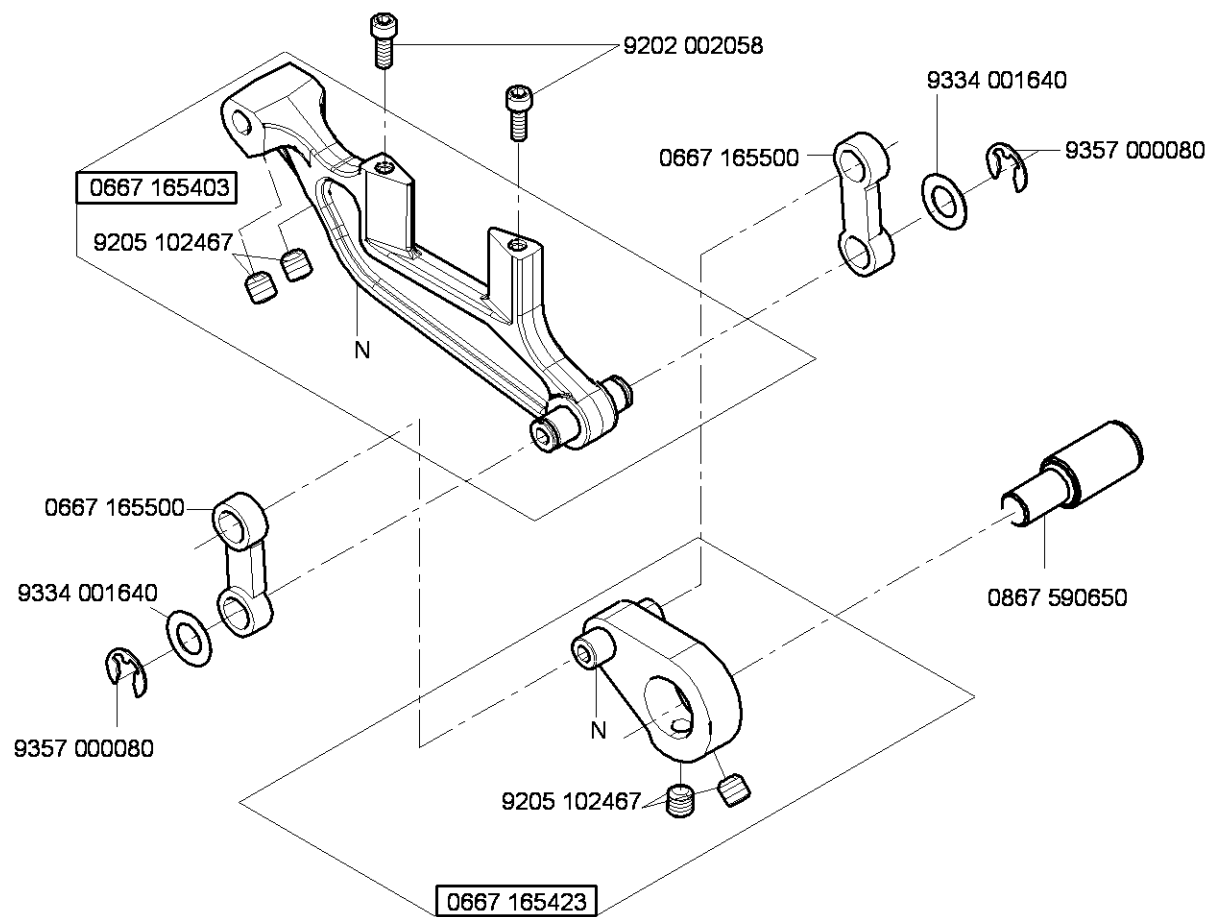

N - nicht als Einzelteil lieferbar
not available as separate part

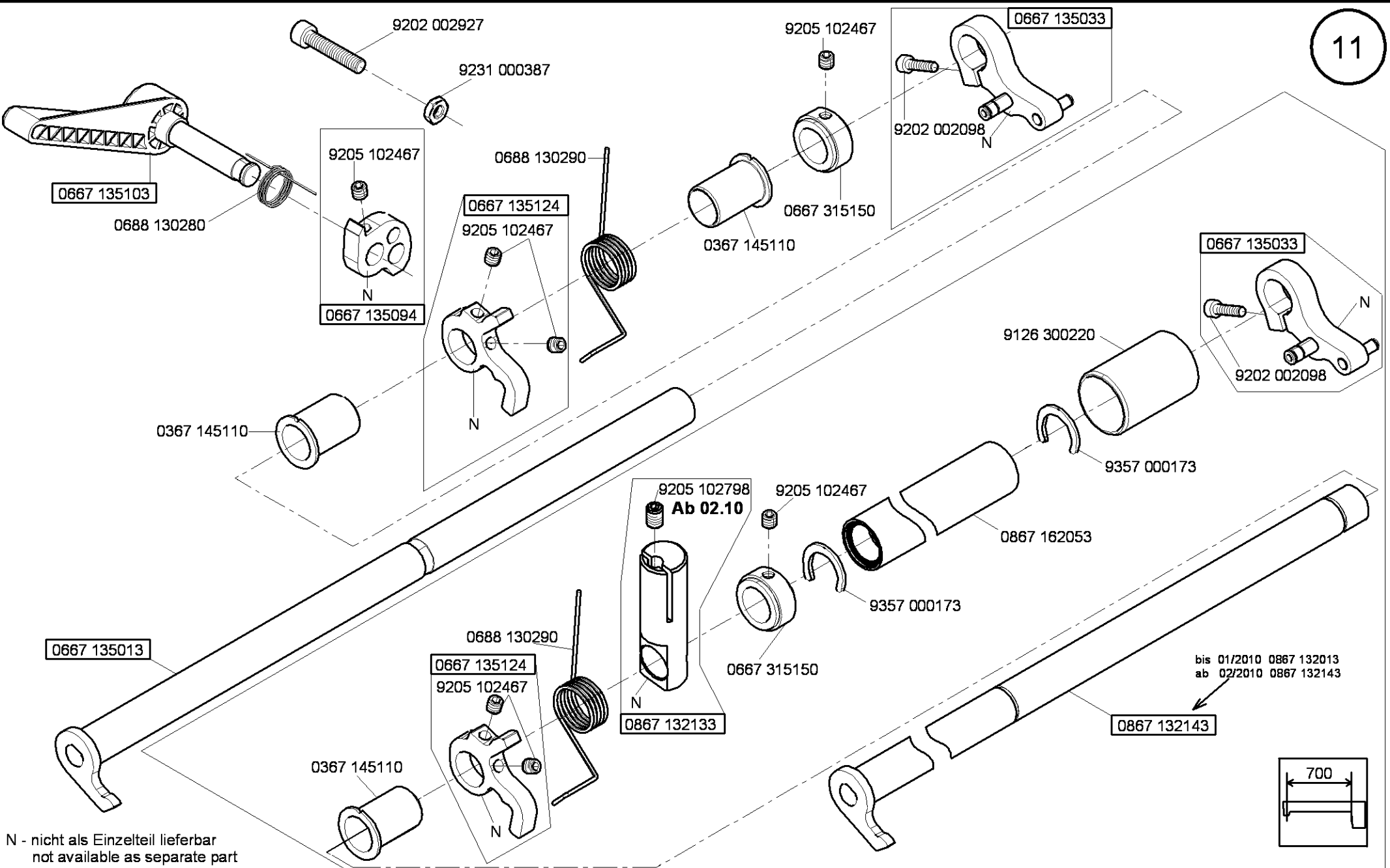

N - nicht als Einzelteil lieferbar
not available as separate part

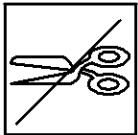

Cl. 867 -190020
Cl.867 -190040
Cl.867 -290020
Cl.867 -290040
Cl.867 -190040-70
Cl.867 -290040-70

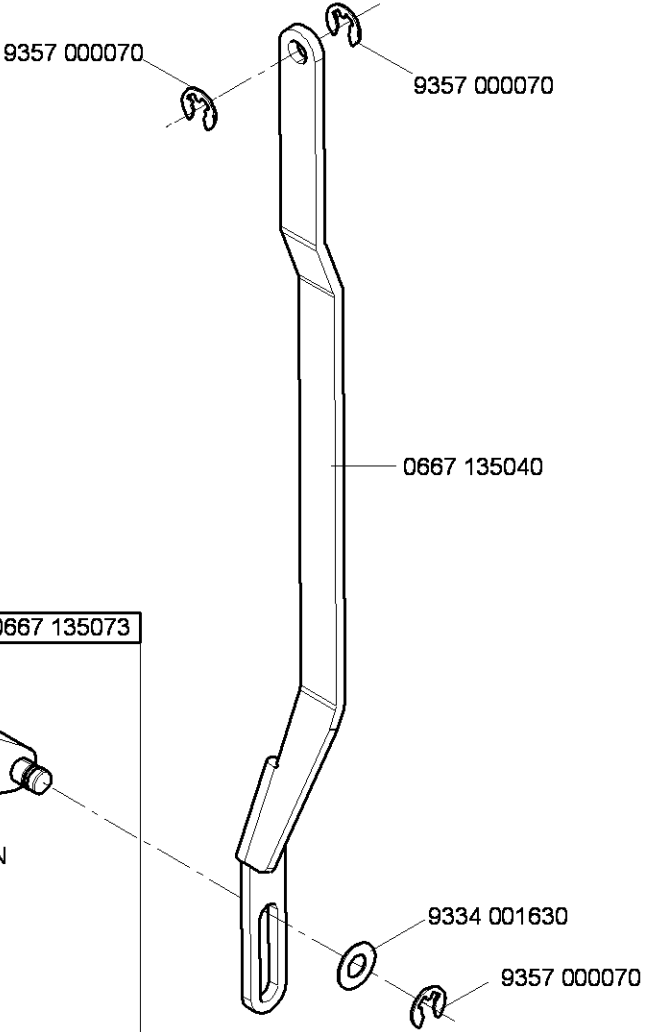
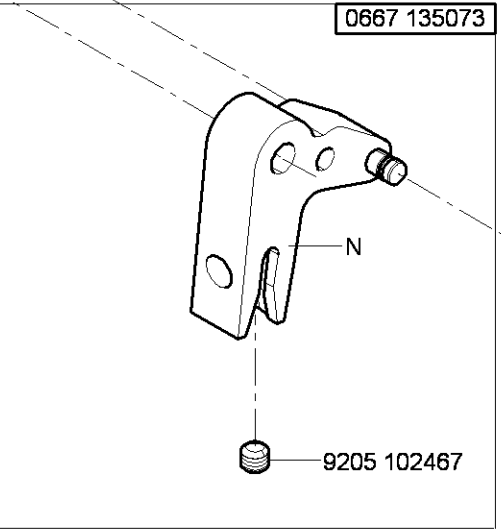
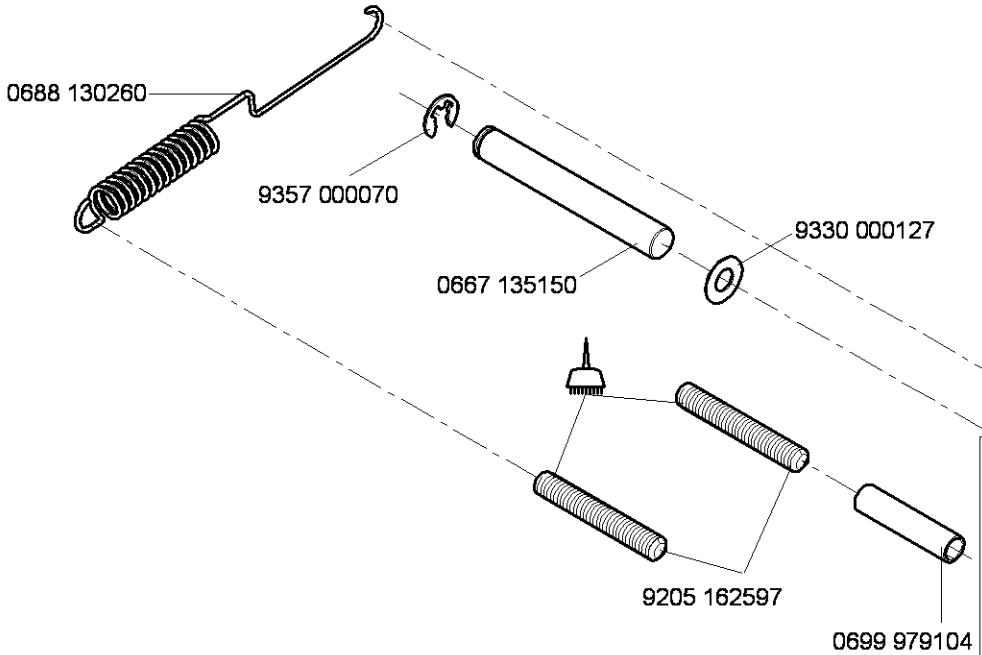

N - nicht als Einzelteil lieferbar
not available as separate part  -kleben -stick

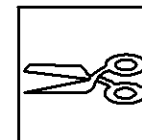
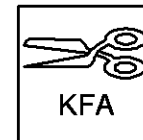

- Cl.867 -190122
- Cl.867 -190125
- Cl.867 -190142
- Cl.867 -190145
- Cl.867 -190322
- Cl.867 -190342
- Cl.867 -190425
- Cl.867 -190445
- Cl.867 -290122
- Cl.867 -290142
- Cl.867 -290322
- Cl.867 -290342
- Cl.867 -290445
- Cl.867 -392342
- Cl.867 -393342
- Cl.867 -394342
- Cl.867 -490322
- Cl.867 -190342-70
- Cl.867 -290342-70

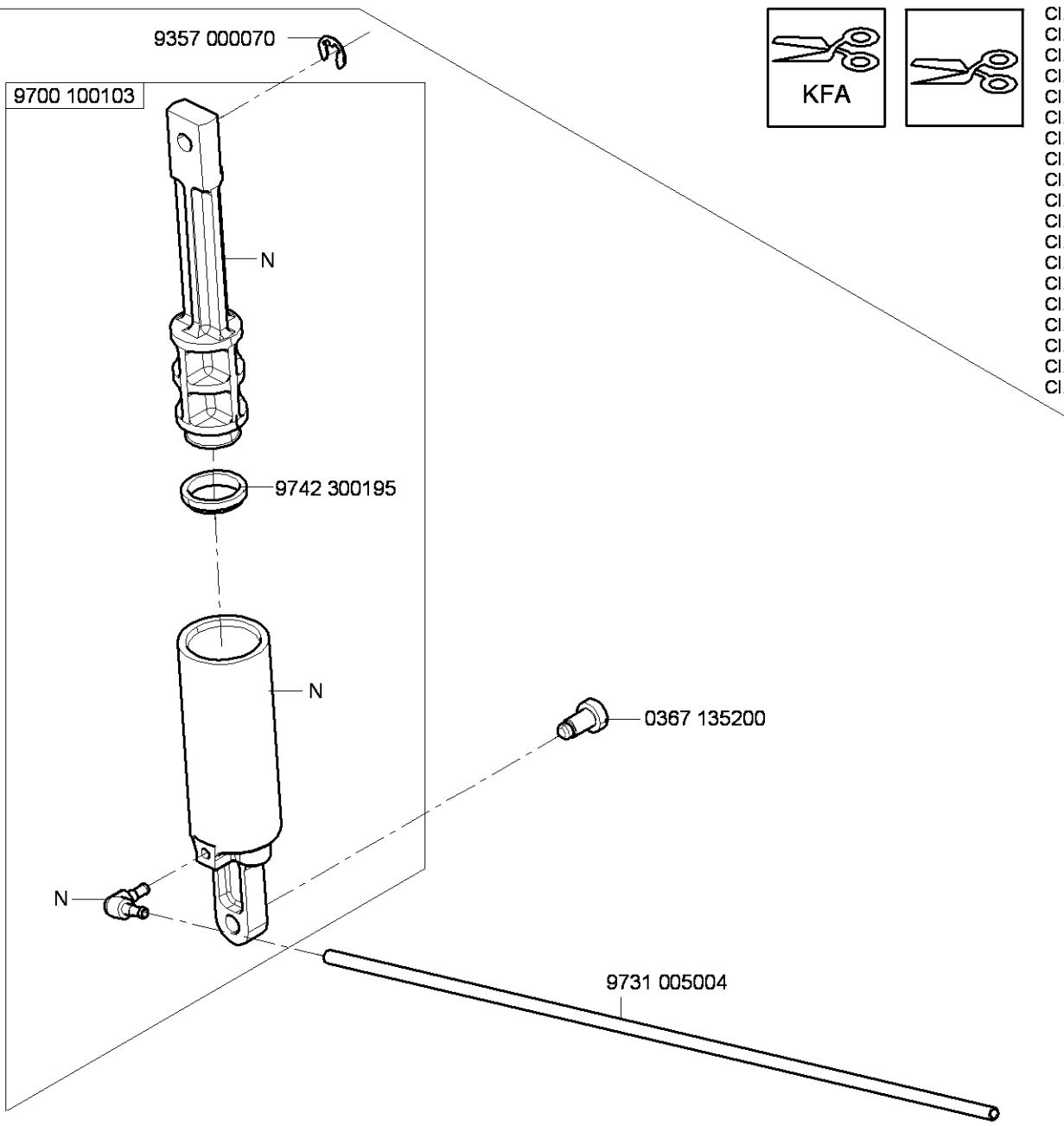

N - nicht als Einzelteil lieferbar
not available as separate part

0667 135204

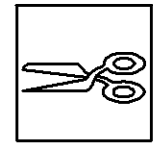
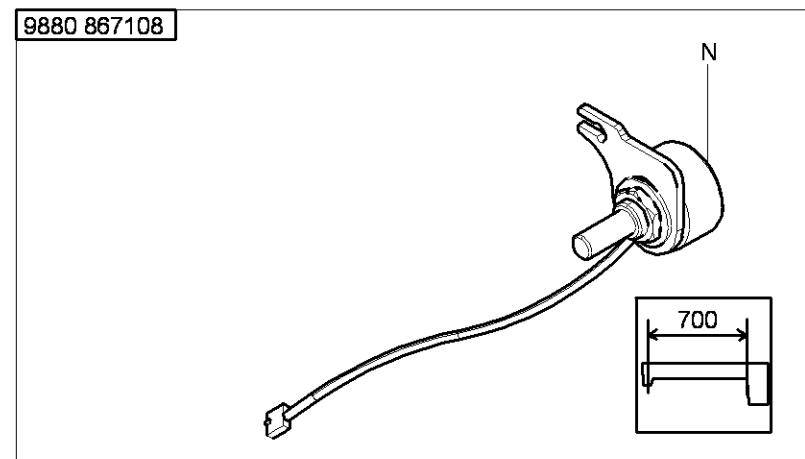
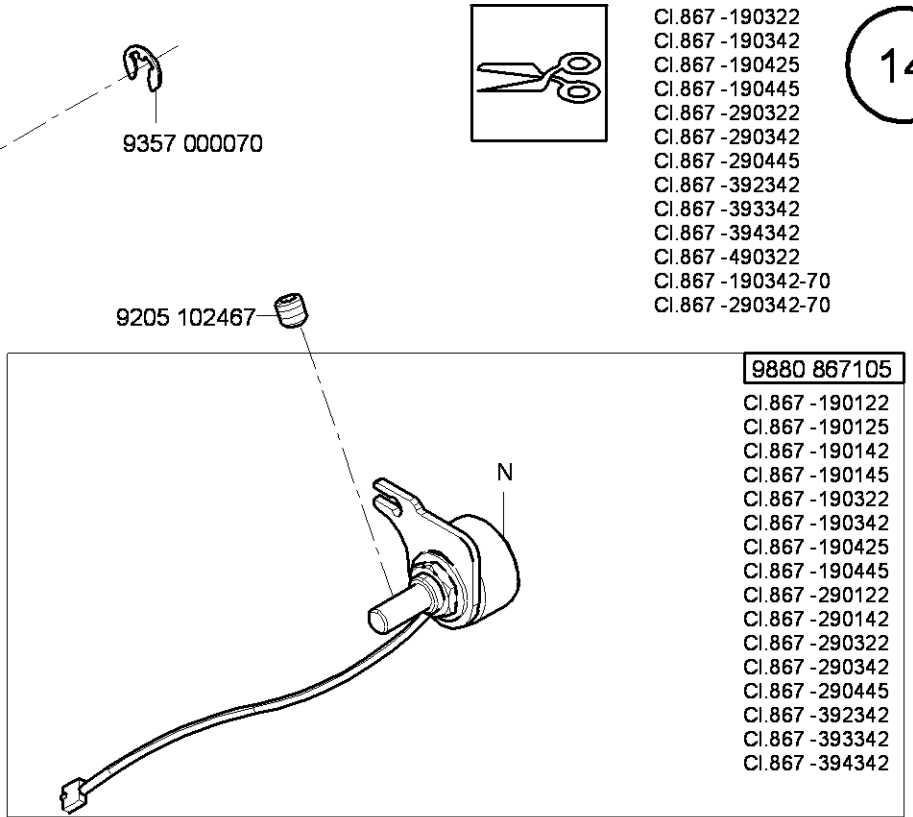
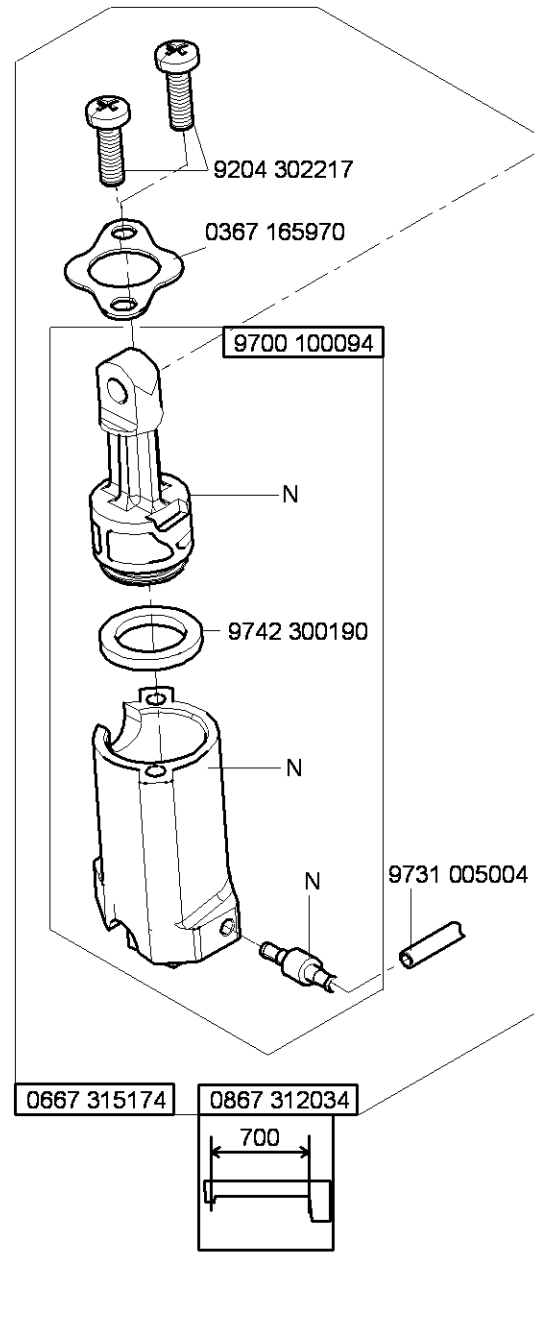
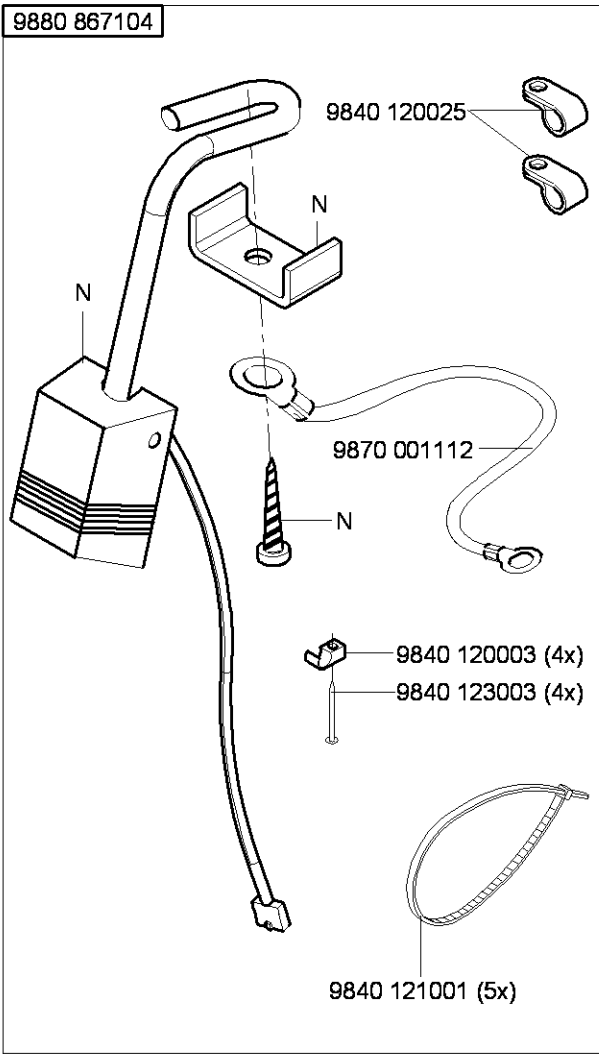

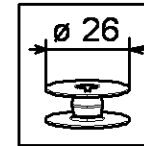

CI.867 -190020
CI.867 -190122
CI.867 -190322
CI.867 -290020
CI.867 -290122
CI.867 -290322
CI.867 -490322

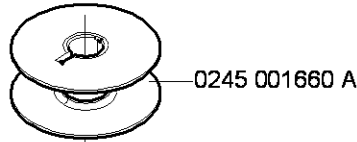

0667 155604

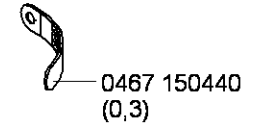
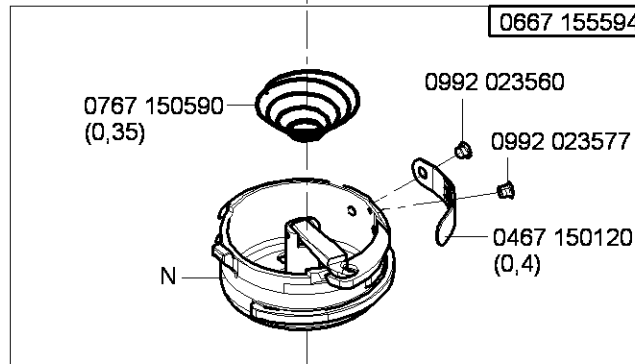

auf Wunsch
on request

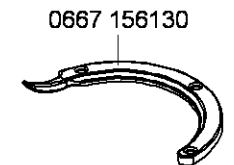
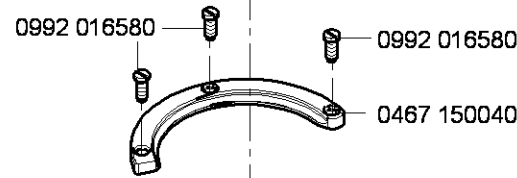

auf Wunsch
on request

alte Version bis 10.2006
old version until 10.2006

9202 001653

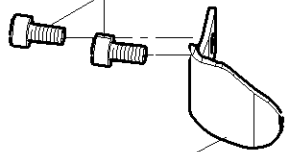

0667 155660

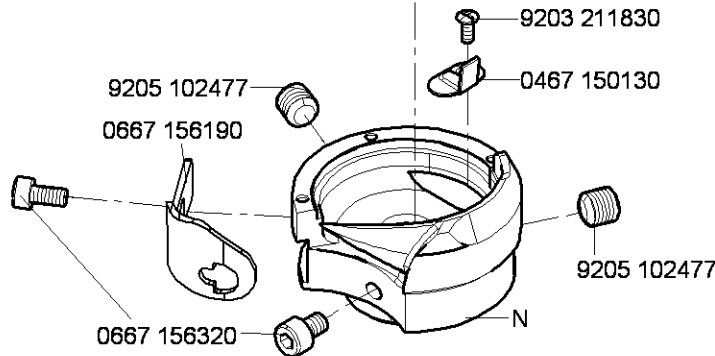

N - nicht als Einzelteil lieferbar
not available as separate part

auf Wunsch
on request

DLC - beschichtet für minimale ölschmierung
DLC - coated for minimal lubrication

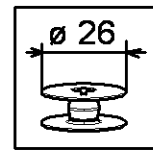

- CI.867 -190020
- CI.867 -190122
- CI.867 -190322
- CI.867 -290020
- CI.867 -290322

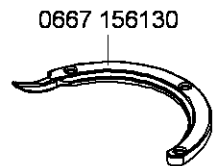
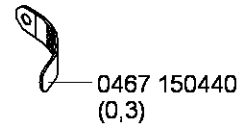
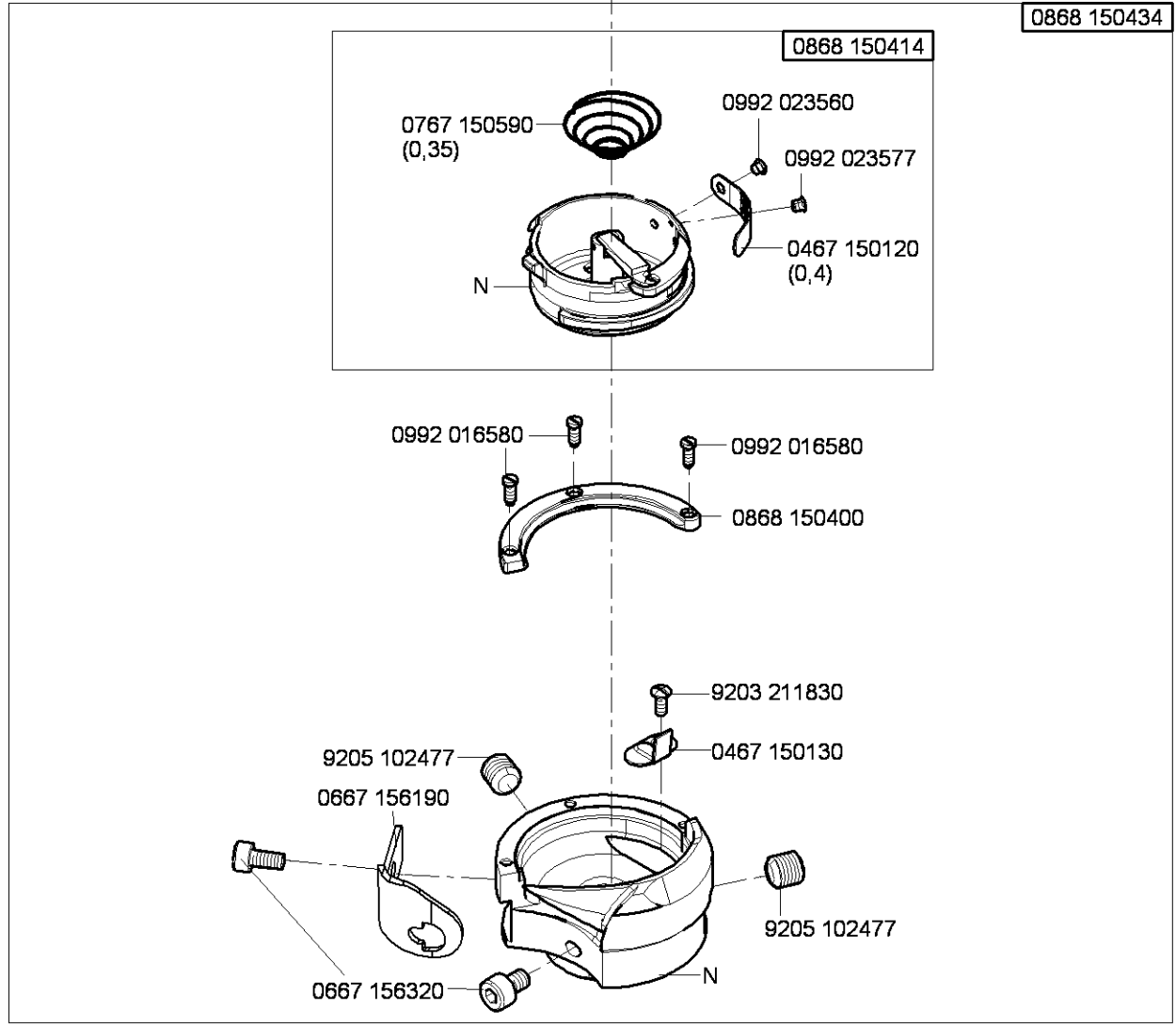
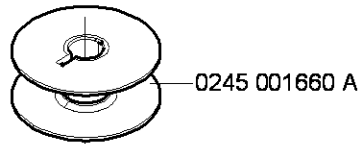

N - nicht als Einzelteil lieferbar
not available as separate part

auf Wunsch
on request

0667 150870
(0,45)

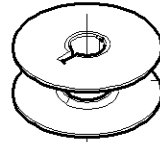

0667 150830

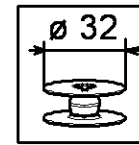

CI.867 -190040
CI.867 -190142
CI.867 -190342
CI.867 -290040
CI.867 -290142
CI.867 -290342
CI.867 -392342
CI.867 -393342
CI.867 -394342
CI.867 -190040-70
CI.867 -190342-70
CI.867 -290040-70
CI.867 -290342-70

0667 155634

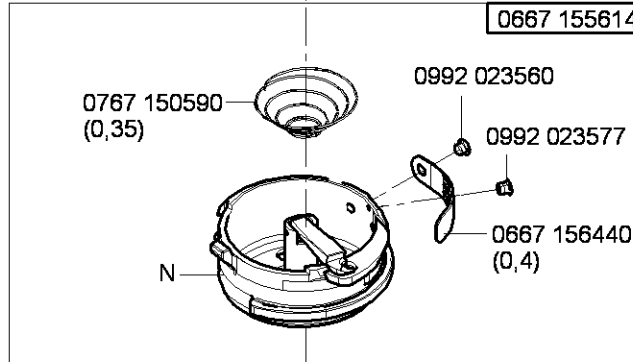

0467 150440
(0,3)

auf Wunsch
on request

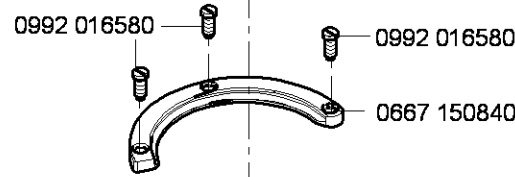

0667 156210

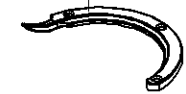

auf Wunsch
on request

alte Version bis 10.2006
old version until 10.2006

9202 001653

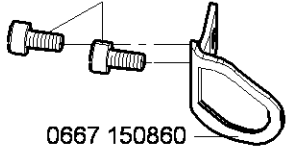

0667 150860

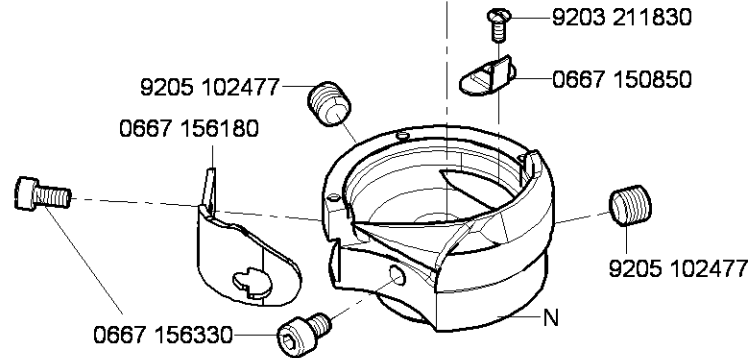

N - nicht als Einzelteil lieferbar
not available as separate part

auf Wunsch
on request

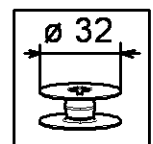

- CI.867 -190040
- CI.867 -190142
- CI.867 -190342
- CI.867 -290040
- CI.867 -290142
- CI.867 -290342
- CI.867 -392342
- CI.867 -393342
- CI.867 -394342
- CI.867 -190040-70
- CI.867 -190342-70
- CI.867 -290040-70
- CI.867 -290342-70

DLC - beschichtet für minimale ölschmierung
DLC - coated for minimal lubrication

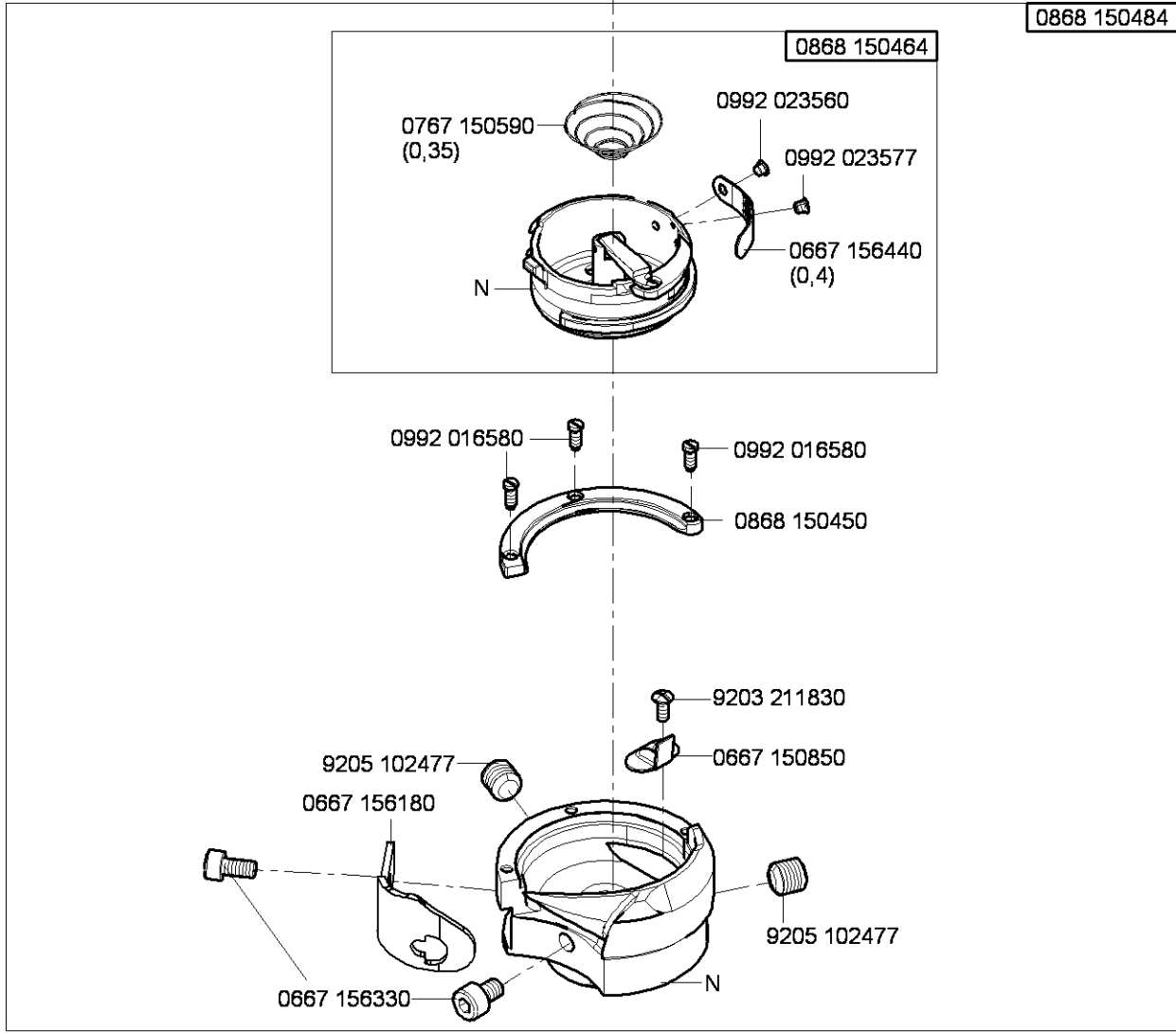

auf Wunsch
on request

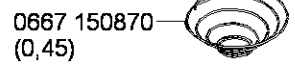

N - nicht als Einzelteil lieferbar
not available as separate part

auf Wunsch
on request

0667 150870
(0,45)

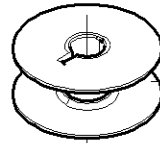

0667 150830

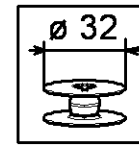
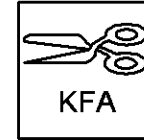

CI.867 -190145
CI.867 -190445
CI.867 -290445

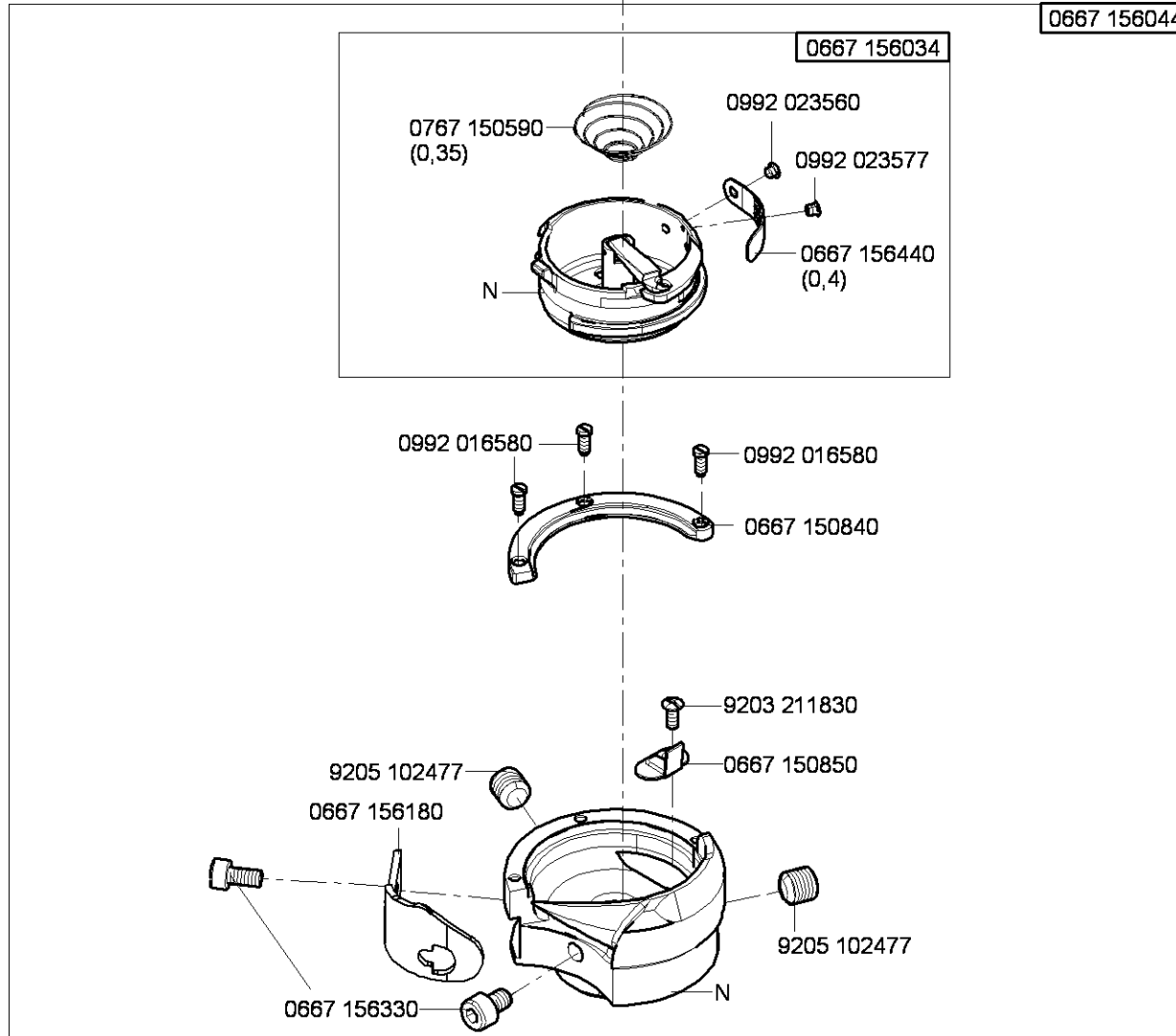

0667 156044



0467 150440
(0,3)

auf Wunsch
on request

0667 156210

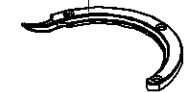

auf Wunsch
on request

N - nicht als Einzelteil lieferbar
not available as separate part

auf Wunsch
on request

0667 150870
(0,45)

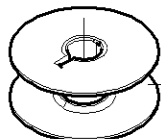

0667 150830

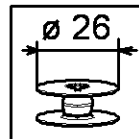
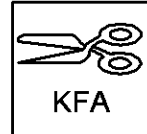

Cl.867 -190125
Cl.867 -190425

20

0867 150214

0867 150204

0767 150590
(0,35)

0992 023560

0992 023577

N

0467 150120
(0,4)



0467 150440
(0,3)

auf Wunsch
on request

0992 016580

0992 016580

0667 150840

0667 156210

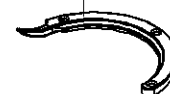

auf Wunsch
on request

9203 211830

0667 150850

9205 102477

0667 156190

9205 102477

0667 156330

N

N - nicht als Einzelteil lieferbar
not available as separate part

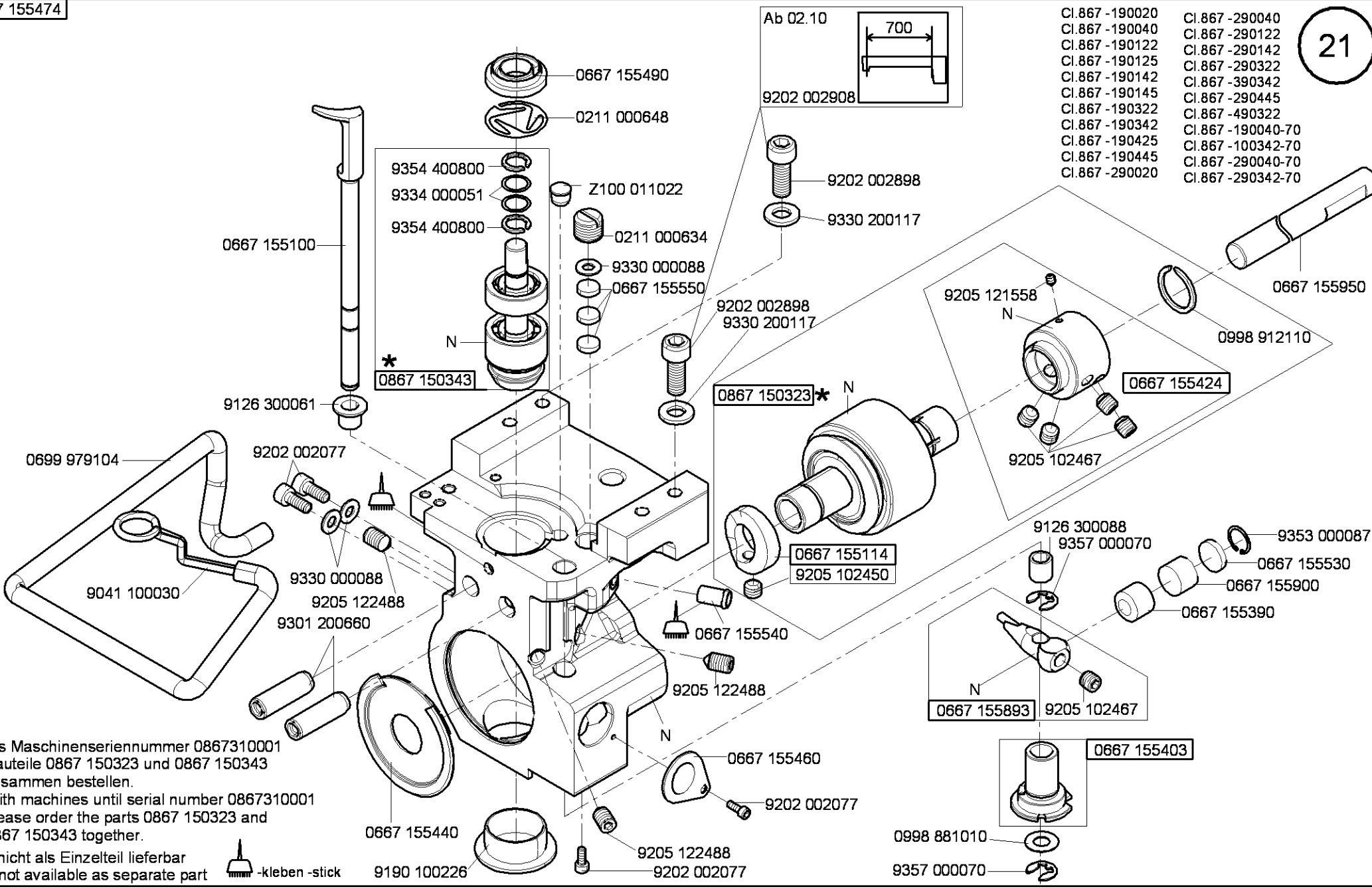

- CI.867 -190020
- CI.867 -190040
- CI.867 -190122
- CI.867 -190125
- CI.867 -190142
- CI.867 -190145
- CI.867 -190322
- CI.867 -190342
- CI.867 -190425
- CI.867 -190445
- CI.867 -290020
- CI.867 -290040
- CI.867 -290122
- CI.867 -290142
- CI.867 -290322
- CI.867 -390342
- CI.867 -290445
- CI.867 -490322
- CI.867 -190040-70
- CI.867 -100342-70
- CI.867 -290040-70
- CI.867 -290342-70

* Bis Maschinenseriennummer 0867310001
 Bauteile 0867 150323 und 0867 150343
 zusammen bestellen.
 With machines until serial number 0867310001
 please order the parts 0867 150323 and
 0867 150343 together.

N - nicht als Einzelteil lieferbar
 not available as separate part



- CI.867 -290020
- CI.867 -290040
- CI.867 -290122
- CI.867 -290142
- CI.867 -290322
- CI.867 -290342
- CI.867 -290445
- CI.867 -392342
- CI.867 -393342
- CI.867 -394342
- CI.867 -490322
- CI.867 -290040-70
- CI.867 -290342-70

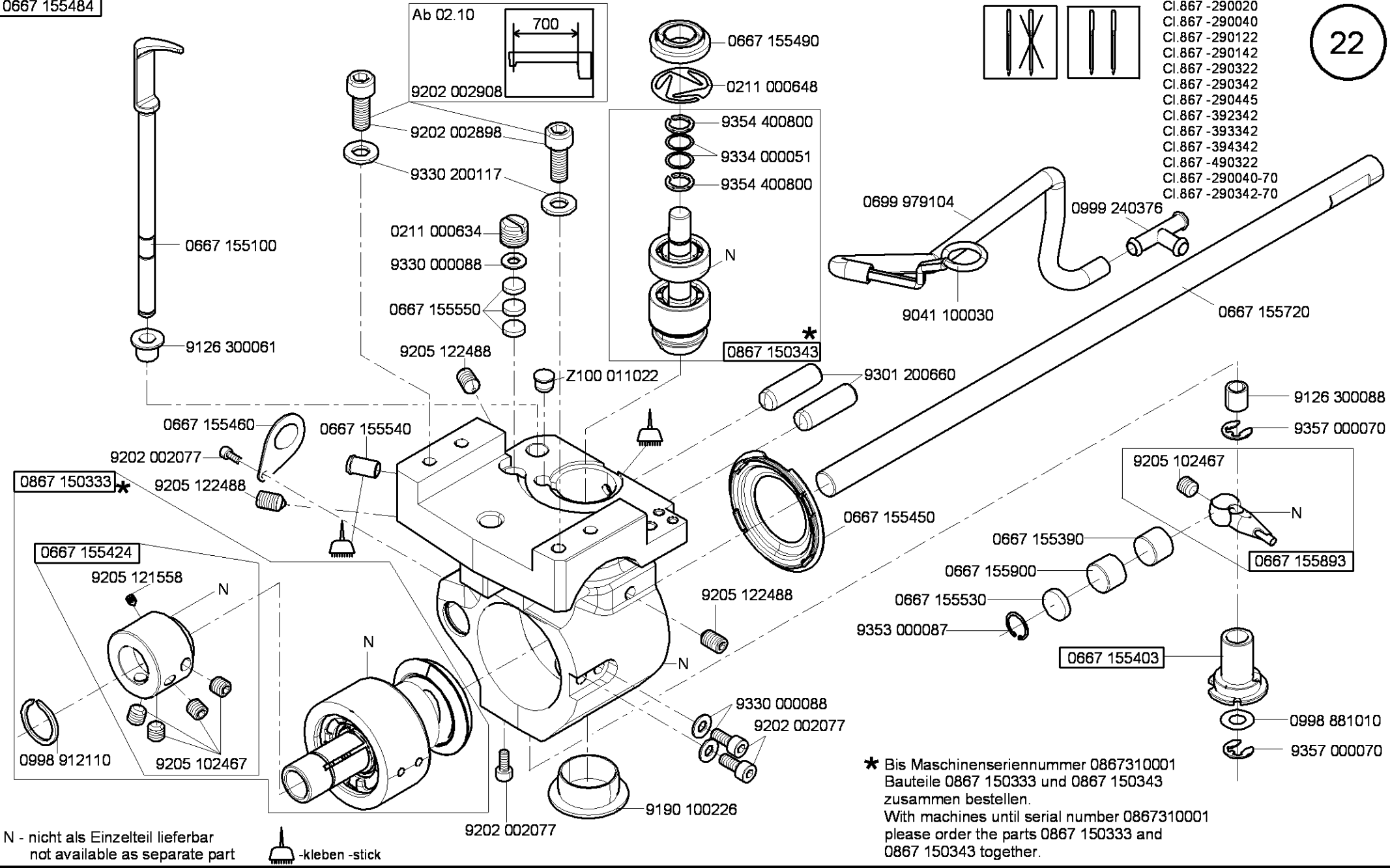

N - nicht als Einzelteil lieferbar
not available as separate part

-kleben -stick

* Bis Maschinenseriennummer 0867310001
Bauteile 0867 150333 und 0867 150343
zusammen bestellen.
With machines until serial number 0867310001
please order the parts 0867 150333 and
0867 150343 together.

- CI.867 -190122
- CI.867 -190142
- CI.867 -190322
- CI.867 -190342
- CI.867 -290122
- CI.867 -290142
- CI.867 -290322
- CI.867 -290342
- CI.867 -392342
- CI.867 -393342
- CI.867 -394342
- CI.867 -490322
- CI.867 -190342-70
- CI.867 -290342-70

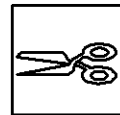

9870 867001

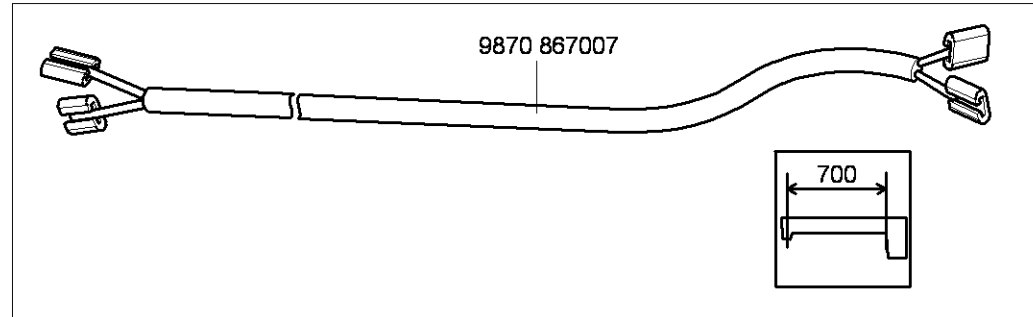
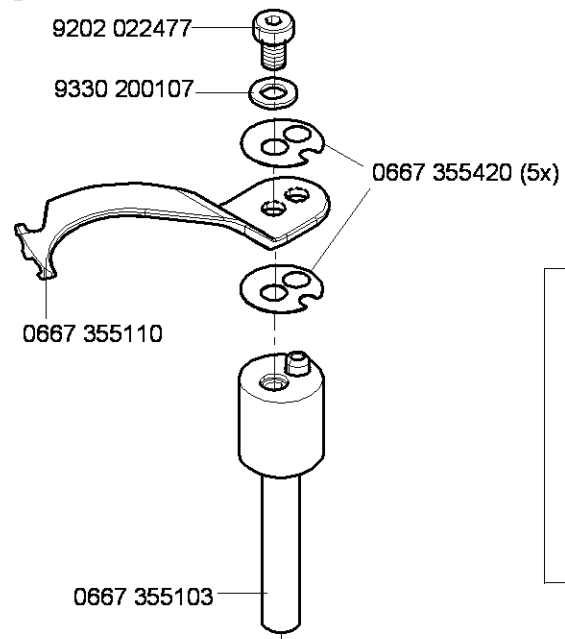
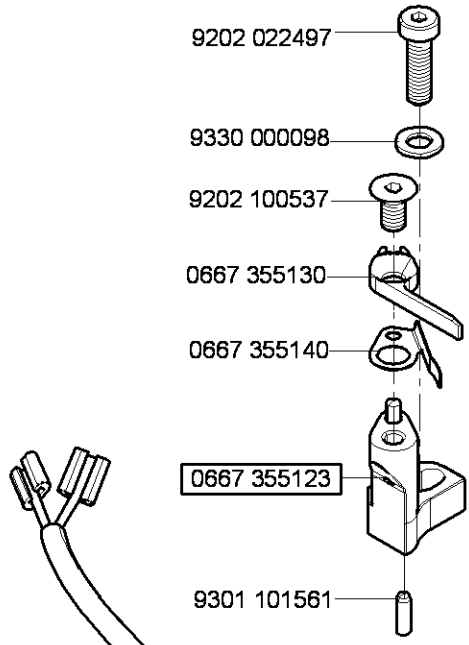

9870 867007

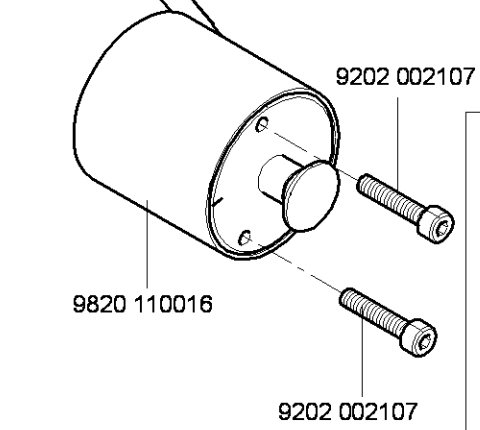
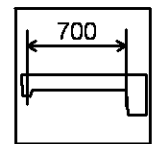

9820 110016

9202 002107

9202 002107

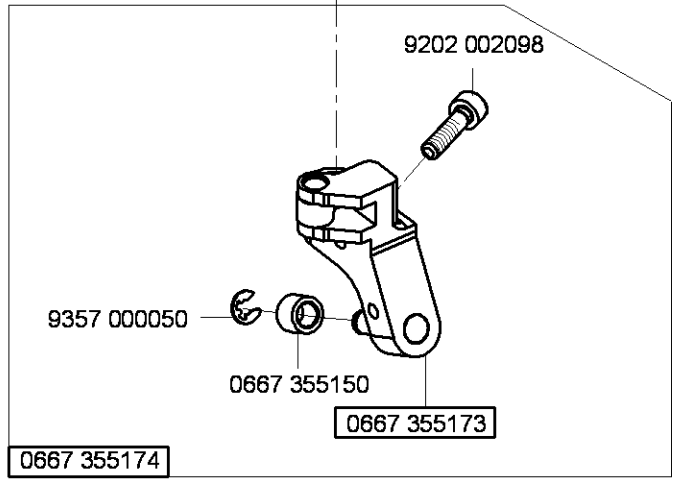

9202 002098

9357 000050

0667 355150

0667 355173

0667 355174

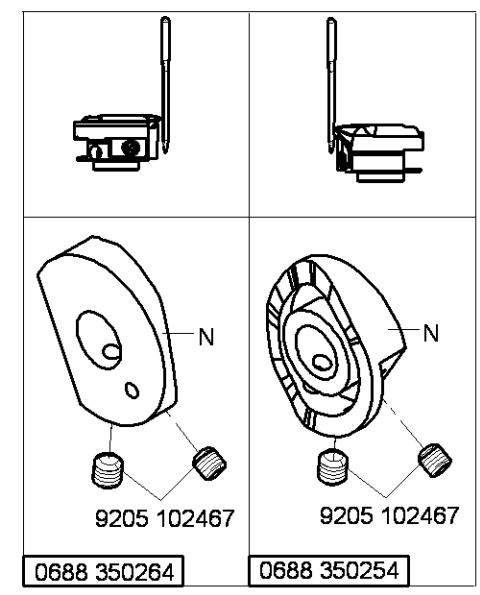

9205 102467

9205 102467

0688 350264

0688 350254

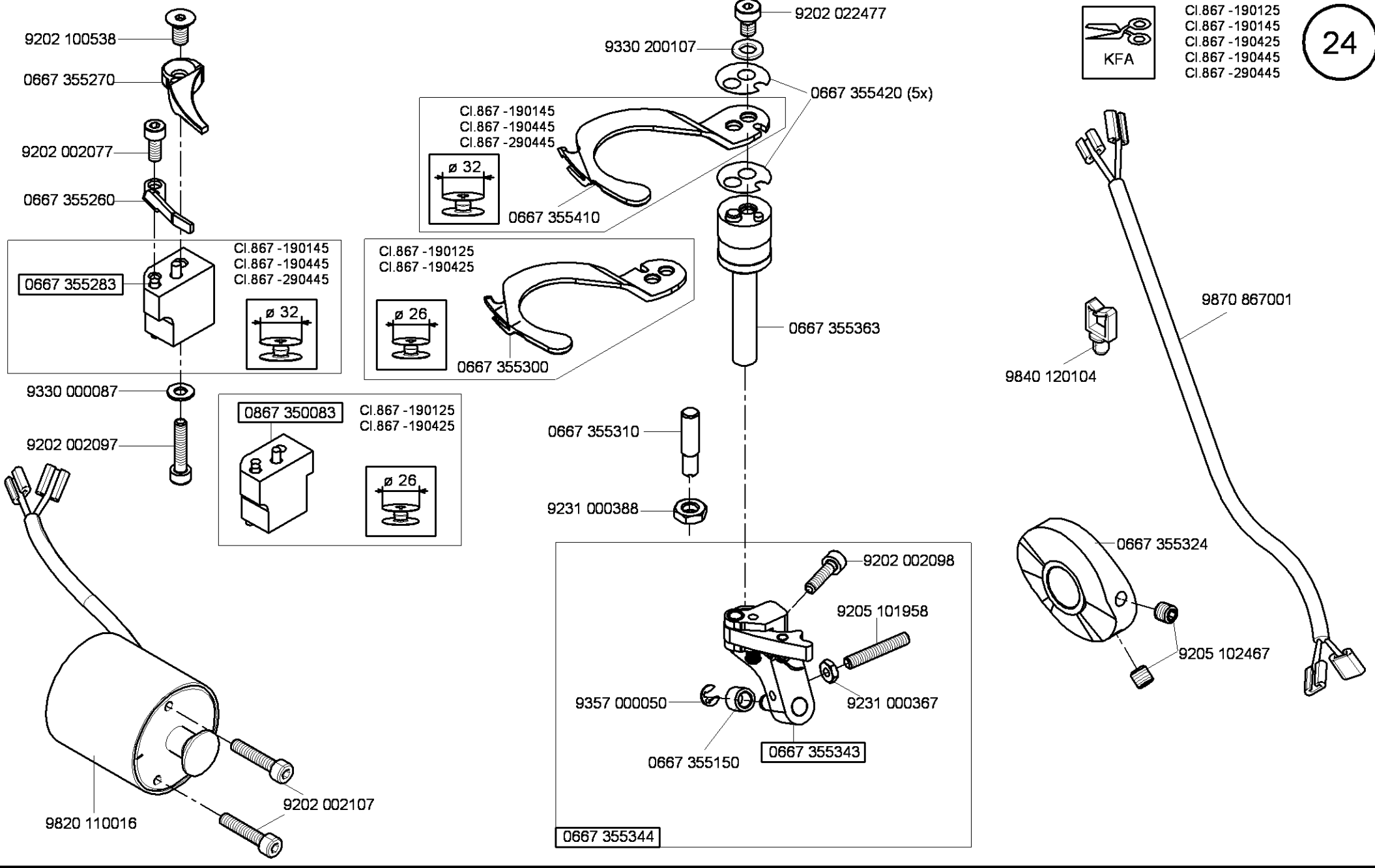

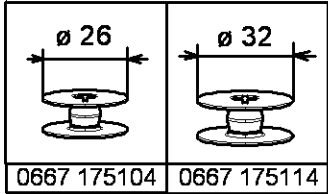
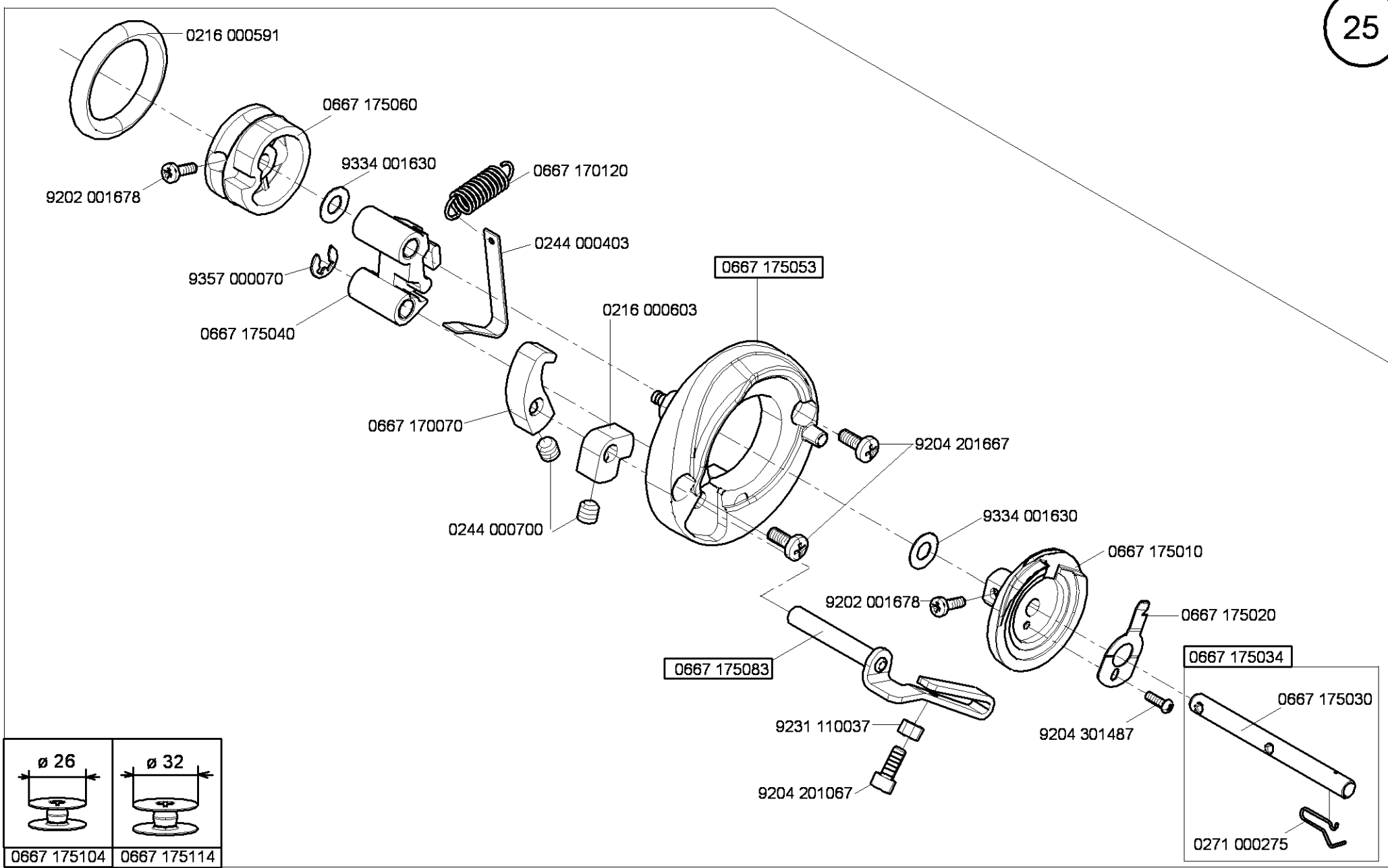

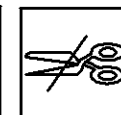
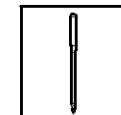

CI.867 -190020
 CI.867 -190040
 CI.867 -190040-70

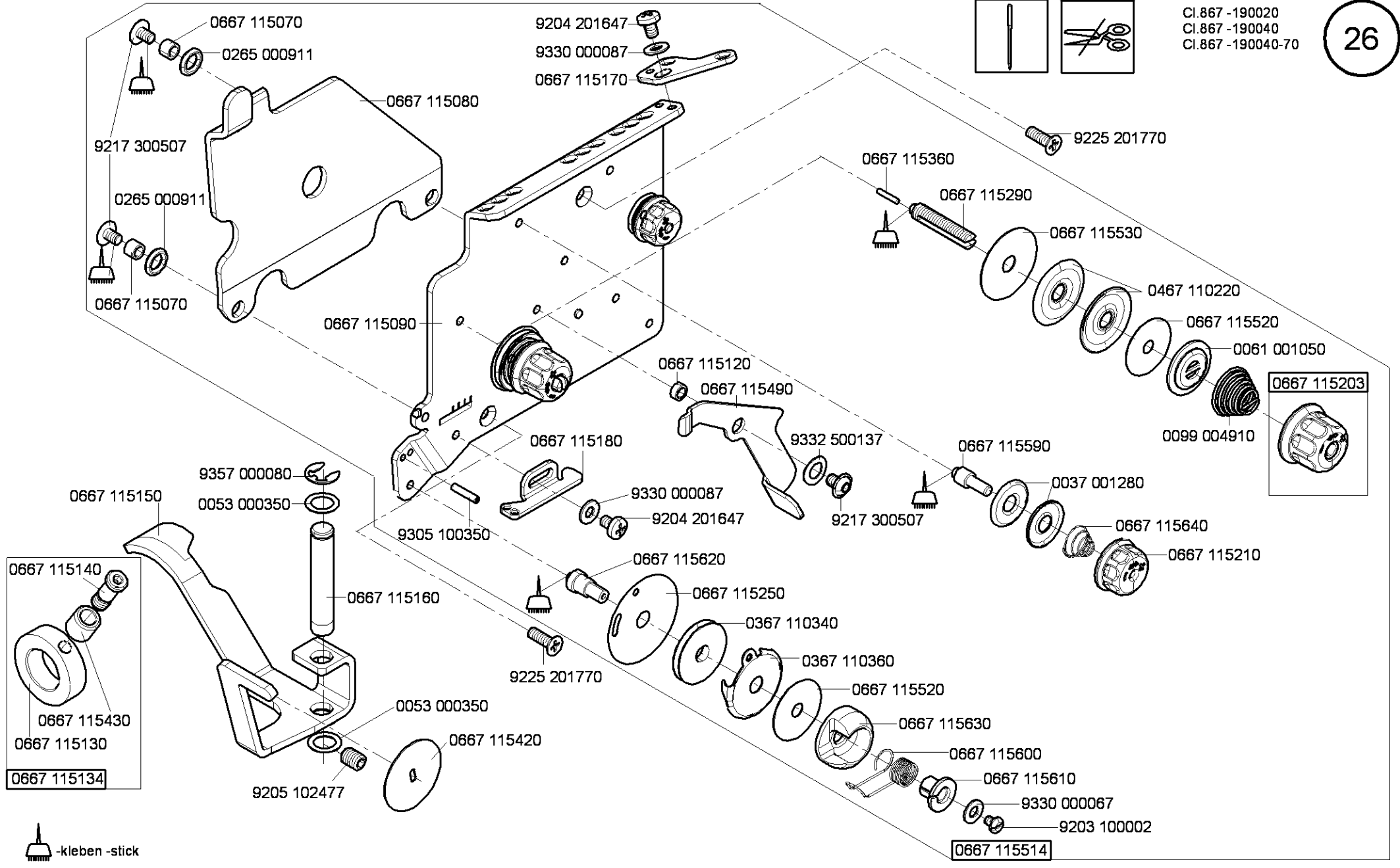

-kleben -stick

- Cl.867 -190125
- Cl.867 -190145
- Cl.867 -190425
- Cl.867 -190322
- Cl.867 -190342
- Cl.867 -190445
- Cl.867 -392342
- Cl.867 -393342
- Cl.867 -394343
- Cl.867 -190342-70

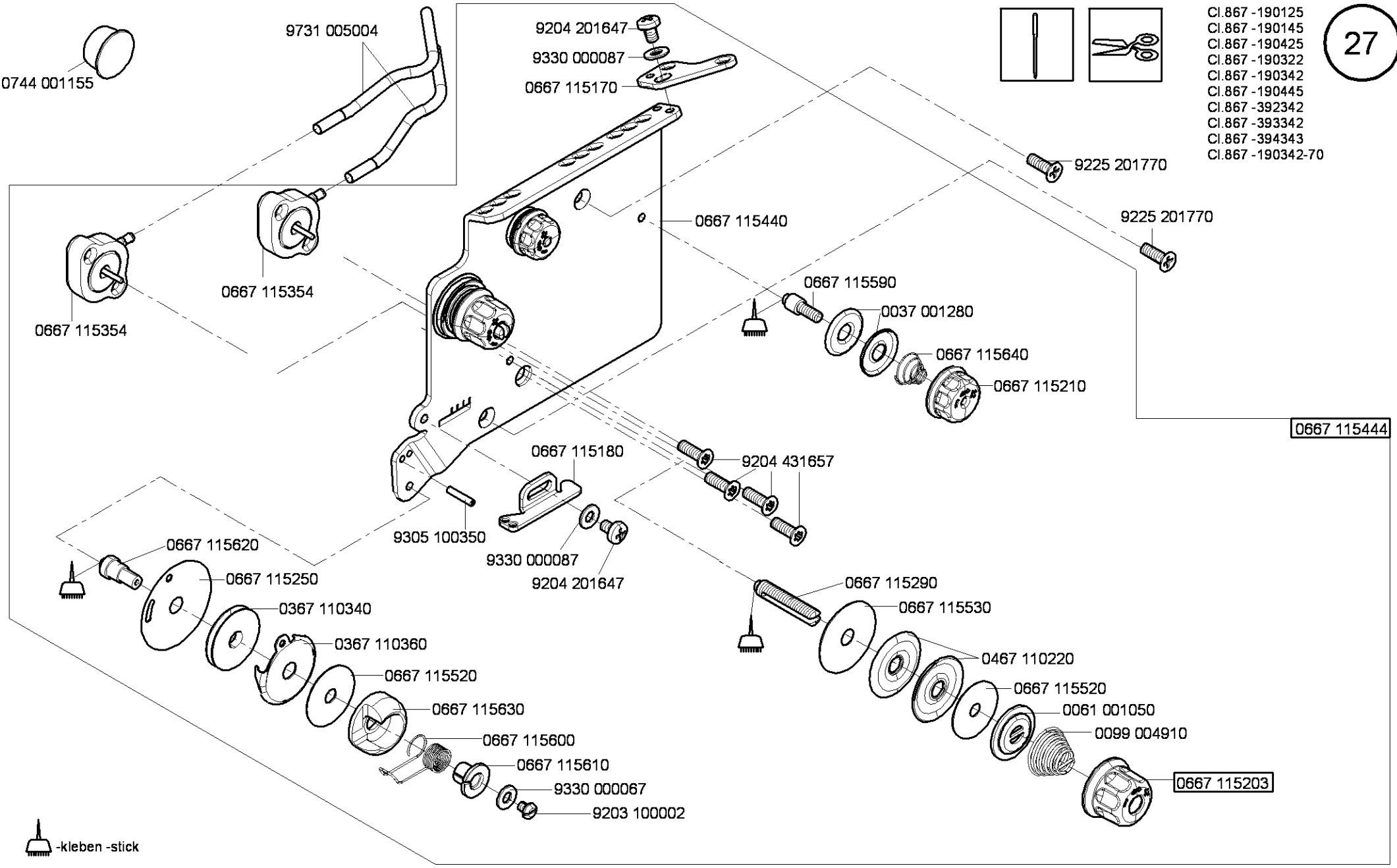
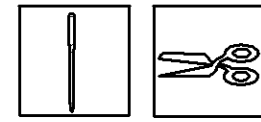

-kleben -stick

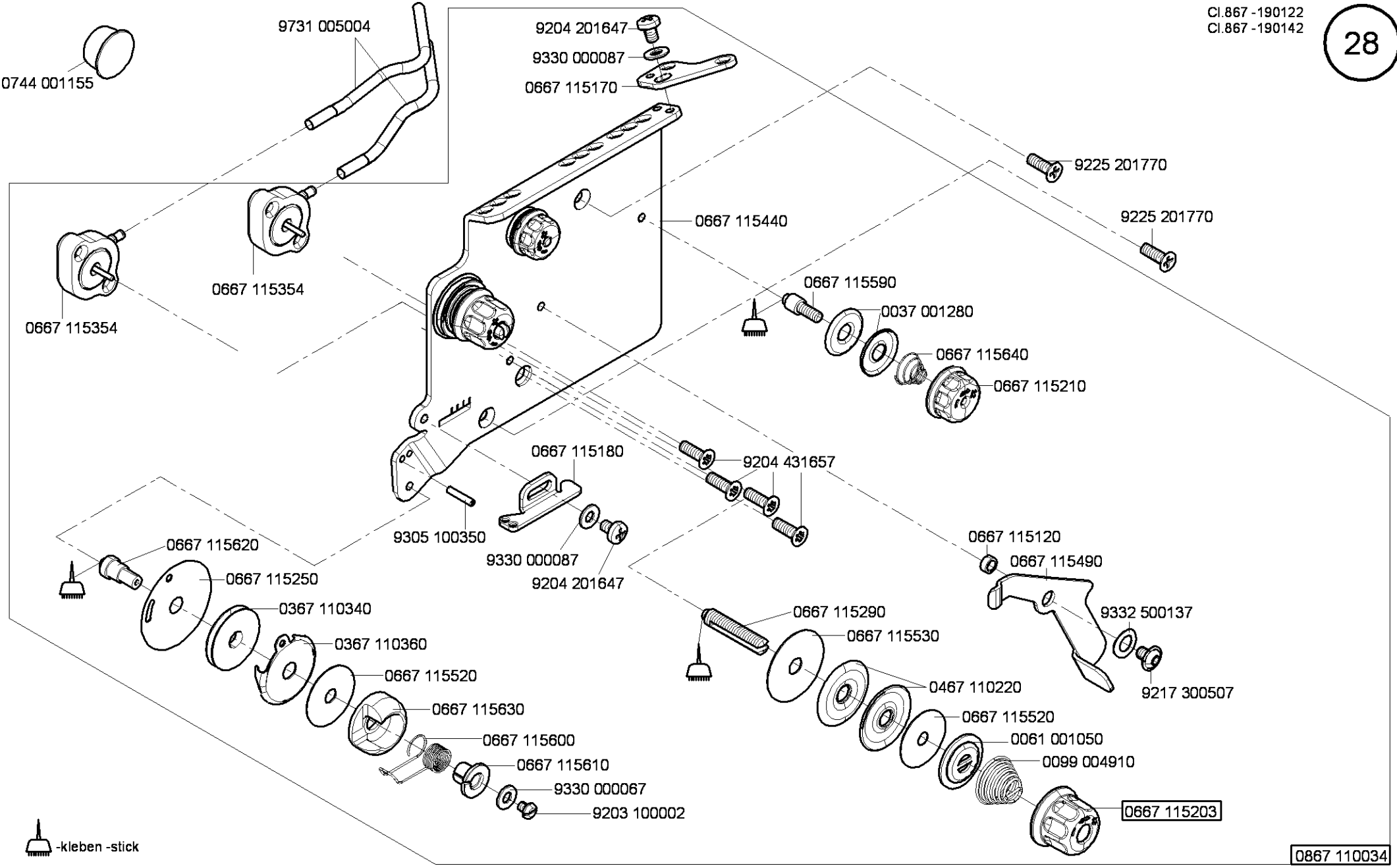

 -kleben -stick

0667 110034

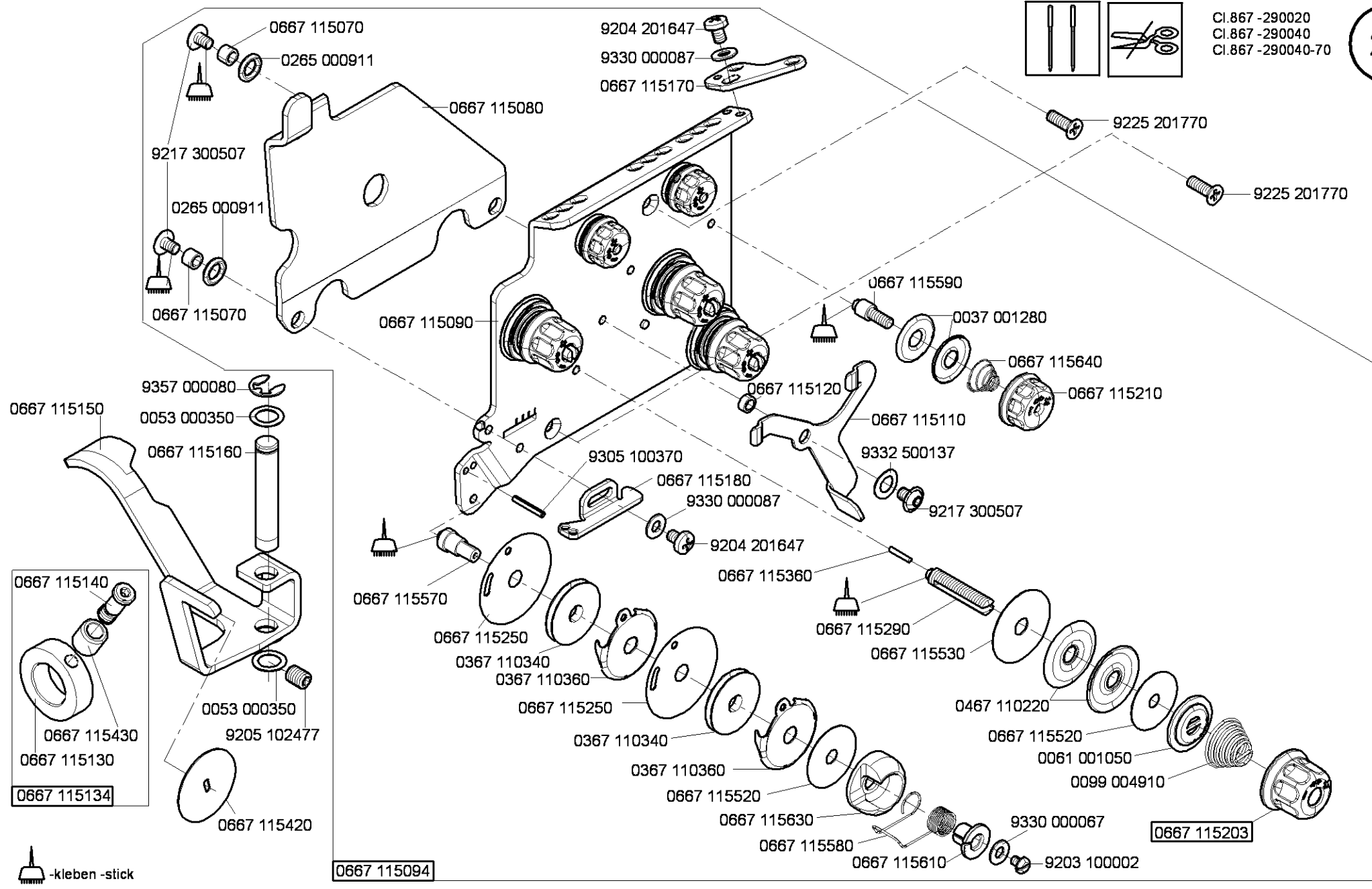
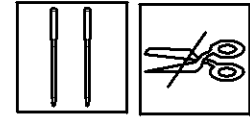

-kleben -stick

CI.867 -290322
CI.867 -290342
CI.867 -290445
CI.867 -490322
CI.867 -290342-70

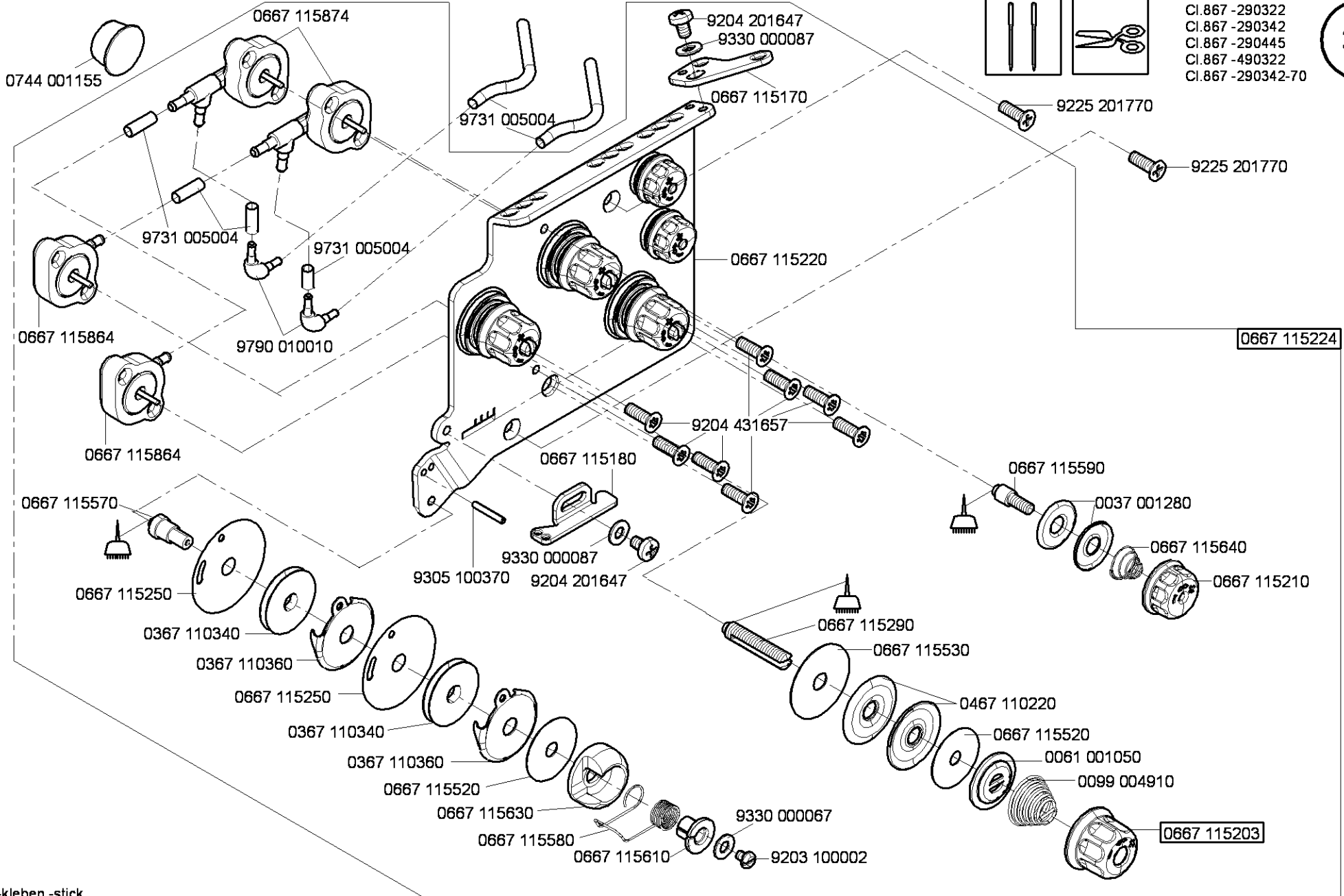
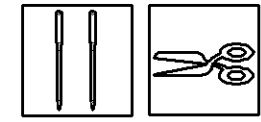

-kleben -stick

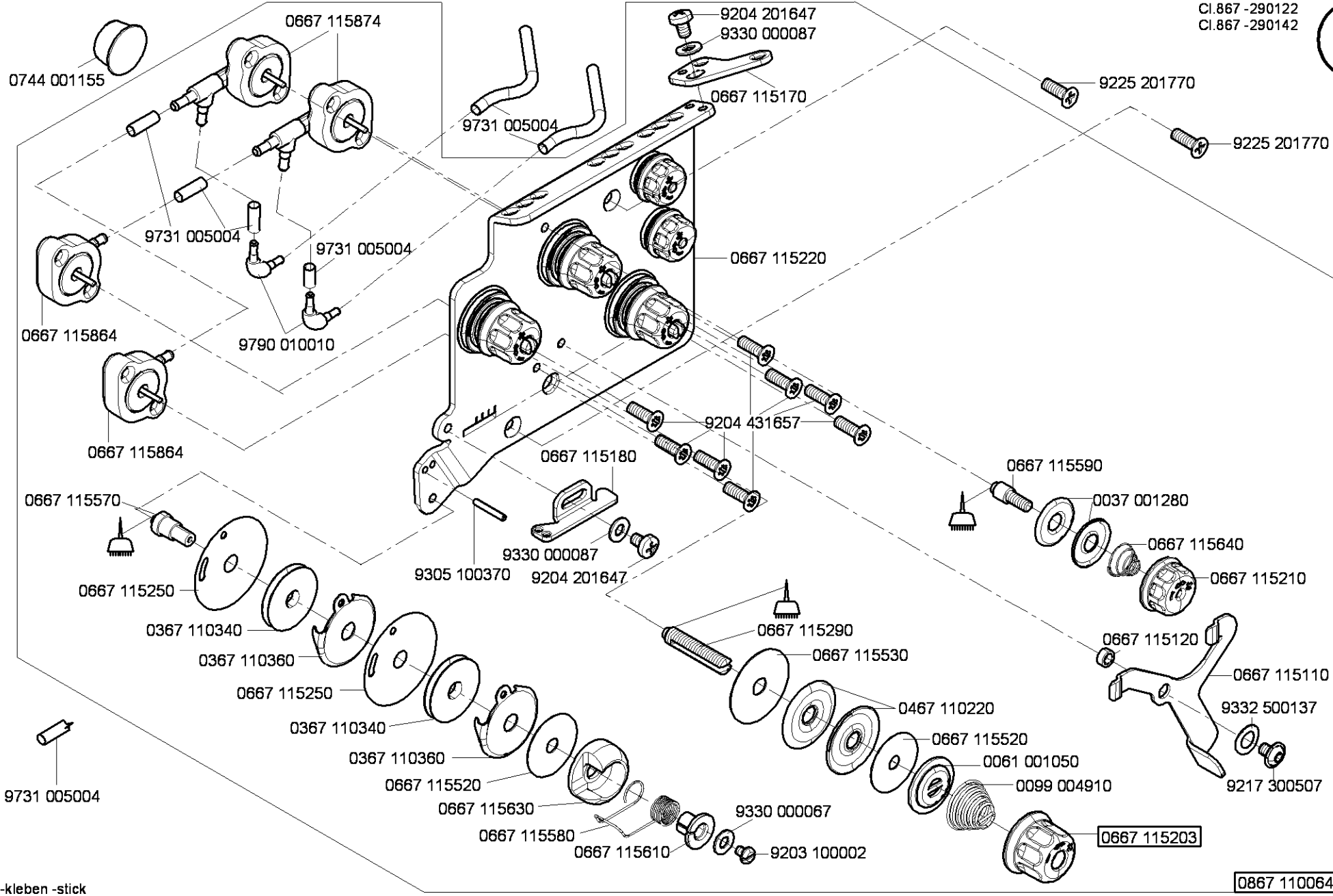

- CI.867 -190020
- CI.867 -190040
- CI.867 -190122
- CI.867 -190125
- CI.867 -190142
- CI.867 -190145
- CI.867 -290020
- CI.867 -290040
- CI.867 -290122
- CI.867 -290142
- CI.867 -190040-70
- CI.867 -290040-70

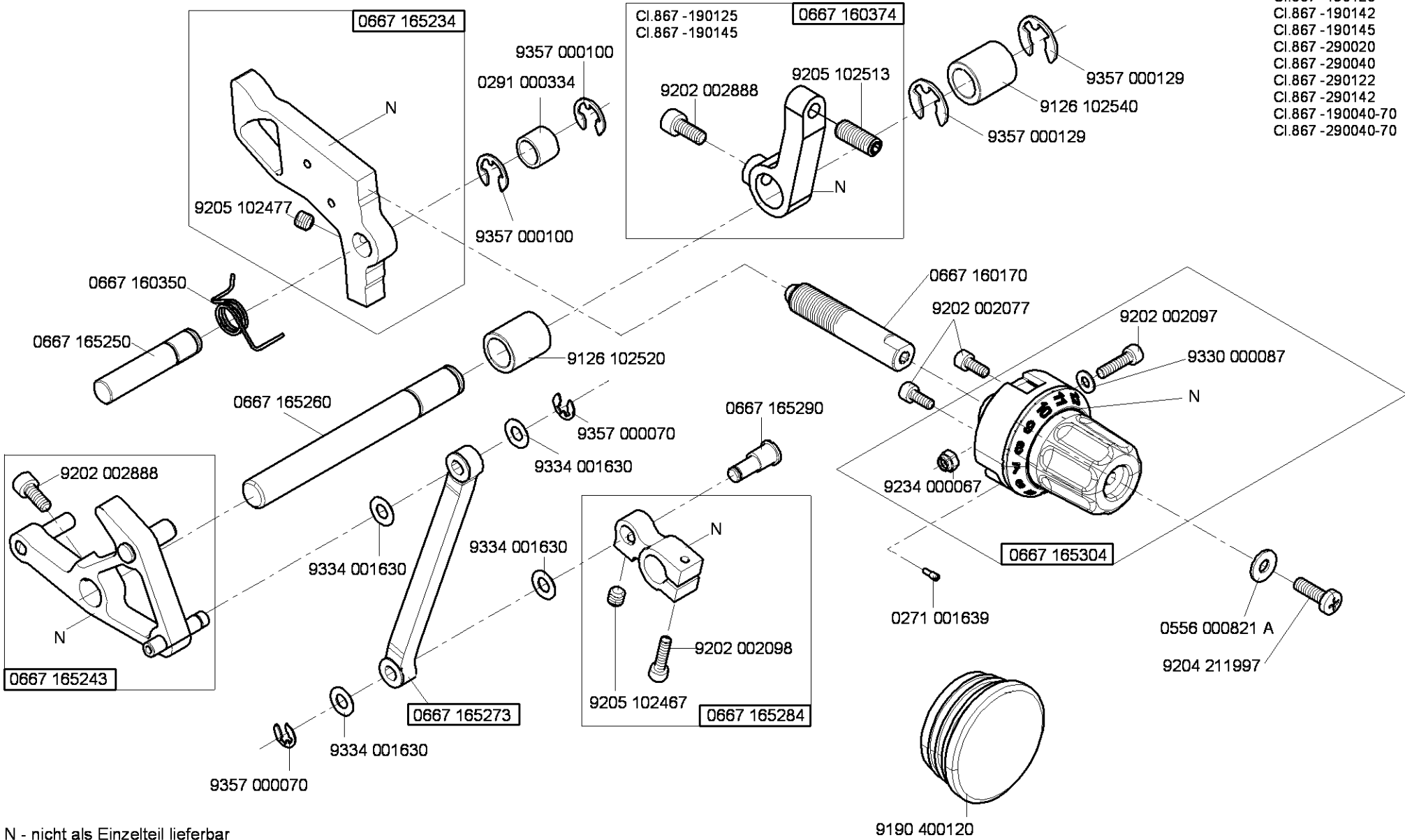

N - nicht als Einzelteil lieferbar
not available as separate part

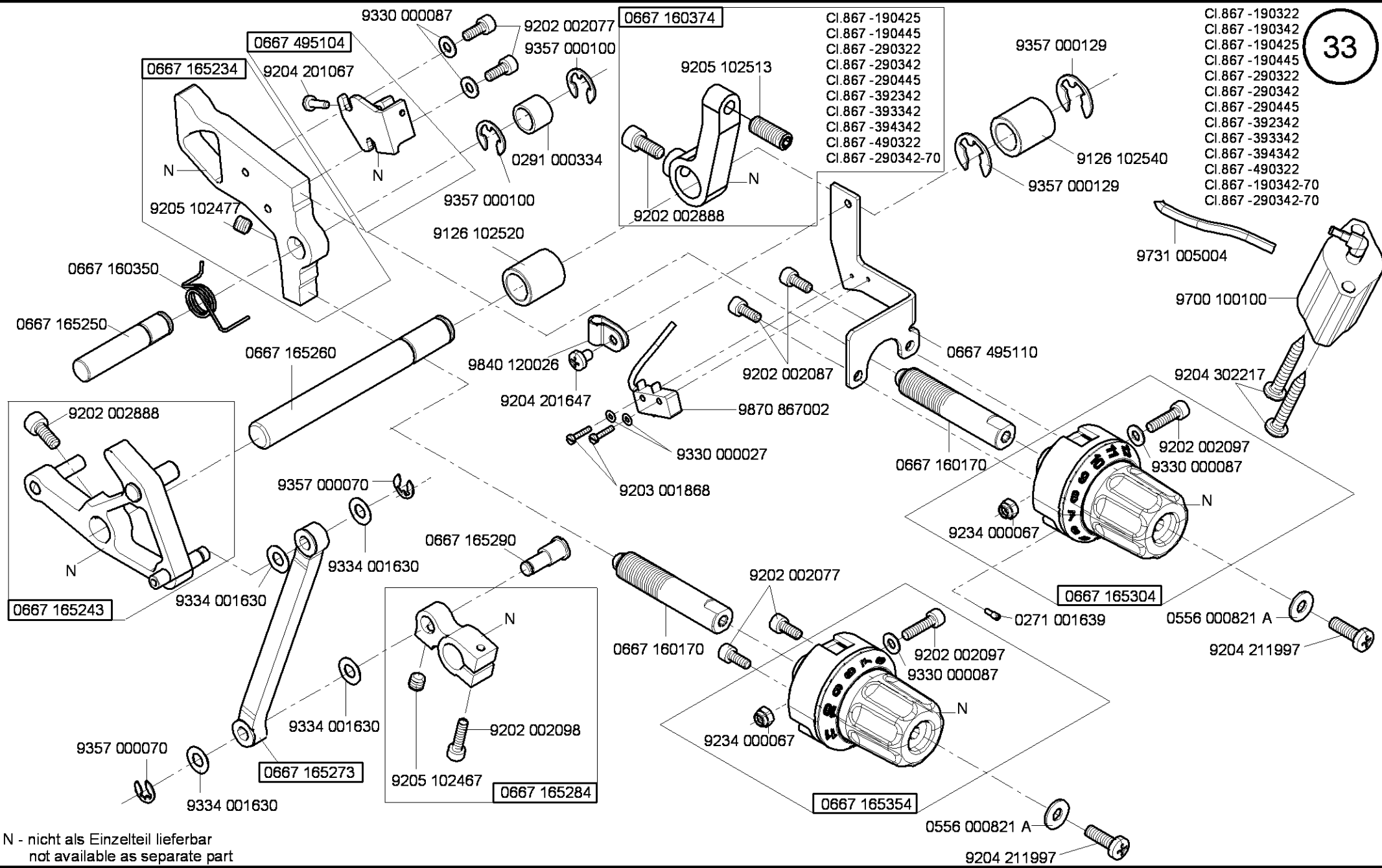

N - nicht als Einzelteil lieferbar
not available as separate part

- CI.867 -190020
- CI.867 -190040
- CI.867 -190322
- CI.867 -190342
- CI.867 -290020
- CI.867 -290040
- CI.867 -290322
- CI.867 -290342
- CI.867 -392342
- CI.867 -393342
- CI.867 -394342
- CI.867 -490322

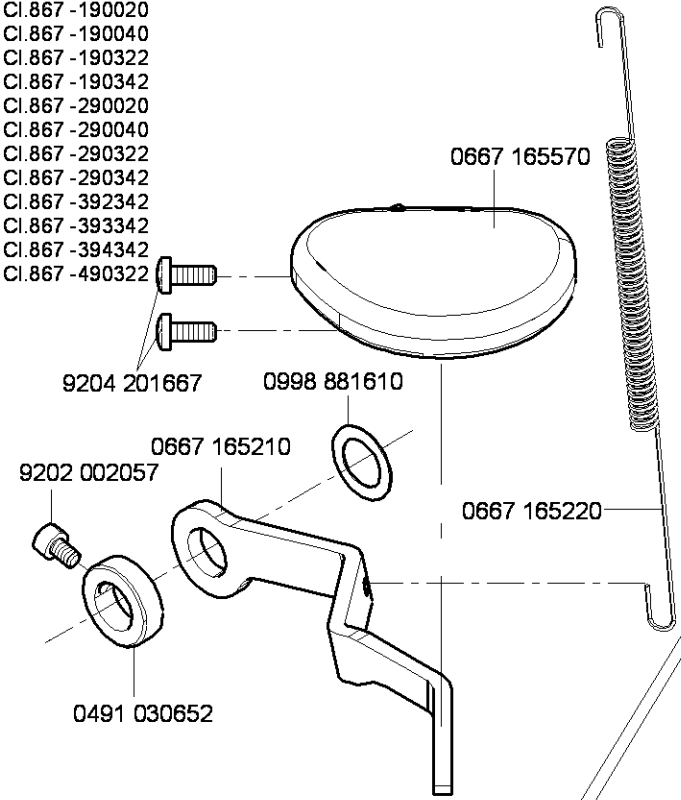

0867 590464

auf Wunsch
on request

- CI.867 -190122
- CI.867 -190142
- CI.867 -290122
- CI.867 -290142



0667 165700

- CI.867 -190122
- CI.867 -190125
- CI.867 -190142
- CI.867 -190145
- CI.867 -190425
- CI.867 -190445
- CI.867 -290122
- CI.867 -290142
- CI.867 -290445

- CI.867 -190122
- CI.867 -190125
- CI.867 -190142
- CI.867 -190145
- CI.867 -190322
- CI.867 -190342
- CI.867 -190425
- CI.867 -190445
- CI.867 -290122
- CI.867 -290142
- CI.867 -290322
- CI.867 -290342
- CI.867 -290445
- CI.867 -392342
- CI.867 -393342
- CI.867 -394342
- CI.867 -490322
- CI.867 -190342-70
- CI.867 -290342-70

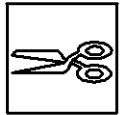
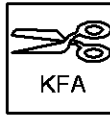
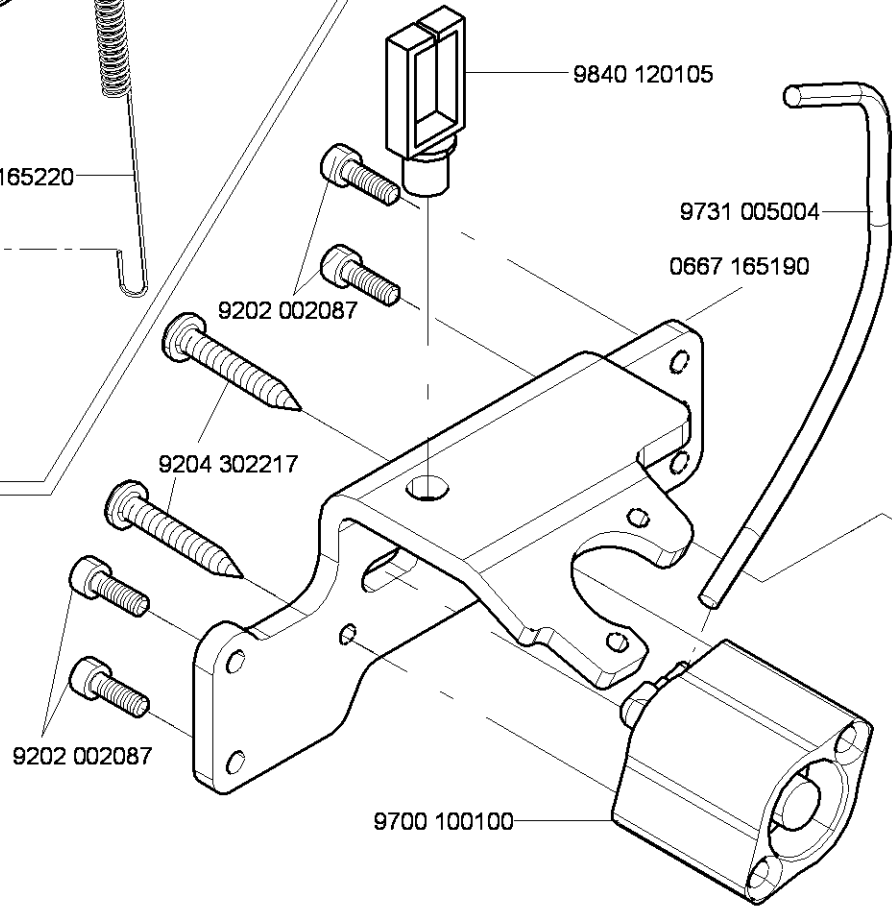
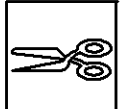

- CI.867 -190125
- CI.867 -190145
- CI.867 -190425
- CI.867 -190445
- CI.867 -290122
- CI.867 -290142
- CI.867 -290322
- CI.867 -290342
- CI.867 -290445
- CI.867 -392342
- CI.867 -393342
- CI.867 -394342
- CI.867 -490322
- CI.867 -290342-70

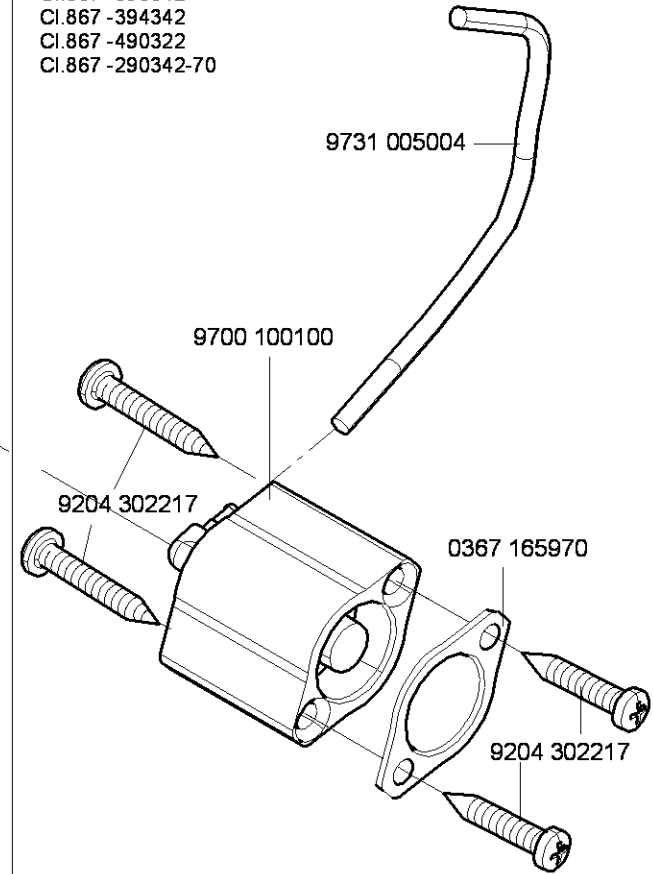

CI.867 -190040-70
CI.867 -190342-70
CI.867 -290040-70
CI.867 -290342-70

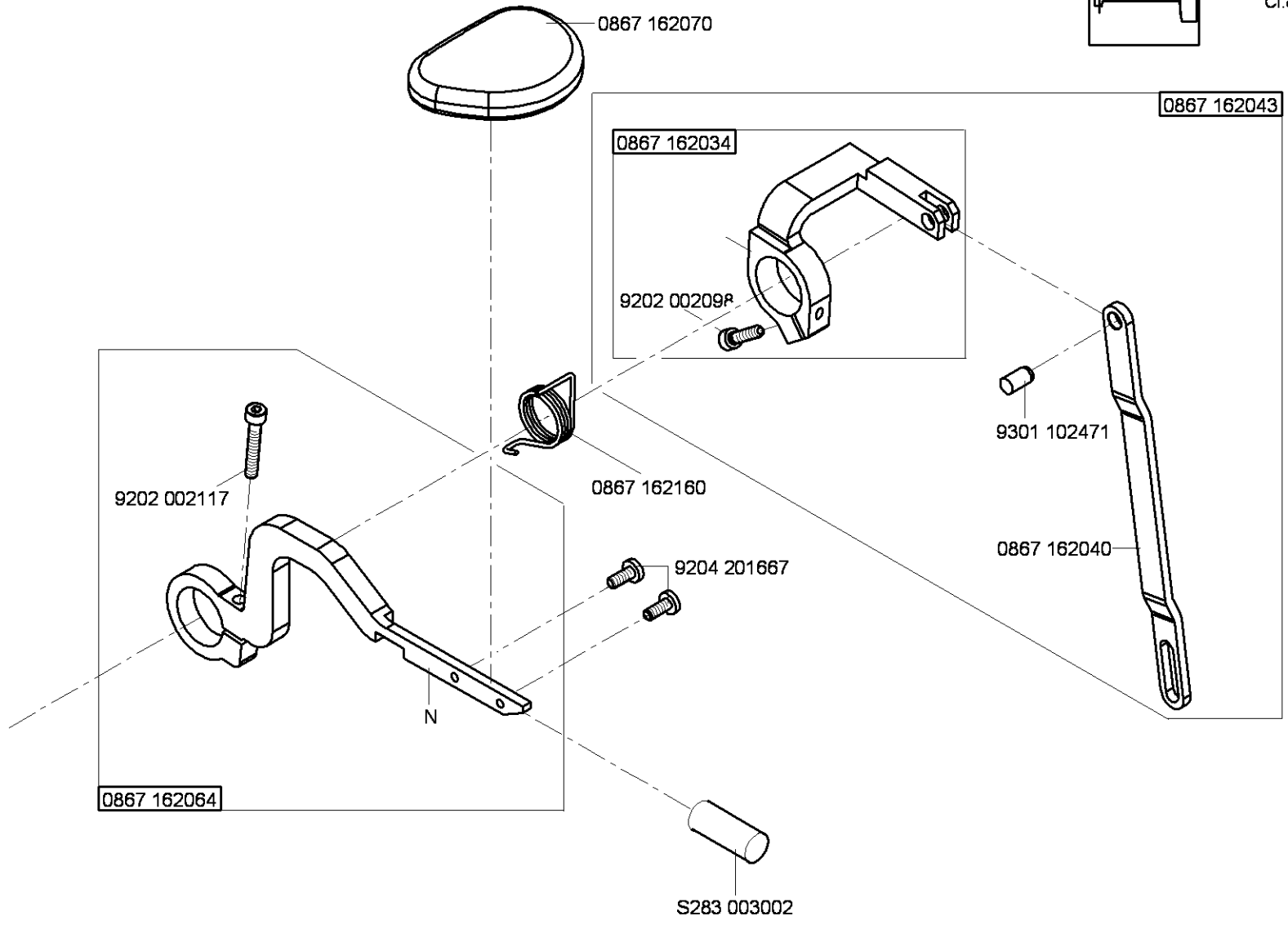
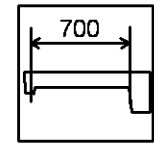

9880 867107 9880 867101

9199 000004

9850 867000

9203 100002

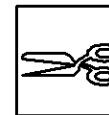

CI.867 -190322
CI.867 -190342
CI.867 -190342-70

36

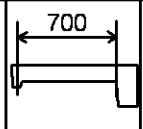

N

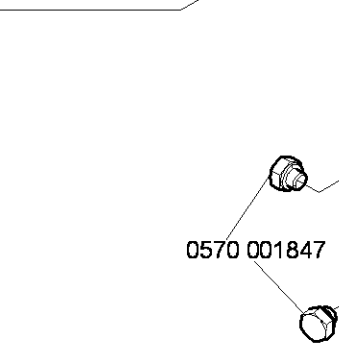
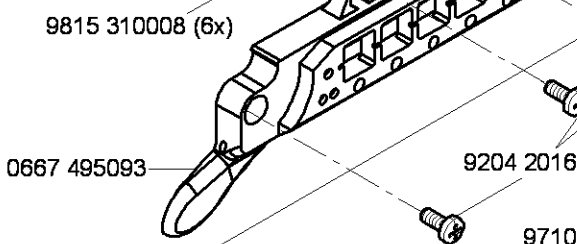
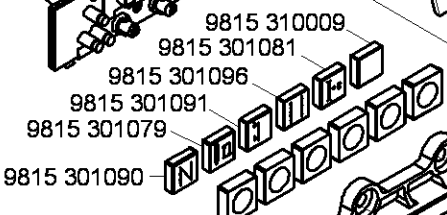
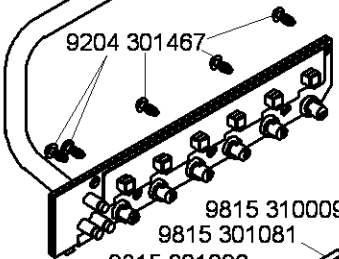

N - nicht als Einzelteil lieferbar
not available as separate part

9204 301467

9204 201667

0891 003342

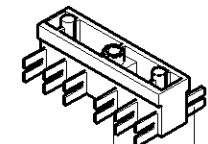

9204 201667

9825 550001

9790 200000



9830 501010

0667 495120

9204 201667

9790 201000

0570 001847

0667 495290

9204 201667

9710 920012

9710 982003

9710 900037

9710 061200

9204 200517

9710 900011

9204 200447

9731 005004

CI. 867

Ausgabe/Edition 1.2010

9880 867107 9880 867101

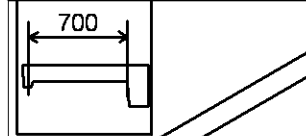

N

9204 301467

9815 310009

9815 301081

9815 301096

9815 301091

9815 301079

9815 301090

9815 310008 (6x)

0667 495093

9204 201667

9710 920012

9790 201000

9710 982003

9710 900037

9710 061200 (7x)

9204 200517 (14x)

9790 200000

9731 005004

9850 867000

9199 000004

9204 301467

9830 501010

0667 495120

9204 201667

9204 301467

9830 501010

0667 495120

9204 201667

9204 201667

9203 100002

0891 003342

9204 201667

9204 201667

9204 201667

9204 201667

9204 201667

9204 201667

9204 201667

9204 201667

9204 201667

9204 201667

9204 201667

9204 201667

9204 201667

9204 201667

9204 201667

9204 201667

9204 201667

9204 201667

9204 201667

9204 201667

9204 201667

9204 201667

9204 201667

9204 201667

9204 201667

9204 201667

9204 201667

9204 201667

9204 201667

9204 201667

9204 201667

9204 201667

9204 201667

9204 201667

9204 201667

9204 201667

9204 201667

9204 201667

9204 201667

9204 201667

9204 201667

9204 201667

9204 201667

9204 201667

9204 201667

9204 201667

9204 201667

9204 201667

9204 201667

9204 201667

9204 201667

9204 201667

9204 201667

9204 201667

9204 201667

9204 201667

9204 201667

9204 201667

9204 201667

9204 201667

9204 201667

9204 201667

9204 201667

9204 201667

9204 201667

9204 201667

9204 201667

9204 201667

9204 201667

9204 201667

9204 201667

9204 201667

9204 201667

9204 201667

9204 201667

9204 201667

9204 201667

9204 201667

9204 201667

9204 201667

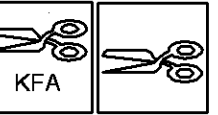

- CI.867 -190445
- CI.867 -290322
- CI.867 -290342
- CI.867 -290445
- CI.867 -392342
- CI.867 -393342
- CI.867 -394342
- CI.867 -490322
- CI.867 -290342-70

0891 003342

9204 201667

9204 201667

9204 201667

9204 201667

9204 201667

9204 201667

9204 201667

9204 201667

9204 201667

9204 201667

9204 201667

9204 201667

9204 201667

9204 201667

9204 201667

9204 201667

9204 201667

9204 201667

9204 201667

9204 201667

9204 201667

9204 201667

9204 201667

9204 201667

9204 201667

9204 201667

9204 201667

9204 201667

N - nicht als Einzelteil lieferbar
not available as separate part

9880 867110

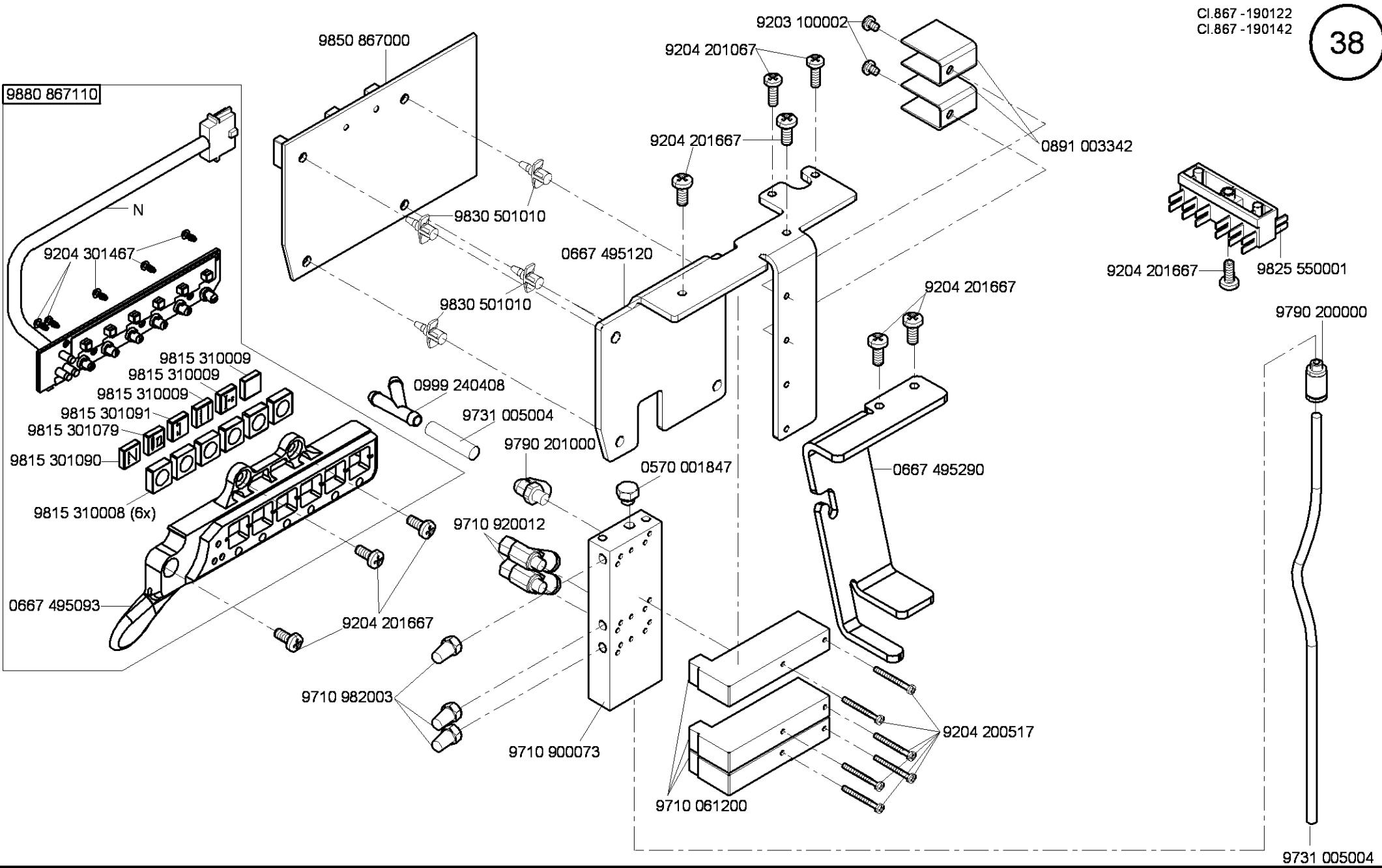

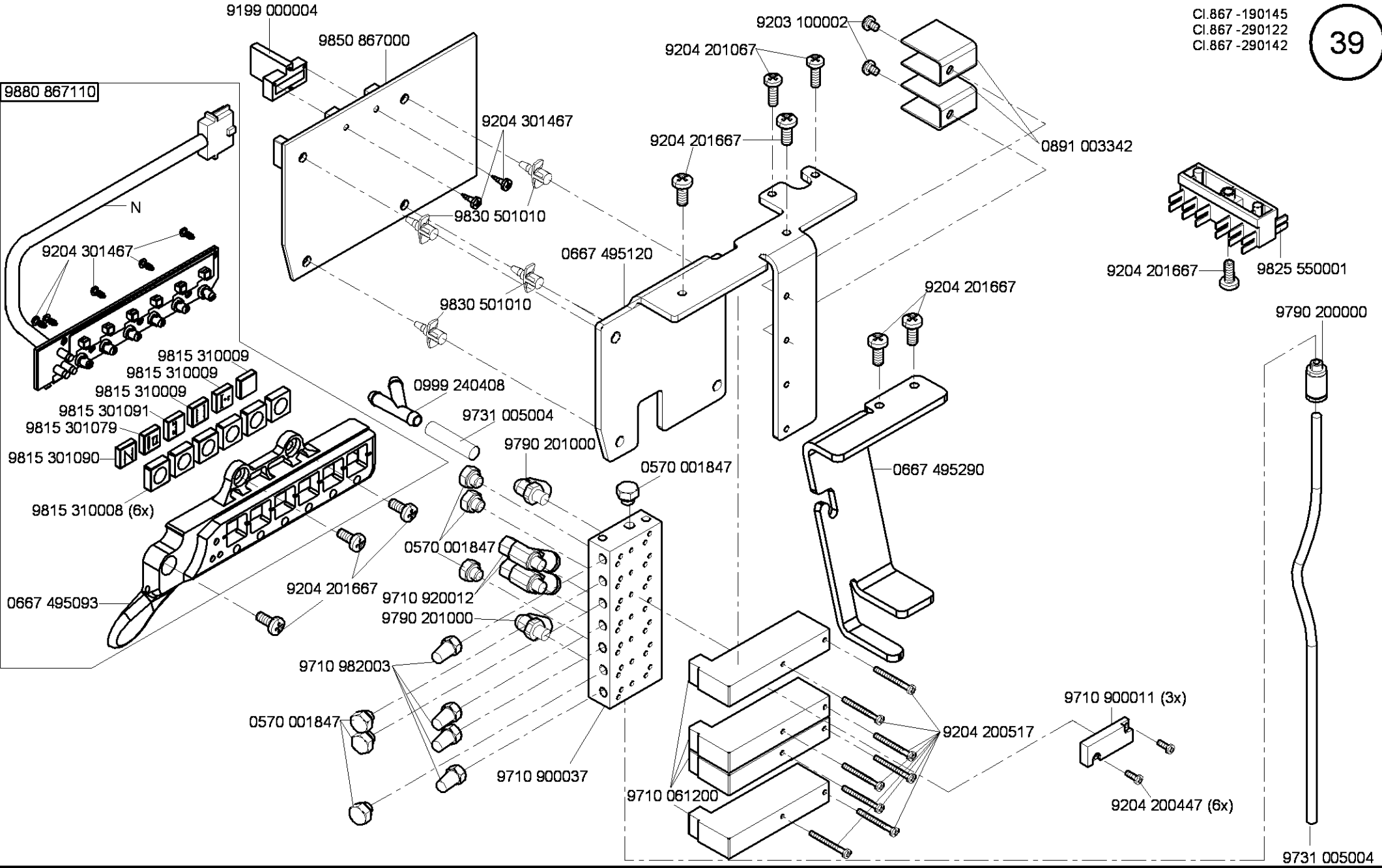

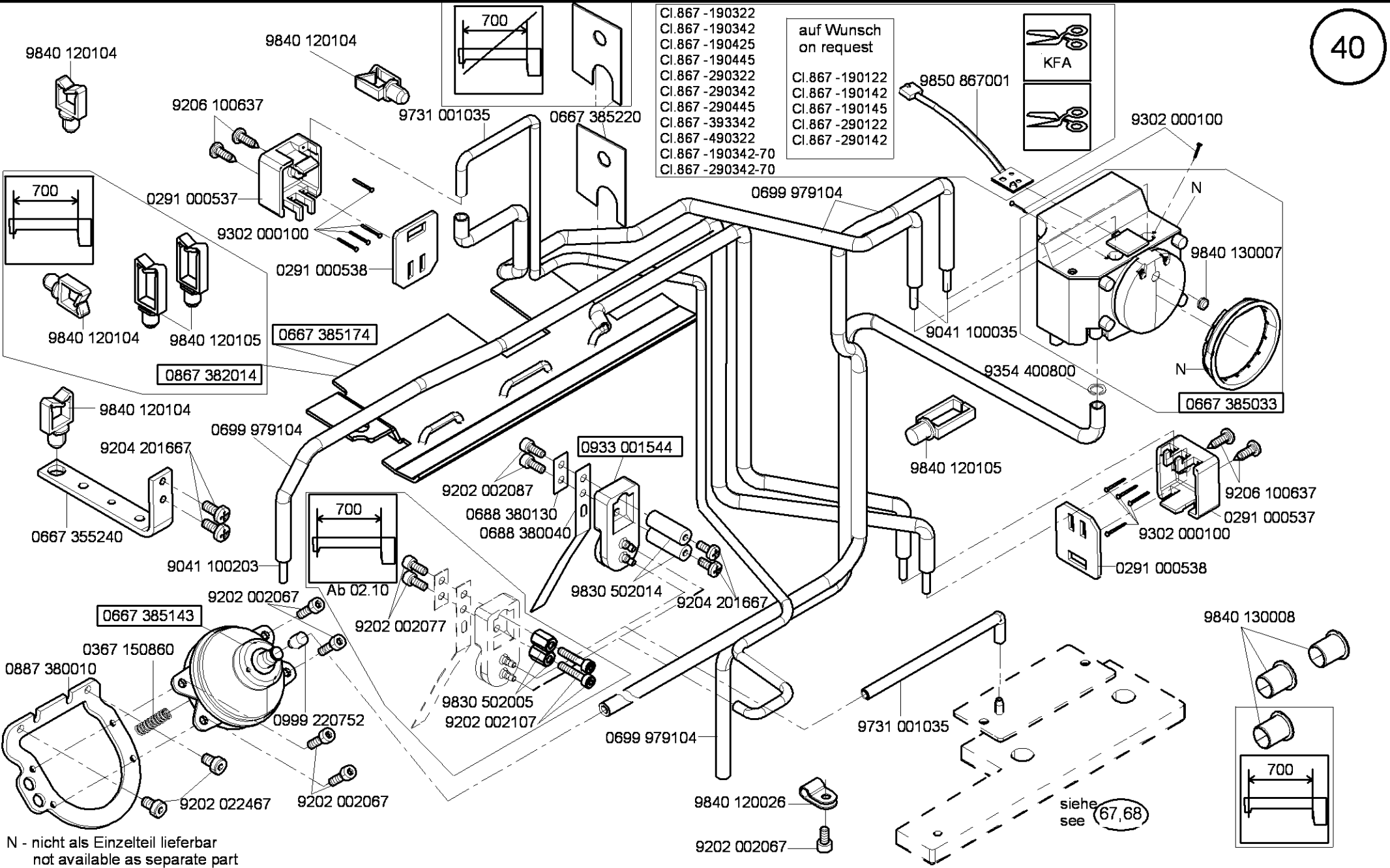

CI.867 -190322
 CI.867 -190342
 CI.867 -190425
 CI.867 -190445
 CI.867 -290322
 CI.867 -290342
 CI.867 -290445
 CI.867 -393342
 CI.867 -490322
 CI.867 -190342-70
 CI.867 -290342-70

auf Wunsch
 on request

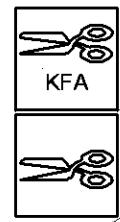

N - nicht als Einzelteil lieferbar
 not available as separate part

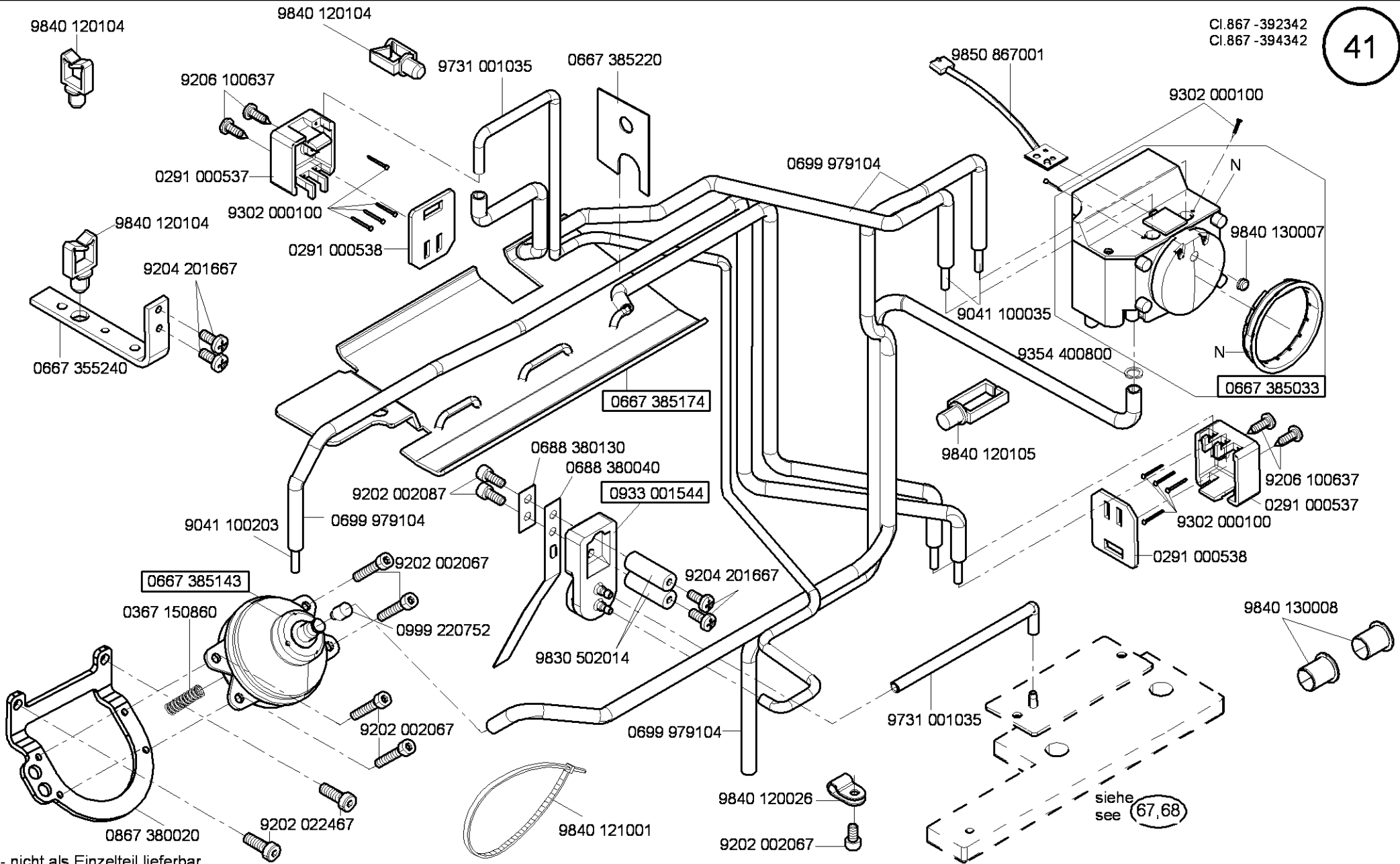

N - nicht als Einzelteil lieferbar
not available as separate part

siehe see (67,68)

9880 867102

- 0667 495304
- 9840 120003 (8x)
- 9840 123003 (8x)
- 9840 121001 (5x)
- 9840 133013
- 9840 133012
- 9840 135012
- 9840 132015
- 9840 120026 (2x)
- 9202 002077 (3x)
- 9207 170437 (2x)
- 9840 104001 (2x)

- CI.867 -190322
- CI.867 -190342
- CI.867 -190425
- CI.867 -190445
- CI.867 -290322
- CI.867 -290342
- CI.867 -290445

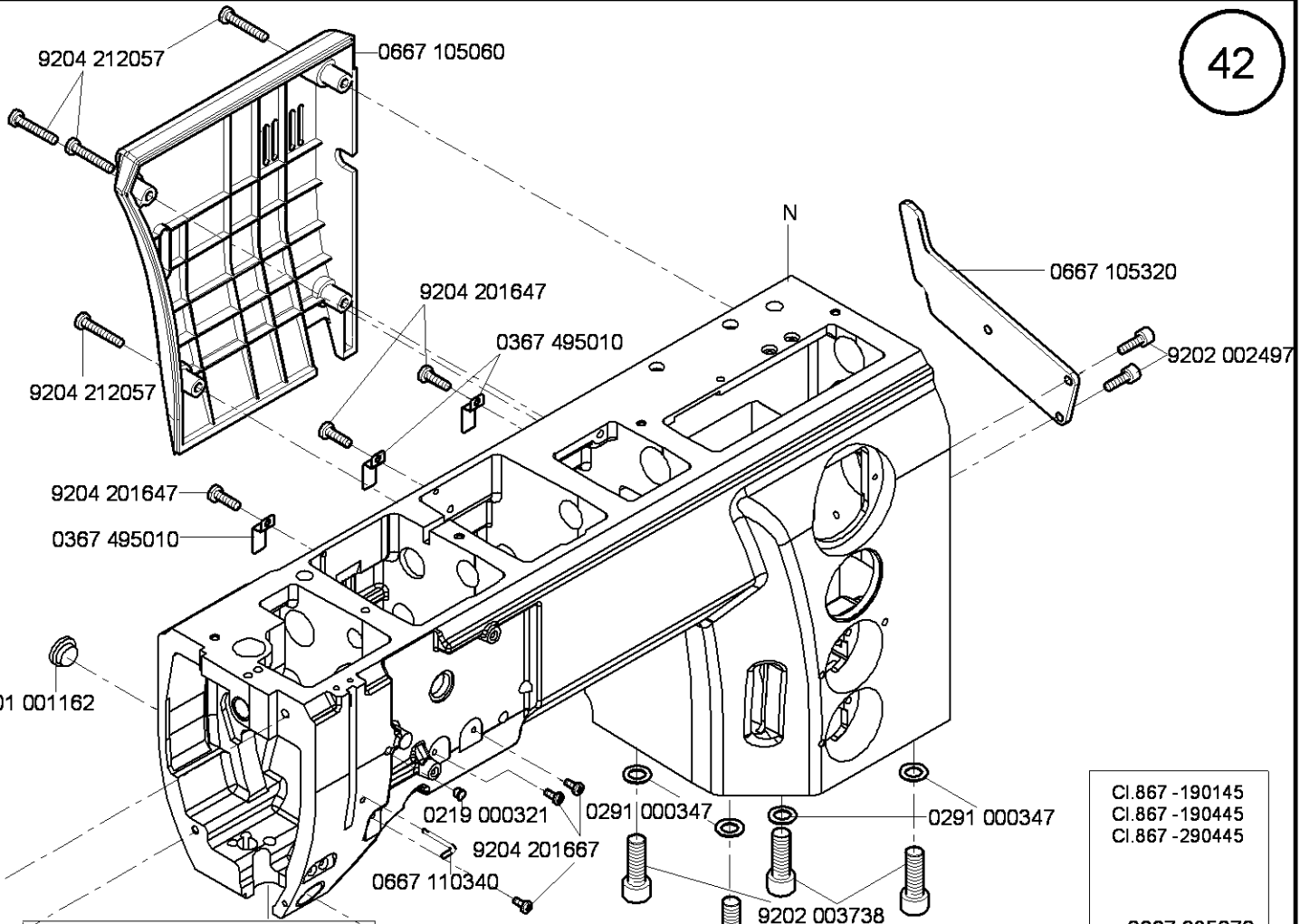

0667 105144

0667 105164

CI.867 -392342

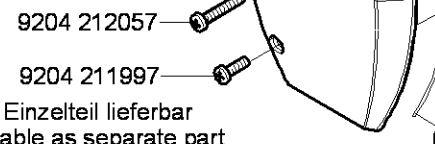

N - nicht als Einzelteil lieferbar
not available as separate part

0699 989250

0667 385180
0667 105120

- CI.867 -190020
- CI.867 -190040
- CI.867 -190122
- CI.867 -190125
- CI.867 -190142
- CI.867 -190145
- CI.867 -290020
- CI.867 -290040
- CI.867 -290122
- CI.867 -290142

9202 002077

0911 000290

9205 101868
0667 115760
9225 201770
0667 115280

0667 115743
9225 201770
0911 000290
0667 115730
9205 101868
9820 110025

0667 385070
9202 100537

- CI.867 -190145
- CI.867 -190445
- CI.867 -290445

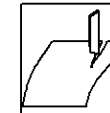

9880 867102

- 0667 495304
- 9840 120003 (8x)
- 9840 123003 (8x)
- 9840 121001 (5x)
- 9840 133013
- 9840 120026 (2x)
- 9840 133012
- 9202 002077 (3x)
- 9840 135012
- 9207 170437 (2x)
- 9840 132015
- 9840 104001 (2x)

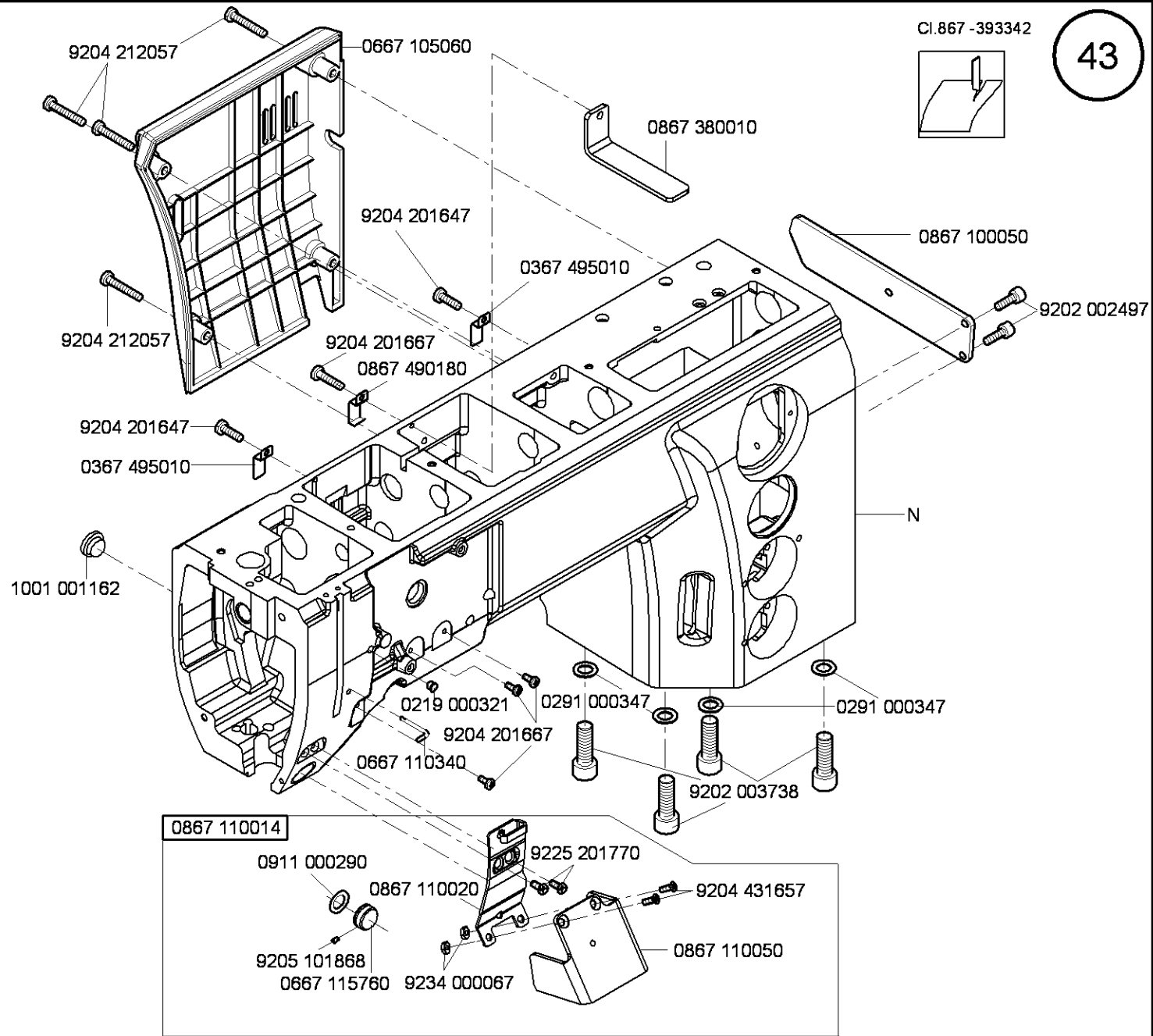

N - nicht als Einzelteil lieferbar
not available as separate part

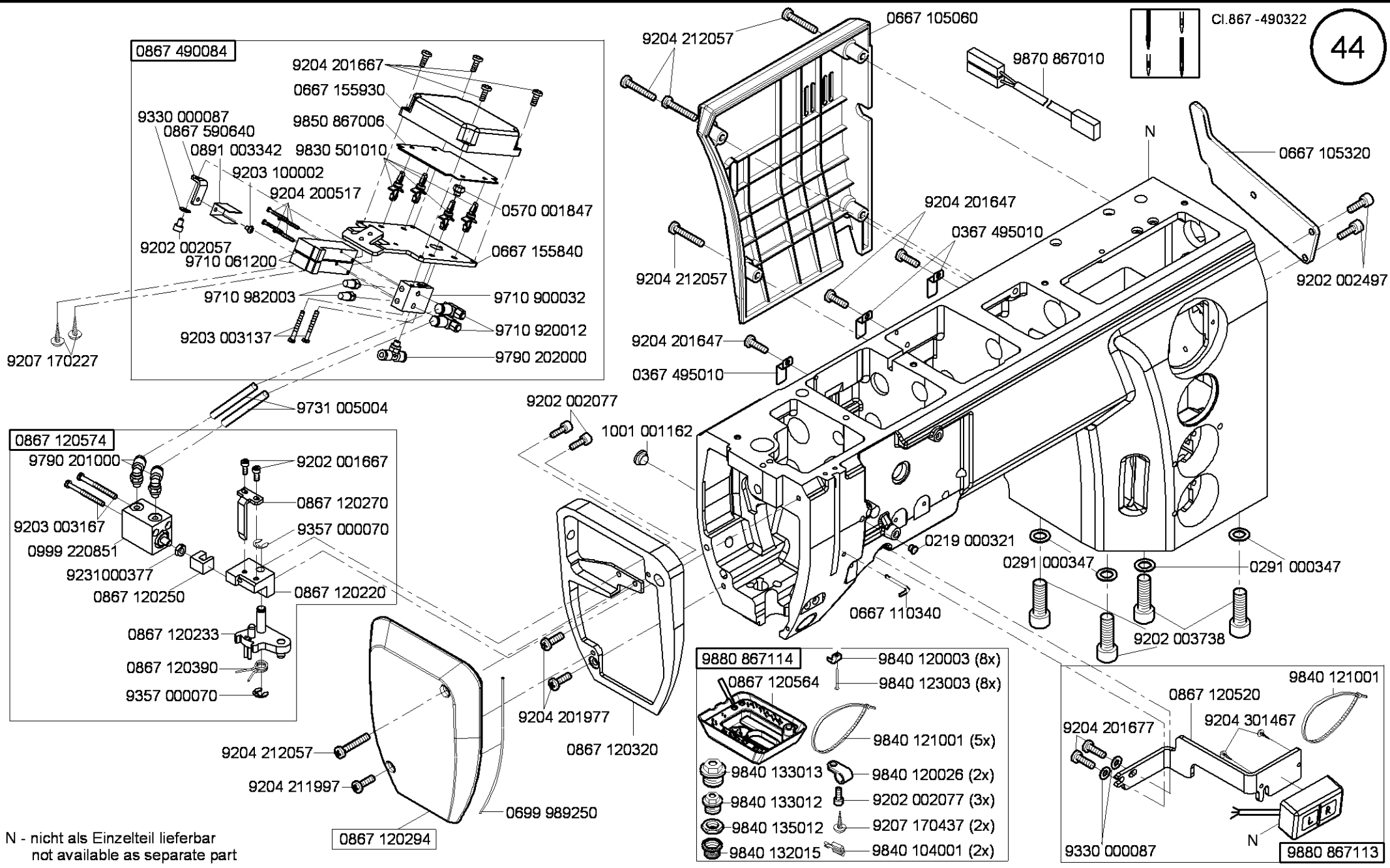

N - nicht als Einzelteil lieferbar
not available as separate part

9880 867102

CI.867 -190342-70

CI.867 -290342-70

0667 495304

9840 120003 (8x)

9840 123003 (8x)

9840 121001 (5x)

9840 133013

9840 120026 (2x)

9840 133012

9202 002077 (3x)

9840 135012

9207 170437 (2x)

9840 132015

9840 104001 (2x)

CI.867 -190040-70

CI.867 -290040-70

0667 385180

0667 105120

9202 002077

1001 001162

0699 989250

0667 105144

9204 212057

9204 211997

N - nicht als Einzelteil lieferbar
not available as separate part

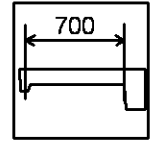
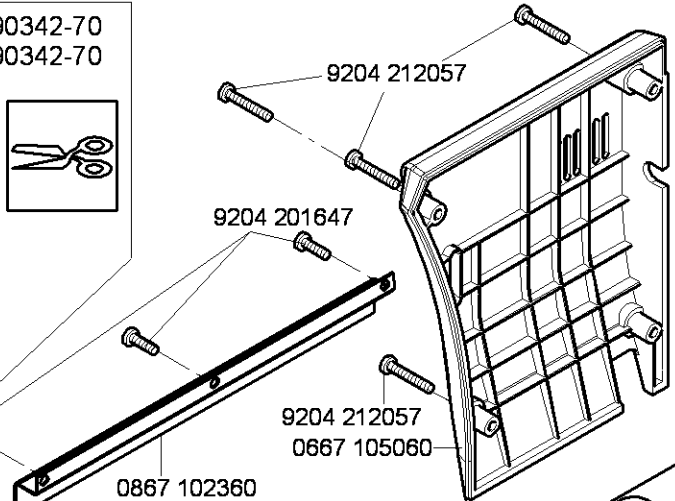

CI.867 -190040-70
CI.867 -190342-70
CI.867 -290040-70
CI.867 -290342-70

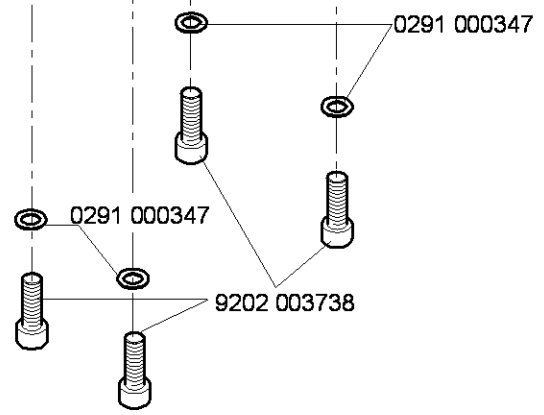
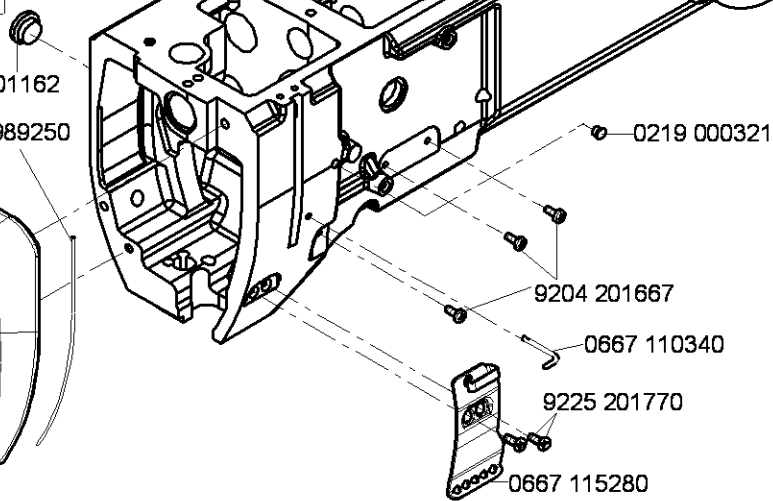
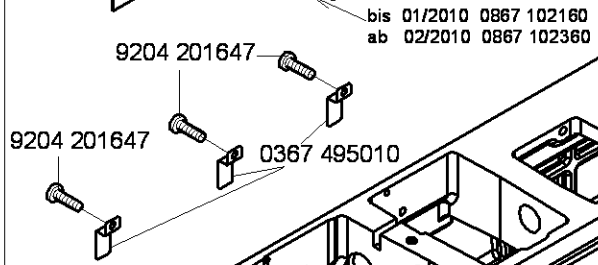

- CI.867 -190020
- CI.867 -190040
- CI.867 -190122
- CI.867 -190125
- CI.867 -190142
- CI.867 -190145
- CI.867 -290020
- CI.867 -290040
- CI.867 -290122
- CI.867 -290142

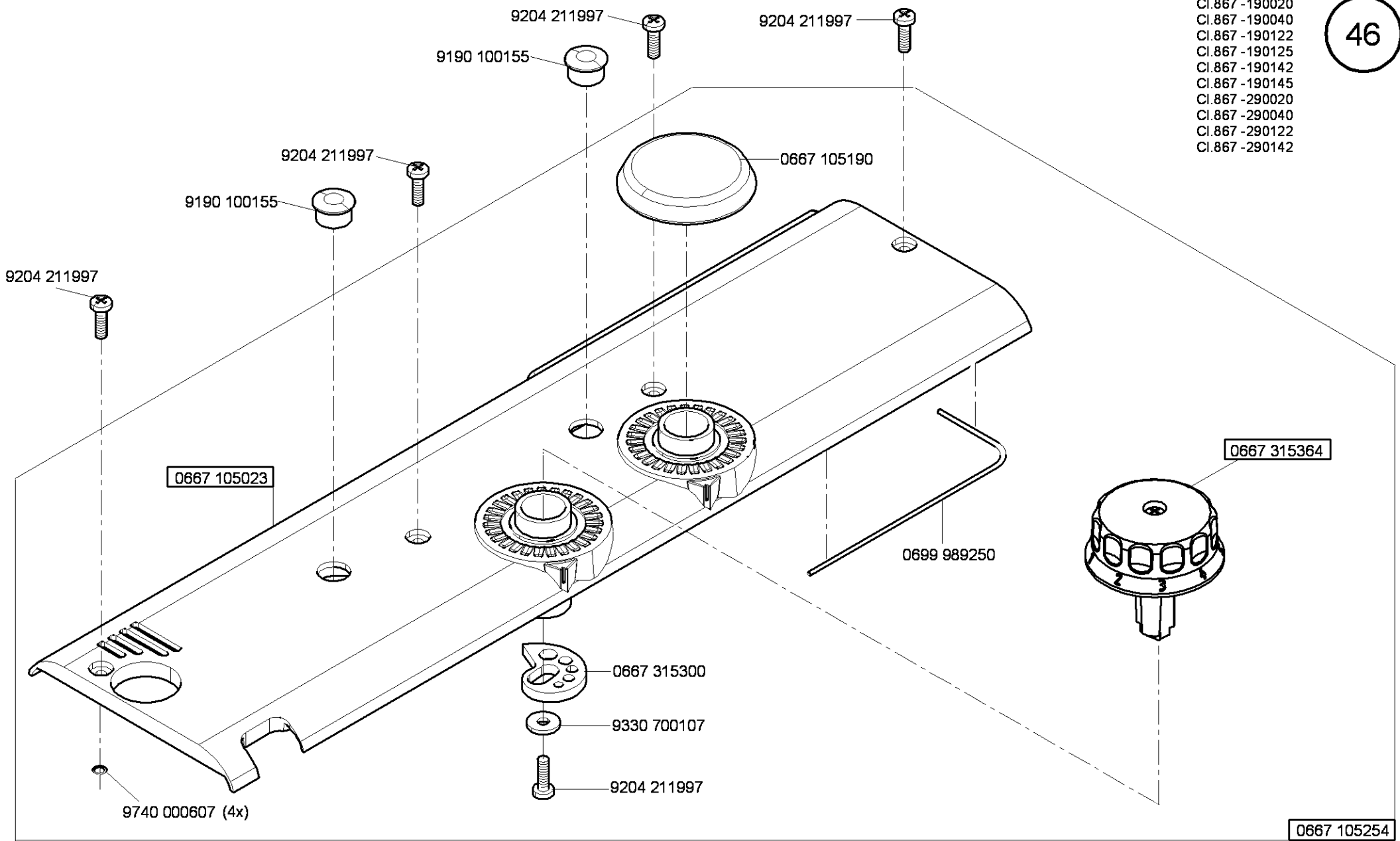

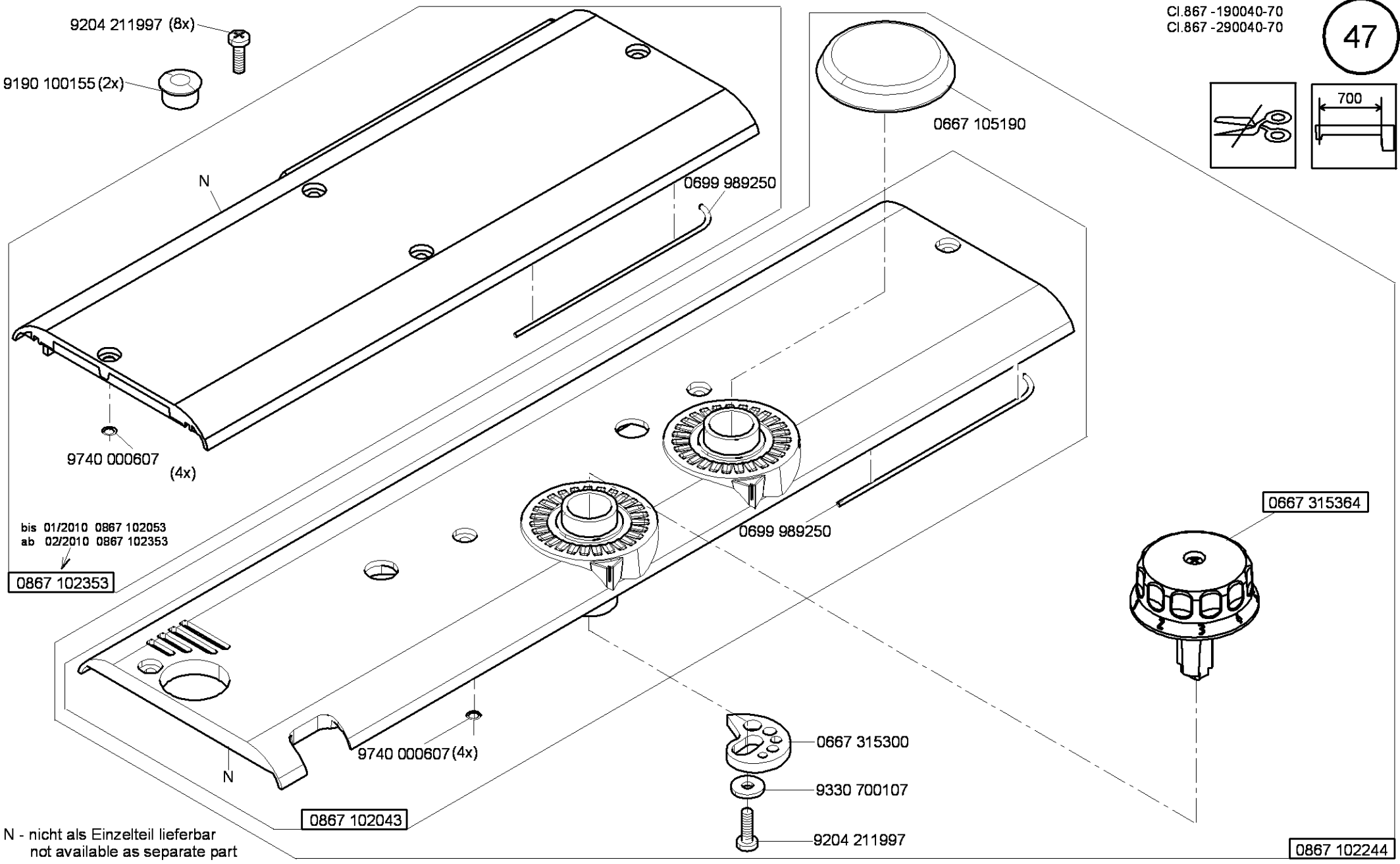
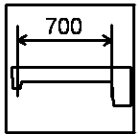
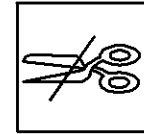

N - nicht als Einzelteil lieferbar
not available as separate part

- CI.867 -190322
- CI.867 -190342
- CI.867 -290322
- CI.867 -290342
- CI.867 -392342
- CI.867 -393342
- CI.867 -394342
- CI.867 -490322

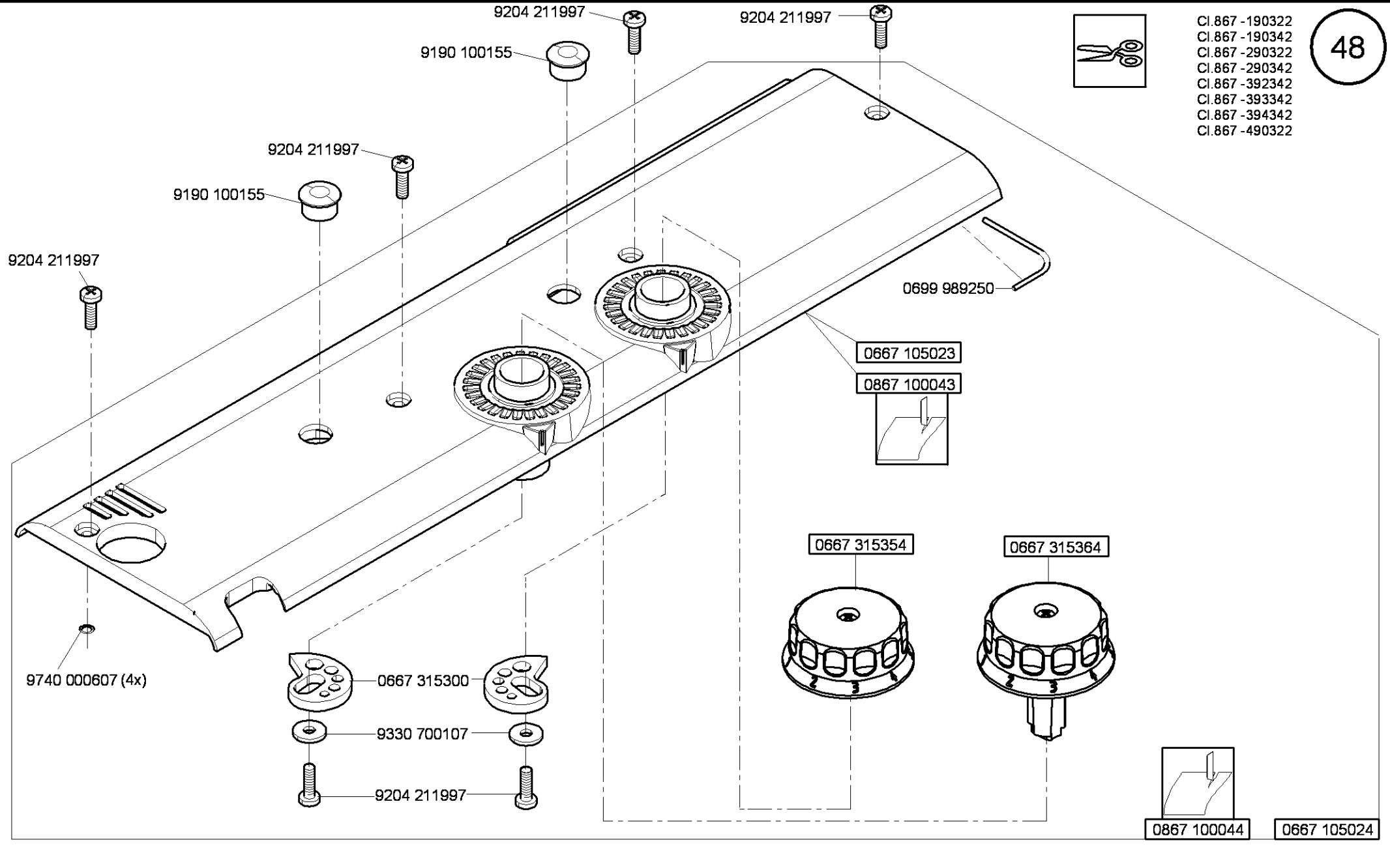
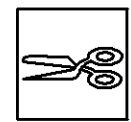

9204 211997 (8x)



9190 100155 (2x)



N

0699 989250

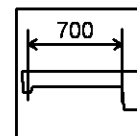
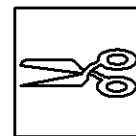

CI.867 -190342-70
CI.867 -290342-70

9740 000607 (4x)

bis 01/2010 0867 102053
ab 02/2010 0867 102353

0867 102353

0699 989250

0667 315354

0667 315364

9740 000607 (4x)

0867 102043

0667 315300

9330 700107

9204 211997

0867 102044

N - nicht als Einzelteil lieferbar
not available as separate part

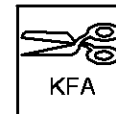

CI. 867 -190425
CI. 867 -190445
CI. 867 -290445

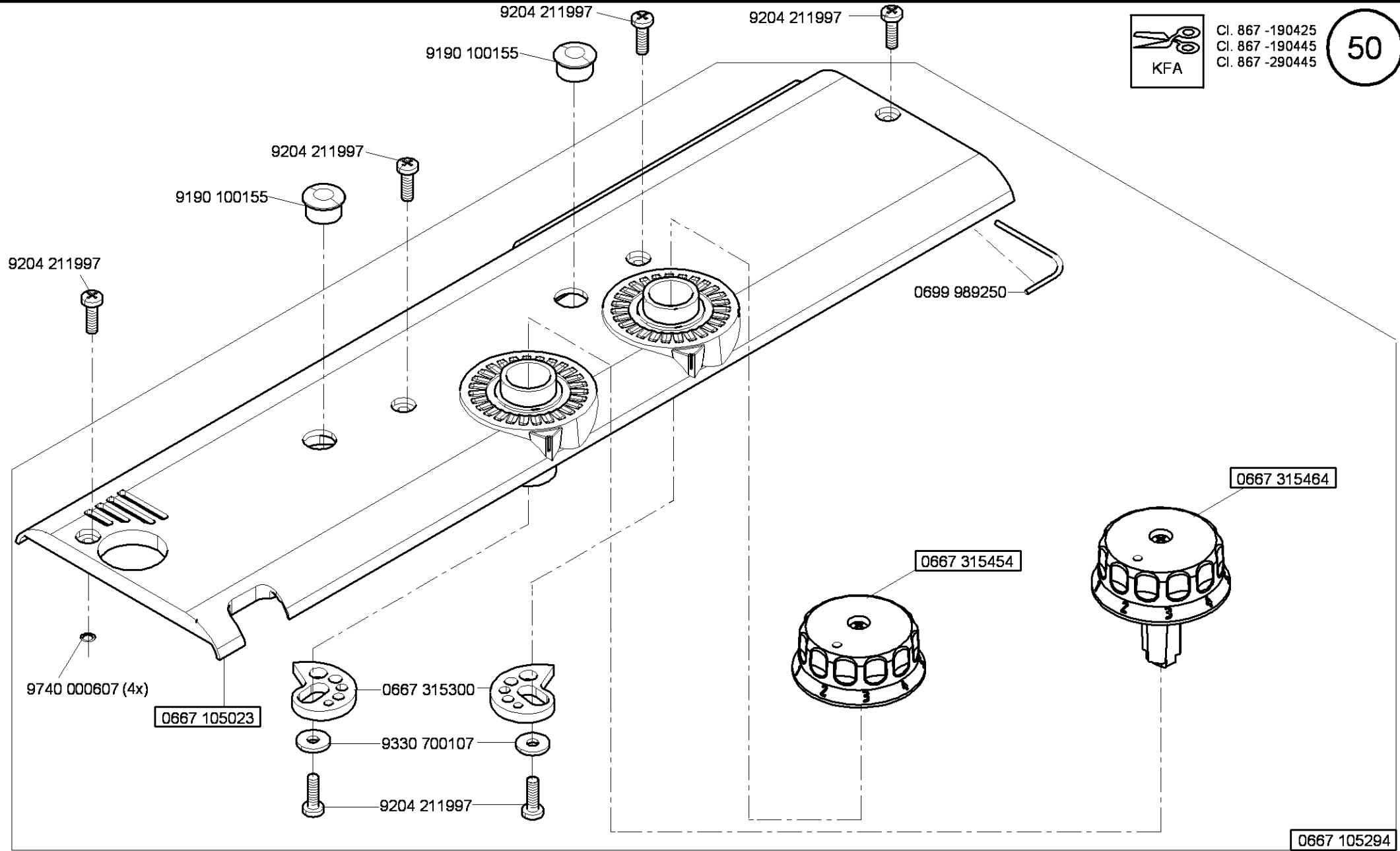

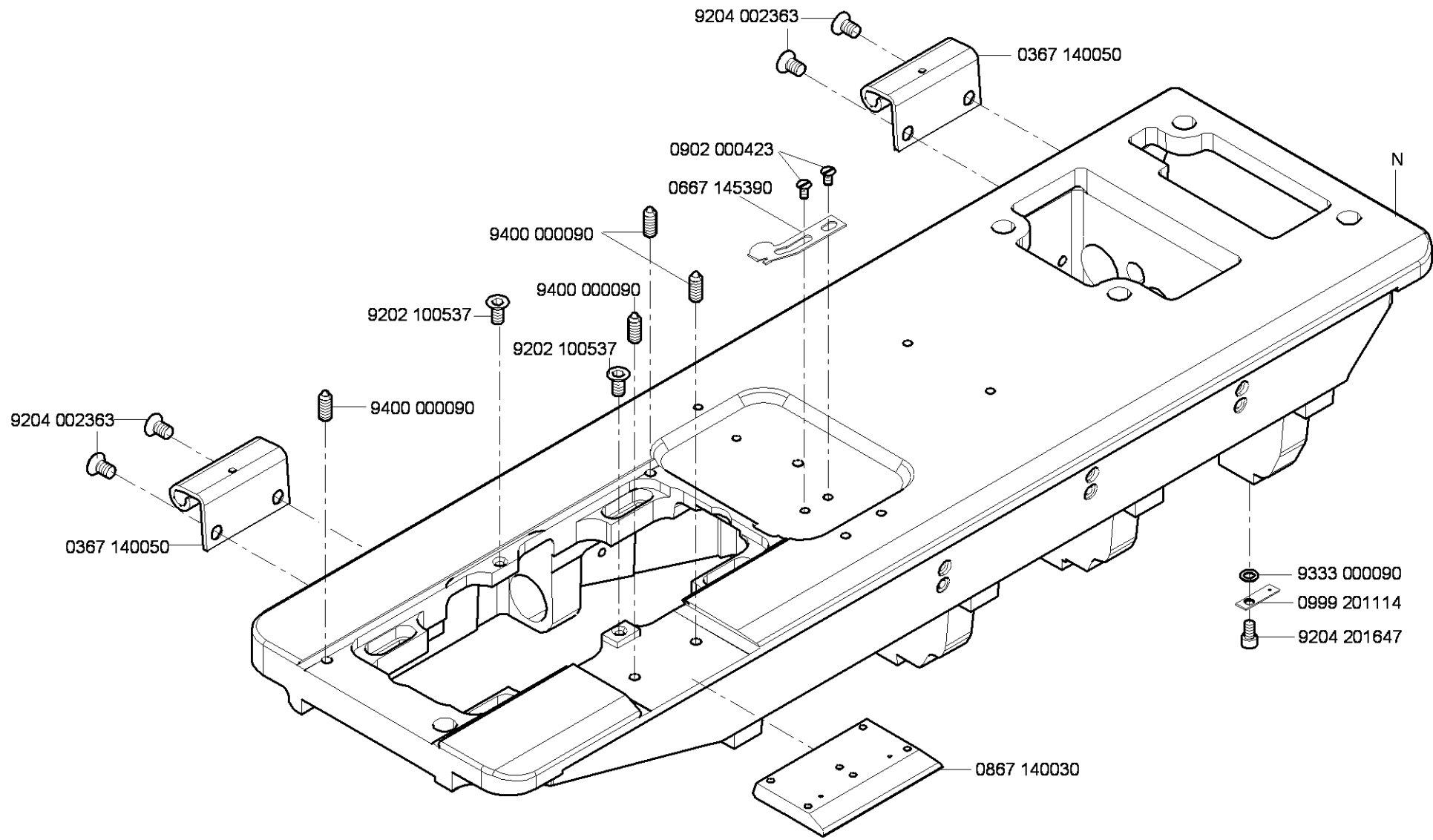

N - nicht als Einzelteil lieferbar
not available as separate part

Cl.867 -190040-70
Cl.867 -190342-70
Cl.867 -290040-70
Cl.867 -290342-70

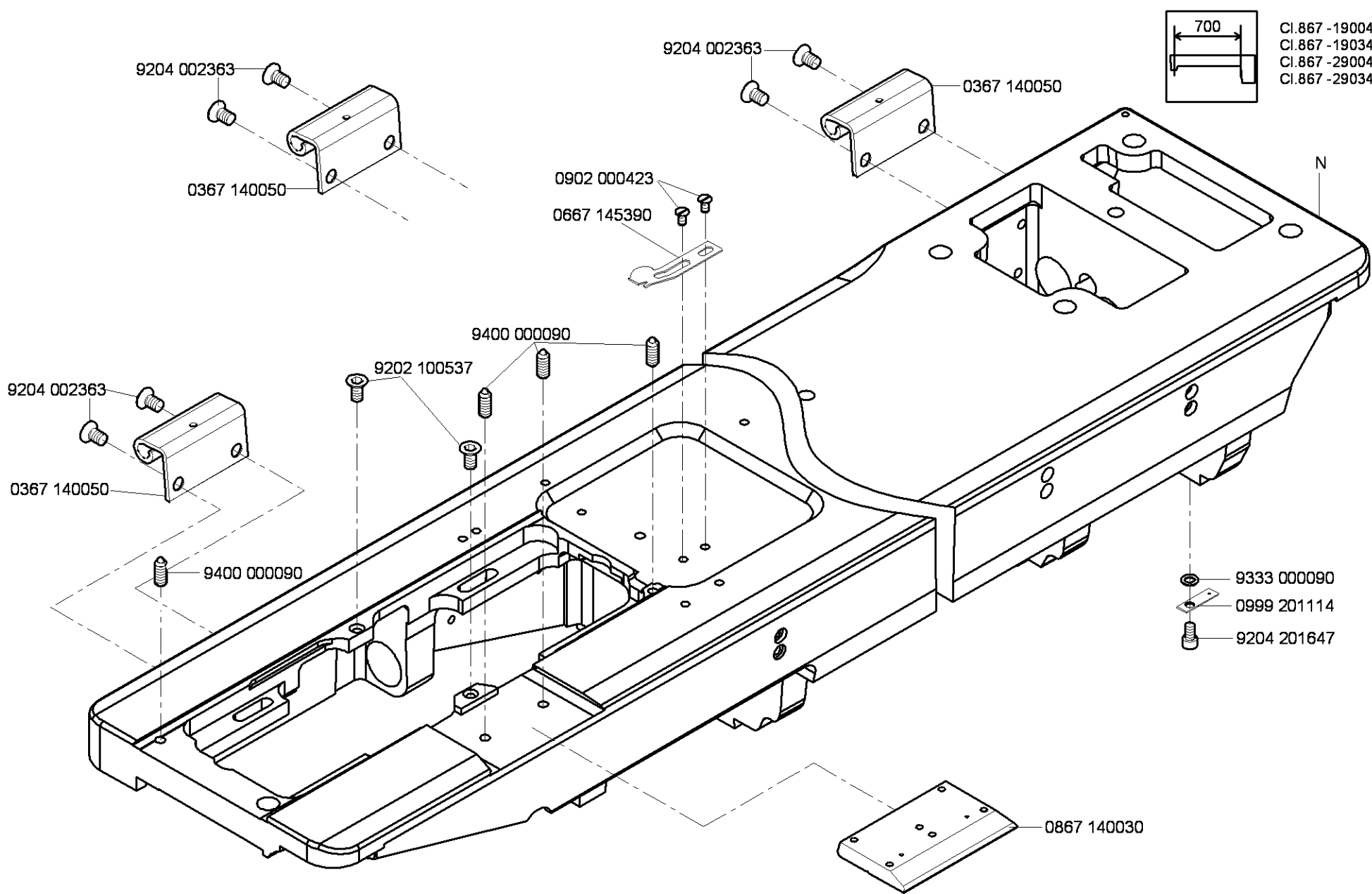
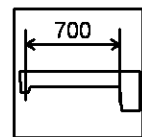

9204 002363

9204 002363

0367 140050

0367 140050

0902 000423

0667 145390

N

9400 000090

9202 100537

9204 002363

0367 140050

9400 000090

9333 000090

0999 201114

9204 201647

0867 140030

N - nicht als Einzelteil lieferbar
not available as separate part

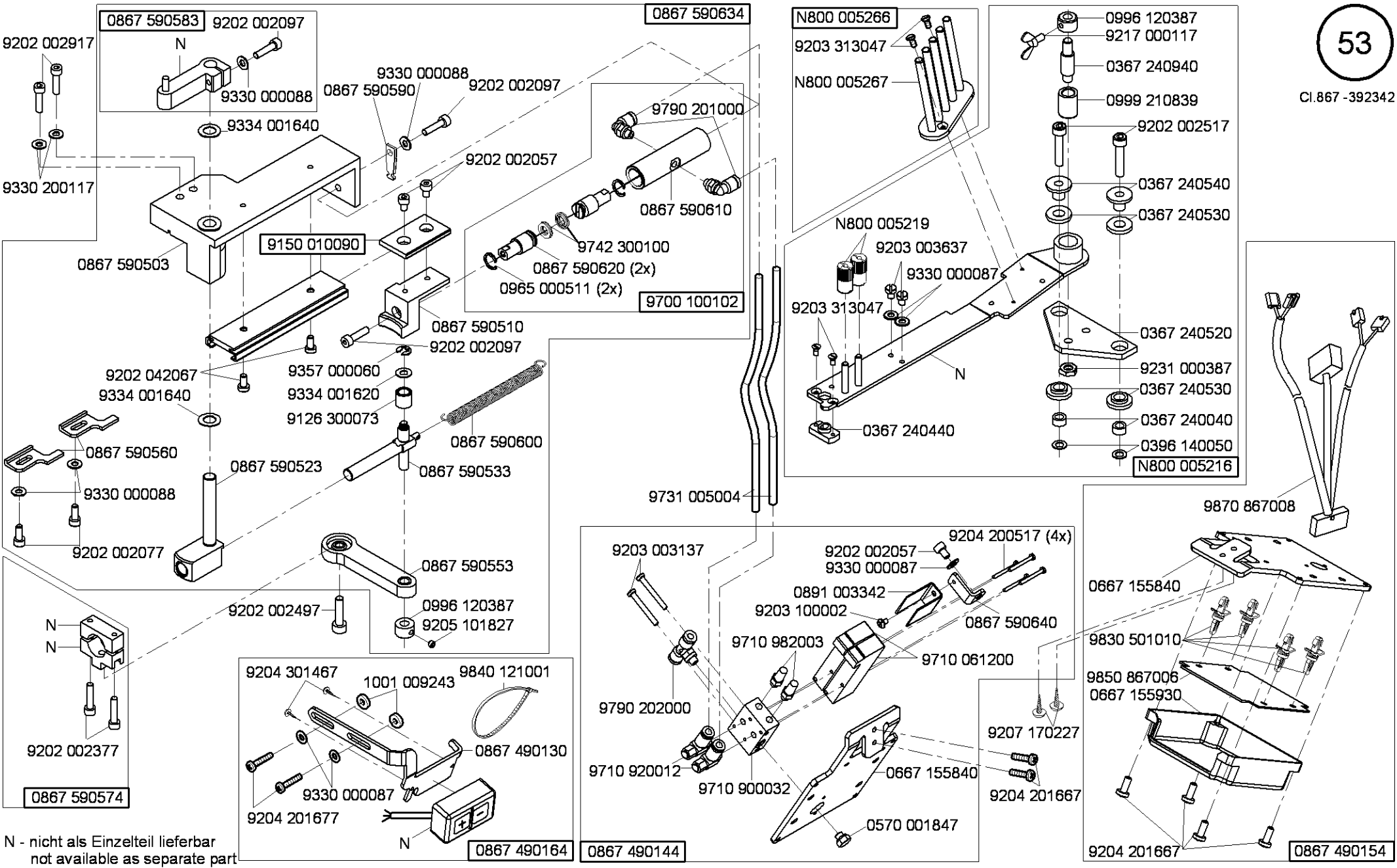

N - nicht als Einzelteil lieferbar
not available as separate part

* siehe Näheinrichtungen
see sewing equipment

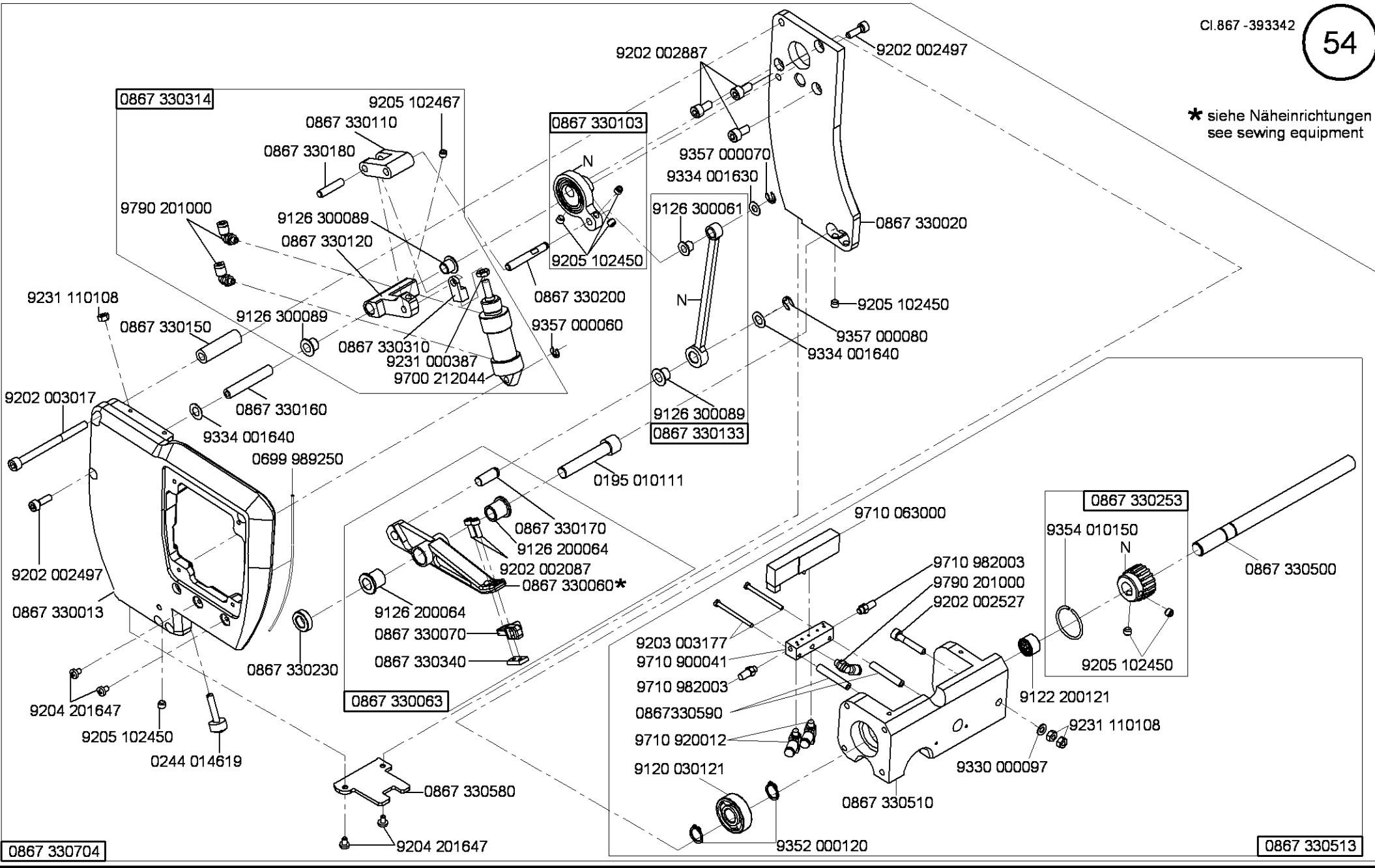

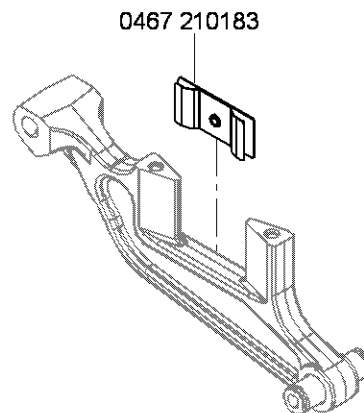
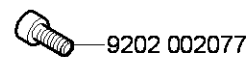
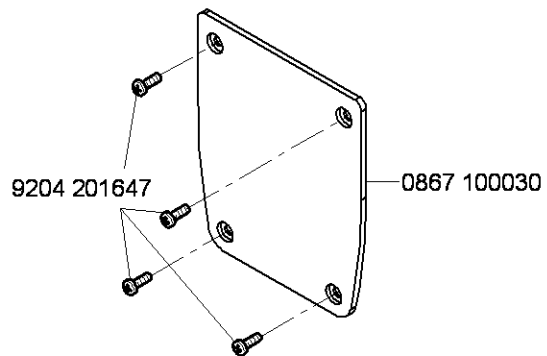
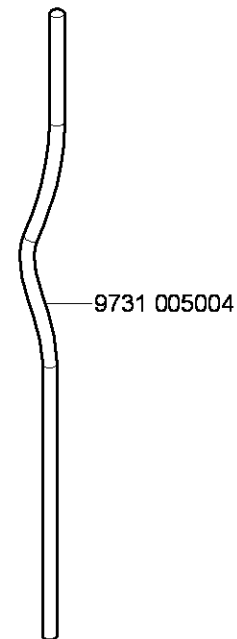
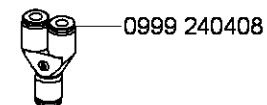
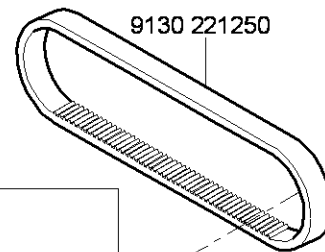
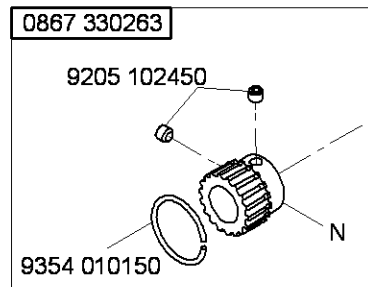
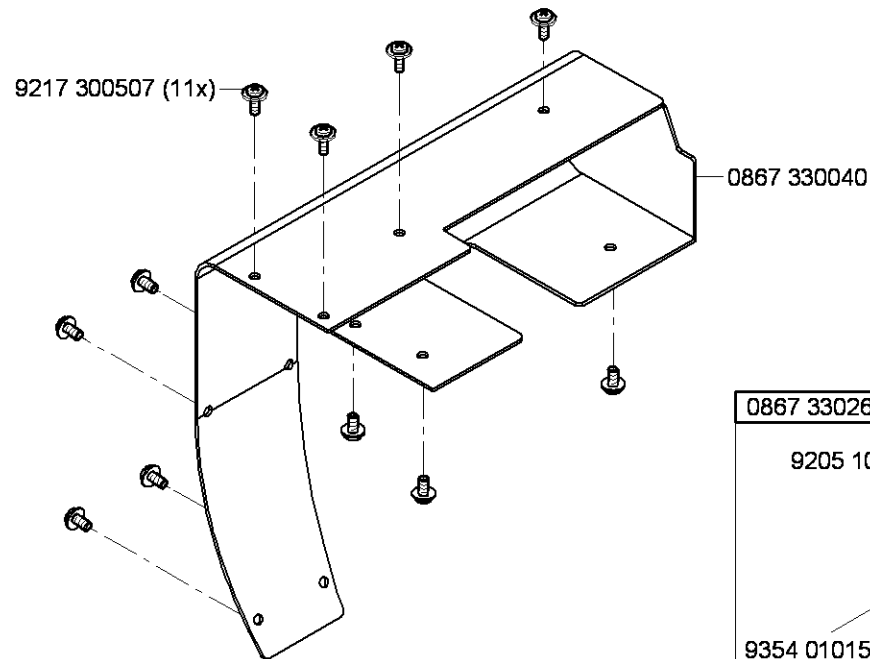

9822 510001*
9822 510003**

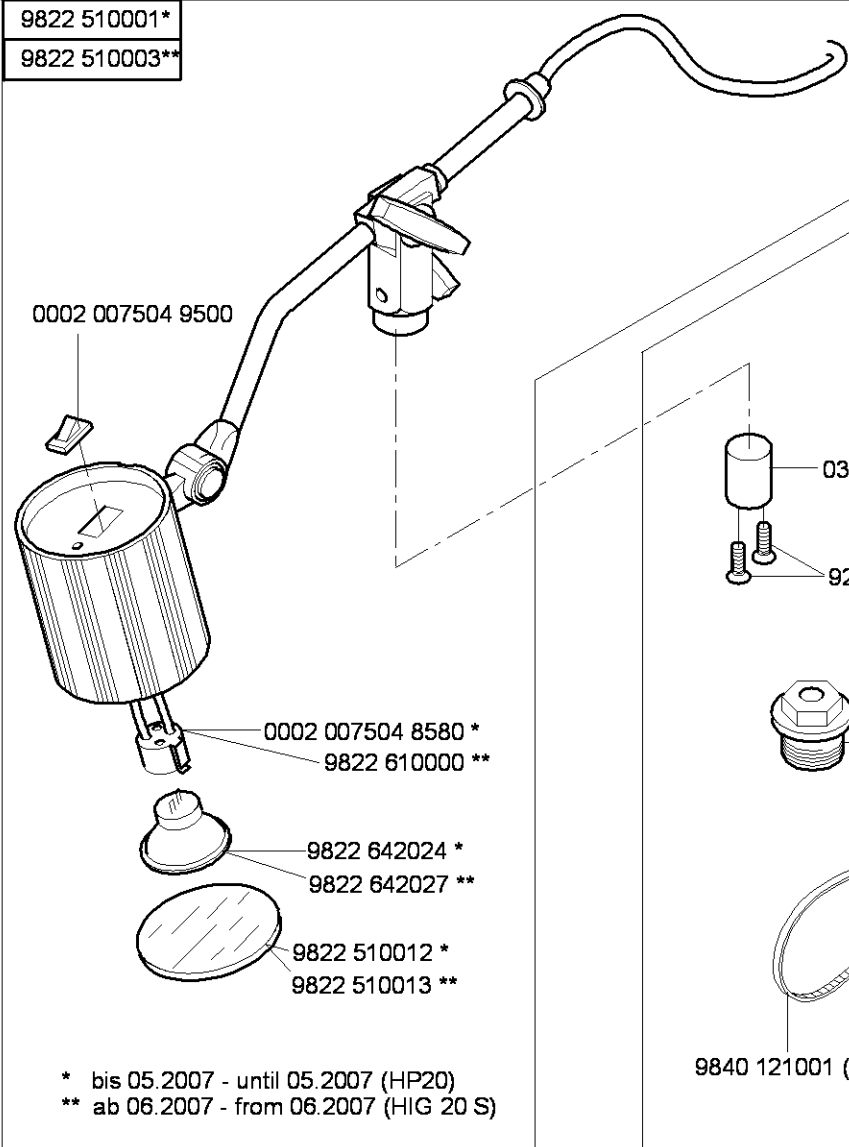

* bis 05.2007 - until 05.2007 (HP20)
** ab 06.2007 - from 06.2007 (HIG 20 S)

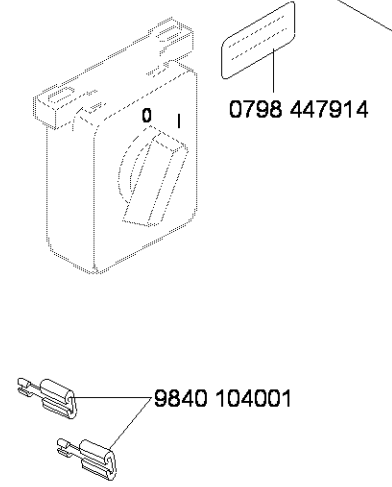
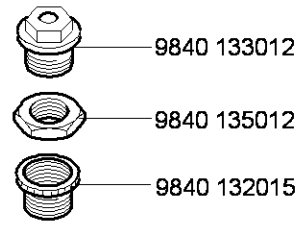
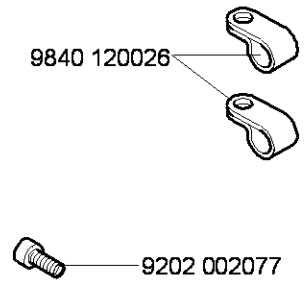
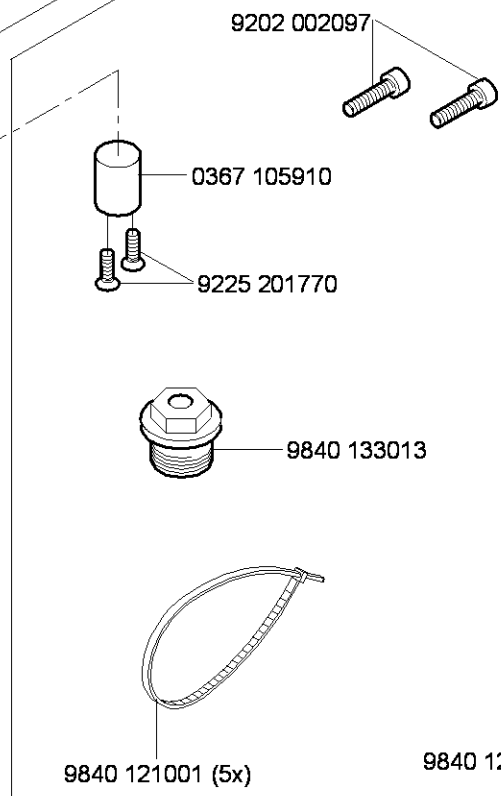

9880 867100

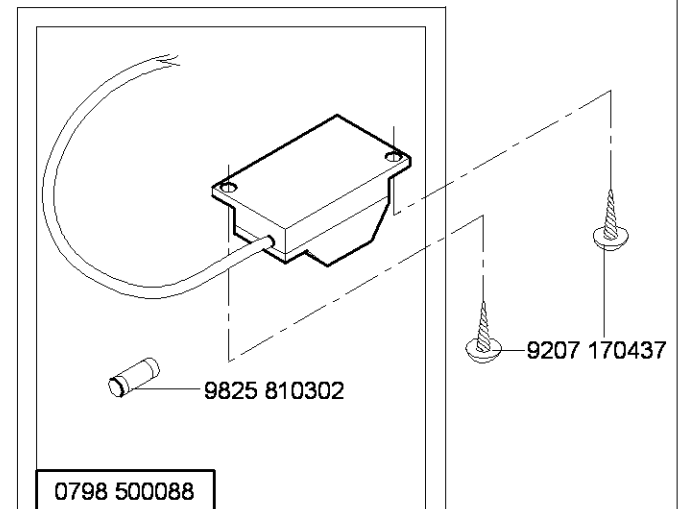
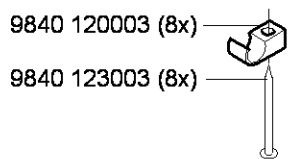

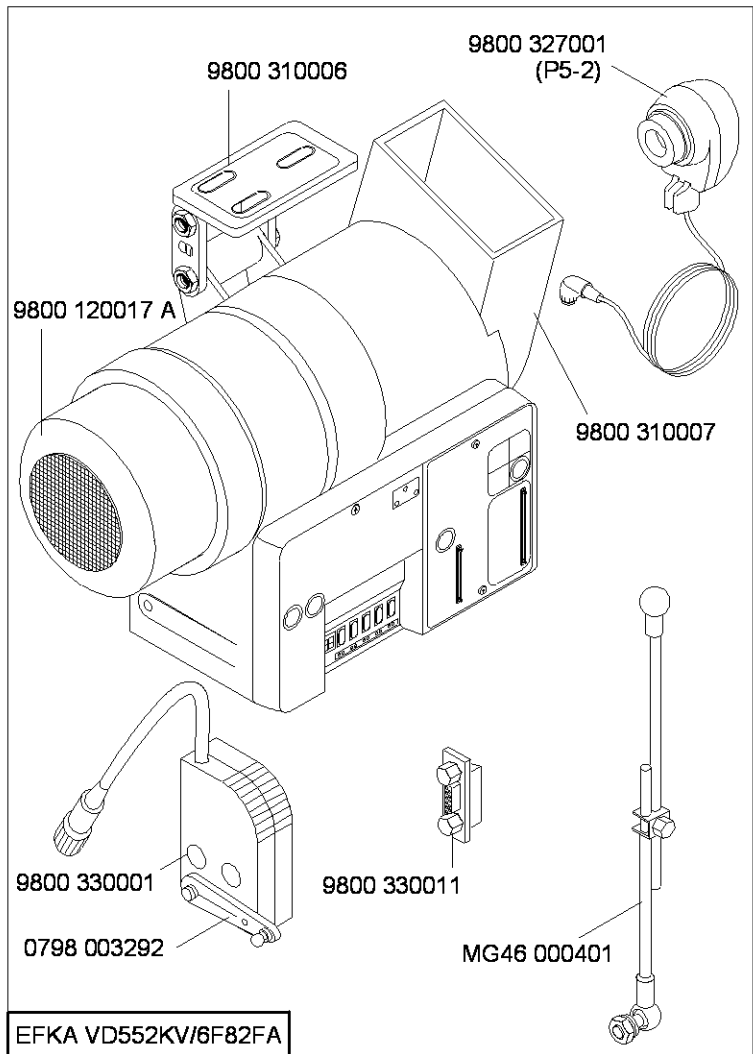

EFKA VD552KV/6F82FA

9800 110002 A	FIR 1147-F.752.3 3x230-400V/ 50hz
9800 110002 D	FIR 1148-752.3 3x230-400V/ 60hz

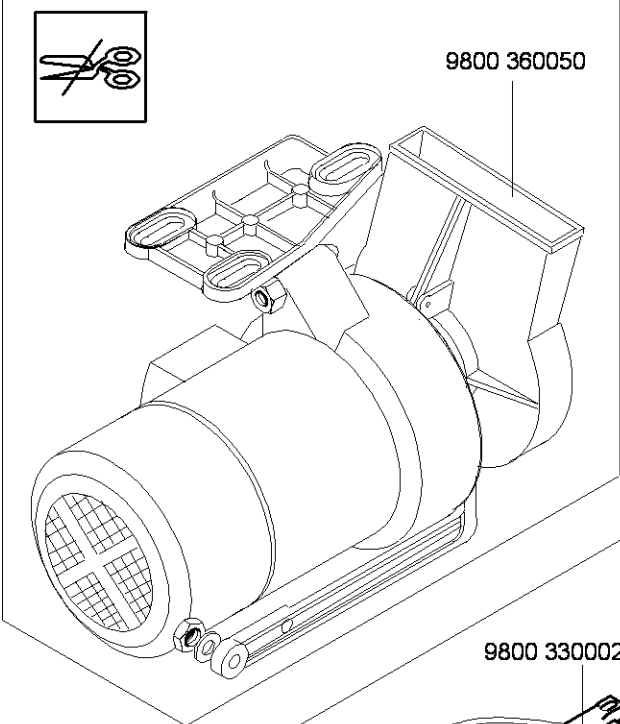

EFKA DC1600/DA82GA

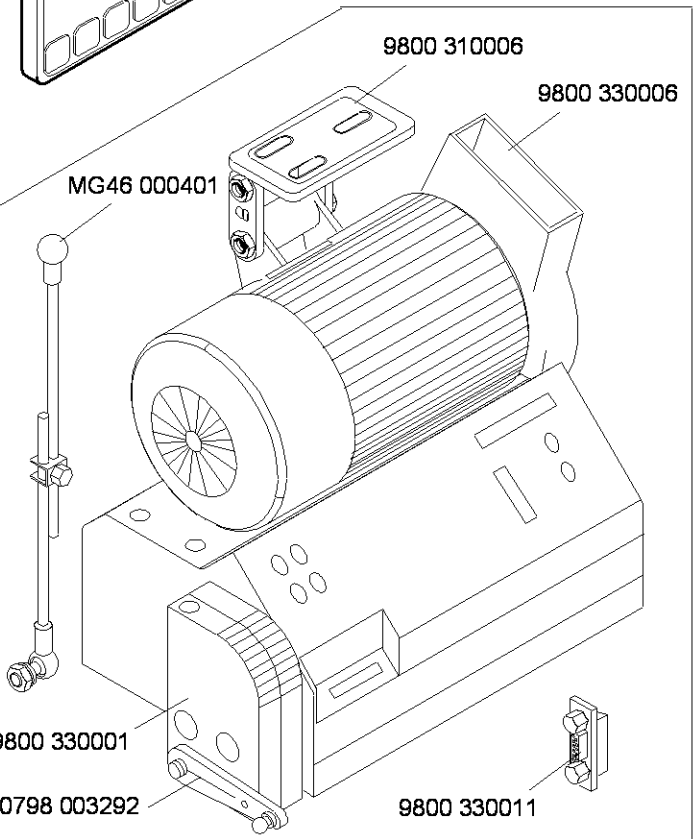
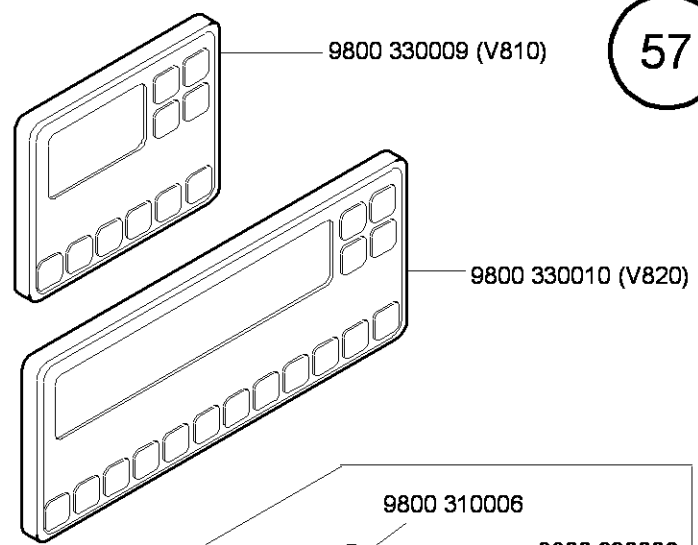

Netz	n1/min	1	2
3x230V/50HZ	3000	9130 500110	9130 104225
3x400V/50HZ	3000	9130 500070	9130 104220
3x230V/60HZ	3000	9130 500070	9130 104220

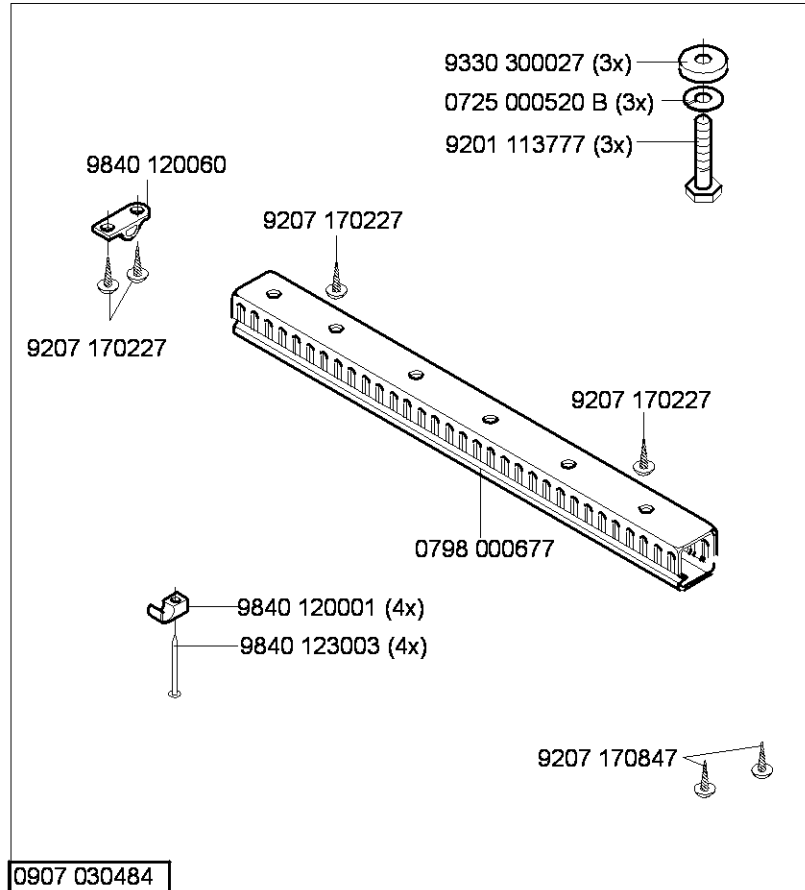

0907 030484

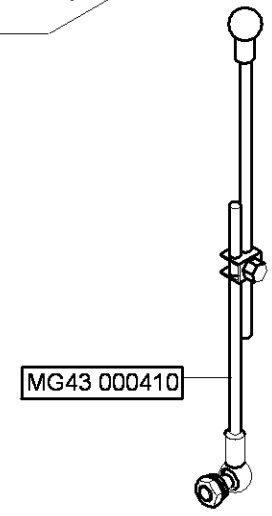
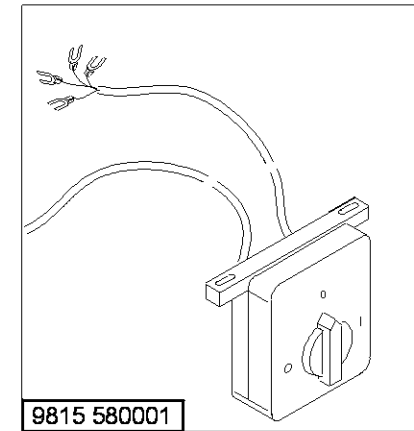
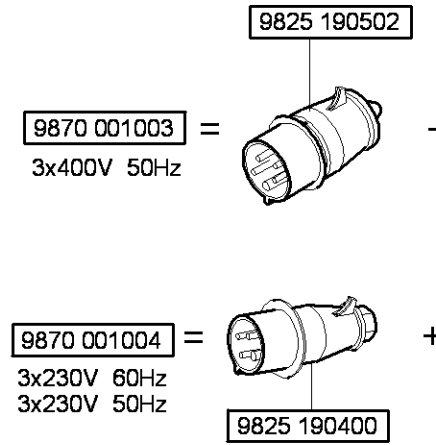
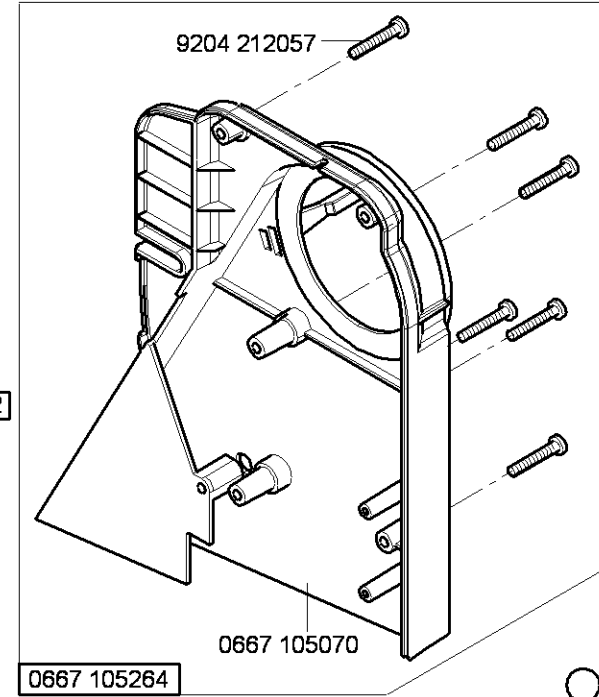
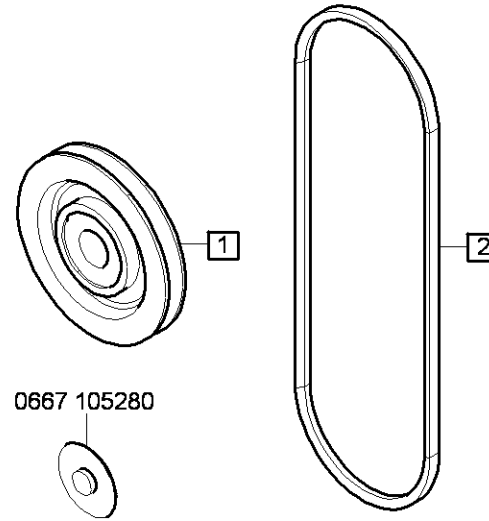

Netz	n1/min	1	2
3x230V/50HZ	3000	9130 500110	9130 104230
3x400V/50HZ	3400	9130 500130	9130 104240
3x230V/60HZ	3000	9130 500070	9130 104225
	3400	9130 500090	9130 104230

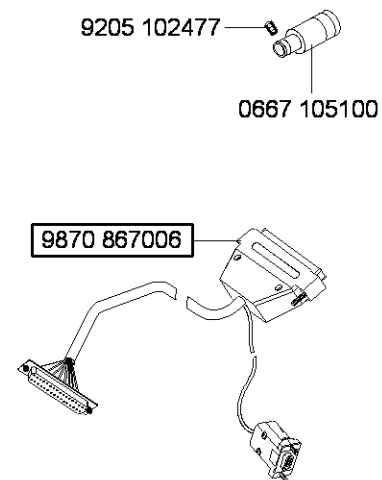
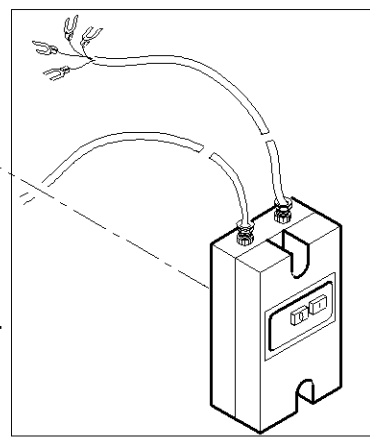
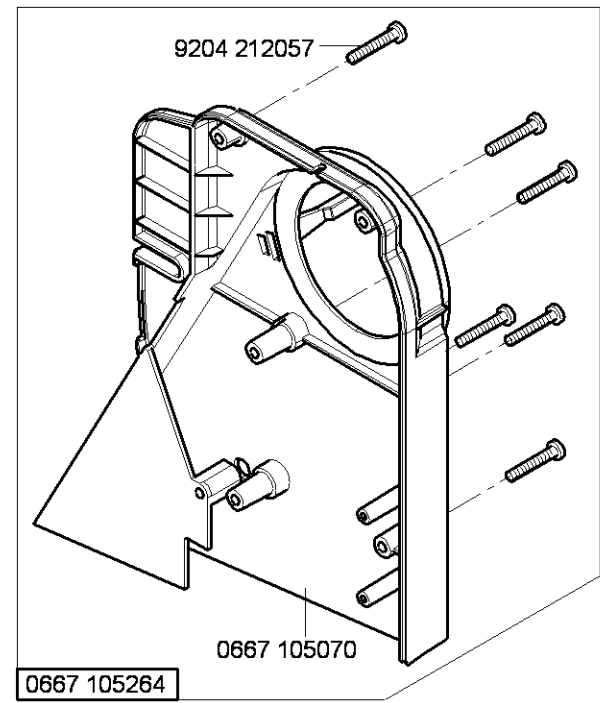
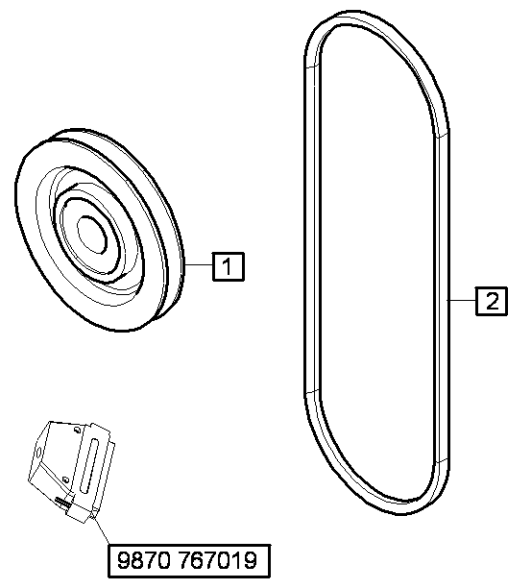
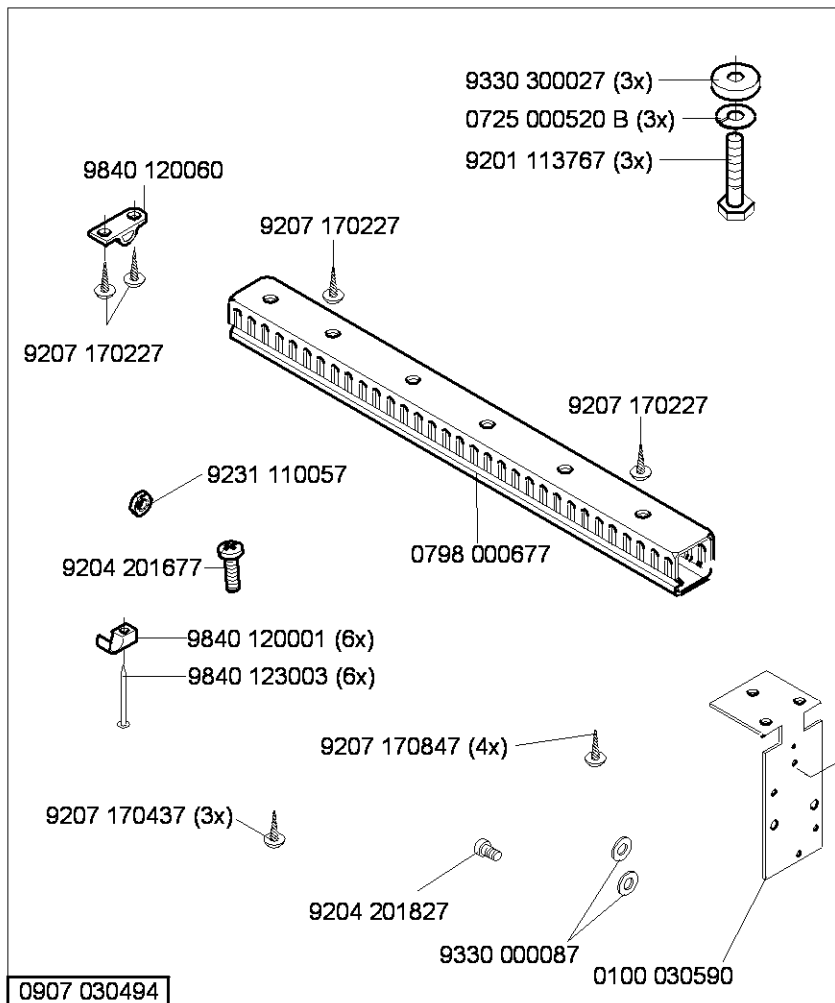

Netz	n1/min	1	2
1x230V/50/60HZ	3000	9130 500050	9130 104213
1x230V/50/60HZ	3400	9130 500070	

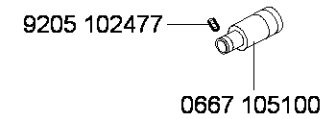
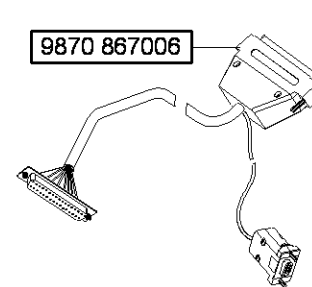
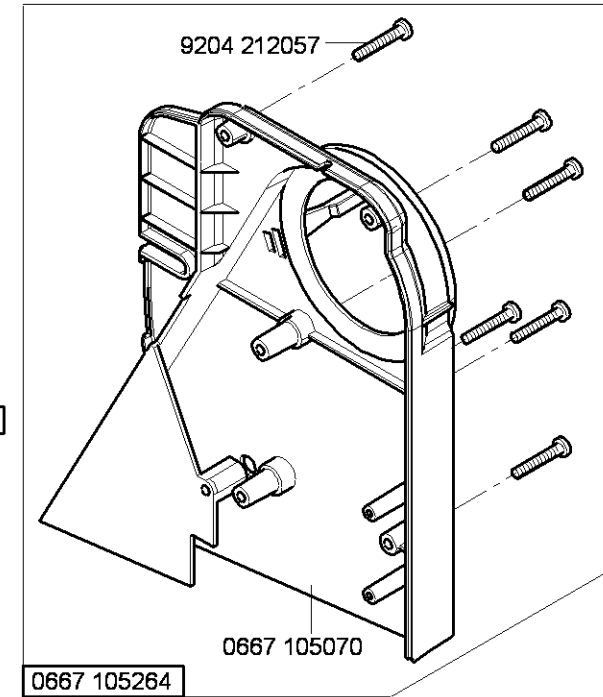
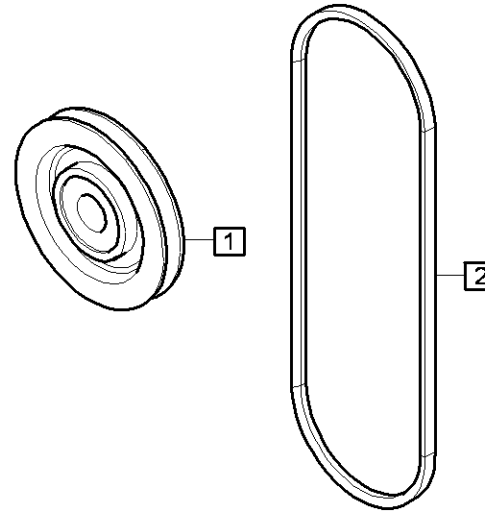
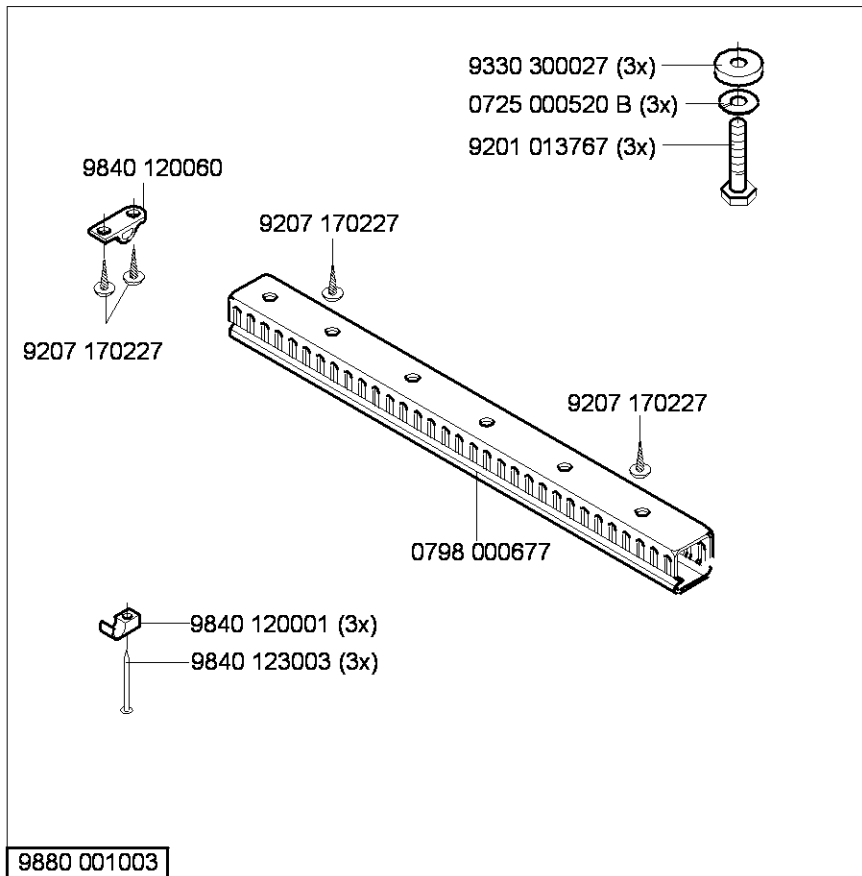

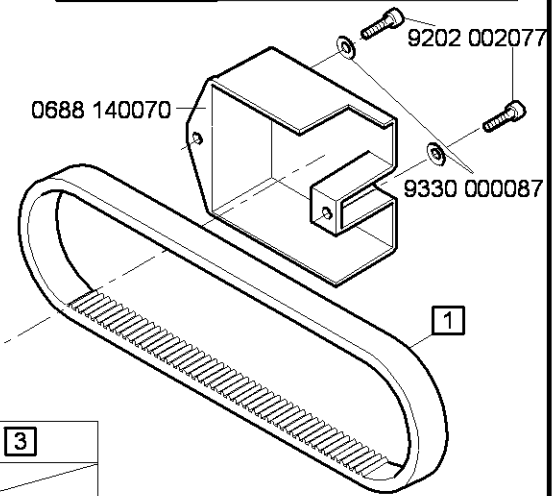
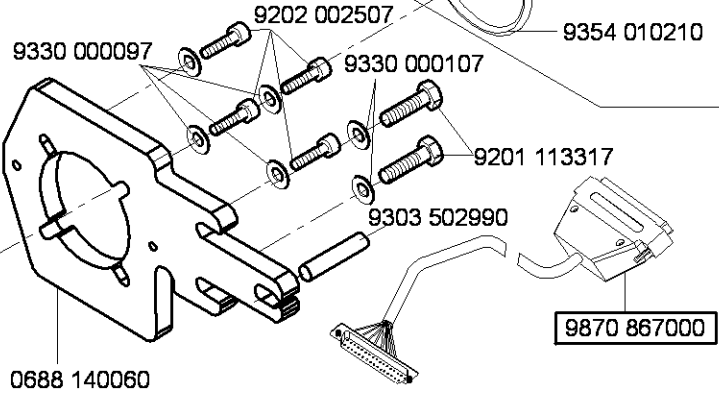
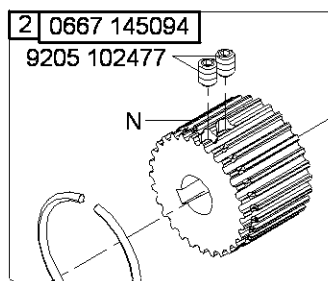
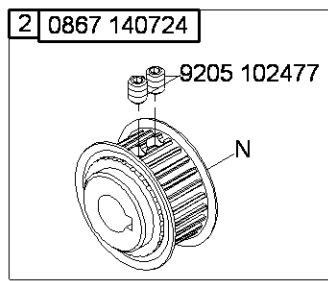
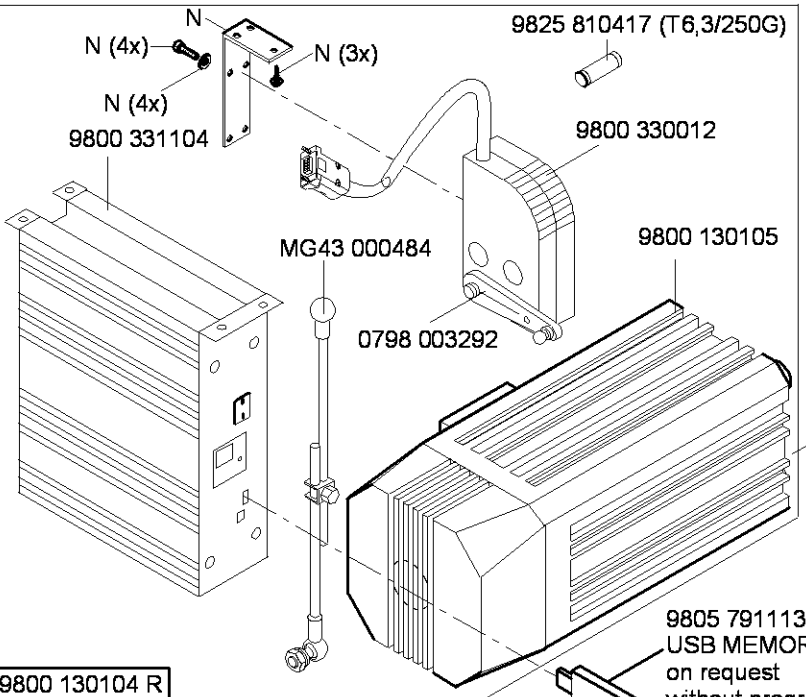
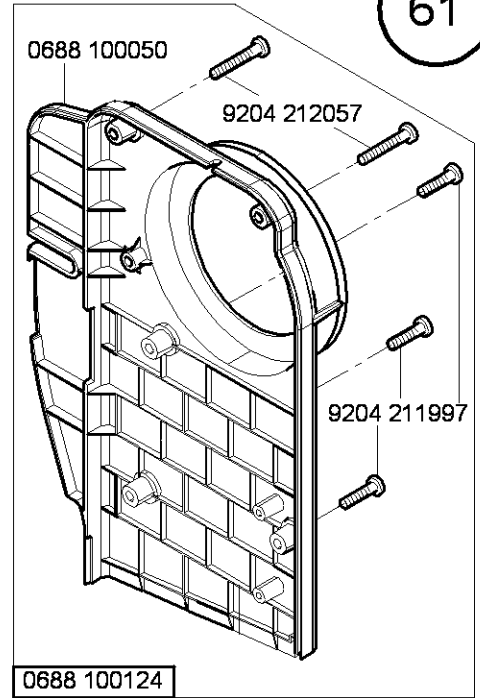
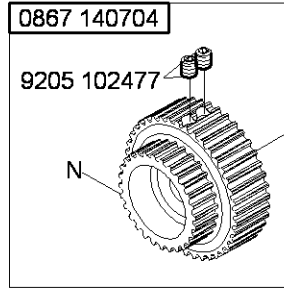
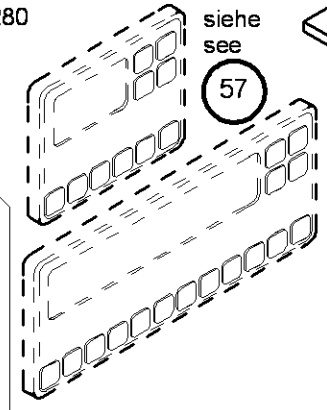
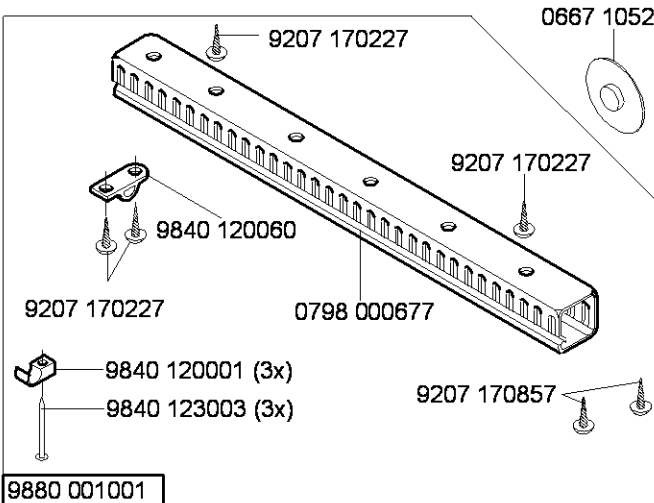

9805 791113
USB MEMORY STICK
on request
without program
auf Wunsch
ohne programm

i	1	2	siehe/see ②	3
1:1	9130 221140	0667 145094	0667 145044	
1,6:1	9130 221290	0867 140724	0867 140704	9800 327005

N - nicht als Einzelteil lieferbar
not available as separate part

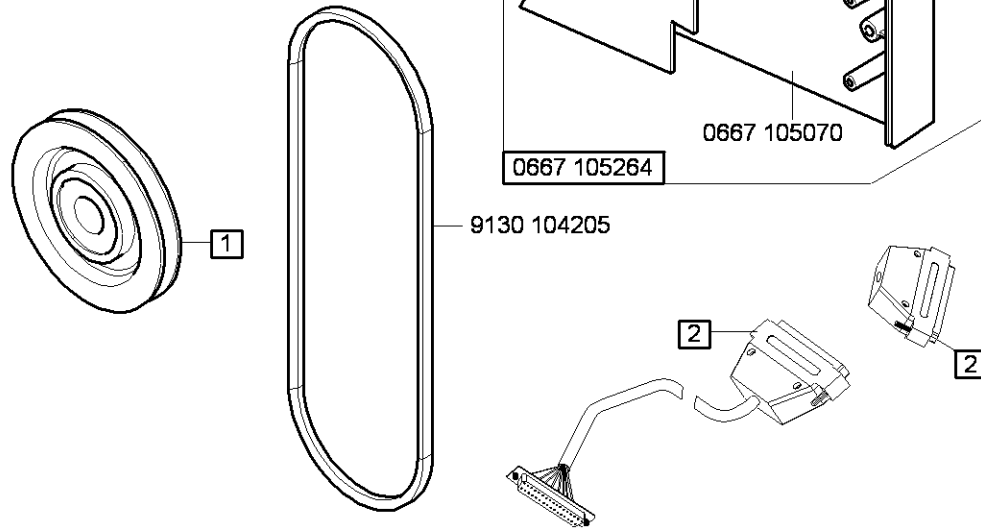
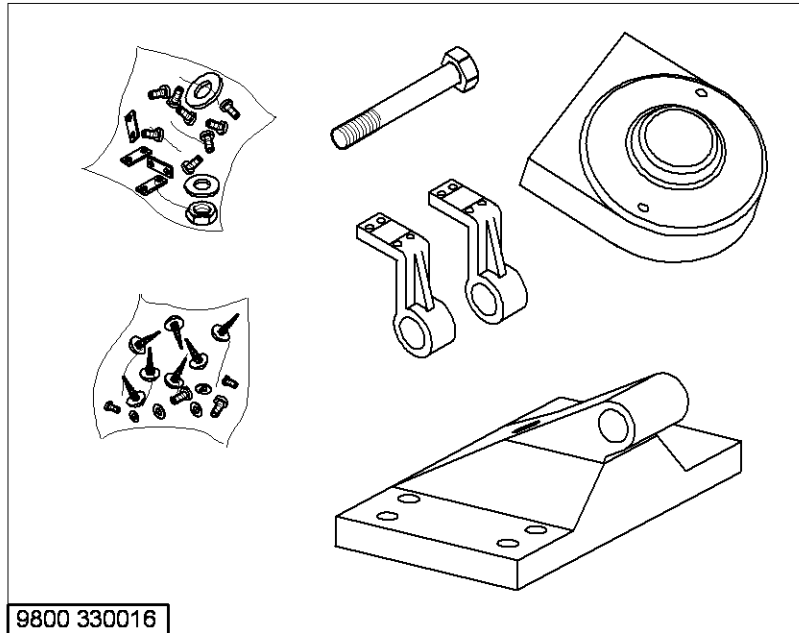
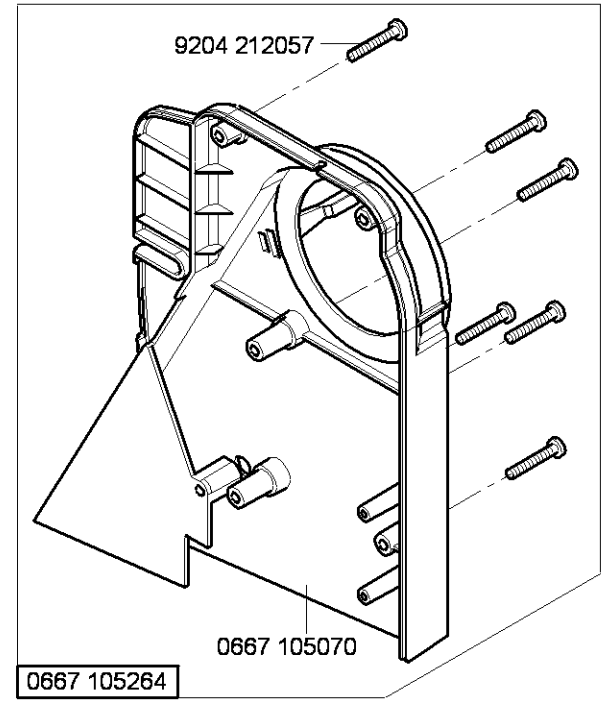
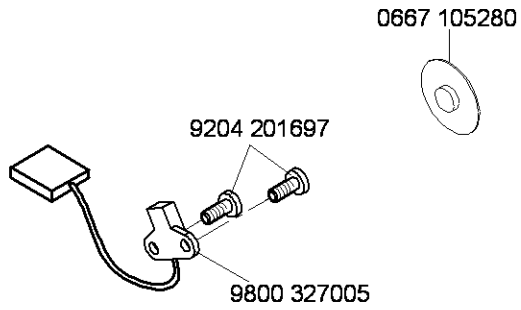
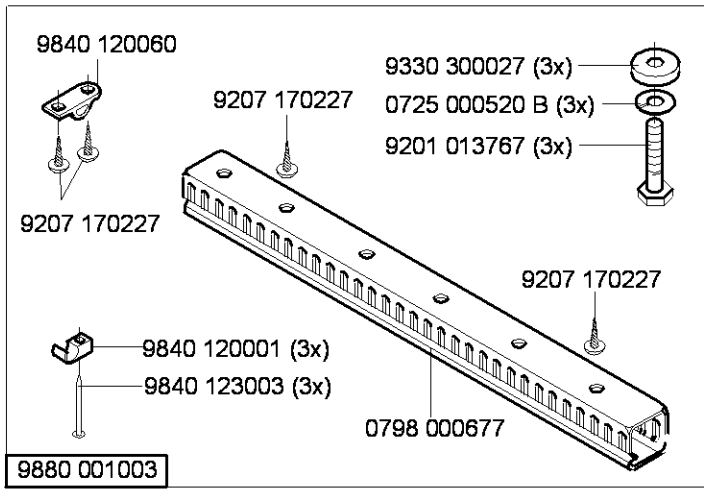

	n1/min	1	2
9880 867010	3000	9130 500750	9870 867000
9880 867011	3400	9130 500770	9870 867000
9880 867012	3000	9130 500750	9870 767019

N - nicht als Einzelteil lieferbar
 not available as separate part

für EFKA DC1550DA321G

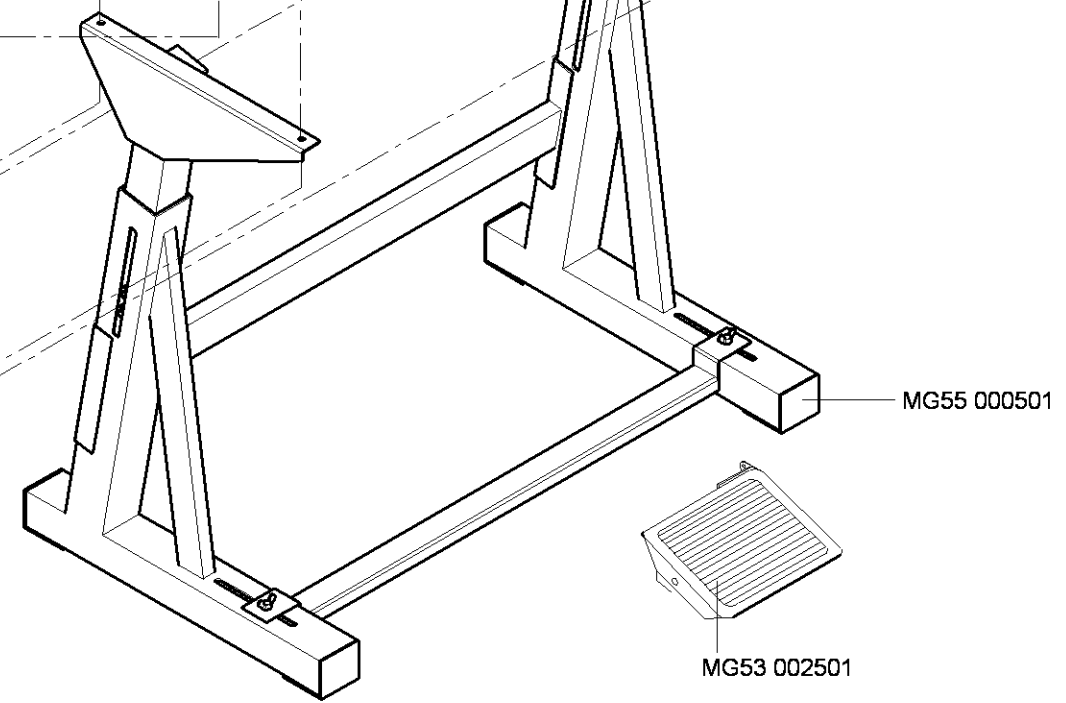
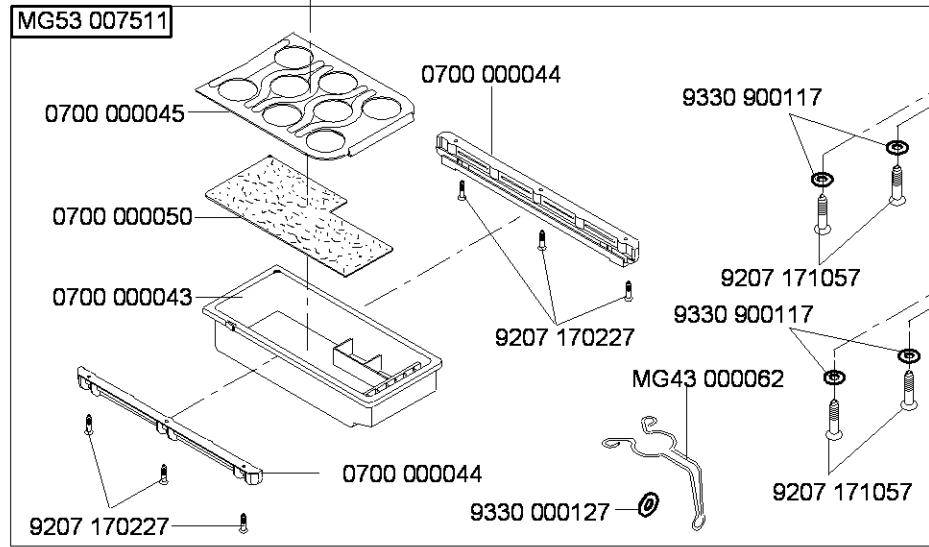
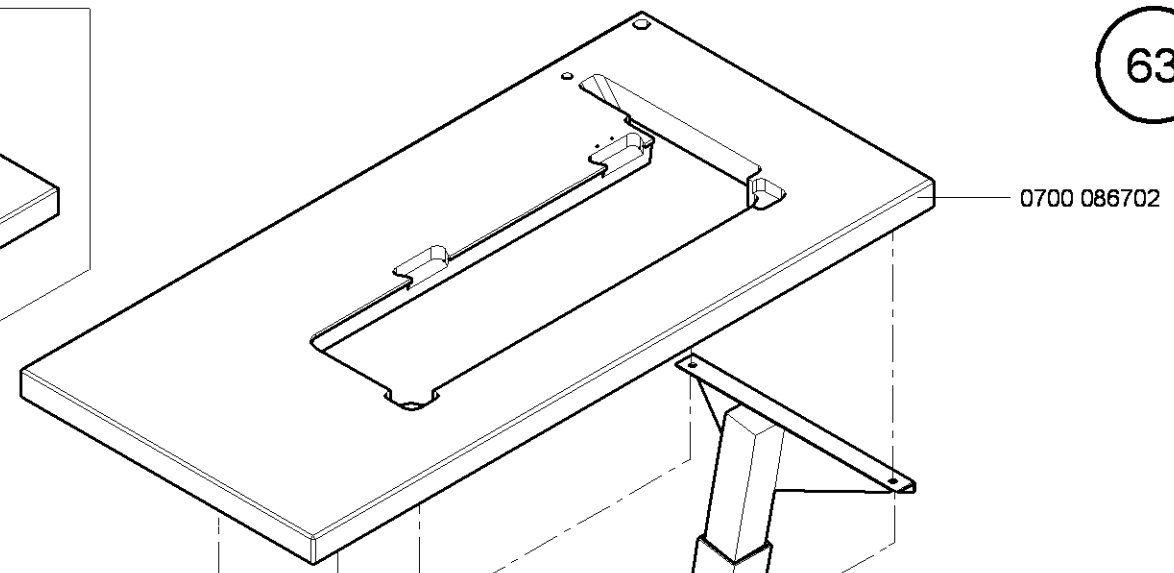
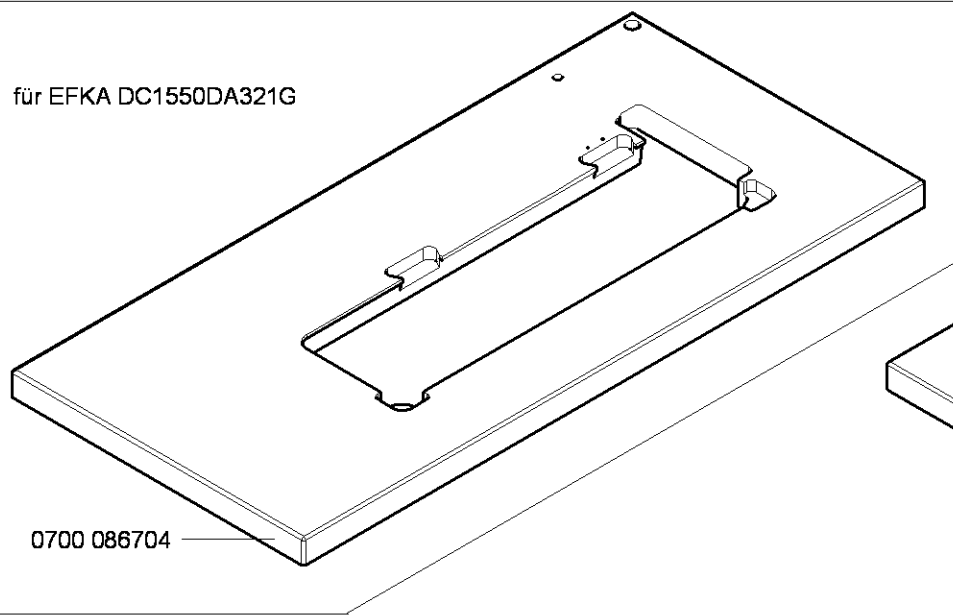

für EFKA DC1550DA321G

bis 01/2010 0700 086754
ab 02/2010 0700 086766

0700 086766

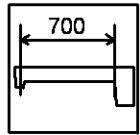

0700 086764

bis 01/2010 0700 086752
ab 02/2010 0700 086764

0906 020164

0700 000045

0700 000044

9330 900117

0700 000050

0700 000043

9207 170227

MG43 000062

0700 000044

9207 170227

9207 171067

9330 900117

9207 171067

MG58 000505

9231 110127

9330 000107

0917 030510

9357 200056

9305 001680

0994 270980

0907 030410

0907 030200

9231 110057 (6x)

0907 030410 (3x)

9203 003797 (6x)

0916 030364

auf Wunsch
on request

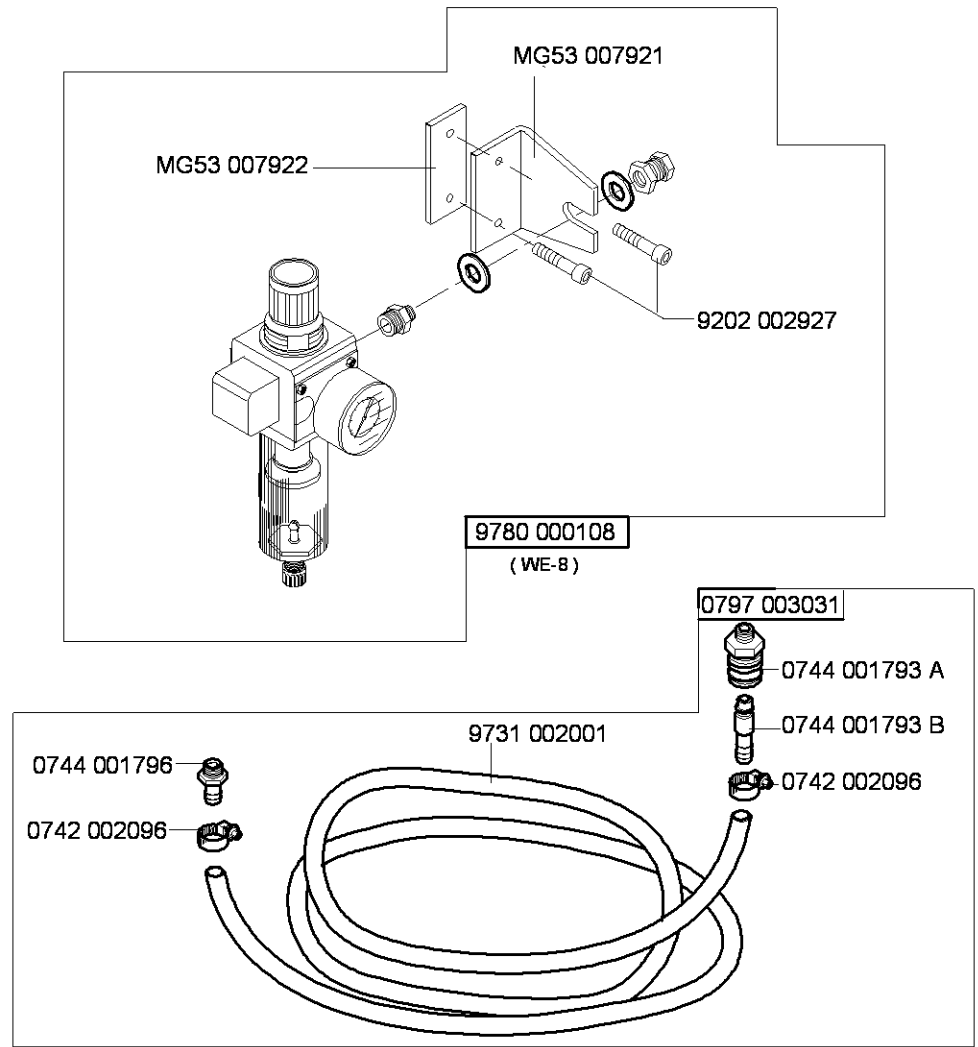

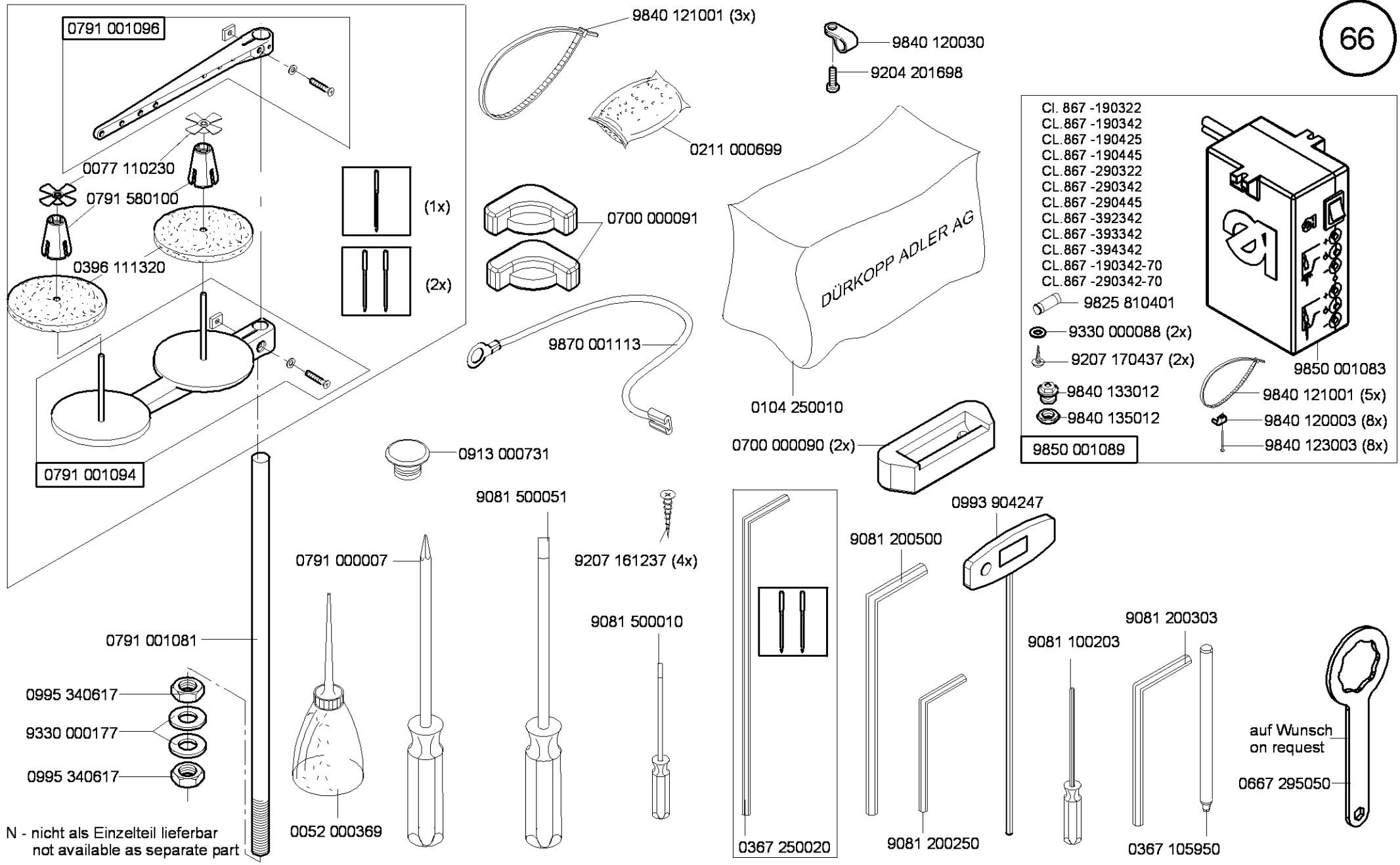

N - nicht als Einzelteil lieferbar
not available as separate part

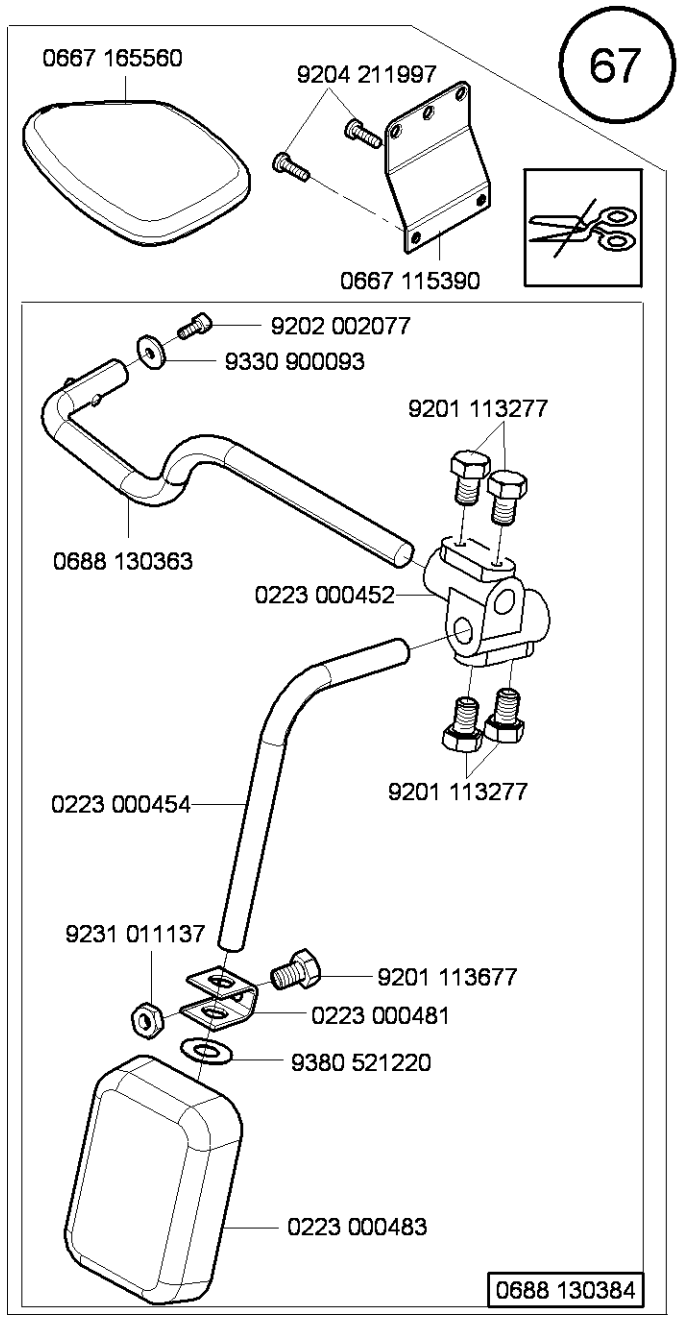
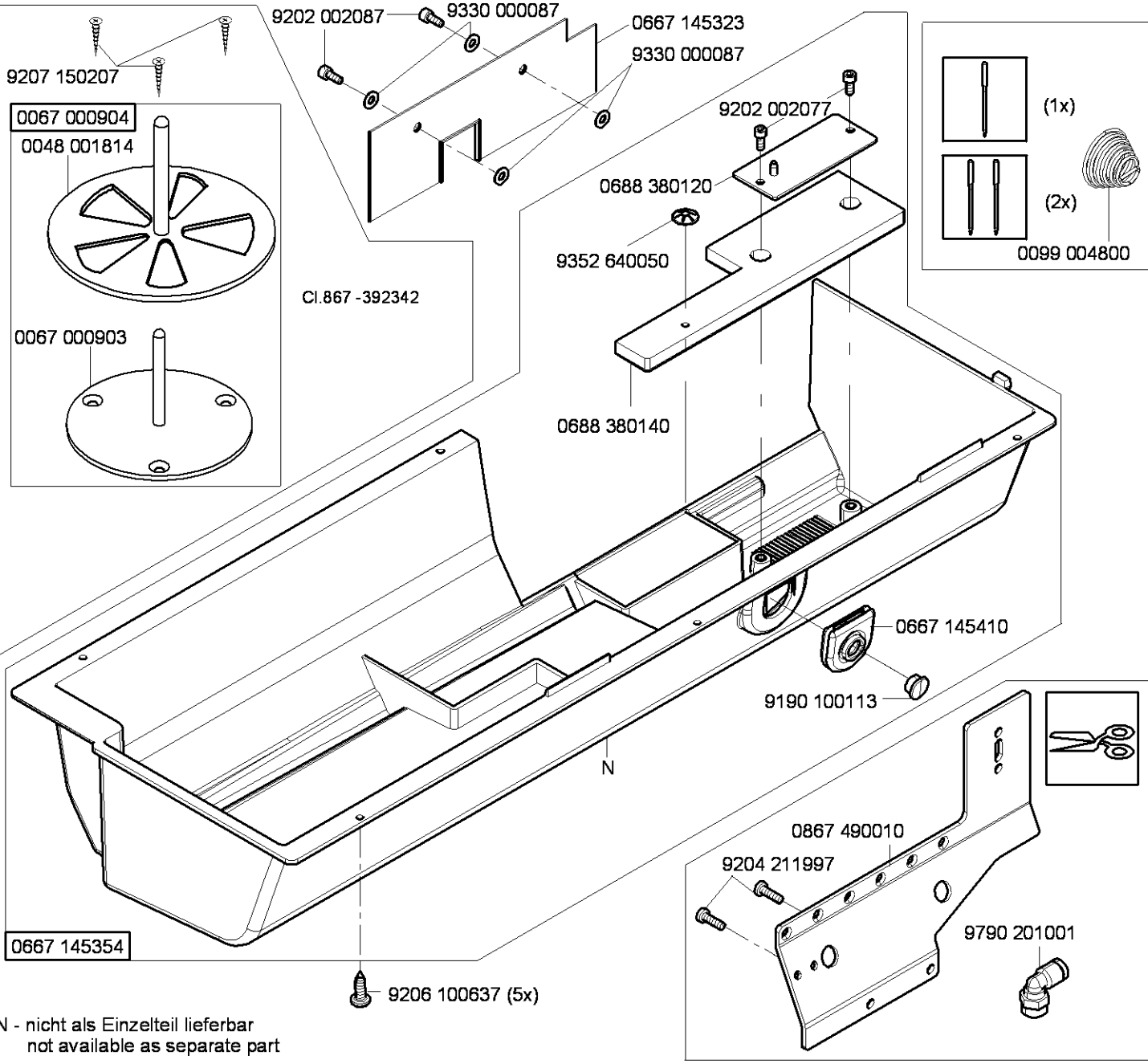

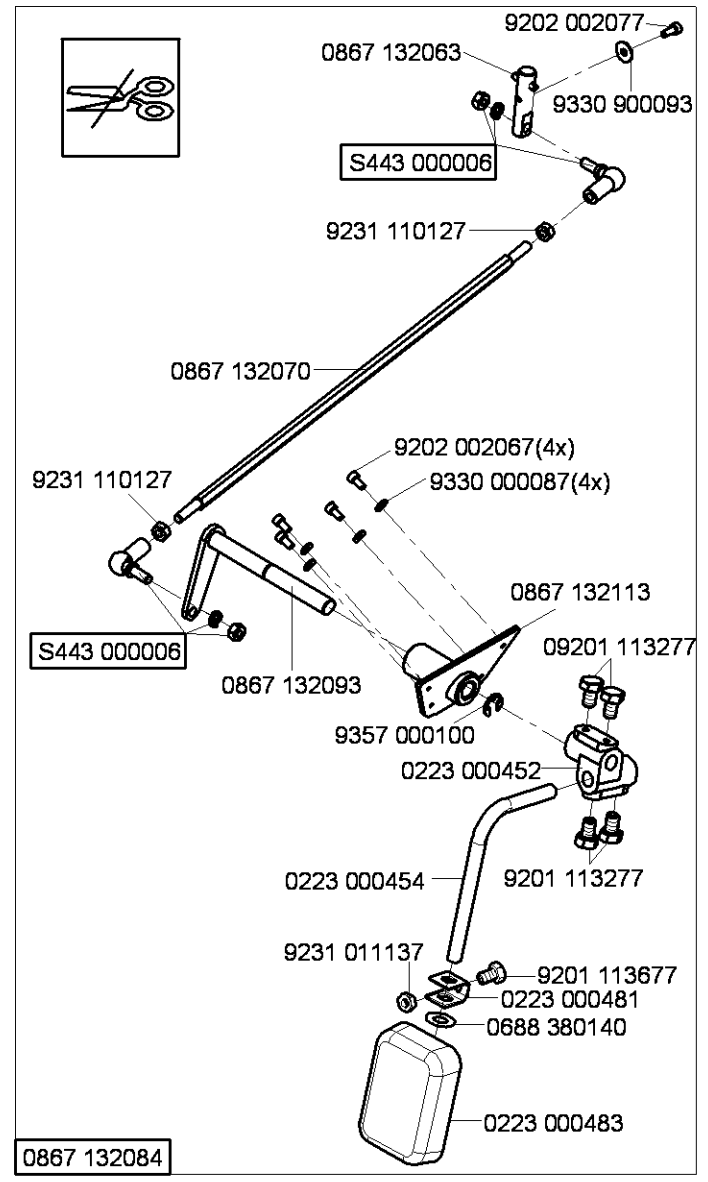
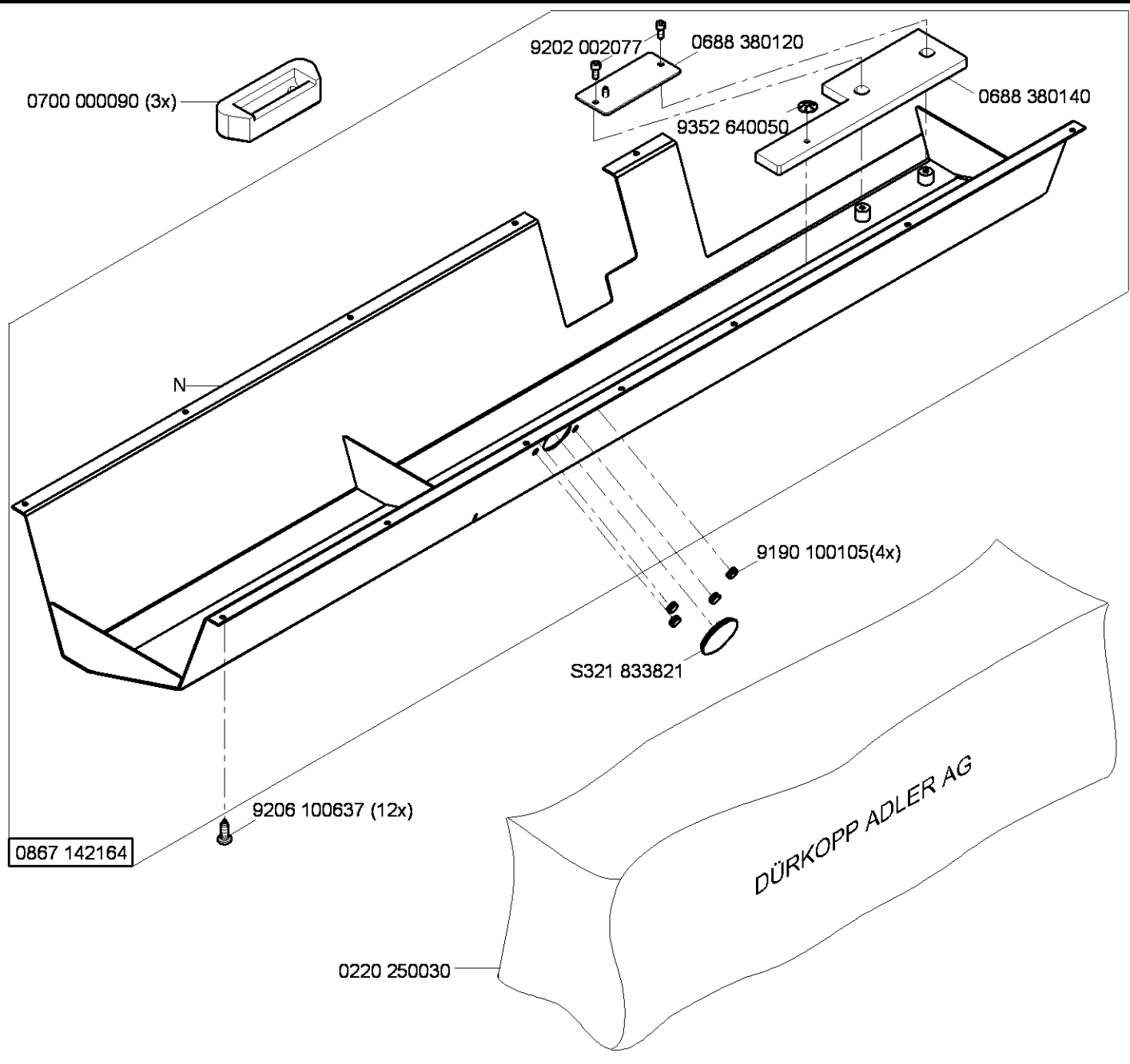

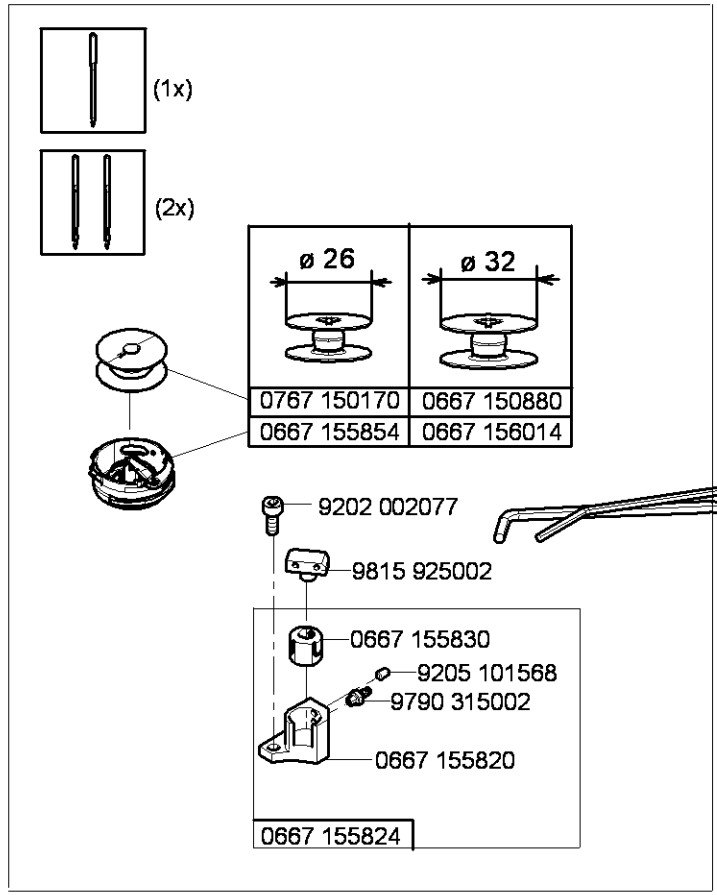
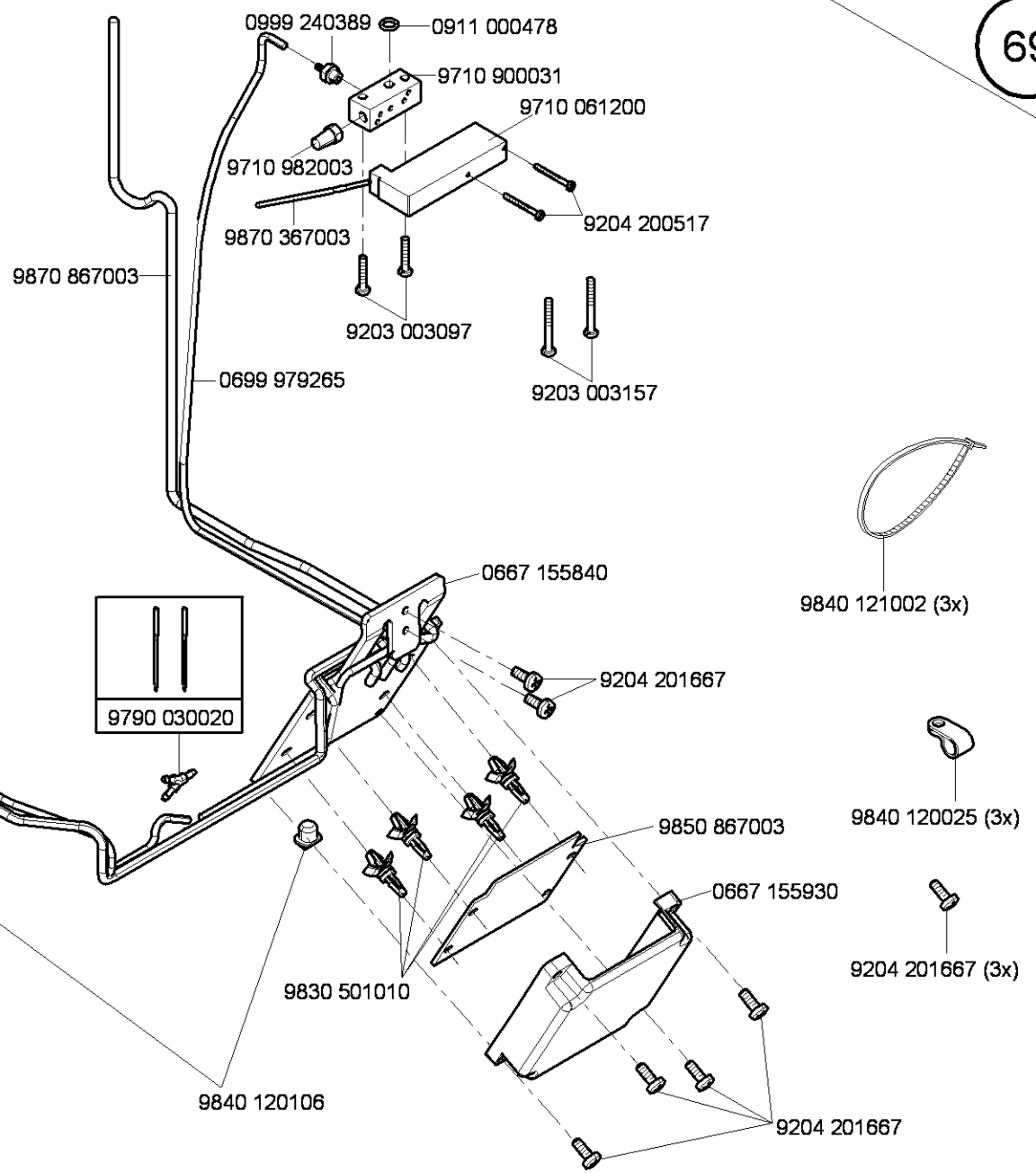
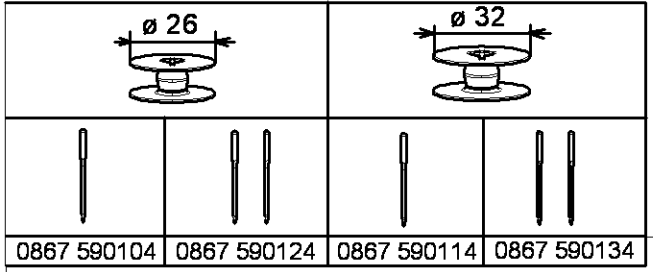

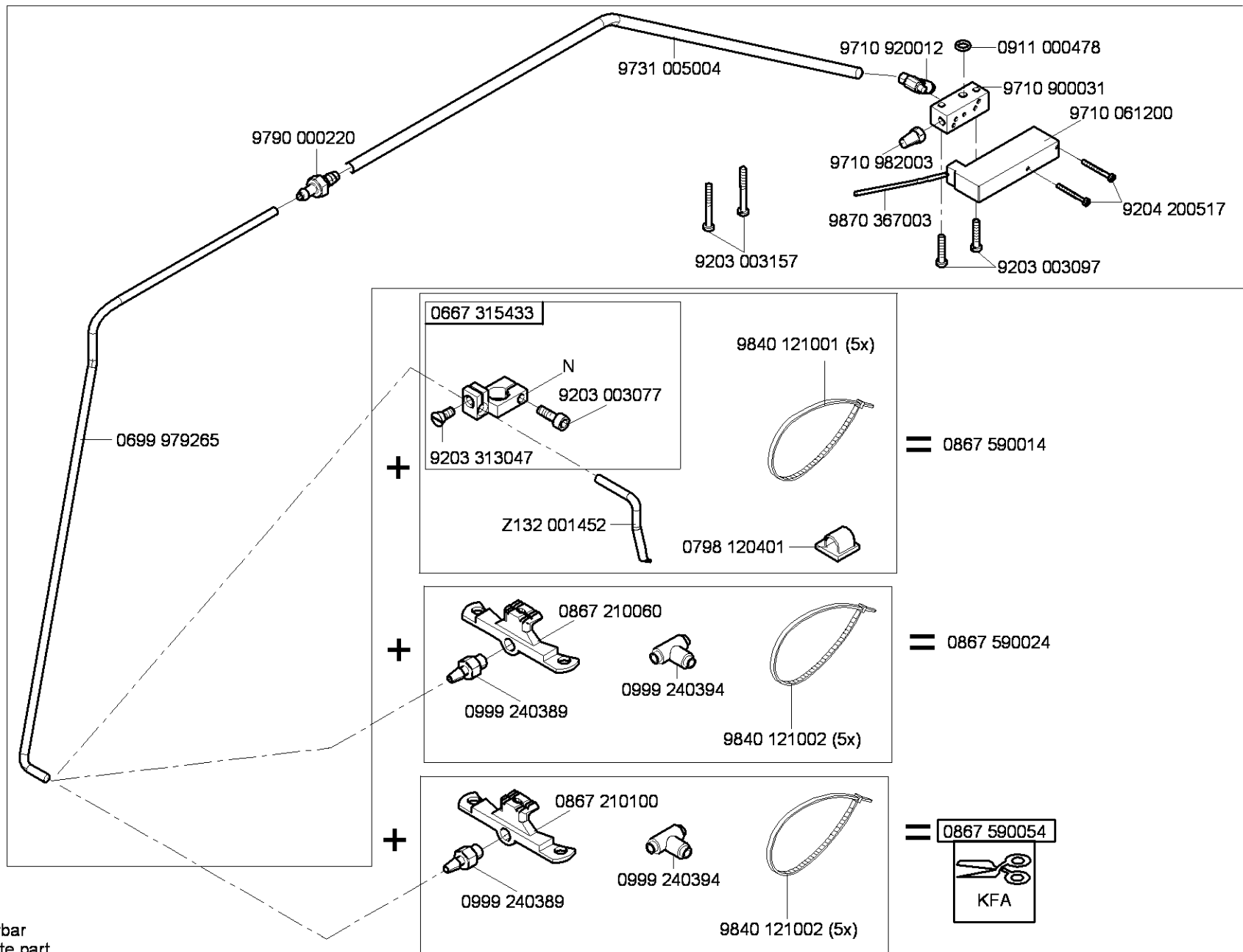

N - nicht als Einzelteil lieferbar
not available as separate part

N800 005655

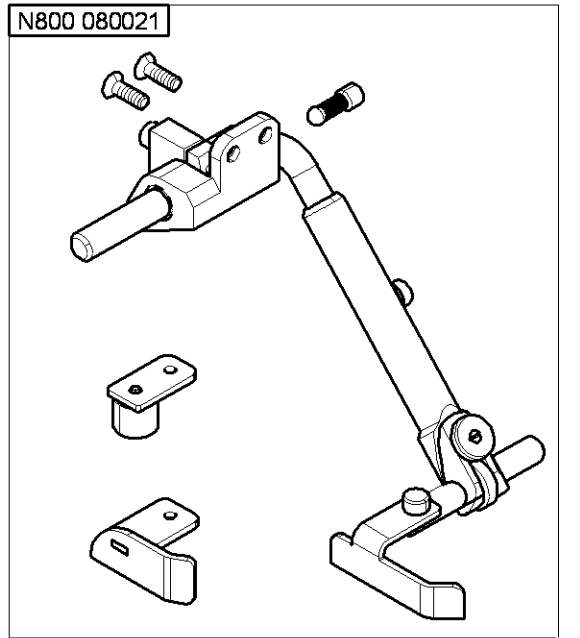
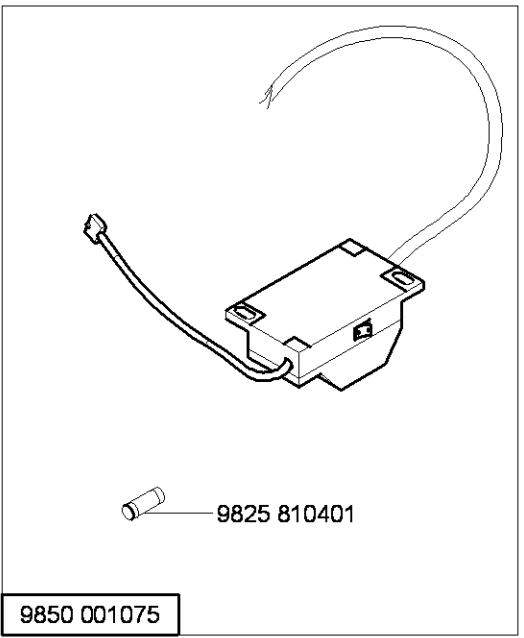
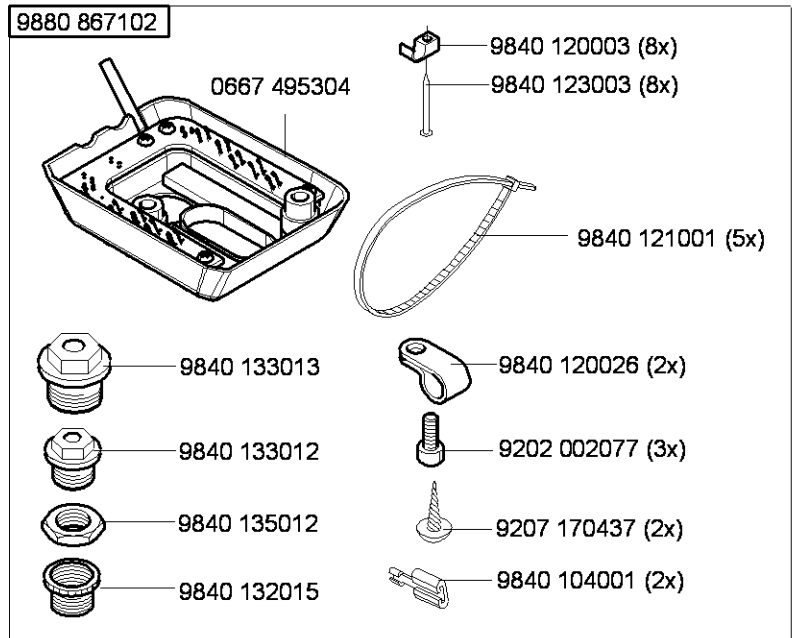
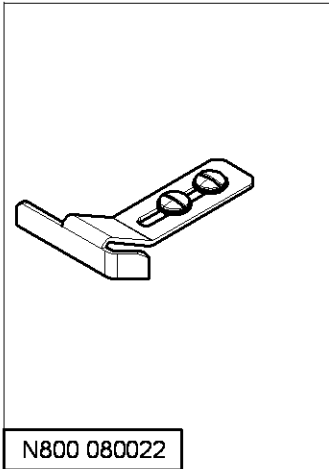
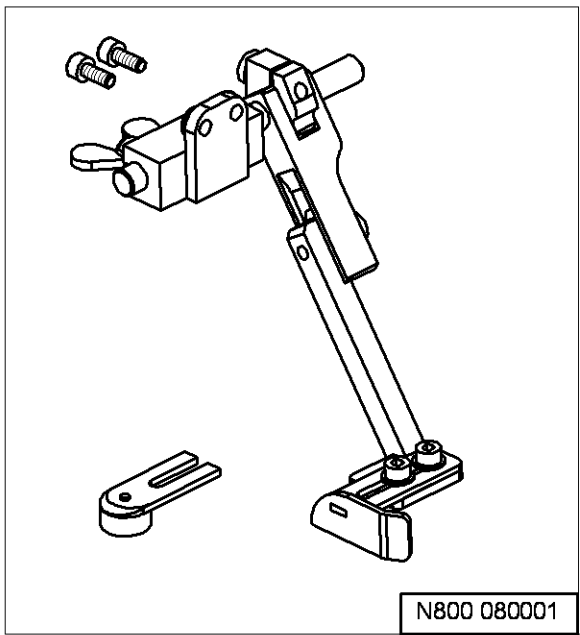
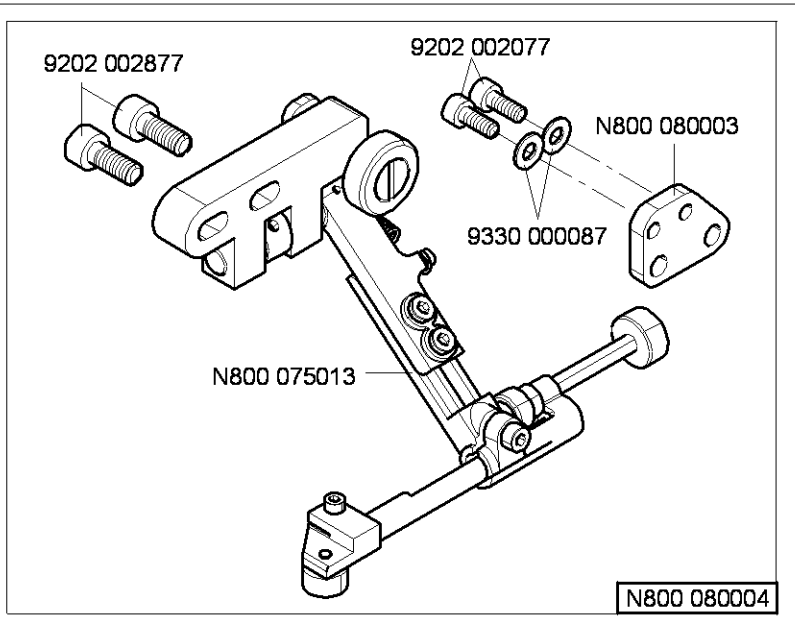
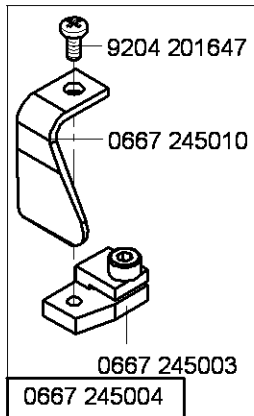

siehe Näherichtungen Blatt 1
see sewing equipment page 1
0867 590064

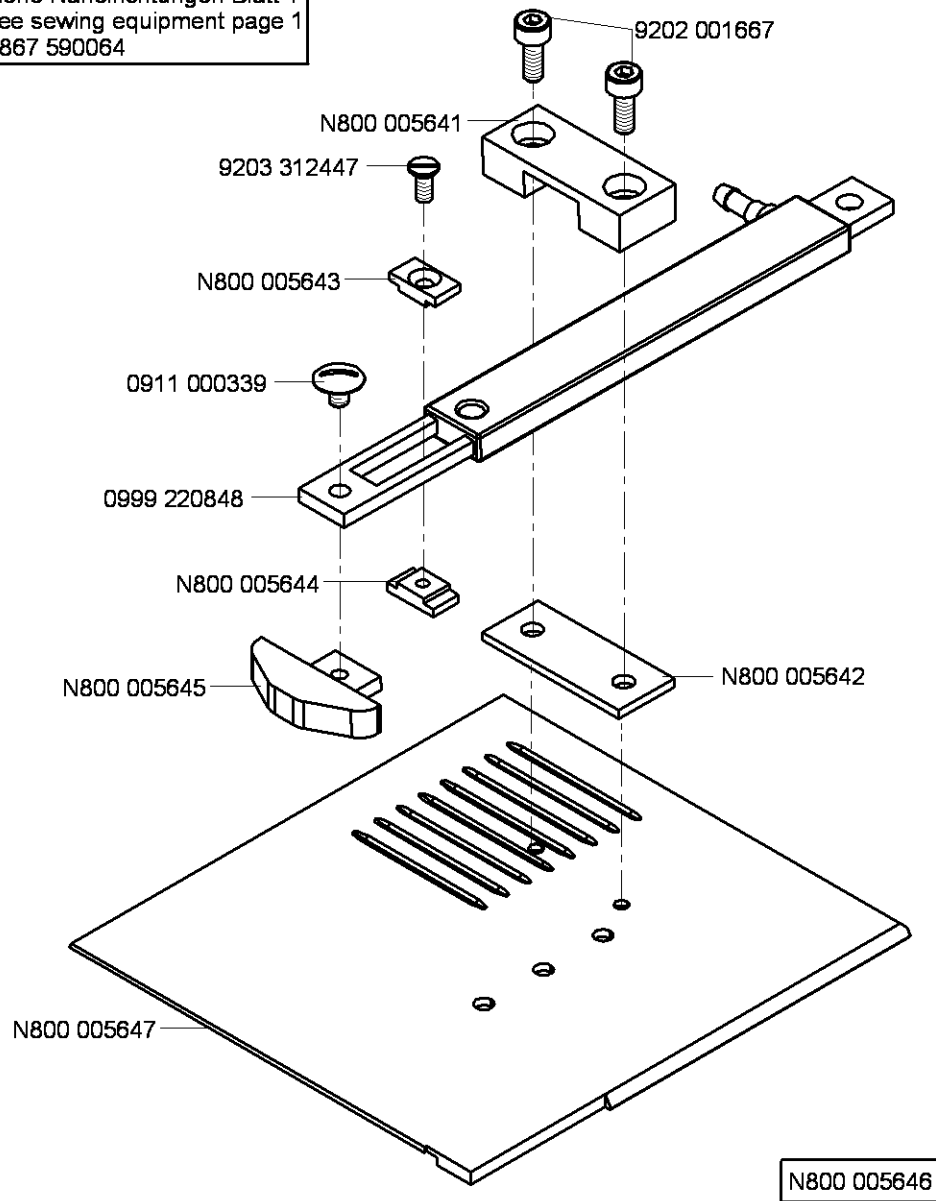

N800 005646

N - nicht als Einzelteil lieferbar
not available as separate part

siehe Näherichtungen Blatt 1
see sewing equipment page 1
0867 590064

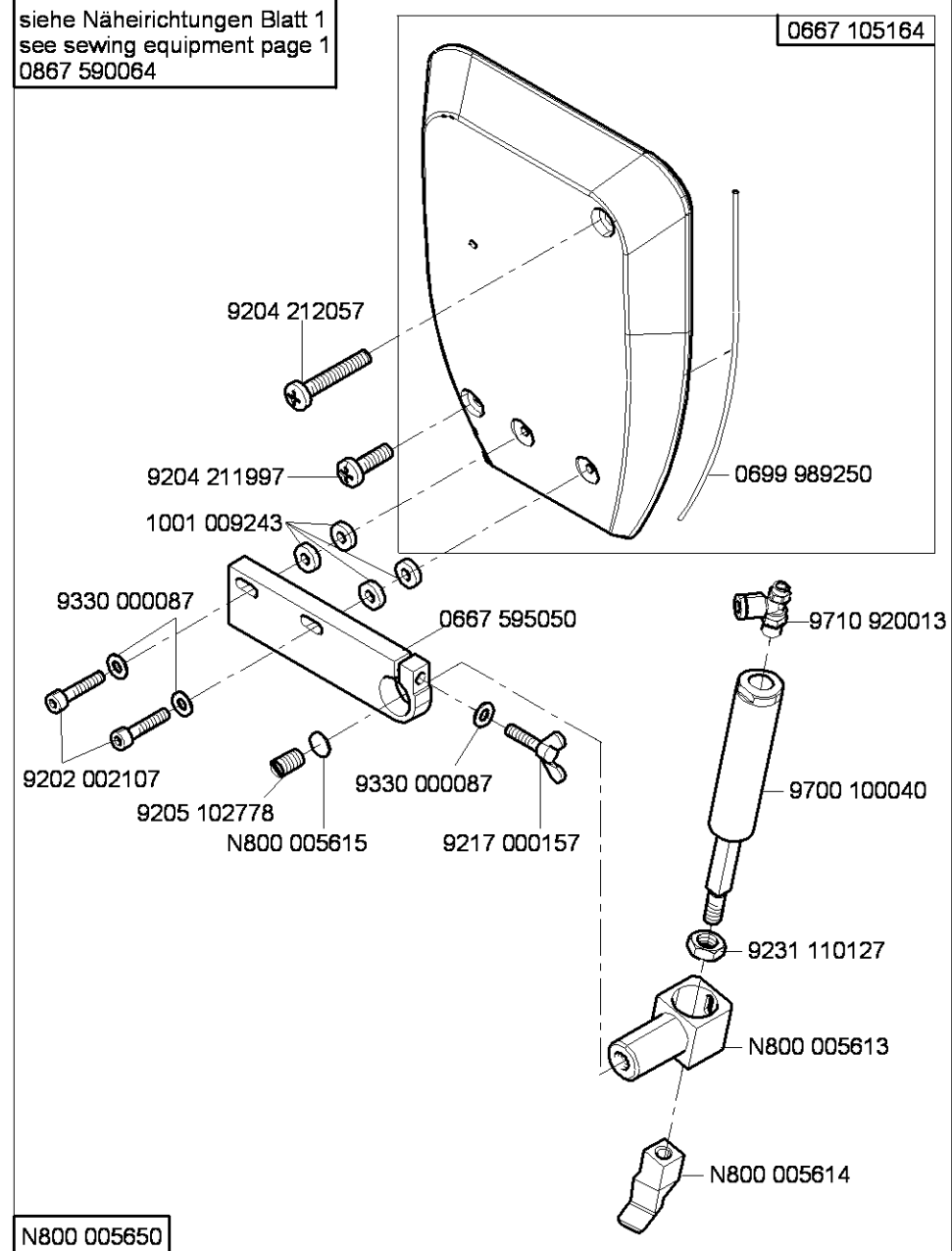

N800 005650

0667 105164

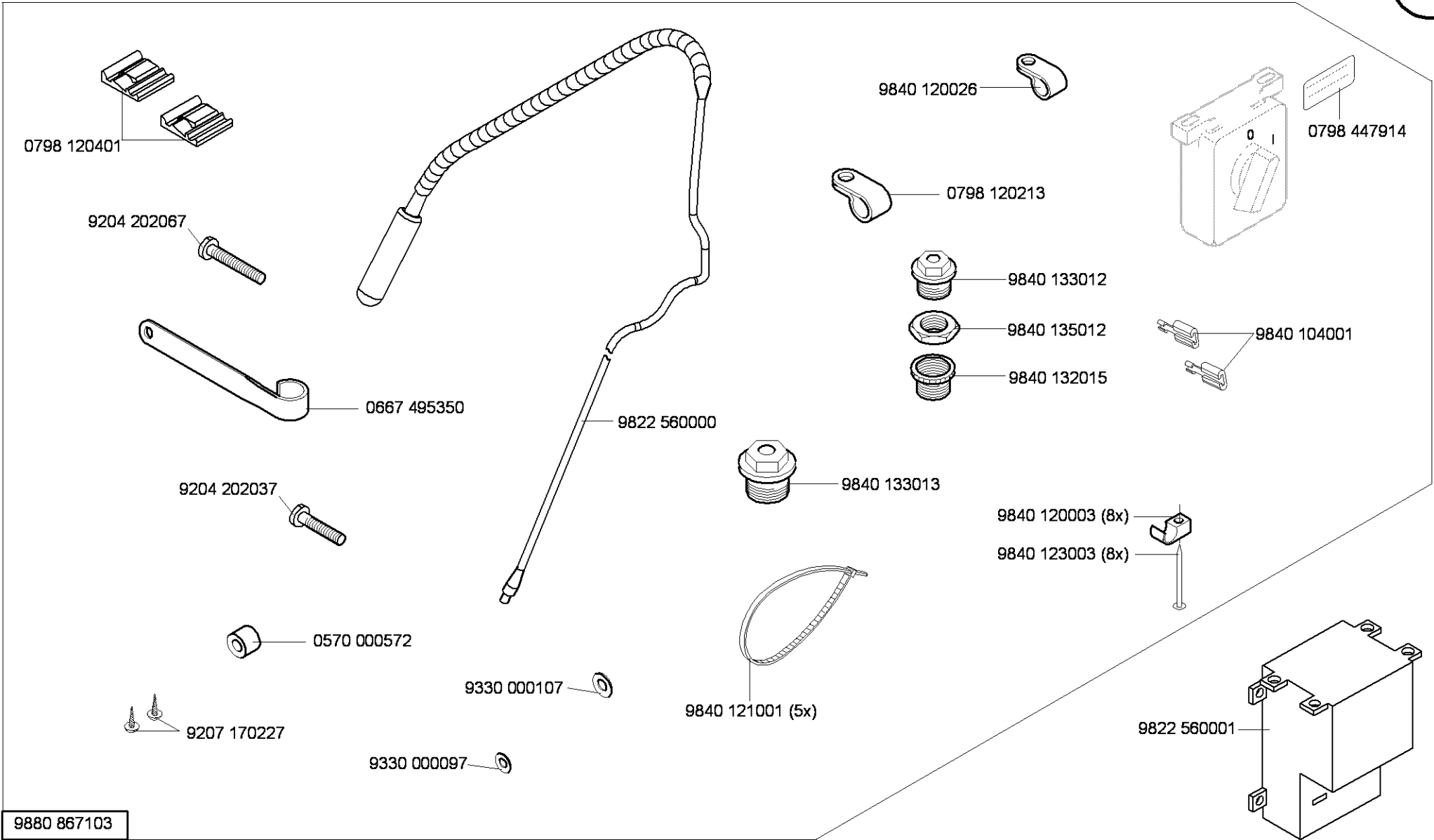

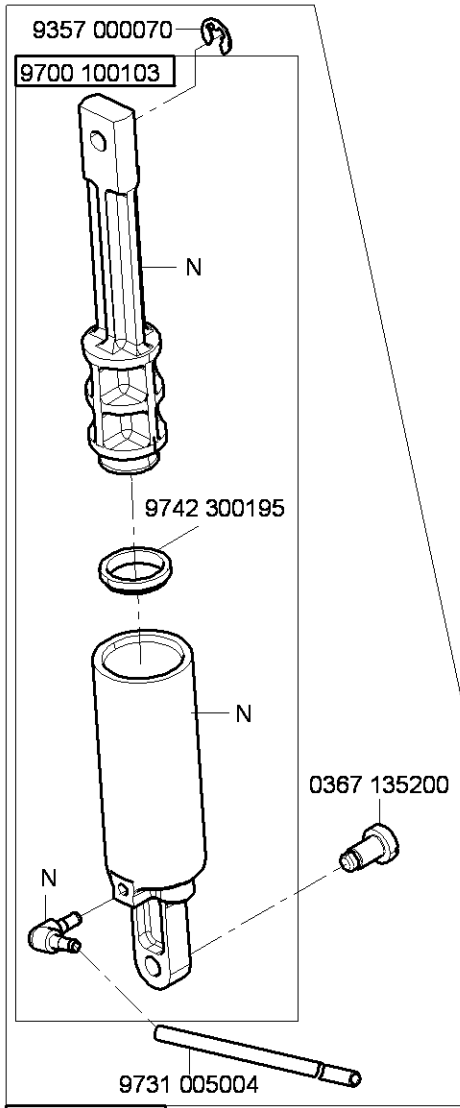

0667 135204 → 0867 590354
 → 0867 590364

N - nicht als Einzelteil lieferbar
 not available as separate part

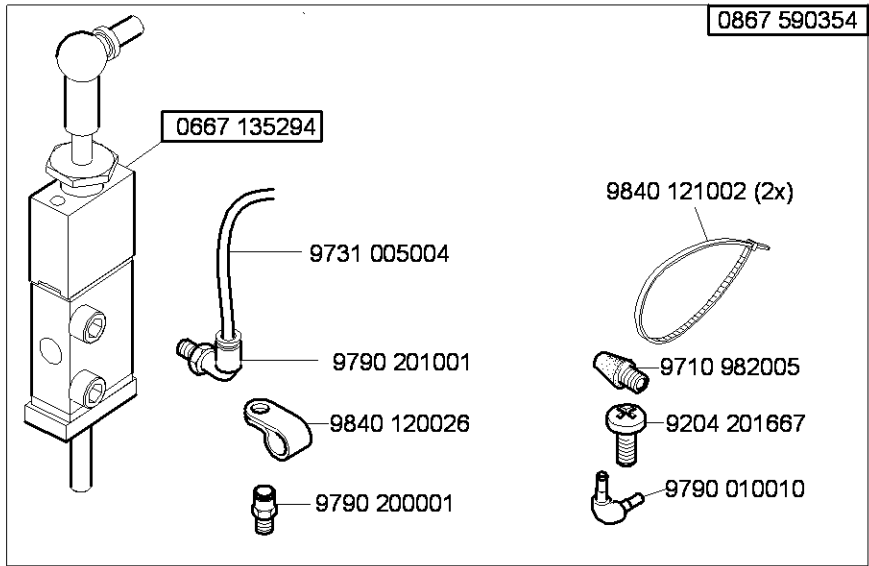

0867 590354

0867 590364 CI.867 -190020
 CI.867 -190040
 CI.867 -290020
 CI.867 -290040
 CI.867 -190020-70
 CI.867 -290020-70
 CI.867 -190040-70
 CI.867 -290040-70

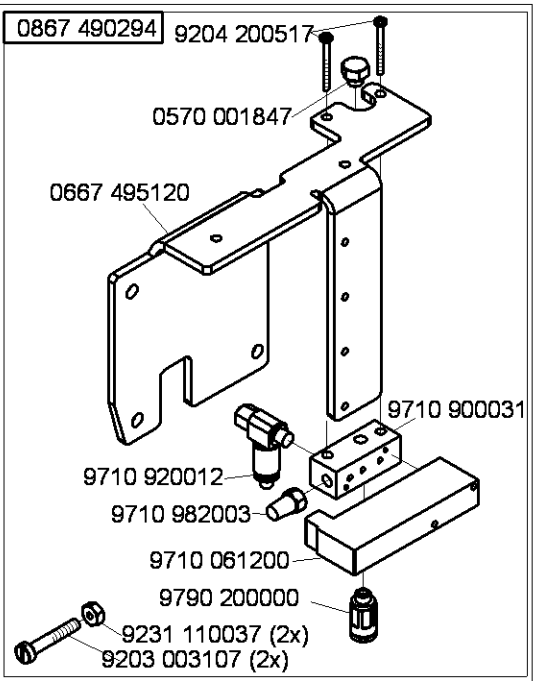
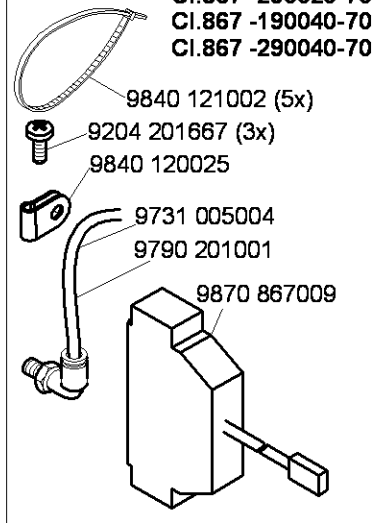

0867 490294 9204 200517

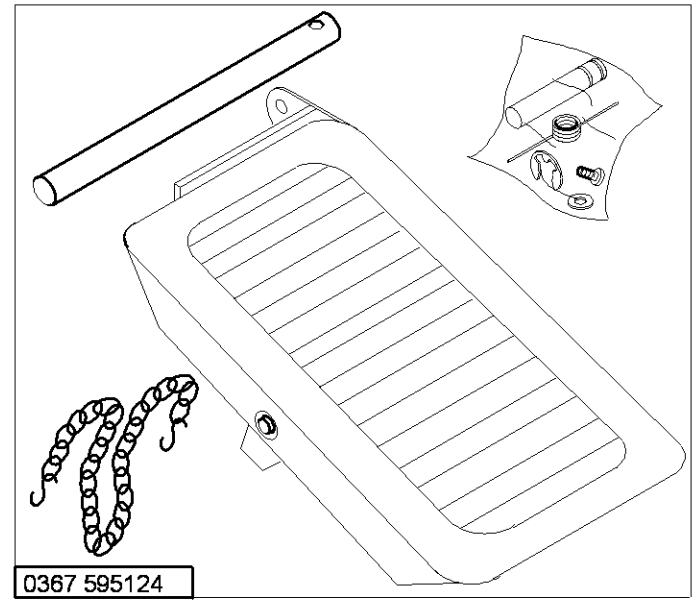

0367 595124

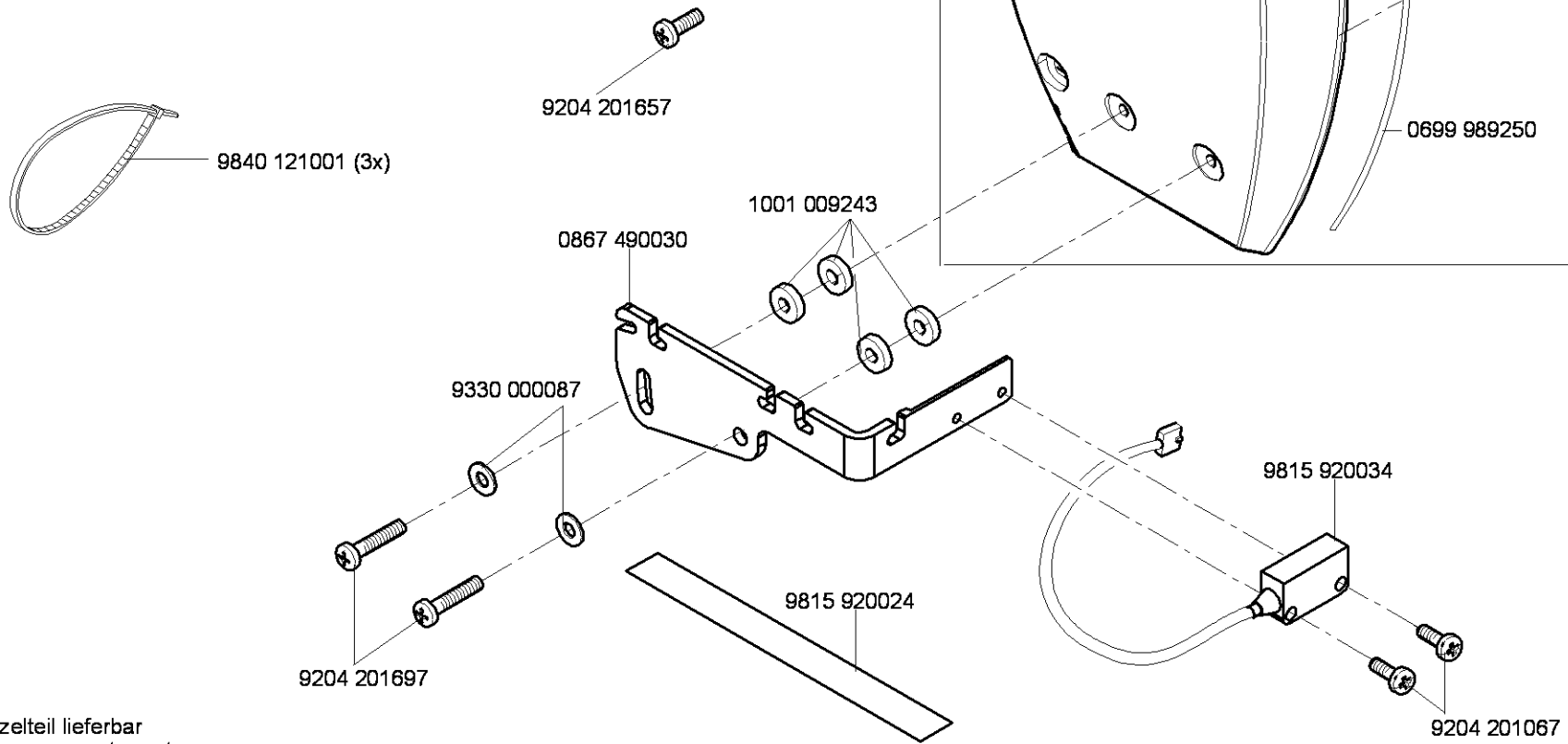

N - nicht als Einzelteil lieferbar
not available as separate part

0667 595204 für Cl.867 -190145 , Cl.867 -190125 auf Wunsch
for Cl.867 -190145 , Cl.867 -190125 on request

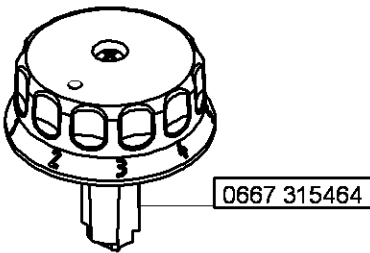
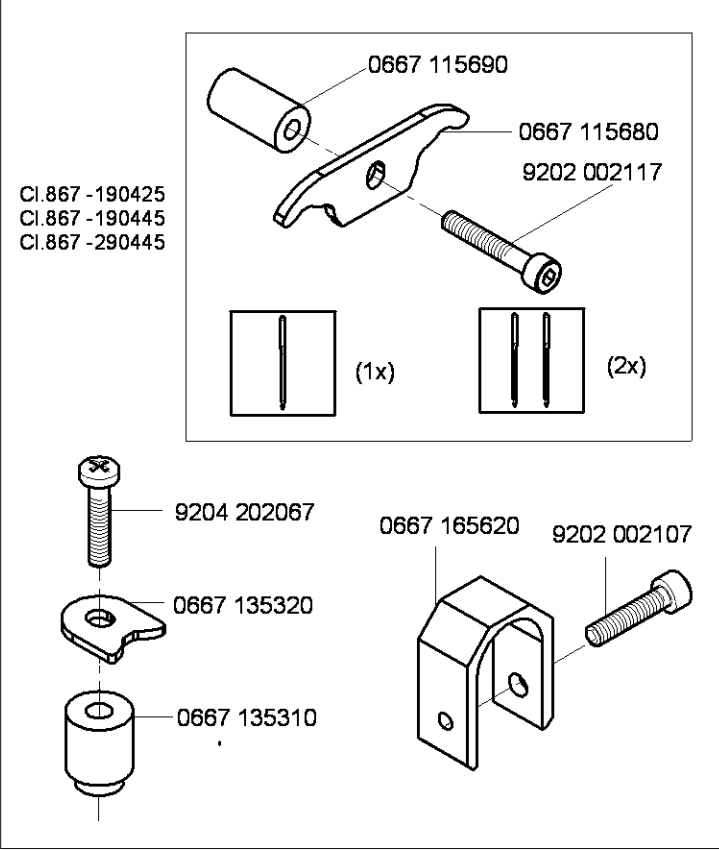
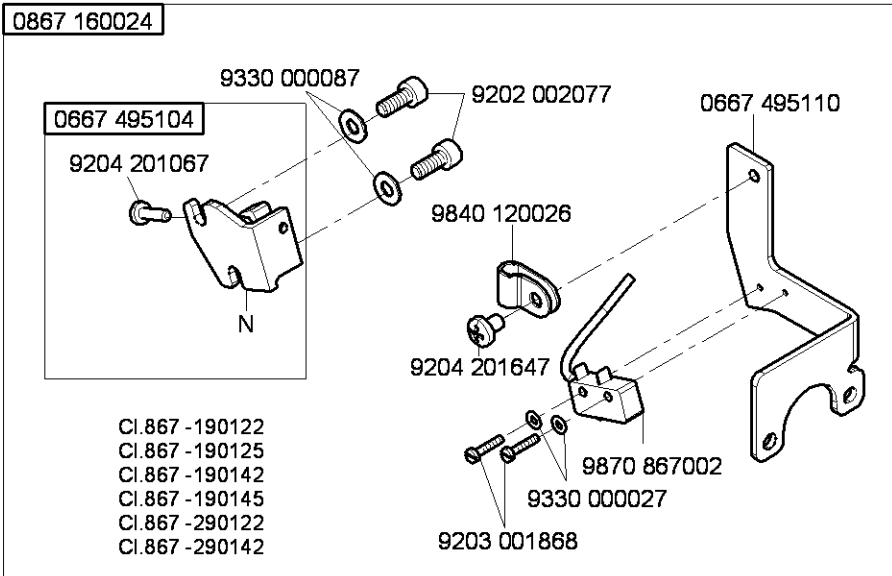

Teile-Nr./Part-No.	Tafel/Table	Teile-Nr./Part-No.	Tafel/Table	Teile-Nr./Part-No.	Tafel/Table	Teile-Nr./Part-No.	Tafel/Table	Teile-Nr./Part-No.	Tafel/Table
0002 007504 9500	56	0291 000334	32,33	0367 385133	3	0667 105320	42,44,45	0667 115530	26,27,28,29,30,31
0002 007504 8580*	56	0291 000347	42,43,44,45	0367 495010	42,43,44,45	0667 110340	42,43,44,45	0667 115570	29,30,31
0037 001280	26,27,28,29,30,31	0291 000537	40,41	0367 595124	74	0667 115070	26,29	0667 115580	29,30,31
0048 001814	67	0291 000538	40,41	0396 111320	66	0667 115080	26,29	0667 115590	26,27,28,29,30,31
0052 000369	66	0367 105083	6,7,8,9	0396 140050	53	0667 115090	26,29	0667 115600	26,27,28
0053 000350	26,29	0367 105180	6,7,8,9	0467 110220	26,27,28,29,30,31	0667 115094	29	0667 115610	26,27,28,29,30,31
0061 001050	26,27,28,29,30,31	0367 105910	56	0467 150040	15	0667 115110	29,31	0667 115620	26,27,28
0067 000903	67	0367 105950	66	0467 150120	15,16,20	0667 115120	26,28,29,31	0667 115630	26,27,28,29,30,31
0067 000904	67	0367 110340	26,27,28,29,30,31	0467 150130	15,16	0667 115130	26,29	0667 115640	26,27,28,29,30,31
0077 110230	66	0367 110360	26,27,28,29,30,31	0467 150440	15,16,17,18,19,20	0667 115134	26,29	0667 115680	76
0099 004910	26,27,28,29,30,31	0367 120100	3	0491 030652	8,34	0667 115140	26,29	0667 115690	76
0100 030590	59	0367 125020	6	0556 000821 A	32,33	0667 115150	26,29	0667 115730	42
0104 250010	66	0367 125194	3	0570 000572	73	0667 115160	26,29	0667 115743	42
0195 010111	54	0367 135200	13,74	0570 001847	36,37,38,39,44, 53,74	0667 115170	26,27,28,29,30,31	0667 115760	42,43
0211 000634	21,22	0367 140050	51,52	0667 100050	3,4	0667 115180	26,27,28,29,30,31	0667 115864	30,31
0211 000648	21,22	0367 145110	11	0667 105023	46,48,50	0667 115203	26,29,30,31	0667 115874	30,31
0211 000699	66	0367 145180	6,7,8,9	0667 105024	48	0667 115210	26,27,28,29,30,31	0667 125033	3
0211 004516	3	0367 150860	40,41	0667 105040	1	0667 115220	30,31	0667 125060	5
0216 000603	25	0367 165120	6,7,8	0667 105053	1	0667 115250	26,27,28,29,30,31	0667 125100	3
0219 000321	42,43,44,45	0367 165140	8	0667 105060	42,43,44,45	0667 115280	42,45	0667 125143	3
0223 000452	67,68	0367 165970	14,34	0667 105070	58,59,60,62	0667 115290	26,27,28,29,30,31	0667 125150	3
0223 000454	67,68	0367 240040	53	0667 105080	2	0667 115320	3	0667 125160	3
0223 000481	67,68	0367 240440	53	0667 105080	2	0667 115354	27,28	0667 125243	3
0223 000483	67,68	0367 240520	53	0667 105100	59,60	0667 115360	26,29	0667 125254	3
0244 000403	25	0367 240530	53	0667 105120	42,45	0667 115390	67	0667 135013	11
0244 000700	25	0367 240540	53	0667 105144	42,45	0667 115420	26,29	0667 135033	11
0244 014619	54	0367 240940	53	0667 105164	42,72,75	0667 115430	26,29	0667 135040	12
0245 001660 A	15,16	0367 250020	66	0667 105190	46,47	0667 115440	27,28	0667 135073	12
0265 000911	26,29	0367 315014	6,7	0667 105254	46	0667 115444	27	0667 135094	11
0271 000275	25	0367 315024	6,7	0667 105264	58,59,60,62	0667 115490	26,28	0667 135103	11
0271 001639	32,33	0367 315130	6,7	0667 105280	58,61,62	0667 115514	26	0667 135124	11
0291 000159	3	0367 315234	6,7	0667 105294	50	0667 115520	26,27,28,29,30,31	0667 135150	12

Teile-Nr./Part-No.	Tafel/Table	Teile-Nr./Part-No.	Tafel/Table	Teile-Nr./Part-No.	Tafel/Table	Teile-Nr./Part-No.	Tafel/Table	Teile-Nr./Part-No.	Tafel/Table
0667 135190	6,7	0667 155490	21,22	0667 160374	32,33	0667 170070	25	0667 315320	6,7
0667 135194	6,7	0667 155530	21,22	0667 160480	6,7,8	0667 170120	25	0667 315330	6,7
0667 135204	13,74	0667 155540	21,22	0667 165063	8	0667 175010	25	0667 315354	48,49
0667 135294	74	0667 155550	21,22	0667 165130	6,7	0667 175020	25	0667 315364	46,47,48,49
0667 135310	76	0667 155594	15	0667 165133	8	0667 175030	25	0667 315423	9
0667 135320	76	0667 155604	15	0667 165134	8	0667 175034	25	0667 315433	70
0667 145044	2,61	0667 155614	17	0667 165154	8	0667 175040	25	0667 315454	50
0667 145074	2	0667 155634	17	0667 165164	8	0667 175053	25	0667 315464	50,76
0667 145094	61	0667 155660	15	0667 165190	34	0667 175060	25	0667 355103	23
0667 145264	2	0667 155720	22	0667 165210	34	0667 175083	25	0667 355110	23
0667 145303	2	0667 155820	69	0667 165220	34	0667 175104	25	0667 355123	23
0667 145323	67	0667 155824	69	0667 165234	32,33	0667 175114	25	0667 355130	23
0667 145354	67	0667 155830	69	0667 165243	32,33	0667 235010	3	0667 355140	23
0667 145390	51,52	0667 155840	44,53,69	0667 165250	32,33	0667 245003	71	0667 355150	23,24
0667 145410	67	0667 155854	69	0667 165260	32,33	0667 245004	71	0667 355173	23
0667 145464	2	0667 155893	21,22	0667 165273	32,33	0667 245010	71	0667 355174	23
0667 150830	17,18,19,20	0667 155900	21,22	0667 165284	32,33	0667 310563	6,7	0667 355240	40,41
0667 150840	17,19,20	0667 155930	44,53,69	0667 165290	32,33	0667 315053	6,7	0667 355260	24
0667 150850	17,18,19,20	0667 155940	2	0667 165304	32,33	0667 315113	6,7	0667 355270	24
0667 150860	17	0667 155950	21	0667 165354	33	0667 315150	6,7,8,9,11	0667 355283	24
0667 150870	17,18,19,20	0667 156014	69	0667 165370	8	0667 315164	6,7	0667 355300	24
0667 150880	69	0667 156034	19	0667 165390	9	0667 315174	14	0667 355310	24
0667 155100	21,22	0667 156044	19	0667 165403	9,10	0667 315203	5	0667 355324	24
0667 155114	21	0667 156130	15,16	0667 165423	9,10	0667 315213	5	0667 355343	24
0667 155390	21,22	0667 156180	17,18,19	0667 165454	9	0667 315223	5	0667 355344	24
0667 155403	21,22	0667 156190	15,16,20	0667 165500	9,10	0667 315243	5	0667 355363	24
0667 155424	21,22	0667 156210	17,18,19,20	0667 165550	8	0667 315253	5	0667 355410	24
0667 155440	21	0667 156320	15,16	0667 165560	67	0667 315280	6,7	0667 355420	23,24
0667 155450	22	0667 156330	17,18,19,20	0667 165570	34	0667 315290	6,7	0667 385013	6,7,8
0667 155460	21,22	0667 156440	17,18,19	0667 165580	8	0667 315300	46,47,48,49,50	0667 385033	40,41
0667 155474	21	0667 160170	32,33	0667 165620	76	0667 315310	6,7	0667 385070	42
0667 155484	22	0667 160350	32,33	0667 165700	34	0667 315314	6,7	0667 385143	40,41

Teile-Nr./Part-No.	Tafel/Table	Teile-Nr./Part-No.	Tafel/Table	Teile-Nr./Part-No.	Tafel/Table	Teile-Nr./Part-No.	Tafel/Table	Teile-Nr./Part-No.	Tafel/Table
0667 385174	40,41	0699 989250	42,44,45,46,47, 48,49,50,54,72,75	0818 160210	8	0867 120280	4	0867 150214	20
0667 385180	42,45			0867 100030	55	0867 120294	44	0867 150323	21
0667 385220	40,41	0700 000043	63,64	0867 100043	48	0867 120300	4	0867 150333	22
0667 495093	36,37,38,39	0700 000044	63,64	0867 100044	48	0867 120320	44	0867 150343	21,22
0667 495104	33,76	0700 000045	63,64	0867 100050	43	0867 120340	4	0867 152050	2
0667 495110	33,76	0700 000050	63,64	0867 102043	47,49	0867 120350	4	0867 160024	76
0667 495120	74	0700 000090	66,68	0867 102044	49	0867 120360	4	0867 160620	6,7,8
0667 495290	36,37,38,39	0700 000091	66	0867 102244	47	0867 120370	4	0867 160630	6,7,8
0667 495304	42,43,45,71	0700 086702	63	0867 102353	47,49	0867 120380	4	0867 160640	6,7
0667 495350	73	0700 086704	63	0867 102360	45	0867 120390	44	0867 162034	35
0667 595050	72	0700 086764	64	0867 102370	1	0867 120400	4	0867 162040	35
0667 595204	76	0700 086766	64	0867 110014	43	0867 120410	4	0867 162043	35
0688 100050	61	0725 000520 B	58,59,60,62	0867 110020	43	0867 120420	4	0867 162053	11
0688 100124	61	0742 002096	65	0867 110034	28	0867 120423	4	0867 162064	35
0688 100173	1	0744 001155	27,28,30,31	0867 110050	43	0867 120440	4	0867 162070	35
0688 130260	12	0744 001793 A	65	0867 120024	4	0867 120520	44	0867 162160	35
0688 130280	11	0744 001793 B	65	0867 120043	4	0867 120533	4	0867 162173	8
0688 130290	11	0744 001796	65	0867 120070	4	0867 120564	44	0867 172014	2
0688 130363	67	0767 150170	69	0867 120080	4	0867 120574	44	0867 210060	70
0688 130384	67	0767 150590	15,16,17,18,19,20	0867 120090	4	0867 122043	3	0867 210100	70
0688 140060	61	0791 000007	66	0867 120100	4	0867 132063	68	0867 310430	6,7
0688 140070	61	0791 001081	66	0867 120110	4	0867 132070	68	0867 310440	6,7
0688 350254	23	0791 001094	66	0867 120120	4	0867 132084	68	0867 312034	14
0688 350264	23	0791 001096	66	0867 120130	4	0867 132093	68	0867 312050	7
0688 380040	40,41	0791 580100	66	0867 120140	4	0867 132113	68	0867 312070	7
0688 380120	67,68	0797 003031	65	0867 120150	4	0867 132133	11	0867 330013	54
0688 380130	40,41	0798 000677	58,59,60,61,62	0867 120160	4	0867 132143	11	0867 330020	54
0688 380140	67,68	0798 003292	57,61	0867 120170	4	0867 140030	51,52	0867 330040	55
0688 380163	4	0798 120213	73	0867 120220	44	0867 140704	61	0867 330060	54
0699 979104	12,21,22,40,41	0798 120401	70,73	0867 120233	44	0867 140724	61	0867 330063	54
0699 979265	69,70	0798 447914	56,73	0867 120250	44	0867 142164	68	0867 330070	54
		0798 500088	56	0867 120270	44	0867 150204	20	0867 330103	54

Teile-Nr./Part-No.	Tafel/Table	Teile-Nr./Part-No.	Tafel/Table	Teile-Nr./Part-No.	Tafel/Table	Teile-Nr./Part-No.	Tafel/Table	Teile-Nr./Part-No.	Tafel/Table
0867 330110	54	0867 590024	70	0868 310090	6,7	0999 220752	40,41	9129 024235	3,4
0867 330120	54	0867 590054	70	0887 380010	40	0999 220848	72	9130 104205	62
0867 330133	54	0867 590104	69	0891 003342	36,37,38,39,44,53	0999 220851	44	9130 104213	60
0867 330150	54	0867 590114	69	0902 000423	51,52	0999 240376	22	9130 104220	58
0867 330160	54	0867 590124	69	0902 004102	4	0999 240389	69,70	9130 104225	58,59
0867 330170	54	0867 590134	69	0906 020164	64	0999 240394	70	9130 104230	59
0867 330180	54	0867 590354	74	0907 030200	64	0999 240408	38,39,55	9130 104240	59
0867 330200	54	0867 590364	74	0907 030410	64	1001 001162	42,43,44,45	9130 221130	2
0867 330230	54	0867 590464	34	0907 030484	58	1001 009243	53,72,75	9130 221140	61,62
0867 330253	54	0867 590503	53	0907 030494	59	6279 140164	2	9130 221250	55
0867 330263	55	0867 590510	53	0911 000290	42,43	9041 100015	6,7,8	9130 221290	61,62
0867 330310	54	0867 590523	53	0911 000339	72	9041 100025	3	9130 500050	60
0867 330314	54	0867 590533	53	0911 000478	69,70	9041 100030	21,22	9130 500070	58,59,60
0867 330340	54	0867 590553	53	0913 000731	66	9041 100035	40,41	9130 500090	59
0867 330510	54	0867 590560	53	0916 030364	64	9041 100203	40,41,66	9130 500110	58,59
0867 330513	54	0867 590574	53	0917 030510	64	9081 200250	66	9130 500130	59
0867 330580	54	0867 590583	53	0933 001544	40,41	9081 200303	66	9130 500750	62
0867 330704	54	0867 590590	53	0965 000511	53	9081 200500	66	9130 500770	62
0867 350083	24	0867 590600	53	0990 254306	57	9081 500010	66	9150 010090	53
0867 380010	43	0867 590610	53	0992 016580	15,16,17,18,19,20	9081 500051	66	9190 100105	68
0867 380020	41	0867 590620	53	0992 023560	15,16,17,18,19,20	9122 200121	54	9190 100113	67
0867 382014	40	0867 590634	53	0992 023577	15,16,17,18,19,20	9122 200161	1	9190 100155	46,48,50
0867 490010	67	0867 590640	44,53	0993 904247	66	9122 322200	5	9190 100226	21,22
0867 490030	75	0867 590650	10	0994 270980	64	9126 102500	7	9190 400120	32
0867 490084	44	0868 150400	16	0995 340617	66	9126 102520	6,7,8,32,33	9199 000004	36,37,39
0867 490130	53	0868 150414	16	0996 120387	53	9126 102540	6,8,32,33	9201 013767	60,62
0867 490144	53	0868 150434	16	0998 881010	21,22	9126 200064	54	9201 113277	67,68
0867 490154	53	0868 150450	18	0998 881610	6,7,34	9126 300061	21,22,54	9201 113317	61
0867 490164	53	0868 150464	18	0998 912080	3	9126 300073	53	9201 113677	67,68
0867 490180	43	0868 150484	18	0998 912110	21,22	9126 300088	21,22	9201 113767	59
0867 490294	74	0868 310080	6,7	0999 201114	51,52	9126 300089	54	9201 113777	58
0867 590014	70	0868 310084	6,7	0999 210839	53	9126 300220	11	9202 001653	15,17

Teile-Nr./Part-No.	Tafel/Table	Teile-Nr./Part-No.	Tafel/Table	Teile-Nr./Part-No.	Tafel/Table	Teile-Nr./Part-No.	Tafel/Table	Teile-Nr./Part-No.	Tafel/Table
9202 001658	4	9202 022477	23,24	9204 201647	26,27,28,29,30,	9205 102477	2,3,4,6,7,9,15,16,	9231 110108	54
9202 001667	44,72	9202 022497	23		31,33,42,43,44,		17,18,19,20,26,	9231 110127	64,68,72
9202 001678	3,25	9202 042067	53		45,51,52,54,55,		29,32,33,59,60,61	9234 000067	32,33,43
9202 002057	6,7,8,34,44,53	9202 100537	23,42,51,52	9204 201657	71,76	9205 102487	7	9301 100941	4
9202 002058	9,10	9202 100538	24	9204 201667	3,61,75	9205 102513	32,33	9301 100991	4
9202 002067	40,41,68	9203 001807	4	9204 201677	3,4,25,35,36,37,	9205 102778	72	9301 101001	4
9202 002077	21,22,24,32,33,	9203 001827	4	9204 201697	38,39,40,41,42,	9205 102798	11	9301 101561	23
	40,42,43,44,45,	9203 001868	33,76	9204 201698	43,44,45,53,69,74	9205 121558	21,22	9301 102203	6,7
	53,55,56,61,67,	9203 003077	70	9204 201699	44,53	9205 122488	21,22	9301 102471	35
	68,69,71,76	9203 003097	69,70	9204 201827	62,75	9205 162597	12	9301 200660	21,22
9202 002078	3	9203 003107	74	9204 201827	66	9206 100637	40,41,67,68	9302 000100	40,41
9202 002087	33,34,40,41,54,67	9203 003137	44,53	9204 201977	59	9207 150207	67	9303 502990	61
9202 002097	24,32,33,53,56	9203 003157	69,70	9204 202037	44	9207 161237	66	9305 001680	64
9202 002098	5,8,11,23,24,32,	9203 003167	44	9204 202067	73	9207 170227	44,53,58,59,60,	9305 100350	26,27,28
	33,35	9203 003177	54	9204 211997	73,76		61,62,63,64,73	9305 100370	29,30,31
9202 002107	23,24,40,72,76	9203 003637	53		2,6,7,8,32,33,42,	9207 170437	42,43,44,45,56,	9330 000027	4,33,76
9202 002117	35,76	9203 003797	64	9204 301467	44,45,46,47,48,		58,59,66,71	9330 000067	26,27,28,29,30,31
9202 002377	53	9203 100002	26,27,28,29,30,	9204 301487	49,50,61,67,72	9207 170847	58,59	9330 000087	3,5,8,24,26,27,28,
9202 002497	7,42,43,44,53,54		31,36,37,38,39,	9204 302217	36,37,38,39,44,53	9207 170857	61		29,30,31,32,33,
9202 002507	61		44,53	9204 431657	25	9207 171057	63		44,53,59,61,67,
9202 002517	53	9203 211830	15,16,17,18,19,20	9205 101568	14,33,34	9207 171067	64		68,71,72,75,76
9202 002527	54	9203 312412	3	9205 101827	27,28,30,31,43	9217 000117	53	9330 000088	21,22,53,66
9202 002877	71	9203 312447	72	9205 101868	69	9217 000157	72	9330 000097	2,54,61,73
9202 002887	54	9203 313047	53,70	9205 101958	3,53	9217 300507	4,26,28,29,31,55	9330 000098	23
9202 002888	32,33	9204 002363	51,52	9205 102188	42,43	9225 201750	3	9330 000107	61,64,73
9202 002898	21,22	9204 101657	6,7	9205 102303	24	9225 201770	26,27,28,29,30,	9330 000127	12
9202 002908	21,22	9204 200447	36,39	9205 102450	4		31,42,43,45,56	9330 000177	66
9202 002917	53	9204 200517	36,37,38,39,44,	9205 102467	6,7	9231 000367	24	9330 200107	23,24
9202 002918	6,7		53,69,70,74	9205 102473	21,54,55	9231 000387	11,53,54	9330 200117	21,22,53
9202 002927	11,65	9204 201067	25,33,36,37,38,		1,2,3,5,6,7,8,9,10,	9231 000388	24	9330 300027	58,59,60,62
9202 003017	54		39,75,76		11,12,14,21,22,	9231 011137	67,68	9330 700107	46,47,48,49,50
9202 003738	42,43,44,45				23,24,32,33,54	9231 110037	25,74	9330 900093	67,68
9202 022467	40,41					9231 110057	59,64		

Teile-Nr./Part-No.	Tafel/Table	Teile-Nr./Part-No.	Tafel/Table	Teile-Nr./Part-No.	Tafel/Table	Teile-Nr./Part-No.	Tafel/Table	Teile-Nr./Part-No.	Tafel/Table
9330 900117	63,64	9700 100102	53	9790 200000	36,37,38,39,74	9815 310009	36,37,38,39	9840 120026	33,40,41,42,43, 44,45,56,71,73, 74,76
9332 500137	26,28,29,31	9700 100103	13,74	9790 200001	74	9815 580001	58	9840 120030	66
9333 000090	51,52	9700 212044	54	9790 201000	36,37,38,39,44, 53,54	9815 920024	75	9840 120060	58,59,60,61,62
9334 000051	21,22	9710 061200	36,37,38,39,44, 53,69,70,74	9790 201001	67,74	9815 920034	75	9840 120104	24,40,41
9334 001620	53	9710 063000	54	9790 202000	44,53	9815 925002	69	9840 120105	34,40,41
9334 001630	3,6,7,8,12,25,32, 33,54	9710 900011	36,39	9790 315002	69	9822 510001*	56	9840 120106	69
9334 001640	4,5,9,10,53,54	9710 900031	69,70,74	9800 110002 A	57	9822 510003**	56	9840 121001	14,41,42,43,44, 45,53,56,66,70, 71,73,75
9352 000120	54	9710 900032	44,53	9800 110002 D	57	9822 510012 *	56	9840 121002	69,70,74
9352 640050	67,68	9710 900037	36,37,39	9800 120017 A	57	9822 510013 **	56	9840 123003	14,42,43,44,45, 56,58,59,60,61, 62,66,71,73
9353 000087	21,22	9710 900041	54	9800 130104 R	61	9822 560001	73	9840 130007	40,41
9353 000350	2	9710 900073	38	9800 130105	61	9822 610000 **	56	9840 130008	40,41
9353 000420	2	9710 920012	36,37,38,39,44, 53,54,70,74	9800 310006	57	9822 642024 *	56	9840 132015	42,43,44,45,56, 71,73
9353 000470	1,2	9710 920013	72	9800 310007	57	9822 642027 **	56	9840 133012	42,43,44,45,56, 66,71,73
9354 010150	54,55	9710 982003	36,37,38,39,44, 53,54,74	9800 327001	57	9825 190400	58,59	9840 133013	42,43,44,45,56, 71,73
9354 010210	2,61	9710 982005	74	9800 327005	61,62	9825 190104	57	9840 135012	42,43,44,45,56, 66,71,73
9354 400800	4,21,22,40,41	9710 982005	74	9800 330001	57	9825 190502	58,59	9850 001075	71
9357 000050	23,24	9731 001035	40,41	9800 330002	57	9825 550001	36,37,38,39	9850 001083	66
9357 000060	53,54	9731 002001	65	9800 330006	57	9825 810302	56	9850 001089	66
9357 000070	6,7,8,12,13,14,21, 22,25,32,33,44, 54,74	9731 005004	13,14,27,28,30, 31,33,34,36,37, 38,39,44,53,55, 70,74	9800 330009	57	9825 810319	57	9850 867000	36,37,38,39
9357 000080	9,10,26,29,54			9800 330010	57	9825 810401	66,71	9850 867001	40,41
9357 000090	5,6,7	9731 007035	3	9800 330011	57	9825 810412	57	9850 867003	69
9357 000100	32,33,68	9740 000607	46,47,48,49,50	9800 330012	61	9825 810417	61	9850 867006	44,53
9357 000129	6,7,8,32,33	9742 300100	53	9800 330016	62	9830 501010	36,37,38,39,44, 53,69	9870 001003	58
9357 000173	11	9742 300190	14	9800 331104	61	9830 502005	40	9870 001004	58
9357 200056	64	9742 300195	13,74	9800 360050	57	9830 502014	40,41	9870 001024	59
9380 521220	67	9780 000108	65	9815 301079	36,37,38,39	9840 104001	42,43,44,45,56, 71,73		
9400 000090	51,52	9790 000220	70	9815 301081	36,37				
9700 100040	72	9790 010010	30,31,74	9815 301090	36,37,38,39	9840 120001	58,59,60,61,62		
9700 100094	14	9790 030020	69	9815 301091	36,37,38,39	9840 120003	14,42,43,44,45, 56,66,71,73		
9700 100100	33,34			9815 301096	36,37				
				9815 310008	36,37,38,39	9840 120025	14,69,74		

Teile-Nr./Part-No.	Tafel/Table	Teile-Nr./Part-No.	Tafel/Table	Teile-Nr./Part-No.	Tafel/Table	Teile-Nr./Part-No.	Tafel/Table	Teile-Nr./Part-No.	Tafel/Table
9870 001025	59	MG46 000401	57	Z132 001452	70				
9870 001112	14	MG53 002501	63						
9870 001113	66	MG53 007511	63						
9870 367003	69,70	MG53 007921	65						
9870 767019	59,62	MG53 007922	65						
9870 867000	61,62	MG55 000501	63						
9870 867001	23,24	MG58 000505	64						
9870 867002	33,76	N800 005216	53						
9870 867003	69	N800 005219	53						
9870 867006	59,60	N800 005266	53						
9870 867007	23	N800 005267	53						
9870 867008	53	N800 005613	72						
9870 867009	74	N800 005614	72						
9870 867010	44	N800 005615	72						
9880 001001	61	N800 005641	72						
9880 001003	60,62	N800 005642	72						
9880 867010	62	N800 005643	72						
9880 867011	62	N800 005644	72						
9880 867012	62	N800 005645	72						
9880 867100	56	N800 005646	72						
9880 867101	36,37	N800 005647	72						
9880 867102	42,43,45,71	N800 005650	72						
9880 867103	73	N800 075013	71						
9880 867105	14	N800 080001	71						
9880 867107	36,37	N800 080003	71						
9880 867108	14	N800 080004	71						
9880 867110	38,39	N800 080021	71						
9880 867113	44	N800 080022	71						
9880 867114	44	S283 003002	35						
MG43 000062	63,64	S321 833821	68						
MG43 000410	58	S443 000006	68						
MG43 000484	61	Z100 011022	21,22						

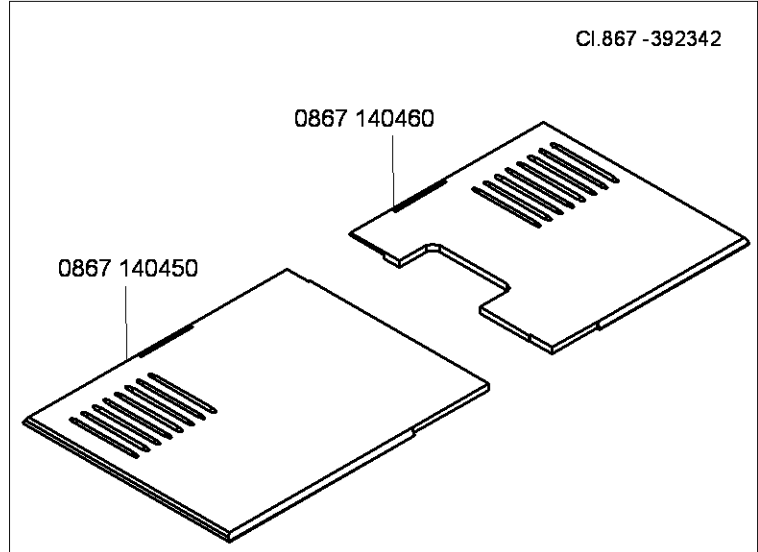
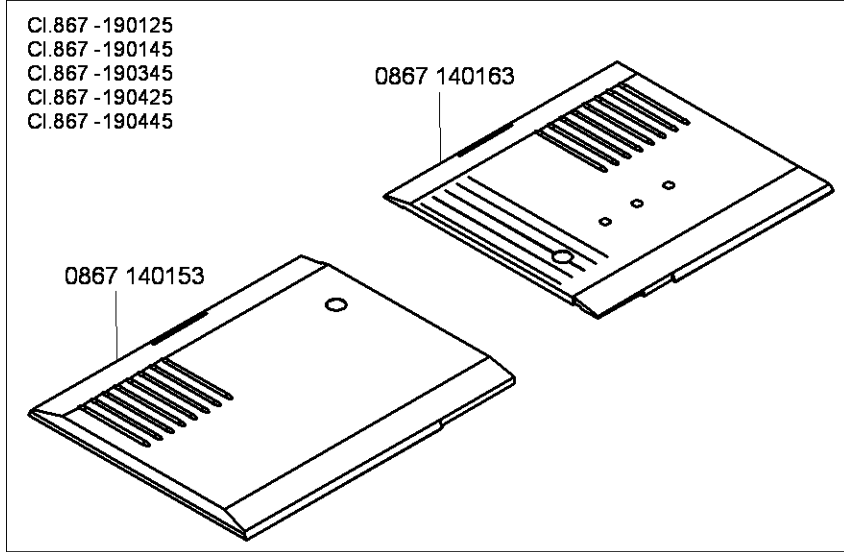
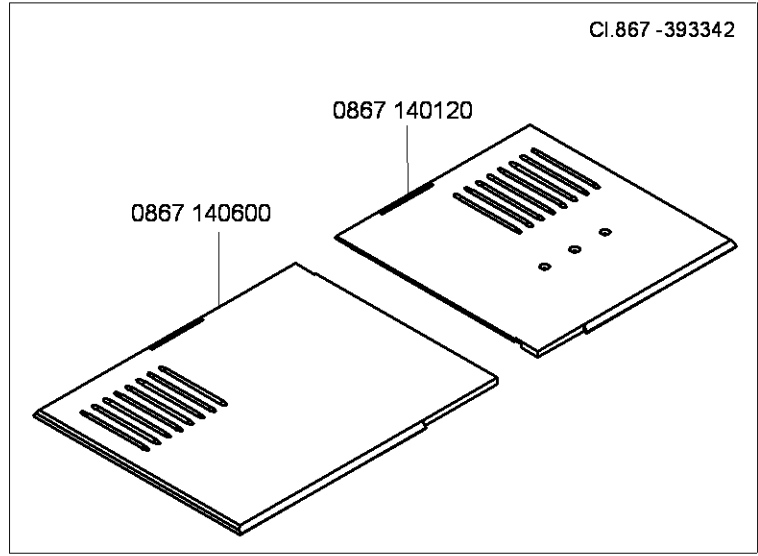
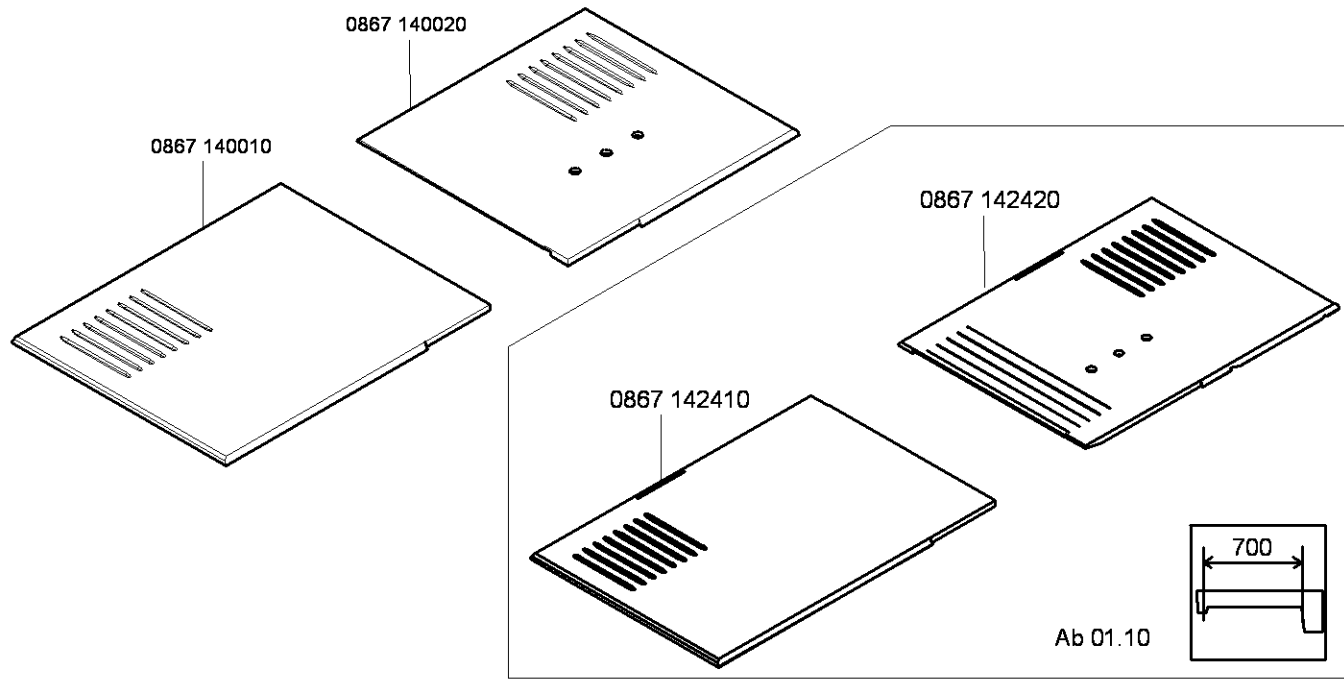

Befestigungsteile für Nähmaschinen
Fastening parts for Sewing equipment

* bis 12.07 - 211 1033

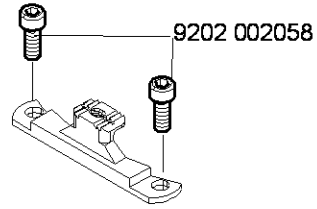
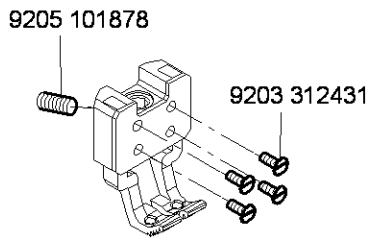
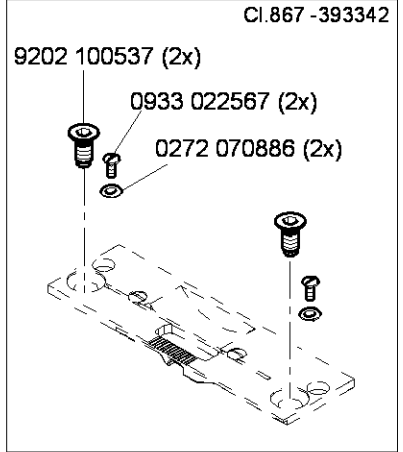
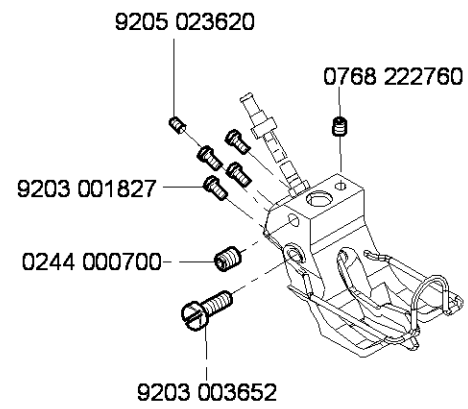
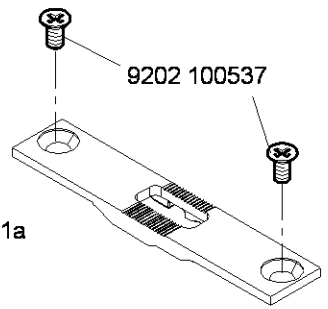
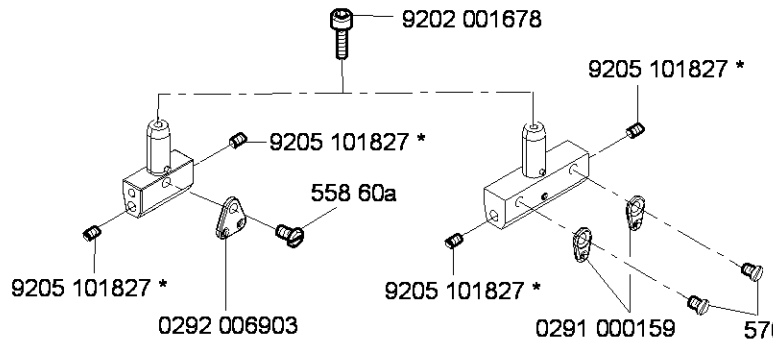
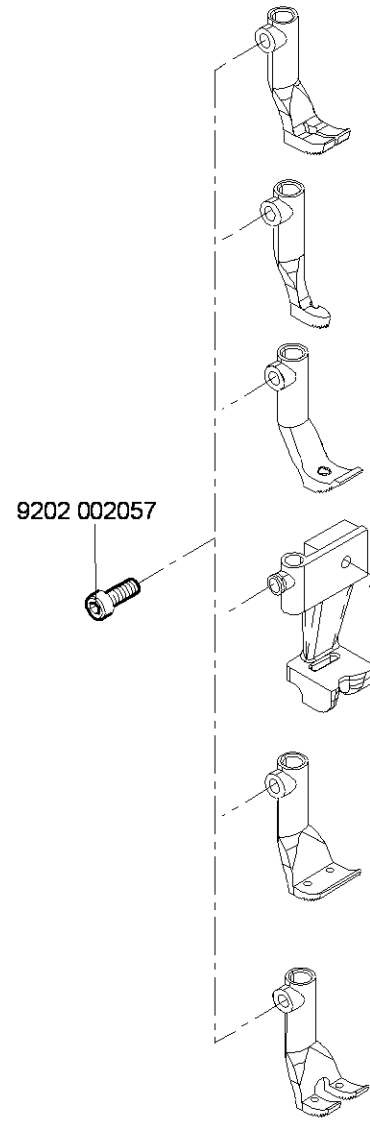
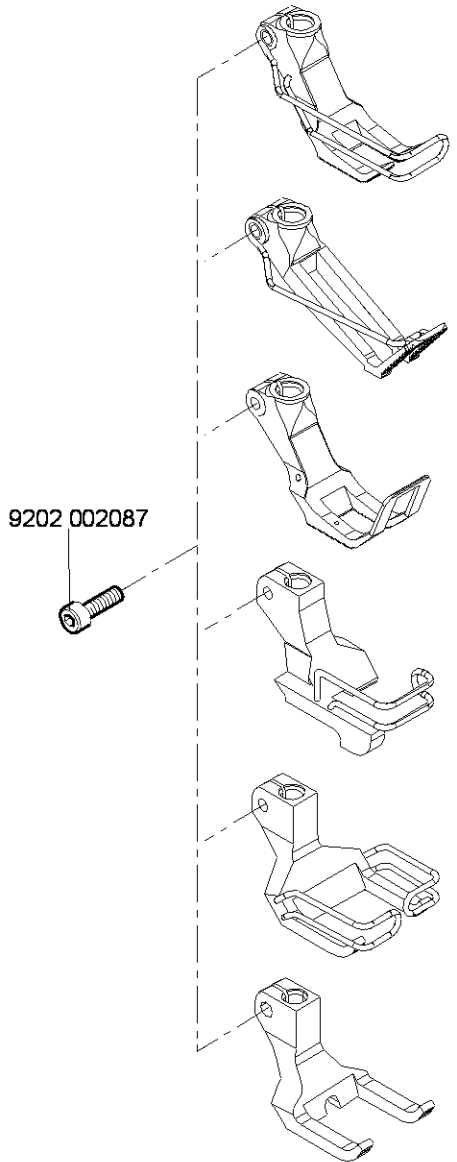



Pneumatische Anschluss/Pneumatic connection

Die Näheinrichtungen: E24/6/9, E24/8/9, E24/10/9, E24/12/9, E24/8/12, E24/10/12, E24/12/12, E24/14/12, beinhalten auch die unten abgebildete Komponente.

The following sewing equipments: E24/6/9, E24/8/9, E24/10/9, E24/12/9, E24/8/12, E24/10/12, E24/12/12, E24/14/12, include also the below reproduced component.

0867 590064

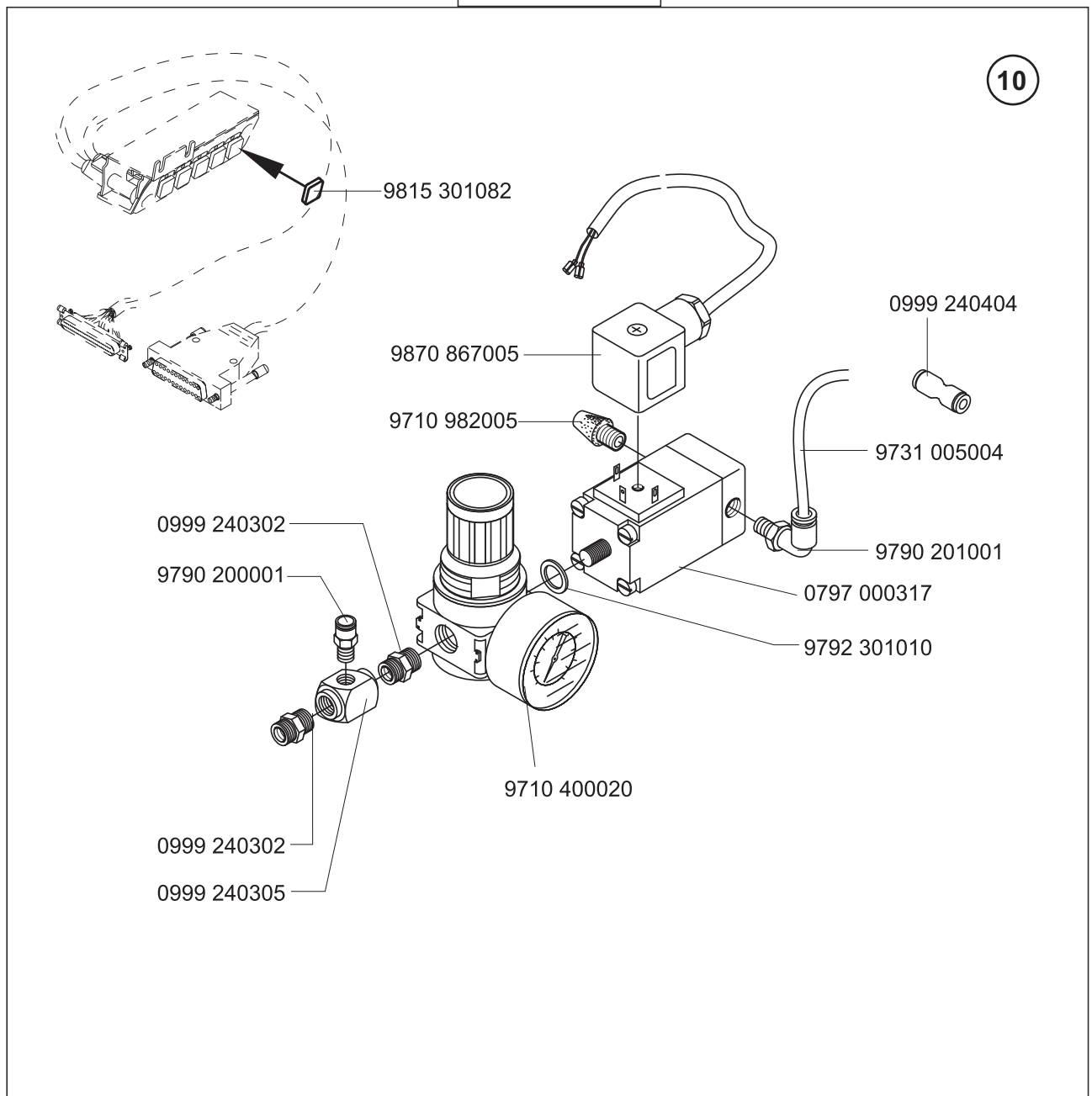



E1

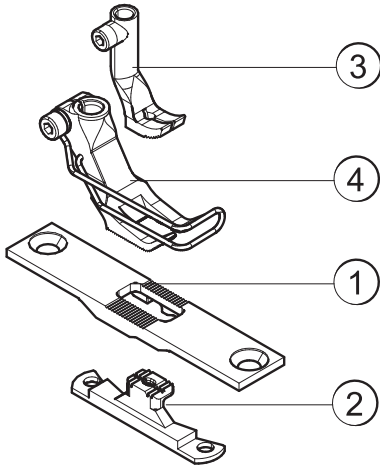

E2

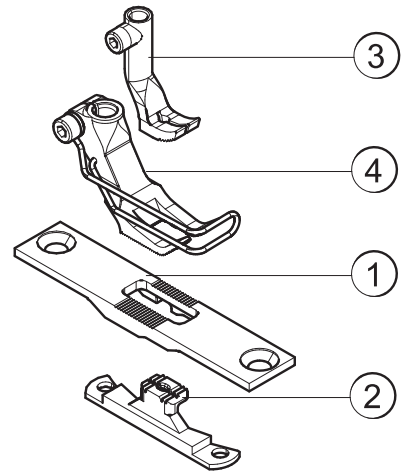

E3

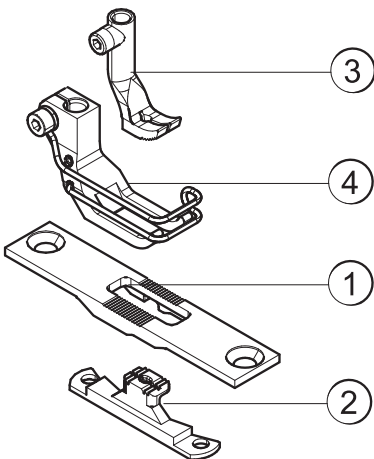

E4

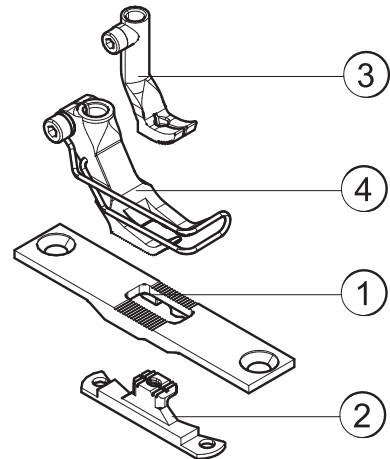

E5

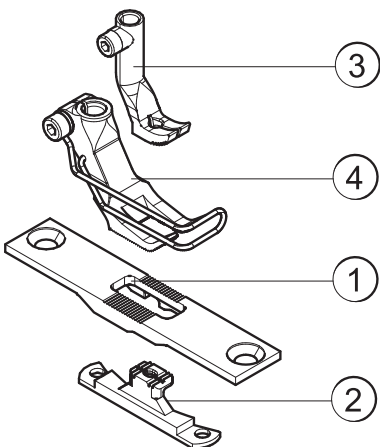

E6

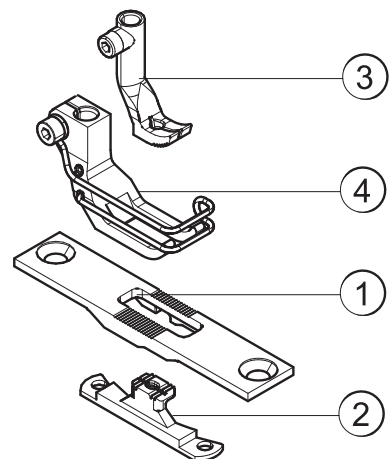



E7

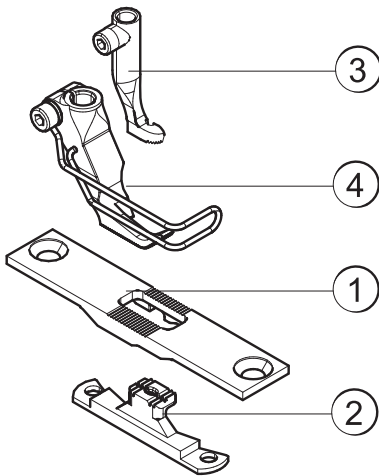

E8

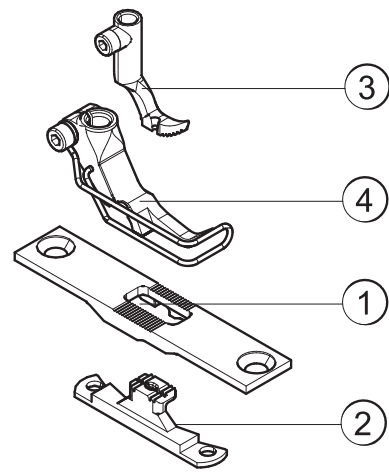

E11

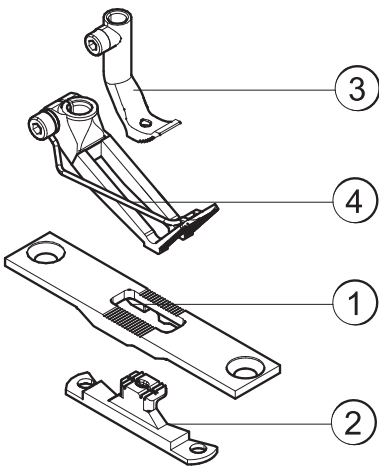

E12

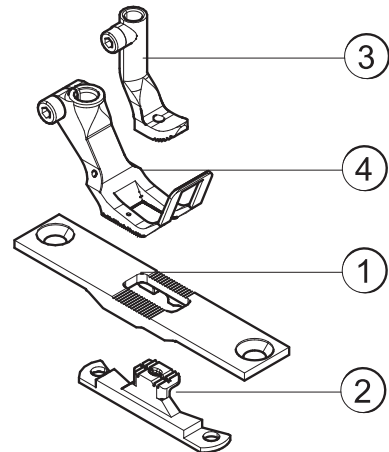

E14

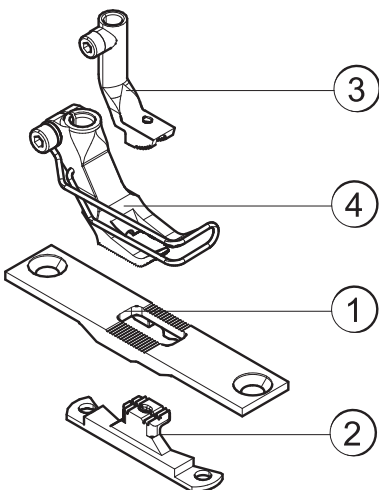

E15

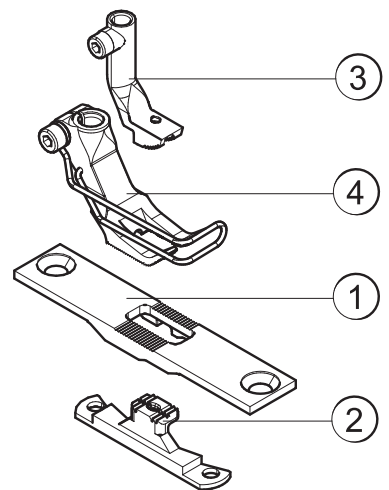



E16

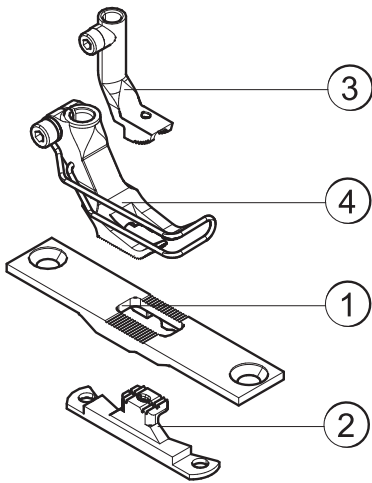

E17

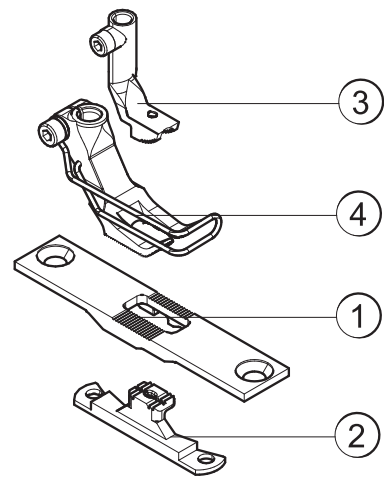

E18

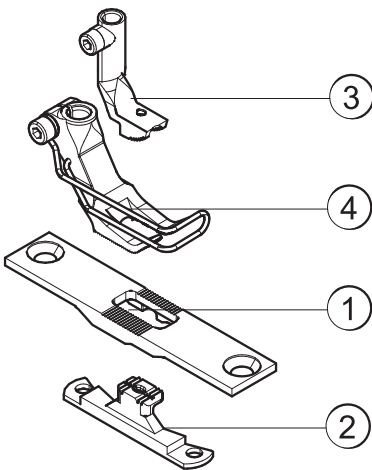

E25

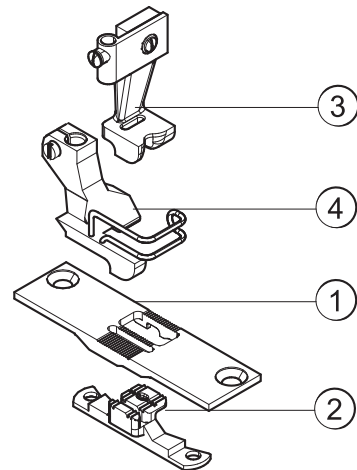

E26

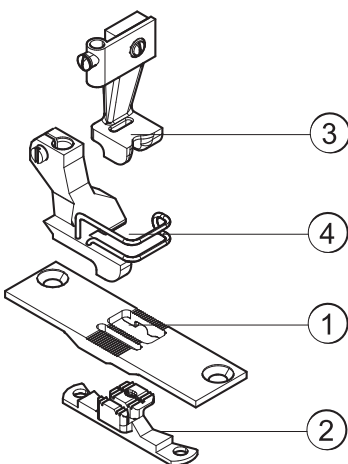

E31/3

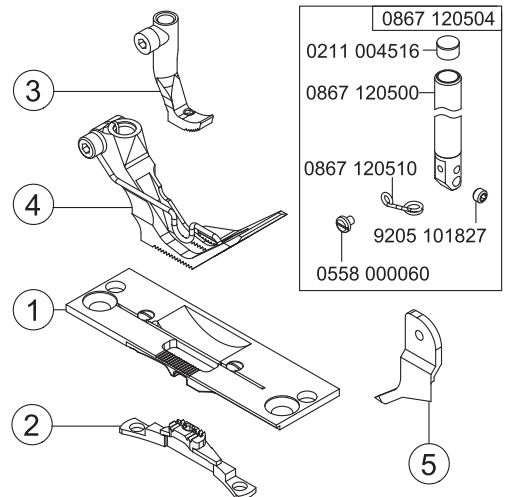



E31/5

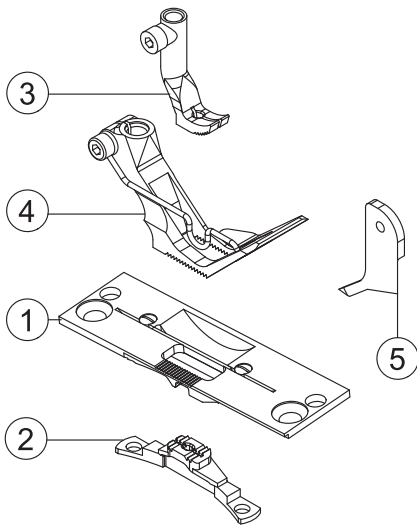

E31/8

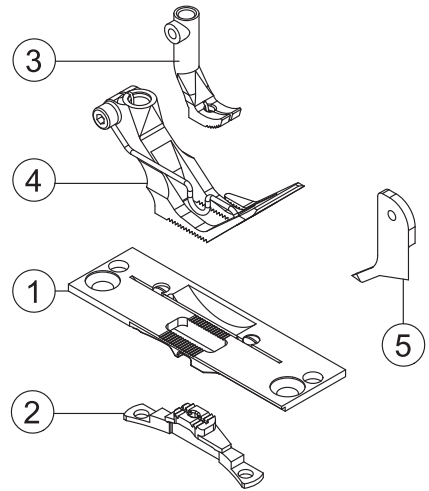

E36

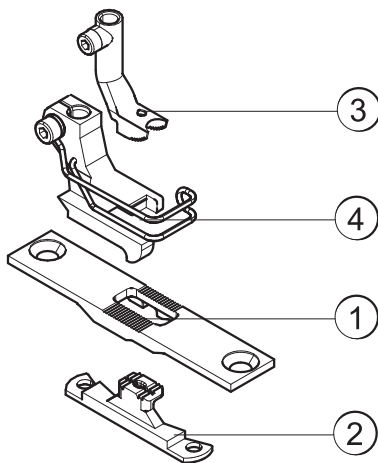

E38

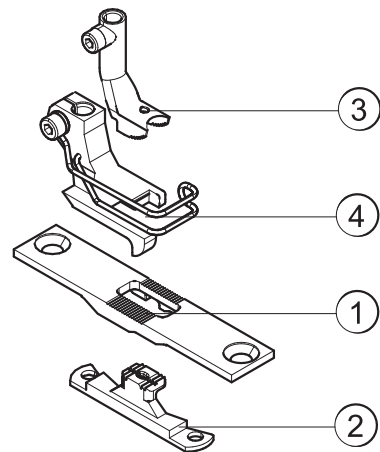

E41

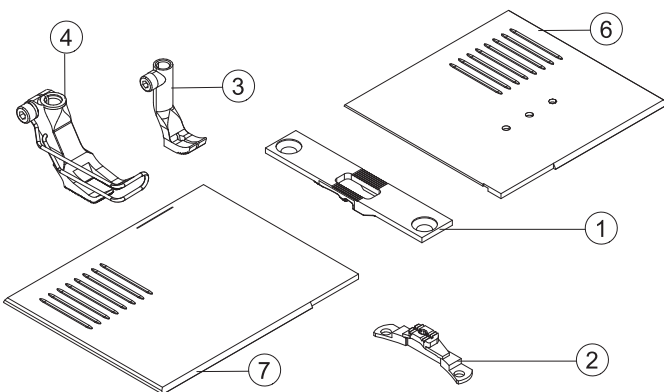

E42

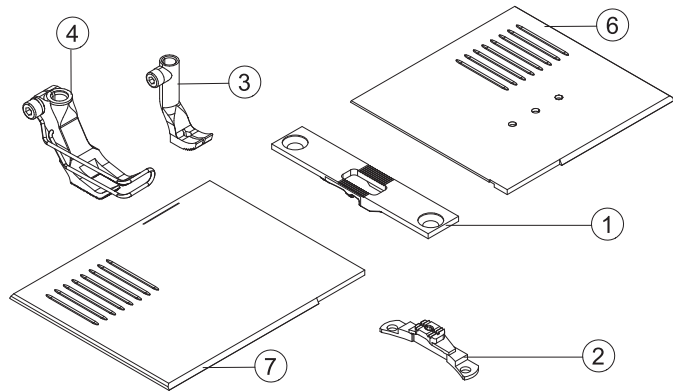



E46

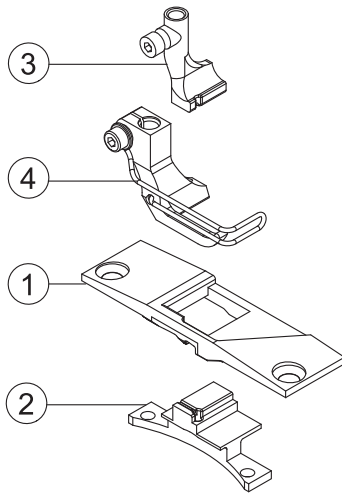

E49

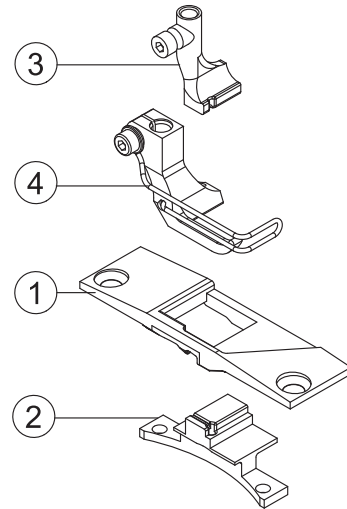

E101

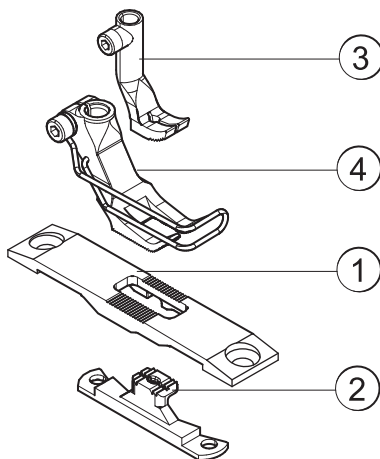

E102

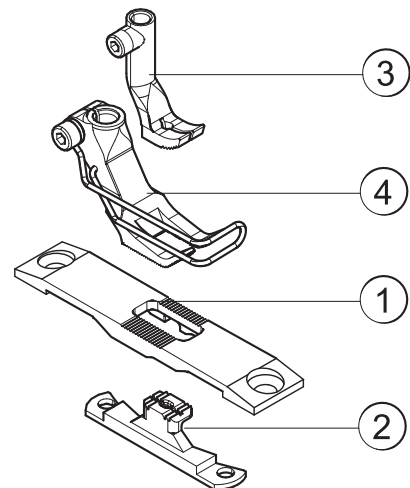



E21/4
E721/4

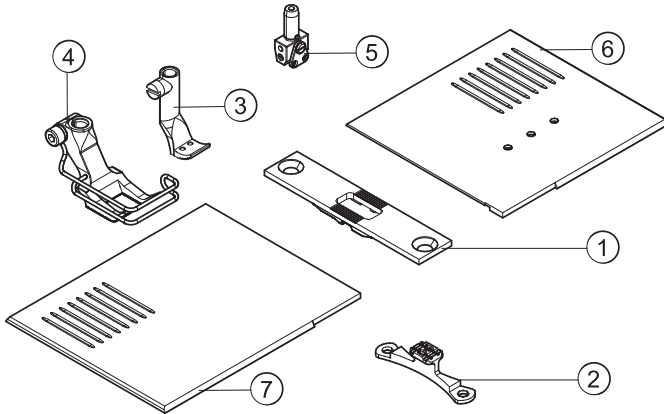

E21/5
E721/5

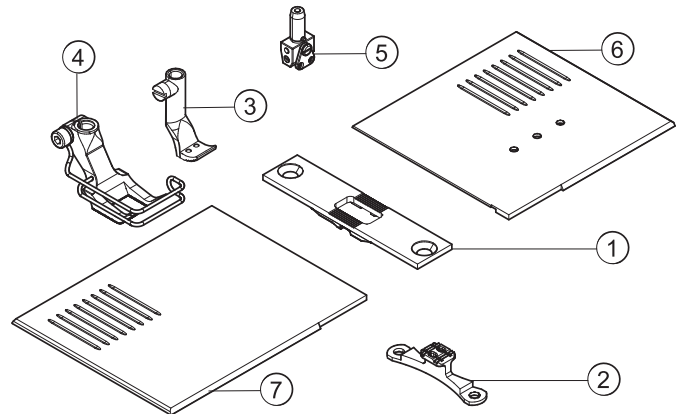

E21/6
E721/6

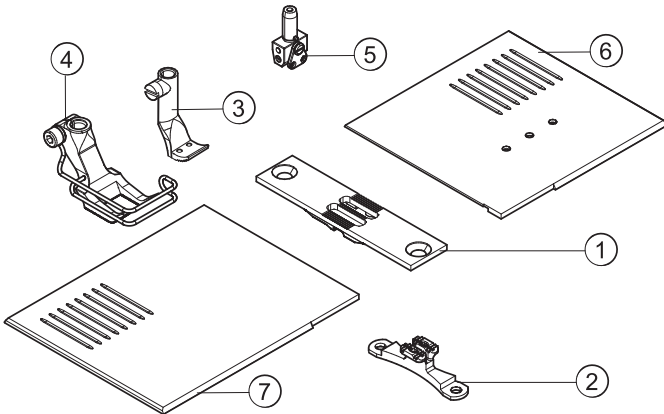

E21/8
E721/8

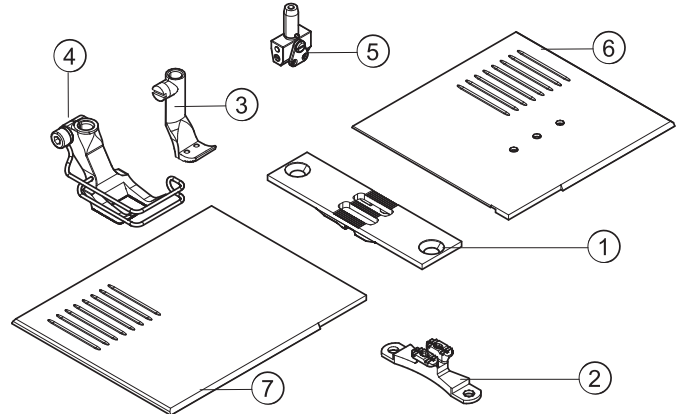

E21/10
E721/10

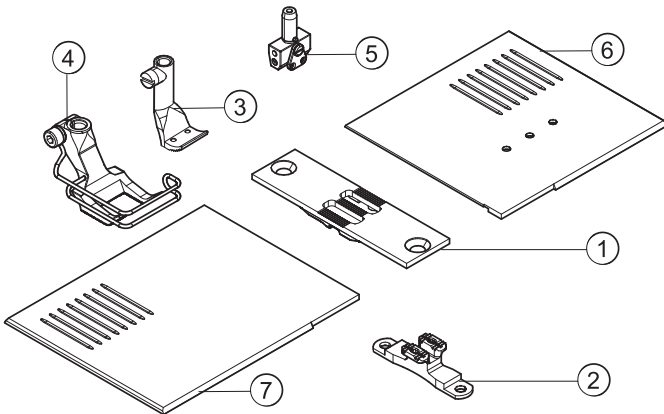

E21/12
E721/12

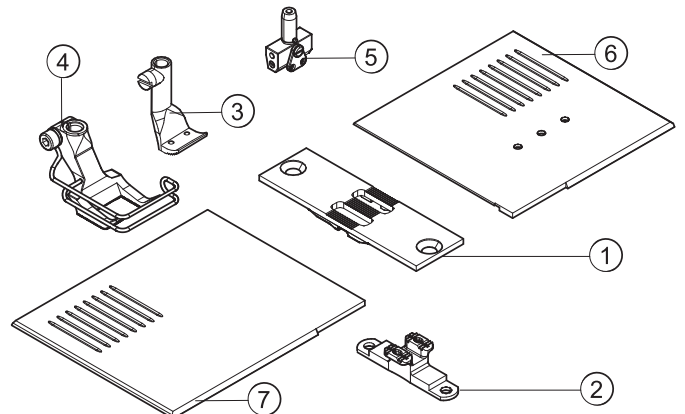



E21/14
E721/14

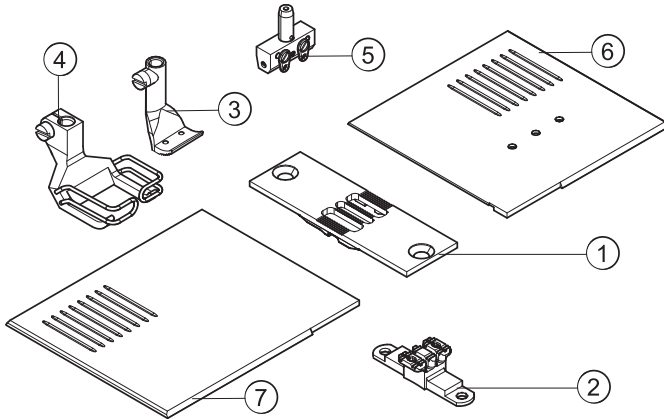

E21/16
E721/16

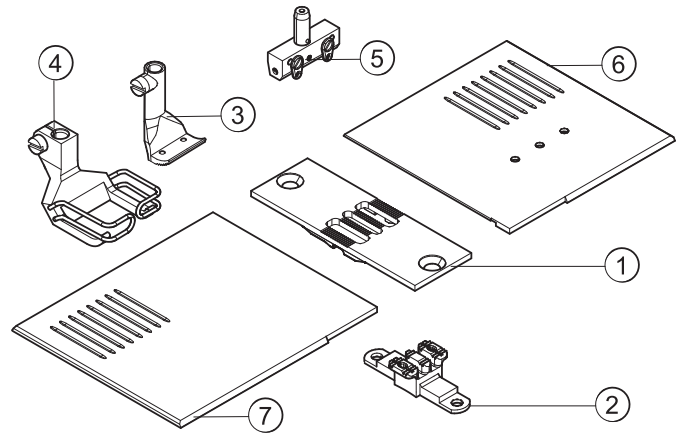

E21/18
E721/18

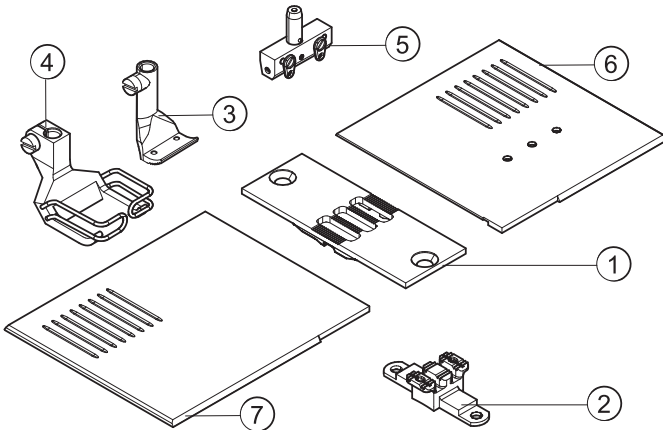

E21/20
E721/20

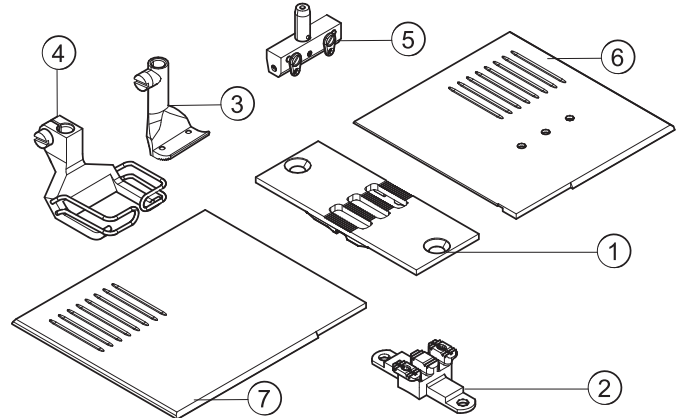

E21/22
E721/22

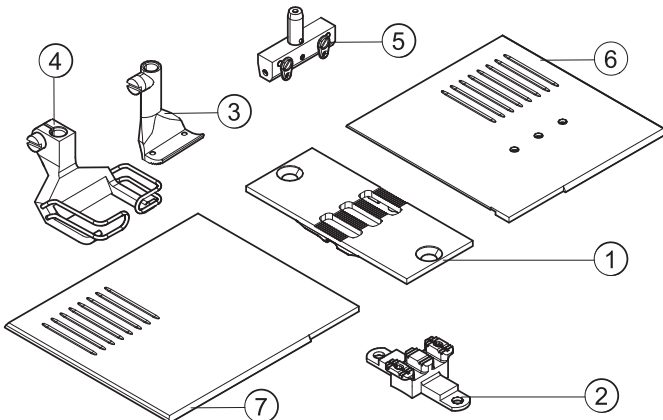

E21/50
E721/50

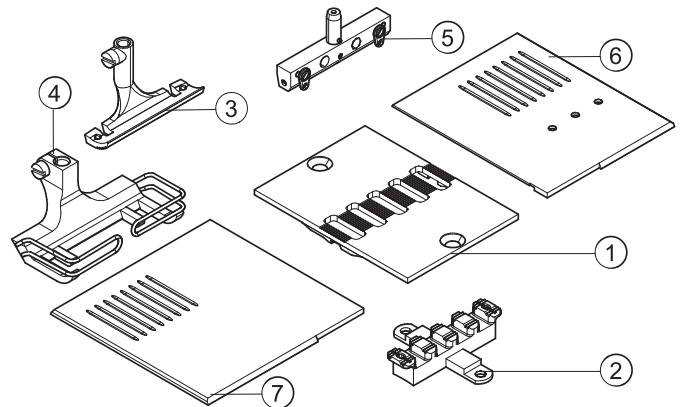



E22/6/9
E722/6/9

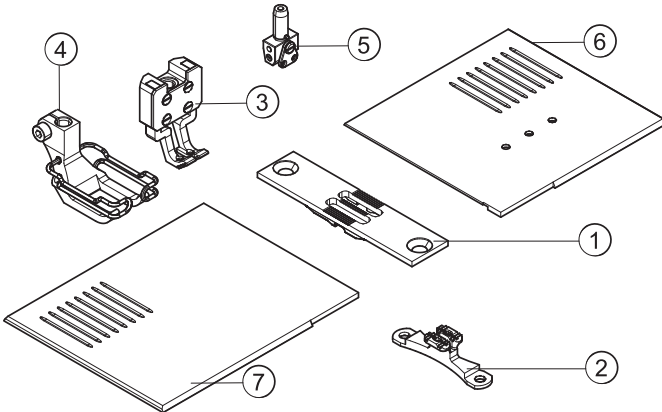

E22/8/6
E722/8/6

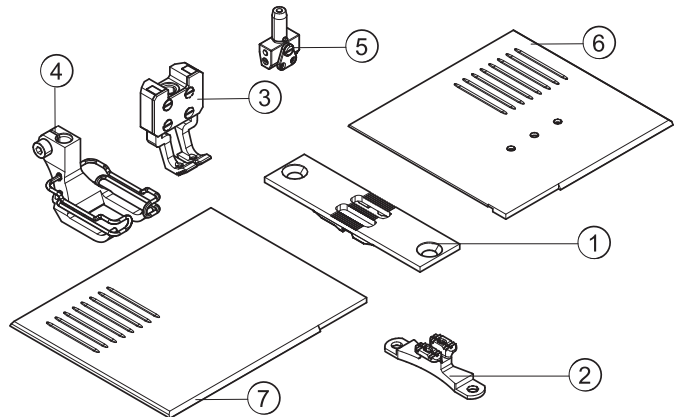

E22/8/9
E722/8/9

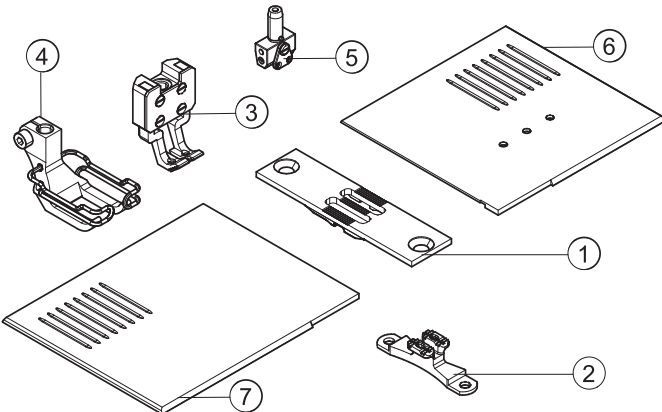

E22/10/6
E722/10/6

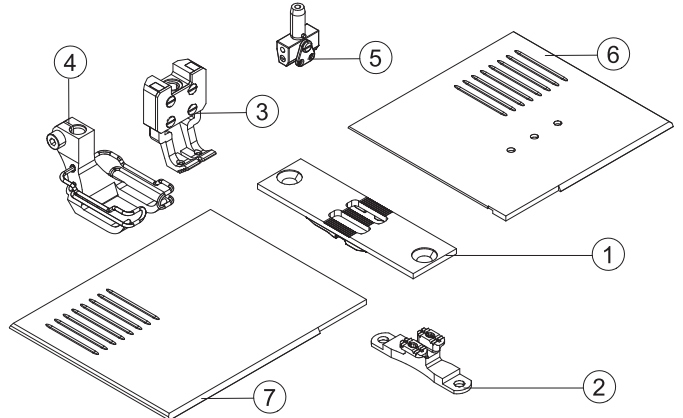

E22/10/9
E722/10/9

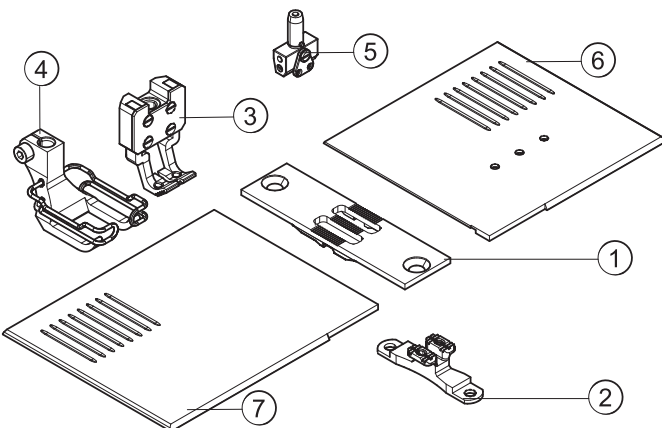

E22/10/12
E722/10/12

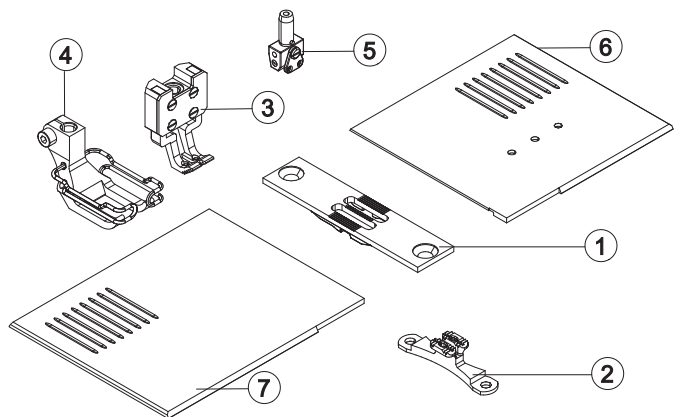



E22/12/9
E722/12/9

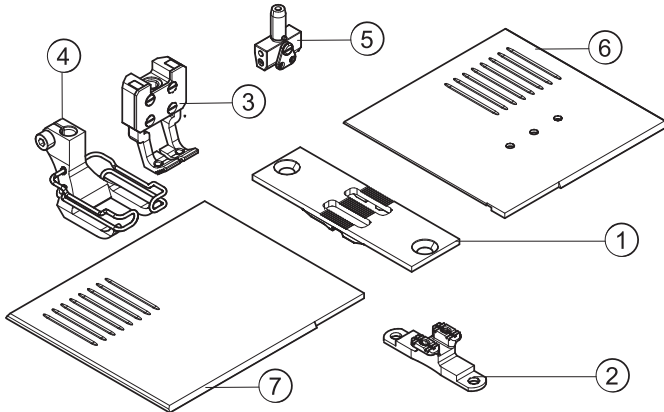

E22/12/12
E722/12/12

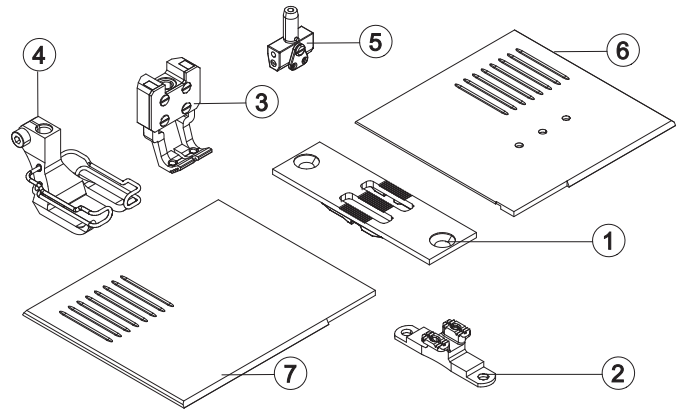

E22/14/12
E722/14/12

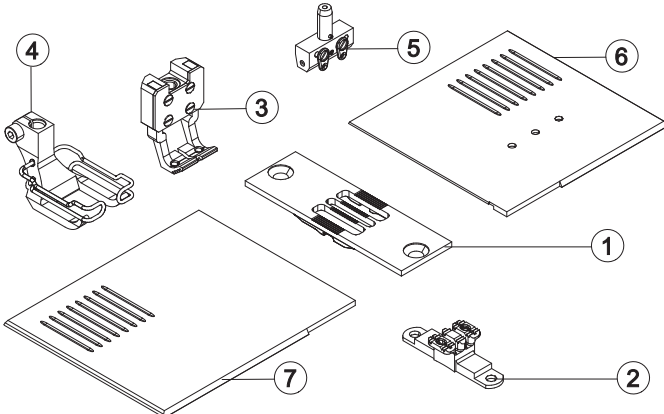

E23/10
E723/10

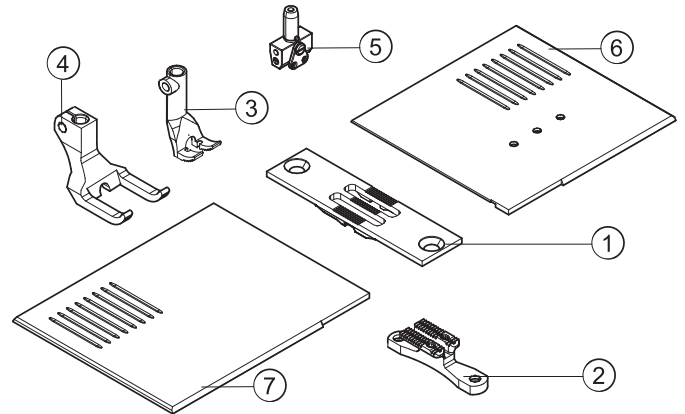

E23/12
E723/12

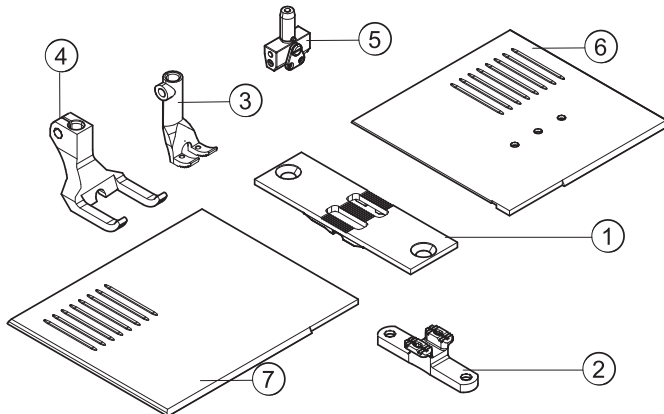



E24/6/9
E724/6/9

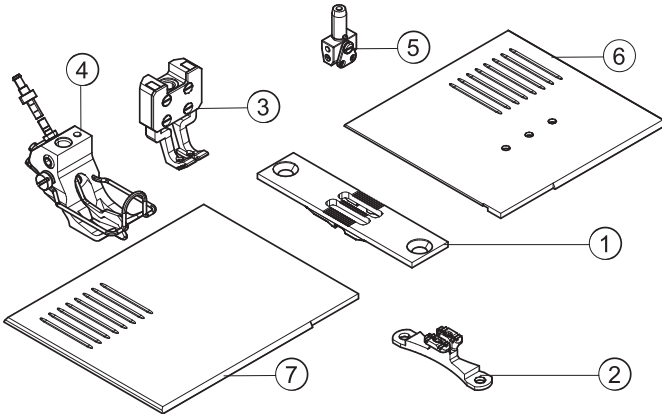

10 siehe Blatt 1/see page 1

E24/8/9
E724/8/9

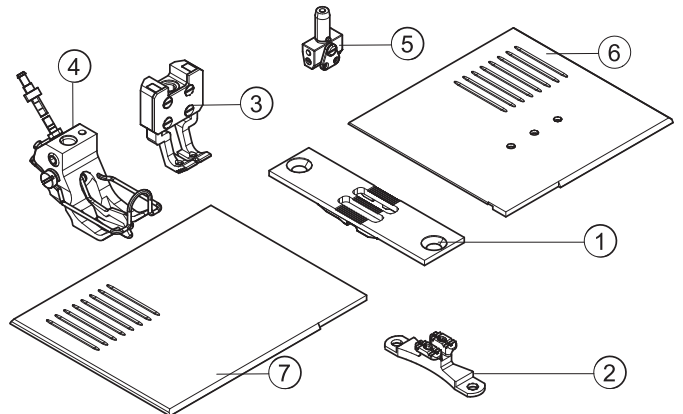

10 siehe Blatt 1/see page 1

E24/10/9
E724/10/9

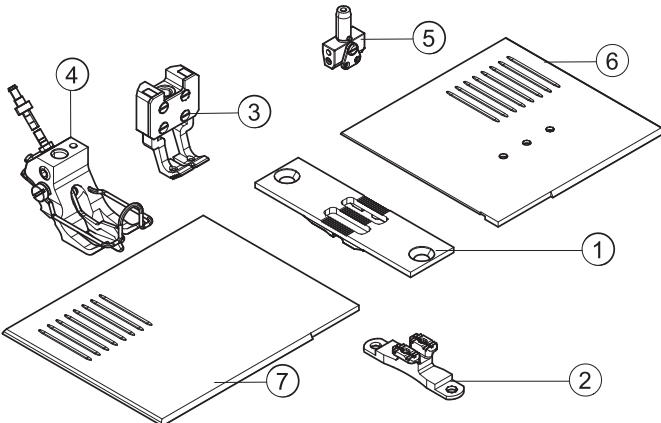

10 siehe Blatt 1/see page 1

E24/12/9
E724/12/9

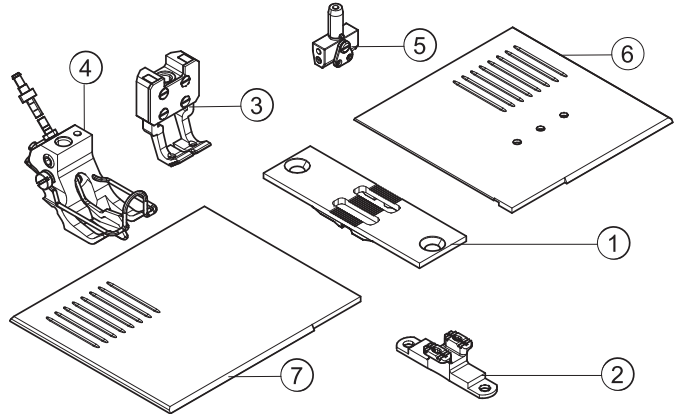

10 siehe Blatt 1/see page 1

E24/8/12
E724/8/12

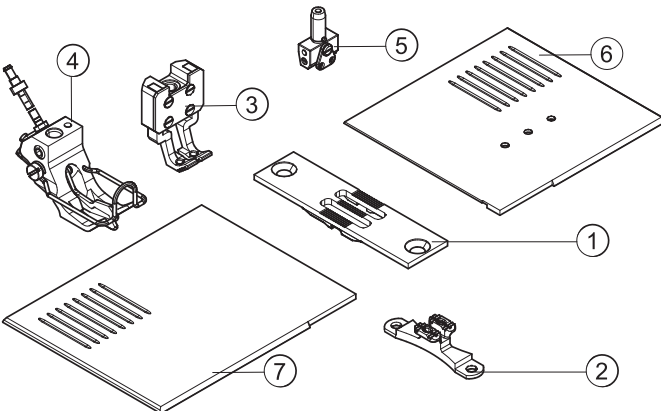

10 siehe Blatt 1/see page 1

E24/10/12
E724/10/12

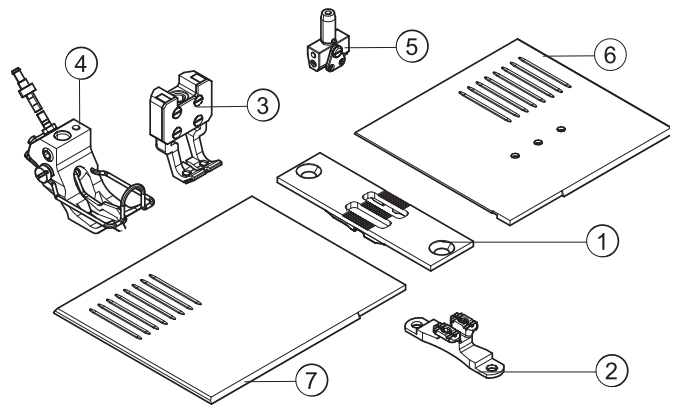

10 siehe Blatt 1/see page 1



E24/12/12
E724/12/12

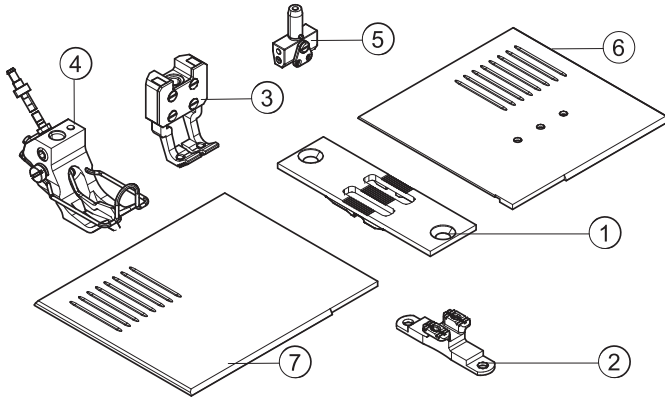

10 siehe Blatt 1/see page 1

E24/14/12
E724/14/12

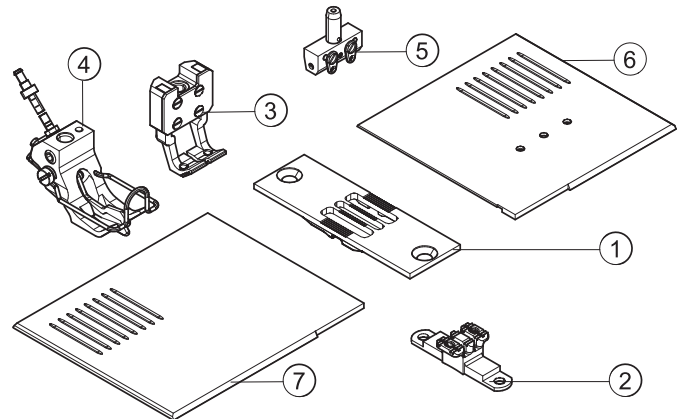

10 siehe Blatt 1/see page 1

E51/8/9
E751/8/9

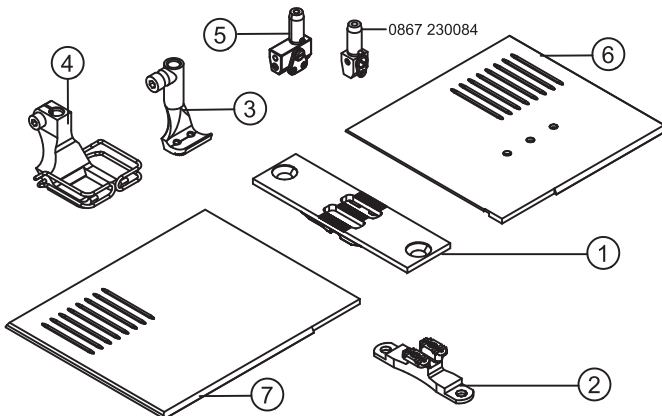

E51/10/9
E751/10/9

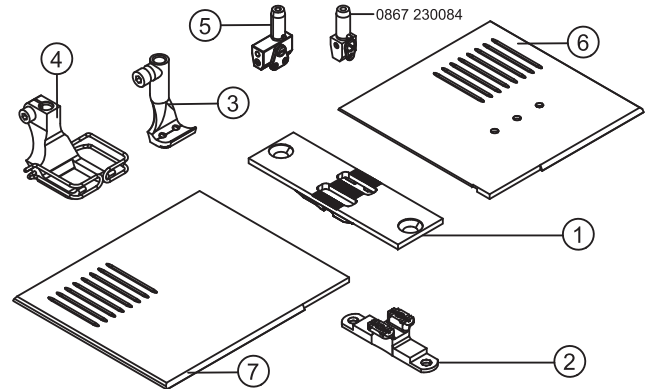

E51/12/9
E751/12/9

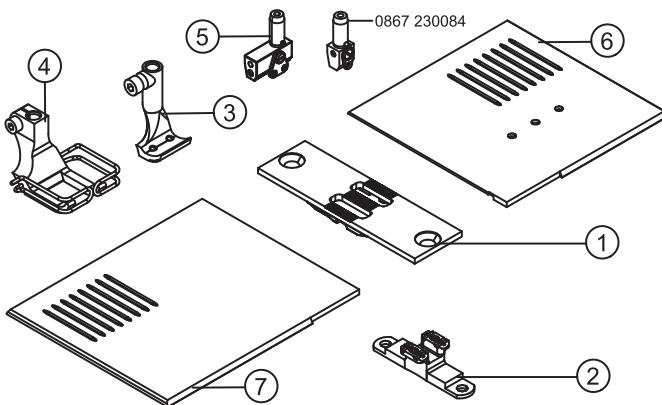

E51/14/9
E751/14/9

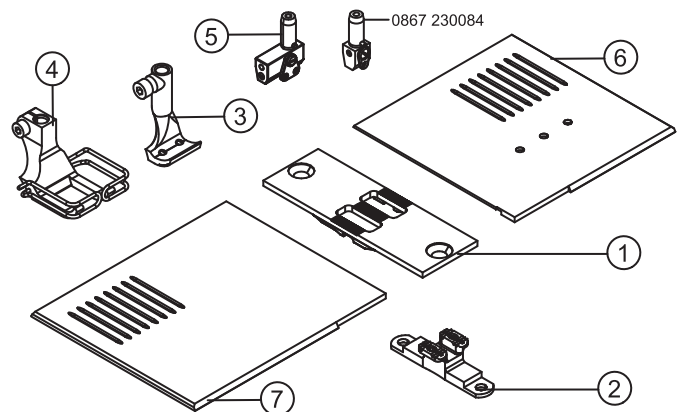



E121/6/6

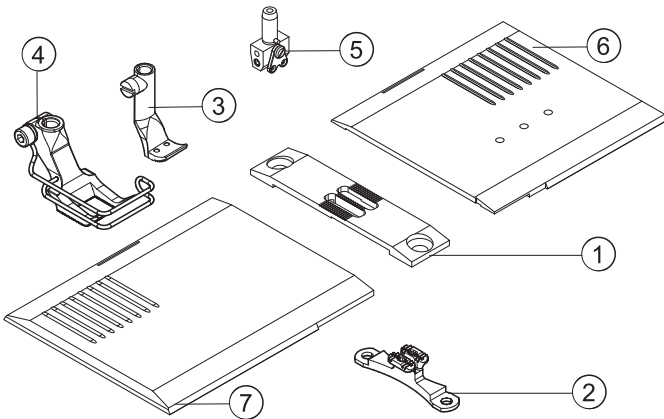

E121/8/6

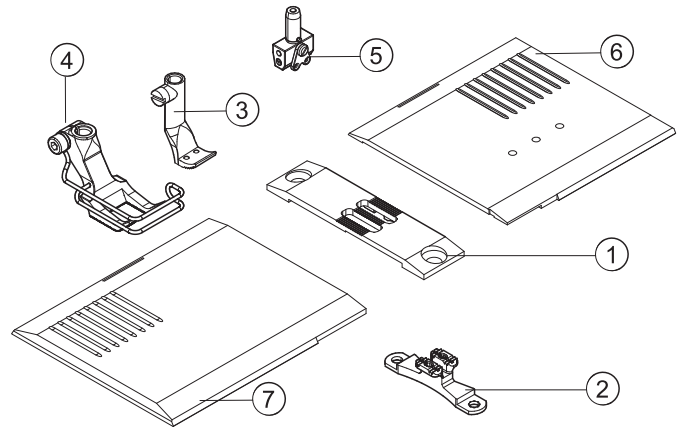

E121/10/6

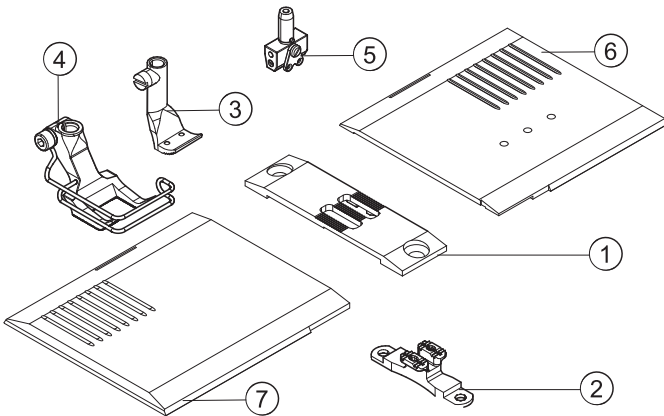

E121/12/6

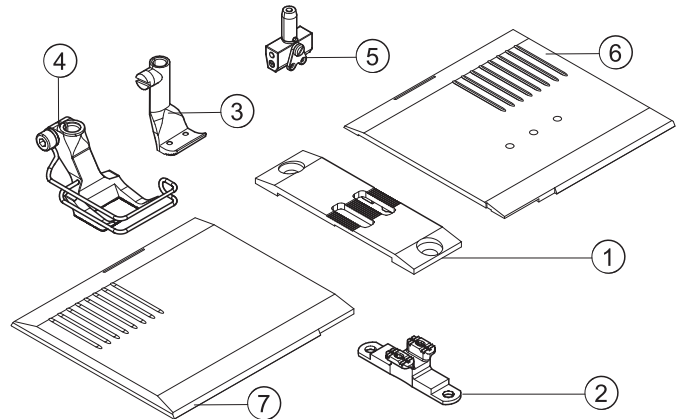

E122/6/9

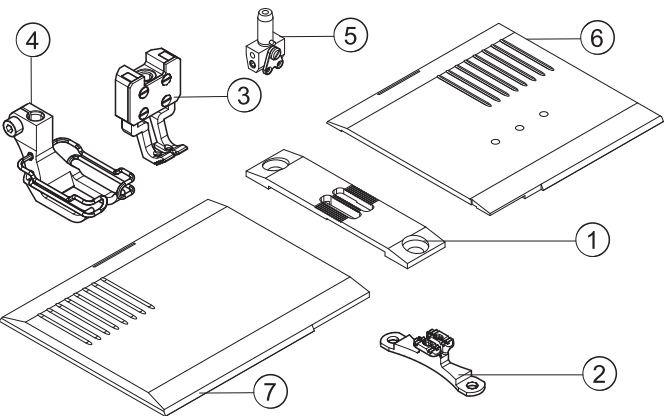

E122/8/9

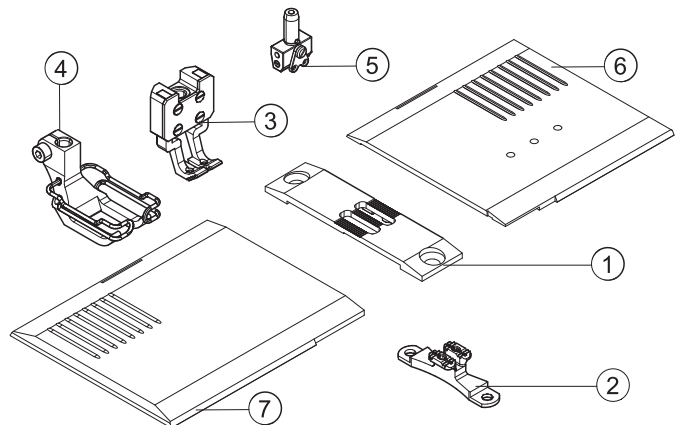



E122/10/9

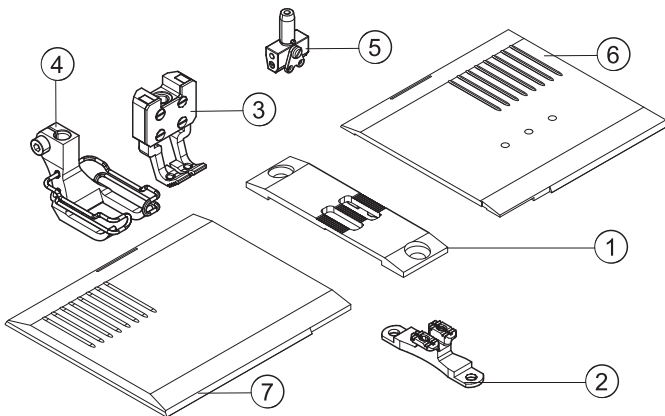

E122/12/9

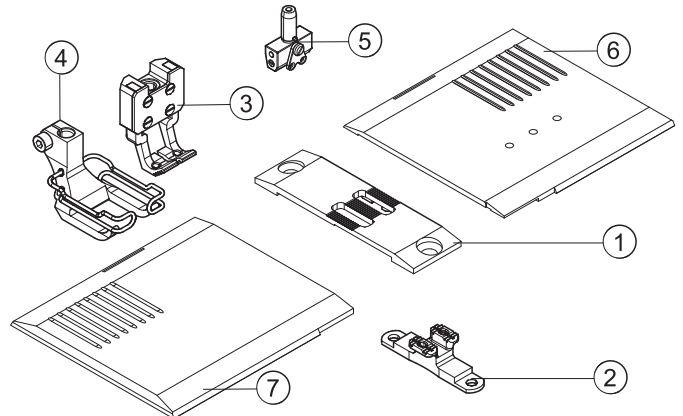

E421/5/6

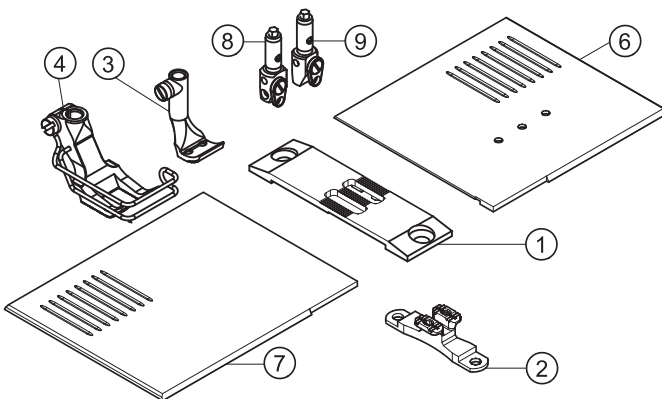

E424/6/9

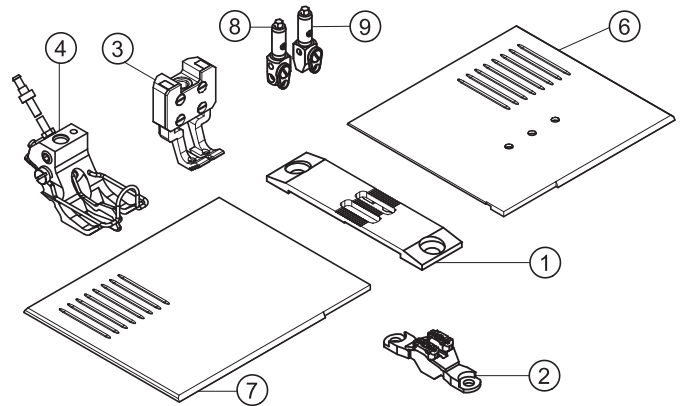

10 siehe Blatt 1/see page 1

E424/8/9

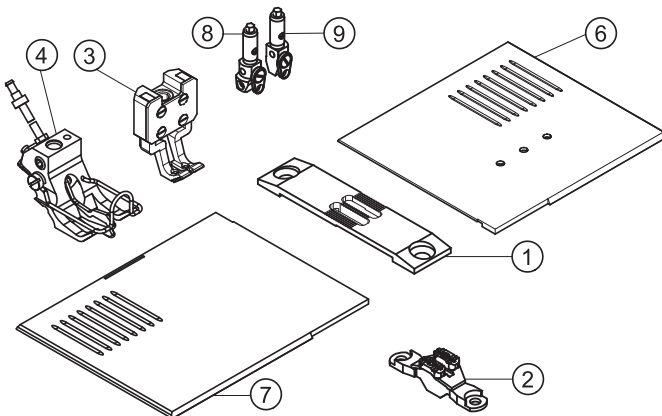

10 siehe Blatt 1/see page 1



E-Nr. E-No. Abb.-Nr. Fig.No.	Für Unterklasse / For Subclass Verwendungszweck / Use	Material No. / Material Nr.	Stichplatte Throat plate		Transporteur Feed dog				Presserfuß Presser foot	Transp. Fuß Feeding foot	Nadelhalter/ Needle holder	Nadelsystem / -dicke / Needle system / -size	
			①						②	④			③
E1	-190020; -190040; -190122; -190142; -190322; -190342; -190020-70; -190040-70; -190122-70; -190142-70; -190322-70; -190342-70 Näheinrichtung, Nadelstärke Nm 110-140, Stichlänge max. 6 mm, für mittelschweres Nähgut. Sewing equipment, needle size Nm 110-140, stitch length max. 6 mm, for medium weight material.	0867 E00106	0867 200010			2,2 x 3,2	0867 210010		0367 220993			0467 220013	134-35/130
E2	-190020; -190040; -190122; -190142; -190322; -190342; -190020-70; -190040-70; -190122-70; -190142-70; -190322-70; -190342-70 Näheinrichtung, Nadelstärke Nm 110-140, Stichlänge max. 9 mm, für mittelschweres Nähgut. Sewing equipment, needle size Nm 110-140, stitch length max. 9 mm, for medium weight material.	0867 E00209	0867 200020			2,2 x 3,2	0867 210010		0467 220043			0467 220013	134-35/130
E3	-190020; -190040; -190122; -190142; -190322; -190342; -190020-70; -190040-70; -190122-70; -190142-70; -190322-70; -190342-70 Näheinrichtung, Nadelstärke Nm 110-140, Stichlänge max. 12 mm, für mittelschweres Nähgut. Sewing equipment, needle size Nm 110-140, stitch length max. 12 mm, for medium weight material.	0867 E00312	0867 200030			2,2 x 3,2	0867 210010		0768 220013			0467 220013	134-35/130
E4	-190020; -190040; -190122; -190142; -190322; -190342; -190020-70; -190040-70; -190122-70; -190142-70; -190322-70; -190342-70 Näheinrichtung, Nadelstärke Nm 140-170, Stichlänge max. 6 mm, für mittelschweres Nähgut. Sewing equipment, needle size Nm 140-170, stitch length max. 6 mm, for medium weight material.	0867 E00406	0867 200010			3,0 x 3,7	0867 210020		0367 220993			0768 220113	134-35/160
E5	-190020; -190040; -190122; -190142; -190322; -190342; -190020-70; -190040-70; -190122-70; -190142-70; -190322-70; -190342-70 Näheinrichtung, Nadelstärke Nm 140-170, Stichlänge max. 9 mm, für mittelschweres Nähgut. Sewing equipment, needle size Nm 140-170, stitch length max. 9 mm, for medium weight material.	0867 E00509	0867 200020			3,0 x 3,7	0867 210020		0467 220043			0768 220113	134-35/160



E-Nr. E-No.	Für Unterklasse / For Subclass	Abb.-Nr. Fig.No.	Verwendungszweck / Use	Material No. / Material Nr.	Stichplatte Throat plate		Transporteur Feed dog				Presserfuß Presser foot		Transp. Fuß Feeding foot					
					①	②	③	④	⑤	⑥	⑦	⑧	⑨	⑩				
E6	-190020; -190040; -190122; -190142; -190322; -190342; -190020-70; -190040-70; -190122-70; -190142-70; -190322-70; -190342-70 Näheinrichtung, Nadelstärke Nm 140-170, Stichtlänge max. 12 mm, für mittelschweres Nähgut. Sewing equipment, needle size Nm 140-170, stitch length max. 12 mm, for medium weight material.			0867 E00612	0867 200030			3,0 x 3,7	0867 210020			0768 220013			0768 220113			134-35/160
E7	-190020; -190040; -190122; -190142; -190322; -190342; -190020-70; -190040-70; -190122-70; -190142-70; -190322-70; -190342-70 Näheinrichtung für kantennahe Näharbeiten, ab 1 mm rechts der Nadel, Nadelstärke Nm 110-140, Stichtlänge max. 6 mm, für mittelschweres Nähgut. Sewing equipment for stitching on edges, from 1 mm on the right from the needle, needle size Nm 110-140, stitch length max. 6 mm, for medium weight material.			0867 E00706	0867 200010			2,2 x 3,2	0867 210010			0367 220293			0067 220713			134-35/130
E8	-190020; -190040; -190122; -190142; -190322; -190342; -190020-70; -190040-70; -190122-70; -190142-70; -190322-70; -190342-70 Näheinrichtung für kantennahe Näharbeiten, ab 1 mm links der Nadel, Nadelstärke Nm 110-140, Stichtlänge max. 6 mm, für mittelschweres Nähgut. Sewing equipment for stitching on edges, from 1 mm on the left from the needle, needle size Nm 110-140, stitch length max. 6 mm, for medium weight material.			0867 E00806	0867 200010			2,2 x 3,2	0867 210010			0367 220303			0067 220703			134-35/130
E11	-190020; -190040; -190122; -190142; -190322; -190342; -190020-70; -190040-70; -190122-70; -190142-70; -190322-70; -190342-70 Näheinrichtung zum Überklettern starker Quernähte, Nadelstärke Nm 110-140, Stichtlänge max. 9 mm, für mittelschweres Nähgut. Sewing equipment for stitching of cross seams in thick material, needle size Nm 110-140, stitch length max. 9 mm, for medium weight material.			0867 E01109	0867 200020			2,2 x 3,2	0867 210010			0767 220013			0467 220483			134-35/130
E12	-190020; -190040; -190122; -190142; -190322; -190342; -190020-70; -190040-70; -190122-70; -190142-70; -190322-70; -190342-70 Näheinrichtung für wattiertes Nähgut, Nadelstärke Nm 110-140, Stichtlänge max. 6 mm, für mittelschweres Nähgut. Sewing equipment for padded material, needle size Nm 110-140, stitch length max. 6 mm, for medium weight material.			0867 E01206	0867 200010			2,2 x 3,2	0867 210010			0367 221543			0367 221553			134-35/130



E-Nr. E-No.	Für Unterklasse / For Subclass	Abb.-Nr. Fig.No.	Verwendungszweck / Use	Material No. / Material Nr.	Stichplatte Throat plate		Transporteur Feed dog		Presserfuß Presser foot	Transp. Fuß Feeding foot											
					①			②				④	③								
E14	-190020; -190040; -190122; -190142; -190322; -190342; -190020-70; -190040-70; -190122-70; -190142-70; -190322-70; -190342-70 Näheinrichtung für Kederarbeiten, Kedernut 4 mm, Nadelstärke Nm 110-140. Stichlänge max. 6 mm, für mittelschweres Nähgut. Sewing equipment for welt attaching operations, welt groove 4 mm, needle size Nm 110-140. Stich length max. 6 mm, for medium weight material.			0867 E01406	0867 200010			2,2 x 3,2	0867 210010			0367 220773				0167 220583					134-35/130
E15	-190020; -190040; -190122; -190142; -190322; -190342; -190020-70; -190040-70; -190122-70; -190142-70; -190322-70; -190342-70 Näheinrichtung für Kederarbeiten, Kedernut 5 mm, Nadelstärke Nm 110-140, Stichlänge max. 6 mm, für mittelschweres Nähgut. Sewing equipment for welt attaching operations, welt groove 5 mm, needle size Nm 110-140, stitch length max. 6 mm, for medium weight material.			0867 E01506	0867 200010			2,2 x 3,2	0867 210010			0367 220783				0167 220603					134-35/130
E16	-190020; -190040; -190122; -190142; -190322; -190342; -190020-70; -190040-70; -190122-70; -190142-70; -190322-70; -190342-70 Näheinrichtung für Kederarbeiten, Kedernut 6 mm, Nadelstärke Nm 110-140, Stichlänge max. 6 mm, für mittelschweres Nähgut. Sewing equipment for welt attaching operations, welt groove 6 mm, needle size Nm 110-140, stitch length max. 6 mm, for medium weight material.			0867 E01606	0867 200010			2,2 x 3,2	0867 210010			0367 220793				0167 220363					134-35/130
E17	-190020; -190040; -190122; -190142; -190322; -190342; -190020-70; -190040-70; -190122-70; -190142-70; -190322-70; -190342-70 Näheinrichtung für Kederarbeiten, Kedernut 7 mm, Nadelstärke Nm 110-140, Stichlänge max. 6 mm, für mittelschweres Nähgut. Sewing equipment for welt attaching operations, welt groove 7 mm, needle size Nm 110-140, stitch length max. 6 mm, for medium weight material.			0867 E01706	0867 200010			2,2 x 3,2	0867 210010			0367 220803				0167 220633					134-35/130
E18	-190020; -190040; -190122; -190142; -190322; -190342; -190020-70; -190040-70; -190122-70; -190142-70; -190322-70; -190342-70 Näheinrichtung für Kederarbeiten, Kedernut 8 mm, Nadelstärke Nm 110-140, Stichlänge max. 6 mm, für mittelschweres Nähgut. Sewing equipment for welt attaching operations, welt groove 8 mm, needle size Nm 110-140, stitch length max. 6 mm, for medium weight material.			0867 E01806	0867 200010			2,2 x 3,2	0867 210010			0367 220813				0167 220653					134-35/130



E-Nr. E-No.	Für Unterklasse / For Subclass	Abb.-Nr. Fig.No.	Verwendungszweck / Use	Material No. / Material Nr.	Stichplatte	Transporteur				Presserfuß	Transp. Fuß										
					Throat plate	Feed dog				Presser foot	Feeding foot										
					①				②	④	③										
					Stichplatte / Throat plate	Schieber, links / Slide, left	Schieber, rechts / Slide, right	Stichlochgröße / Stitch hole size mm	Sägeverzahn / Serrated mm	Säge-schrägverzahn / Serrated, oblique mm	Kreuzverzahn / Cross toothed mm	Dachverzahn / Roof-shaped mm	Drückerfuß / Presser foot	Unverzahn / Non toothed	Hüpfersfuß, kreuzverz. / Skipping f., cross toothed	Ausgleichfuß / Compensating foot	Kreuzverzahn / Cross toothed mm	Unverzahn / Non toothed	Messer/Knife	Nadelstange / Needle bar	Nadelsystem / -dicke / Needle system / -size
E25	-190020; -190040; -190122; -190142; -190322; -190342; -190020-70; -190040-70; -190122-70; -190142-70; -190322-70; -190342-70		Näheinrichtung zum Vor- oder Einnähen von Keder, Kedernut 5 mm, Nadelstärke Nm 110-140, Stichlänge max. 6 mm, für mittelschweres Nähgut. Sewing equipment for stitching and welt attaching operations, welt groove 5 mm, needle size Nm 110-140, stitch length max. 6 mm, for medium weight material.	0867 E02506	0867 200040			2,2 x 3,2	0867 210040			0367 220653					0067 220924				134-35/130
E26	-190020; -190040; -190122; -190142; -190322; -190342; -190020-70; -190040-70; -190122-70; -190142-70; -190322-70; -190342-70		Näheinrichtung zum Vor- oder Einnähen von Keder, Kedernut 6 mm, Nadelstärke Nm 110-140, Stichlänge max. 6 mm, für mittelschweres Nähgut Sewing equipment for stitching and welt attaching operations, welt groove 6 mm, needle size Nm 110-140, stitch length max. 6 mm, for medium weight material.	0867 E02606	0867 200040			2,2 x 3,2	0867 210040			0367 220663					0067 220934				134-35/130
E31/3	-393342		Näheinrichtung zum Nähen und Beschneiden, Schneidabstand 3 mm, Nadelstärke Nm 110-140, Stichlänge max. 6 mm, für mittelschweres Nähgut. Sewing equipment for stitching and trimming, trimming distance 3 mm, needle size Nm 110-140, stitch length max. 6 mm, for medium weight material.	0867 E03106 3	0867 201104			2,2 x 3,2	0867 211100			0867 220194					0867 220173	0867 330270	0867 120504		134-35/120
E31/5	-393342		Näheinrichtung zum Nähen und Beschneiden, Schneidabstand 5 mm, Nadelstärke Nm 110-140, Stichlänge max. 6 mm, für mittelschweres Nähgut. Sewing equipment for stitching and trimming, trimming distance 5 mm, needle size Nm 110-140, stitch length max. 6 mm, for medium weight material.	0867 E03106 5	0867 201114			2,2 x 3,2	0867 211110			0867 220204					0867 220183	0867 330280			134-35/120
E 31/8	-393342		Näheinrichtung zum Nähen und Beschneiden, Schneidabstand 8 mm, Nadelstärke Nm 110-140, Stichlänge max. 6 mm, für mittelschweres Nähgut. Sewing equipment for stitching and trimming, trimming distance 8 mm, needle size Nm 110-140, stitch length max. 6 mm, for medium weight material.	0867 E03106 8	0867 201124			2,2 x 3,2	0867 211110			0867 220214					0467 220013	0867 330280			134-35/120



E-Nr. E-No.	Für Unterklasse / For Subclass	Abb.-Nr. Fig.No.	Verwendungszweck / Use	Material No. / Material Nr.	Stichplatte Throat plate			Transporteur Feed dog	Presserfuß Presser foot	Transp. Fuß Feeding foot		
					①	⑦	⑥					
E36	-190020; -190040; -190122; -190142; -190322; -190342; -190020-70; -190040-70; -190122-70; -190142-70; -190322-70; -190342-70		Näheinrichtung zum Auf- oder Einnähen von Kordel, Kordelnut 6 mm, Nadelstärke Nm 110-140, Stichlänge max. 6 mm, für mittelschweres Nähgut. Sewing equipment for stitching and cord attaching operations, cord groove 6 mm, needle size Nm 110-140, stitch length max. 6 mm, for medium weight material.	0867 E03606	0867 200010		2,2 x 3,2	0867 210010	0367 220363	0067 220863		134-35/130
E38	-190020; -190040; -190122; -190142; -190322; -190342; -190020-70; -190040-70; -190122-70; -190142-70; -190322-70; -190342-70		Näheinrichtung zum Auf- oder Einnähen von Kordel, Kordelnut 8 mm, Nadelstärke Nm 110-140, Stichlänge max. 6 mm, für mittelschweres Nähgut. Sewing equipment for stitching and cord attaching operations, cord groove 8 mm, needle size Nm 110-140, stitch length max. 6 mm, for medium weight material.	0867 E03806	0867 200010		2,2 x 3,2	0867 210010	0367 220373	0367 220383		134-35/130
E41 nur Versand/ only as shipment	-392040; -392342		Näheinrichtung, Linksgreifer, Nadelstärke Nm 110-140, Stichlänge max. 6 mm, für mittelschweres Nähgut. Sewing equipment, left hook, needle size Nm 110-140, stitch length max. 6 mm, for medium weight material.	0867 E04106	0867 200170	0867 140450	0867 140040	2,2 x 3,2	0867 210160	0367 220993	0467 220013	134-35/130
E42 nur Versand/ only as shipment	-392040; -392342		Näheinrichtung, Linksgreifer, Nadelstärke Nm 110-140, Stichlänge max. 9 mm, für mittelschweres Nähgut. Sewing equipmen, left hook, needle size Nm 110-140, stitch length max. 9 mm, for medium weight material.	0867 E04209	0867 200160	0867 140450	0867 140040	2,2 x 3,2	0867 210160	0467 220043	0467 220013	134-35/130



E-Nr. E-No.	Für Unterklasse / For Subclass	Abb.-Nr. Fig.No.	Verwendungszweck / Use	Material No. / Material Nr.	Stichplatte Throat plate		Transporteur Feed dog	Presserfuß Presser foot	Transp. Fuß Feeding foot	
					①	②				
E46	-392040; -392342 Näheinrichtung zum Einfassen, Nadelstärke Nm 110-140, Stichlänge max. 6 mm, für mittelschweres Nähgut. Sewing equipment for facing, needle size Nm 110-140, stitch length max. 6 mm, for medium weight material.			0867 E04606 0867 200140			Ø 2,5 0867 210150	0867 220103	0867 220123	134-35/130
E49	-392040; -392342 Näheinrichtung zum Einfassen, Nadelstärke Nm 110-140, Stichlänge max. 9 mm, für mittelschweres Nähgut. Sewing equipment for facing, needle size Nm 110-140, stitch length max. 9 mm, for medium weight material.			0867 E04909 0867 200150			Ø 2,5 0867 210150	0867 220103	0867 220123	134-35/130
E101	-190125; -190145; -190425; -190445 Näheinrichtung, Nadelstärke Nm 110-140, Stichlänge max. 6 mm, für mittelschweres Nähgut; mit Kurzfadenabschneider. Sewing equipment, needle size Nm 110-140, stitch length max. 6 mm, for medium weight material; with short thread trimmer			0867 E10106 0867 200050		2,2 x 3,2 0867 210050		0367 220993	0467 220013	134-35/130
E102	-190125; -190145; -190425; -190445 Näheinrichtung, Nadelstärke Nm 110-140, Stichlänge max. 9 mm, für mittelschweres Nähgut; mit Kurzfadenabschneider. Sewing equipment, needle size Nm 110-140, stitch length max. 9 mm, for medium weight material; with short thread trimmer			0867 E10209 0867 200060		2,2 x 3,2 0867 210050		0467 220043	0467 220013	134-35/130



E-Nr. E-No.	Für Unterklasse / For Subclass	Abb.-Nr. Fig.No.	Verwendungszweck / Use	Material No. / Material Nr.	Stichplatte Throat plate			Transporteur Feed dog				Presserfuß Presser foot		Transp. Fuß Feeding foot						
					① Stichplatte / Throat plate	⑦ Schieber, links / Slide, left	⑥ Schieber, rechts / Slide, right	Stichlochgröße / Stich hole size mm	Sägeverzahnung / Serrated mm	Säge-schrägverzahnung / Serrated, oblique mm	Kreuzverzahnung / Cross toothed mm	Dachverzahnung / Roof-shaped mm	Drückerfuß / Presser foot	Unverzahnung / Non toothed	Hüpfersfuß, kreuzverz. / Skipping f., cross toothed	Ausgleichfuß / Compensating foot	Kreuzverzahnung / Cross toothed mm	Unverzahnung / Non toothed	⑤ Nadelabstand / Needle distance	Nadelhalter / Needle holder
E21/4	-290020; -290040; -290122; -290142; -290322; -290342 Näheinrichtung, Nadelabstand 4 mm, Nadelstärke Nm 110-140, Stichlänge max. 6 mm, für mittelschweres Nähgut. Sewing equipment, needle gauge 4 mm, needle size Nm 110-140, stitch length max. 6 mm, for medium weight material.			0867 E02106 4	0867 200200	0867 140010	0867 140040	2,2 x 3,2	0867 210200				0367 222473				0067 222323	4	0867 230114	134-35/130
E21/5	-290020; -290040; -290122; -290142; -290322; -290342 Näheinrichtung, Nadelabstand 5 mm, Nadelstärke Nm 110-140. Stichlänge max. 6 mm, für mittelschweres Nähgut. Sewing equipment, needle gauge 5 mm, needle size Nm 110-140. Stich length max. 6 mm, for medium weight material			0867 E02106 5	0867 200210	0867 140010	0867 140040	2,2 x 3,2	0867 210210				0367 222243				0067 222333	5	0867 230124	134-35/130
E21/6	-290020; -290040; -290122; -290142; -290322; -290342 Näheinrichtung, Nadelabstand 6 mm, Nadelstärke Nm 110-140, Stichlänge max. 6 mm, für mittelschweres Nähgut. Sewing equipment, needle gauge 6 mm, needle size Nm 110-140, stitch length max. 6 mm, for medium weight material.			0867 E02106 6	0867 200220	0867 140010	0867 140040	2,2 x 3,2	0867 210220				0367 222093				0067 222343	6	0867 230134	134-35/130
E21/8	-290020; -290040; -290122; -290142; -290322; -290342 Näheinrichtung, Nadelabstand 8 mm, Nadelstärke Nm 110-140, Stichlänge max. 6 mm, für mittelschweres Nähgut. Sewing equipment, needle gauge 8 mm, needle size Nm 110-140, stitch length max. 6 mm, for medium weight material.			0867 E02106 8	0867 200230	0867 140050	0867 140060	2,2 x 3,2	0867 210230				0367 222103				0067 222353	8	0867 230144	134-35/130
E21/10	-290020; -290040; -290122; -290142; -290322; -290342 Näheinrichtung, Nadelabstand 10 mm, Nadelstärke Nm 110-140, Stichlänge max. 6 mm, für mittelschweres Nähgut. Sewing equipment, needle gauge 10 mm, needle size Nm 110-140, stitch length max. 6 mm, for medium weight material.			0867 E02106 10	0867 200240	0867 140050	0867 140060	2,2 x 3,2	0867 210240				0367 222013				0067 222363	10	0867 230154	134-35/130



E-Nr. E-No.	Für Unterklasse / For Subclass	Abb.-Nr. Fig.No.	Verwendungszweck / Use	Material No. / Material Nr.	Stichplatte Throat plate			Transporteur Feed dog				Presserfuß Presser foot		Transp. Fuß Feeding foot					
					① Stichplatte / Throat plate	⑦ Schieber, links / Slide, left	⑥ Schieber, rechts / Slide, right	Stichlochgröße / Stich hole size mm	Sägeverzahnung / Serrated mm	Säge-schrägverzahnung / Serrated, oblique mm	Kreuzverzahnung / Cross toothed mm	Dachverzahnung / Roof-shaped mm	Drückerfuß / Presser foot	Unverzahnung / Non toothed	Hüpfersfuß, kreuzverz. / Skipping f., cross toothed	Ausgleichfuß / Compensating foot	Kreuzverzahnung / Cross toothed mm	Unverzahnung / Non toothed	Nadelabstand / Needle distance
E21/12	-290020; -290040; -290122; -290142; -290322; -290342 Näheinrichtung, Nadelabstand 12 mm, Nadelstärke Nm 110-140, Stichlänge max. 6 mm, für mittelschweres Nähgut. Sewing equipment, needle gauge 12 mm, needle size Nm 110-140, stitch length max. 6 mm, for medium weight material.			0867 E02106 12	0867 200250	0867 140070	0867 140080	2,2 x 3,2	0867 210250				0367 222313			0067 222393	12	0867 230164	134-35/130
E21/14	-290020; -290040; -290122; -290142; -290322; -290342 Näheinrichtung, Nadelabstand 14 mm, Nadelstärke Nm 110-140, Stichlänge max. 6 mm, für mittelschweres Nähgut. Sewing equipment, needle gauge 14 mm, needle size Nm 110-140, stitch length max. 6 mm, for medium weight material.			0867 E02106 14	0867 200260	0867 140070	0867 140080	2,2 x 3,2	0867 210260				0367 222323			0067 222413	14	0867 230174	134-35/130
E21/16	-290020; -290040; -290122; -290142; -290322; -290342 Näheinrichtung, Nadelabstand 16 mm, Nadelstärke Nm 110-140, Stichlänge max. 6 mm, für mittelschweres Nähgut Sewing equipment, needle gauge 16 mm, needle size Nm 110-140, stitch length max. 6 mm, for medium weight material.			0867 E02106 16	0867 200270	0867 140090	0867 140100	2,2 x 3,2	0867 210270				0367 222333			0067 222423	16	0867 230184	134-35/130
E21/18	-290020; -290040; -290122; -290142; -290322; -290342 Näheinrichtung, Nadelabstand 18 mm, Nadelstärke Nm 110-140, Stichlänge max. 6 mm, für mittelschweres Nähgut. Sewing equipment, needle gauge 18 mm, needle size Nm 110-140, stitch length max. 6 mm, for medium weight material.			0867 E02106 18	0867 200280	0867 140090	0867 140100	2,2 x 3,2	0867 210280				0367 222533			0067 222433	18	0867 230194	134-35/130
E21/20	-290020; -290040; -290122; -290142; -290322; -290342 Näheinrichtung, Nadelabstand 20 mm, Nadelstärke Nm 110-140, Stichlänge max. 6 mm, für mittelschweres Nähgut. Sewing equipment, needle gauge 20 mm, needle size Nm 110-140, stitch length max. 6 mm, for medium weight material.			0867 E02106 20	0867 200290	0867 140110	0867 140120	2,2 x 3,2	0867 210290				0367 222543			0067 222443	20	0867 230204	134-35/130



E-Nr. E-No.	Für Unterklasse / For Subclass	Abb.-Nr. Fig.No.	Verwendungszweck / Use	Material No. / Material Nr.	Stichplatte Throat plate		Transporteur Feed dog				Presserfuß Presser foot	Transp. Fuß Feeding foot						
					① Stichplatte / Throat plate	⑦ Schieber, links / Slide, left	⑥ Schieber, rechts / Slide, right	Stichlochgröße / Stich hole size mm	Sägeverzahnung / Serrated mm	Säge-schrägverzahnung / Serrated, oblique mm	Kreuzverzahnung / Cross toothed mm	Dachverzahnung / Roof-shaped mm	Drückerfuß / Presser foot	Unverzahnung / Non toothed	Hüpfenfuß, kreuzverz. / Skipping f., cross toothed	Ausgleichfuß / Compensating foot	Kreuzverzahnung / Cross toothed mm	Unverzahnung / Non toothed
E21/22	-290020; -290040; -290122; -290142; -290322; -290342 Näheinrichtung, Nadelabstand 22 mm, Nadelstärke Nm 110-140, Stichlänge max. 6 mm, für mittelschweres Nähgut. Sewing equipment, needle gauge 22 mm, needle size Nm 110-140, stitch length max. 6 mm, for medium weight material.			0867 E02106 22	0867 200300	0867 140110	0867 140120	2,2 x 3,2	0867 210300			0367 222413			0067 222773	22	0867 230214	134-35/130
E21/50	-290020; -290040; -290122; -290142; -290322; -290342 Näheinrichtung, Nadelabstand 50 mm, Nadelstärke Nm 110-140, Stichlänge max. 6 mm, für mittelschweres Nähgut. Sewing equipment, needle gauge 50 mm, needle size Nm 110-140, stitch length max. 6 mm, for medium weight material.			0867 E02106 50	0867 200310	0867 140130	0867 140140	2,2 x 3,2	0867 210310			0367 223293			0367 223283	50	0867 230304	134-35/130
E22/6/9	-290020; -290040; -290122; -290142; -290322; -290342 Näheinrichtung zum Aussteppen von Schließnähten, Nadelabstand 6 mm, Nadelstärke Nm 110-140, Stichlänge max. 9 mm, für mittelschweres Nähgut. Sewing equipment for topstitching of closing seams, needle gauge 6 mm, needle size Nm 110-140, stitch length max. 9 mm, for medium weight material.			0867 E02209 6	0867 200400	0867 140010	0867 140040	2,2 x 3,2	0867 210220			0768 222123			0768 222264	6	0867 230134	134-35/130
E22/8/6	-290020; -290040; -290122; -290142; -290322; -290342 Näheinrichtung zum Aussteppen von Schließnähten, Nadelabstand 8 mm, Nadelstärke Nm 110-140, Stichlänge max. 6 mm, für mittelschweres Nähgut. Sewing equipment for topstitching of closing seams, needle gauge 8 mm, needle size Nm 110-140, stitch length max. 6 mm, for medium weight material.			0867 E02206 8	0867 200230	0867 140050	0867 140060	2,2 x 3,2	0867 210230			0768 222133			0768 222274	8	0867 230144	134-35/130
E22/8/9	-290020; -290040; -290122; -290142; -290322; -290342 Näheinrichtung zum Aussteppen von Schließnähten, Nadelabstand 8 mm, Nadelstärke Nm 110-140, Stichlänge max. 9 mm, für mittelschweres Nähgut. Sewing equipment for topstitching of closing seams, needle gauge 8 mm, needle size Nm 110-140, stitch length max. 9 mm, for medium weight material.			0867 E02209 8	0867 200410	0867 140050	0867 140060	2,2 x 3,2	0867 210230			0768 222133			0768 222274	8	0867 230144	134-35/130



E-Nr. E-No. Abb.-Nr. Fig.No.	Für Unterklasse / For Subclass Verwendungszweck / Use	Material No. / Material Nr.	Stichplatte Throat plate			Transporteur Feed dog				Presserfuß Presser foot	Transp. Fuß Feeding foot					
			①	⑦	⑥				②	④	③					
E22/10/6	-290020; -290040; -290122; -290142; -290322; -290342 Näheinrichtung zum Aussteppen von Schließnähten, Nadelabstand 10 mm, Nadelstärke Nm 110-140, Stichlänge max. 6 mm, für mittelschweres Nähgut. Sewing equipment for topstitching of closing seams, needle gauge 10 mm, needle size Nm 110-140, stitch length max. 6 mm, for medium weight material.	0867 E02206 10	0867 200240	0867 140050	0867 140060	2,2 x 3,2	0867 210240			0768 222143		0768 222284		10	0867 230154	134-35/130
E22/10/9	-290020; -290040; -290122; -290142; -290322; -290342 Näheinrichtung zum Aussteppen von Schließnähten, Nadelabstand 10 mm, Nadelstärke Nm 140-180, Stichlänge max. 9 mm, für mittelschweres Nähgut. Sewing equipment for topstitching of closing seams, needle gauge 10 mm, needle size Nm 140-180, stitch length max. 9 mm, for medium weight material.	0867 E02209 10	0867 200420	0867 140050	0867 140060	2,8 x 3,7	0867 210450			0768 222143		0768 222404		10	0867 230154	134-35/160
E22/10/12	-290020; -290040; -290122; -290142; -290322; -290342 Näheinrichtung zum Aussteppen von Schließnähten, Nadelabstand 10 mm, Nadelstärke Nm 140-180, Stichlänge max. 12 mm, für mittelschweres Nähgut. Sewing equipment for topstitching of closing seams, needle gauge 10 mm, needle size Nm 140-180, stitch length max. 12 mm, for medium weight material.	0867 E02212 10	0867 200450	0867 140050	0867 140060	2,8 x 3,7	0867 210450			0768 222143		0768 222404		10	0867 230154	134-35/160
E22/12/9	-290020; -290040; -290122; -290142; -290322; -290342 Näheinrichtung zum Aussteppen von Schließnähten, Nadelabstand 12 mm, Nadelstärke Nm 140-180, Stichlänge max. 9 mm, für mittelschweres Nähgut. Sewing equipment for topstitching of closing seams, needle gauge 12 mm, needle size Nm 140-180, stitch length max. 9 mm, for medium weight material.	0867 E02209 12	0867 200430	0867 140070	0867 140080	2,8 x 3,7	0867 210460			0768 222153		0768 222434		12	0867 230164	134-35/160



E-Nr. E-No.	Für Unterklasse / For Subclass	Abb.-Nr. Fig.No.	Verwendungszweck / Use	Material No. / Material Nr.	Stichplatte Throat plate			Transporteur Feed dog				Presserfuß Presser foot	Transp. Fuß Feeding foot	⑤	Nadelhalter/ Needle holder	Nadelsystem/-dicke / Needle system/-size	
					①	⑦	⑥	②	③	④	③						
E22/12/12	-290020; -290040; -290122; -290142; -290322; -290342 Näheinrichtung zum Aussteppen von Schließnähten, Nadelabstand 12 mm, Nadelstärke Nm 140-180, Stichlänge max. 12 mm, für mittelschweres Nähgut. Sewing equipment for topstitching of closing seams, needle gauge 12 mm, needle size Nm 140-180, stitch length max. 12 mm, for medium weight material.			0867 E02212 12	0867 200460	0867 140070	0867 140080	2,8 x 3,7	0867 210460			0768 222153		0768 222434	12	0867 230164	134-35/160
E22/14/12	-290020; -290040; -290122; -290142; -290322; -290342 Näheinrichtung zum Aussteppen von Schließnähten, Nadelabstand 14 mm, Nadelstärke Nm 140-180, Stichlänge max. 12 mm, für mittelschweres Nähgut. Sewing equipment for topstitching of closing seams, needle gauge 14 mm, needle size Nm 140-180, stitch length max. 12 mm, for medium weight material.			0867 E02212 14	0867 200470	0867 140070	0867 140080	2,8 x 3,7	0867 210470			0867 222163		0768 222464	14	0867 230174	134-35/160
E23/10	-290020; -290040; -290122; -290142; -290322; -290342 Näheinrichtung zum Einnähen von Reißverschlüssen, Nadelabstand 10 mm, Nadelstärke Nm 110-140, Stichlänge max. 6 mm, für mittelschweres Nähgut. Sewing equipment for inserting zippers, needle gauge 10 mm, needle size Nm 110-140, stitch length max. 6 mm, for medium weight material.			0867 E02306 10	0867 200950	0867 140050	0867 140060	∅ 1,7	0867 210950			0367 222510		0067 224103	10	0867 230154	134-35/130
E23/12	-290020; -290040; -290122; -290142; -290322; -290342 Näheinrichtung zum Einnähen von Reißverschlüssen, Nadelabstand 12 mm, Nadelstärke Nm 110-140, Stichlänge max. 6 mm, für mittelschweres Nähgut. Sewing equipment for inserting zippers, needle gauge 12 mm, needle size Nm 110-140, stitch length max. 6 mm, for medium weight material.			0867 E02306 12	0867 200960	0867 140070	0867 140080	∅ 2	0867 210960			0367 222373		0067 223223	12	0867 230164	134-35/130



E-Nr. E-No.	Für Unterklasse / For Subclass	Abb.-Nr. Fig.No.	Verwendungszweck / Use	Material No. / Material Nr.	Stichplatte	Transporteur			Presserfuß	Transp. Fuß											
					Throat plate	Feed dog			Presser foot	Feeding foot											
					①	⑦	⑥		②	④	③										
					Stichplatte / Throat plate	Schieber, links / Slide, left	Schieber, rechts / Slide, right	Stichlochgröße / Stitch hole size mm	Sägezahn / Serrated mm	Säge-schrägverzahn / Serrated, oblique mm	Kreuzverzahn / Cross toothed mm	Dachverzahn / Roof-shaped mm	Drückerfuß / Presser foot	Unverzahn / Non toothed	Hüpfertfuß, kreuzverz. / Skipping f., cross toothed	Ausgleichfuß / Compensating foot	Kreuzverzahn / Cross toothed mm	Unverzahn / Non toothed	Nadelabstand / Needle distance	Nadelhalter / Needle holder	Nadelsystem / -dicke / Needle system / -size
E24/6/9	-290122; -290142; -290322; -290342 Näheinrichtung zum Aussteppen von Schließnähten, Nadelabstand 6 mm, Nadelstärke Nm 110-140, Stichtlänge max. 9 mm, für mittelschweres Nähgut. Sewing equipment for topstitching of closing seams, needle gauge 6 mm, needle size Nm 110-140, stitch length max. 9 mm, for medium weight material.			0867 E02409 6	0867 200400	0867 140010	0867 140040	2,2 x 3,2	0867 210220				0768 222664			0768 222264			6	0867 230134	134-35/130
E24/8/9	-290122; -290142; -290322; -290342 Näheinrichtung zum Aussteppen von Schließnähten, Nadelabstand 8 mm, Nadelstärke Nm 110-140, Stichtlänge max. 9 mm, für mittelschweres Nähgut. Sewing equipment for topstitching of closing seams, needle gauge 8 mm, needle size Nm 110-140, stitch length max. 9 mm, for medium weight material.			0867 E02409 8	0867 200410	0867 140050	0867 140060	2,2 x 3,2	0867 210230				0768 222674			0768 222274			8	0867 230144	134-35/130
E24/10/9	-290122; -290142; -290322; -290342 Näheinrichtung zum Aussteppen von Schließnähten, Nadelabstand 10 mm, Nadelstärke Nm 110-140, Stichtlänge max. 9 mm, für mittelschweres Nähgut. Sewing equipment for topstitching of closing seams, needle gauge 10 mm, needle size Nm 110-140, stitch length max. 9 mm, for medium weight material.			0867 E02409 10	0867 200420	0867 140050	0867 140060	2,2 x 3,2	0867 210240				0768 222684			0768 222284			10	0867 230154	134-35/130
E24/12/9	-290122; -290142; -290322; -290342 Näheinrichtung zum Aussteppen von Schließnähten, Nadelabstand 12 mm, Nadelstärke Nm 110-140, Stichtlänge max. 9 mm, für mittelschweres Nähgut. Sewing equipment for topstitching of closing seams, needle gauge 12 mm, needle size Nm 110-140, stitch length max. 9 mm, for medium weight material.			0867 E02409 12	0867 200430	0867 140070	0867 140080	2,2 x 3,2	0867 210250				0768 222694			0768 222294			12	0867 230164	134-35/130



E-Nr. E-No.	Für Unterklasse / For Subclass	Abb.-Nr. Fig.No.	Verwendungszweck / Use	Material No. / Material Nr.	Stichplatte Throat plate			Transporteur Feed dog				Presserfuß Presser foot		Transp. Fuß Feeding foot				
					①	⑦	⑥											
E24/8/12	-290122; -290142; -290322; -290342 Näheinrichtung zum Aussteppen von Schließnähten, Nadelabstand 8 mm, Nadelstärke Nm 140-180, Stichtlänge max. 12 mm, für mittelschweres Nähgut. Sewing equipment for topstitching of closing seams, needle gauge 8 mm, needle size Nm 140-180, stitch length max. 12 mm, for medium weight material.			0867 E02412 8	0867 200440	0867 140050	0867 140060	2,8 x 3,7	0867 210440			0867 220054		0768 222374		8	0867 230144	134-35/160
E24/10/12	-290122; -290142; -290322; -290342 Näheinrichtung zum Aussteppen von Schließnähten, Nadelabstand 10 mm, Nadelstärke Nm 140-180, Stichtlänge max. 12 mm, für mittelschweres Nähgut. Sewing equipment for topstitching of closing seams, needle gauge 10 mm, needle size Nm 140-180, stitch length max. 12 mm, for medium weight material.			0867 E02412 10	0867 200450	0867 140050	0867 140060	2,8 x 3,7	0867 210450			0867 220064		0768 222404		10	0867 230154	134-35/160
E24/12/12	-290122; -290142; -290322; -290342 Näheinrichtung zum Aussteppen von Schließnähten, Nadelabstand 12 mm, Nadelstärke Nm 140-180, Stichtlänge max. 12 mm, für mittelschweres Nähgut. Sewing equipment for topstitching of closing seams, needle gauge 12 mm, needle size Nm 140-180, stitch length max. 12 mm, for medium weight material.			0867 E02412 12	0867 200460	0867 140070	0867 140080	2,8 x 3,7	0867 210460			0867 220074		0768 222434		12	0867 230164	134-35/160
E24/14/12	-290122; -290142; -290322; -290342 Näheinrichtung zum Aussteppen von Schließnähten, Nadelabstand 14 mm, Nadelstärke Nm 140-180, Stichtlänge max. 12 mm, für mittelschweres Nähgut. Sewing equipment for topstitching of closing seams, needle gauge 14 mm, needle size Nm 140-180, stitch length max. 12 mm, for medium weight material.			0867 E02412 14	0867 200470	0867 140070	0867 140080	2,8 x 3,7	0867 210470			0867 220084		0768 222464		14	0867 230174	134-35/160



E-Nr. E-No.	Für Unterklasse / For Subclass	Abb.-Nr. Fig.No.	Verwendungszweck / Use	Material No. / Material Nr.	Stichplatte	Transporteur		Presserfuß	Transp. Fuß								
					Throat plate	Feed dog	Presser foot	Feeding foot									
					①	⑦	⑥		②	④	③		⑤				
E51/8/9	-290020; -290040; -290122; -290142; -290322; -290342		Näheinrichtung asymmetrisch für allgemeine Näharbeiten. Die rechte Nadel befindet sich auf der Mitte der Nadelstange, um die Maschine auch als Einnadelmaschine einsetzen zu können. Nadelabstand 8 mm, Nadelstärke Nm 110-140, Stichlänge max. 9 mm, für mittelschweres Nähgut. Sewing equipment asymmetric for general sewing operations. The right needle is located on the needle bar center so that the machine could be also used as a single needle one. Needle gauge 8 mm, needle size Nm 110-140, stitch length max. 9 mm, for medium weight material.	0867 E05109 8	0867 200500	0867 140090	0867 140020	2,2 x 3,2	0867 210500			0867 220033		0867 220043	8	0867 230014	134-35/130
E51/10/9	-290020; -290040; -290122; -290142; -290322; -290342		Näheinrichtung asymmetrisch für allgemeine Näharbeiten. Die rechte Nadel befindet sich auf der Mitte der Nadelstange, um die Maschine auch als Einnadelmaschine einsetzen zu können. Nadelabstand 10 mm, Nadelstärke Nm 110-140, Stichlänge max. 9 mm, für mittelschweres Nähgut. Sewing equipment asymmetric for general sewing operations. The right needle is located on the needle bar center so that the machine could be also used as a single needle one. Needle gauge 10 mm, needle size Nm 110-140, stitch length max. 9 mm, for medium weight material.	0867 E05109 10	0867 200510	0867 140110	0867 140020	2,2 x 3,2	0867 210510			0467 222123		0467 222113	10	0867 230024	134-35/130
E51/12/9	-290020; -290040; -290122; -290142; -290322; -290342		Näheinrichtung asymmetrisch für allgemeine Näharbeiten. Die rechte Nadel befindet sich auf der Mitte der Nadelstange, um die Maschine auch als Einnadelmaschine einsetzen zu können. Nadelabstand 12 mm, Nadelstärke Nm 110-140, Stichlänge max. 9 mm, für mittelschweres Nähgut. Sewing equipment asymmetric for general sewing operations. The right needle is located on the needle bar center so that the machine could be also used as a single needle one. Needle gauge 12 mm, needle size Nm 110-140, stitch length max. 9 mm, for medium weight material.	0867 E05109 12	0867 200520	0867 140170	0867 140020	2,2 x 3,2	0867 210520			0467 222183		0467 222173	12	0867 230034	134-35/130



E-Nr. E-No.	Für Unterklasse / For Subclass	Abb.-Nr. Fig.No.	Verwendungszweck / Use	Material No. / Material Nr.	Stichplatte Throat plate			Transporteur Feed dog			Presserfuß Presser foot	Transp. Fuß Feeding foot						
					① Stichplatte / Throat plate	⑦ Schieber, links / Slide, left	⑥ Schieber, rechts / Slide, right	Stichlochgröße / Stich hole size mm	Sägeverzahnung / Serrated mm	Säge-schrägverzahnung / Serrated, oblique mm	Kreuzverzahnung / Cross toothed mm	Dachverzahnung / Roof-shaped mm	② Drückerfuß / Presser foot	④ Unverzahnung / Non toothed	Hüpfersfuß, kreuzverz. / Skipping f., cross toothed	③ Ausgleichfuß / Compensating foot	⑤ Kreuzverzahnung / Cross toothed mm	Unverzahnung / Non toothed
E51/14/9	-290020; -290040; -290122; -290142; -290322; -290342		Näheinrichtung asymmetrisch für allgemeine Näharbeiten. Die rechte Nadel befindet sich auf der Mitte der Nadelstange, um die Maschine auch als Einnadelmaschine einsetzen zu können. Nadelabstand 14 mm, Nadelstärke Nm 110-140, Stichlänge max. 9 mm, für mittelschweres Nähgut. Sewing equipment asymmetric for general sewing operations. The right needle is located on the needle bar center so that the machine could be also used as a single needle one. Needle gauge 14 mm, needle size Nm 110-140, stitch length max. 9 mm, for medium weight material.	0867 E05109 14	0867 200530	0867 140190	0867 140020	2,2 x 3,2	0867 210530			0467 222143			0467 222133	14	0867 230044	134-35/130
E121/6/6	-290445		Näheinrichtung, Nadelabstand 6 mm, Nadelstärke Nm 110-140, Stichlänge max. 6 mm, für mittelschweres Nähgut; mit Kurzfadenabschneider. Sewing equipment, needle gauge 6 mm, needle size Nm 110-140, stitch length max. 6 mm, for medium weight material; with short thread trimmer	0867 E12106 6	0867 200620	0867 140153	0867 140303	2,2 x 3,2	0867 210620			0367 222093			0067 222343	6	0867 230134	134-35/130
E121/8/6	-290445		Näheinrichtung, Nadelabstand 8 mm, Nadelstärke Nm 110-140, Stichlänge max. 6 mm, für mittelschweres Nähgut; mit Kurzfadenabschneider. Sewing equipment, needle gauge 8 mm, needle size Nm 110-140, stitch length max. 6 mm, for medium weight material; with short thread trimmer	0867 E12106 8	0867 200630	0867 140313	0867 140323	2,2 x 3,2	0867 210630			0367 222103			0067 222353	8	0867 230144	134-35/130
E121/10/6	-290445		Näheinrichtung, Nadelabstand 10 mm, Nadelstärke Nm 110-140, Stichlänge max. 6 mm, für mittelschweres Nähgut; mit Kurzfadenabschneider. Sewing equipment, needle gauge 10 mm, needle size Nm 110-140, stitch length max. 6 mm, for medium weight material; with short thread trimmer	0867 E12106 10	0867 200640	0867 140313	0867 140323	2,2 x 3,2	0867 210640			0367 222013			0067 222383	10	0867 230154	134-35/130



E-Nr. E-No.	Für Unterklasse / For Subclass	Abb.-Nr. Fig.No.	Verwendungszweck / Use	Material No. / Material Nr.	Stichplatte Throat plate			Transporteur Feed dog			Presserfuß Presser foot	Transp. Fuß Feeding foot	⑤	⑤		
					①	⑦	⑥	②	④	③						
E121/12/6	-290445 Näheinrichtung, Nadelabstand 12 mm, Nadelstärke Nm 110-140, Stichtlänge max. 6 mm, für mittelschweres Nähgut; mit Kurzfadenabschneider. Sewing equipment, needle gauge 12 mm, needle size Nm 110-140, stitch length max. 6 mm, for medium weight material; with short thread trimmer			0867 E12106 12	0867 200650	0867 140333	0867 140343	2,2 x 3,2	0867 210650		0367 222313		0067 222393	12	0867 230164	134-35/130
E122/6/9	-290445 Näheinrichtung zum Aussteppen von Schließnähten, Nadelabstand 6 mm, Nadelstärke Nm 110-140, Stichtlänge max. 9 mm, für mittelschweres Nähgut; mit Kurzfadenabschneider. Sewing equipment for topstitching of closing seams, needle gauge 6 mm, needle size Nm 110-140, stitch length max. 9 mm, for medium weight material; with short thread trimmer			0867 E12209 6	0867 200800	0867 140153	0867 140303	2,2 x 3,2	0867 210620		0768 222123			6	0867 230134	134-35/130
E122/8/9	-290445 Näheinrichtung zum Aussteppen von Schließnähten, Nadelabstand 8 mm, Nadelstärke Nm 110-140, Stichtlänge max. 9 mm, für mittelschweres Nähgut; mit Kurzfadenabschneider. Sewing equipment for topstitching of closing seams, needle gauge 8 mm, needle size Nm 110-140, stitch length max. 9 mm, for medium weight material; with short thread trimmer			0867 E12209 8	0867 200810	0867 140313	0867 140323	2,2 x 3,2	0867 210630		0768 222133			8	0867 230144	134-35/130
E122/10/9	-290445 Näheinrichtung zum Aussteppen von Schließnähten, Nadelabstand 10 mm, Nadelstärke Nm 140-180, Stichtlänge max. 9 mm, für mittelschweres Nähgut; mit Kurzfadenabschneider. Sewing equipment for topstitching of closing seams, needle gauge 10 mm, needle size Nm 140-180, stitch length max. 9 mm, for medium weight material; with short thread trimmer			0867 E12209 10	0867 200820	0867 140313	0867 140323	2,2 x 3,2	0867 210640		0768 222143			10	0367 230154	134-35/160
E122/12/9	-290445 Näheinrichtung zum Aussteppen von Schließnähten, Nadelabstand 12 mm, Nadelstärke Nm 140-180, Stichtlänge max. 9 mm, für mittelschweres Nähgut; mit Kurzfadenabschneider. Sewing equipment for topstitching of closing seams, needle gauge 12 mm, needle size Nm 140-180, stitch length max. 9 mm, for medium weight material; with short thread trimmer			0867 E12209 12	0867 200830	0867 140333	0867 140343	2,2 x 3,2	0867 210650		0768 222153			12	0867 230164	134-35/160



E-Nr. E-No.	Für Unterklasse / For Subclass	Abb.-Nr. Fig.No.	Verwendungszweck / Use	Material No. / Material Nr.	Stichplatte Throat plate			Transporteur Feed dog	Presserfuß Presser foot	Transp. Fuß Feeding foot					
					①	⑦	⑥								
E421/5/6	-490322 Näheinrichtung, Stichabstand 5 mm, schaltbare Nadelstangen, Nadelstärke Nm 110-140, Stichlänge max. 6 mm, für mittelschweres Nähgut. Sewing equipment, seam distance 5 mm, needle bar rocking mechanism, needle size Nm 110-140, stitch length max. 6 mm, for medium weight material.			0867 E42106 5	0867 200210	0867 140010	0867 140040	2,2 x 3,2	0867 210210	0367 222243	0067 222333	0867 230574	0867 230564	5	134-35/130
E424/6/9	-490322 Näheinrichtung, Stichabstand 6 mm, schaltbare Nadelstangen, Nadelstärke Nm 110-140, Stichlänge max. 9 mm, für mittelschweres Nähgut. Sewing equipment, seam distance 6 mm, needle bar rocking mechanism, needle size Nm 110-140, stitch length max. 9 mm, for medium weight material.			0867 E42409 6	0867 200400	0867 140010	0867 140040	2,2 x 3,2	0867 210220	0768 222664	0768 222264	0867 230554	0867 230544	6	134-35/130
E424/8/9	-490322 Näheinrichtung, Stichabstand 8 mm, schaltbare Nadelstangen, Nadelstärke Nm 110-140, Stichlänge max. 9 mm, für mittelschweres Nähgut. Sewing equipment, seam distance 8 mm, needle bar rocking mechanism, needle size Nm 110-140, stitch length max. 9 mm, for medium weight material.			0867 E42409 8	0867 200410	0867 140050	0867 140060	2,2 x 3,2	0867 210230	0768 222674	0768 222274	0867 230534	0867 230524	8	134-35/130



E-Nr. E-No.	Für Unterklasse / For Subclass	Abb.-Nr. Fig.No.	Verwendungszweck / Use	Material No. / Material Nr.	Stichplatte Throat plate			Transporteur Feed dog				Presserfuß Presser foot		Transp. Fuß Feeding foot				
					① Stichplatte / Throat plate	⑦ Schieber, links / Slide, left	⑥ Schieber, rechts / Slide, right	Stichlochgröße / Stich hole size mm	Sägeverzahnung / Serrated mm	Säge-schrägverzahnung / Serrated, oblique mm	Kreuzverzahnung / Cross toothed mm	Dachverzahnung / Roof-shaped mm	Drückerfuß / Presser foot	Unverzahnung / Non toothed	Hüpfersfuß, kreuzverz. / Skipping f., cross toothed	Ausgleichfuß / Compensating foot	Kreuzverzahnung / Cross toothed mm	Unverzahnung / Non toothed
E721/4	-290020-70; -290040-70; -290122-70; -290322-70; -290342-70 Näheinrichtung, Nadelabstand 4 mm, Nadelstärke Nm 110-140, Stichlänge max. 6 mm, für mittelschweres Nähgut. Sewing equipment, needle gauge 4 mm, needle size Nm 110-140, stitch length max. 6 mm, for medium weight material.			0867 E72106 4	0867 200200	0867 142410	0867 142430	2,2 x 3,2	0867 210200			0367 222473			0067 222323	4	0867 230114	134-35/130
E721/5	-290020-70; -290040-70; -290122-70; -290322-70; -290342-70 Näheinrichtung, Nadelabstand 5 mm, Nadelstärke Nm 110-140. Stichlänge max. 6 mm, für mittelschweres Nähgut. Sewing equipment, needle gauge 5 mm, needle size Nm 110-140. Stitch length max. 6 mm, for medium weight material			0867 E72106 5	0867 200210	0867 142410	0867 142430	2,2 x 3,2	0867 210210			0367 222243			0067 222333	5	0867 230124	134-35/130
E721/6	-290020-70; -290040-70; -290122-70; -290322-70; -290342-70 Näheinrichtung, Nadelabstand 6 mm, Nadelstärke Nm 110-140, Stichlänge max. 6 mm, für mittelschweres Nähgut. Sewing equipment, needle gauge 6 mm, needle size Nm 110-140, stitch length max. 6 mm, for medium weight material.			0867 E72106 6	0867 200220	0867 142410	0867 142430	2,2 x 3,2	0867 210220			0367 222093			0067 222343	6	0867 230134	134-35/130
E721/8	-290020-70; -290040-70; -290122-70; -290322-70; -290342-70 Näheinrichtung, Nadelabstand 8 mm, Nadelstärke Nm 110-140, Stichlänge max. 6 mm, für mittelschweres Nähgut. Sewing equipment, needle gauge 8 mm, needle size Nm 110-140, stitch length max. 6 mm, for medium weight material.			0867 E72106 8	0867 200230	0867 142440	0867 142450	2,2 x 3,2	0867 210230			0367 222103			0067 222353	8	0867 230144	134-35/130
E721/10	-290020-70; -290040-70; -290122-70; -290322-70; -290342-70 Näheinrichtung, Nadelabstand 10 mm, Nadelstärke Nm 110-140, Stichlänge max. 6 mm, für mittelschweres Nähgut. Sewing equipment, needle gauge 10 mm, needle size Nm 110-140, stitch length max. 6 mm, for medium weight material.			0867 E72106 10	0867 200240	0867 142440	0867 142450	2,2 x 3,2	0867 210240			0367 222013			0067 222363	10	0867 230154	134-35/130



E-Nr. E-No.	Für Unterklasse / For Subclass	Abb.-Nr. Fig.No.	Verwendungszweck / Use	Material No. / Material Nr.	Stichplatte Throat plate			Transporteur Feed dog				Presserfuß Presser foot		Transp. Fuß Feeding foot					
					① Stichplatte / Throat plate	⑦ Schieber, links / Slide, left	⑥ Schieber, rechts / Slide, right	Stichlochgröße / Stich hole size mm	Sägeverzahnung / Serrated mm	Säge-schrägverzahnung / Serrated, oblique mm	Kreuzverzahnung / Cross toothed mm	Dachverzahnung / Roof-shaped mm	Drückerfuß / Presser foot	Unverzahnung / Non toothed	Hüpfersfuß, kreuzverz. / Skipping f., cross toothed	Ausgleichfuß / Compensating foot	Kreuzverzahnung / Cross toothed mm	Unverzahnung / Non toothed	⑤ Nadelabstand / Needle distance
E721/12	-290020-70; -290040-70; -290122-70; -290322-70; -290342-70 Näheinrichtung, Nadelabstand 12 mm, Nadelstärke Nm 110-140, Stichlänge max. 6 mm, für mittelschweres Nähgut. Sewing equipment, needle gauge 12 mm, needle size Nm 110-140, stitch length max. 6 mm, for medium weight material.			0867 E72106 12	0867 200250	0867 142460	0867 142470	2,2 x 3,2	0867 210250				0367 222313			0067 222393	12	0867 230164	134-35/130
E721/14	-290020-70; -290040-70; -290122-70; -290322-70; -290342-70 Näheinrichtung, Nadelabstand 14 mm, Nadelstärke Nm 110-140, Stichlänge max. 6 mm, für mittelschweres Nähgut. Sewing equipment, needle gauge 14 mm, needle size Nm 110-140, stitch length max. 6 mm, for medium weight material.			0867 E72106 14	0867 200260	0867 142480	0867 142470	2,2 x 3,2	0867 210260				0367 222323			0067 222413	14	0867 230174	134-35/130
E721/16	-290020-70; -290040-70; -290122-70; -290322-70; -290342-70 Näheinrichtung, Nadelabstand 16 mm, Nadelstärke Nm 110-140, Stichlänge max. 6 mm, für mittelschweres Nähgut Sewing equipment, needle gauge 16 mm, needle size Nm 110-140, stitch length max. 6 mm, for medium weight material.			0867 E72106 16	0867 200270	0867 142480	0867 142490	2,2 x 3,2	0867 210270				0367 222333			0067 222423	16	0867 230184	134-35/130
E721/18	-290020-70; -290040-70; -290122-70; -290322-70; -290342-70 Näheinrichtung, Nadelabstand 18 mm, Nadelstärke Nm 110-140, Stichlänge max. 6 mm, für mittelschweres Nähgut. Sewing equipment, needle gauge 18 mm, needle size Nm 110-140, stitch length max. 6 mm, for medium weight material.			0867 E72106 18	0867 200280	0867 142480	0867 142490	2,2 x 3,2	0867 210280				0367 222533			0067 222433	18	0867 230194	134-35/130
E721/20	-290020-70; -290040-70; -290122-70; -290322-70; -290342-70 Näheinrichtung, Nadelabstand 20 mm, Nadelstärke Nm 110-140, Stichlänge max. 6 mm, für mittelschweres Nähgut. Sewing equipment, needle gauge 20 mm, needle size Nm 110-140, stitch length max. 6 mm, for medium weight material.			0867 E72106 20	0867 200290	0867 142500	0867 142510	2,2 x 3,2	0867 210290				0367 222543			0067 222443	20	0867 230204	134-35/130



E-Nr. E-No. Abb.-Nr. Fig.No.	Für Unterklasse / For Subclass Verwendungszweck / Use	Material No. / Material Nr.	Stichplatte Throat plate			Stichlochgröße / Stich hole size mm	Sägeverzahnung / Serrated mm	Säge-schrägverzahnung / Serrated, oblique mm	Kreuzverzahnung / Cross toothed mm	Dachverzahnung / Roof-shaped mm	Drückerfuß / Presser foot	Unverzahnung / Non toothed	Hüpfersfuß, kreuzverz. / Skipping f., cross toothed	Ausgleichfuß / Compensating foot	Kreuzverzahnung / Cross toothed mm	Unverzahnung / Non toothed	Nadelabstand / Needle distance	Nadelhalter / Needle holder	Nadelsystem / -dicke / Needle system / -size
			①	⑦	⑥														
E721/22	-290020-70; -290040-70; -290122-70; -290322-70; -290342-70 Näheinrichtung, Nadelabstand 22 mm, Nadelstärke Nm 110-140, Stichlänge max. 6 mm, für mittelschweres Nähgut. Sewing equipment, needle gauge 22 mm, needle size Nm 110-140, stitch length max. 6 mm, for medium weight material.	0867 E72106 22	0867 200300	0867 142500	0867 142510	2,2 x 3,2	0867 210300			0367 222413					0067 222773	22	0867 230214	134-35/130	
E721/50	-290020-70; -290040-70; -290122-70; -290322-70; -290342-70 Näheinrichtung, Nadelabstand 50 mm, Nadelstärke Nm 110-140, Stichlänge max. 6 mm, für mittelschweres Nähgut. Sewing equipment, needle gauge 50 mm, needle size Nm 110-140, stitch length max. 6 mm, for medium weight material.	0867 E72106 50	0867 200310	0867 142520	0867 142530	2,2 x 3,2	0867 210310			0367 223293					0367 223283	50	0867 230304	134-35/130	
E722/6/9	-290020-70; -290040-70; -290122-70; -290322-70; -290342-70 Näheinrichtung zum Aussteppen von Schließnähten, Nadelabstand 6 mm, Nadelstärke Nm 110-140, Stichlänge max. 9 mm, für mittelschweres Nähgut. Sewing equipment for topstitching of closing seams, needle gauge 6 mm, needle size Nm 110-140, stitch length max. 9 mm, for medium weight material.	0867 E72209 6	0867 200400	0867 142410	0867 142430	2,2 x 3,2	0867 210220			0768 222123					0768 222264	6	0867 230134	134-35/130	
E722/8/6	-290020-70; -290040-70; -290122-70; -290322-70; -290342-70 Näheinrichtung zum Aussteppen von Schließnähten, Nadelabstand 8 mm, Nadelstärke Nm 110-140, Stichlänge max. 6 mm, für mittelschweres Nähgut. Sewing equipment for topstitching of closing seams, needle gauge 8 mm, needle size Nm 110-140, stitch length max. 6 mm, for medium weight material.	0867 E72206 8	0867 200230	0867 142440	0867 142450	2,2 x 3,2	0867 210230			0768 222133					0768 222274	8	0867 230144	134-35/130	
E722/8/9	-290020-70; -290040-70; -290122-70; -290322-70; -290342-70 Näheinrichtung zum Aussteppen von Schließnähten, Nadelabstand 8 mm, Nadelstärke Nm 110-140, Stichlänge max. 9 mm, für mittelschweres Nähgut. Sewing equipment for topstitching of closing seams, needle gauge 8 mm, needle size Nm 110-140, stitch length max. 9 mm, for medium weight material.	0867 E72209 8	0867 200410	0867 142440	0867 142450	2,2 x 3,2	0867 210230			0768 222133					0768 222274	8	0867 230144	134-35/130	



E-Nr. E-No.	Für Unterklasse / For Subclass	Abb.-Nr. Fig.No.	Verwendungszweck / Use	Material No. / Material Nr.	Stichplatte Throat plate			Transporteur Feed dog				Presserfuß Presser foot	Transp. Fuß Feeding foot							
					①	⑦	⑥				②	④		③						
E722/10/6	-290020-70; -290040-70; -290122-70; -290322-70; -290342-70 Näheinrichtung zum Aussteppen von Schließnähten, Nadelabstand 10 mm, Nadelstärke Nm 110-140, Stichlänge max. 6 mm, für mittelschweres Nähgut. Sewing equipment for topstitching of closing seams, needle gauge 10 mm, needle size Nm 110-140, stitch length max. 6 mm, for medium weight material.			0867 E72206 10	0867 200240	0867 142440	0867 142450	2,2 x 3,2	0867 210240			0768 222143			0768 222284			10	0867 230154	134-35/130
E722/10/9	-290020-70; -290040-70; -290122-70; -290322-70; -290342-70 Näheinrichtung zum Aussteppen von Schließnähten, Nadelabstand 10 mm, Nadelstärke Nm 140-180, Stichlänge max. 9 mm, für mittelschweres Nähgut. Sewing equipment for topstitching of closing seams, needle gauge 10 mm, needle size Nm 140-180, stitch length max. 9 mm, for medium weight material.			0867 E72209 10	0867 200420	0867 142440	0867 142450	2,8 x 3,7	0867 210450			0768 222143			0768 222404			10	0867 230154	134-35/160
E722/10/12	-290020-70; -290040-70; -290122-70; -290322-70; -290342-70 Näheinrichtung zum Aussteppen von Schließnähten, Nadelabstand 10 mm, Nadelstärke Nm 140-180, Stichlänge max. 12 mm, für mittelschweres Nähgut. Sewing equipment for topstitching of closing seams, needle gauge 10 mm, needle size Nm 140-180, stitch length max. 12 mm, for medium weight material.			0867 E72212 10	0867 200450	0867 142440	0867 142450	2,8 x 3,7	0867 210450			0768 222143			0768 222404			10	0867 230154	134-35/160
E722/12/9	-290020-70; -290040-70; -290122-70; -290322-70; -290342-70 Näheinrichtung zum Aussteppen von Schließnähten, Nadelabstand 12 mm, Nadelstärke Nm 140-180, Stichlänge max. 9 mm, für mittelschweres Nähgut. Sewing equipment for topstitching of closing seams, needle gauge 12 mm, needle size Nm 140-180, stitch length max. 9 mm, for medium weight material.			0867 E72209 12	0867 200430	0867 142460	0867 142470	2,8 x 3,7	0867 210460			0768 222153			0768 222434			12	0867 230164	134-35/160



E-Nr. E-No. Abb.-Nr. Fig.No.	Für Unterklasse / For Subclass Verwendungszweck / Use	Material No. / Material Nr.	Stichplatte Throat plate			Transporteur Feed dog				Presserfuß Presser foot	Transp. Fuß Feeding foot	⑤	Nadelhalter/ Needle holder	Nadelsystem/-dicke / Needle system/-size	
			①	⑦	⑥	②	③	④	③						
E722/12/12	-290020-70; -290040-70; -290122-70; -290322-70; -290342-70 Näheinrichtung zum Aussteppen von Schließnähten, Nadelabstand 12 mm, Nadelstärke Nm 140-180, Stichtlänge max. 12 mm, für mittelschweres Nähgut. Sewing equipment for topstitching of closing seams, needle gauge 12 mm, needle size Nm 140-180, stitch length max. 12 mm, for medium weight material.	0867 E72212 12	0867 200460	0867 142460	0867 142470	2,8 x 3,7	0867 210460			0768 222153		0768 222434	12	0867 230164	134-35/160
E722/14/12	-290020-70; -290040-70; -290122-70; -290322-70; -290342-70 Näheinrichtung zum Aussteppen von Schließnähten, Nadelabstand 14 mm, Nadelstärke Nm 140-180, Stichtlänge max. 12 mm, für mittelschweres Nähgut. Sewing equipment for topstitching of closing seams, needle gauge 14 mm, needle size Nm 140-180, stitch length max. 12 mm, for medium weight material.	0867 E72212 14	0867 200470	0867 142460	0867 142470	2,8 x 3,7	0867 210470			0867 222163		0768 222464	14	0867 230174	134-35/160
E723/10	-290020-70; -290040-70; -290122-70; -290322-70; -290342-70 Näheinrichtung zum Einnähen von Reißverschlüssen, Nadelabstand 10 mm, Nadelstärke Nm 110-140, Stichtlänge max. 6 mm, für mittelschweres Nähgut. Sewing equipment for inserting zippers, needle gauge 10 mm, needle size Nm 110-140, stitch length max. 6 mm, for medium weight material.	0867 E72306 10	0867 200950	0867 142440	0867 142450	∅ 1,7	0867 210950			0367 222510		0067 224103	10	0867 230154	134-35/130
E723/12	-290020-70; -290040-70; -290122-70; -290322-70; -290342-70 Näheinrichtung zum Einnähen von Reißverschlüssen, Nadelabstand 12 mm, Nadelstärke Nm 110-140, Stichtlänge max. 6 mm, für mittelschweres Nähgut. Sewing equipment for inserting zippers, needle gauge 12 mm, needle size Nm 110-140, stitch length max. 6 mm, for medium weight material.	0867 E72306 12	0867 200960	0867 142460	0867 142470	∅ 2	0867 210960			0367 222373		0067 223223	12	0867 230164	134-35/130



E-Nr. E-No.	Für Unterklasse / For Subclass	Abb.-Nr. Fig.No.	Verwendungszweck / Use	Material No. / Material Nr.	Stichplatte	Transporteur				Presserfuß	Transp. Fuß										
					Throat plate	Feed dog				Presser foot	Feeding foot										
					①	⑦	⑥		②	④	③										
					Stichplatte / Throat plate	Schieber, links / Slide, left	Schieber, rechts / Slide, right	Stichlochgröße / Stitch hole size mm	Sägeverzahnung / Serrated	Säge-schrägverzahnung / Serrated, oblique mm	Kreuzverzahnung / Cross toothed mm	Dachverzahnung / Roof-shaped mm	Drückerfuß / Presser foot	Unverzahnung / Non toothed	Hüpfertfuß, kreuzverz. / Skipping f., cross toothed	Ausgleichfuß / Compensating foot	Kreuzverzahnung / Cross toothed mm	Unverzahnung / Non toothed	Nadelabstand / Needle distance	Nadelhalter / Needle holder	Nadelsystem / -dicke / Needle system / -size
E724/6/9	-290122-70; -290322-70; -290342-70 Näheinrichtung zum Aussteppen von Schließnähten, Nadelabstand 6 mm, Nadelstärke Nm 110-140, Stichtlänge max. 9 mm, für mittelschweres Nähgut. Sewing equipment for topstitching of closing seams, needle gauge 6 mm, needle size Nm 110-140, stitch length max. 9 mm, for medium weight material.			0867 E72409 6	0867 200400	0867 142410	0867 142430	2,2 x 3,2	0867 210220				0768 222664			0768 222264			6	0867 230134	134-35/130
E724/8/9	-290122-70; -290322-70; -290342-70 Näheinrichtung zum Aussteppen von Schließnähten, Nadelabstand 8 mm, Nadelstärke Nm 110-140, Stichtlänge max. 9 mm, für mittelschweres Nähgut. Sewing equipment for topstitching of closing seams, needle gauge 8 mm, needle size Nm 110-140, stitch length max. 9 mm, for medium weight material.			0867 E72409 8	0867 200410	0867 142440	0867 142450	2,2 x 3,2	0867 210230				0768 222674			0768 222274			8	0867 230144	134-35/130
E724/10/9	-290122-70; -290322-70; -290342-70 Näheinrichtung zum Aussteppen von Schließnähten, Nadelabstand 10 mm, Nadelstärke Nm 110-140, Stichtlänge max. 9 mm, für mittelschweres Nähgut. Sewing equipment for topstitching of closing seams, needle gauge 10 mm, needle size Nm 110-140, stitch length max. 9 mm, for medium weight material.			0867 E72409 10	0867 200420	0867 142440	0867 142450	2,2 x 3,2	0867 210240				0768 222684			0768 222284			10	0867 230154	134-35/130
E724/12/9	-290122-70; -290322-70; -290342-70 Näheinrichtung zum Aussteppen von Schließnähten, Nadelabstand 12 mm, Nadelstärke Nm 110-140, Stichtlänge max. 9 mm, für mittelschweres Nähgut. Sewing equipment for topstitching of closing seams, needle gauge 12 mm, needle size Nm 110-140, stitch length max. 9 mm, for medium weight material.			0867 E72409 12	0867 200430	0867 142460	0867 142470	2,2 x 3,2	0867 210250				0768 222694			0768 222294			12	0867 230164	134-35/130



E-Nr. E-No.	Für Unterklasse / For Subclass	Abb.-Nr. Fig.No.	Verwendungszweck / Use	Material No. / Material Nr.	Stichplatte Throat plate			Transporteur Feed dog				Presserfuß Presser foot		Transp. Fuß Feeding foot				
					①	⑦	⑥	②	③	④	⑤	⑥	⑦	⑧	⑨			
E724/8/12	-290122-70; -290322-70; -290342-70 Näheinrichtung zum Aussteppen von Schließnähten, Nadelabstand 8 mm, Nadelstärke Nm 140-180, Stichlänge max. 12 mm, für mittelschweres Nähgut. Sewing equipment for topstitching of closing seams, needle gauge 8 mm, needle size Nm 140-180, stitch length max. 12 mm, for medium weight material.			0867 E72412 8	0867 200440	0867 142440	0867 142450	2,8 x 3,7	0867 210440			0867 220054		0768 222374		8	0867 230144	134-35/160
E724/10/12	-290122-70; -290322-70; -290342-70 Näheinrichtung zum Aussteppen von Schließnähten, Nadelabstand 10 mm, Nadelstärke Nm 140-180, Stichlänge max. 12 mm, für mittelschweres Nähgut. Sewing equipment for topstitching of closing seams, needle gauge 10 mm, needle size Nm 140-180, stitch length max. 12 mm, for medium weight material.			0867 E72412 10	0867 200450	0867 142440	0867 142450	2,8 x 3,7	0867 210450			0867 220064		0768 222404		10	0867 230154	134-35/160
E724/12/12	-290122-70; -290322-70; -290342-70 Näheinrichtung zum Aussteppen von Schließnähten, Nadelabstand 12 mm, Nadelstärke Nm 140-180, Stichlänge max. 12 mm, für mittelschweres Nähgut. Sewing equipment for topstitching of closing seams, needle gauge 12 mm, needle size Nm 140-180, stitch length max. 12 mm, for medium weight material.			0867 E72412 12	0867 200460	0867 142460	0867 142470	2,8 x 3,7	0867 210460			0867 220074		0768 222434		12	0867 230164	134-35/160
E724/14/12	-290122-70; -290322-70; -290342-70 Näheinrichtung zum Aussteppen von Schließnähten, Nadelabstand 14 mm, Nadelstärke Nm 140-180, Stichlänge max. 12 mm, für mittelschweres Nähgut. Sewing equipment for topstitching of closing seams, needle gauge 14 mm, needle size Nm 140-180, stitch length max. 12 mm, for medium weight material.			0867 E72412 14	0867 200470	0867 142460	0867 142470	2,8 x 3,7	0867 210470			0867 220084		0768 222464		14	0867 230174	134-35/160



E-Nr. E-No.	Für Unterklasse / For Subclass	Abb.-Nr. Fig.No.	Verwendungszweck / Use	Material No. / Material Nr.	Stichplatte	Transporteur	Presserfuß	Transp. Fuß								
					Throat plate				Feed dog	Presser foot	Feeding foot					
					①	⑦	⑥									
E751/8/9	-290020-70; -290040-70; -290122-70; -290322-70; -290342-70 Näheinrichtung asymmetrisch für allgemeine Näharbeiten. Die rechte Nadel befindet sich auf der Mitte der Nadelstange, um die Maschine auch als Einnadelmaschine einsetzen zu können. Nadelabstand 8 mm, Nadelstärke Nm 110-140, Stichlänge max. 9 mm, für mittelschweres Nähgut. Sewing equipment asymmetric for general sewing operations. The right needle is located on the needle bar center so that the machine could be also used as a single needle one. Needle gauge 8 mm, needle size Nm 110-140, stitch length max. 9 mm, for medium weight material.			0867 E75109 8	0867 200500	0867 142480	0867 142420	2,2 x 3,2	0867 210500		0867 220033		0867 220043	8	0867 230014	134-35/130
E751/10/9	-290020-70; -290040-70; -290122-70; -290322-70; -290342-70 Näheinrichtung asymmetrisch für allgemeine Näharbeiten. Die rechte Nadel befindet sich auf der Mitte der Nadelstange, um die Maschine auch als Einnadelmaschine einsetzen zu können. Nadelabstand 10 mm, Nadelstärke Nm 110-140, Stichlänge max. 9 mm, für mittelschweres Nähgut. Sewing equipment asymmetric for general sewing operations. The right needle is located on the needle bar center so that the machine could be also used as a single needle one. Needle gauge 10 mm, needle size Nm 110-140, stitch length max. 9 mm, for medium weight material.			0867 E75109 10	0867 200510	0867 142500	0867 142420	2,2 x 3,2	0867 210510		0467 222123		0467 222113	10	0867 230024	134-35/130
E751/12/9	-290020-70; -290040-70; -290122-70; -290322-70; -290342-70 Näheinrichtung asymmetrisch für allgemeine Näharbeiten. Die rechte Nadel befindet sich auf der Mitte der Nadelstange, um die Maschine auch als Einnadelmaschine einsetzen zu können. Nadelabstand 12 mm, Nadelstärke Nm 110-140, Stichlänge max. 9 mm, für mittelschweres Nähgut. Sewing equipment asymmetric for general sewing operations. The right needle is located on the needle bar center so that the machine could be also used as a single needle one. Needle gauge 12 mm, needle size Nm 110-140, stitch length max. 9 mm, for medium weight material.			0867 E75109 12	0867 200520	0867 142540	0867 142420	2,2 x 3,2	0867 210520		0467 222183		0467 222173	12	0867 230034	134-35/130



E-Nr. E-No.	Für Unterklasse / For Subclass	Abb.-Nr. Fig.No.	Verwendungszweck / Use	Material No. / Material Nr.	Stichplatte Throat plate		Transporteur Feed dog				Presserfuß Presser foot		Transp. Fuß Feeding foot				
					①	⑦	⑥										⑤
E751/14/9	-290020-70; -290040-70; -290122-70; -290322-70; -290342-70		Näheinrichtung asymmetrisch für allgemeine Näharbeiten. Die rechte Nadel befindet sich auf der Mitte der Nadelstange, um die Maschine auch als Einnadelmaschine einsetzen zu können. Nadelabstand 14 mm, Nadelstärke Nm 110-140, Stichlänge max. 9 mm, für mittelschweres Nähgut. Sewing equipment asymmetric for general sewing operations. The right needle is located on the needle bar center so that the machine could be also used as a single needle one. Needle gauge 14 mm, needle size Nm 110-140, stitch length max. 9 mm, for medium weight material.	0867 E75109 14	0867 200530	0867 142560	0867 142420	2,2 x 3,2	0867 210530			0467 222143		0467 222133	14	0867 230044	134-35/130

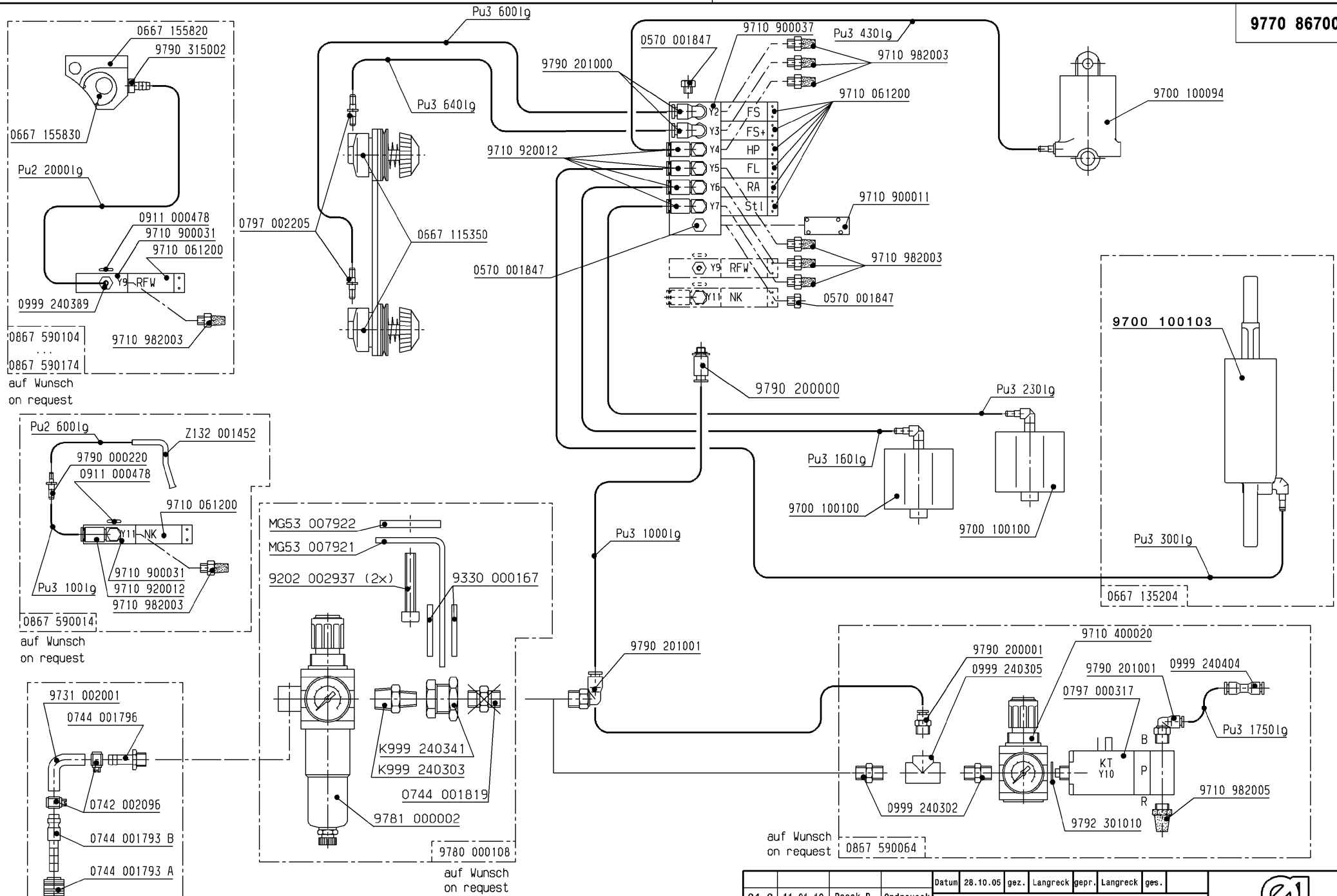

auf Wunsch
on request

auf Wunsch
on request

auf Wunsch
on request

auf Wunsch
on request

auf Wunsch
on request

Schlauch	Teile-Nr. (Meterware)
Hose	Part-No. (Yarded goods)
PU2	0699 979265
PU3	9731 005004

04.0	11.01.10	Pasek P.	Ondrousek
03.0	27.10.09	Schubert	Schubert
02.0	30.01.08	Schmid	Schubert
01.0	31.10.07	Schmid	Langreck
Änd.	Datum	gez.	gepr.

Datum	28.10.05	gez.	Langreck	gepr.	Langreck	gez.
Pneu.-Geräteplan für Pneu.-Elements-Plan for 0867-1903..						

DÜRKOPP ADLER AG
9770 867001
 Blatt 1 Blattz. 7

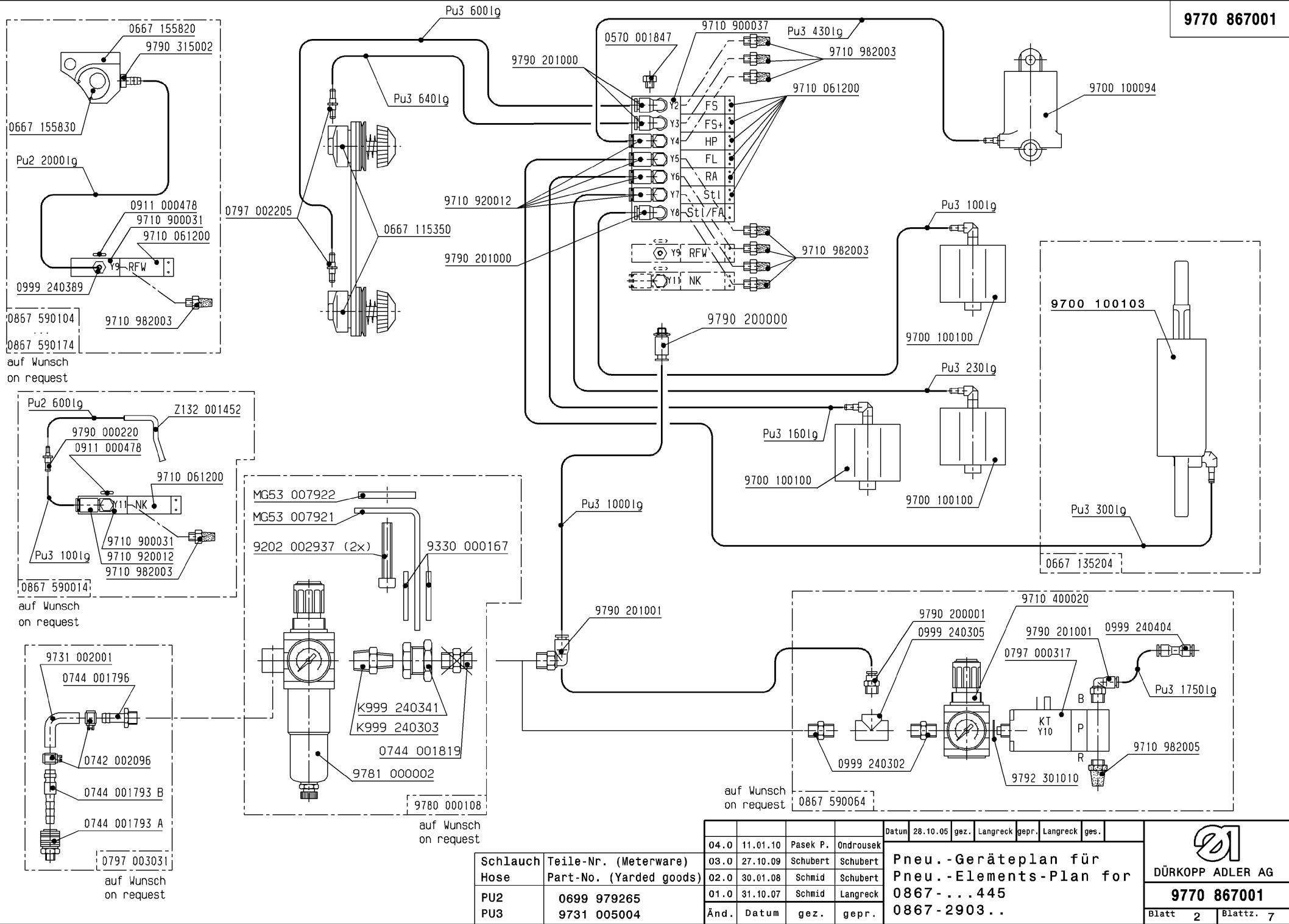

Schutzvermerk
DIN
A3
150 16016 beachten

Schlauch Hose	Teile-Nr. (Meterware) Part-No. (Yarded goods)
PU2	0699 979265
PU3	9731 005004

04.0	11.01.10	Pasek P.	Ondrousek
03.0	27.10.09	Schubert	Schubert
02.0	30.01.08	Schmid	Schubert
01.0	31.10.07	Schmid	Langreck
Änd.	Datum	gez.	gepr.

Datum 28.10.05 gez. Langreck gepr. Langreck ges.

**Pneu.-Geräteplan für
Pneu.-Elements-Plan for**
0867-...445
0867-2903..

DÜRKOPP ADLER AG
9770 867001
Blatt 2 Blattz. 7

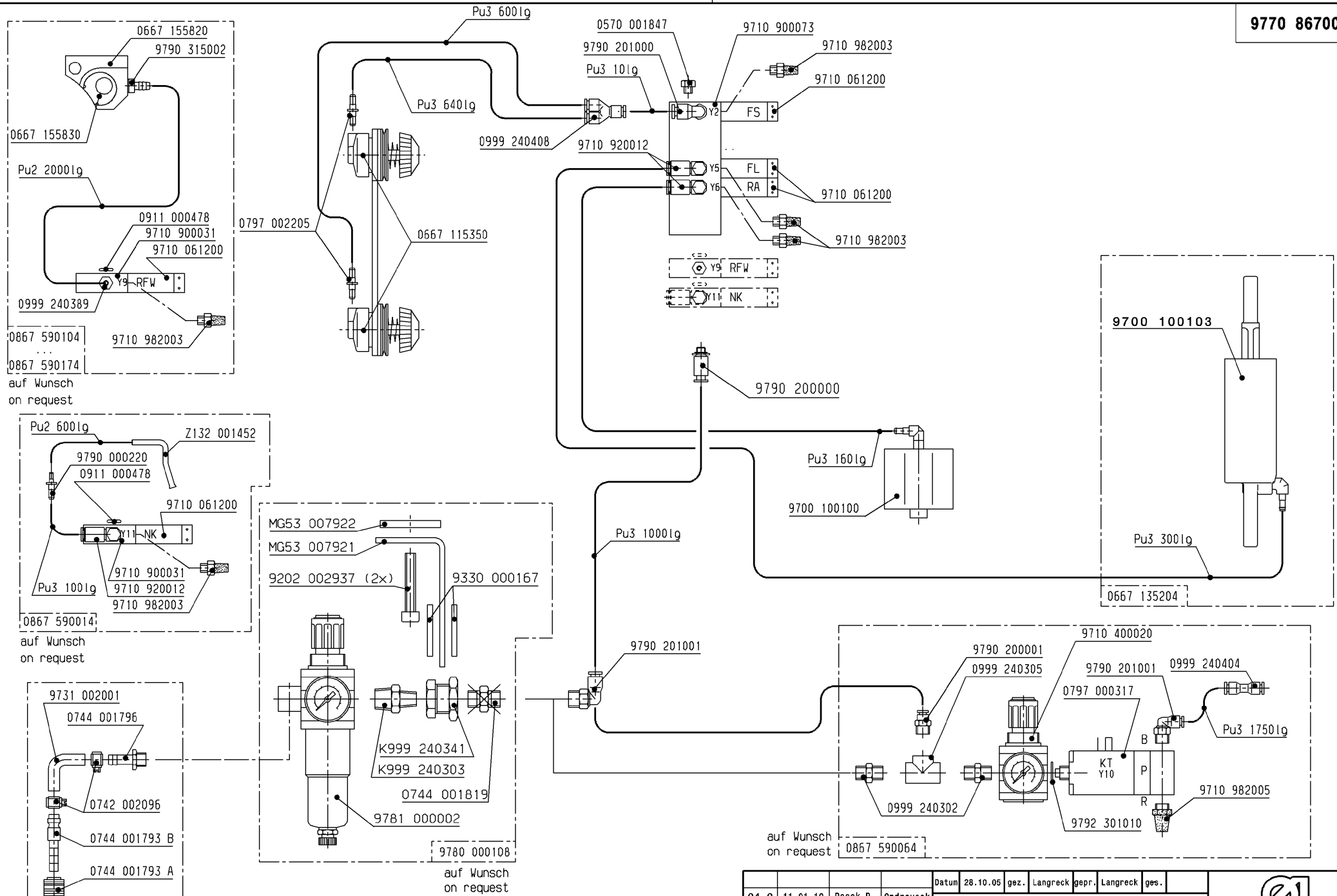

Schutzvermerk
DIN A3
150 16016 beachten

Schlauch Hose	Teile-Nr. (Meterware) Part-No. (Yarded goods)
PU2	0699 979265
PU3	9731 005004

04.0	11.01.10	Pasek P.	Ondrousek
03.0	27.10.09	Schubert	Schubert
02.0	30.01.08	Schmid	Schubert
01.0	31.10.07	Schmid	Langreck
Änd.	Datum	gez.	gepr.

Datum 28.10.05 gez. Langreck gepr. Langreck ges.
Pneu.-Geräteplan für
Pneu.-Elements-Plan for
 0867-190122
 0867-190142

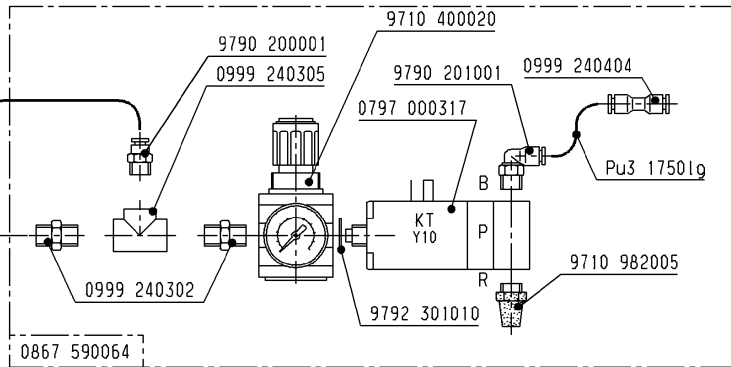
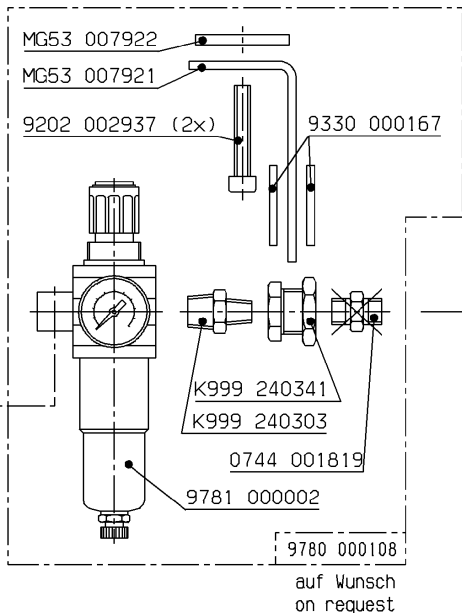
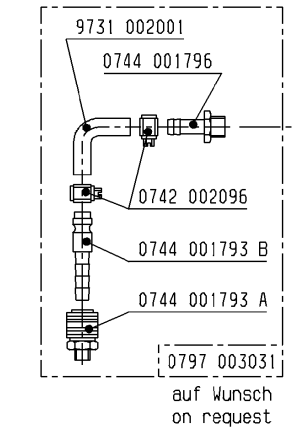
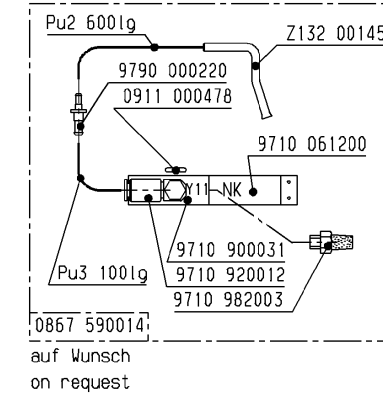
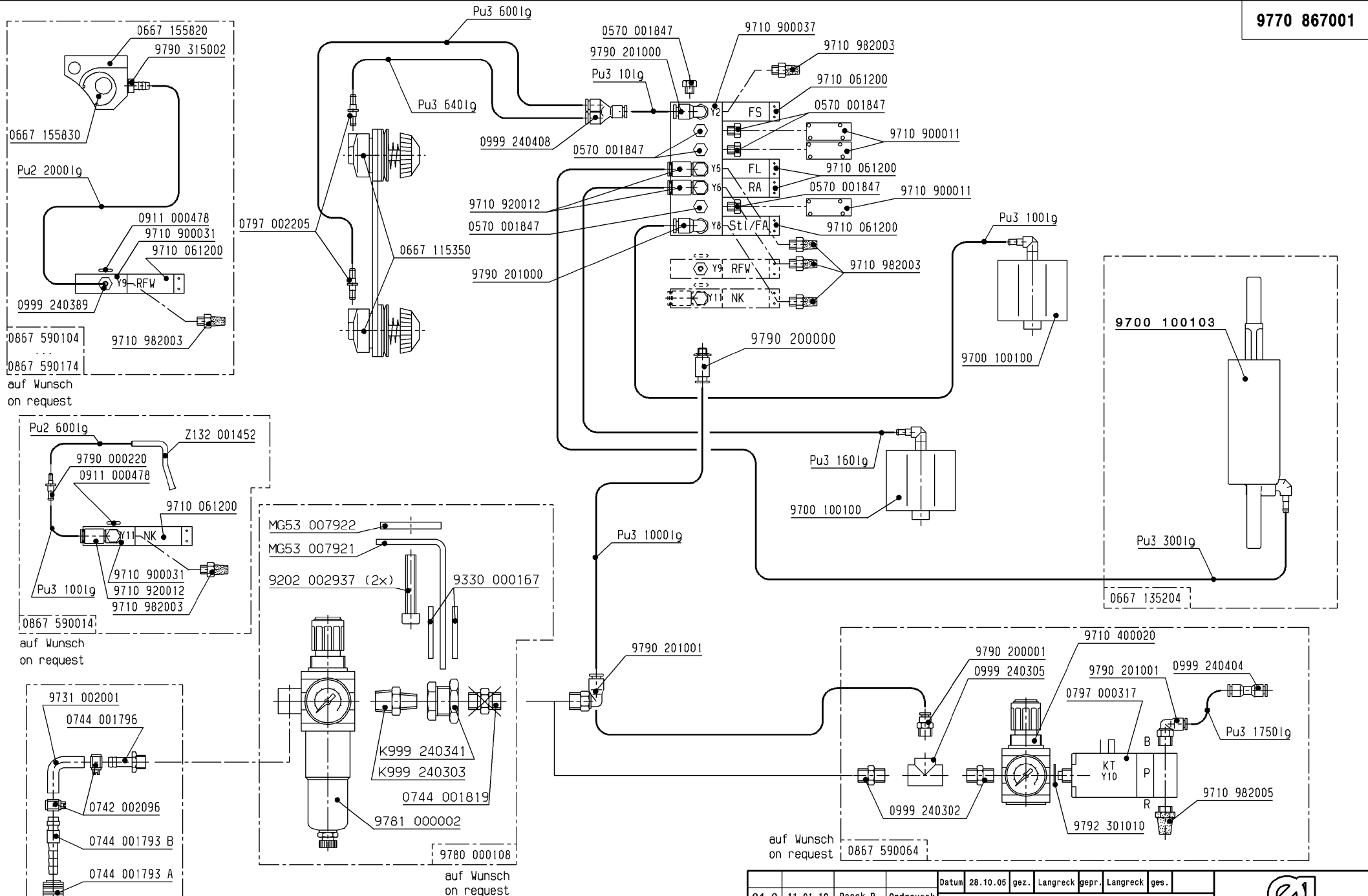

DÜRKOPP ADLER AG
9770 867001
 Blatt 3 Blattz. 7



Schlauch Hose	Teile-Nr. (Meterware) Part-No. (Yarded goods)
PU2	0699 979265
PU3	9731 005004

04.0	11.01.10	Pasek P.	Ondrousek
03.0	27.10.09	Schubert	Schubert
02.0	30.01.08	Schmid	Schubert
01.0	31.10.07	Schmid	Langreck
Änd.	Datum	gez.	gepr.

Datum	28.10.05	gez.	Langreck	gepr.	Langreck	gez.
Pneu.-Geräteplan für Pneu.-Elements-Plan for 0867-190145						

DÜRKOPP ADLER AG
9770 867001
 Blatt 4 | Blattz. 7

Schutzvermerk
 DIN A3
 150 16016 beachten

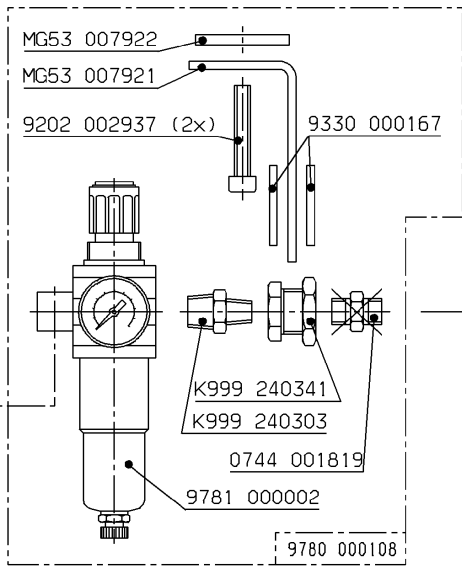
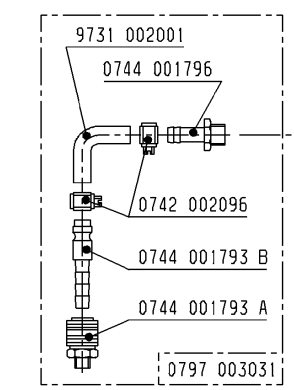
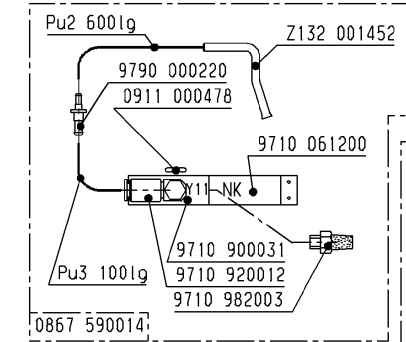
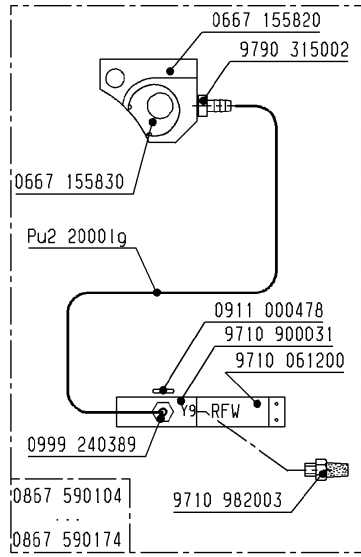
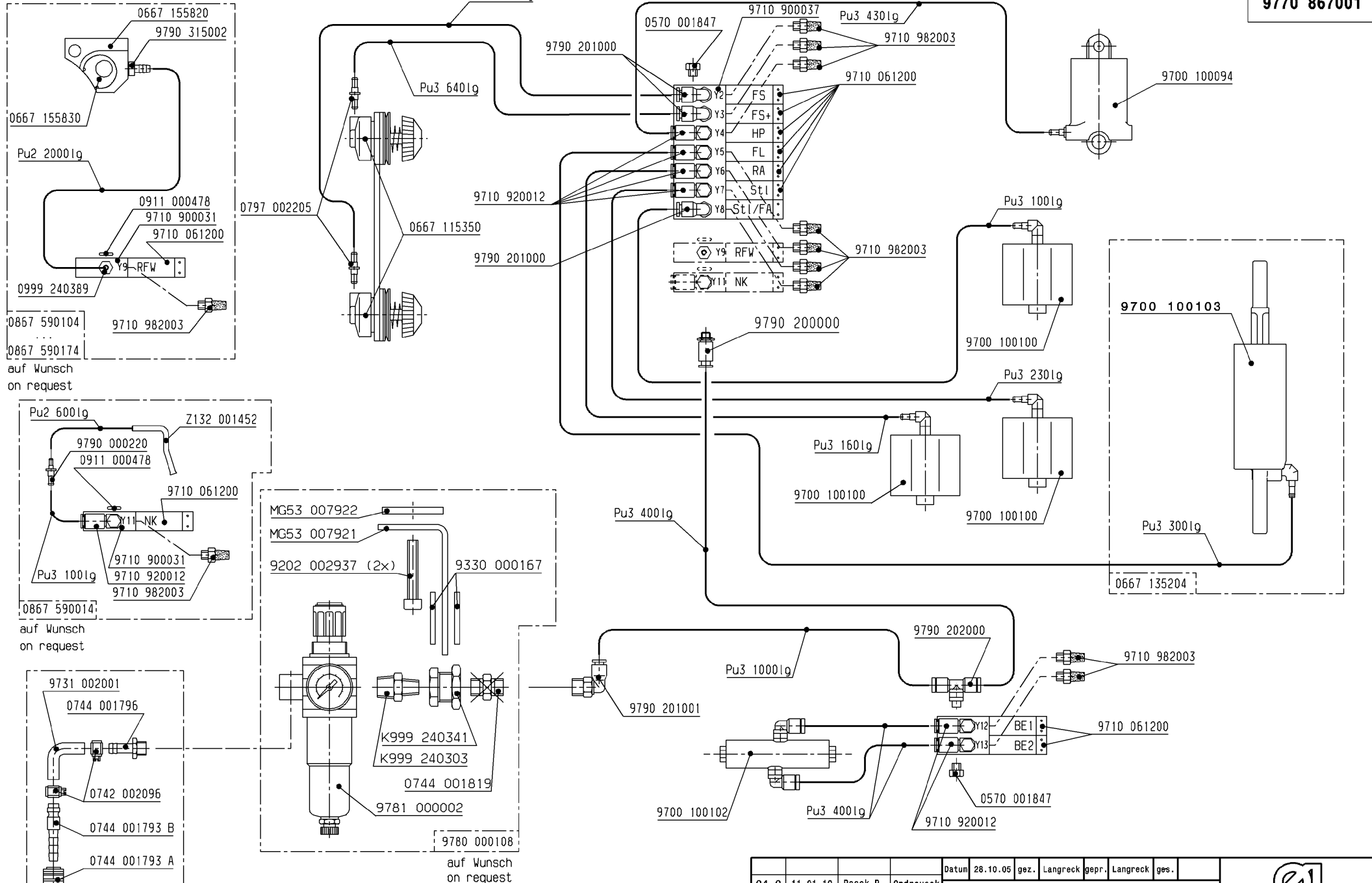

auf Wunsch
on request

auf Wunsch
on request

Schlauch Hose	Teile-Nr. (Meterware) Part-No. (Yarded goods)
PU2	0699 979265
PU3	9731 005004

04.0	11.01.10	Pasek P.	Ondrousek
03.0	27.10.09	Schubert	Schubert
02.0	30.01.08	Schmid	Schubert
01.0	31.10.07	Schmid	Langreck
Änd.	Datum	gez.	gepr.

Datum	28.10.05	gez.	Langreck	gepr.	Langreck	gez.
Pneu.-Geräteplan für						
Pneu.-Elements-Plan for						
0867-392342						

DÜRKOPP ADLER AG

9770 867001

Blatt 5 Blattz. 7

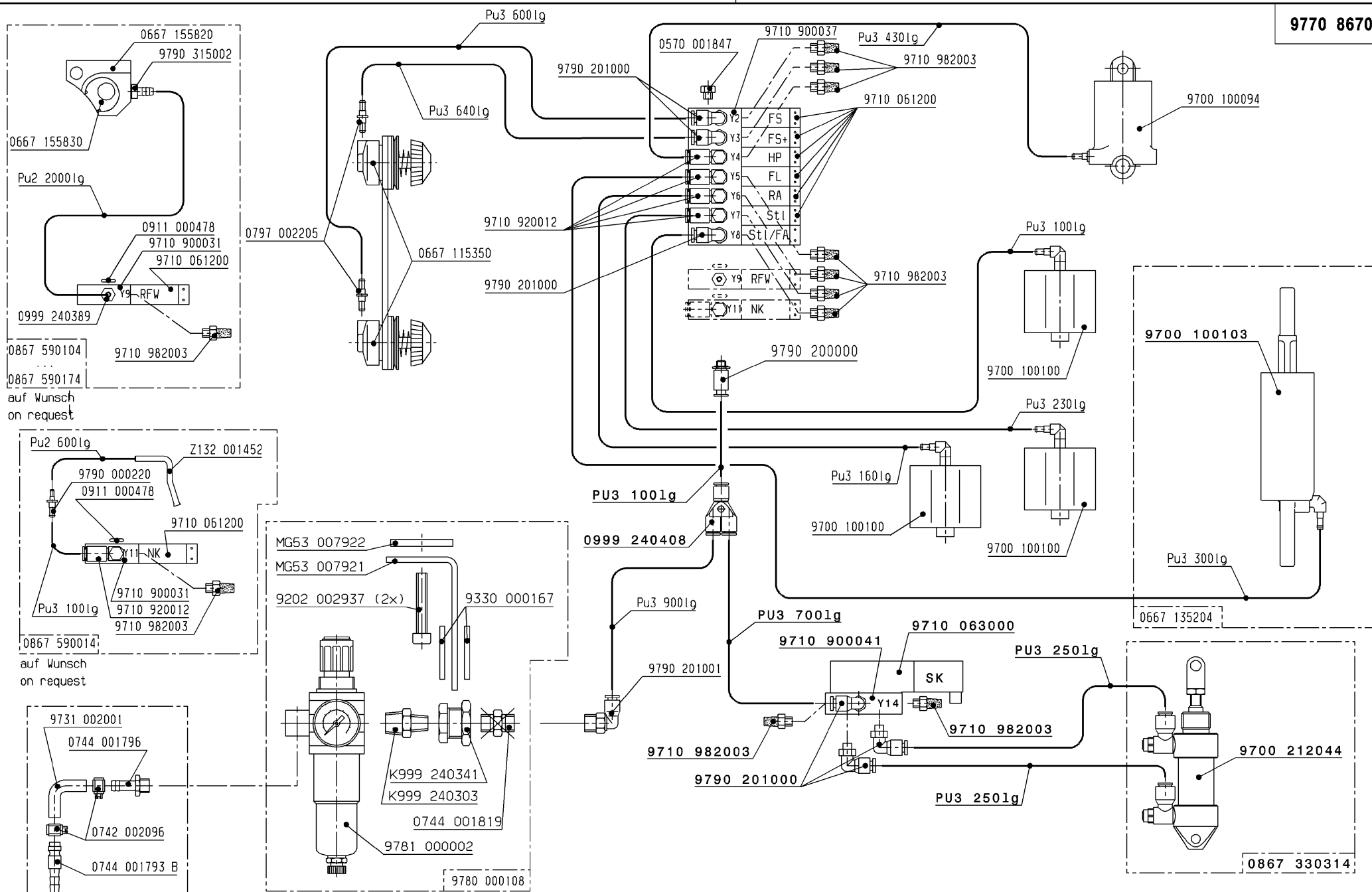

Schutzvermerk
DIN
A3
150 16016 beachten

Schlauch Hose	Teile-Nr. (Meterware) Part-No. (Yarded goods)
PU2	0699 979265
PU3	9731 005004

04.0	11.01.10	Pasek P.	Ondrousek
03.0	27.10.09	Schubert	Schubert
02.0	30.01.08	Schmid	Schubert
01.0	31.10.07	Schmid	Langreck
Änd.	Datum	gez.	gepr.

Datum	28.10.05	gez.	Langreck	gepr.	Langreck	gez.
Pneu.-Geräteplan für Pneu.-Elements-Plan for						
0867-393342 0867-394342						

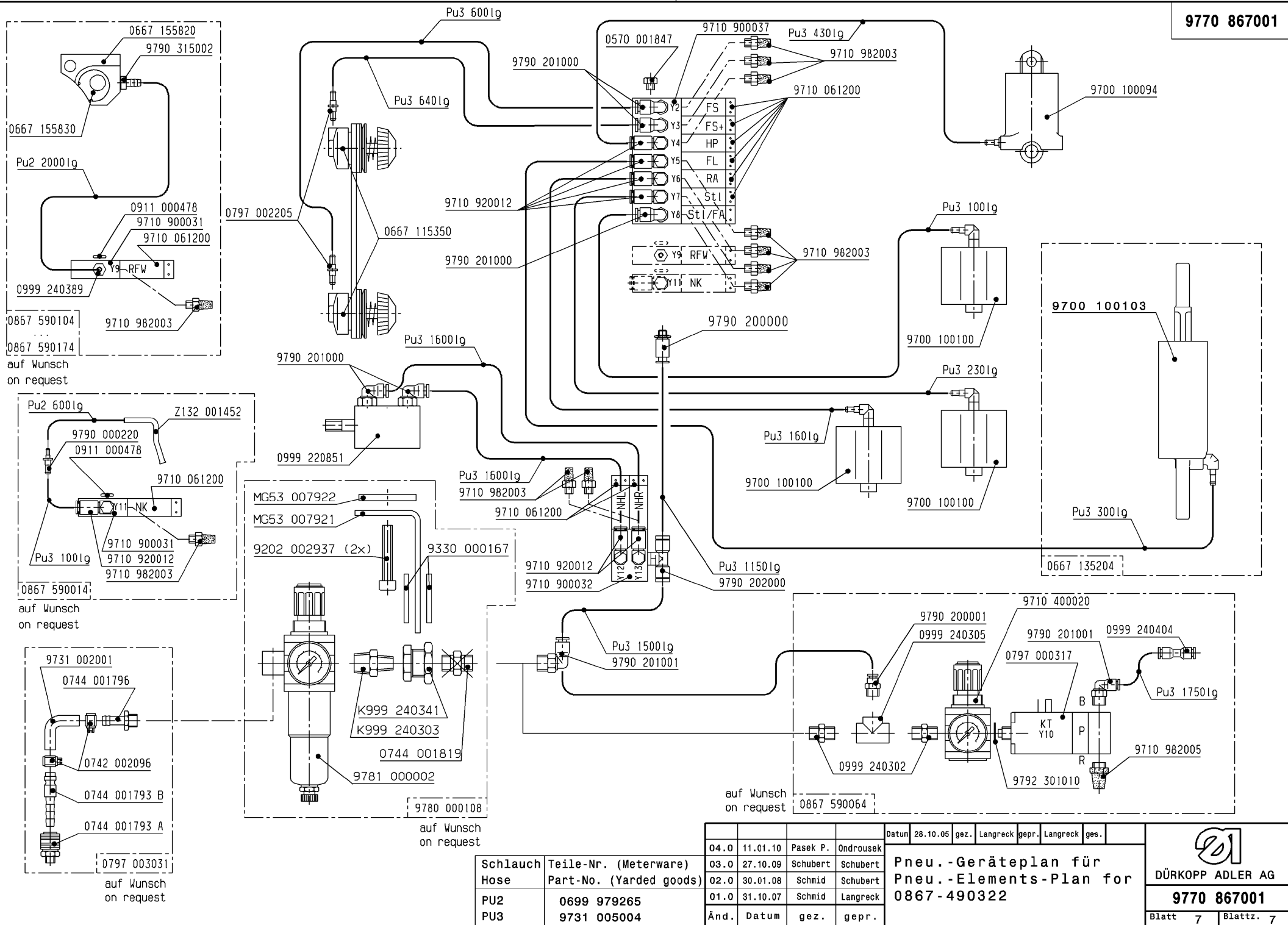

DÜRKOPP ADLER AG
9770 867001
 Blatt 6 Blattz. 7



Schlauch	Teile-Nr. (Meterware)
Hose	Part-No. (Yarded goods)
PU2	0699 979265
PU3	9731 005004

04.0	11.01.10	Pasek P.	Ondrousek
03.0	27.10.09	Schubert	Schubert
02.0	30.01.08	Schmid	Schubert
01.0	31.10.07	Schmid	Langreck
Änd.	Datum	gez.	gepr.

Datum	28.10.05	gez.	Langreck	gepr.	Langreck	gez.
<p>Pneu.-Geräteplan für Pneu.-Elements-Plan for 0867-490322</p>						

	
<p>DÜRKOPP ADLER AG</p>	
<p>9770 867001</p>	
Blatt 7	Blattz. 7

Schutzvermerk
DIN
A3

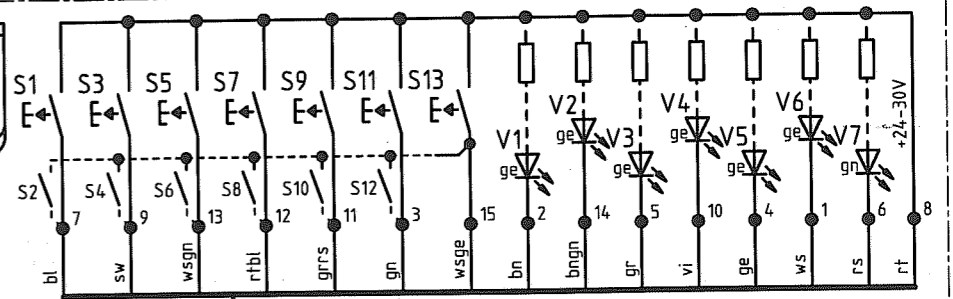
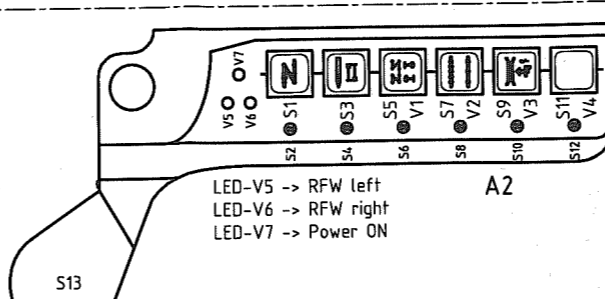
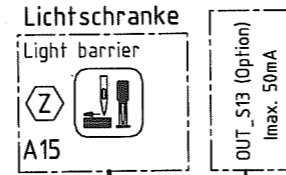
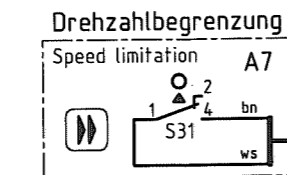
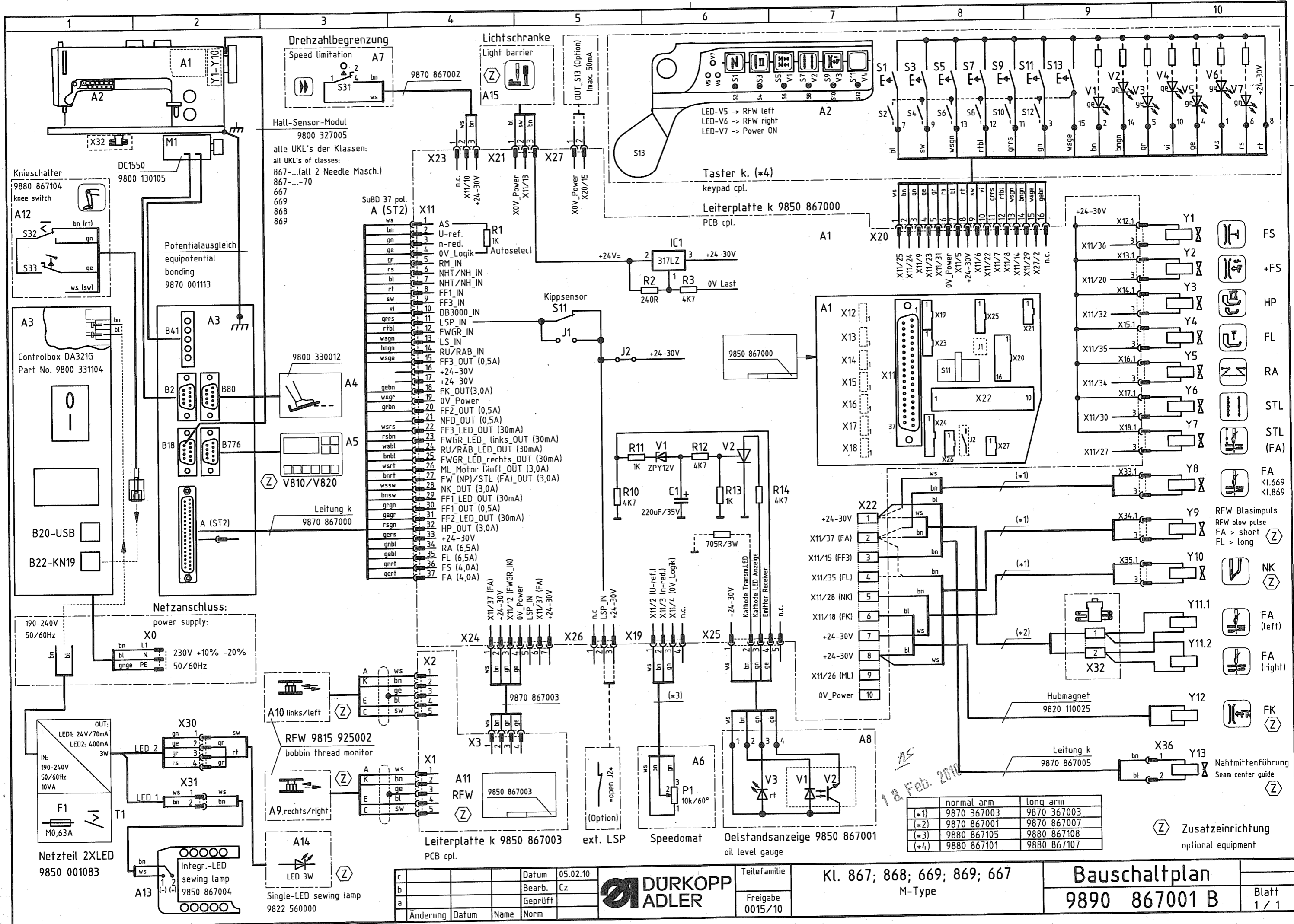

Hall-Sensor-Modul
9800 327005

alle UKL's der Klassen:
all UKL's of classes:
867-... (all 2 Needle Masch.)
867-...-70
667
669
868
869

- SubD 37 pol. A (ST2) X11
- 1 ws AS
 - 2 bn U-ref.
 - 3 gn n-red.
 - 4 ge OV_Logik
 - 5 gr RM_IN
 - 6 rs NHT/NH_IN
 - 7 bl NHT/NH_IN
 - 8 rt FF1_IN
 - 9 sw FF3_IN
 - 10 vi DB3000_IN
 - 11 grs LSP_IN
 - 12 rtbl FWGR_IN
 - 13 wsgn LS_IN
 - 14 bngn RU/RAB_IN
 - 15 wsge FF3_OUT (0,5A)
 - 16 +24-30V
 - 17 +24-30V
 - 18 gebn FK_OUT(3,0A)
 - 19 wsgn OV_Power
 - 20 grbn FF2_OUT (0,5A)
 - 21 wsrn NFD_OUT (0,5A)
 - 22 rsnb FF3_LED_OUT (30mA)
 - 23 wsbl FWGR_LED_OUT (30mA)
 - 24 wsrbl RU/RAB_LED_OUT (30mA)
 - 25 bnbl FWGR_LED_rechts (30mA)
 - 26 wsr ML_Motor läuft OUT (3,0A)
 - 27 bnrt FW (NP)/STL (FA)_OUT (3,0A)
 - 28 wssw NK_OUT (3,0A)
 - 29 bns FF1_LED_OUT (30mA)
 - 30 grgn FF2_LED_OUT (30mA)
 - 31 gegr HP_OUT (3,0A)
 - 32 rsgn +24-30V
 - 33 gers RA (6,5A)
 - 34 gnbl FL (6,5A)
 - 35 gebi FS (4,0A)
 - 36 gnrt FA (4,0A)
 - 37 gert

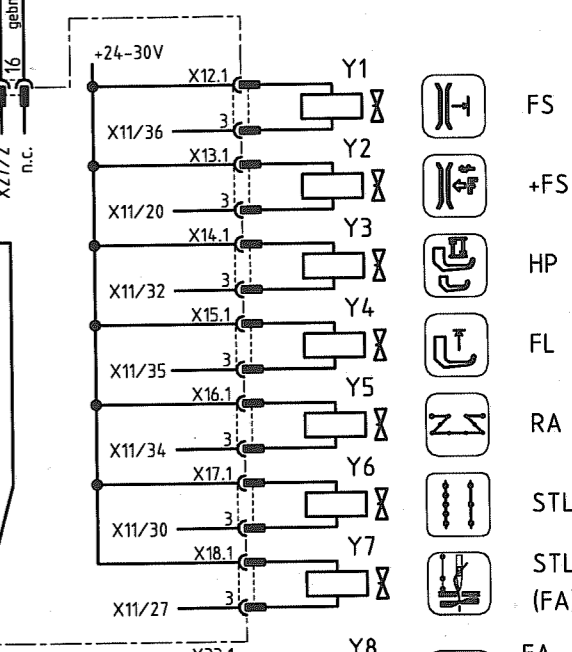
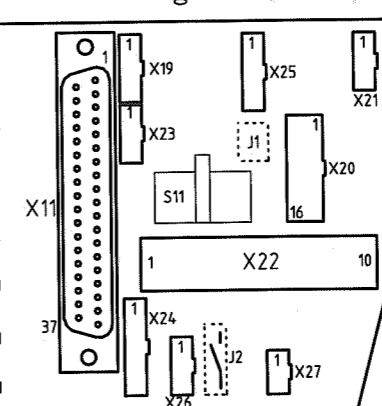
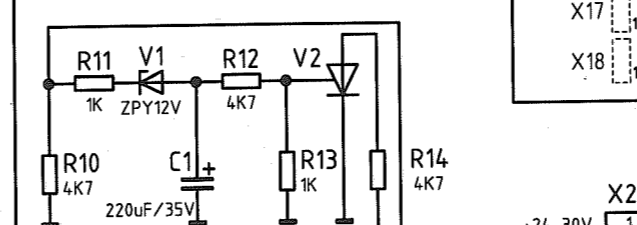
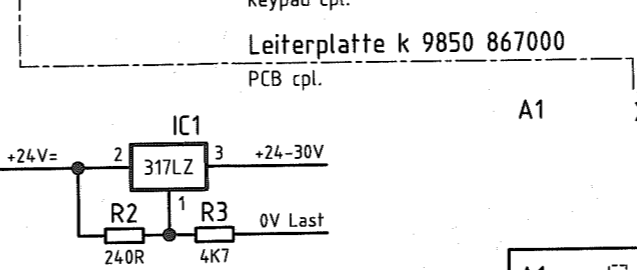

- FS
- +FS
- HP
- FL
- RA
- STL
- STL (FA)
- FA Kl.669 Kl.869
- RFW Blasiimpuls
- RFW blow pulse
- FA > short
- FL > long
- NK
- FA (left)
- FA (right)
- FK

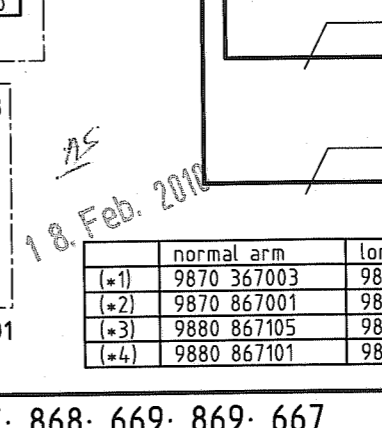
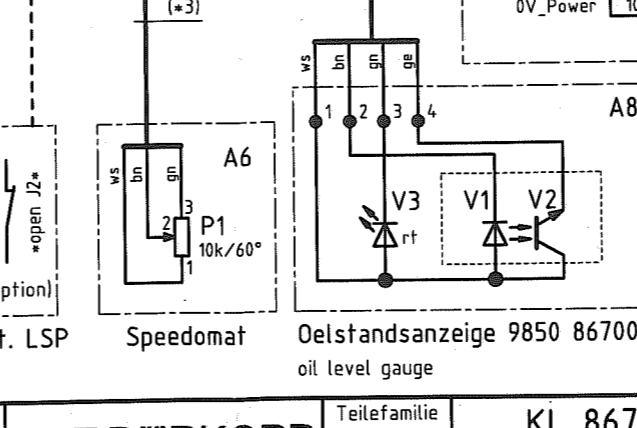
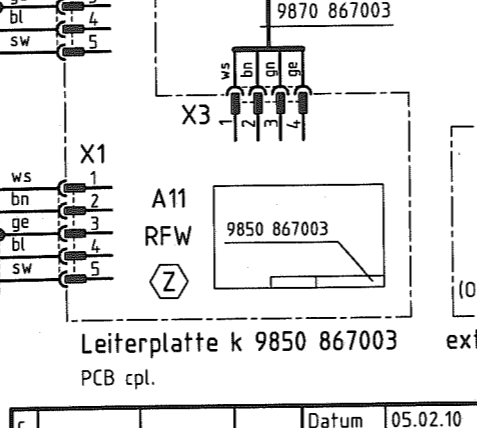
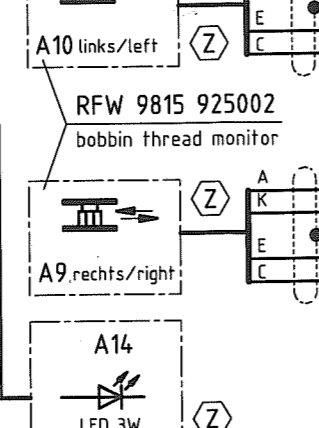
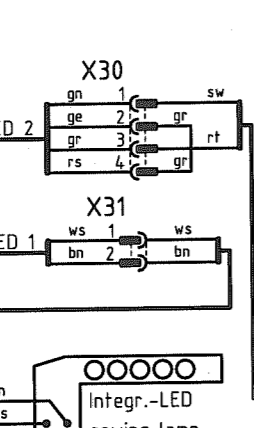
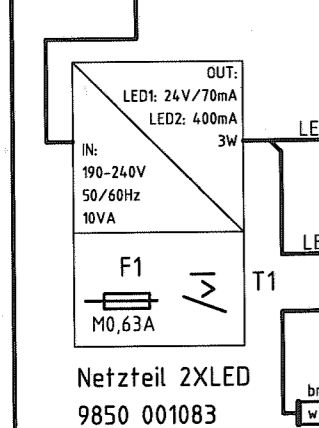
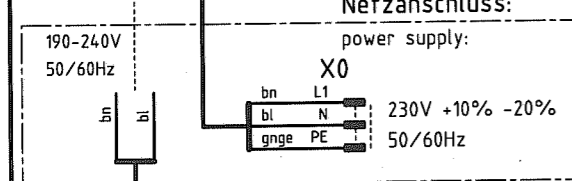
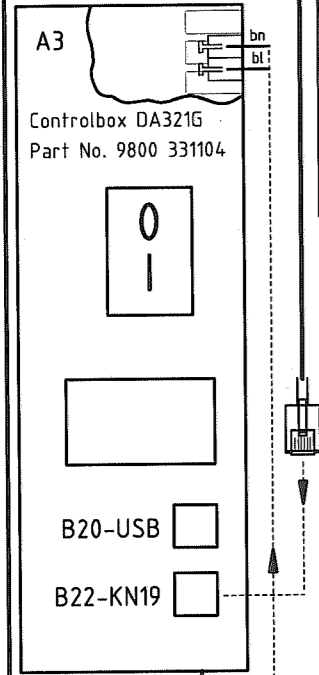
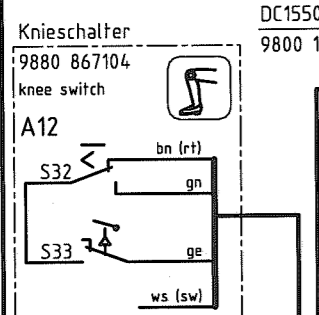

18. Feb. 2010

	normal arm	long arm
(*1)	9870 367003	9870 367003
(*2)	9870 867001	9870 867007
(*3)	9880 867105	9880 867108
(*4)	9880 867101	9880 867107

Z Zusatzeinrichtung
optional equipment

c	Datum	05.02.10
b	Bearb.	Cz
a	Geprüft	
	Anderung	Datum Name Norm

DÜRKOPP ADLER

Teilfamilie
Freigabe 0015/10

Kl. 867; 868; 669; 869; 667
M-Type

Bauschaltplan
9890 867001 B
Blatt 1 / 1