

PFAFF

5645-H

5646-H

Teileliste

List of parts

Liste de pièces

Lista de piezas

Die Inhaltsübersicht auf Seite 3 gibt einen Überblick über die Aufgliederung der Liste.
Die Teile sind so abgebildet, wie sie in der Maschine funktionsmäßig zusammengehören.
Die gestrichelten Abbildungen zeigen, wo die daneben abgebildeten Teile hingehören.
Die Einrahmungen auf den Bildseiten zeigen, aus welchen Einzelteilen sich die Gruppenteile zusammensetzen.
Nähwerkzeuge und Apparate sind der Unterklassen-Ausstattung zu entnehmen (siehe Anhang).
Die auf den Bildseiten verwendeten Schlüsselzeichen (□; 3; 6 usw.) sind in Register „0“ zusammengefaßt und erläutert.
Konstruktionsänderungen vorbehalten.

For the various sections of this catalogue, please refer to the "Contents" on page 3.
The parts are illustrated as they belong together in the machine.
The dashed illustrations show where the adjacent parts belong.
The framed-in sections on the illustration pages show the individual parts comprising a group.
For gauge parts and attachments please refer to the subclass listing (see appendix).
The keys used on the illustration pages (□; 3; 6 etc.) are listed and explained in section "0".
Subject to alterations in design.

La table des matières, page 3, donne un aperçu de la subdivision de la liste.
Les pièces figurent sur l'illustration comme elles vont ensemble.
Les figures en tirets montrent le lieu de montage des pièces figurant à côté.
Les parties encadrées sur les pages à illustrations représentent les pièces individuelles formant groupe.
Pour les organes de couture et les appareils, veuillez vous référer à la fiche équipement de sous-classes (voir en annexe).
Les symboles (□; 3; 6 etc.) utilisés sur les pages illustrées sont regroupés et expliqués au registre „0“.
Sous réserve de modifications.



En la página 3, bajo el título "contenido", puede verse un resumen de la división de la "lista de piezas".
Las piezas están ilustradas conforme se hallan montadas en la máquina.
Las figuras a base de líneas entrecortadas muestran dónde y cómo van montadas las piezas ilustradas al lado.
Los recuadros en las páginas ilustradas indican las piezas individuales de que se componen los grupos.
Para los órganos de costura y aparatos, véase la „Composición de las subclases" (en el anexo).
Los símbolos clave (□; 3; 6, etc.) utilizados en las páginas ilustradas se hallan recopilados y explicados en el registro „0".
Salvo modificaciones técnicas.

Register Section Registre Registro		Seite Page Página
	Schiermittel-Tabelle Table of lubricants Tableau des lubrifiants Tabla de lubricantes	5
0	Erläuterungen Explanations Légende Explicaciones	6
1	Kopfteile Needle head parts Pièces de tête Piezas de la cabeza	Pfaff 5645H-840/01-706/07 9
2	Armteile Arm parts Pièces de bras Piezas del brazo	Pfaff 5645H-840/01-706/07 11
3	Grundplattenteile Bedplate parts Pièces du plateau fondamental Piezas de la placa-base	Pfaff 5645H-840/01-706/07 16
4	Gehäuseteile Housing sections Parties du corps Piezas del cárter	Pfaff 5645H-840/01-706/07 20
5	Ergänzungsteile Complementary parts Pièces complémentaires Piezas especiales	Pfaff 5646H-840/02-706/07 24
6	Ergänzungsteile Complementary parts Pièces complémentaires Piezas especiales	Pfaff 5646H-840/04-706/07 24
7	Apparate-Antrieb Attachment drive Commande d'appareils Mecanismo para accionamiento de aparatos	-703/01 25
8	Kanten-Beschneideinrichtung Edge trimmer Couteau Recortador	-731/11 zur for -731/12 pour para Pfaff 5645H-840/01-706/07 26
9	Kanten-Beschneideinrichtung Edge trimmer Couteau Recortador	-733/12 31
10	Pneumatische Spannungslüftung Pneumatic tension release Débrayage pneumatique de la tension Interrupción neumática de la tension	-906/07 37
11	Presserfuß-Automatik Automatic presser foot lifter Relève-pied automatique Alzaprensatejas	-910/04 37
12	Stichverdichtungs-Einrichtung Stitch condensation mechanism Rétrécisseur de points Condensador de puntadas	-917/35 38
13	Schalteneinrichtung Switching system Dispositif de commande Mecanismo de mando	-918/09 39

Register Section Registre Registro		Seite Page Página
14	Blasvorrichtung Blower Dispositif à jet d'air Eyector de aire -920/05	40
15	Wartungseinheit Air filter / lubricator Conditionneur d'air comprimé Grupo acondicionador del aire comprimido -925/02	41
16	Wartungseinheit Air filter / lubricator Conditionneur d'air comprimé Grupo acondicionador del aire comprimido -925/03	42
17	Kettentrenn-Einrichtung Chain cutter Coupe-chainette Cortador de cadeneta -960/15	43
18	Fotozellensteuerung für Stichverdichtung Photocell control for condensed stitching Commande par cellule photo- électrique pour points rétrécis Mando por fotocélula para condensación de la puntada -971/45	Fotozelle Photocell Cellule photo-électrique Fotocélula -910/04 -917/35 -925/02 -960/15 44 37 38 41 43
19	Tastschalter mit Leitung Push-button with lead Interrupteur à poussoir, avec câble Interruptor pulsador con cable	45
20	Pneumatische Steuerung Pneumatic control Commande pneumatique Mando neumático	46
21	Zubehörteile Accessory parts Accessoires Accesorios	48
22	Motoranschlußsatz Motor connection kit Jeu de pièces à raccorder le moteur Juego de piezas de conexión del motor	53
23	Positionsgeber Synchronizer Synchronisateur Sincronizador zur for pour para Pfaff 5645H-913/52 Pfaff 5646H-913/52	55
24	Einstellehren Adjustment gauges Calibres Calibres de ajuste	55
25	Keilriemenscheiben-Tabelle Table of V-belt pulleys Tableau des poulies à gorge en V Tabla de poleas para correas en "V"	56
26	Nummernverzeichnis Numerical index Tableau des numéros Indice numérico	57
Anhang Appendix Annexe Anexo	Unterklassen-Ausstattung Subclass parts Composition des sous-classes Composición de las subclases	

**Lubrifiants
Lubricantes**

PFAFF 5645-H;5646-H

Öl Oil Huile Aceite	Mittelpunkts- Viskosität bei: Mean viscosity at: Viscosité moyenne à: Viscosidad media a:		Dichte bei: Density of: Densité à: Densidad a:		Bestellnummer für Behälter mit: Part number for can with: Numéro de commande pour récipients avec: Número de pedido para recipientes con:			
	°C	mm ² /s	°C	g/cm ³ (g/ml)	Liter Litre Litros			
280-1-120 144	40	22,0	15	0,865	80(ml)	91-027 630-91		
					0,25		91-129 916-91	
					1		91-129 917-91	
					5			91-129 919-91
					10			91-129 920-91

Fett Grease Graisse Grasa	Penetration Penetration Pénétration Penetración	Tropfpunkt Drip-point Point de suintement Punto de goteo	Bestellnummer für Behälter mit: Part number for can with: Numéro de commande pour récipients avec: Número de pedido para recipientes con:			
			mm/10	°C	kg	
280-1-120 247	220-250	185	0,5			
			1	280-1-120 247		

O

- Unterklassenabhängig, Teilenummer siehe Unterklassen-Ausstattung.
Subclas-dependent, for part number see subclass parts listing.
Fonction de la sous-classe; pour le numéro de la pièce, voir "Equipement de sous-classes".
Dependientes de la subclase, para el número de pieza véase "Dotación de subclases".
- 2 Markierung (Punkte, Striche oder Zahl) bei Bestellung angeben.
Marking (dots, strokes or numbers) to be stated on order.
Préciser les repères (points, traits ou chiffres) à la commande.
Señales (puntos, rayas o cifras), indíquese en los pedidos.
- 3 Geklebt
Part cemented
Pièce collée
Pieza pegada
- 3/1 Gesichert mit Loctite.
Secured with Loctite.
Bloqué par Loctite.
Asegurado con Loctite.
- 3/4 Selbstklebend
Self-adhesive
Auto-adhésive
Autoadhesiva
- 6 Nadeldicke und Spitzenform bei Bestellung angeben.
Needle size and style of point to be stated on order.
Préciser la grosseur de l'aiguille et la forme de la pointe à la commande.
Grosor de aguja y forma de la punta, indíquese en los pedidos.
- 26/10 Zur Stichlängenbegrenzung.
For stitch length limitation.
Pour la limitation de la longueur du point.
Para la limitación de largo de puntada.
- 27/5 Eingeklammerte Zahl = Länge in mm.
Number in brackets = length in mm.
Chiffre entre parenthèses = longueur en mm.
Cifra entre paréntesis = largura en mm.
- 32 Beim Einbau dieses Teiles wird für die Paßgenauigkeit zum Anschlußteil keine Garantie übernommen;
zweckmäßig vollständiges Aggregat bestellen.
No guarantee is assumed that this part will fit the mating part; it is best to order a complete
assembly.
Aucune garantie ne pourra être assurée quant à la précision d'ajustage de cette pièce avec la pièce
correspondante; il est indiqué de commander un mécanisme complet.
Al montar esta pieza no se asume garantía alguna en cuanto a la tolerancia y precisión de ajuste
respecto a la pieza correspondiente; por esta razón se recomienda pedir el grupo completo

- 32/1 Beim Einbau dieses Teiles ist Nacharbeit erforderlich.
When fitting this part re-work is required.
Retouches nécessaires au montage.
Al montar esta pieza hay que retocarla antes.
- 40/1 Füllen mit 280-1-120 144, Bestellnummer siehe Seite 5.
Top up with 280-1-120 144; for part number see page 5.
Remplir de 280-1-120 144; n° de commande, voir page 5.
Rellene con 280-1-120 144; para el número de pedido véase la página 5.
- 40/2 Tränken mit 280-1-120 144; Bestellnummer siehe Seite 5.
Soak with 280-1-120 144; for part number see page 5.
Imbiber d'huile 280-1-120 144; n° de commande, voir page 5.
Empape con aceite 280-1-120 144; para el número de pedido véase la página 5.
- 40/3 Fetten mit 280-1-120 247; Bestellnummer siehe Seite 5.
Grease with 280-1-120 247; for part number see page 5.
Graisser avec de la graisse 280-1-120 247; n° de commande, voir page 5.
Engrase con grasa 280-1-120 247; para el número de pedido véase la página 5.
- 40/5 Ölen mit 280-1-120 144; Bestellnummer siehe Seite 5.
Oil with 280-1-120 144; for part number see page 5.
Huiler par 280-1-120 144; n° de commande, voir page 5.
Lubrifique con 280-1-120 144; para el número de pedido véase la página 5.
- 90/1 Für Wechselstrom.
For single-phase A.C.
Pour du courant alternatif.
Para corriente alterna monofásica.
- 90/2 Für Drehstrom.
For three-phase A.C.
Pour du courant triphasé.
Para corriente trifásica.
- 90/3 Zur Motorbefestigung.
For fitting the motor.
Pour la fixation du moteur.
Para fijación del motor.
- 90/19 Wartungseinheit -925/.. erforderlich
Air Filter / lubricator -925/.. required.
Conditionneur d'air comprimé -925/.. requis.
Requiere el grupo acondicionador del aire comprimido -925/..
- 96 Länge angeben.
State length.
Préciser longueur.
Indíquese la largura.

O

- 96/3 Schlauch mit 3 mm Innendurchmesser, bei Bestellung Länge angeben.
Tube with 3 mm inside dia; length to be stated on order.
Flexible d'un diamètre intérieur de 3 mm; préciser la longueur.
Tubo flexible de 3 mm de diámetro interior; indiquese la largura en los pedidos.
- 96/4 Schlauch mit 4 mm Innendurchmesser, bei Bestellung Länge angeben.
Tube with 4 mm inside dia; length to be stated on order.
Flexible d'un diamètre intérieur de 4 mm; préciser la longueur.
Tubo flexible de 4 mm de diámetro interior; indiquese la largura en los pedidos.
- 96/6 Schlauch mit 6 mm Innendurchmesser, bei Bestellung Länge angeben.
Tube with 6 mm inside dia; length to be stated on order.
Flexible d'un diamètre intérieur de 6 mm; préciser la longueur.
Tubo flexible de 6 mm de diámetro interior; indiquese la largura en los pedidos.

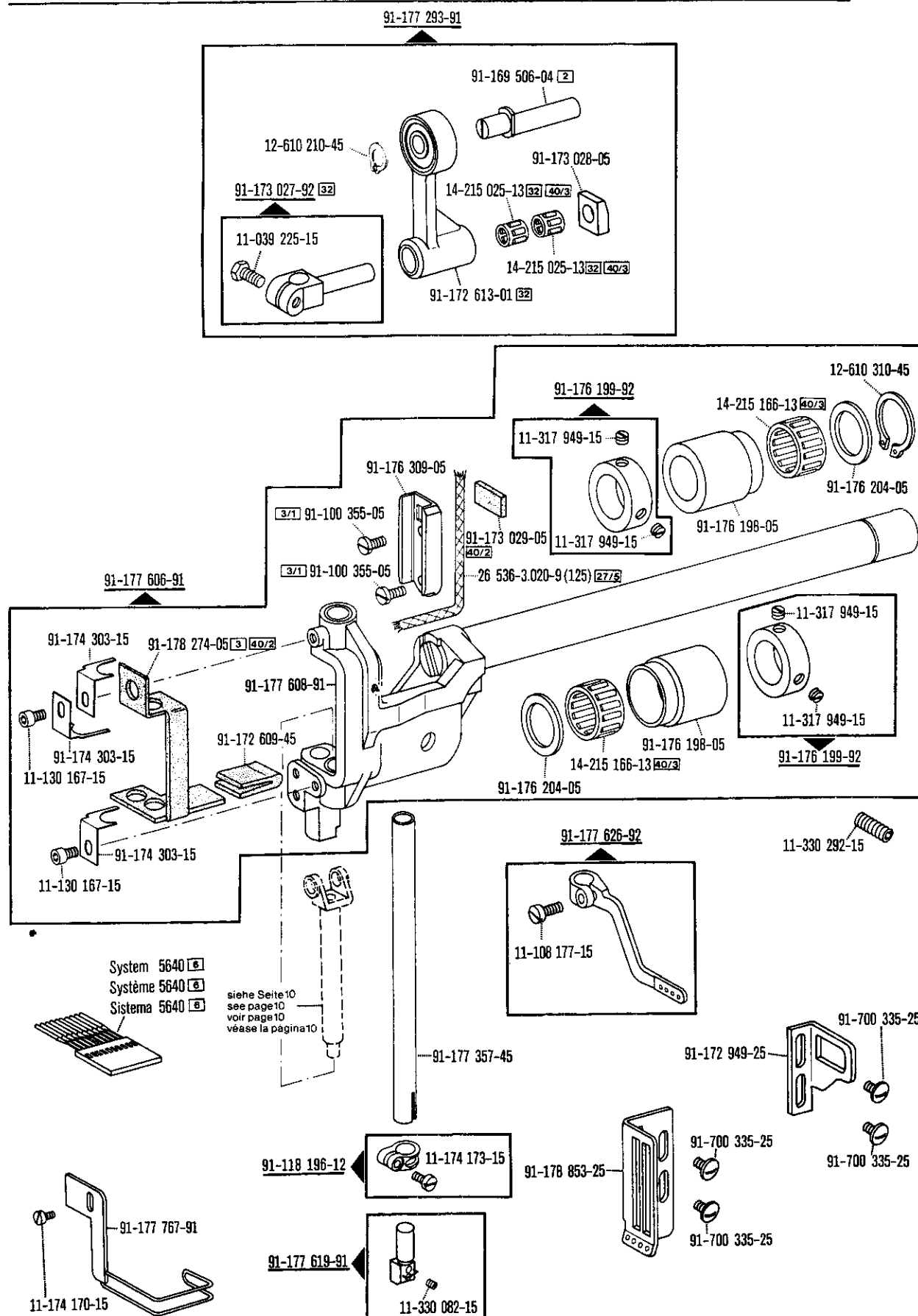

☐ siehe Erläuterungen Register 0
see explanations in section 0
voir légende registre 0
ver explicaciones del registro 0

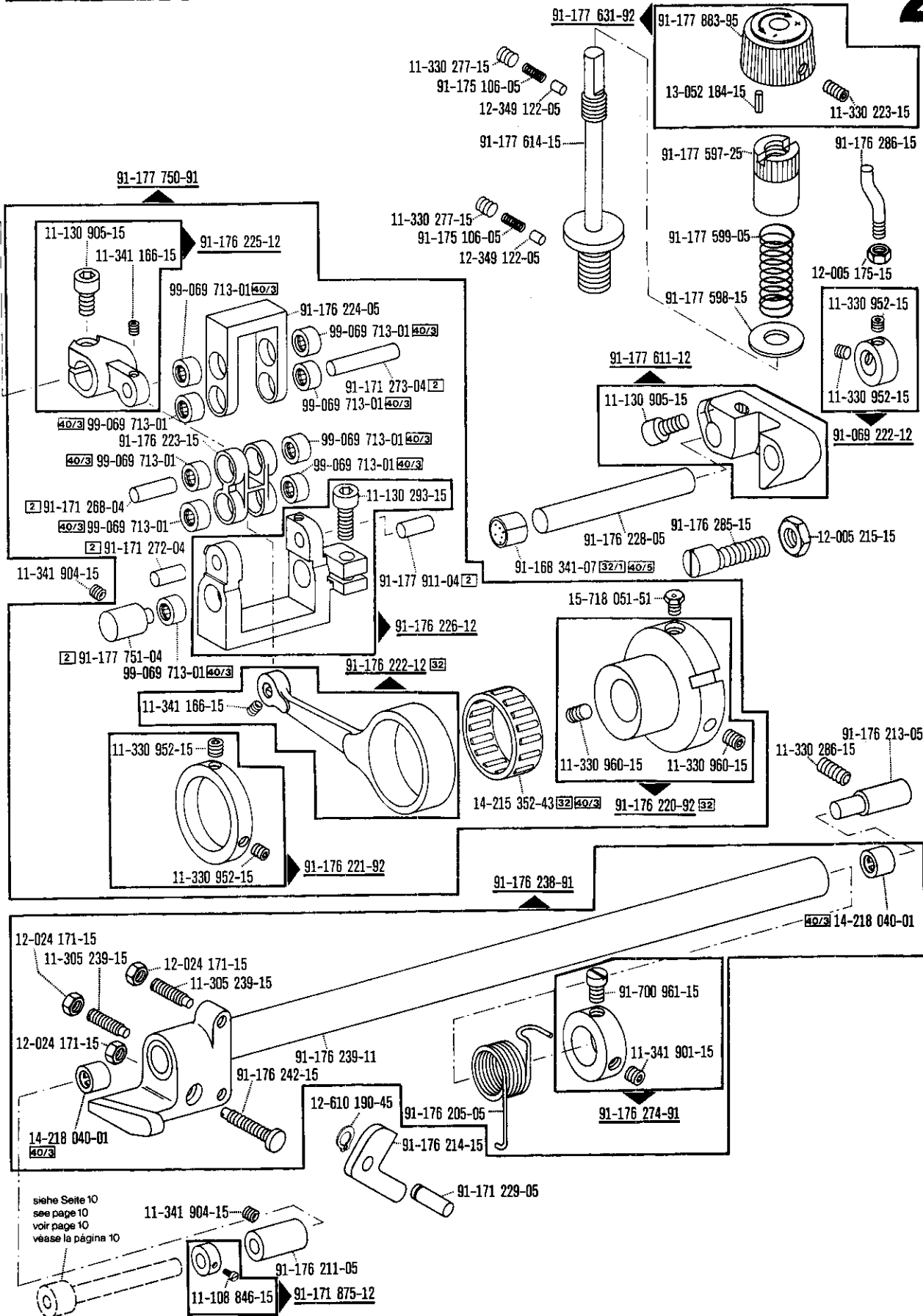

siehe Seite 10
 see page 10
 voir page 10
 véase la página 10

☐ siehe Erläuterungen Register O
 see explanations in section O
 voir légende registre O

2

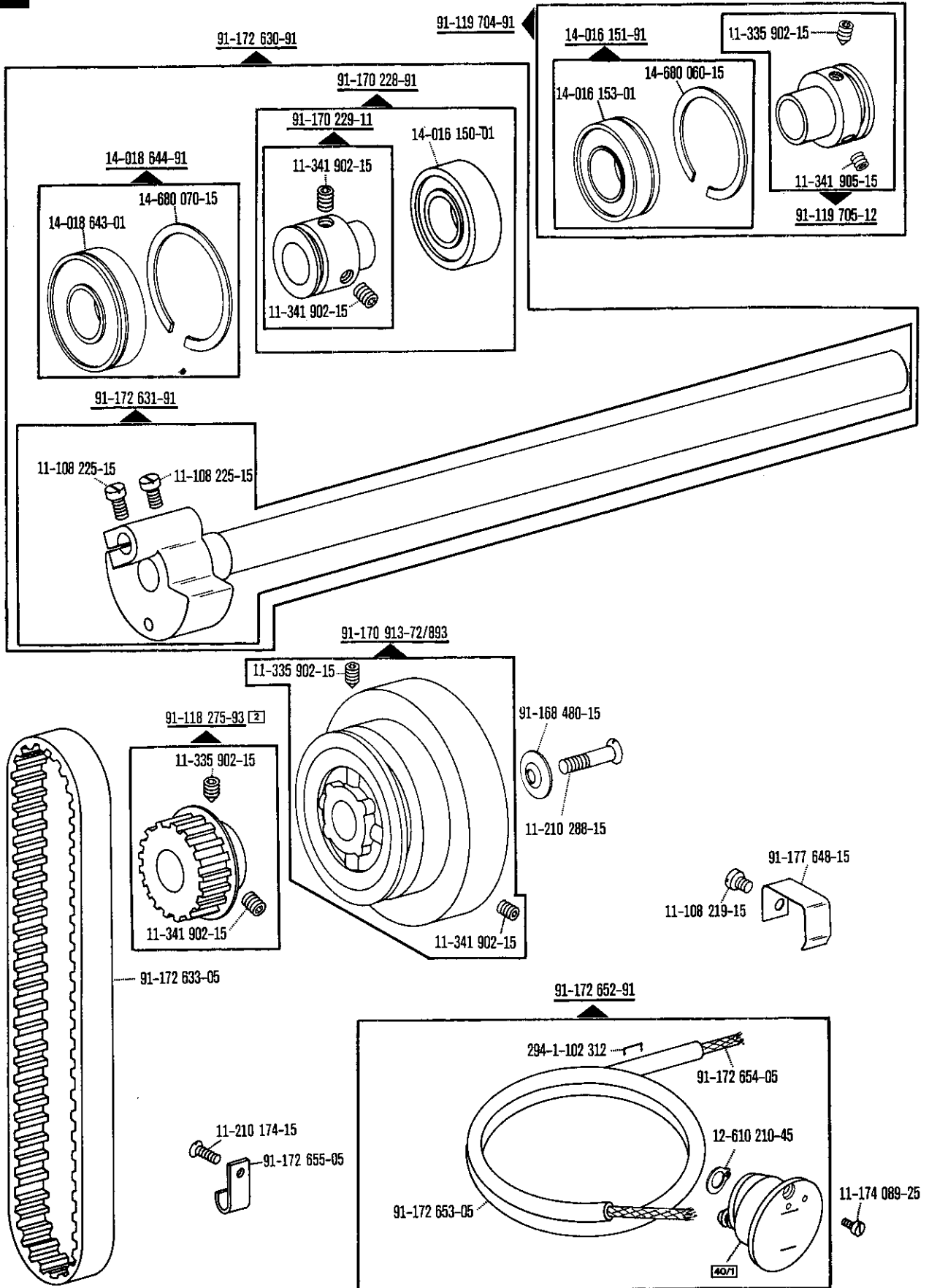

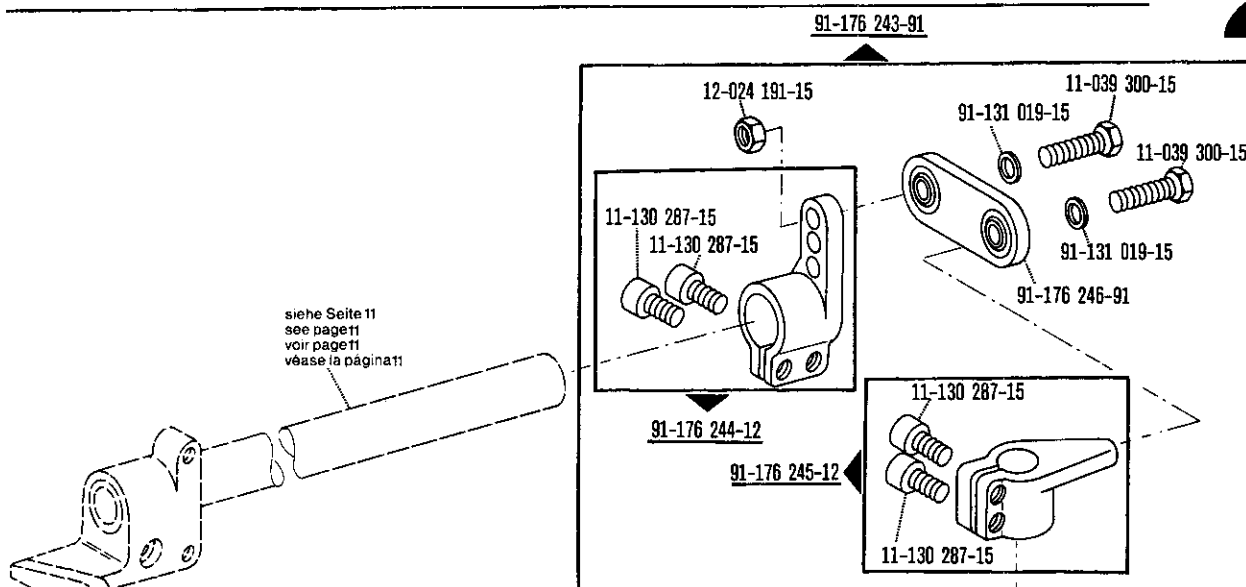

siehe Seite 11
see page 11
voir page 11
véase la página 11

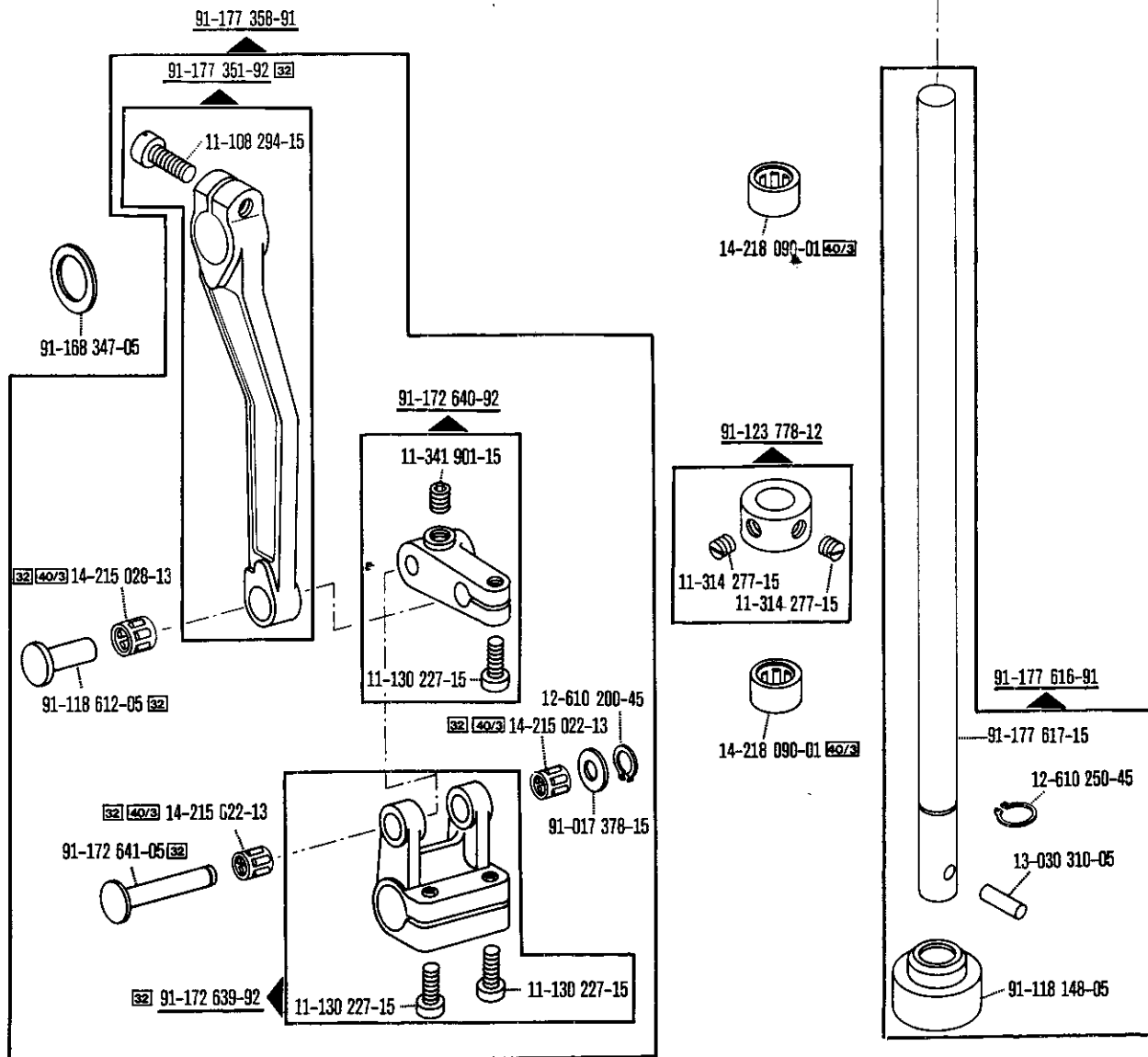

☐ siehe Erläuterungen Register O
see explanations in section O
voir légende registre O

2

Arm parts
Pièces de bras
Piezas del brazo PFAFF 5645 H-840/01-706/07

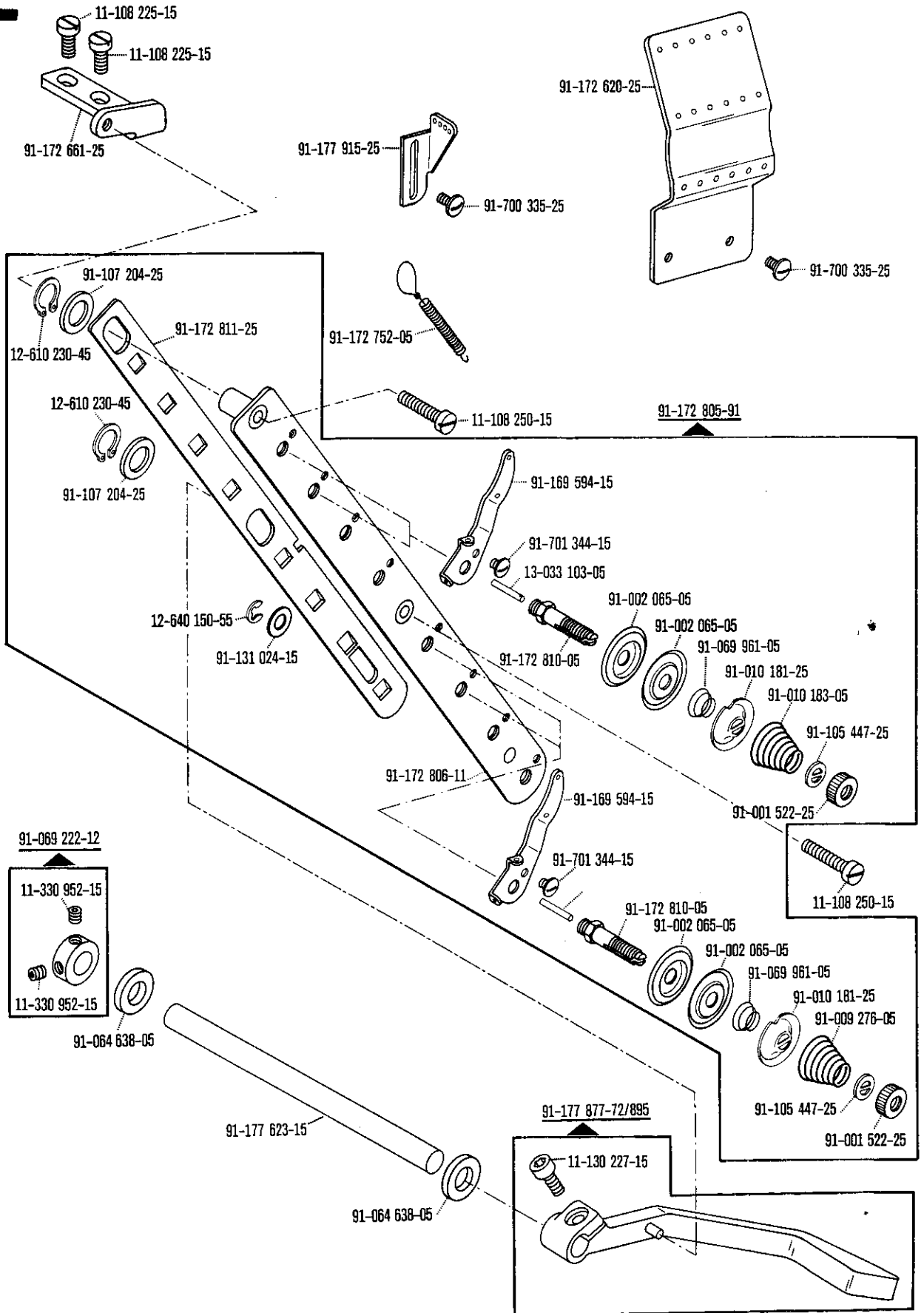

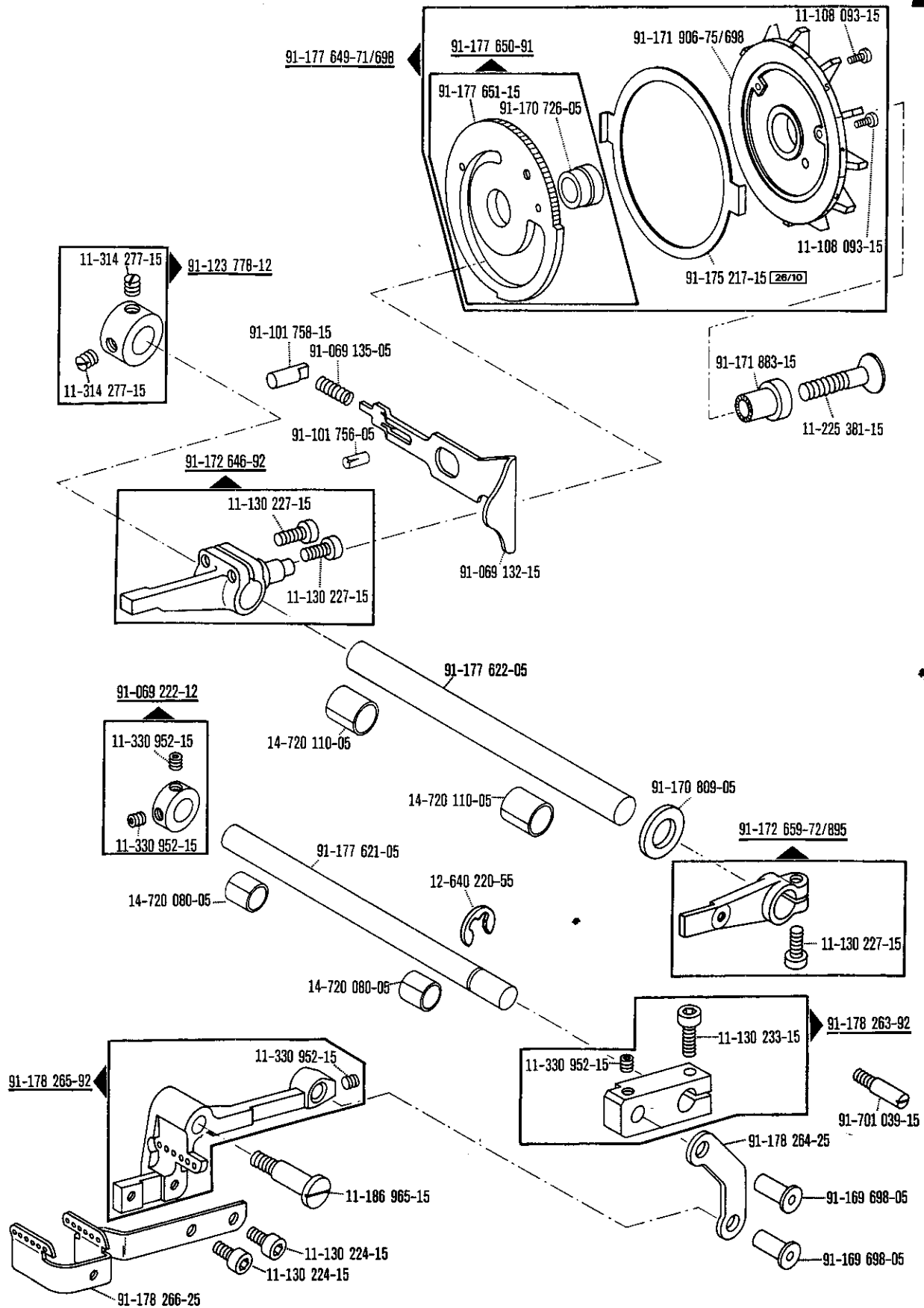

3

Bedplate parts Pièces du plateau fondamental Piezas de la placa-base

PFAFF 5645 H-840/01-706/07

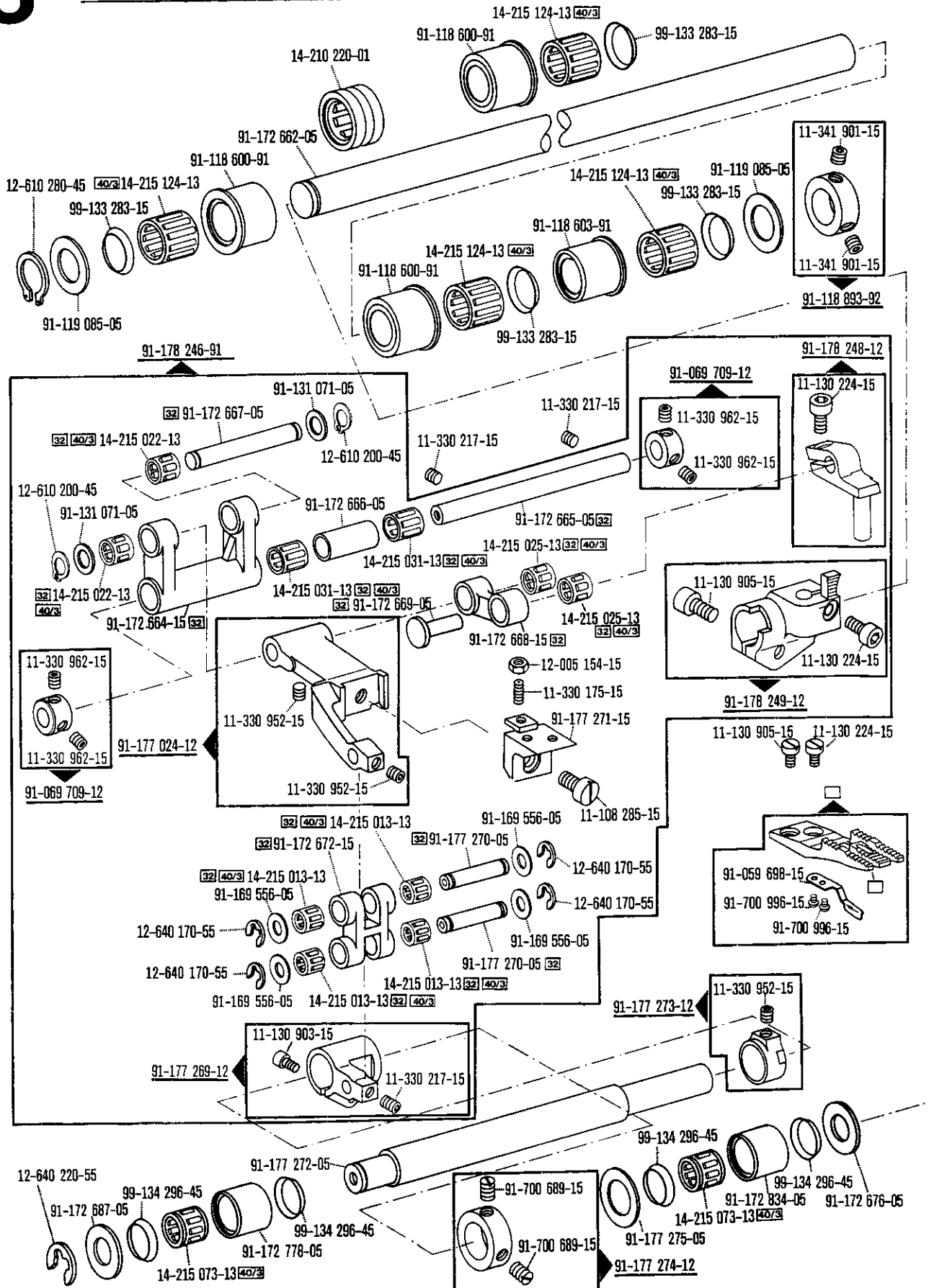

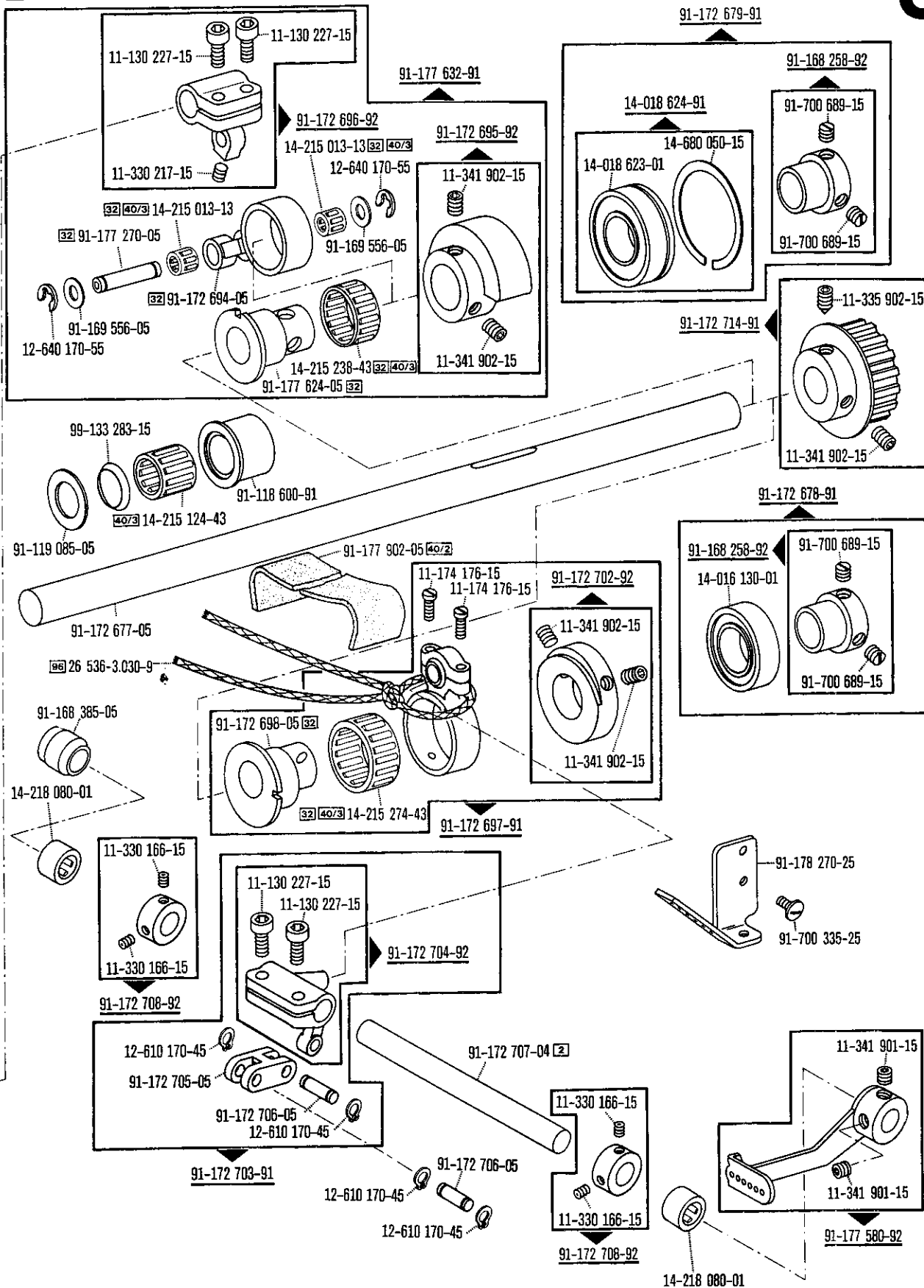

3

Separate parts
Pièces du plateau fondamental
Piezas de la placa-base

PFAFF 5645 H-840/01-706/07

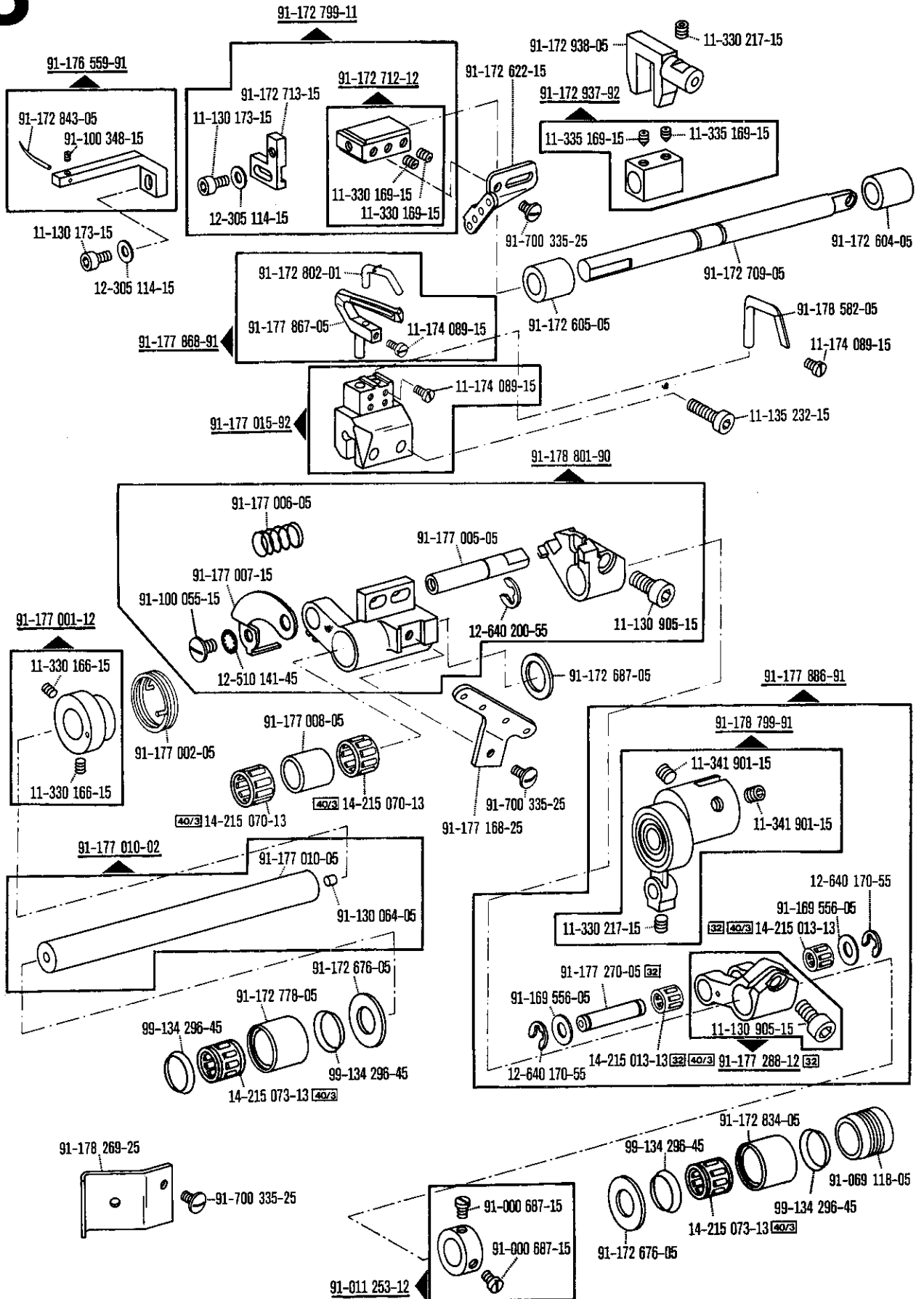

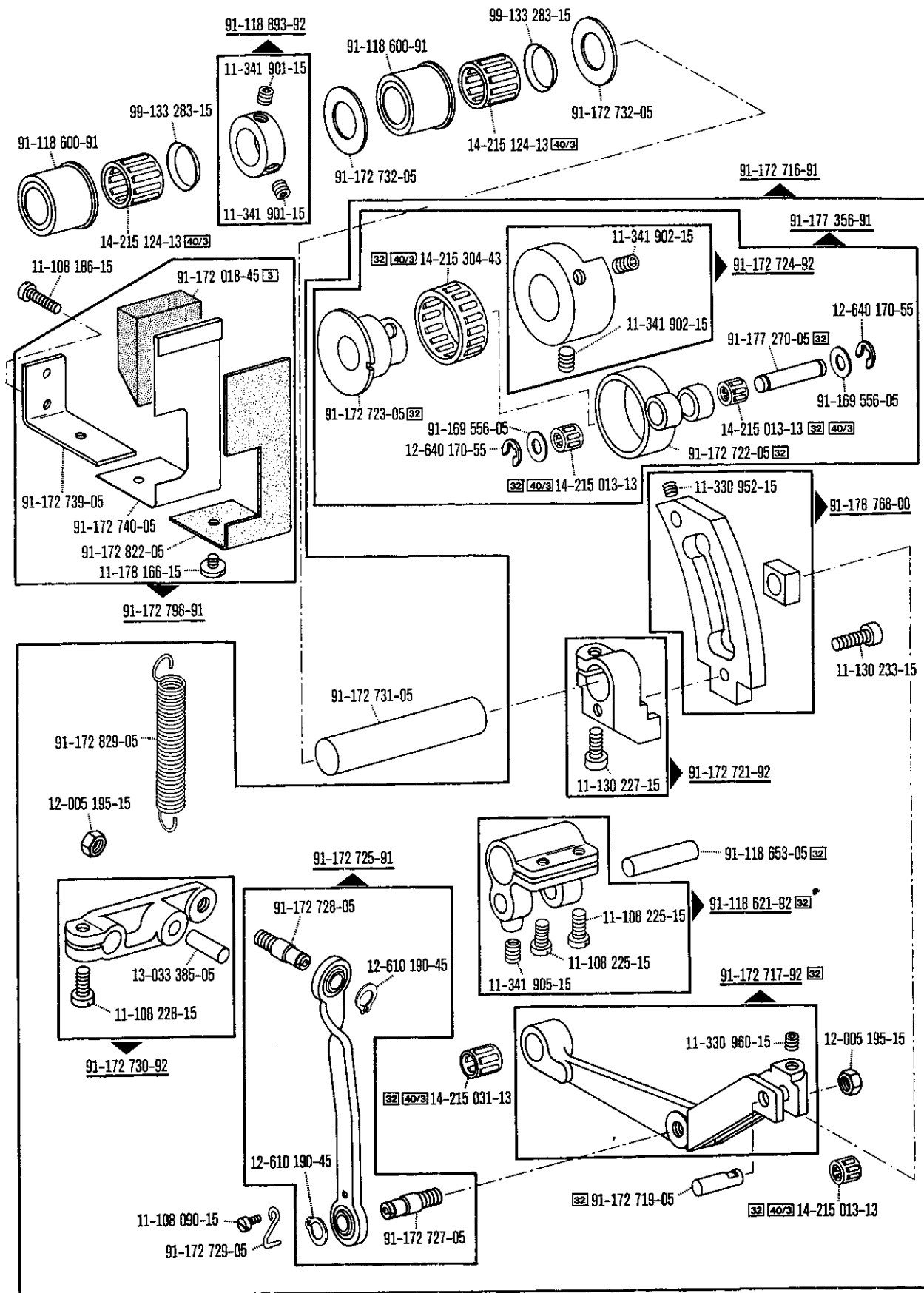

☐ siehe Erläuterungen Register O
 see explanations in section O
 voir légende registre O

4

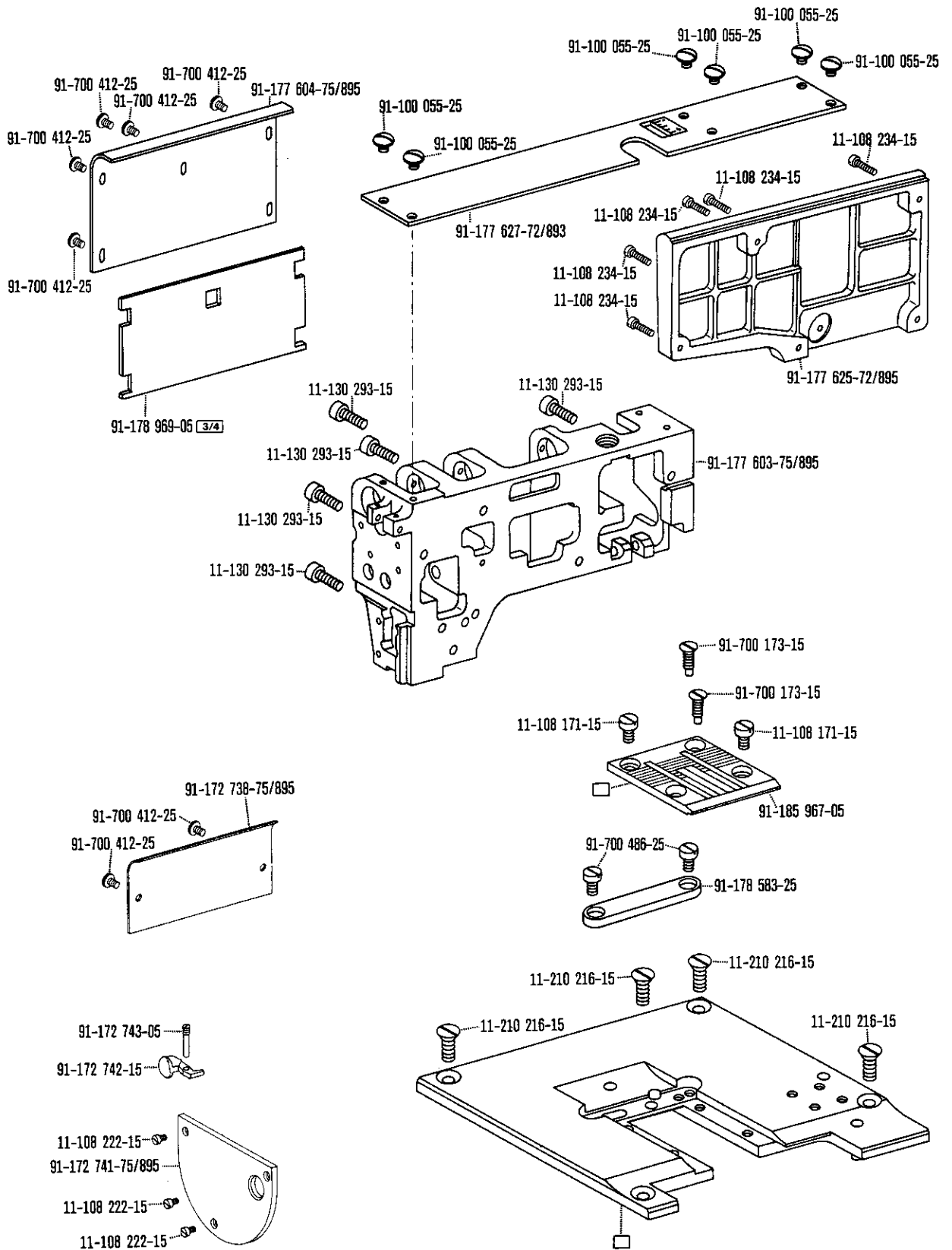

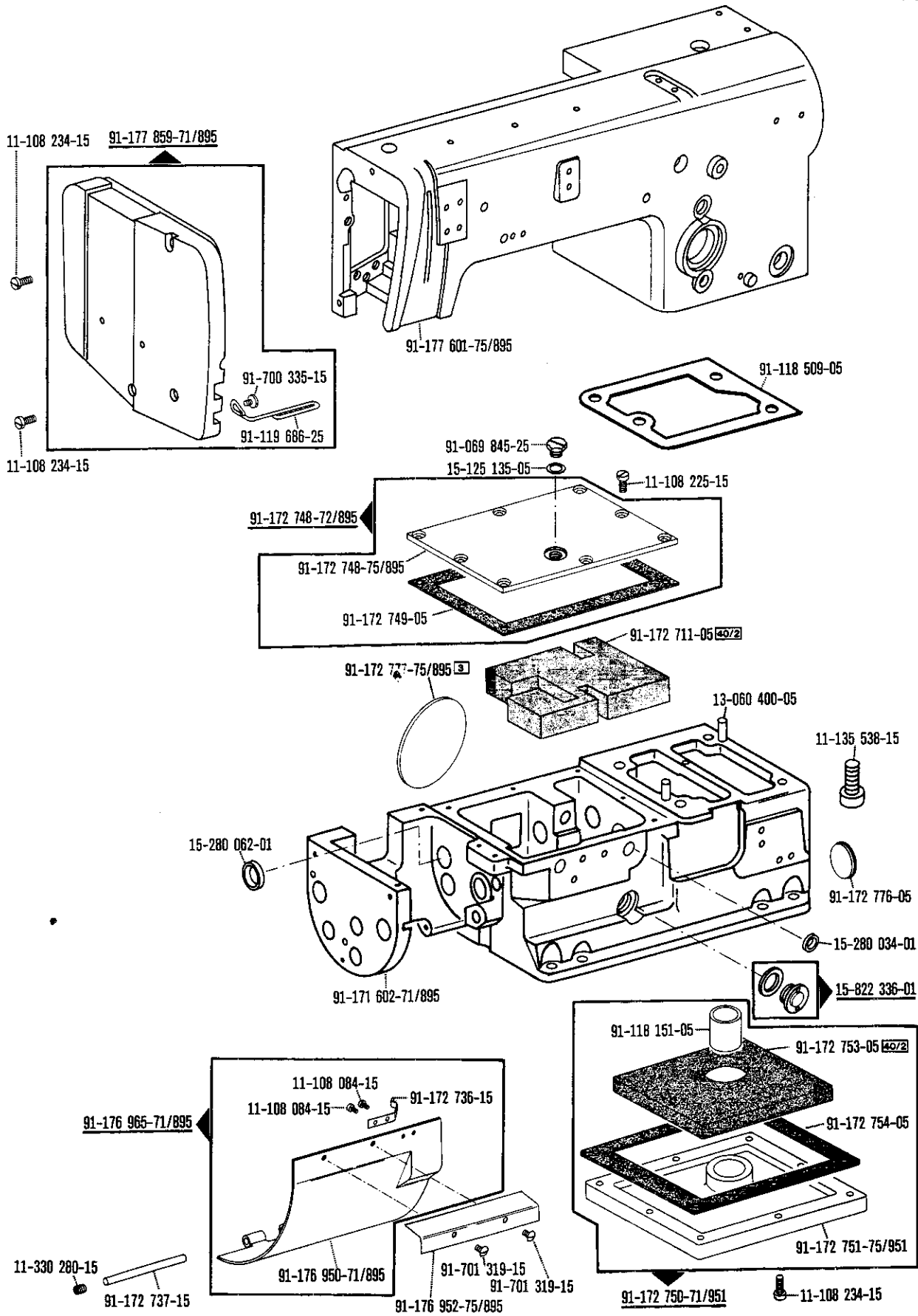

☐ siehe Erläuterungen Register O
 see explanations in section O
 voir légende registre O

4

Housing parts
Parties du corps
Piezas del cárter PFAFF 5645 H-840/01-706/07

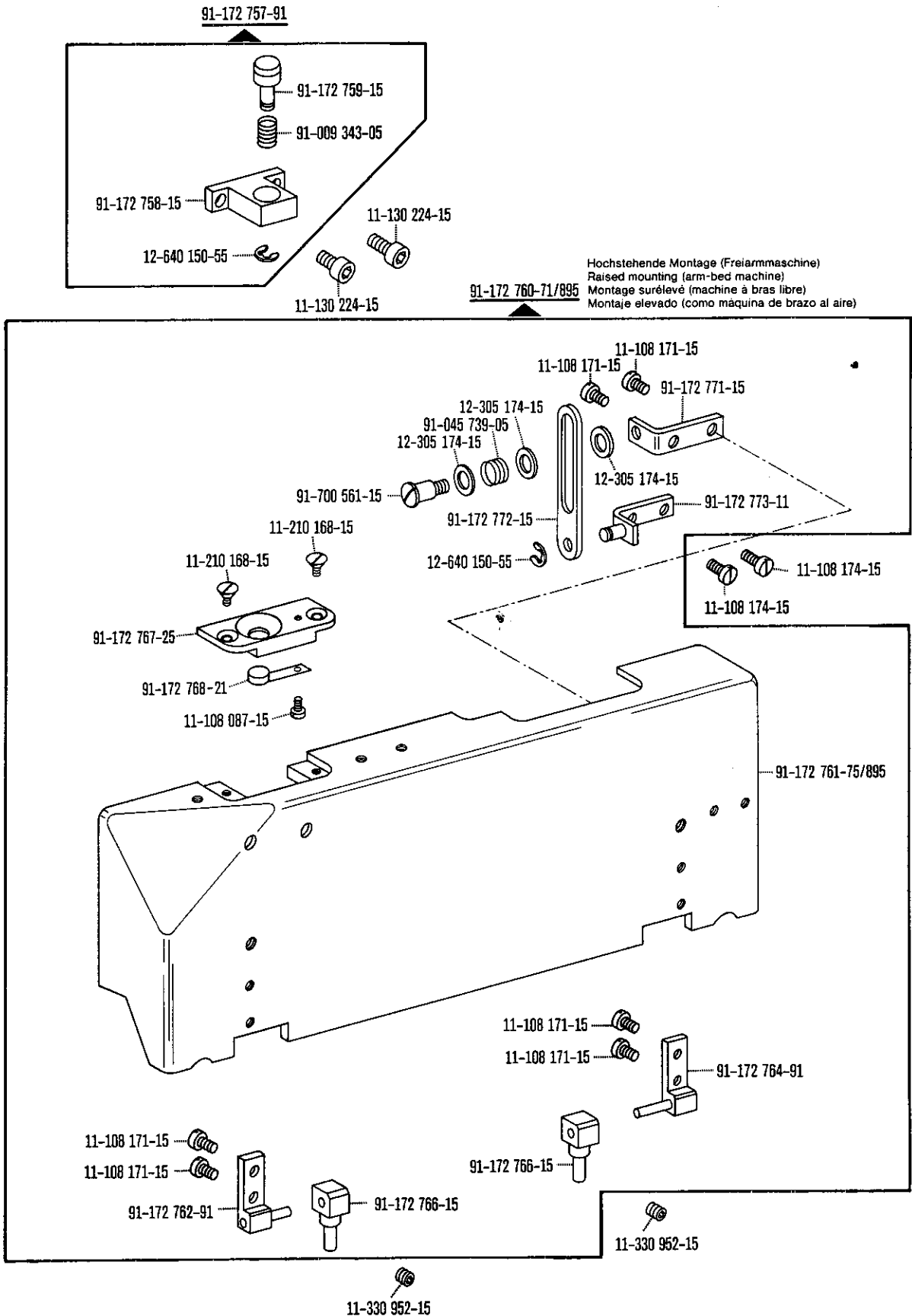

Tischebene Montage (Flachbettmaschine)
Flush mounting (Flatbed machine)
Montage en submergé (machine à plateau)
Montaje a ras del tablero (como máquina de base plana)

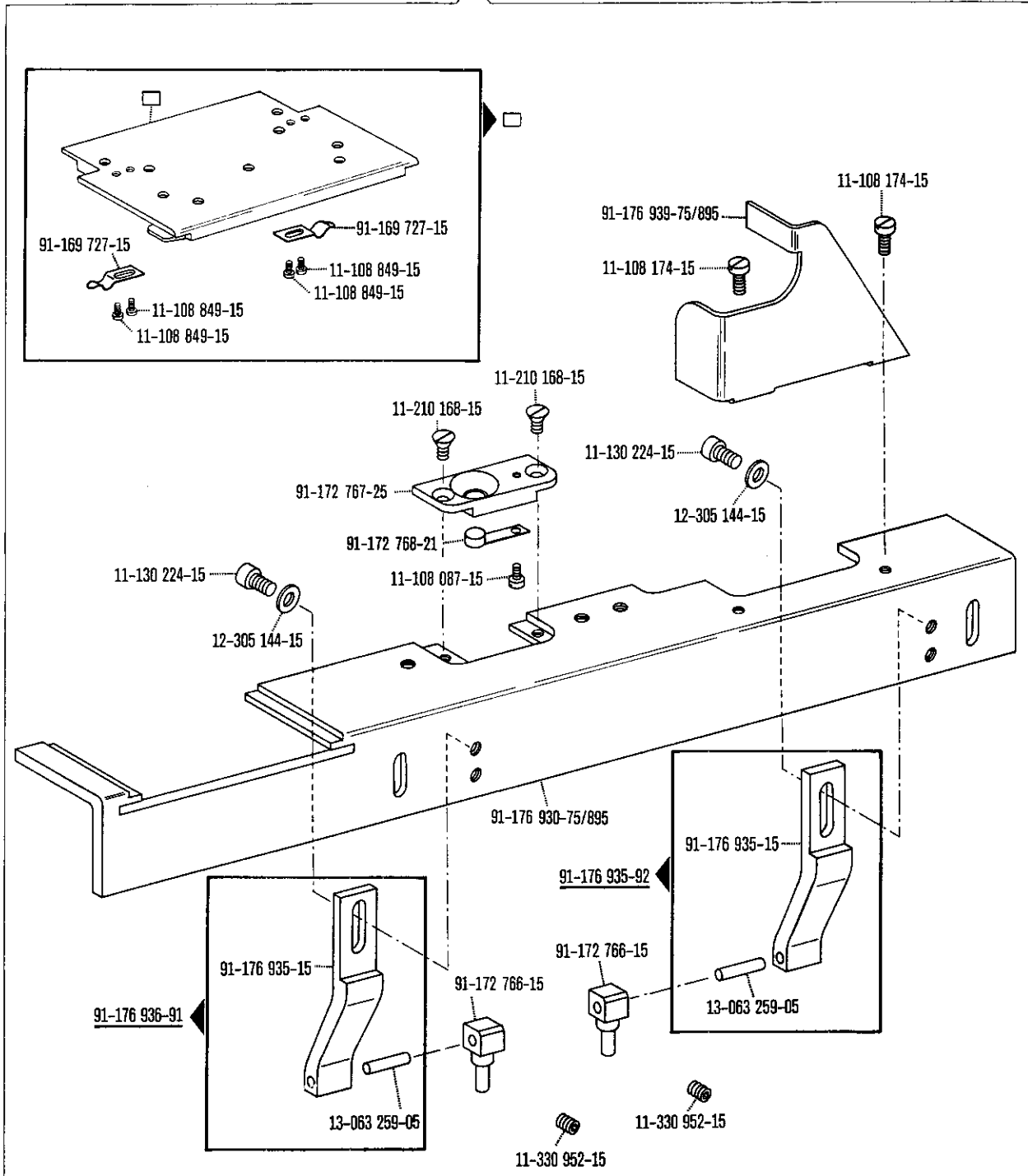

5

Complementary parts
Pièces complémentaires
Piezas especiales

PFAFF 5646 H-840/02-706/07

(les autres pièces comme dans le registre 1 – 4)
(las demás piezas como en el registro 1 – 4)

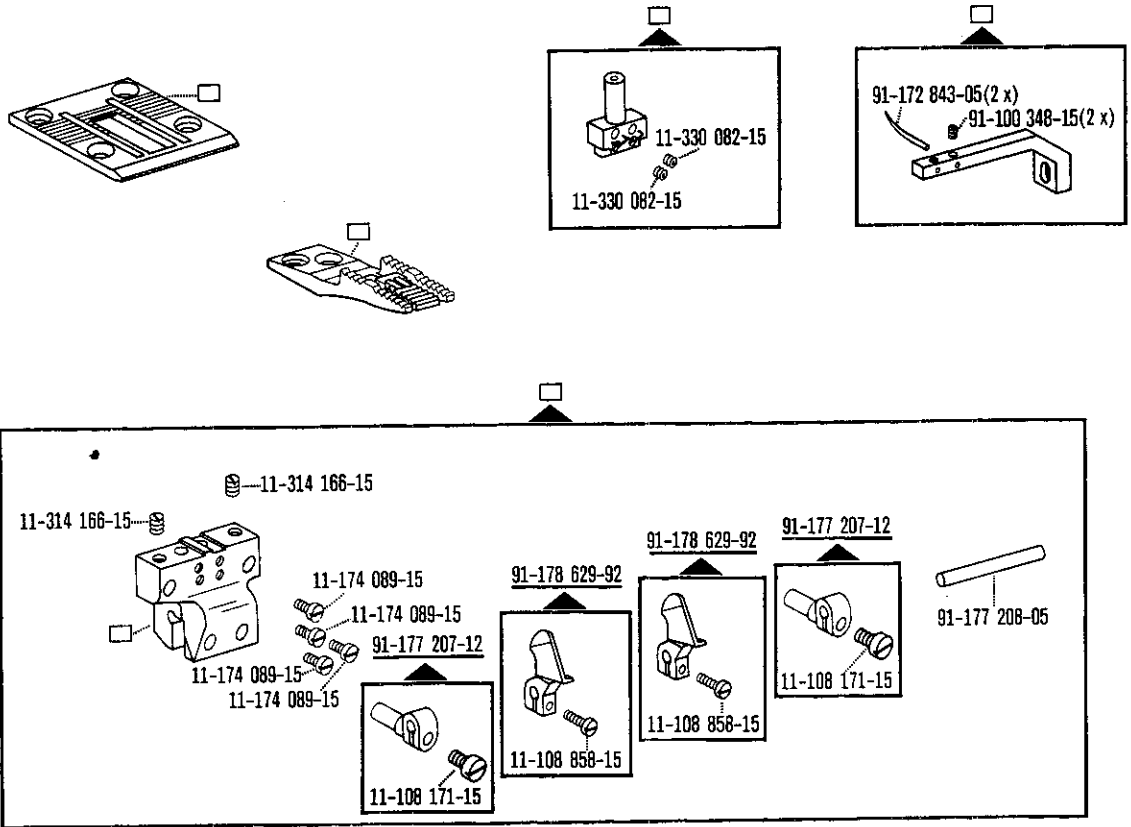

Ergänzungsteile
Complementary parts
Pièces complémentaires
Piezas especiales

PFAFF 5646 H-840/04-706/07

(die sonstigen Teile wie in Register 1 – 4)
(for all other parts see Section 1 – 4)
(les autres pièces comme dans le registre 1 – 4)
(las demás piezas como en el registro 1 – 4)

6

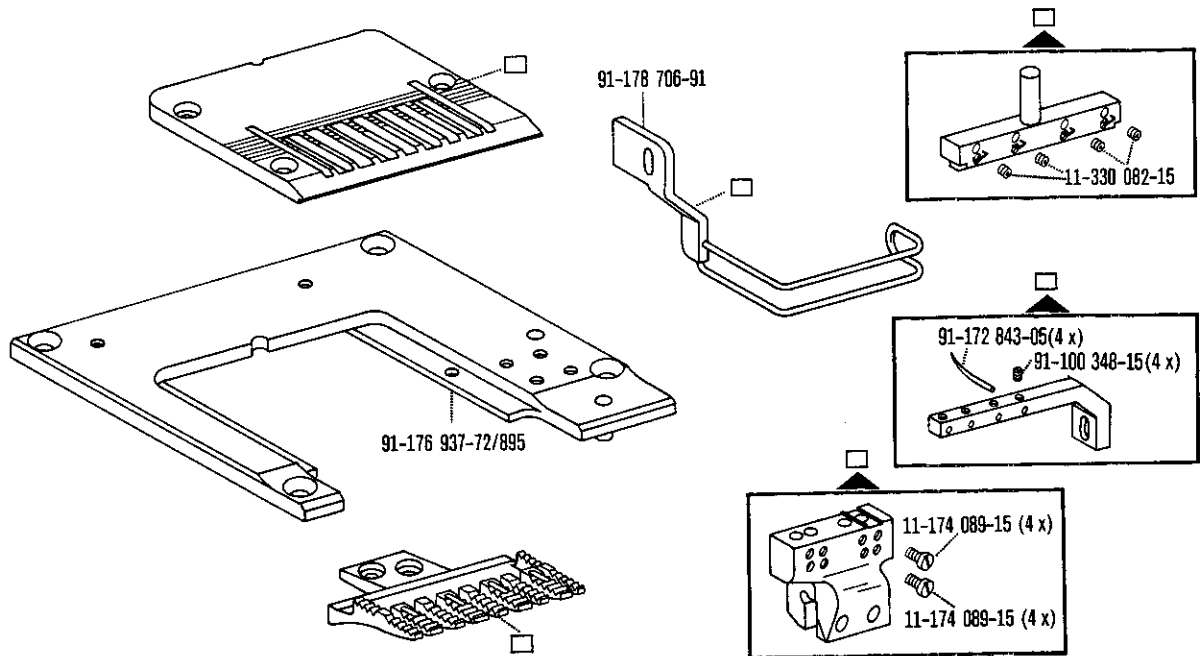

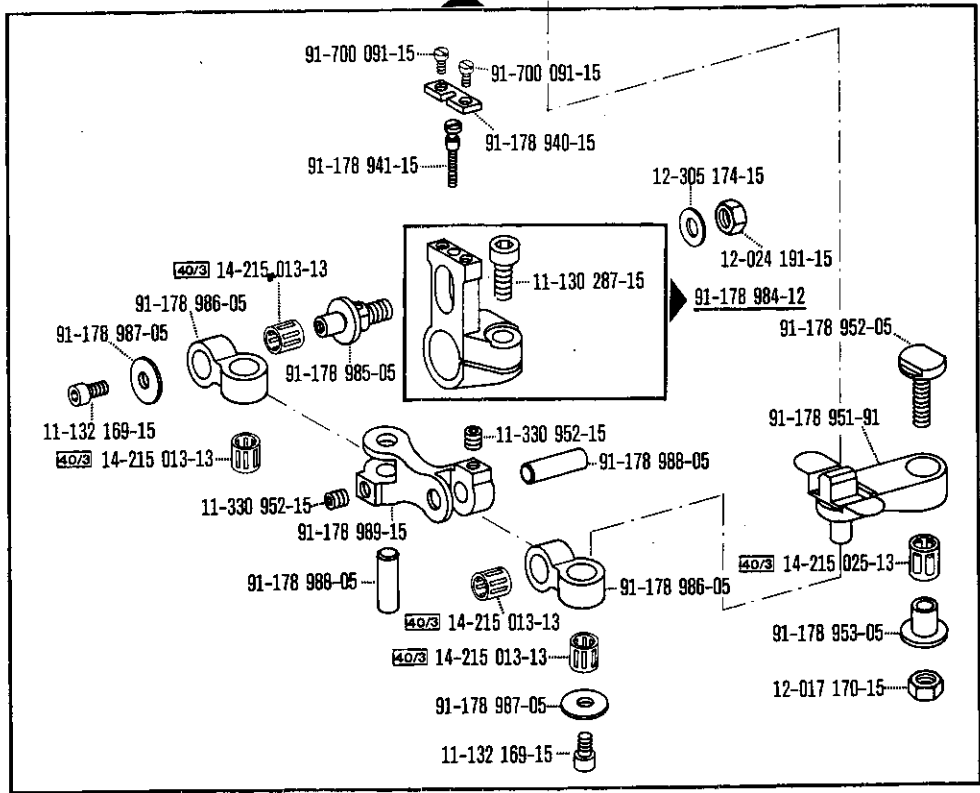
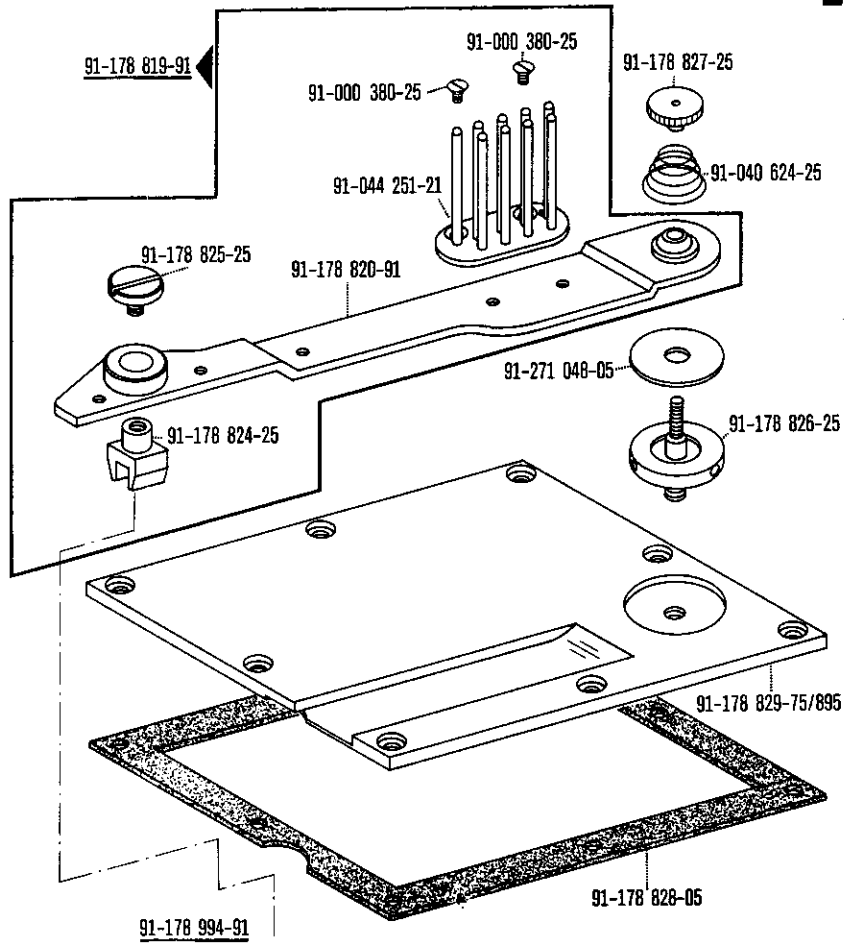

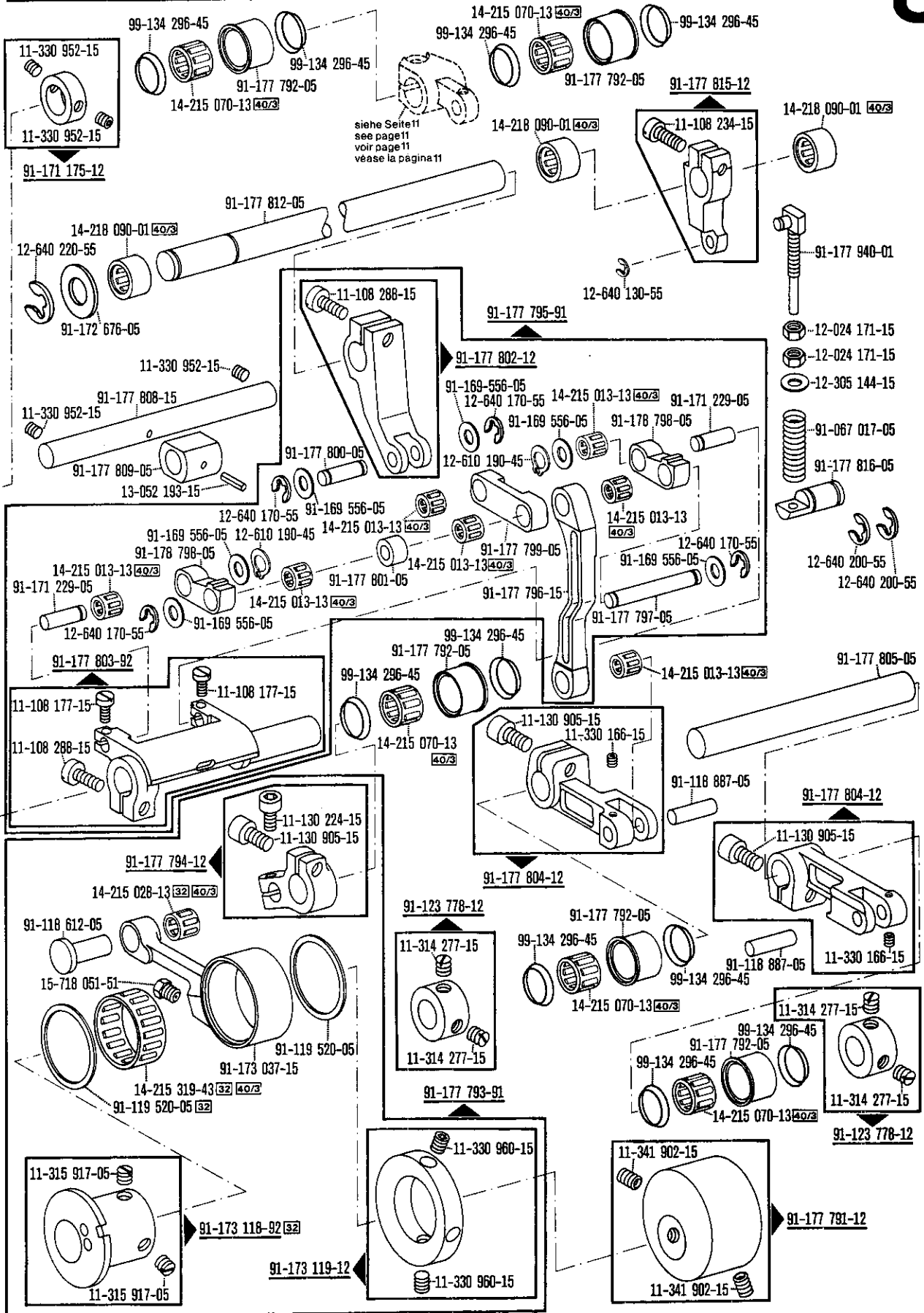

☐ siehe Erläuterungen Register O
 see explanations in section O
 voir légende registre O

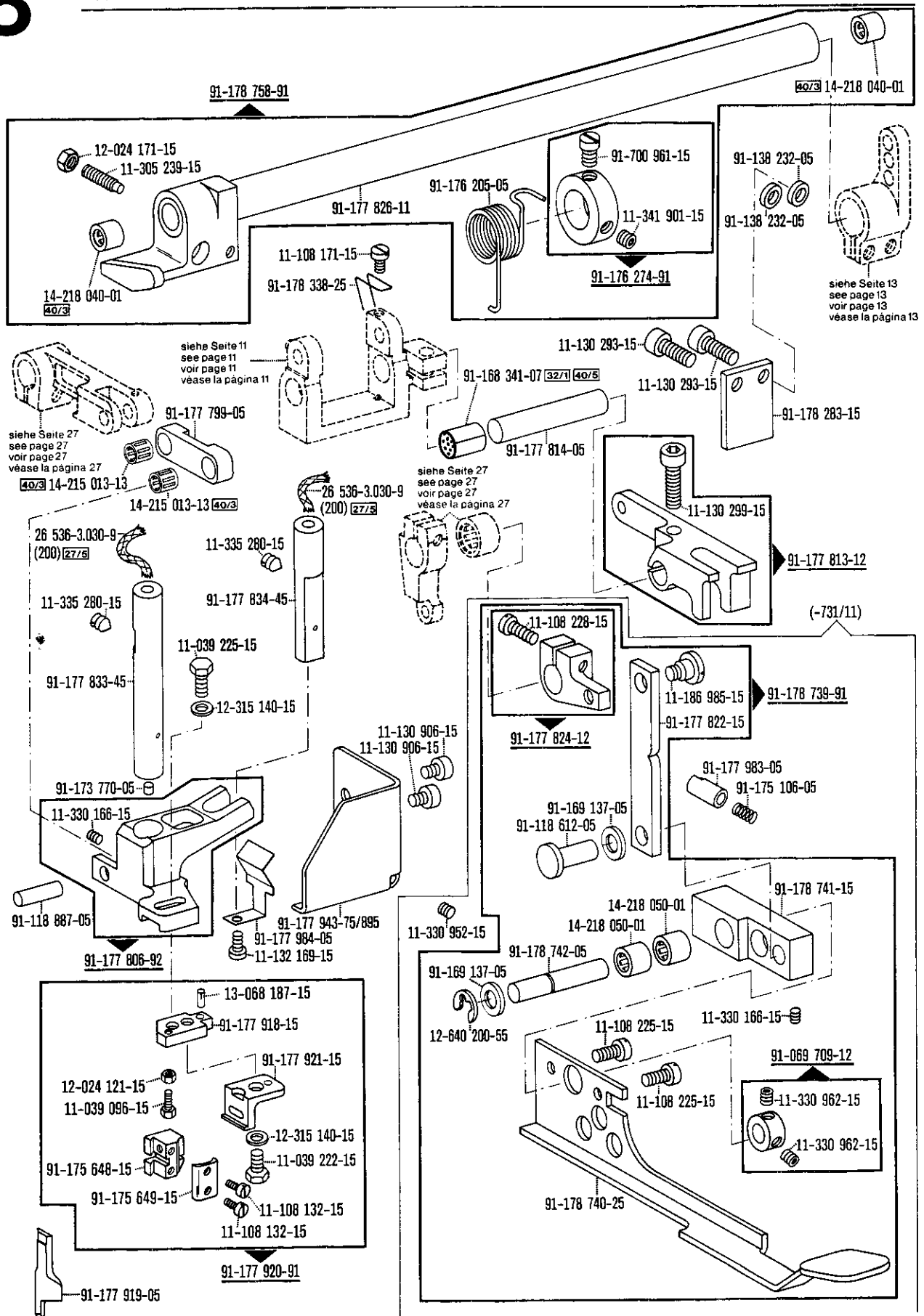

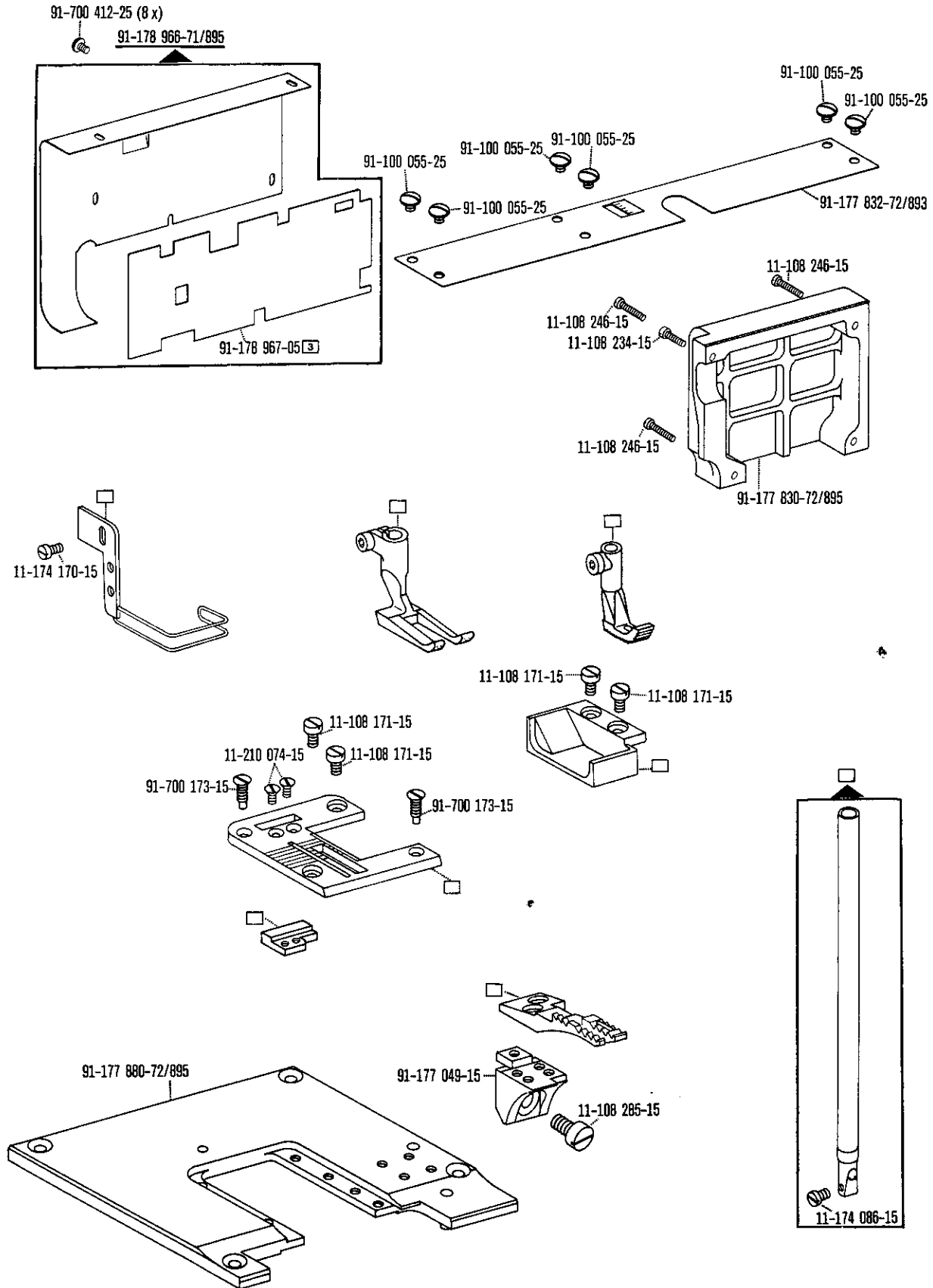

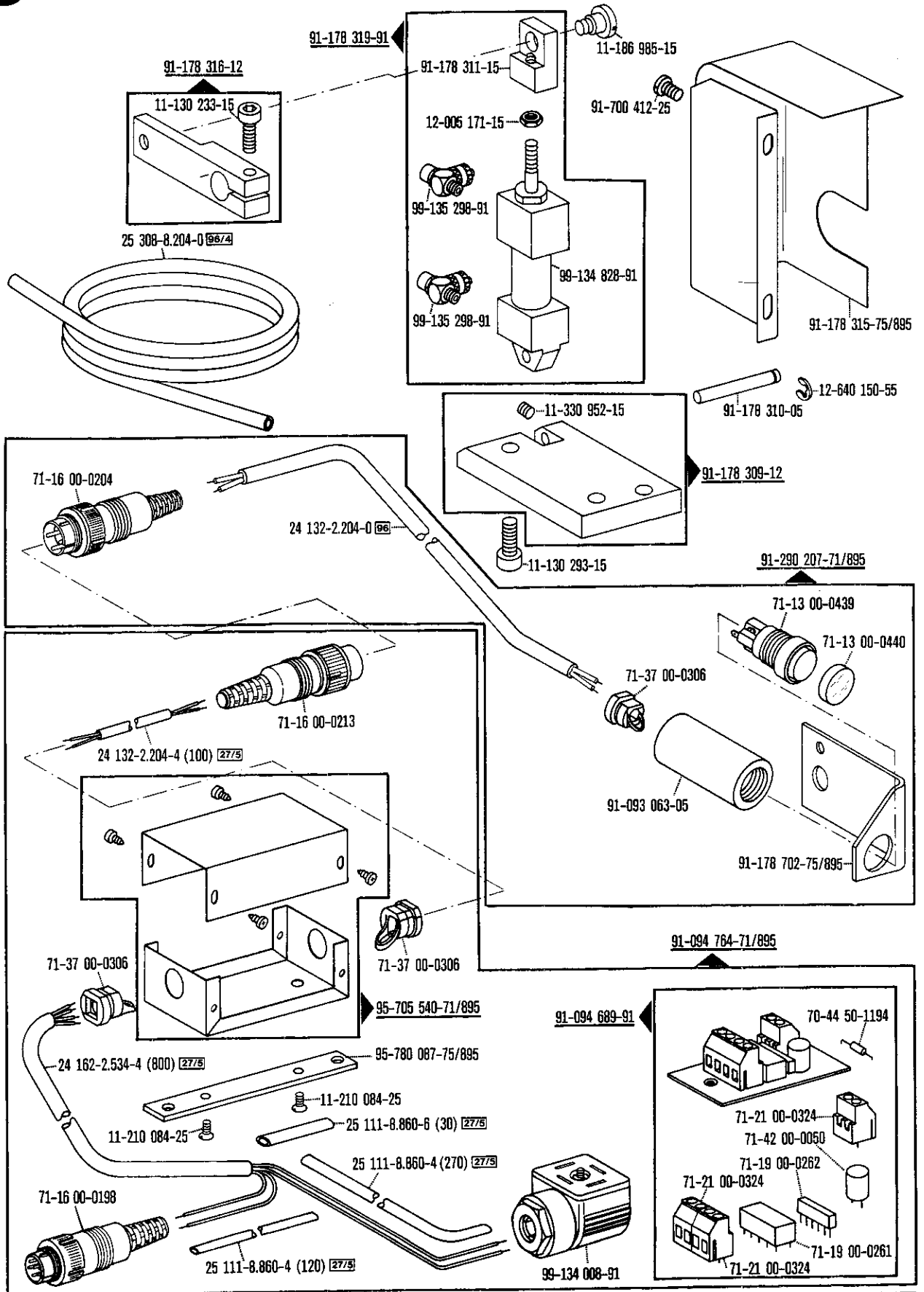

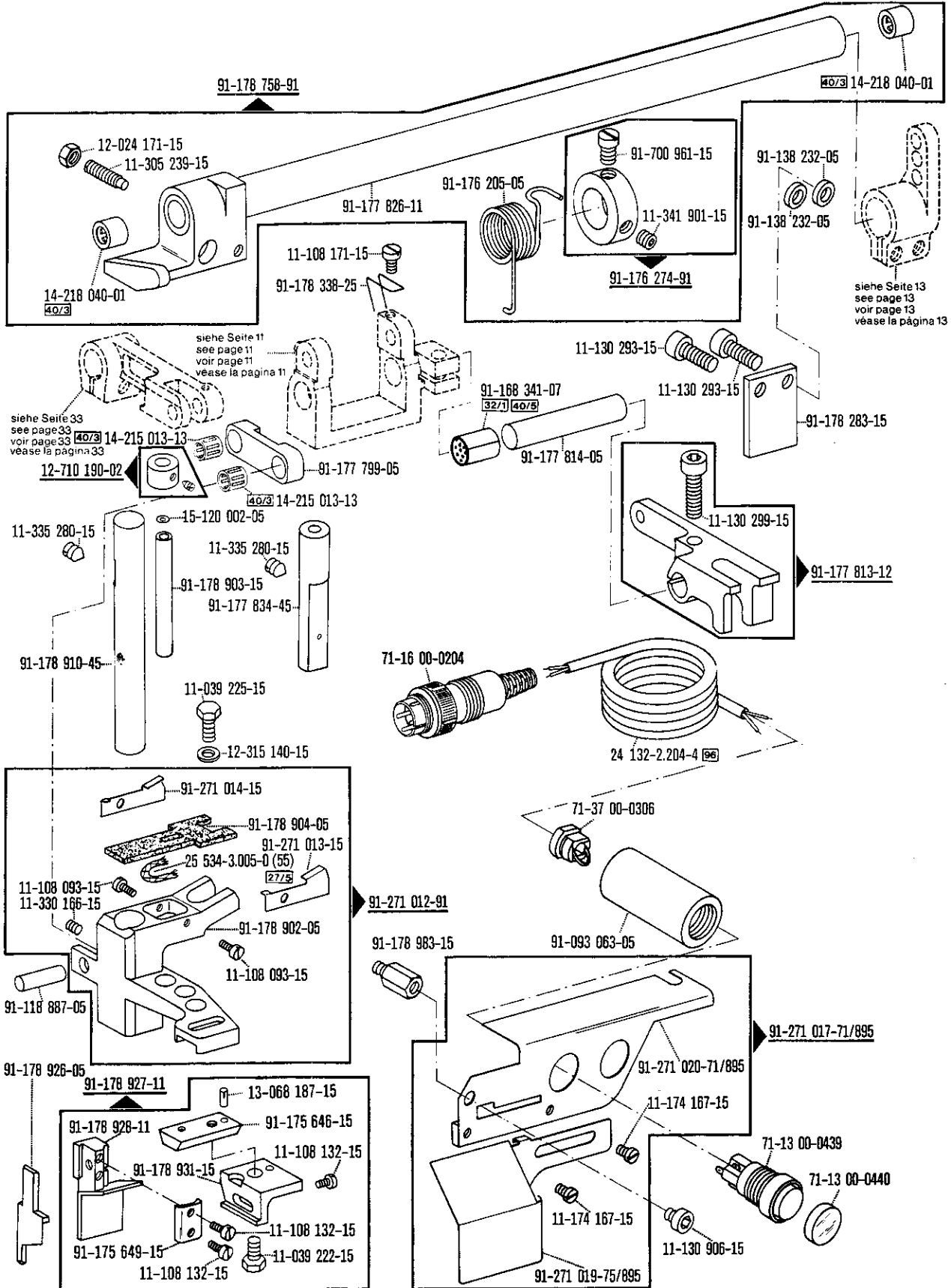

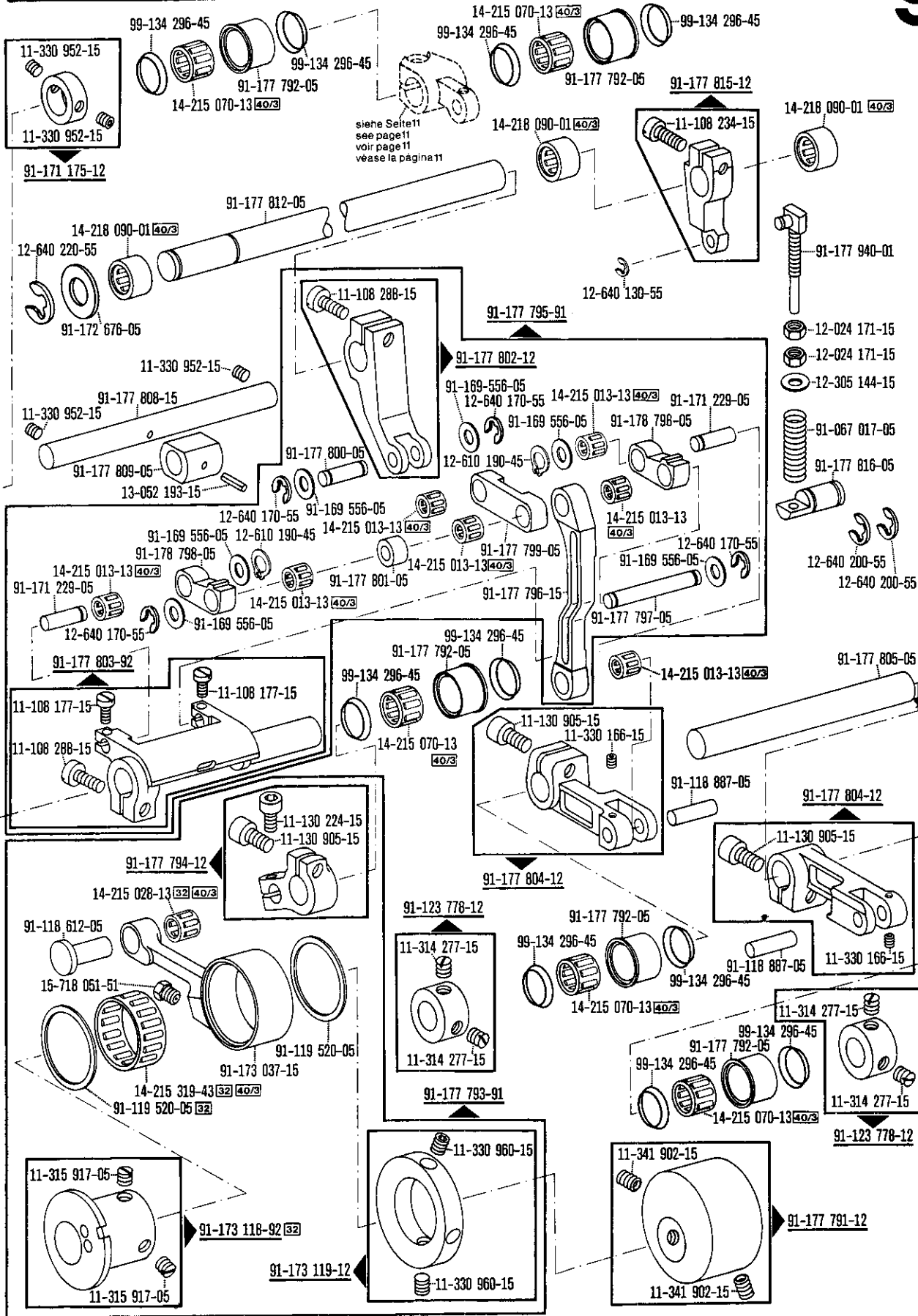

☐ siehe Erläuterungen Register O
 see explanations in section O
 voir légende registre O

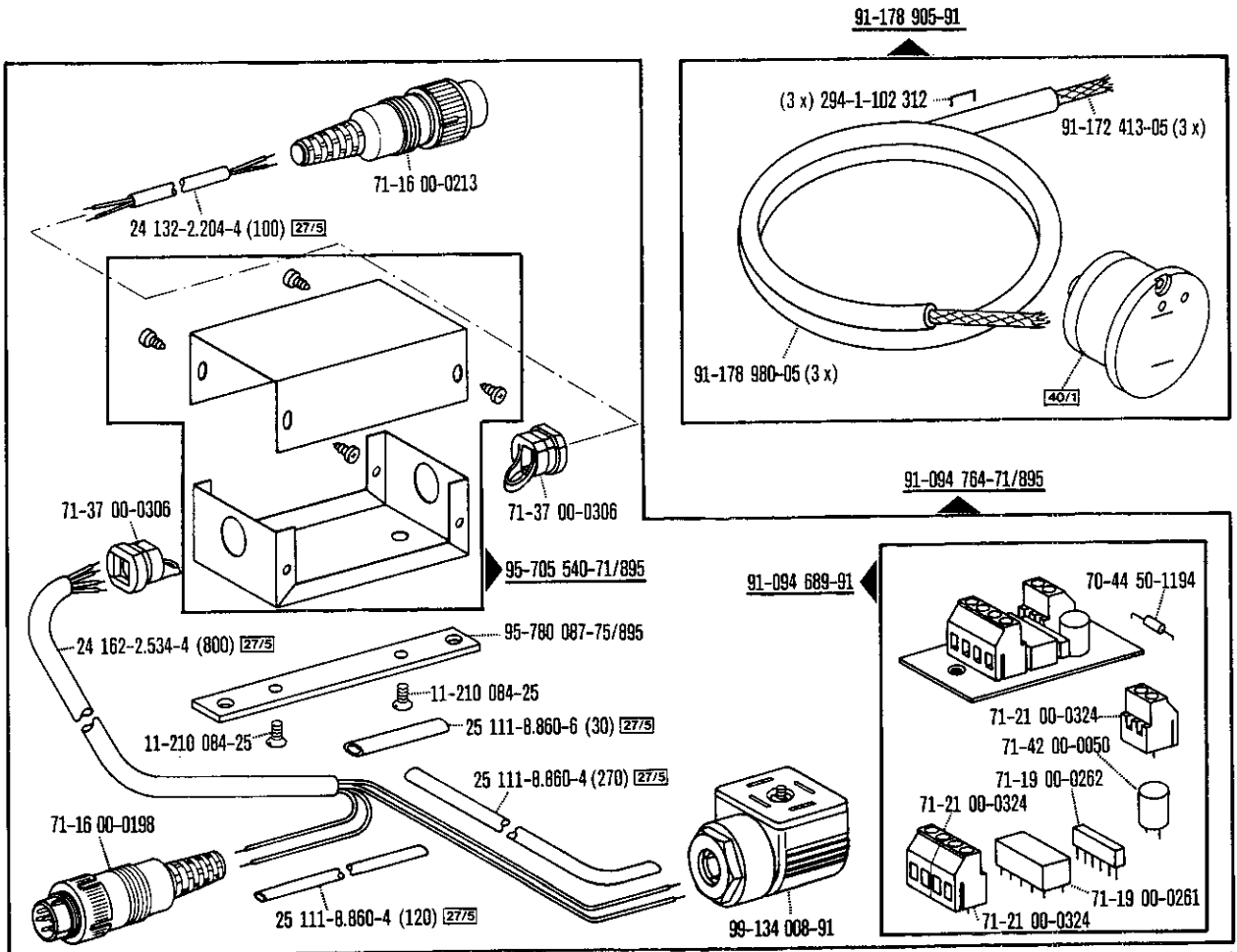
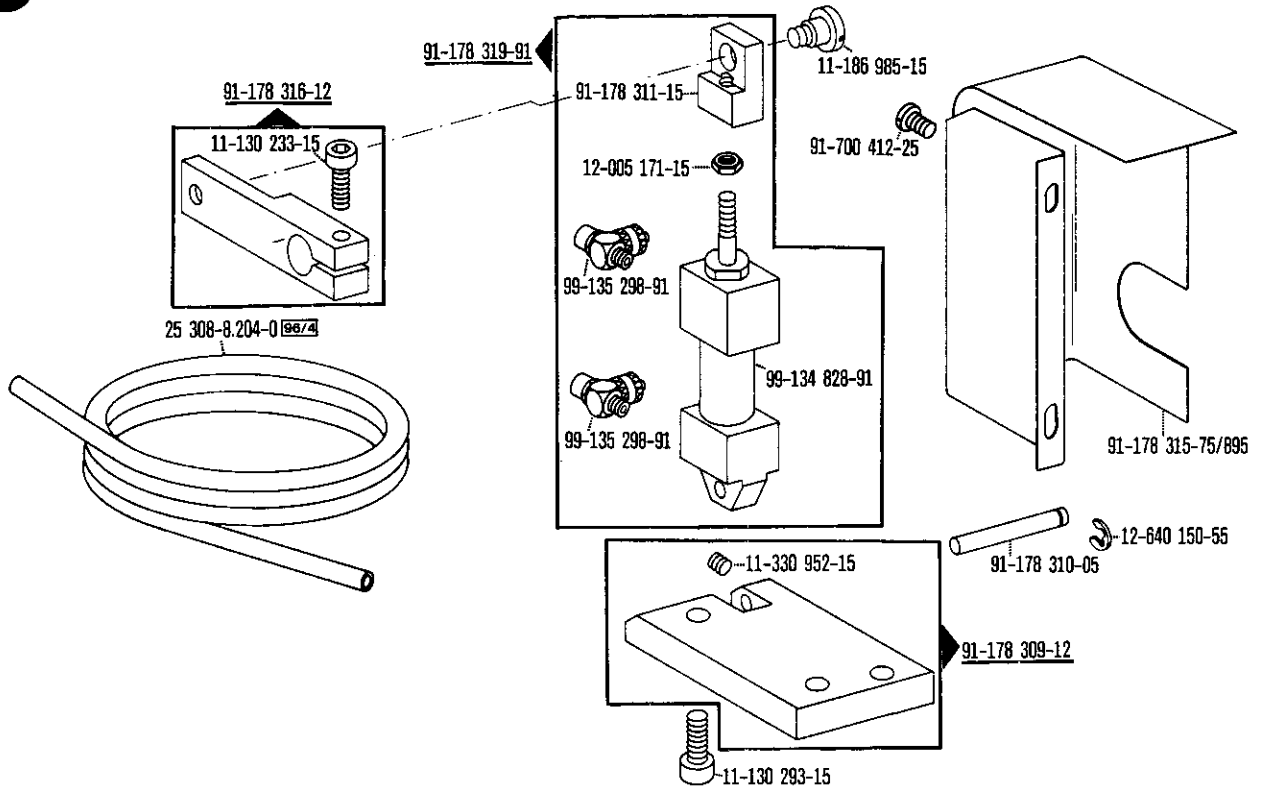

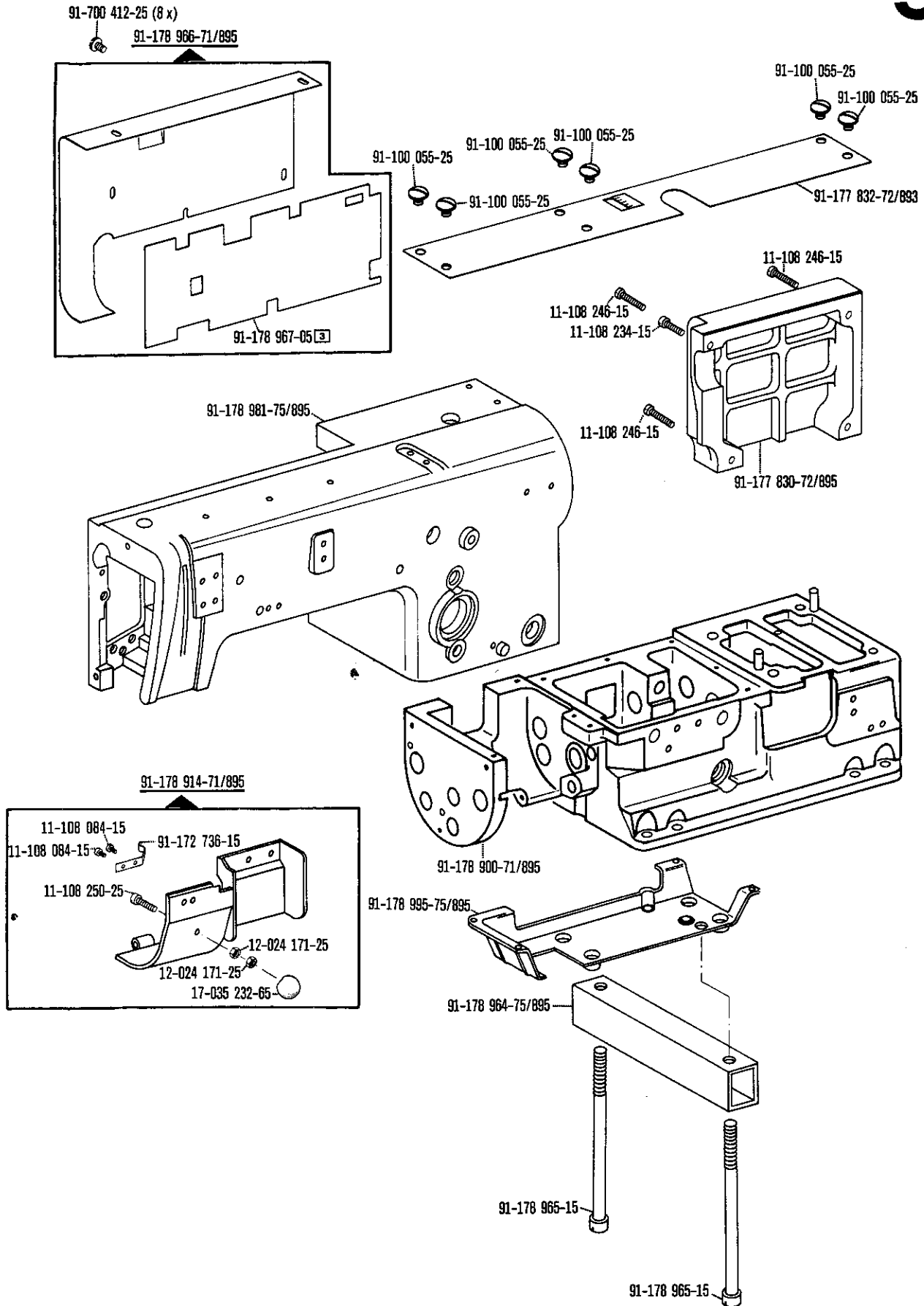

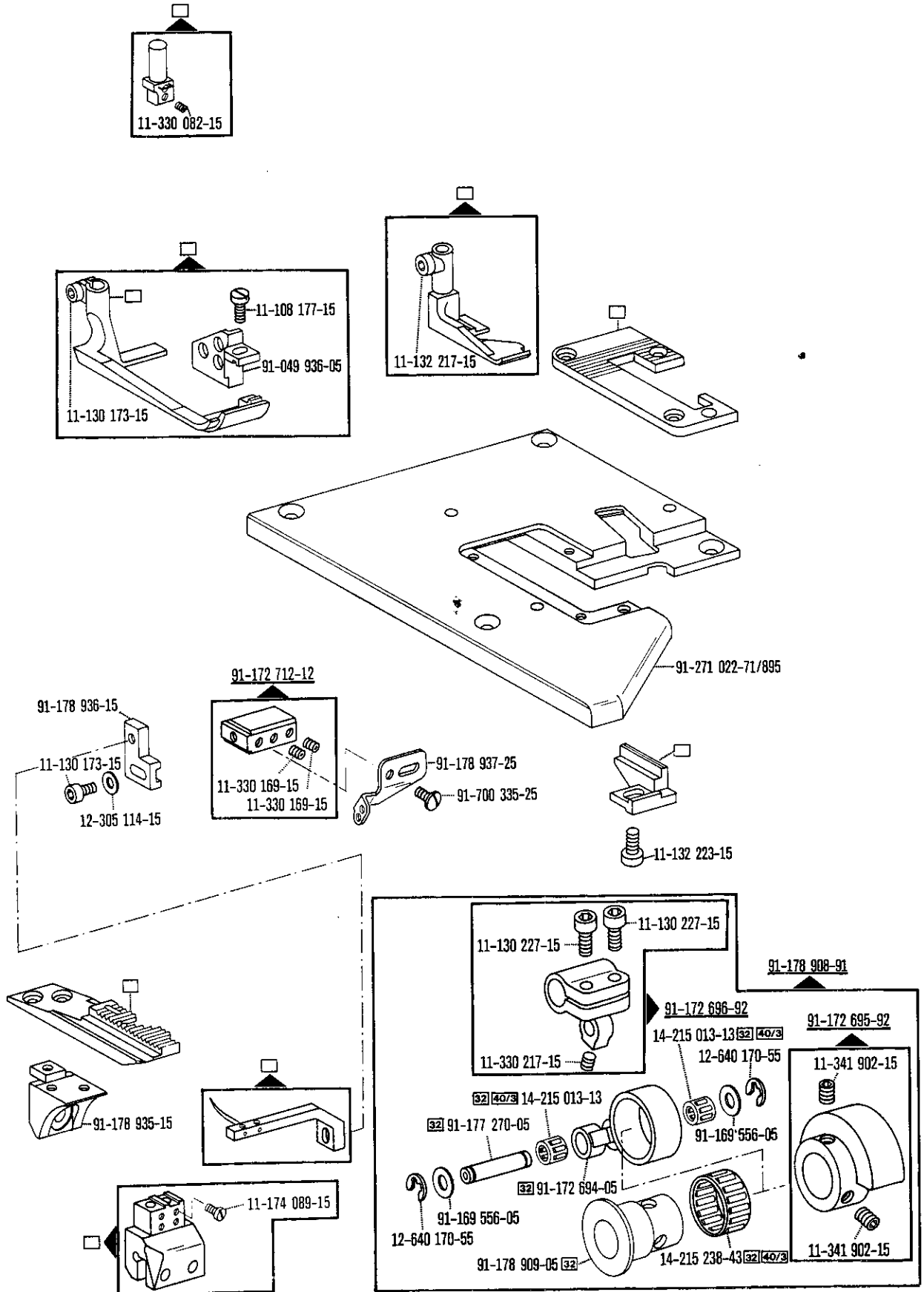

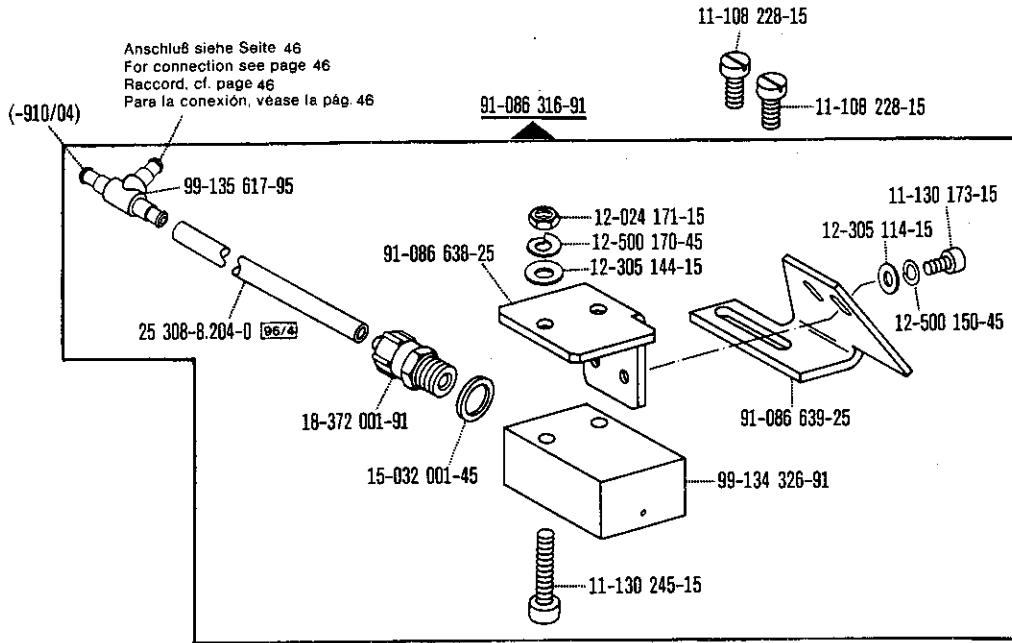

Presserfuß-Automatik
 Automatic presser foot lifter
 Relève-pied automatique
 Alzaprensateelas

-910/04

zur - pour
 for - para

PFAFF 5645 H; 5646 H

Wartungseinheit -925/02 erforderlich
 Conditioning unit -925/02 required
 Conditionneur d'air comprimé -925/02 nécessaire
 Requiere grupo acondicionador del aire compri-
 mido -925/02

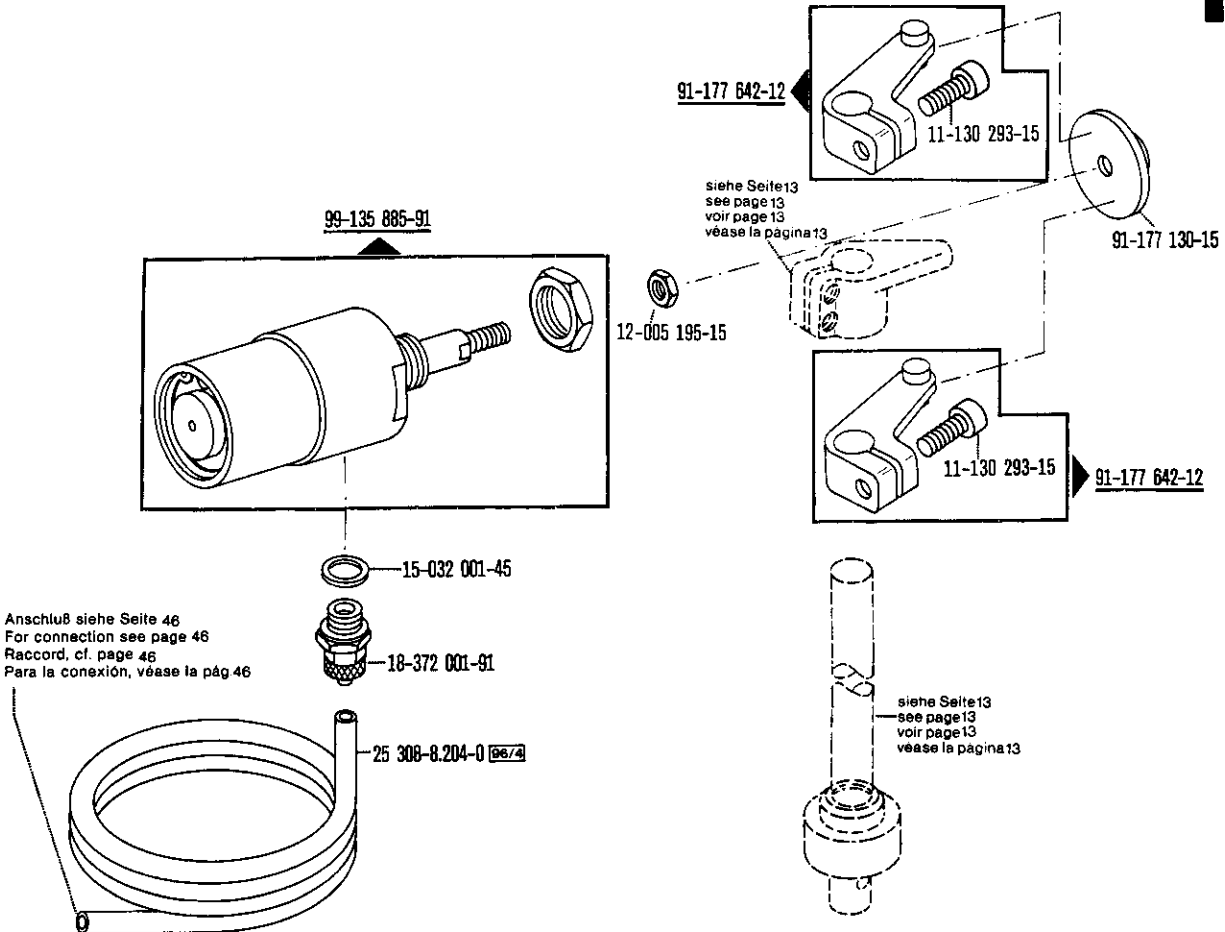

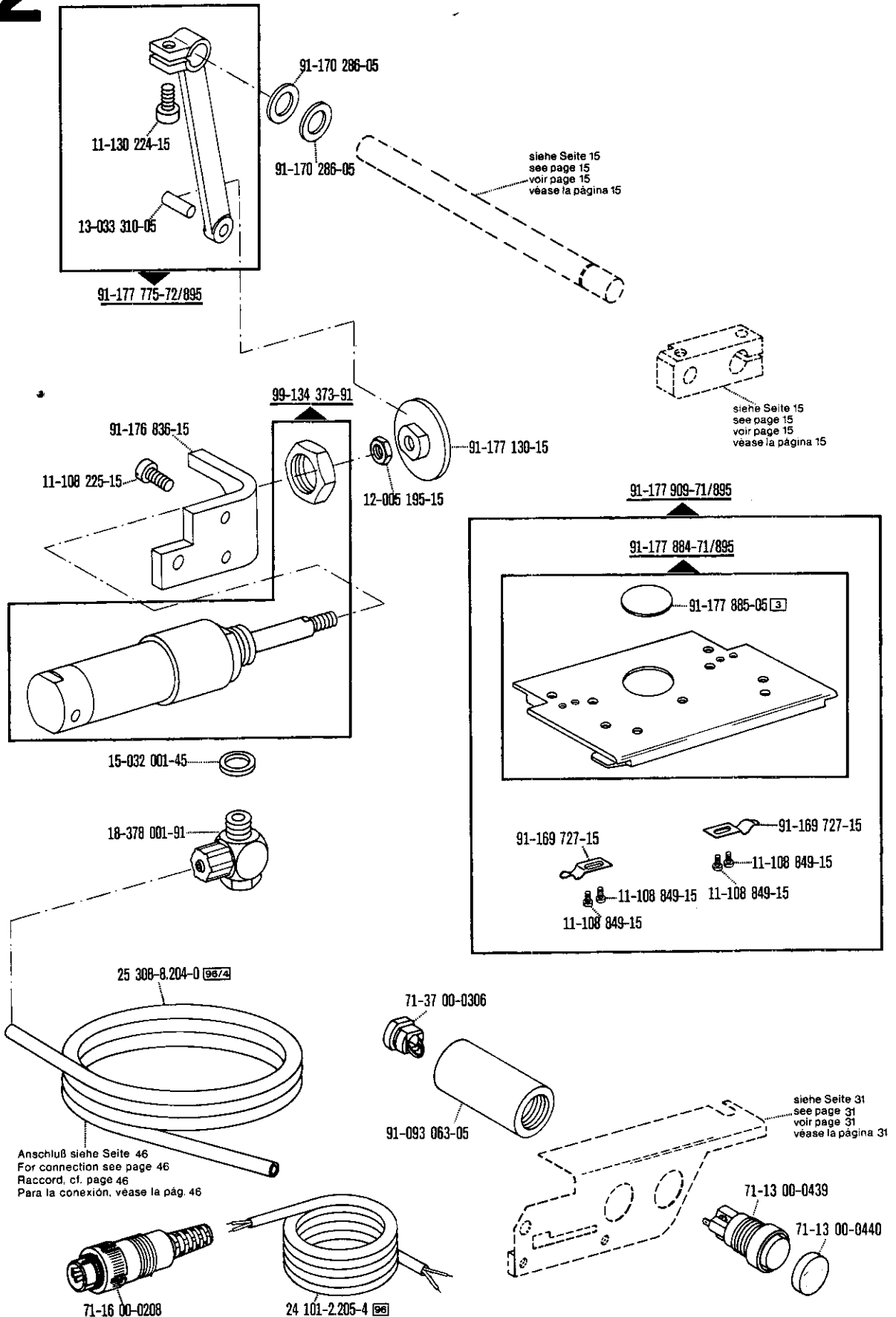

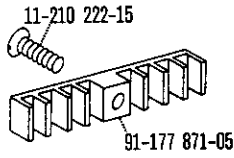

Anschluß siehe Seite 47
 For connection see page 47
 Raccord. cf. page 47
 Para la conexión, véase la pág. 47

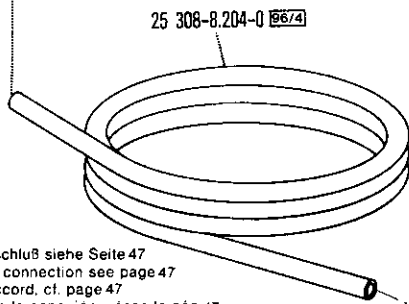

Anschluß siehe Seite 47
 For connection see page 47
 Raccord. cf. page 47
 Para la conexión, véase la pág. 47

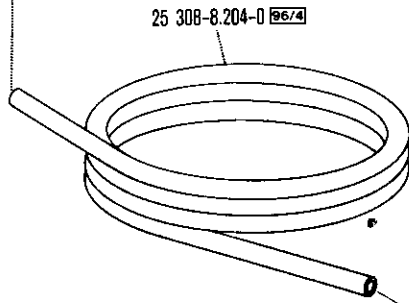

siehe Seite 11
 see page 11
 voir page 11
 véase la página 11

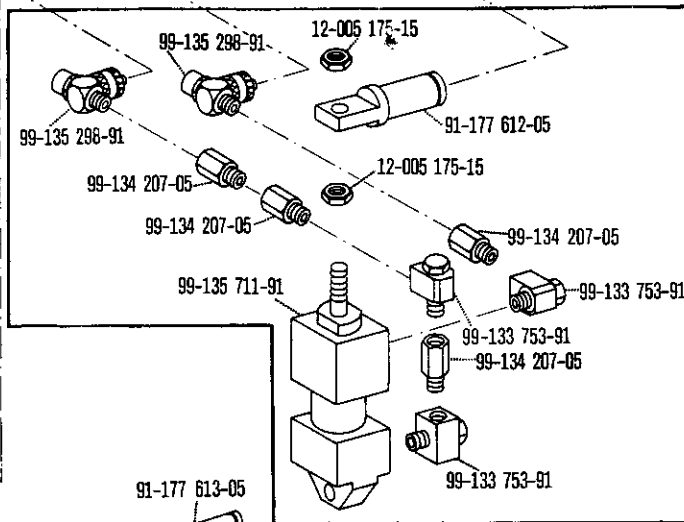
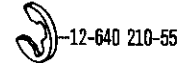
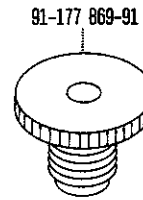

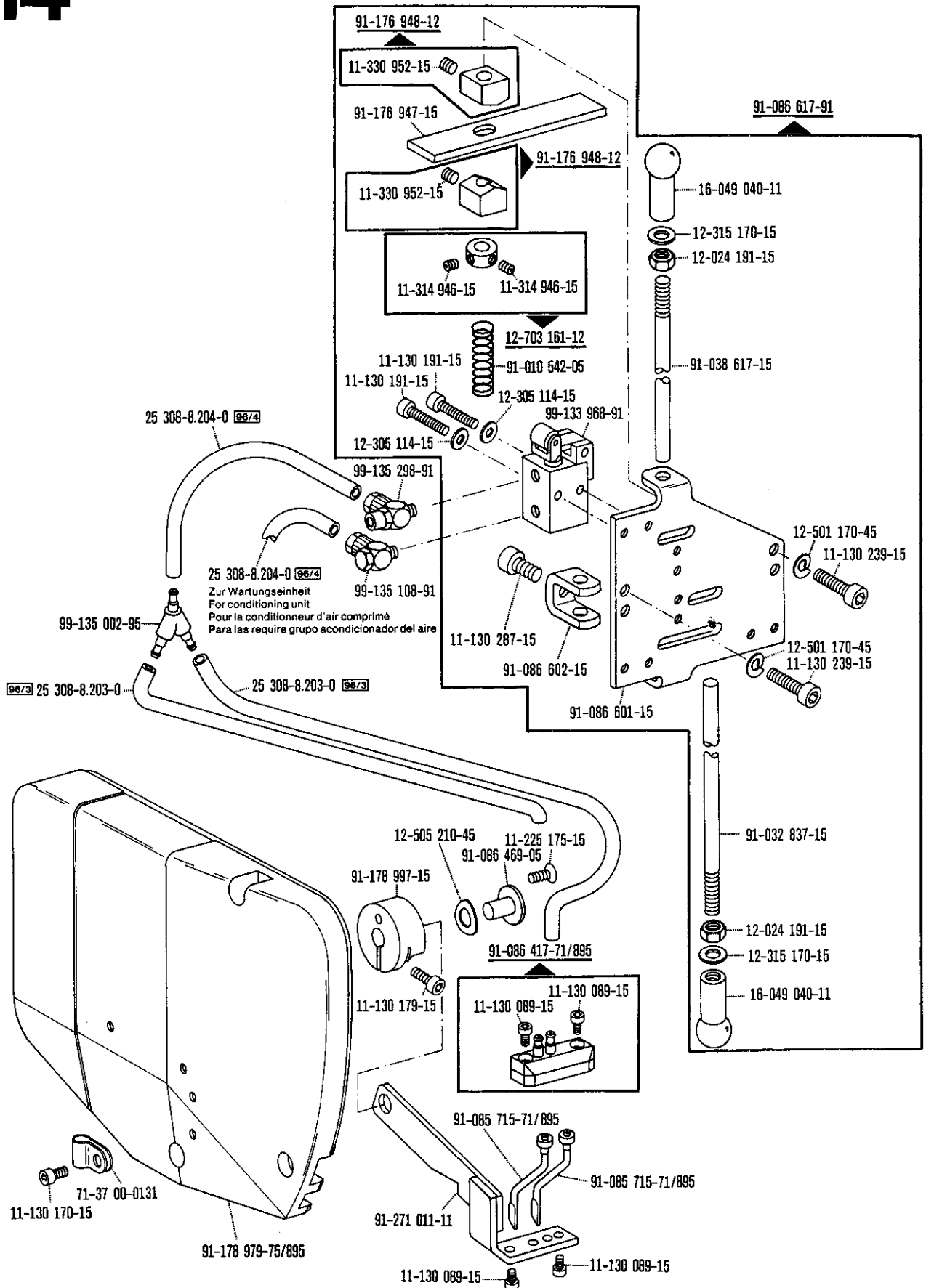

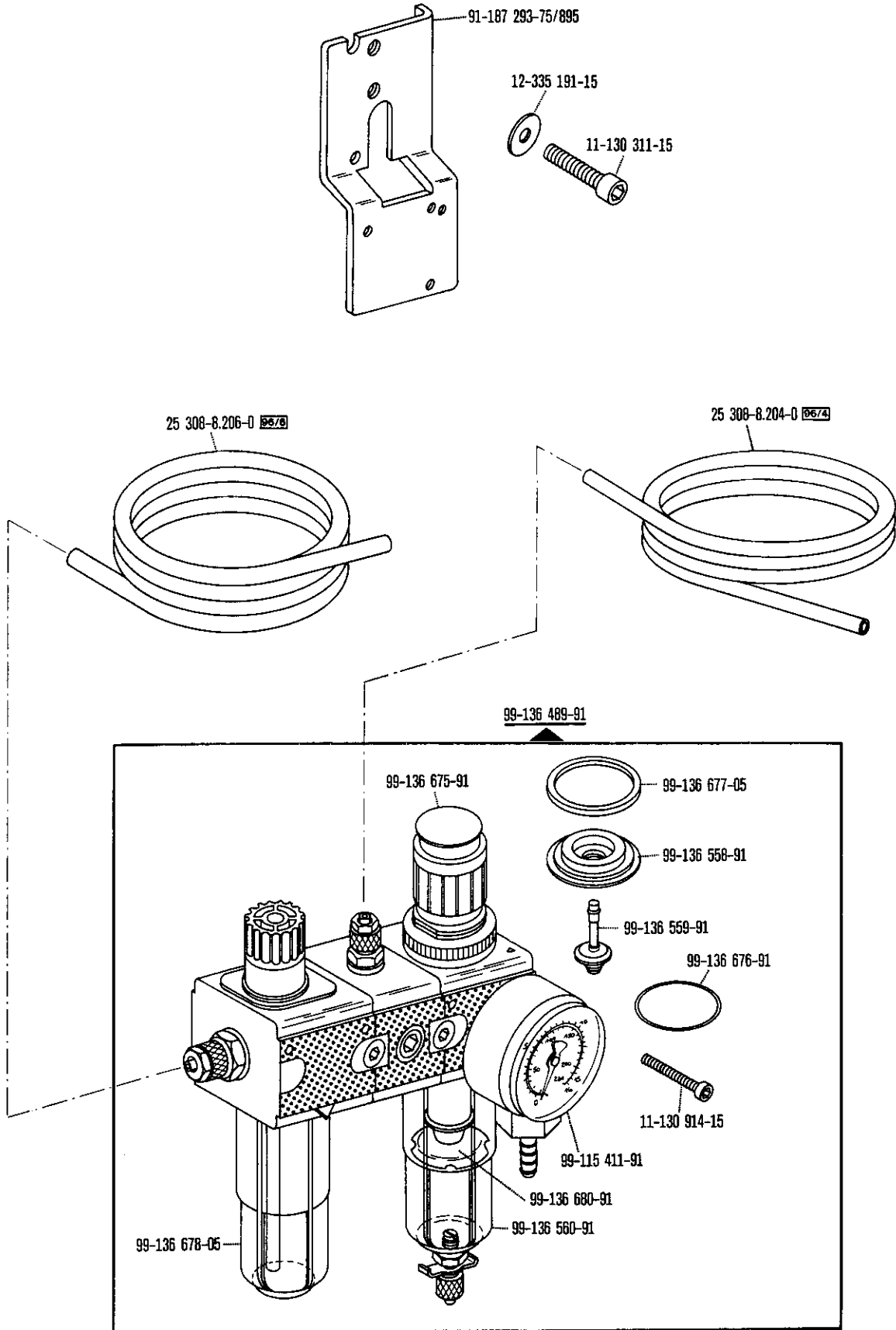

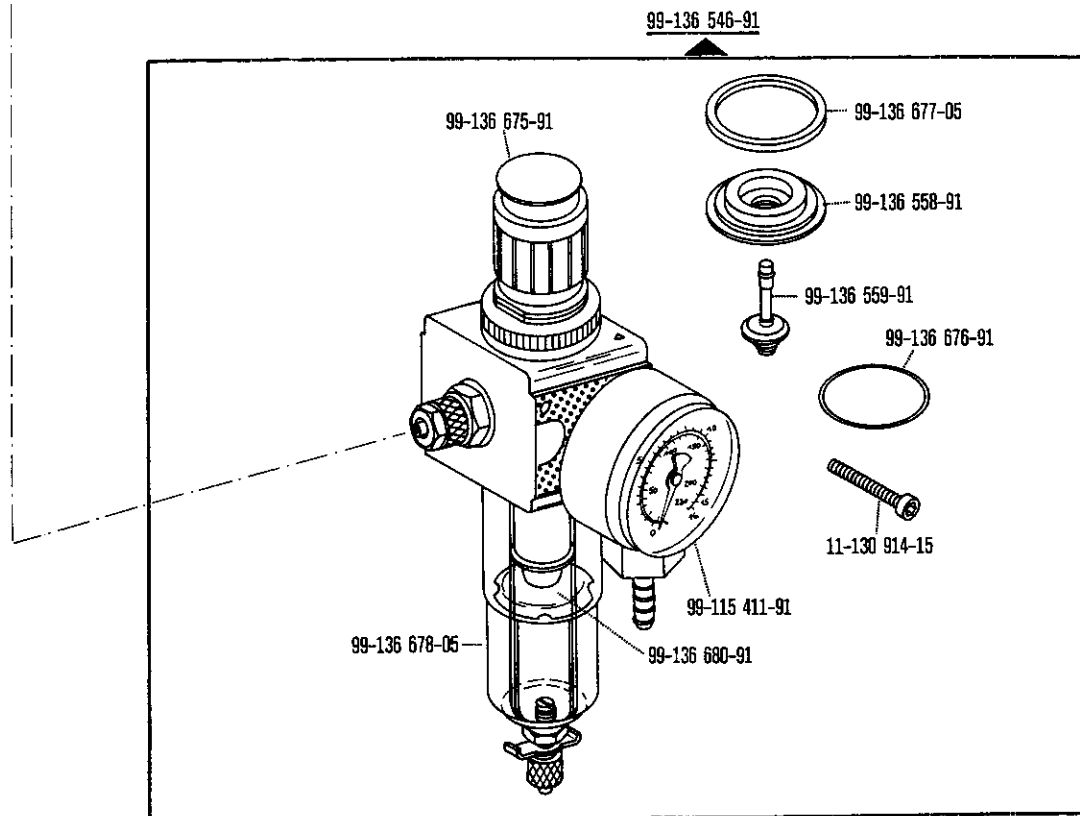
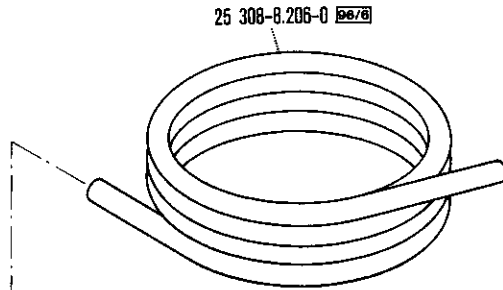
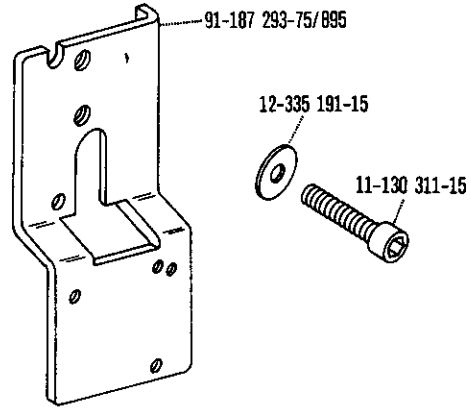

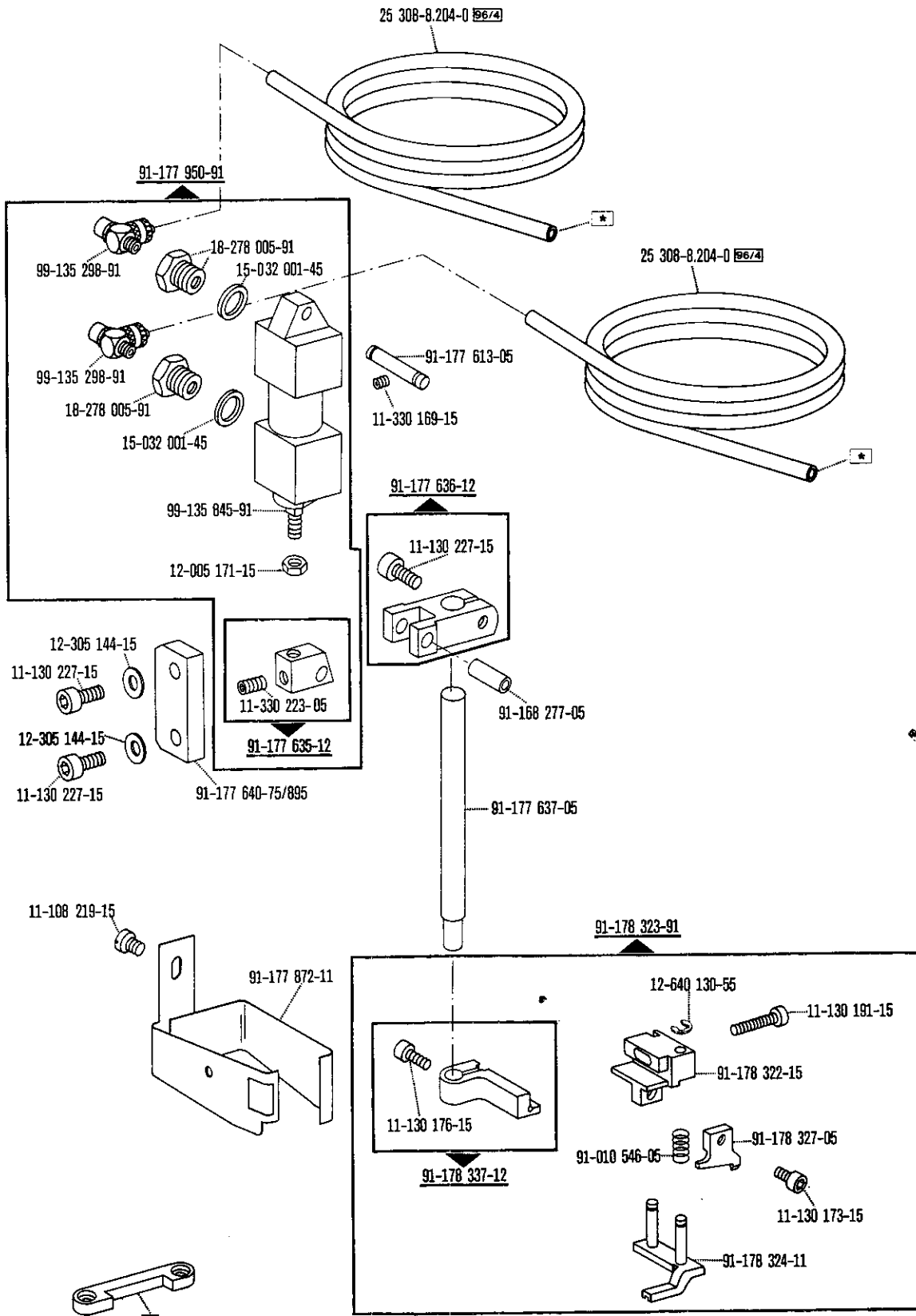

☐ siehe Erläuterungen Register 0
 see explanations in section 0
 voir légende registre 0

★ Anschluß siehe Seite 46
 For connection see page 46
 Raccord, cf. page 46

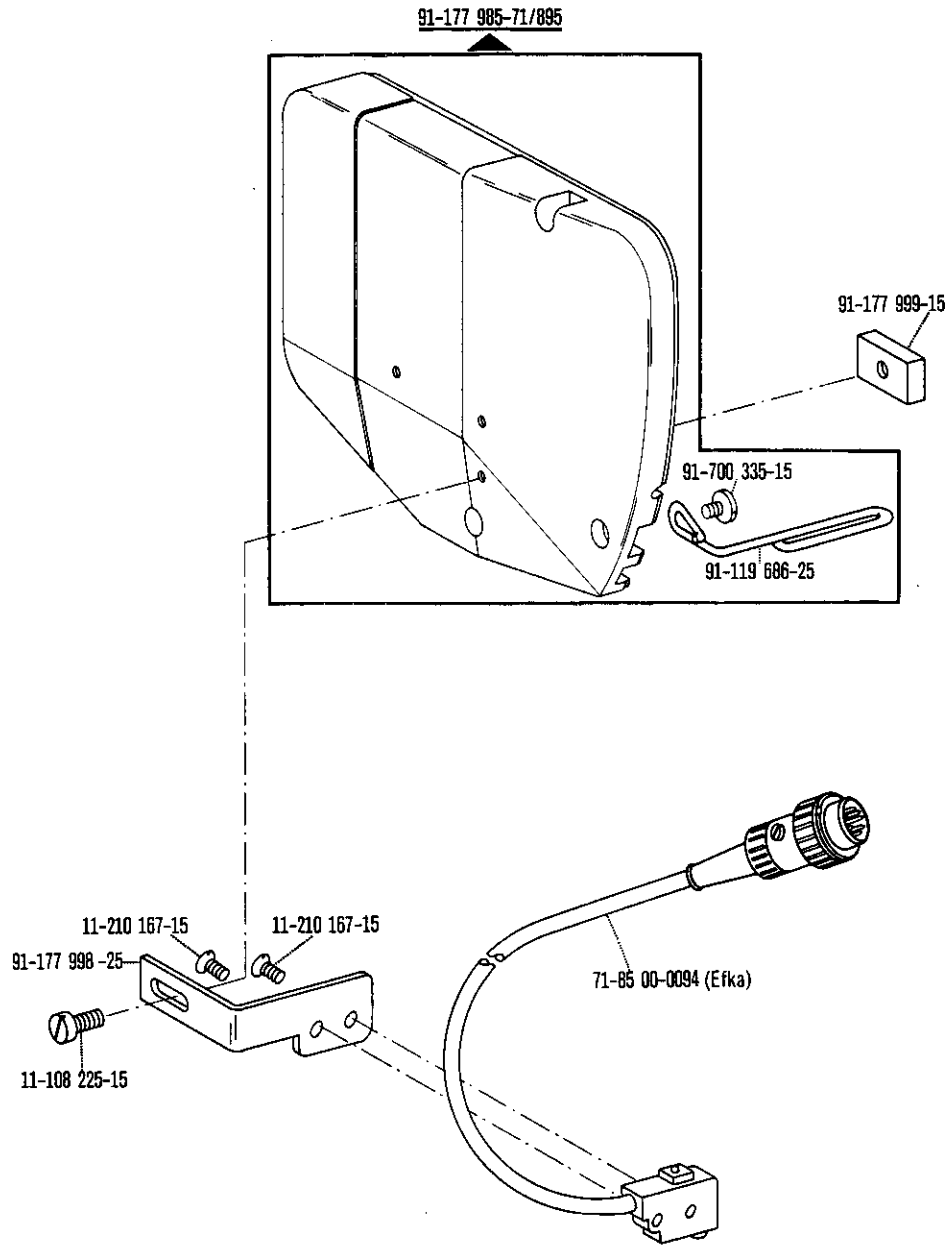

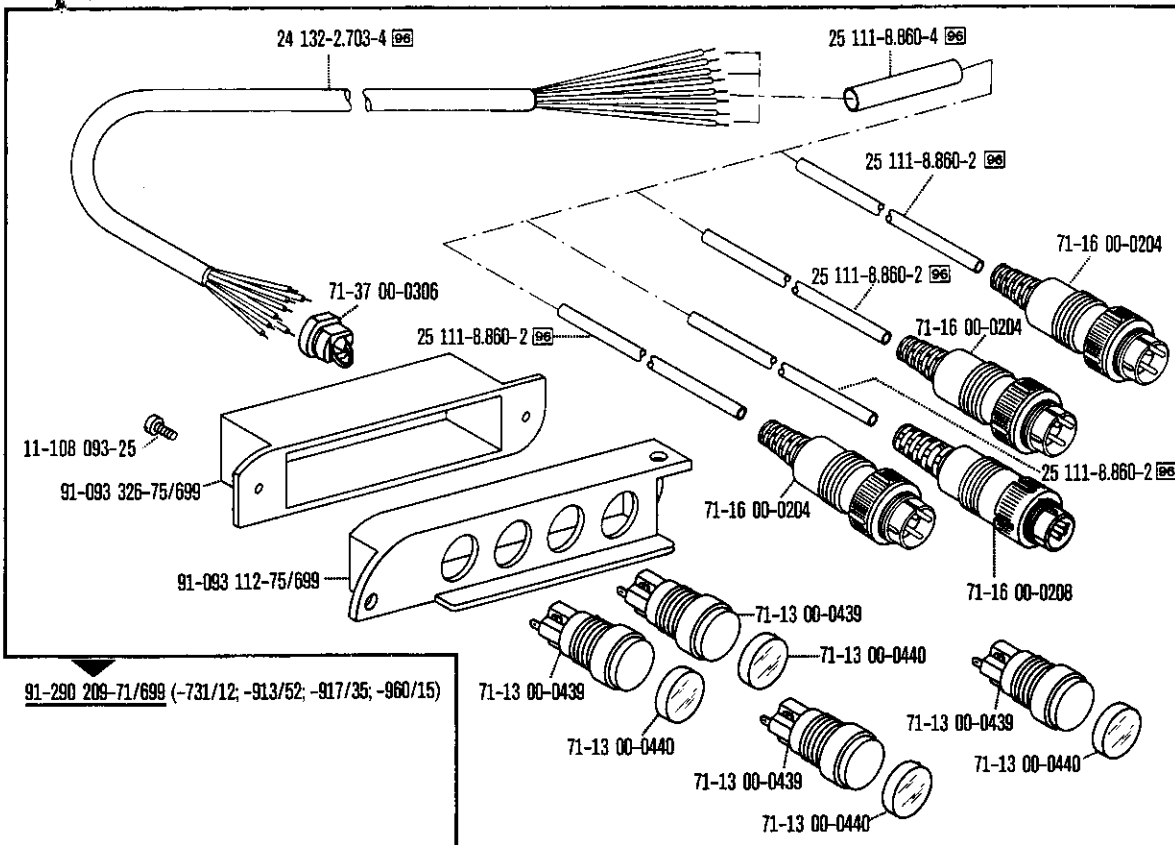
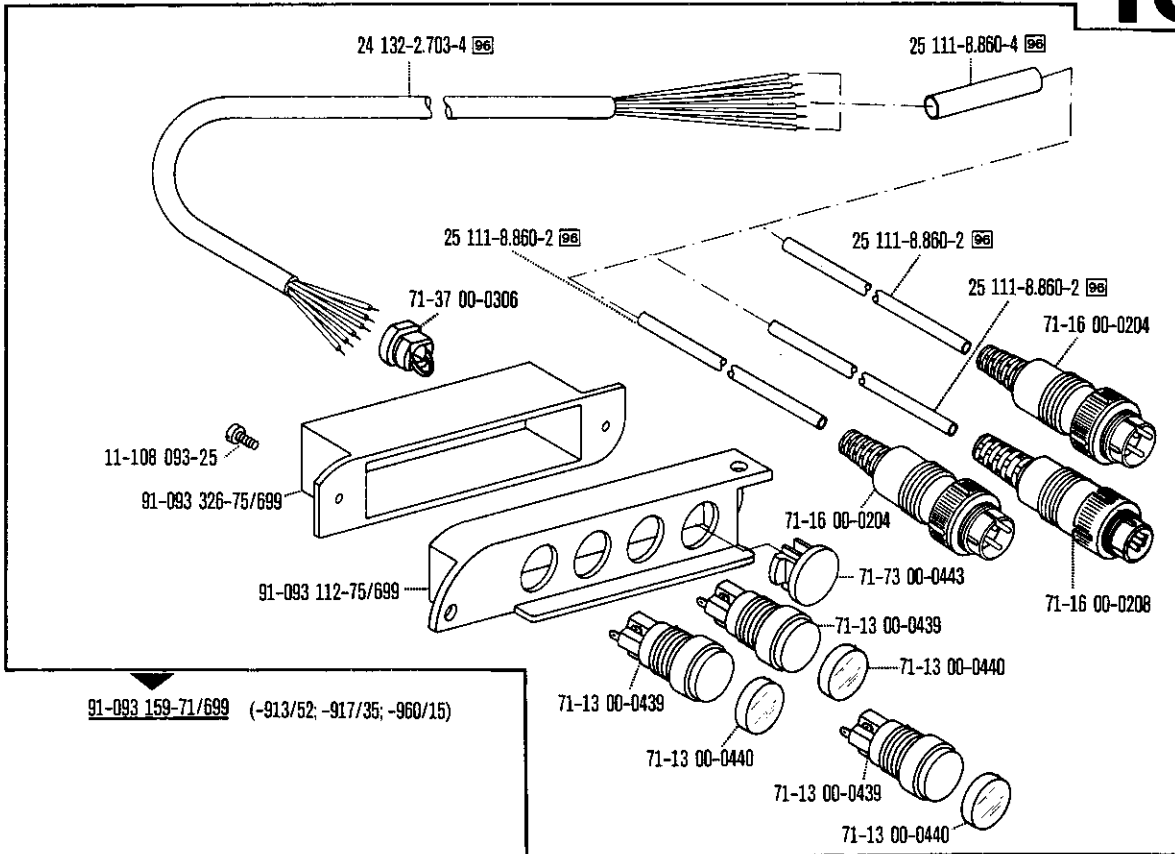

☐ siehe Erläuterungen Register 0
 see explanations in section 0
 voir légende registre 0

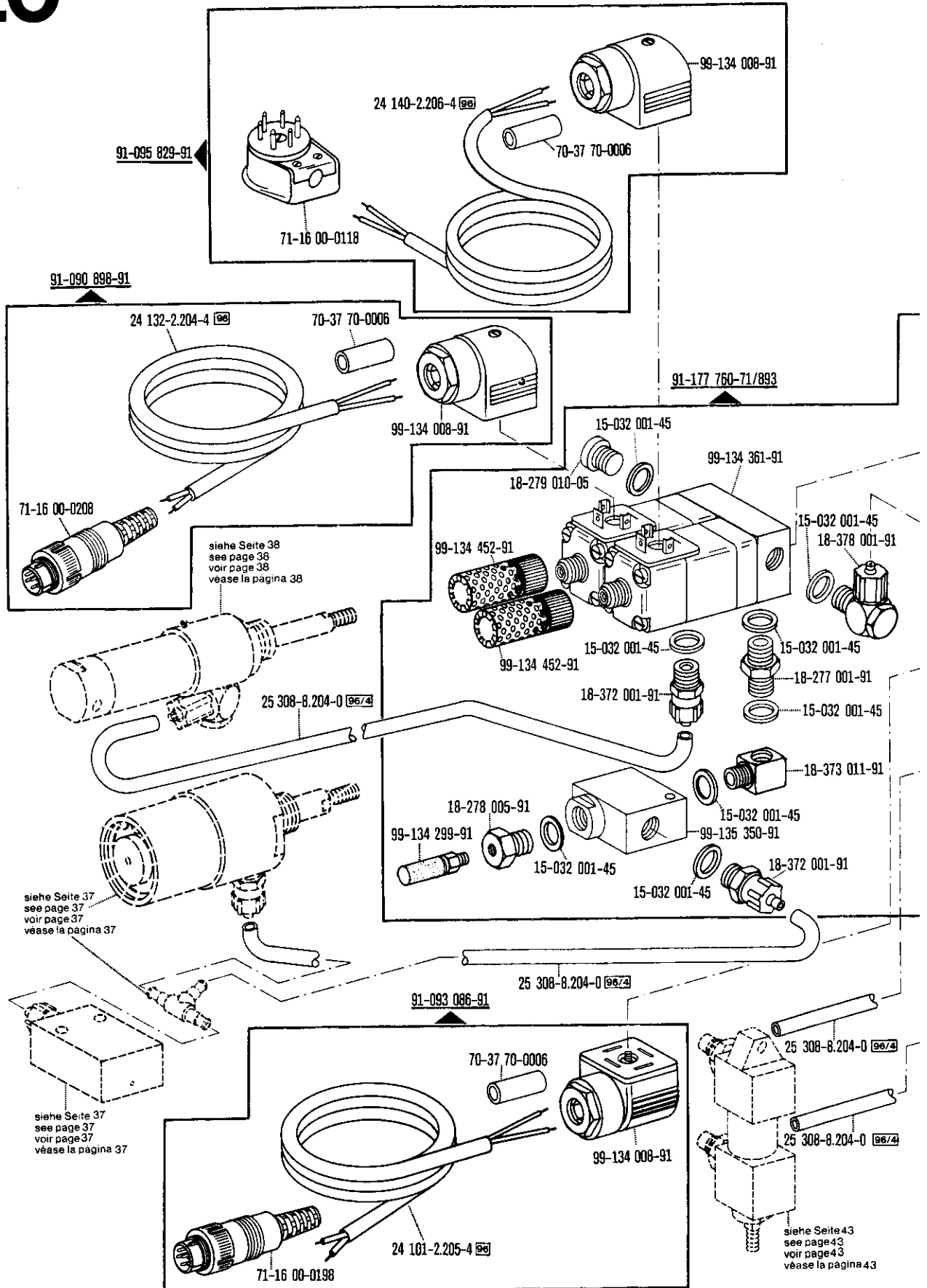

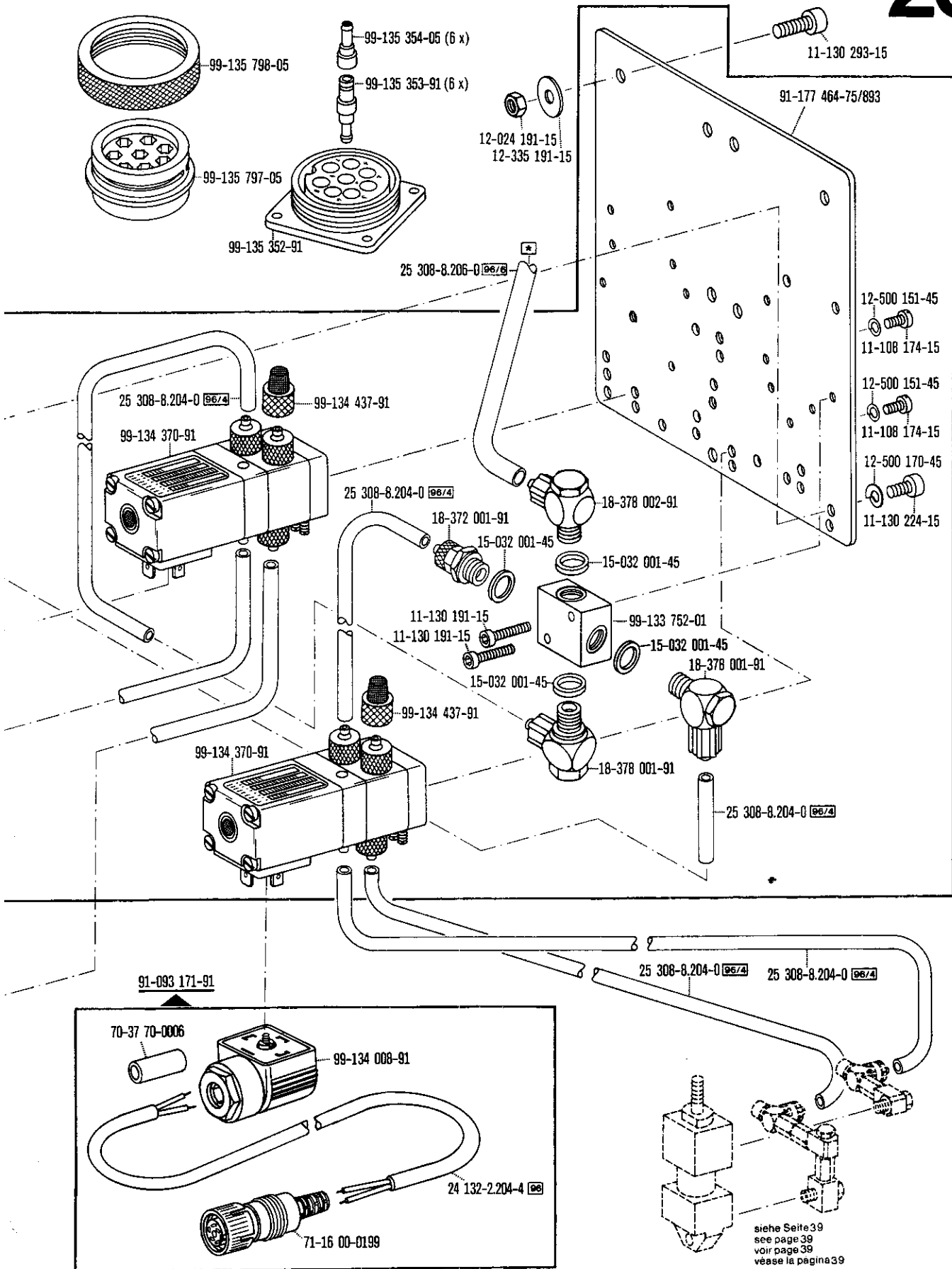

☐ siehe Erläuterungen Register 0
 see explanations in section 0
 voir légende registre 0

★ Zur Wartungseinheit
 For conditioning unit
 Pour la conditionneur d'air comprimé

siehe Seite 39
 see page 39
 voir page 39
 véase la página 39

21

Accessory parts Accessoires Accesorios

zur - pour
for - para PFAFF 5645 H; 5646 H

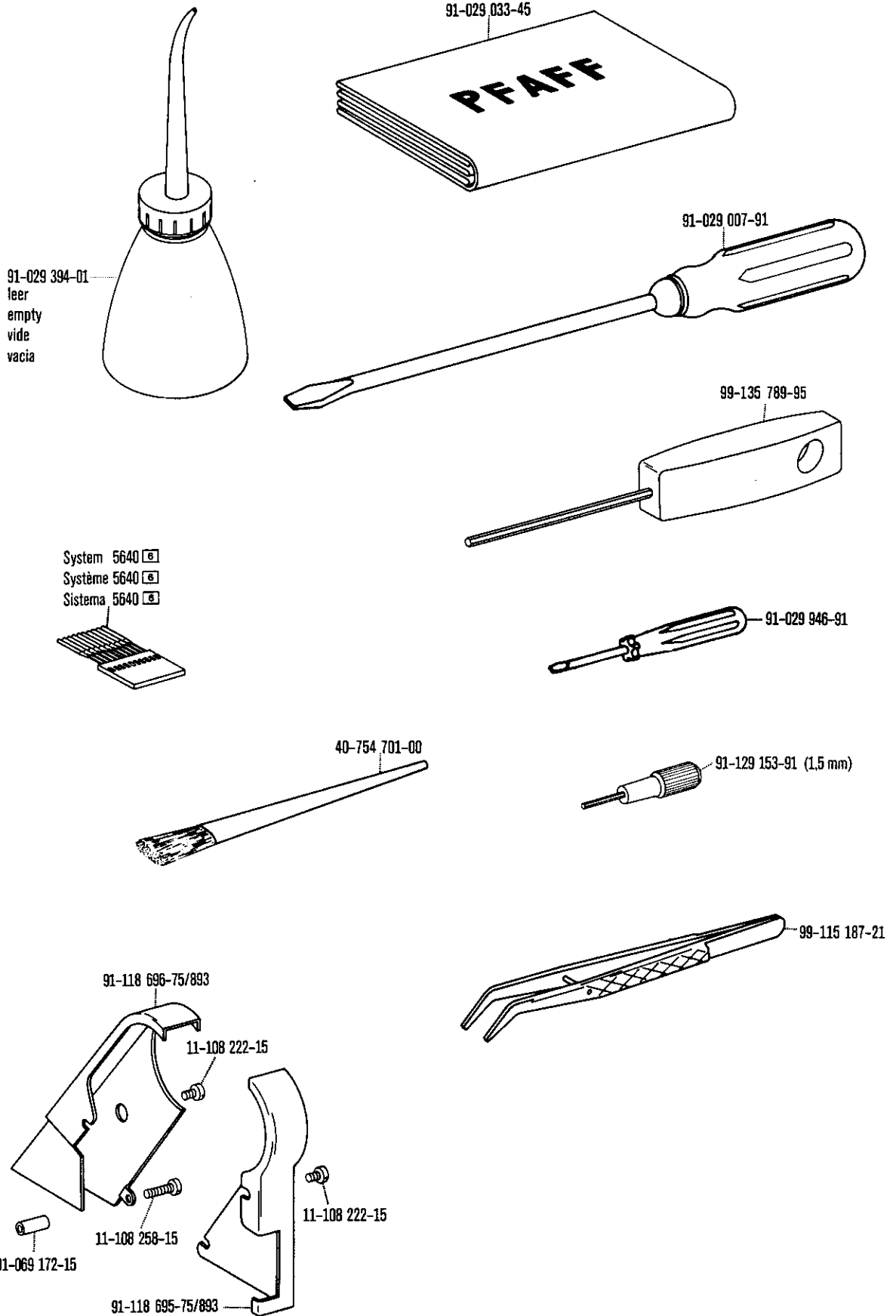

91-027 496-70/894 (PFAFF 5645 H)

91-027 535-70/894 (PFAFF 5646 H)

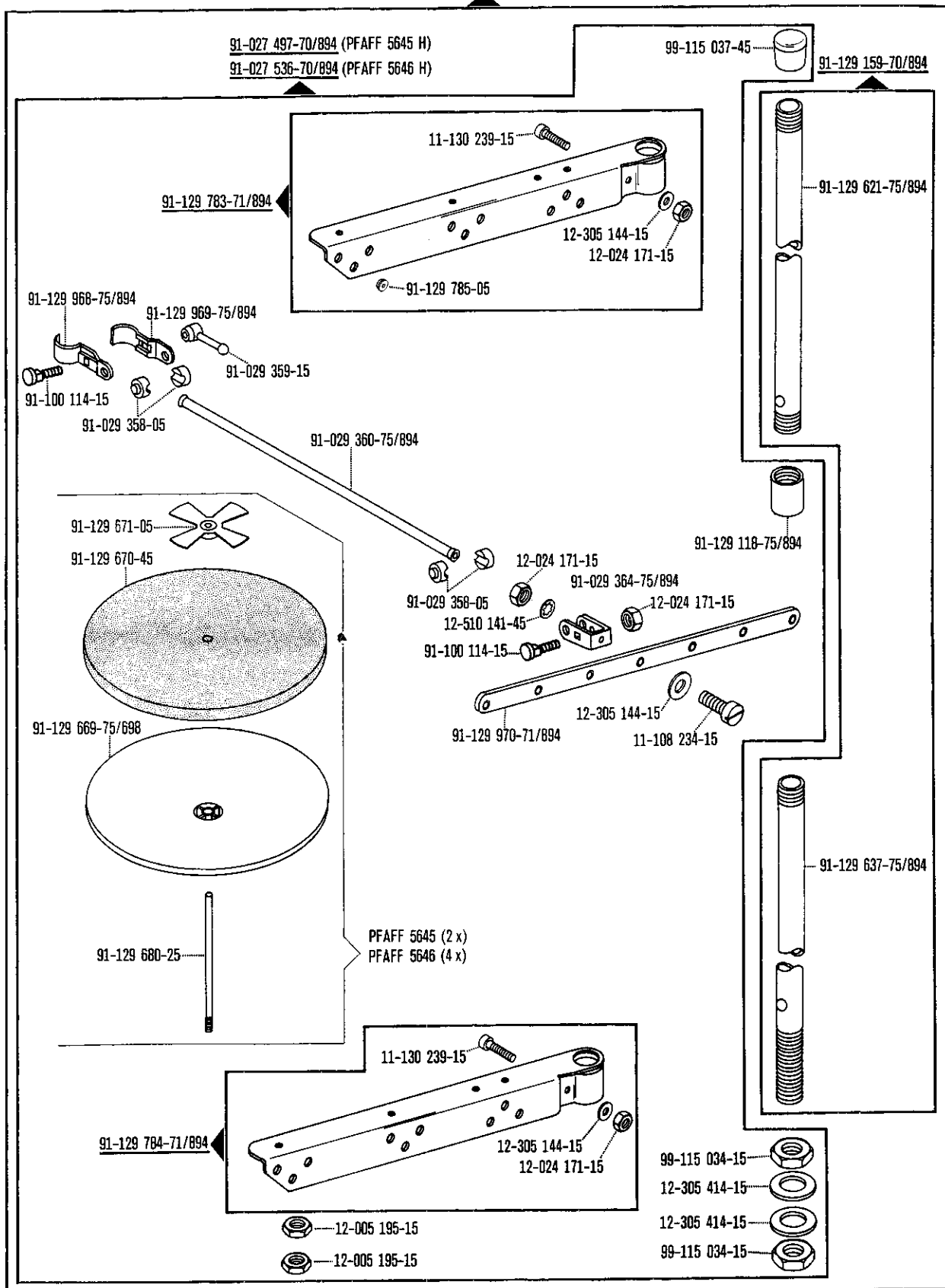

☐ siehe Erläuterungen Register 0
see explanations in section 0
voir légende registre 0

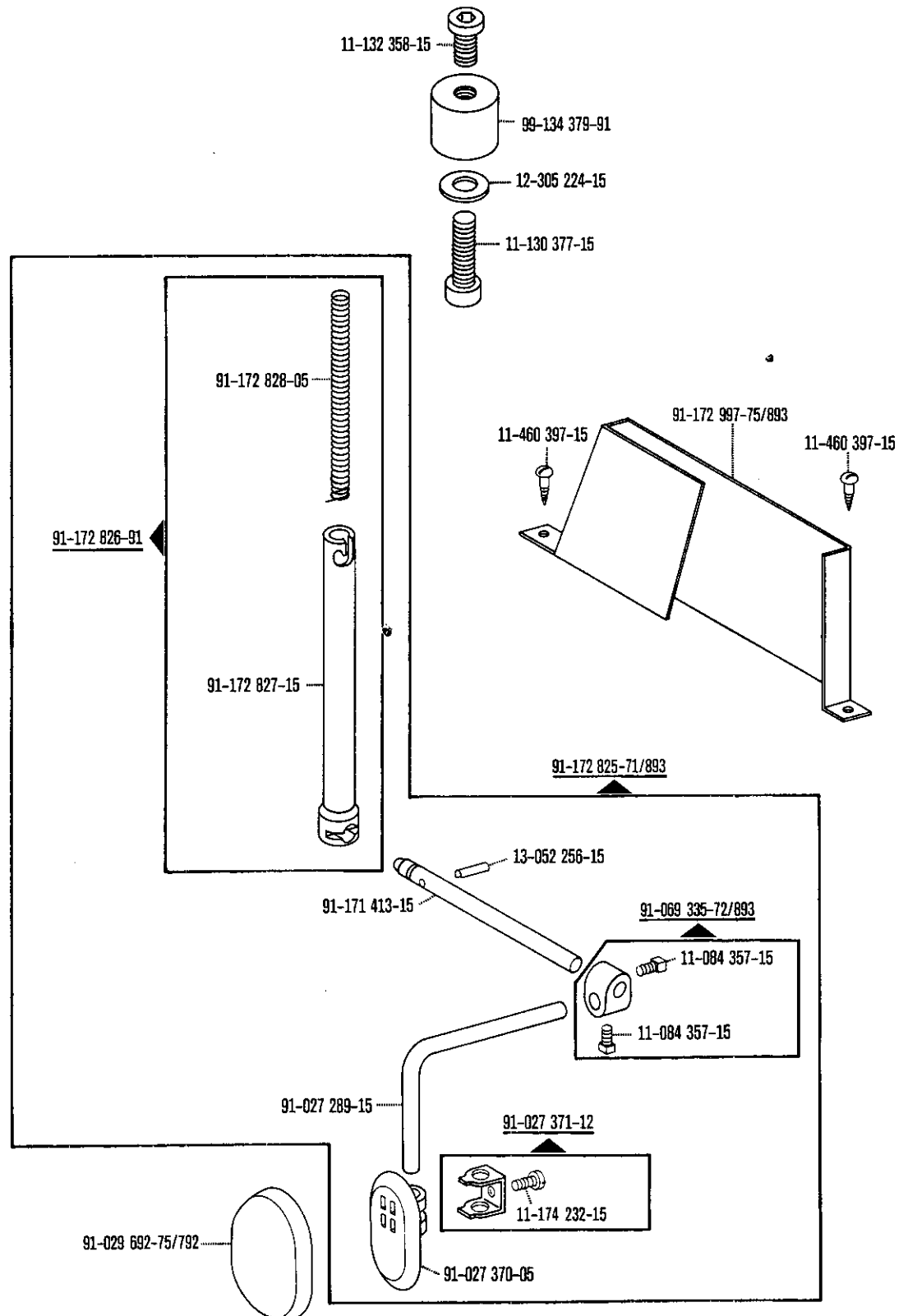

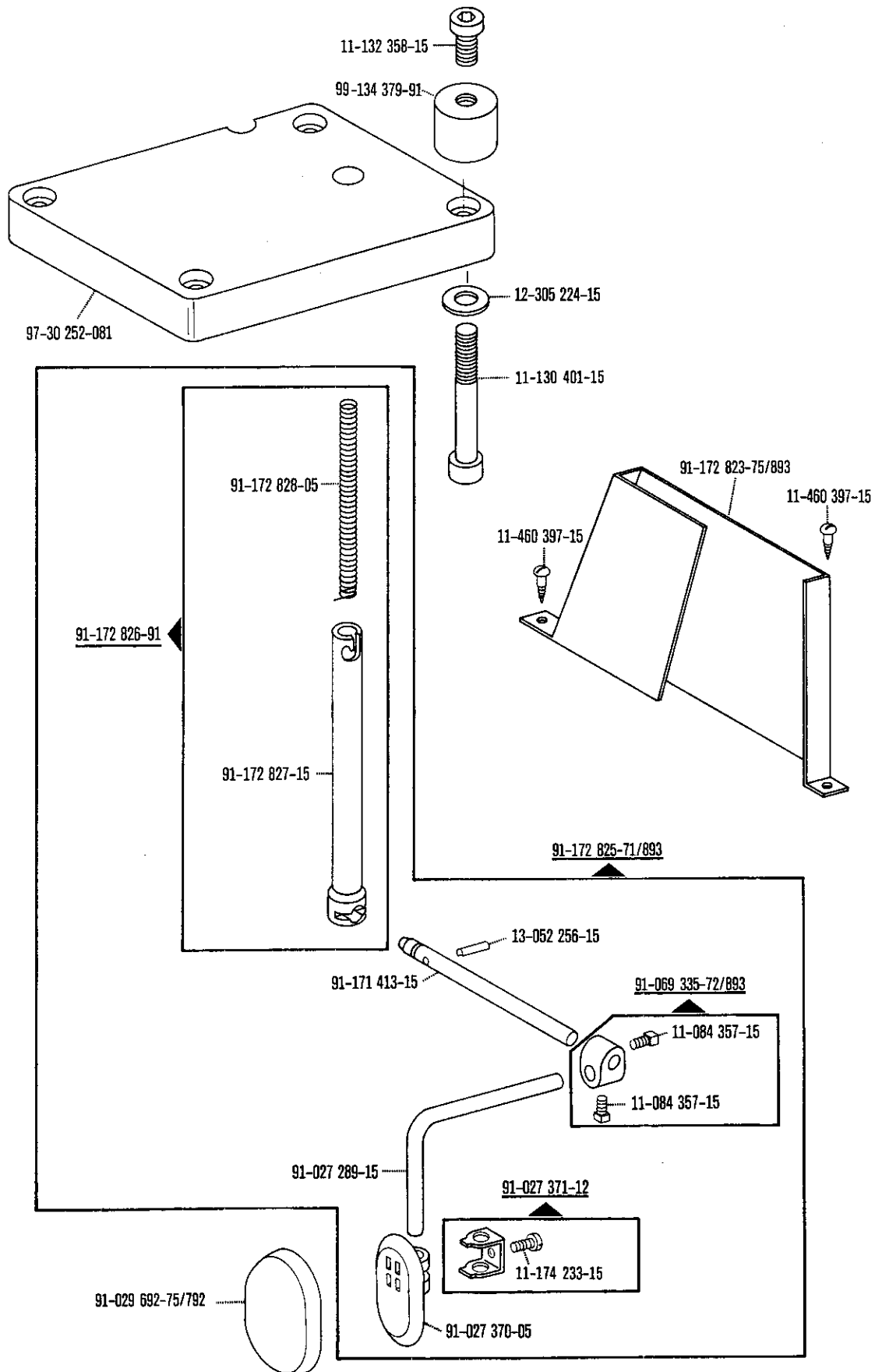

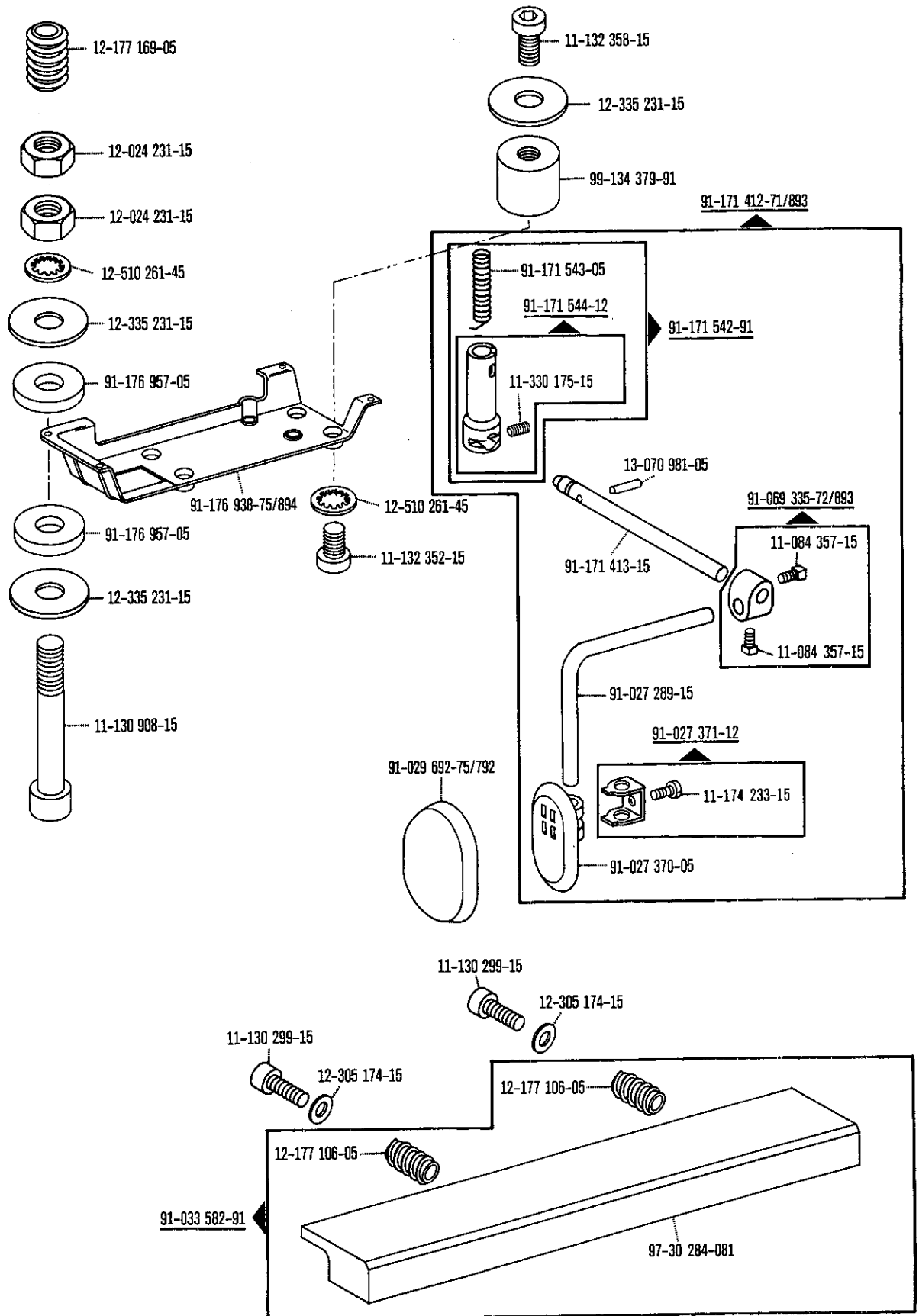

90/2

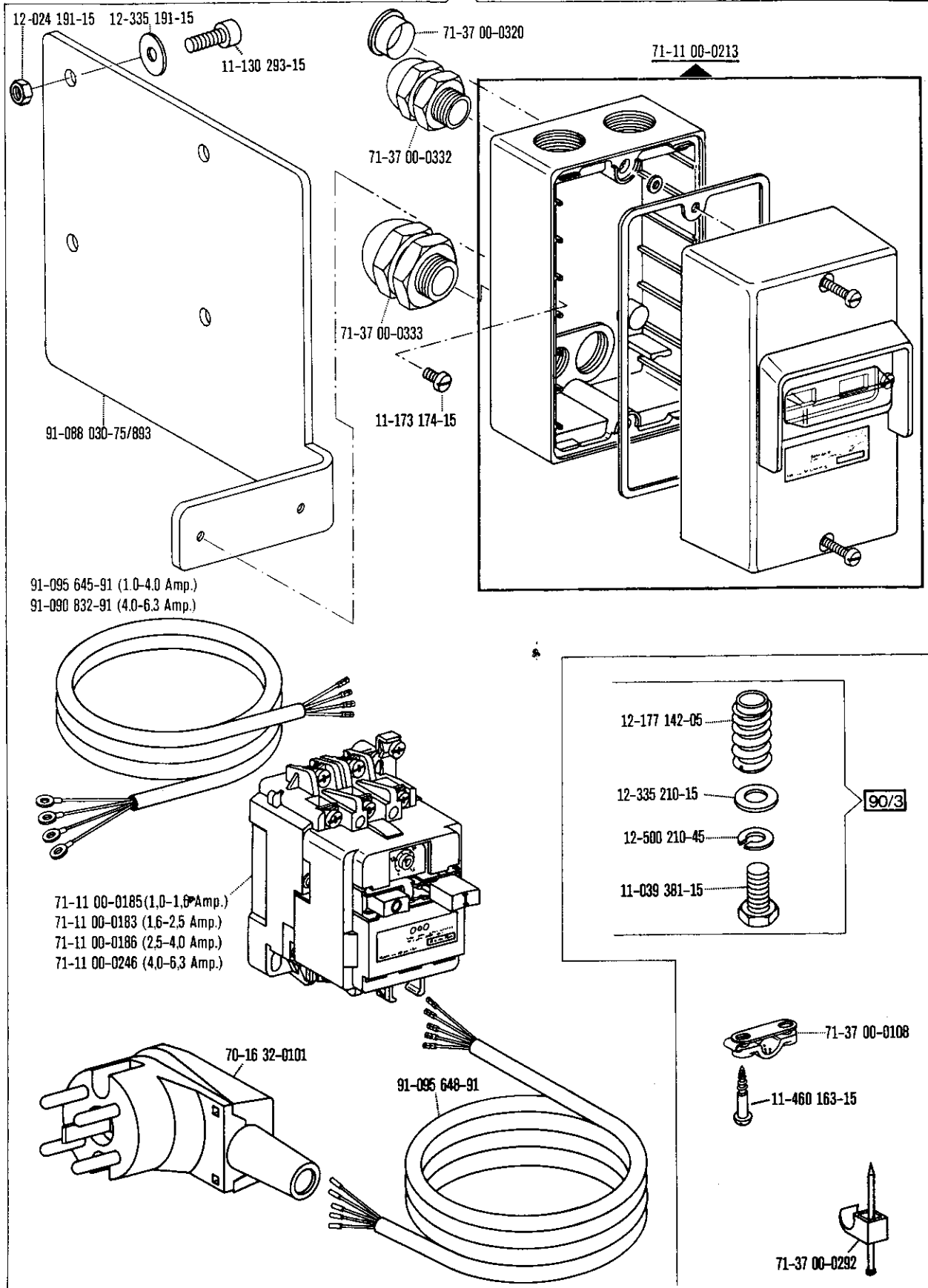

☐ siehe Erläuterungen Register 0
 see explanations in section 0
 voir légende registre 0

90/1

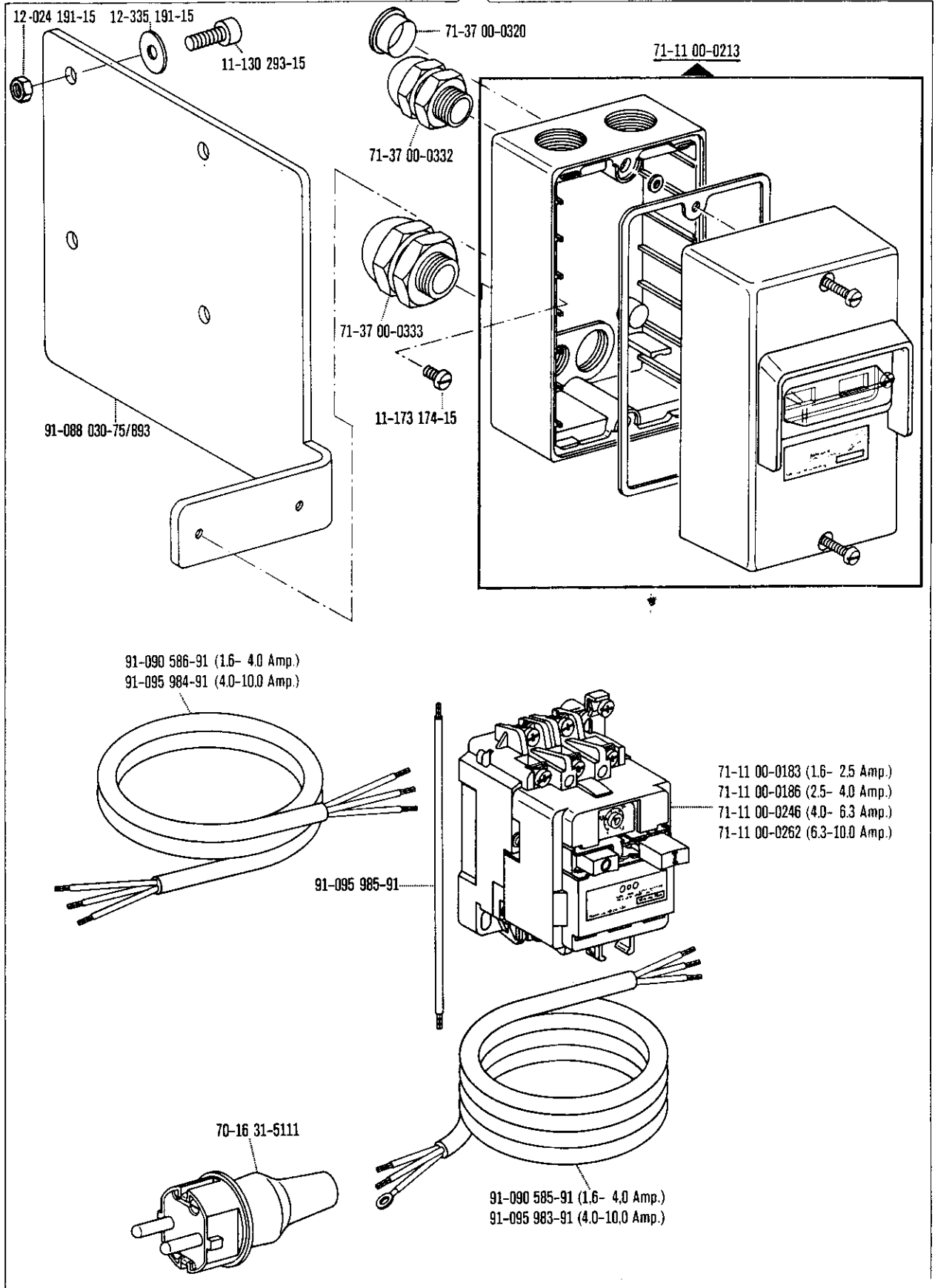

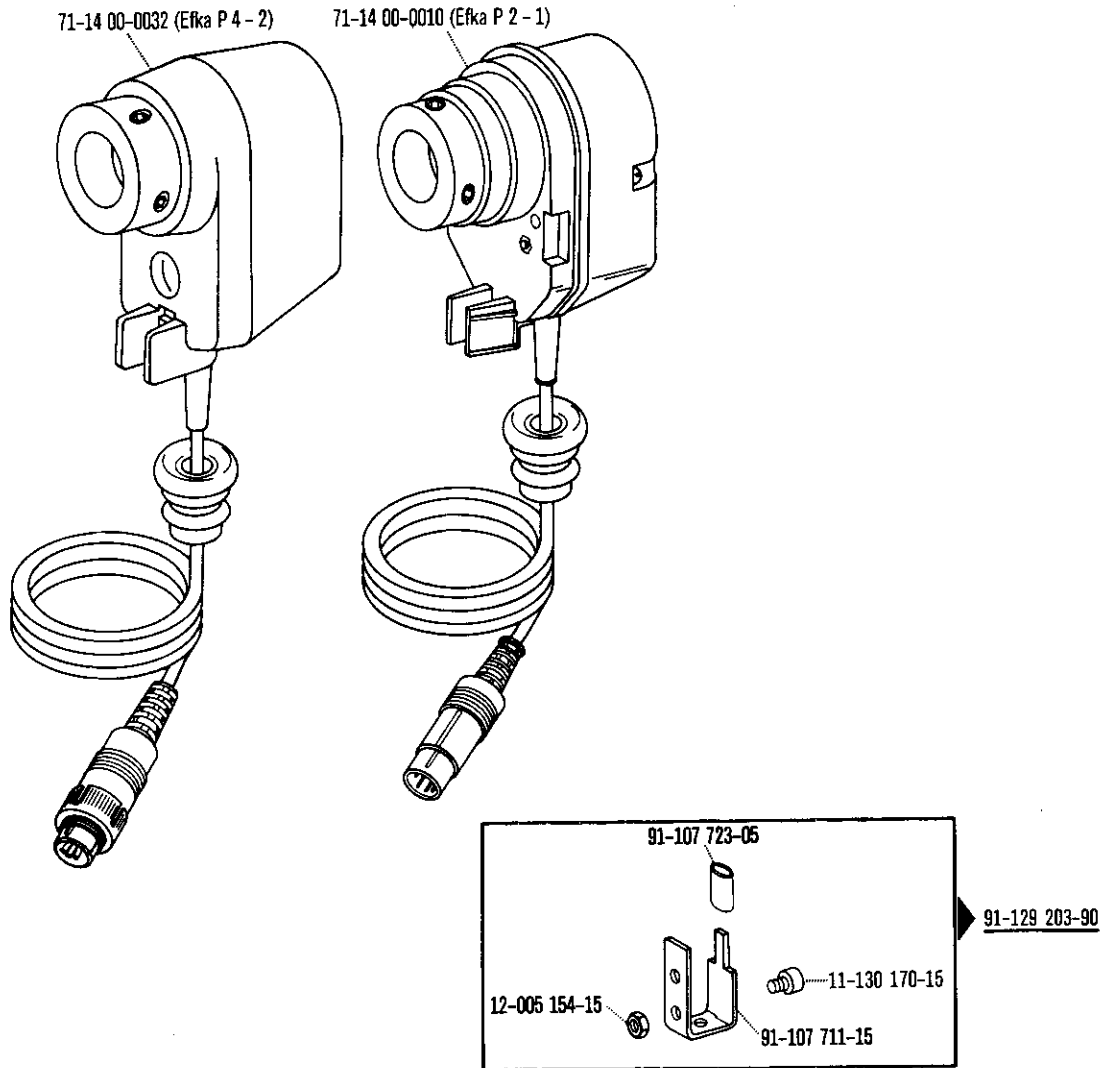

Einstellehren
Adjustment gauges
Calibres
Calibres de ajuste

zur - pour
for - para

PFAFF 5645 H; 5646 H

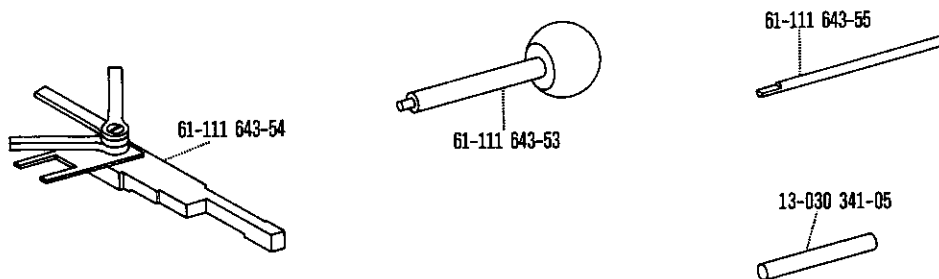

No.	Seite Page Pages Página	No.	Seite Page Pages Página	No.	Seite Page Pages Página	No.	Seite Page Pages Página
11-039 096-15	28	11-130 167-15	9	11-174 086-15	29	11-330 217-15	16, 17, 18, 36
11-039 222-15	28, 31	11-130 170-15	40, 55	11-174 089-15	18, 24, 36	11-330 223-05	43
11-039 225-15	9, 28, 31	11-130 173-15	10, 18, 36, 37, 43	11-174 089-25	12	11-330 223-15	11
11-039 300-15	13	11-130 176-15	43	11-174 167-15	31	11-330 277-15	11
11-039 381-15	53	11-130 179-15	40	11-174 170-15	9, 29	11-330 280-15	21
11-084 357-15	50, 51, 52	11-130 191-15	40, 43, 47	11-174 173-15	9	11-330 286-15	11
11-108 084-15	21, 35	11-130 224-15	15, 16, 22, 23, 27, 33, 38, 47	11-174 176-15	17	11-330 292-15	9
11-108 087-15	10, 22, 23, 26, 32	11-130 227-15	10, 13, 14, 15, 17, 19, 36, 43	11-174 232-15	50	11-330 952-15	10, 11, 14, 15, 16, 19, 22, 23, 25, 26, 27, 28, 30, 32, 33, 34, 40
11-108 090-15	19	11-130 233-15	15, 19, 30, 34	11-174 233-15	51, 52	11-330 960-15	11, 19, 27, 33
11-108 093-15	15, 31	11-130 239-15	40, 49	11-178 166-15	19	11-330 962-15	16, 28
11-108 093-25	45	11-130 245-15	37	11-186 965-15	15	11-335 169-15	18
11-108 132-15	28, 31	11-130 287-15	13, 25, 40	11-186 985-15	28, 30, 34	11-335 280-15	28, 31
11-108 171-15	20, 22, 24, 28, 29, 31	11-130 293-15	11, 20, 26, 28, 30, 31, 32, 34, 37, 47, 53, 54	11-210 074-15	29	11-335 902-15	12, 17
11-108 174-15	22, 23, 47	11-130 299-15	28, 31, 52	11-210 084-25	30, 34	11-341 166-15	11
11-108 177-15	9, 27, 33, 36	11-130 311-15	41, 42	11-210 167-15	44	11-341 901-15	11, 13, 16, 17, 18, 19, 28, 31
11-108 186-15	19	11-130 377-15	50	11-210 168-15	22, 23	11-341 902-15	12, 17, 19, 27, 33, 36
11-108 219-15	12, 43	11-130 401-15	51	11-210 174-15	12	11-341 904-15	10, 11
11-108 222-15	20, 48	11-130 903-15	16	11-210 216-15	20	11-341 905-15	12, 19
11-108 225-15	12, 14, 19, 21, 28, 38, 44	11-130 905-15	11, 16, 18, 27, 33	11-210 222-15	39	11-460 163-15	53
11-108 228-15	10, 19, 28, 37	11-130 906-15	28, 31	11-210 288-15	12	11-460 397-15	50, 51
11-108 234-15	20, 21, 27, 29, 33, 35, 49	11-130 908-15	52	11-225 175-15	40	12-005 154-15	16, 55
11-108 246-15	29, 35	11-130 914-15	41, 42	11-225 381-15	15	12-005 171-15	30, 34, 43
11-108 250-15	14	11-132 169-15	25, 28	11-225 902-15	26, 32	12-005 175-15	11, 39
11-108 250-25	35	11-132 217-15	10, 36	11-305 239-15	11, 28, 31	12-005 195-15	19, 37, 38, 49
11-108 258-15	48	11-132 223-15	36	11-314 166-15	24	12-005 215-15	11
11-108 285-15	16, 29	11-132 352-15	52	11-314 277-15	13, 15, 26, 27, 32, 33	12-017 170-15	25
11-108 288-15	27, 33	11-132 358-15	50, 51, 52	11-314 946-15	40	12-024 121-15	28
11-108 294-15	13, 26, 32	11-135 232-15	18	11-315 917-05	27, 33	12-024 171-15	11, 27, 28, 31, 33, 37, 49
11-108 846-15	11	11-135 292-15	26, 32	11-317 949-15	9	11-330 082-15	9, 24, 36
11-108 849-15	23, 38	11-135 538-15	21	11-330 166-15	17, 18, 27, 28, 31, 33	11-330 169-15	18, 26, 32, 36, 39, 43
11-108 858-15	24	11-173 174-15	53, 54	11-330 175-15	16, 52	12-024 171-25	35

No.	Seite Page Pages Página	No.	Seite Page Pages Página	No.	Seite Page Pages Página	No.	Seite Page Pages Página
12-024 191-15	13, 25, 40, 47, 53, 54	12-640 150-55	14, 22, 30, 34	14-215 022-13	10, 13, 16, 26, 32	16-437 040-55	56
12-024 231-15	52	12-640 170-55	16, 17, 18, 19, 27, 33, 36	14-215 025-13	9, 16, 25	16-437 050-55	56
12-177 106-05	52	12-640 200-55	18, 27, 28, 33	14-215 028-13	13, 27, 33	16-437 060-55	56
12-177 142-05	53	12-640 210-55	39	14-215 031-13	16, 19	16-437 070-55	56
12-177 169-05	52	12-640 220-55	15, 16, 26, 27, 32, 33	14-215 070-13	10, 18, 26, 27, 32, 33	16-437 080-55	56
12-305 114-15	18, 36, 37, 40	12-703 161-12	26, 32, 40	14-215 073-13	16, 18	16-437 909-55	56
12-305 144-15	23, 27, 33, 37, 43, 49	12-710 190-02	31	14-215 124-13	16, 19	17-035 232-65	35
12-305 174-15	22, 25, 26, 32, 52	13-030 310-05	13	14-215 124-43	17	18-277 001-91	46
12-305 224-15	50, 51	13-030 341-05	55	14-215 166-13	9	18-278 005-91	43, 46
12-305 414-15	49	13-030 377-05	26, 32	14-215 238-43	17, 36	18-279 010-05	46
12-315 140-15	28, 31	13-033 103-05	14	14-215 274-43	17	18-372 001-91	37, 46, 47
12-315 170-15	40	13-033 310-05	38	14-215 304-43	19	18-373 011-91	46
12-335 191-15	41, 42, 47, 53, 54	13-033 385-05	19	14-215 319-43	27, 33	18-378 001-91	38, 47
12-335 210-15	53	13-052 184-15	11	14-215 352-43	11	18-378 002-91	47
12-335 231-15	52	13-052 193-15	27, 33	14-218 040-01	11, 28, 31	40-754 701-00	48
12-349 122-05	11	13-052 256-15	50, 51	14-218 050-01	28	61-111 643-53	55
12-500 150-45	37	13-060 400-05	21	14-218 080-01	17	61-111 643-54	55
12-500 151-45	47	13-063 259-05	23	14-218 090-01	13, 27, 33	61-111 643-55	55
12-500 170-45	37, 47	13-068 187-15	28, 31	14-680 050-15	17	70-16 31-5111	54
12-500 210-45	53	13-070 981-05	52	14-680 060-15	12	70-16 32-0101	53
12-501 170-45	40	14-016 130-01	17	14-680 070-15	12	70-37 70-0006	46, 47
12-505 210-45	40	14-016 150-01	12	14-720 080-05	15	70-44 50-1194	30, 34
12-510 141-45	18, 49	14-016 151-91	12	14-720 110-05	15	71-11 00-0183	53, 54
12-510 261-45	52	14-016 153-01	12	15-032 001-45	37, 38, 43, 46, 47	71-11 00-0185	53
12-610 170-45	10, 17, 26, 32	14-018 623-01	17	15-120 002-05	31	71-11 00-0186	53, 54
12-610 190-45	11, 19, 27, 33	14-018 624-91	17	15-125 135-05	21	71-11 00-0213	53, 54
12-610 200-45	13, 16	14-018 643-01	12	15-280 034-01	21	71-11 00-0246	53, 54
12-610 210-45	9, 12	14-018 644-91	12	15-280 062-01	21	71-11 00-0262	54
12-610 230-45	14	14-210 220-01	16	15-718 051-51	11, 27, 33	71-13 00-0439	30, 31, 38, 45
12-610 250-45	13	14-215 007-13	10, 26, 32	15-822 336-01	21	71-13 00-0440	30, 31, 38, 45
12-610 280-45	16	14-215 013-13	16, 17, 18, 19, 25, 27, 28, 31, 33, 36	16-049 040-11	40	71-14 00-0010	55
12-610 310-45	9			16-437 020-55	56	71-14 00-0032	55
12-640 130-55	27, 33, 43			16-437 030-55	56	71-16 00-0118	46

No.	Seite Page Página	No.	Seite Page Página	No.	Seite Page Página	No.	Seite Page Página
71-16 00-0198	30, 34, 46	91-027 496-70/894	49	91-069 709-12	16, 28	91-100 114-15	49
71-16 00-0199	47	91-027 497-70/894	49	91-069 845-25	21	91-100 348-15	18, 24
71-16 00-0204	30, 31, 45	91-027 535-70/895	49	91-069 961-05	14	91-100 355-15	9
71-16 00-0208	38, 45, 46	91-027 536-70/894	49	91-085 715-71/895	40	91-101 756-05	15
71-16 00-0213	30, 34	91-027 630-91	5	91-086 316-91	37	91-101 758-15	15
71-19 00-0261	30, 34	91-029 007-91	48	91-086 417-71/895	40	91-105 447-25	14
71-19 00-0262	30, 34	91-029 033-45	48	91-086 469-05	40	91-107 204-15	14
71-21 00-0324	30, 34	91-029 358-05	49	91-086 601-15	40	91-107 711-15	55
71-37 00-0108	53	91-029 359-15	49	91-086 602-15	40	91-107 723-05	55
71-37 00-0131	40	91-029 360-75/894	49	91-086 617-91	40	91-118 103-05	26, 32
71-37 00-0292	53	91-029 364-75/894	49	91-086 638-25	37	91-118 148-05	13
71-37 00-0306	30, 31, 34, 38, 45	91-029 394-01	48	91-086 639-25	37	91-118 151-05	21
71-37 00-0320	53, 54	91-029 691-75/792	51	91-088 030-75/893	53, 54	91-118 196-12	9
71-37 00-0332	53, 54	91-029 692-75/792	50	91-090 585-91	54	91-118 275-93	12
71-37 00-0333	53, 54	91-029 946-91	48	91-090 586-91	54	91-118 509-05	21
71-42 00-0000	30, 34	91-032 837-15	40	91-090 832-91	53	91-118 600-91	16, 17, 19
71-73 00-0443	45	91-033 582-91	52	91-090 898-91	46	91-118 603-91	16
71-85 00-0094	44	91-038 617-15	40	91-093 063-05	30, 31, 38	91-118 612-05	13, 27, 28, 33
91-000 380-25	25	91-040 624-25	25	91-093 086-91	46	91-118 621-92	19
91-000 687-15	18	91-044 251-21	25	91-093 112-75/699	45	91-118 653-05	19
91-001 522-25	14	91-045 739-05	22	91-093 159-71/699	45	91-118 695-75/893	48
91-002 065-05	14	91-049 936-05	36	91-093 171-91	47	91-118 696-75/893	48
91-009 276-05	14	91-059 698-15	16	91-093 326-75/699	45	91-118 887-05	27, 28, 31, 33
91-009 343-05	22	91-064 583-05	26, 32	91-094 689-91	30, 34	91-118 893-92	16, 19
91-010 181-25	14	91-064 638-05	14	91-094 764-71/895	30, 34	91-119 009-05	10, 26, 32
91-010 183-05	14	91-067 017-05	27, 33	91-095 645-91	53	91-119 085-05	16, 17
91-010 542-05	40	91-069 079-72/895	26, 32	91-095 648-91	53	91-119 520-05	27, 33
91-010 546-05	43	91-069 118-05	18	91-095 829-91	46	91-119 566-05	10
91-011 253-12	18	91-069 132-15	15	91-095 983-91	54	91-119 686-25	21, 26, 32, 44
91-017 378-15	13	91-069 135-05	15	91-095 984-91	54	91-119 704-91	12
91-027 289-15	50, 51, 52	91-069 172-15	48	91-095 985-91	54	91-119 705-12	12
91-027 370-05	50, 51, 52	91-069 222-12	11, 14, 15	91-100 055-15	18	91-123 778-12	13, 15, 26, 27, 32, 33
91-027 371-12	50, 51, 52	91-069 335-72/893	50, 51	91-100 055-25	20, 29, 35	91-129 118-75/894	49

No.	Seite Page Pages Página	No.	Seite Page Pages Página	No.	Seite Page Pages Página	No.	Seite Page Pages Página
91-129 153-91	48	91-169 137-05	28	91-172 605-05	18	91-172 696-92	17, 36
91-129 159-70/894	49	91-169 506-04	9	91-172 609-45	9	91-172 697-91	17
91-129 203-90	55	91-169 556-05	16, 17, 18, 19, 27, 33, 36	91-172 613-01	9	91-172 698-05	17
91-129 621-75/894	49	91-169 594-15	14	91-172 620-25	14	91-172 702-92	17
91-129 637-75/894	49	91-169 698-05	15	91-172 622-15	18	91-172 703-91	17
91-129 669-75/698	49	91-169 727-15	23, 38	91-172 630-91	12	91-172 704-92	17
91-129 670-45	49	91-170 228-91	12	91-172 631-91	12	91-172 705-05	17
91-129 671-05	49	91-170 229-11	12	91-172 633-05	12	91-172 706-05	17
91-129 680-25	49	91-170 286-05	38	91-172 639-92	13	91-172 707-04	17
91-129 783-71/894	49	91-170 726-05	15	91-172 640-92	13	91-172 708-92	17
91-129 784-71/894	49	91-170 809-05	15	91-172 641-05	13	91-172 709-05	18
91-129 785-05	49	91-170 811-92	10	91-172 646-92	15	91-172 711-05	21
91-129 916-91	5	91-170 913-72/893	12	91-172 652-91	12	91-172 712-12	18, 36
91-129 917-91	5	91-171 175-12	27, 33	91-172 653-05	12	91-172 713-15	18
91-129 919-91	5	91-171 229-05	11, 27, 33	91-172 654-05	12	91-172 714-91	17
91-129 920-91	5	91-171 268-04	11	91-172 655-05	12	91-172 716-91	19
91-129 968-75/894	49	91-171 272-04	11	91-172 659-72/895	15	91-172 717-92	19
91-129 969-75/894	49	91-171 273-04	11	91-172 661-25	14	91-172 719-05	19
91-129 970-71/894	49	91-171 412-71/893	52	91-172 662-05	16	91-172 721-92	19
91-130 064-05	18	91-171 413-15	50, 51, 52	91-172 664-15	16	91-172 722-05	19
91-131 019-15	13	91-171 542-91	52	91-172 665-05	16	91-172 723-05	19
91-131 024-15	14	91-171 543-05	52	91-172 666-05	16	91-172 724-92	19
91-131 071-05	16	91-171 544-12	52	91-172 667-05	16	91-172 725-91	19
91-138 232-05	28, 31	91-171 602-71/895	21	91-172 668-15	16	91-172 727-05	19
91-140 362-05	10, 26, 32	91-171 808-05	10	91-172 669-05	16	91-172 728-05	19
91-140 363-12	10	91-171 875-12	11	91-172 672-15	16	91-172 729-05	19
91-140 372-05	10	91-171 883-15	15	91-172 676-05	16, 18, 26, 27, 32, 33	91-172 730-92	19
91-168 258-92	17	91-171 906-75/648	15	91-172 677-05	17	91-172 731-05	19
91-168 277-05	43	91-172 018-45	19	91-172 678-91	17	91-172 732-05	19
91-168 341-07	11, 28, 31	91-172 413-05	34	91-172 679-91	17	91-172 736-15	21, 35
91-168 347-05	13	91-172 602-71/895	21	91-172 687-05	16, 18	91-172 737-15	21
91-168 385-05	17	91-172 604-05	18	91-172 694-05	17, 36	91-172 738-75/895	20
91-168 480-15	12			91-172 695-92	17, 36	91-172 739-05	19

No.	Seite Page Pages Página	No.	Seite Page Pages Página	No.	Seite Page Pages Página	No.	Seite Page Pages Página
91-172 740-05	19	91-172 810-05	14	91-176 181-05	10, 26, 32	91-176 268-05	10
91-172 741-75/895	20	91-172 811-25	14	91-176 182-05	10, 26, 32	91-176 269-15	10
91-172 742-15	20	91-172 822-05	19	91-176 183-01	10, 26, 32	91-176 270-15	10
91-172 743-05	20	91-172 823-75/893	51	91-176 185-01	10, 26, 32	91-176 271-05	10
91-172 748-72/895	21	91-172 825-71/893	50, 51	91-176 188-05	10, 26, 32	91-176 274-91	11, 28, 31
91-172 748-75/895	21	91-172 826-91	50, 51	91-176 189-01	10, 26, 32	91-176 285-15	11
91-172 749-05	21	91-172 827-15	50, 51	91-176 192-05	10, 26, 32	91-176 286-15	11
91-172 750-71/951	21	91-172 828-05	50, 51	91-176 193-05	10, 26, 32	91-176 309-05	9
91-172 751-75/951	21	91-172 829-05	19	91-176 198-05	9	91-176 559-91	18
91-172 752-05	14	91-172 834-05	16, 18	91-176 199-92	9	91-176 836-15	38
91-172 753-05	21	91-172 843-05	18, 24	91-176 204-05	9	91-176 930-75/895	23
91-172 754-05	21	91-172 937-92	18	91-176 205-05	11, 28, 31	91-176 935-15	23
91-172 757-91	22	91-172 938-05	18	91-176 211-05	11	91-176 935-92	23
91-172 758-15	22	91-172 949-25	9	91-176 213-05	11	91-176 936-91	23
91-172 759-15	22	91-172 997-75/893	50	91-176 214-25	11	91-176 937-72/895	24
91-172 760-71/895	22	91-173 027-92	9	91-176 220-92	11	91-176 938-75/894	52
91-172 761-75/895	22	91-173 028-05	9	91-176 221-92	11	91-176 939-75/895	23
91-172 762-91	22	91-173 029-05	9	91-176 222-12	11	91-176 947-15	40
91-172 764-91	22	91-173 037-15	27, 33	91-176 223-15	11	91-176 948-12	40
91-172 766-15	22, 23	91-173 118-92	27, 33	91-176 224-05	11	91-176 950-71/895	21
91-172 767-25	22, 23	91-173 119-12	27, 33	91-176 225-12	11	91-176 952-75/895	21
91-172 768-21	22, 23	91-173 770-05	28	91-176 226-12	11	91-176 957-05	52
91-172 771-15	22	91-174 303-15	9	91-176 228-05	11	91-176 965-71/895	21
91-172 772-15	22	91-175 106-05	11, 28	91-176 235-05	10	91-177 001-12	18
91-172 773-11	22	91-175 217-15	15	91-176 236-05	10	91-177 002-05	18
91-172 776-05	21	91-175 646-15	31	91-176 238-91	11	91-177 005-05	18
91-172 777-75/895	21	91-175 648-15	28	91-176 239-11	11	91-177 006-05	18
91-172 778-05	16, 18	91-175 649-15	28, 31	91-176 242-15	11	91-177 007-15	18
91-172 798-91	19	91-176 175-91	10	91-176 243-91	13	91-177 008-05	18
91-172 799-11	18	91-176 176-15	10, 26, 32	91-176 244-12	13	91-177 010-02	18
91-172 802-01	18	91-176 178-05	10, 26, 32	91-176 245-12	13	91-177 010-05	18
91-172 805-91	14	91-176 179-02	10, 26, 32	91-176 246-91	13	91-177 015-92	18
91-172 806-11	14	91-176 180-05	10, 26, 32	91-176 267-05	10	91-177 024-12	16

No.	Seite Page Pages Página	No.	Seite Page Pages Página	No.	Seite Page Pages Página	No.	Seite Page Pages Página
91-177 049-15	29	91-177 613-05	39, 43	91-177 792-05	26, 27, 32, 33	91-177 859-71/895	21
91-177 130-15	37, 38	91-177 614-15	11	91-177 793-91	27, 33	91-177 867-05	18
91-177 168-25	18	91-177 616-91	13	91-177 794-12	27, 33	91-177 868-91	18
91-177 207-12	24	91-177 617-15	13	91-177 795-91	27, 33	91-177 869-91	39
91-177 208-05	24	91-177 619-91	9	91-177 796-15	27, 33	91-177 871-05	39
91-177 269-12	16	91-177 621-05	15	91-177 797-05	27, 33	91-177 872-11	43
91-177 270-05	16, 17, 18, 19, 36	91-177 622-05	15	91-177 798-05	33	91-177 877-72/895	14
91-177 271-15	16	91-177 623-15	14	91-177 799-05	27, 28, 31, 33	91-177 880-72/895	29
91-177 272-05	16	91-177 624-05	17	91-177 800-05	27, 33	91-177 883-95	11
91-177 273-12	16	91-177 625-72/895	20	91-177 801-05	27, 33	91-177 884-71/895	38
91-177 274-12	16	91-177 626-92	9	91-177 802-12	27, 33	91-177 885-05	38
91-177 275-05	16	91-177 627-72/893	20	91-177 803-92	27, 33	91-177 886-91	18
91-177 288-12	18	91-177 631-92	11	91-177 804-12	27, 33	91-177 902-05	17
91-177 293-91	9	91-177 632-91	17	91-177 805-05	27, 33	91-177 903-01	10
91-177 351-92	13	91-177 635-12	43	91-177 806-92	28	91-177 909-71/895	38
91-177 356-91	19	91-177 636-12	43	91-177 807-05	26, 32	91-177 911-04	11
91-177 357-45	9	91-177 637-05	43	91-177 808-15	27, 33	91-177 915-25	14
91-177 358-91	13	91-177 640-75/895	43	91-177 809-05	27, 33	91-177 918-15	28
91-177 464-75/893	47	91-177 642-12	37	91-177 810-91	26	91-177 919-05	28
91-177 580-92	17	91-177 647-25	10	91-177 811-12	26, 32	91-177 920-91	28
91-177 597-25	11	91-177 648-15	12	91-177 812-05	26, 27, 32, 33	91-177 921-15	28
91-177 598-15	11	91-177 649-71/698	15	91-177 813-12	28, 31	91-177 940-01	27, 33
91-177 599-05	11	91-177 650-91	15	91-177 814-05	28, 31	91-177 943-75/895	28
91-177 601-75/895	21	91-177 651-15	15	91-177 815-12	27, 33	91-177 950-91	43
91-177 603-75/895	20	91-177 750-91	11	91-177 816-05	27, 33	91-177 970-75/895	32
91-177 604-75/995	20	91-177 751-04	11	91-177 822-15	28	91-177 983-05	28
91-177 605-75/951	10	91-177 759-91	39	91-177 824-12	28	91-177 984-05	28
91-177 606-91	9	91-177 760-71/893	46	91-177 826-11	28, 31	91-177 985-71/895	26, 32, 44
91-177 608-91	9	91-177 767-91	9	91-177 828-05	26, 32	91-177 998-25	44
91-177 609-05	10	91-177 775-72/895	38	91-177 830-72/895	29, 35	91-177 999-15	44
91-177 610-05	10	91-177 790-75/895	26	91-177 832-72/893	29, 35	91-178 246-91	16
91-177 611-12	11	91-177 791-12	27, 33	91-177 833-45	28	91-178 248-12	16
91-177 612-05	39			91-177 834-45	28, 31	91-178 249-12	16

No.	Seite Page Pages Página	No.	Seite Page Pages Página	No.	Seite Page Pages Página	No.	Seite Page Pages Página
91-178 263-92	15	91-178 798-05	27, 33	91-178 964-75/895	35	91-290 209-71/699	45
91-178 264-25	15	91-178 799-91	18	91-178 965-15	35	91-700 091-15	25
91-178 265-92	15	91-178 801-90	18	91-178 966-71/895	29, 35	91-700 173-15	20, 29
91-178 266-25	15	91-178 819-91	25	91-178 967-05	29, 35	91-700 335-15	9, 21, 26, 32, 44
91-178 269-25	18	91-178 820-91	25	91-178 969-05	20	91-700 335-25	14, 17, 18, 36
91-178 270-25	17	91-178 824-25	25	91-178 979-75/895	40	91-700 412-25	20, 29, 30, 34, 35
91-178 274-05	9	91-178 825-25	25	91-178 980-05	34	91-700 486-25	20
91-178 283-15	28, 31	91-178 826-25	25	91-178 981-75/895	35	91-700 561-15	22
91-178 286-91	26, 32	91-178 827-25	25	91-178 983-15	31	91-700 689-15	16, 17
91-178 287-15	26, 32	91-178 828-05	25	91-178 984-12	25	91-700 961-15	11, 28, 31
91-178 309-12	30, 34	91-178 829-75/895	25	91-178 985-05	25	91-700 996-15	16
91-178 310-05	30, 34	91-178 853-25	9	91-178 986-05	25	91-701 039-15	15
91-178 311-15	30, 34	91-178 900-71/895	35	91-178 987-05	25	91-701 319-15	21
91-178 315-75/895	30, 34	91-178 902-05	31	91-178 988-05	25	91-701 344-15	14
91-178 316-12	30, 34	91-178 903-15	31	91-178 989-15	25	95-705 540-71/895	30, 34
91-178 319-91	30, 34	91-178 904-05	31	91-178 994-91	25	95-780 087-75/895	30
91-178 322-15	43	91-178 905-91	34	91-178 995-75/895	35	97-30-252-081	51
91-178 323-91	43	91-178 908-91	36	91-178 997-15	40	97-30 284-081	52
91-178 324-11	43	91-178 909-05	36	91-185 967-05	20	99-069 713-01	11, 34
91-178 327-05	43	91-178 910-45	31	91-187 293-75/893	41, 42	99-115 034-15	49
91-178 337-12	43	91-178 914-71/895	35	91-271 011-11	40	99-115 037-45	49
91-178 338-25	28, 31	91-178 926-05	31	91-271 012-91	31	99-115 187-21	48
91-178 582-05	18	91-178 927-11	31	91-271 013-15	31	99-115 411-91	41, 42
91-178 583-25	20	91-178 928-11	31	91-271 014-15	31	99-133 283-15	16, 17, 19
91-178 629-92	24	91-178 931-15	31	91-271 017-71/895	31	99-133 752-01	47
91-178 702-75/895	30	91-178 935-15	36	91-271 019-75/895	31	99-133 753-91	39
91-178 706-91	24	91-178 936-15	36	91-271 020-71/895	31	99-133 968-91	40
91-178 739-91	28	91-178 937-25	36	91-271 022-71/895	36	99-134 008-91	30, 34, 46, 47
91-178 740-25	28	91-178 940-15	25	91-271 028-05	32	99-134 207-05	39
91-178 741-15	28	91-178 941-15	25	91-271 040-91	32	99-134 296-45	16, 18, 26, 27, 32, 33
91-178 742-05	28	91-178 951-91	25	91-271 041-05	32	99-134 299-91	46
91-178 758-91	28, 31	91-178 952-05	25	91-271 048-05	25	99-134 326-91	37
91-178 768-00	19	91-178 953-05	25	91-290 207-71/895	30	99-134 361-91	46

No.	Seite Page Pages Página	No.	Seite Page Pages Página	No.	Seite Page Pages Página	No.	Seite Page Pages Página
99-134 370-91	47	24 101-2.205-4	38, 46				
99-134 373-91	38	24 132-2.204-0	30				
99-134 379-91	50, 51, 52	24 132-2.204-4	30, 31, 34, 46, 47				
99-134 437-91	47	24 132-2.703-4	45				
99-134 452-91	46	24 140-2.206-4	46				
99-134 828-91	30, 34	24 162-2.103-4	45				
99-135 002-95	40	24 162-2.534-4	30, 34				
99-135 108-91	40	25 111-8.860-2	45				
99-135 298-91	30, 34, 39, 40, 43	25 111-8.860-4	34, 45				
99-135 350-91	46	25 111-8.860-6	30, 34				
99-135 352-91	47	25 308-8.203-0	40				
99-135 353-91	47	25 308-8.204-0	30, 34, 37, 38, 39, 40, 41, 43, 46, 47				
99-135 354-05	47		41, 42, 47				
99-135 617-95	37	25 308-8.206-0	41, 42, 47				
99-135 711-91	39	25 534-3.005-0	31				
99-135 789-95	48	26 111-8.860-2	45				
99-135 797-05	47	26 534-3.005-0	10, 26, 32				
99-135 798-05	47	26 536-3.020-9	9				
99-135 845-91	43	26 536-3.030-9	17, 28				
99-135 885-91	37						
99-136 489-91	41						
99-136 546-91	42						
99-136 558-91	41, 42						
99-136 559-91	41, 42						
99-136 560-91	41						
99-136 675-91	41, 42						
99-136 676-91	41, 42						
99-136 677-05	41, 42						
99-136 678-05	41, 42						
99-136 680-91	41, 42						
280-1-120 144	5						
280-1-120 247	5						
294-1-102 312	12, 34						