

3586 -12/02 -13/01

TEILELISTE

PARTS LIST

LISTE DE PIÈCES

LISTA DE PIEZAS

Diese Teileliste hat für Maschinen ab nachfolgender
Seriennummer Gültigkeit:

This parts list applies to machines from the following
serial numbers onwards:

Cette liste de pièces est valable pour les machines au
numéros de série à partir de:

Esta lista de piezas tiene validez para máquinas a partir del
número de serie siguiente:

2 762 067 →

Alle Informationen und Abbildungen waren zum Zeitpunkt der Druckgebung auf dem neuesten Stand.

Technische Änderungen vorbehalten!

Der Nachdruck, die Vervielfältigung sowie die Übersetzung - auch auszugsweise - aus PFAFF-Teilelisten ist nur mit unserer vorherigen Zustimmung und mit der Quellenangabe gestattet.

At the time of printing, all information and illustrations contained in this document were up to date.

Subject to alteration!

The reprinting, copying or translation of PFAFF Parts lists whether in whole or in part, is only permitted with our previous permission and with written reference to the source.

Au moment de la remise à l'imprimeur, toutes les informations et figures se rapportant à cette machine correspondaient à l'état actuel des connaissances.

Sous réserve de modifications techniques!

Aucune reproduction, polycopie ou traduction - même par extraits - des listes de pièces PFAFF ne peut être effectuée, à condition d'en indiquer l'origine, sans notre autorisation expresse.

Todas las informaciones e ilustraciones de este manual estaban al día en el momento de entregarse para su impresión.

¡ Salvo modificaciones técnicas!

La reimpresión, reproducción y traducción - aunque sólo sea parcial - de las listas de piezas PFAFF sólo está permitida con nuestro permiso previo e indicando la fuente.

**PFAFF Industriesysteme
und Maschinen AG**

Hans-Geiger-Str. 12 - IG Nord

D-67661 Kaiserslautern

	Seite Page Page Página
0 Wichtiger Hinweis	0 - 1
Important note	
Avis important	
Observación importante	
1 Vorwort	1 - 1
Foreword	
Avant-propos	
Notas preliminares	
2 Erläuterungen der Schlüsselzeichen	2 - 1
Explanation of key markings	
Explication des symboles	
Explicaciones de los signos clave	
3 Basismaschine	
Basic machine	
Machine de base	
Máquina básicas	
3.01 Gehäuseteile	3 - 1
Housing sections	
Parties du corps	
Piezas del cárter	
3.02 Kopfteile	3 - 2
Needle head parts	
Pièces de tête	
Piezas de la cabeza	
3.03 Armteile	3 - 4
Arm parts	
Pièces de bras	
Piezas del brazo	
3.04 Grundplattenteile	3 - 6
Bedplate parts	
Pièces du plateau fondamental	
Piezas del cárter	
4 Y-Antrieb	4 - 1
Y drive	
Système de commande Y	
Grupo de accionamiento "Y"	

		Seite Page Page Página
5	X-Antrieb X drive Système de commande X Grupo de accionamiento "X"	5 - 1
6	Abdeckplatte vorn Front cover plate Plaque de recouvrement avant Placa de cubrimiento delantera	6 - 1
7	Stoffübernahme Material take-over unit Pince-ouvrage Sujetatelas	7 - 1
8	Ölfangwanne Oil drip pan Caster d'huile Bandeja colectora de acei	8 - 1
9	Bausatz für Zuführtisch Kit for infeed plate Kit pour table de chargement Juego de montaje de la mesa de alimentación	9 - 1
10	Wartungseinheit Air filter / lubricator Conditionneur d'air comprimé Grupo acondicionador del aire comprimido	10 - 1
11	Pneumatische Ausrüstung Pneumatic equipment Equipement pneumatique Equipo neumático	11 - 1
12	Elektrische Ausrüstung Electrical equipment Equipement électrique Equipo eléctrico	
12.01	Fadenwächter Thread monitors Contrôleur de fil Detector del hilo	12 - 1

	Seite Page Page Página
12.02 Einbaumotor	12 - 2
Built-in motor	
Moteur incorporé	
Motor incorporado	
12.03 Bedienfeld	12 - 3
Control panel	
Panneau de commande	
Panel de mandos	
12.04 Steuergerät	12 - 4
Control device	
Boîte de commande	
Caja de mandos	
12.05 Tastschalter	12 - 9
Push-button	
Interrupteur à bouton-poussoir	
Interruptor pulsador	
13 Gestell mit Anbauteilen	13 - 1
Stand with assembly parts	
Bâti avec éléments de montage	
Bancada con piezas de montaje	
14 Garnrollenständer	14 - 1
Reel stands	
Porte-bobines	
Portacarretes	
15 Einstellehren	15 - 1
Adjustment gauges	
Calibres	
Calibres de ajuste	
16 Teile zur Tischplatte	16 - 1
Parts for table top	
Pièces du plateau	
Piezas para el tablero	
17 Ablagebox	17 - 1
Collection box	
Boîte à prince	
Caja de apilado	

	Seite Page Page Página
18 Schmiermittel-Übersicht	18 - 1
Overview of lubricants	
Tableau de lubrifiants	
Tabla de lubricantes	
19 Optionen	
Options	
Options	
Opciones	
19.01 Bausatz Bündelklammer	19 - 1
Bundle clamp kit	
Jeu de pièces pour pince-paquet	
Juego de piezas para pinzas para	
19.02 Bausatz Klemmeinrichtung für Kleinteile	19 - 2
Clamp device kit for small parts	
Jeu de pièces de serrage pour petites pièces	
Juego de montaje dispositivo de sujeción para piezas pequeñas	
20 Index (Teilenummern / Seitenzahlen)	20 - 1
Index (part numbers / page numbers)	
Index (numéros de pièces, de pages)	
Index (números de pieza / números de página)	

Achtung!



Wir machen ausdrücklich darauf aufmerksam, daß Ersatz- und Zubehörteile, die nicht von uns geliefert werden, auch nicht von uns geprüft und freigegeben sind. Der Einbau und / oder die Verwendung solcher Produkte kann daher u. Umständen konstruktiv vorgegebene Eigenschaften Ihrer Maschine negativ verändern. Für Schäden, die durch die Verwendung von Nicht-Originalteilen entstehen, übernehmen wir keine Haftung!

Caution!



We warn you expressively that spare parts and accessories that are not supplied by us are not tested and released by us. Fitting or using these products may therefore have negative influences on features that depend on the machine design. We are not liable for any damage caused by the use of non-Pfaff parts!

Attention!



Nous attirons expressément votre attention sur le fait que les pièces de rechange et accessoires qui n'ont pas été livrés par nous n'ont pas non plus été contrôlés et agréés par nous. C'est pourquoi le montage et/ou l'utilisation de telles pièces peut éventuellement entraîner l'altération des caractéristiques de construction de votre machine. Par conséquent, nous n'assumons aucune responsabilité pour les dommages causés par l'emploi de pièces qui ne sont pas d'origine!

¡Atención!



Se hace observar que en el caso de piezas de recambio y accesorios que no hayan sido suministrados por nosotros, quiere decir que non han sido sometidas por nuestra parte a un control y que no se les ha dado el visto bueno. Por esta razón, el montaje y/o empleo de tales productos puede repercutir negativamente en las características previstas en su máquina. ¡Para los daños que eventualmente pudiesen presentarse al utilizar piezas no originales, no asumimos ninguna garantía!

- Die Seriennummer der Maschine, für die diese Teileliste Gültigkeit hat, ist auf der Titel-seite aufgeführt.
 - Alle Teile sind so abgebildet, wie sie in der Maschine funktionsmäßig zusammengehören.
 - Gestrichelt dargestellte Teile zeigen angrenzende Teile aus anderen Funktionsgruppen.
 - Im oberen Teil der Bildseiten befindet sich eine Gesamtansicht der Maschine .
 - Der Einbauort der dargestellten Teile wird durch eine gerasterte Fläche gekennzeichnet.
 - Einrahmungen auf den Bildseiten zeigen, aus welchen Einzelteilen sich die Gruppenteile zusammensetzen.
 - Die auf den Bildseiten verwendeten Schlüsselzeichen (; 2 ; 3 usw.) sind im Kapitel "Erläuterungen der Schlüsselzeichen" aufgelistet.
-
- The serial number of the machine to which this parts list applies is indicated on the cover page.
 - All parts are illustrated in function groups with the parts which they function together with in the machine.
 - Parts illustrated with broken lines are parts from other function groups which border on the illustrated function group.
 - The above section of the page of illustrations contains a total view of the machine. The place for the installation of the parts pictured here is marked by the grid.
 - The framed-in sections on the illustration pages show the individual parts comprising a group.
 - The key markings used on the illustrated pages (; 2 ; 3 etc.) are listed in the chapter "Explanation of key markings".
-
- Le numéro de série de la machine pour laquelle cette liste de pièces est valable est indiqué sur la première page.
 - Toutes les pièces sont représentées en fonction de leur groupement fonctionnel dans la machine.
 - Les pièces hâchurées indiquent les pièces limitrophes de groupes de fonctions différents.
 - La partie supérieure des pages de figures comprend une présentation globale de la machine. L'emplacement des pièces représentées est signalé par quadrillages.
 - Les parties encadrées sur les pages à illustrations représentent les pièces individuelles formant groupe.
 - Vous trouverez au chapitre "Explication des symboles" une liste des symboles utilisés sur les pages de figures (; 2 ; 3 etc.)
-
- El número de serie de la máquina para la cual tiene validez esta lista de piezas va indicado en la página de título.
 - Todas las piezas están ilustradas tal como aparecen en la máquina para su funcionamiento.
 - Las piezas representadas con rayitas muestran piezas colindantes de otros grupos de funciones.
 - En la parte superior de las páginas ilustradas se puede ver una vista en conjunto de la máquina.
 - El lugar de montaje de la pieza representada va caracterizada mediante una superficie reticulada.
 - Los recuadros en las páginas ilustradas indican las piezas individuales de que se componen los grupos.
 - Los signos clave (; 2 ; 3 ; etc.) empleados en las páginas con ilustraciones van listados en el capítulo "Explicaciones de los signos clave".

- 3** **Geklebt**
Part cemented
Pièce collée
Pieza pegada
- 3/2** **Geklebt mit UHU-Plus.**
Cemented with UHU-Plus.
Pièce collée avec UHU-Plus.
Pieza pegada con UHU-Plus.
- 3/4** **Selbstklebend**
Self-adhesive
Auto-adhésif
Autoadhesivo
- 6** **Nadeldicke und Spitzenform bei Bestellung angeben.**
Needle size and style of point to be stated on order.
Préciser la grosseur de l'aiguille et la forme de la pointe à la commande.
Grosor de aguja y forma de la punta, indíquese en los pedidos.
- 27/5** **Eingeklammerte Zahl = Länge in mm.**
Number in brackets = length in mm.
Chiffre entre parenthèses = longueur en mm.
Cifra entre paréntesis = largura en mm.
- 40/1** **Füllen mit 28-011 201-44; Bestellnummer siehe Seite 18 - 1.**
Top up with 28-011 201-44; for part number see page 18 - 1.
Remplir de 28-011 201-44; n° de commande, voir page 18 - 1.
Rellene con 28-011 201-44; para el número de pedido véase la página 18 - 1.
- 40/2** **Tränken mit 28-011 201-44; Bestellnummer siehe Seite 18 - 1.**
Grease with 28-011 201-44; for part number see page 18 - 1.
Graisser avec de la graisse 28-011 201-44; n° de commande, voir page 18 - 1.
Engrase con grasa 28-011 201-44; para el número de pedido véase la página 18 - 1.
- 40/3** **Fetten mit 28-011 202-47; Bestellnummer siehe Seite 18 - 1.**
Grease with 28-011 202-47; for part number see page 18 - 1.
Graisser avec de la graisse 28-011 202-47; n° de commande, voir page 18 - 1.
Engrase con grasa 28-011 202-47; para el número de pedido véase la página 18 - 1.
- 40/4** **Fetten mit 28-011 202-43; Bestellnummer siehe Seite 18 - 1.**
Grease with 28-011 202-43; for part number see page 18 - 1.
Graisser avec de la graisse 28-011 202-43; n° de commande, voir page 18 - 1.
Engrase con grasa 28-011 202-43; para el número de pedido véase la página 18 - 1.

40/29

Fetten mit 28-011 202-10; Bestellnummer siehe Seite 18 - 1.
Grease with 28-011 202-10; for part number see page 18 - 1.
Graisser avec de la graisse 28-011 202-10; n° de commande, voir page 18 - 1.
Engrase con grasa 28-011 202-10; para el número de pedido véase la página 18 - 1.

90/14

Für Hosen mit Kniefutter.
For trousers with knee-length lining.
Pour les pantalons avec doublure de genou.
Para pantalones con rodillas forradas.

96

Länge angeben.
State length.
Préciser longueur.
Indíquese la largura.

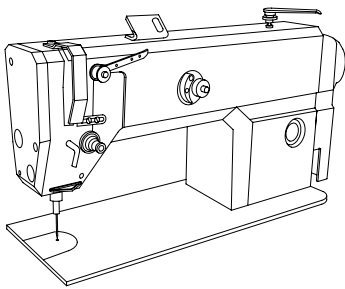

Gehäuseteile
 Housing sections
 Parties du corps
 Piezas del cárter

PFAFF 3586-12/02
 PFAFF 3586-13/01

3.01

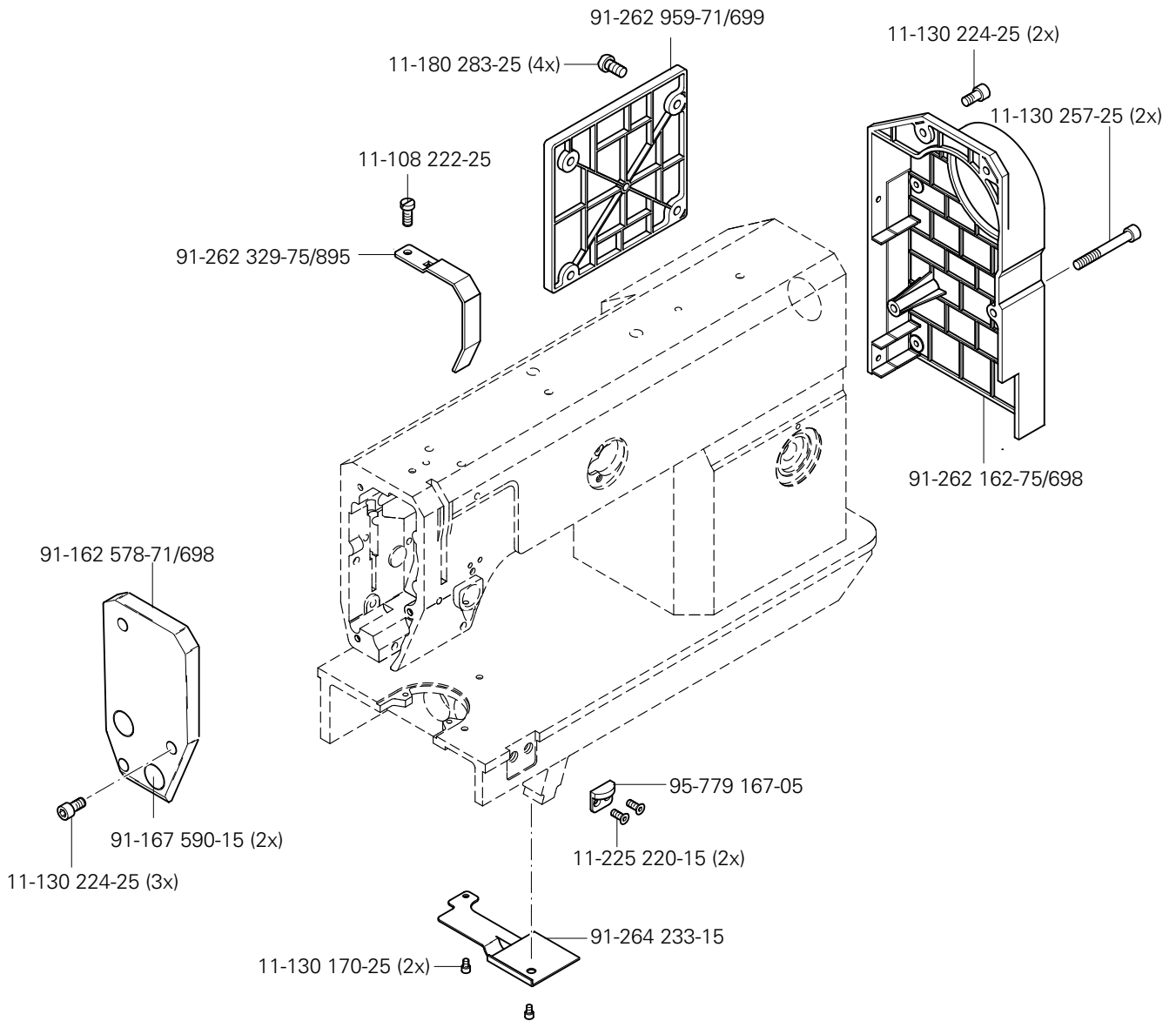

3.02

Kopfteile
Needle head parts
Pièces de tête
Piezas de la cabeza

PFAFF 3586-12/02
PFAFF 3586-13/01

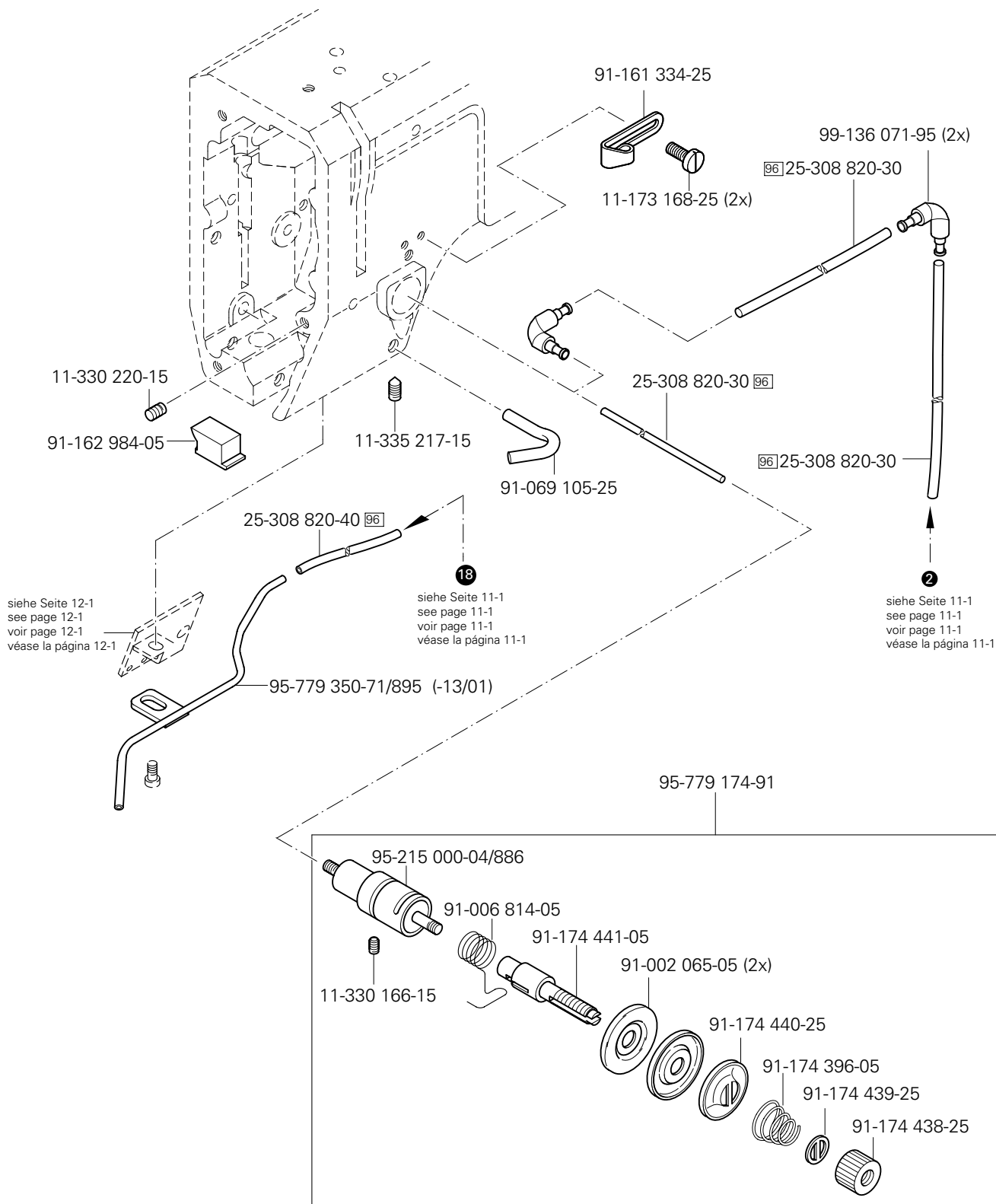
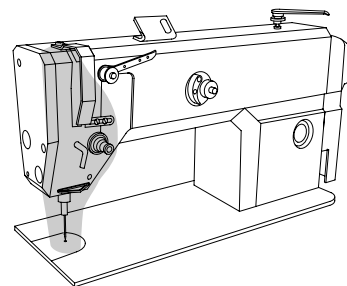

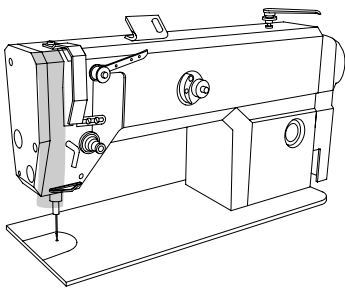

Kopfteile
Needle head parts
Pièces de tête
Piezas de la cabeza

PFAFF 3586-12/02
PFAFF 3586-13/01

3.02

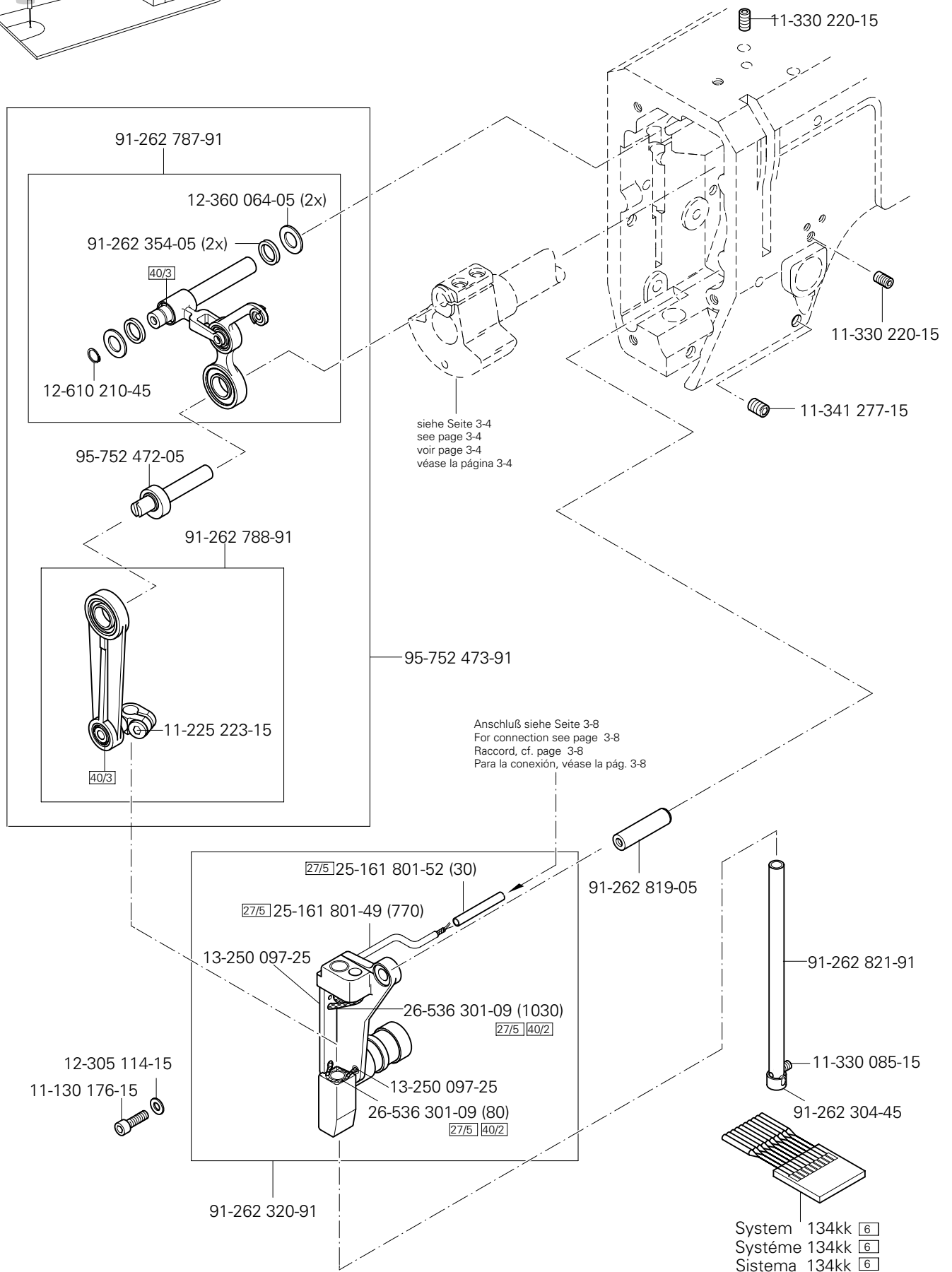

☐ siehe Kapitel 2 Erläuterung der Schlüsselzeichen
see chapter 2 Explanation of key markings
voir le chap. 2 Explication des symboles
véase el Cap. 2 Explicaciones de los signos clave

3.03

Armteile
 Arm parts
 Pièces de bras
 Piezas del brazo

PFAFF 3586-12/02
 PFAFF 3586-13/01

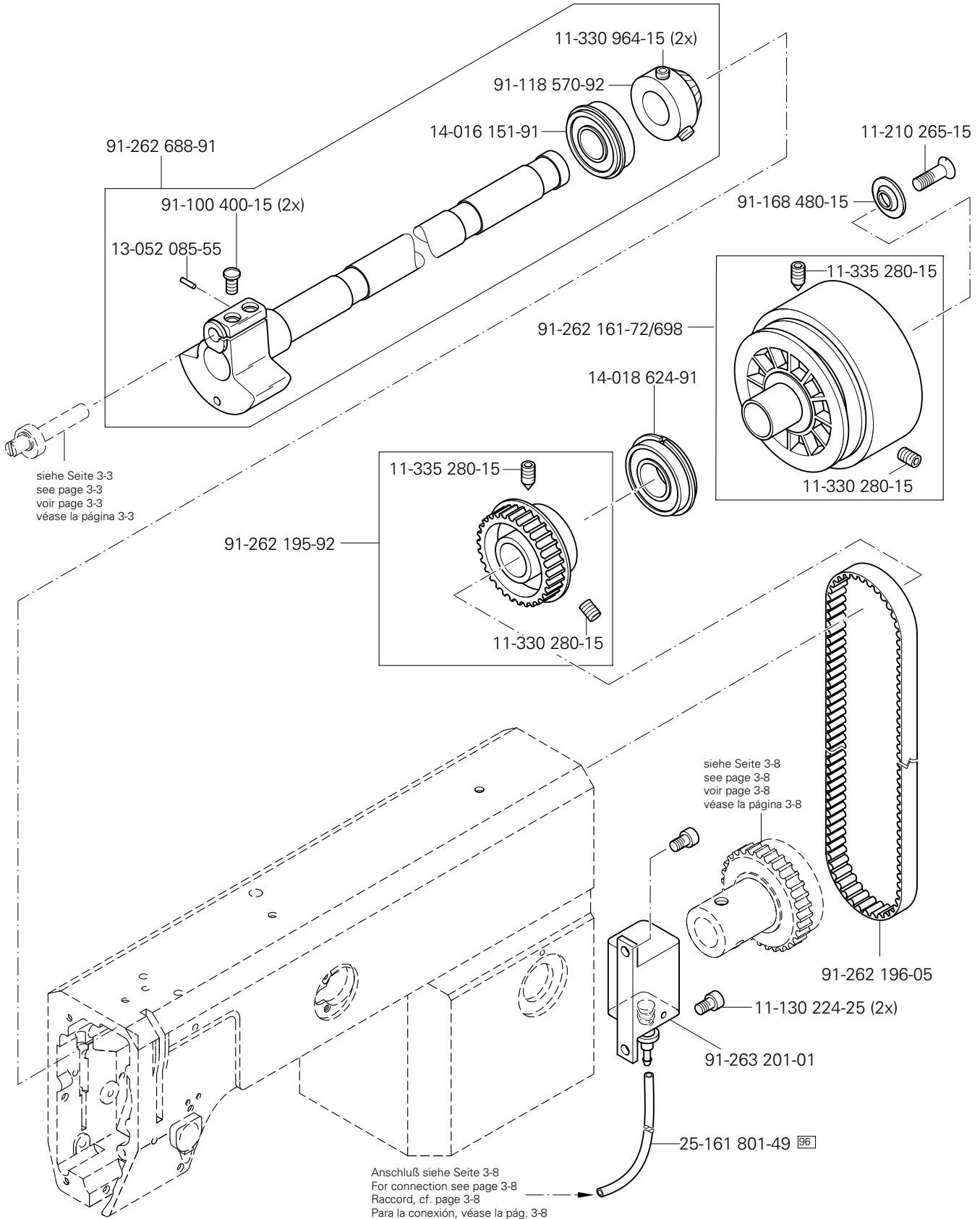
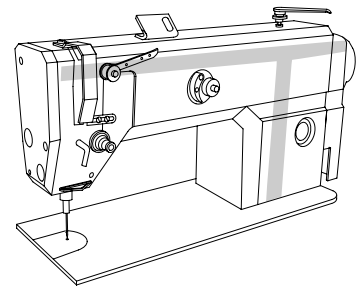

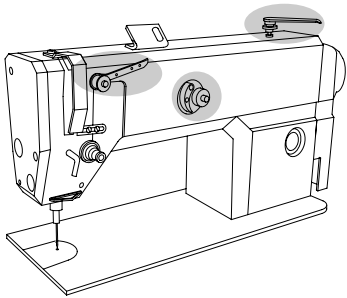

Armteile

Arm parts

Pièces de bras

PFAFF 3586-12/02

Piezas del brazo

PFAFF 3586-13/01

3.03

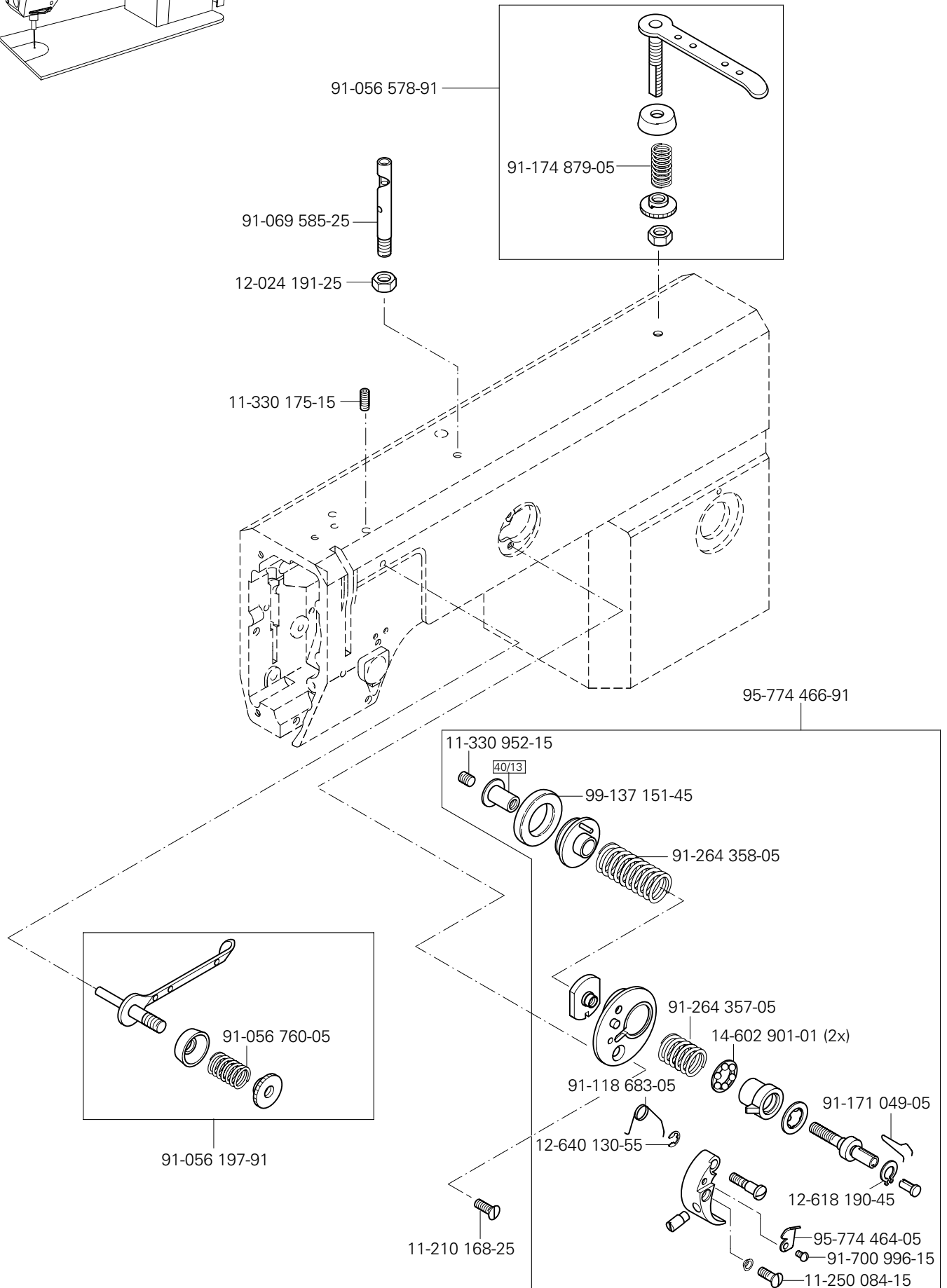



 siehe Kapitel 2 Erläuterung der Schlüsselzeichen
 see chapter 2 Explanation of key markings
 voir le chap. 2 Explication des symboles
 véase el Cap. 2 Explicaciones de los signos clave

3.04

Grundplattenteile
Bedplate parts
Pièces du plateau fondamental
Piezas del cárter

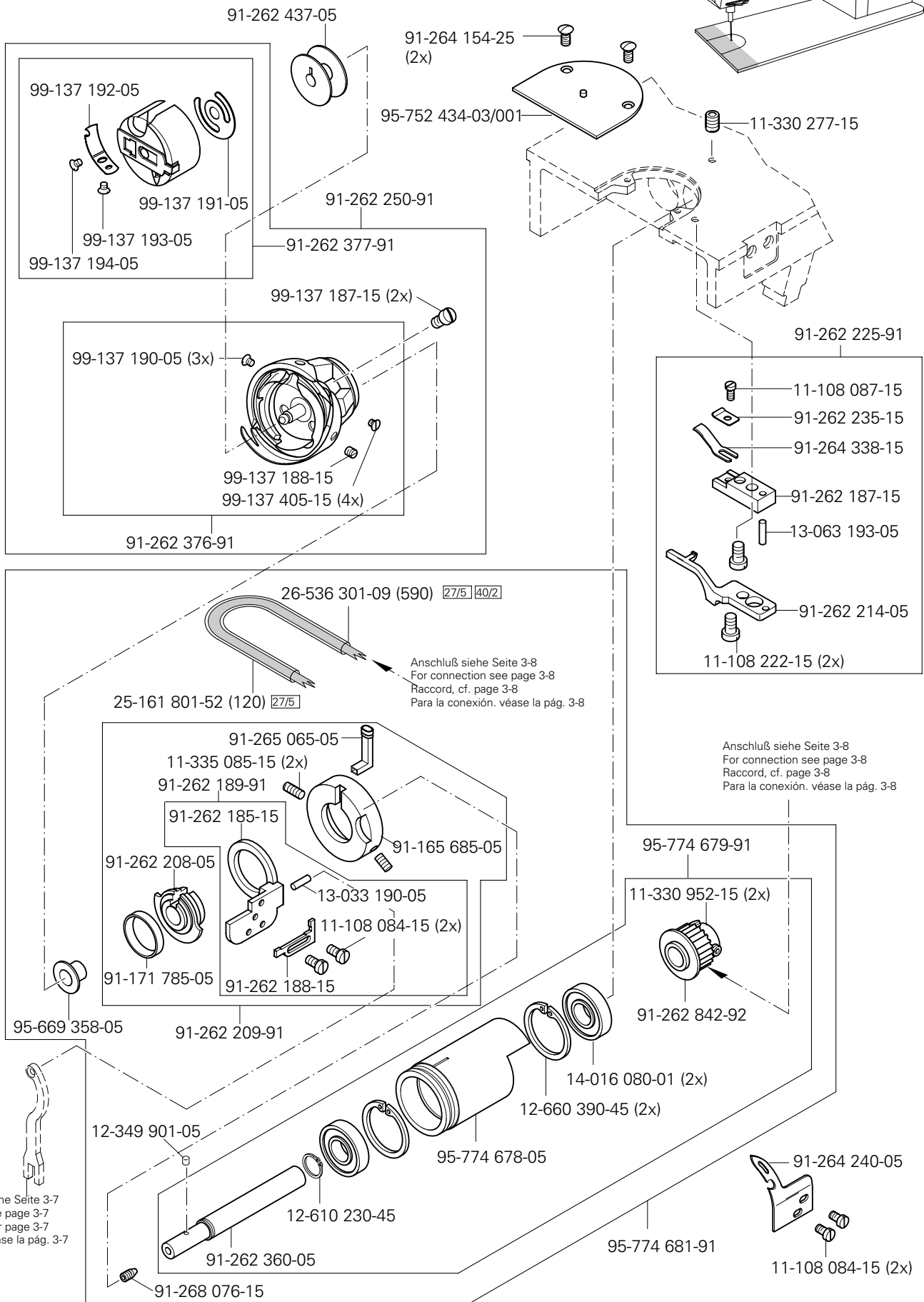
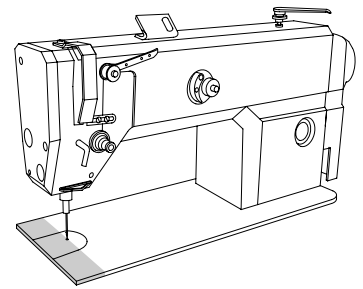
PFAFF 3586-12/02
PFAFF 3586-13/01



siehe Seite 3-7
see page 3-7
voir page 3-7
véase la pág. 3-7

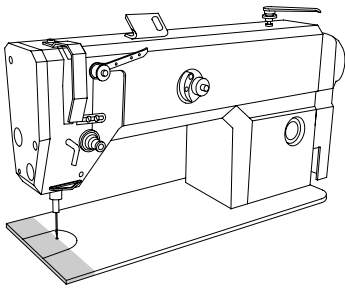

Grundplattenteile

Bedplate parts

Pièces du plateau fondamental

Piezas del cárter

PFAFF 3586-12/02

PFAFF 3586-13/01

3.04

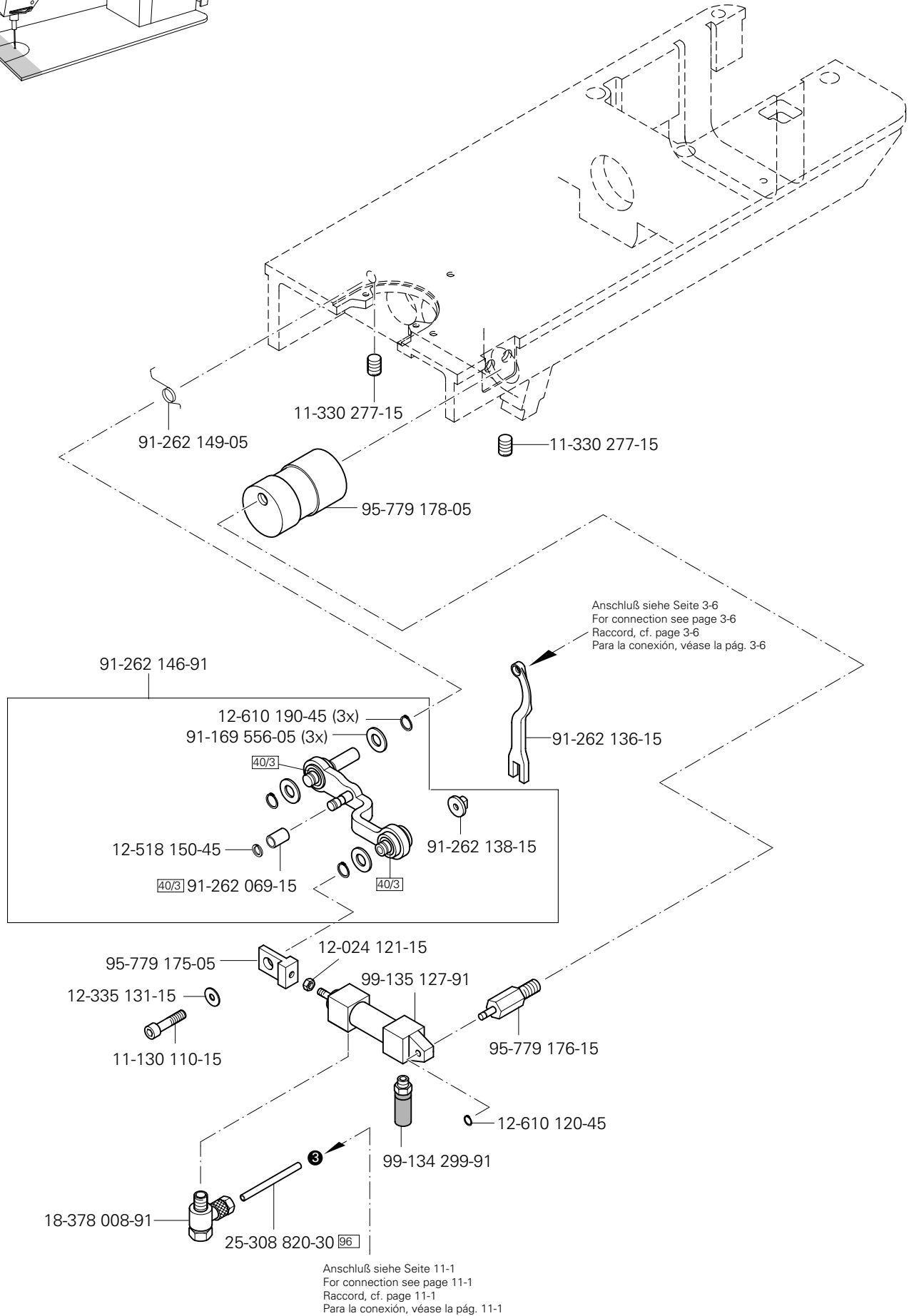

3.04

Grundplattenteile Bedplate parts Pièces du plateau fondamental Piezas del cárter

PFAFF 3586-12/02
PFAFF 3586-13/01

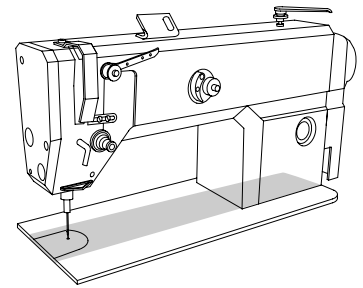

siehe Seite 3-4
see page 3-4
voir page 3-4
véase la página 3-4

Anschluß siehe Seite 12-2
For connection see page 12-2
Raccord, cf. page 12-2
Para la conexión, véase la pág. 12-2

91-262 566-92

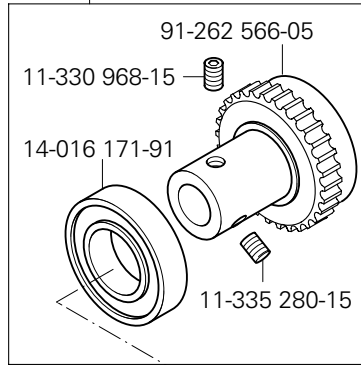

91-262 566-05

11-330 968-15

14-016 171-91

11-335 280-15

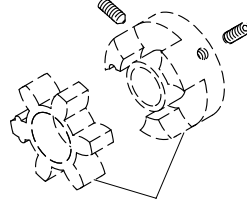

siehe Seite 12-2
see page 12-2
voir page 12-2
véase la página 12-2

siehe Seite 3-3
see page 3-3
voir page 3-3
véase la página 3-3

siehe Seite 3-3
see page 3-3
voir page 3-3
véase la página 3-3

91-262 061-05

11-330 964-15 (2x)

91-262 844-92

14-016 101-91

11-330 952-15 (2x)

12-610 250-45

siehe Seite 3-6
see page 3-6
voir page 3-6
véase la página 3-6

12-610 250-45

16-409 983-05

91-262 062-92

95-744 686-01

Anschluß siehe Seite 3-4
For connection see page 3-4
Raccord, cf. page 3-4
Para la conexión, véase la pág. 3-4

91-262 845-91

siehe Seite 3-6
see page 3-6
voir page 3-6
véase la página 3-6

11-108 177-15 (2x)

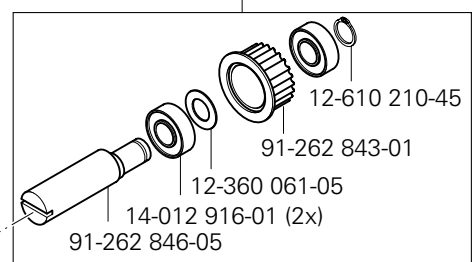

12-610 210-45

91-262 843-01

12-360 061-05

14-012 916-01 (2x)

91-262 846-05

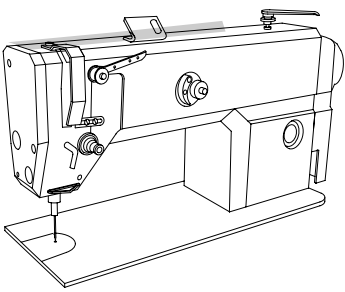

Y-Antrieb

Y drive

Système de commande Y

PFAFF 3586-12/02

Grupo de accionamiento „Y“

PFAFF 3586-13/01

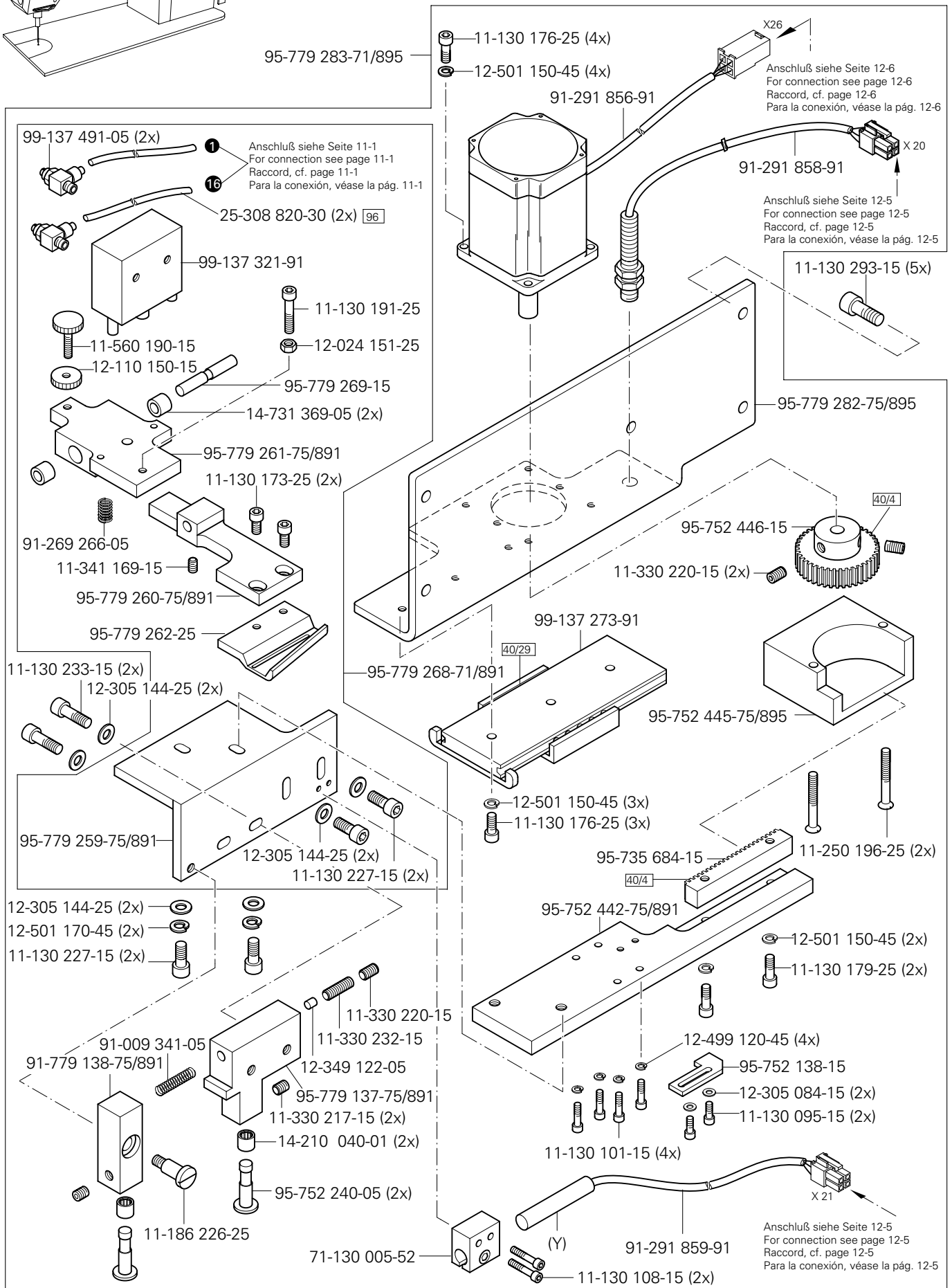

siehe Kapitel 2 Erläuterung der Schlüsselzeichen
 see chapter 2 Explanation of key markings
 voir le chap. 2 Explication des symboles
 véase el Cap. 2 Explicaciones de los signos clave

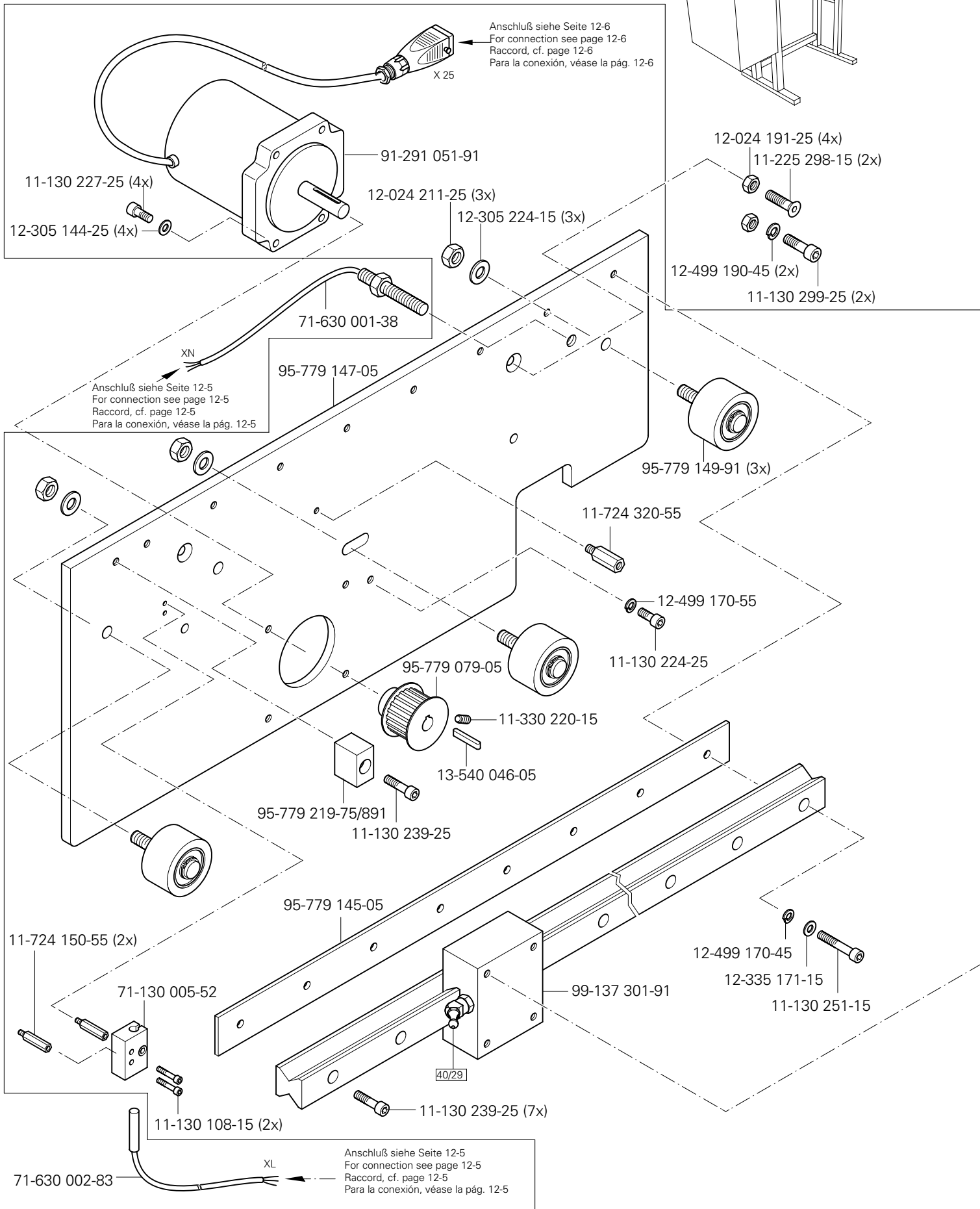
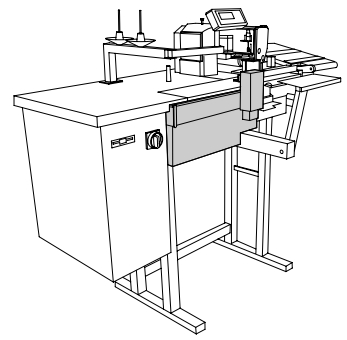

X-Antrieb
 X drive
 Système de commande X
 Grupo de accionamiento „X“

PFAFF 3586-12/02
 PFAFF 3586-13/01

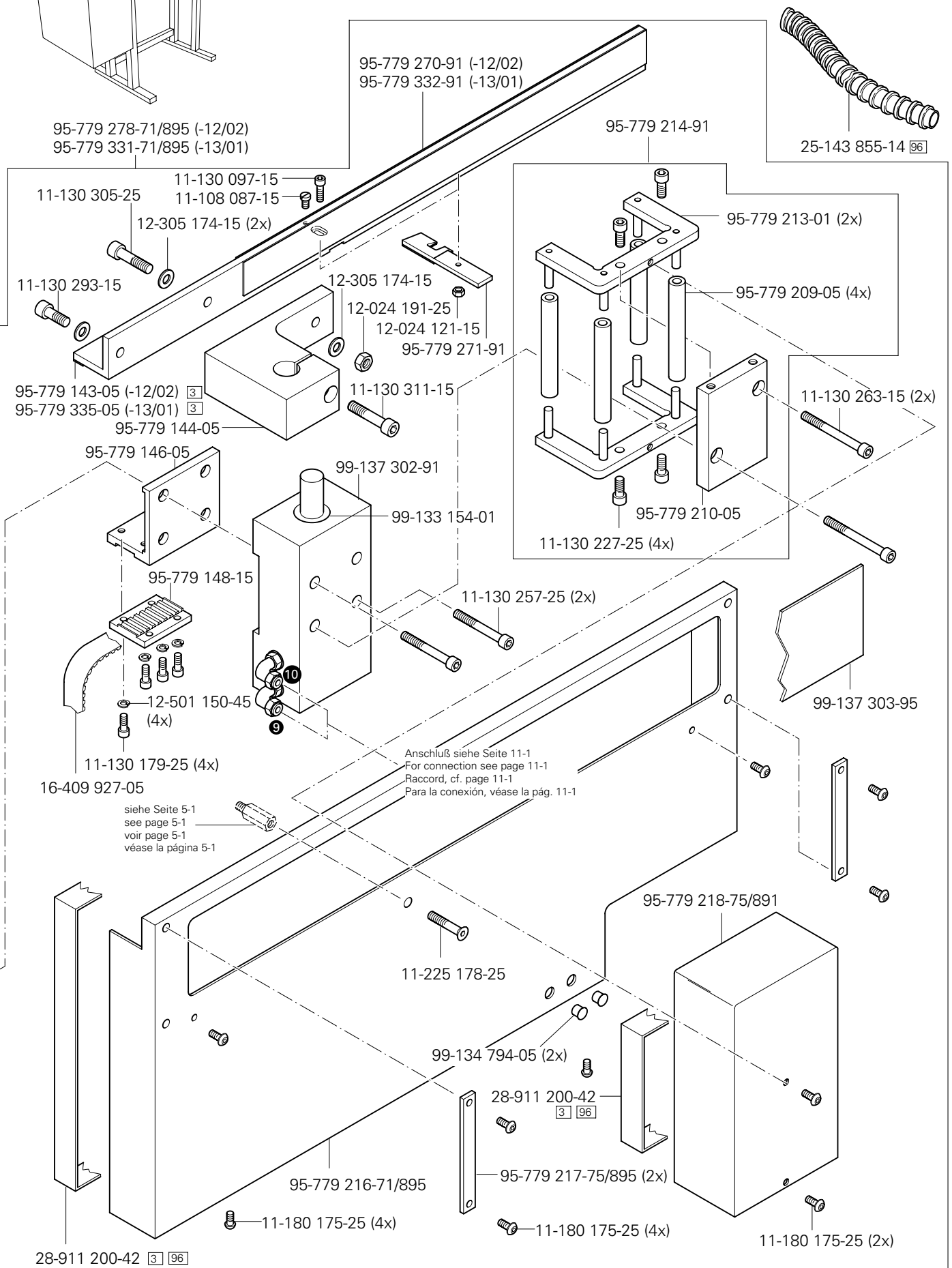

☐ siehe Kapitel 2 Erläuterung der Schlüsselzeichen
 see chapter 2 Explanation of key markings
 voir le chap. 2 Explication des symboles
 véase el Cap. 2 Explicaciones de los signos clave

6

Abdeckplatte vorn

Front cover plate

Plaque de recouvrement avant

Placa de cubrimiento delantera

PFAFF 3586-12/02

PFAFF 3586-13/01

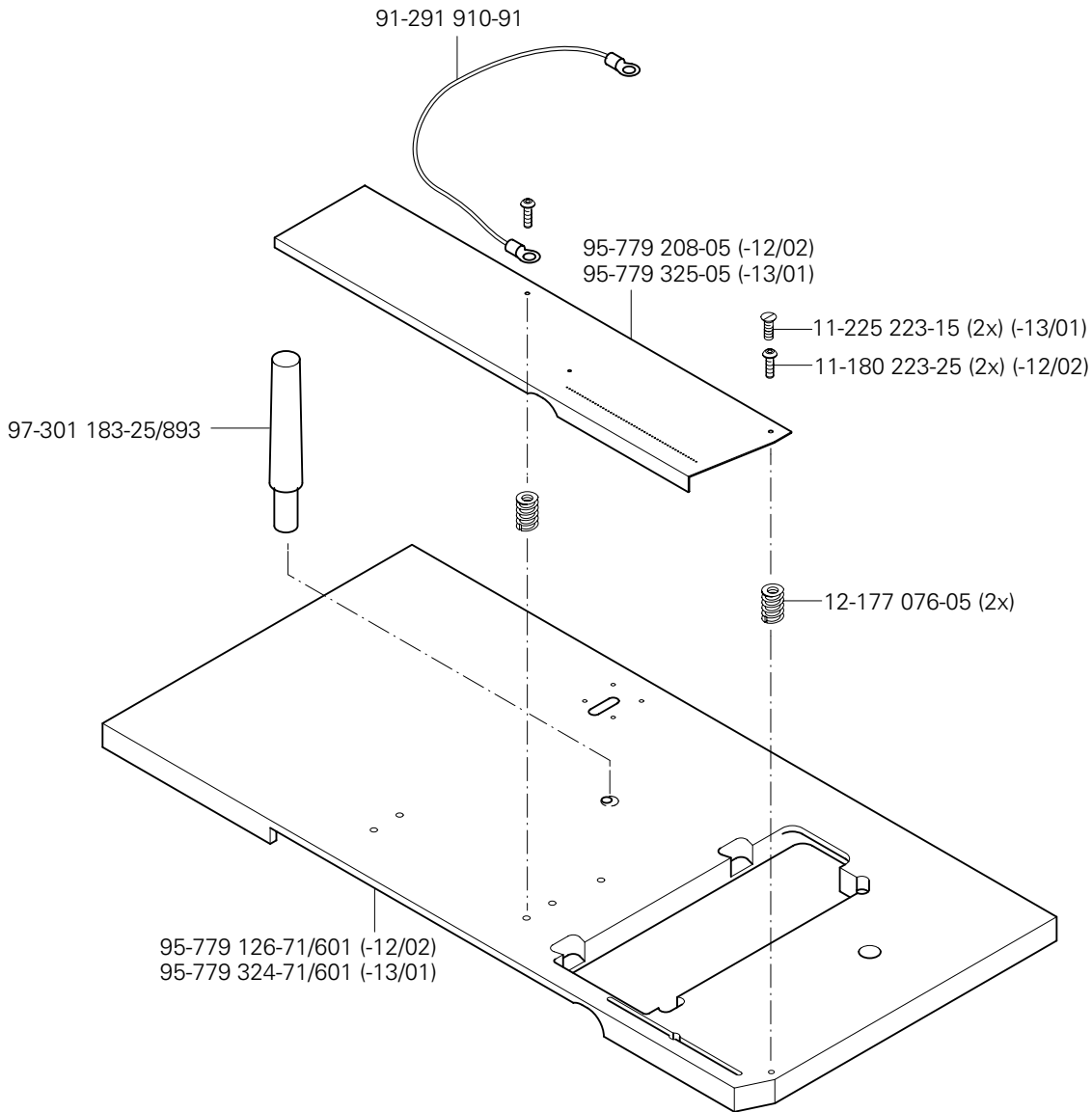
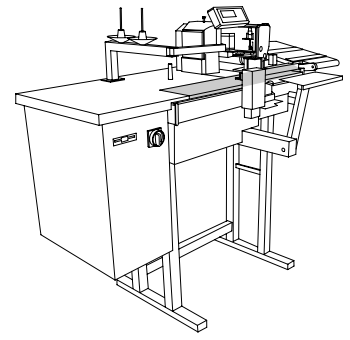

Stoffübernahme
Material take-over unit
Pince-ouvrage
Sujetatelas

PFAFF 3586-12/02

7

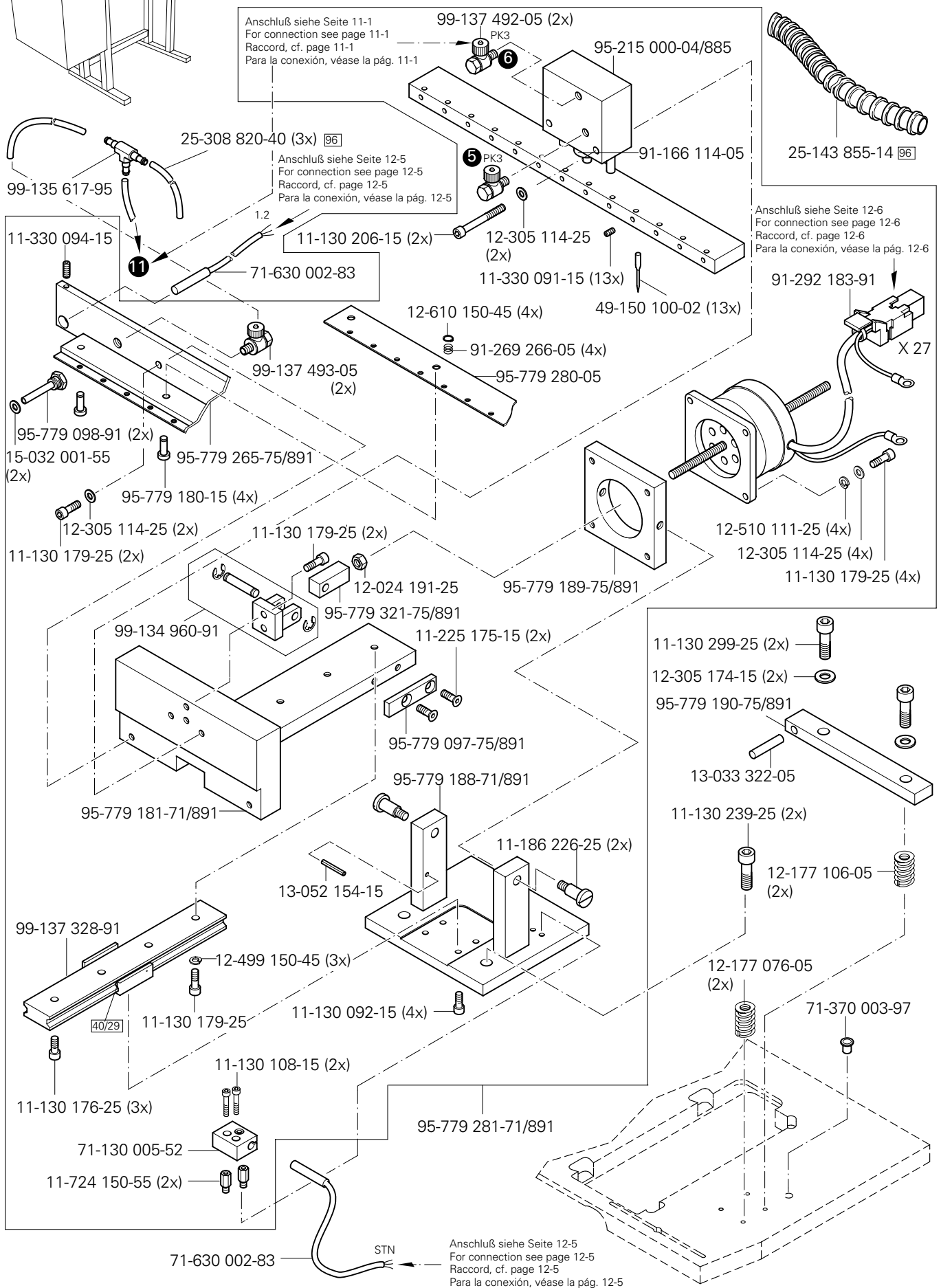
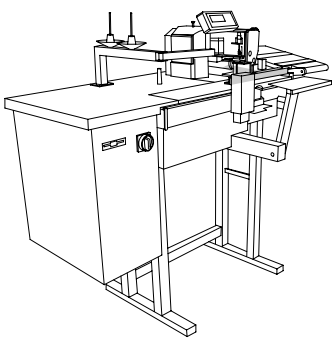

siehe Kapitel 2 Erläuterung der Schlüsselzeichen
 see chapter 2 Explanation of key markings
 voir le chap. 2 Explication des symboles
 véase el Cap. 2 Explicaciones de los signos clave

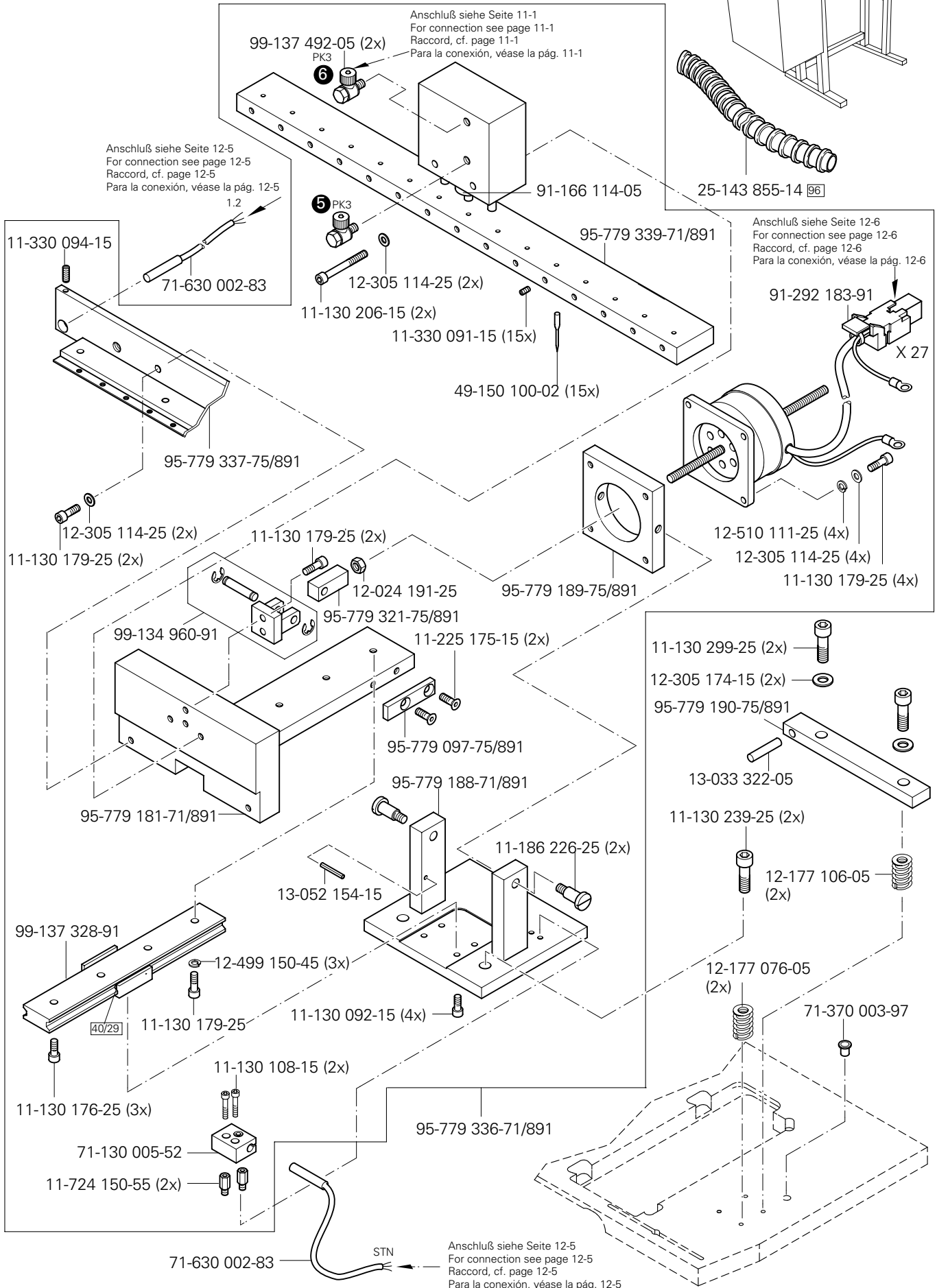
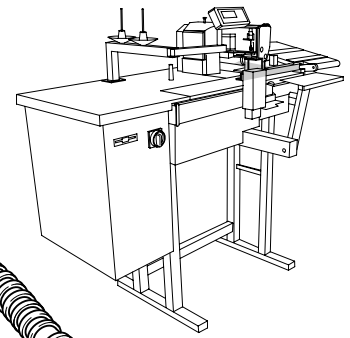

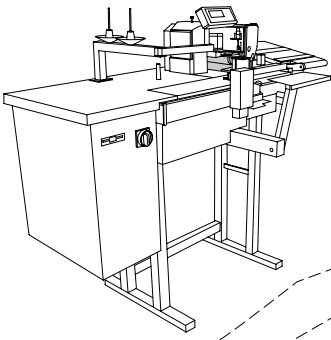

Ölfangwanne
 Oil drip pan
 Caster d'huile
 Bandeja colectora de acei

PFAFF 3586-12/02
 PFAFF 3586-13/01

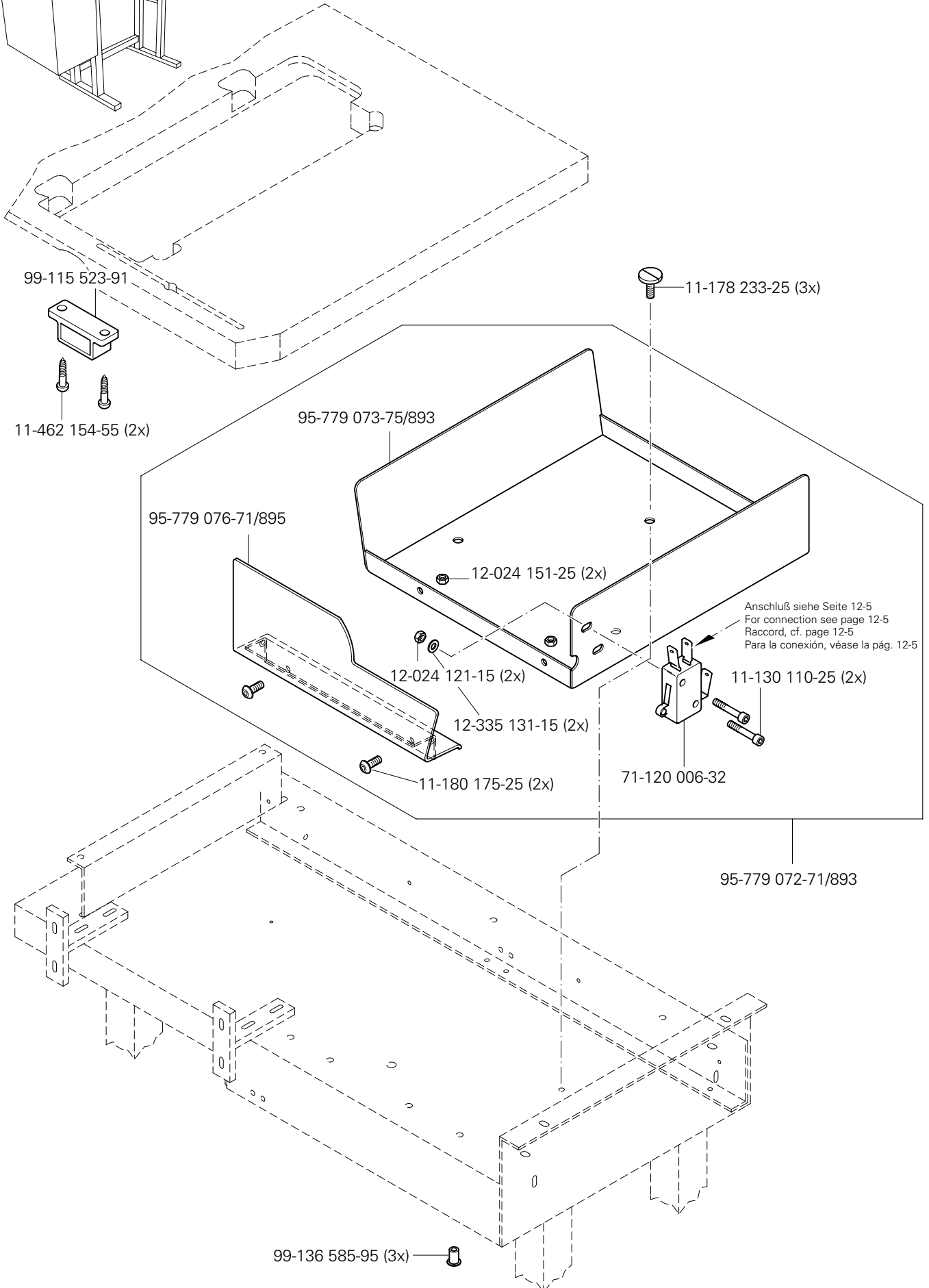

 siehe Kapitel 2 Erläuterung der Schlüsselzeichen
 see chapter 2 Explanation of key markings
 voir le chap. 2 Explication des symboles
 véase el Cap. 2 Explicaciones de los signos clave

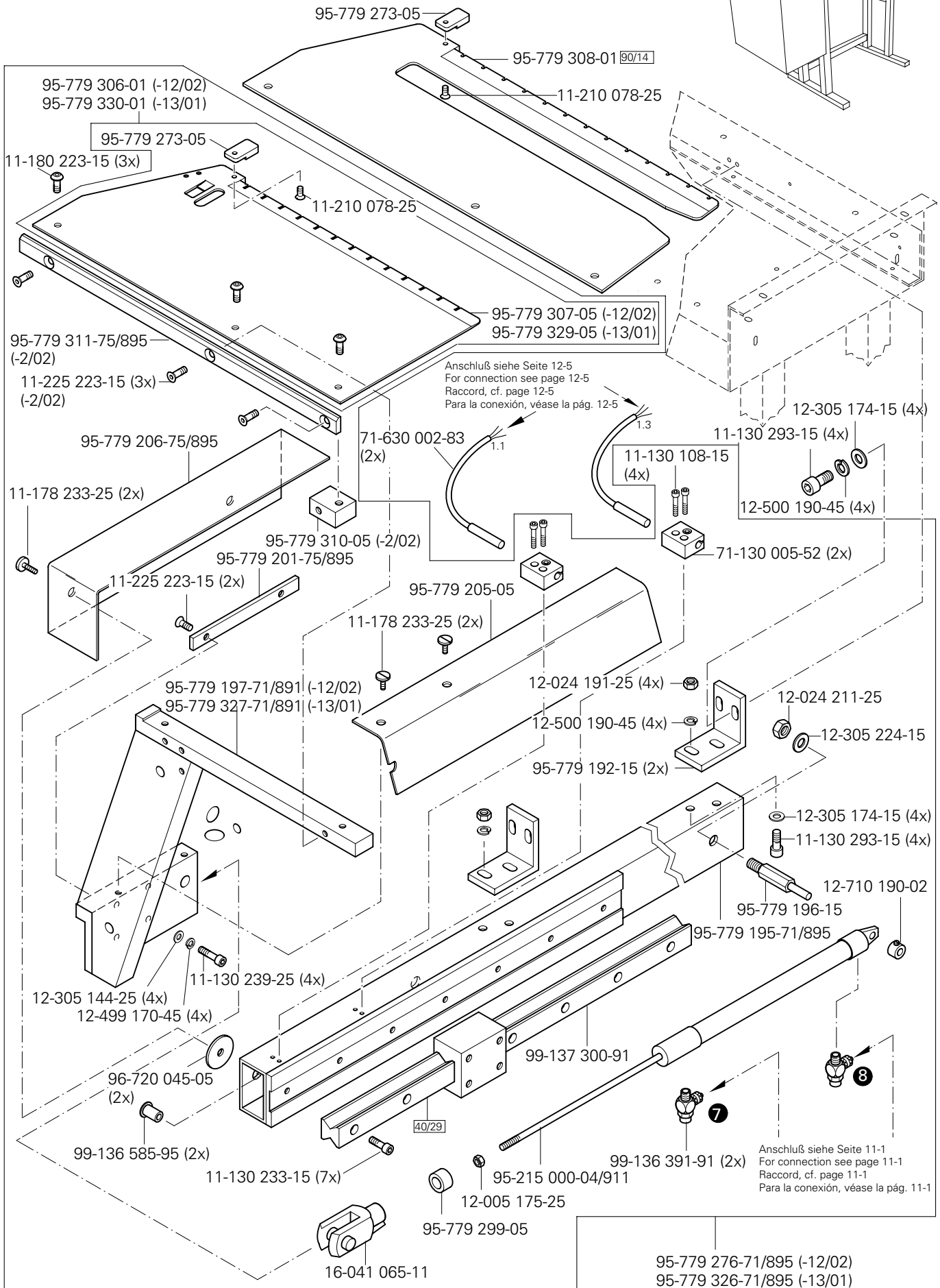
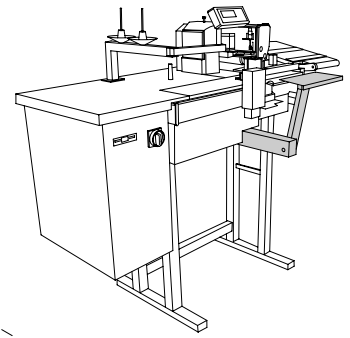

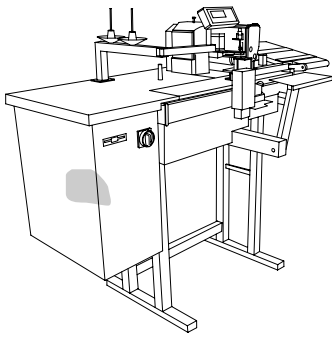

Wartungseinheit
 Air filter / lubricator
 Conditionneur d'air comprimé
 Grupo acondicionador del aire comprimido

PFAFF 3586-12/02
 PFAFF 3586-13/01

Anschluß siehe Seite 12-8
 For connection see page 12-8
 Raccord, cf. page 12-8
 Para la conexión, véase la pág. 12-8

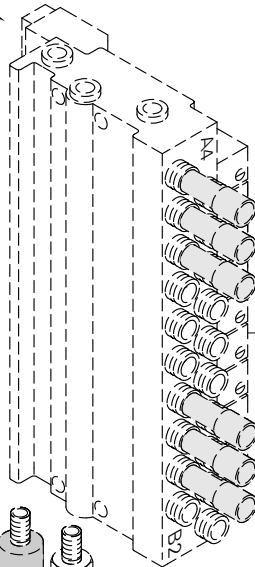

siehe Seite 11-1
 see page 11-1
 voir page 11-1
 véase la página 11-1

Anschluß siehe Seite 19-1
 For connection see page 19-1
 Raccord, cf. page 19-1
 Para la conexión, véase la pág. 19-1

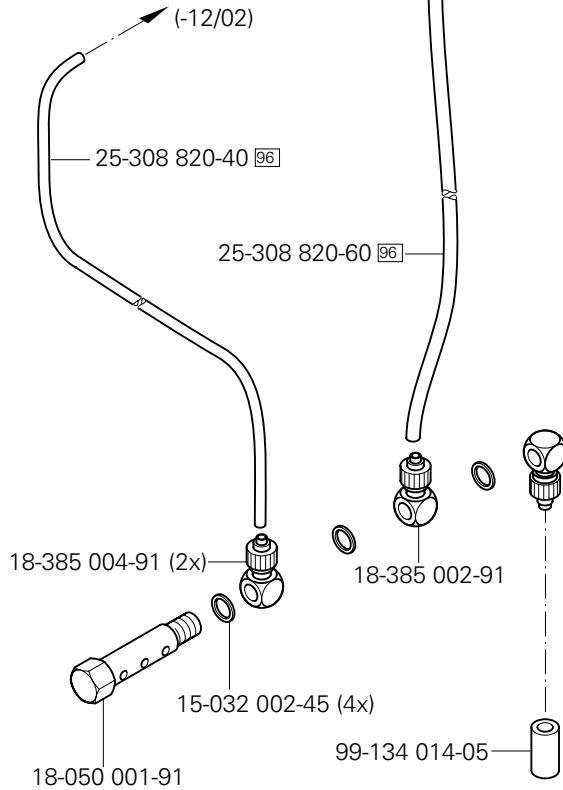

99-136 546-91

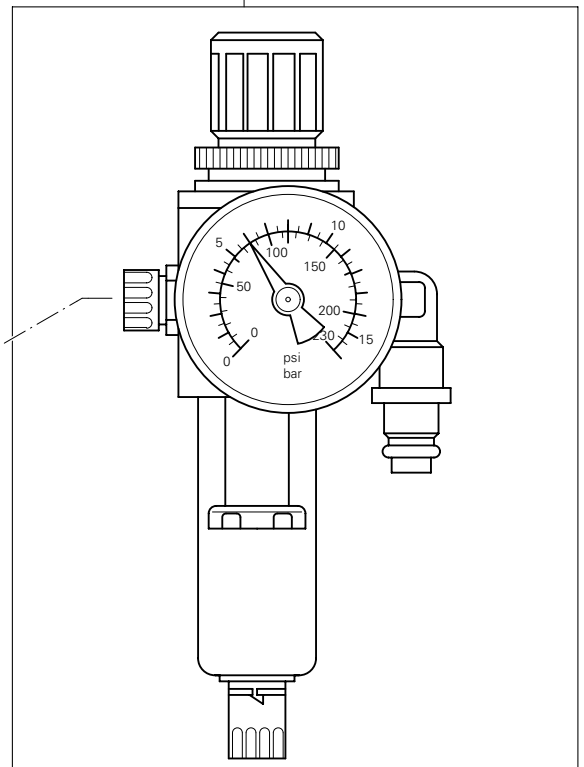

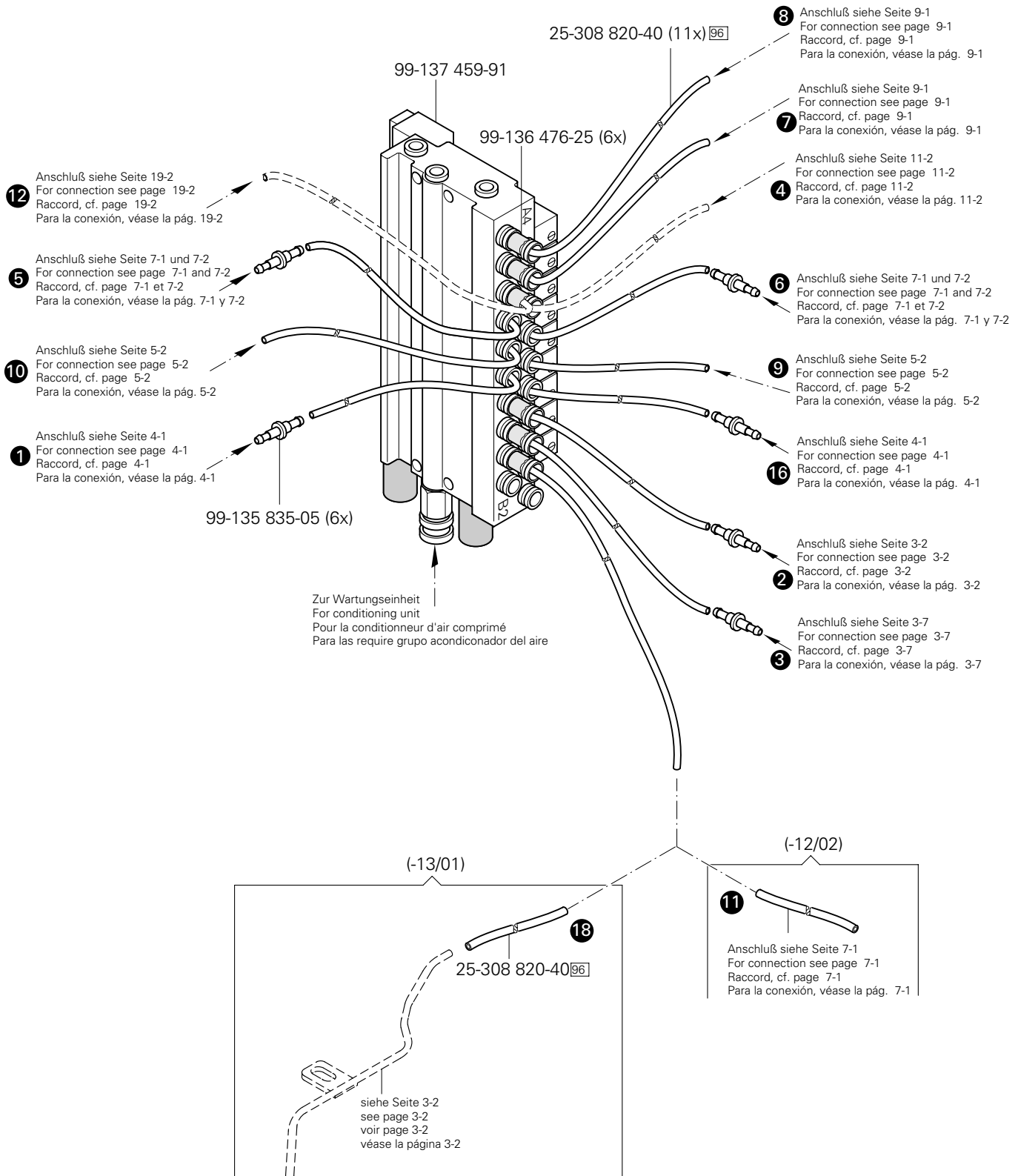
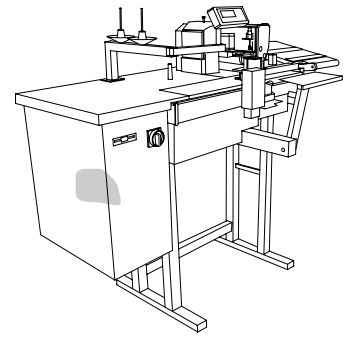

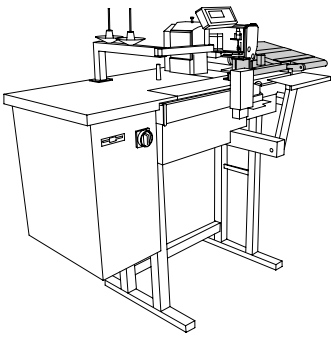

(-13/01)

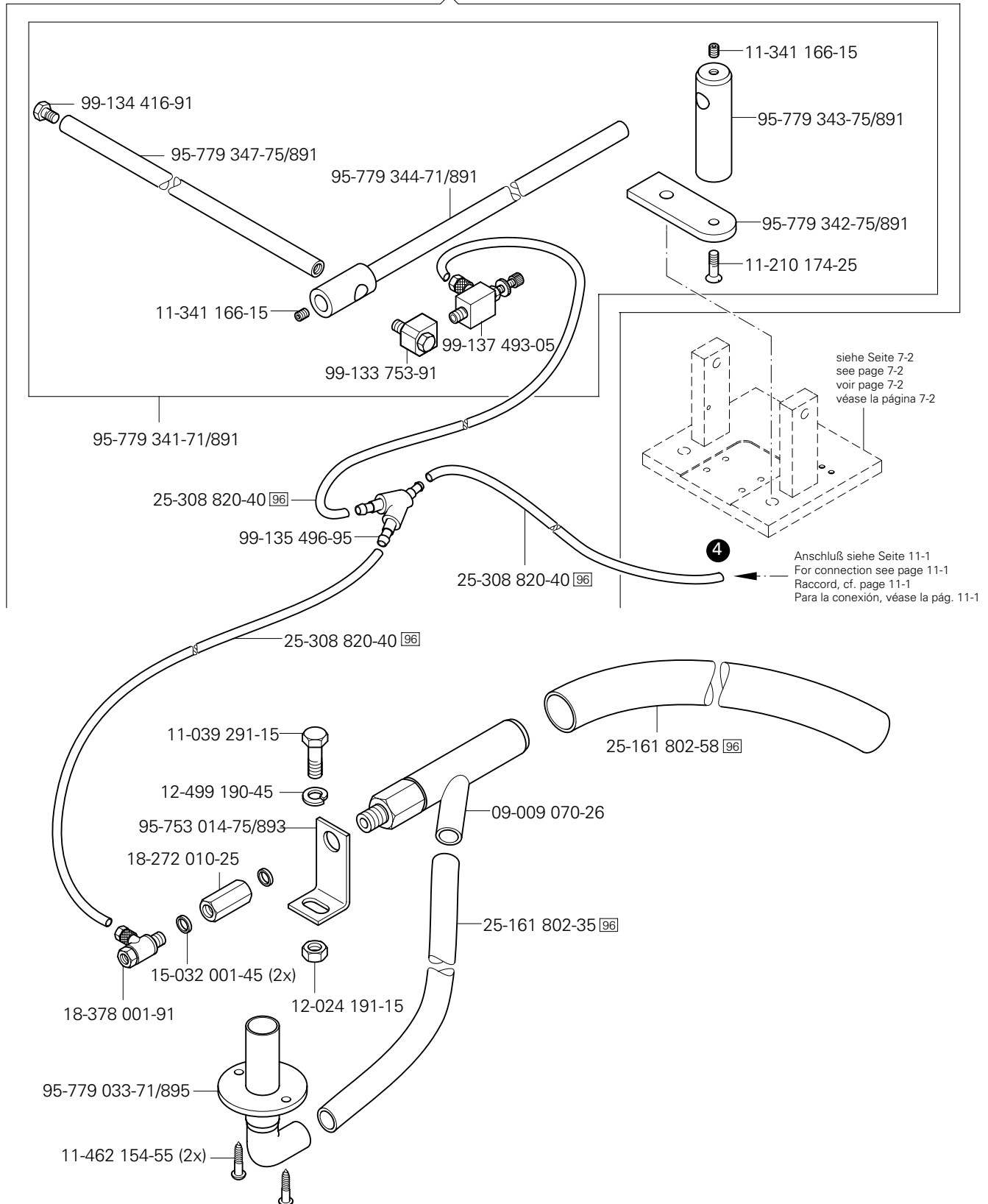

12.01

Fadenwächter
Thread monitors
Contrôleur de fil
Detector del hilo

PFAFF 3586-12/02
PFAFF 3586-13/01

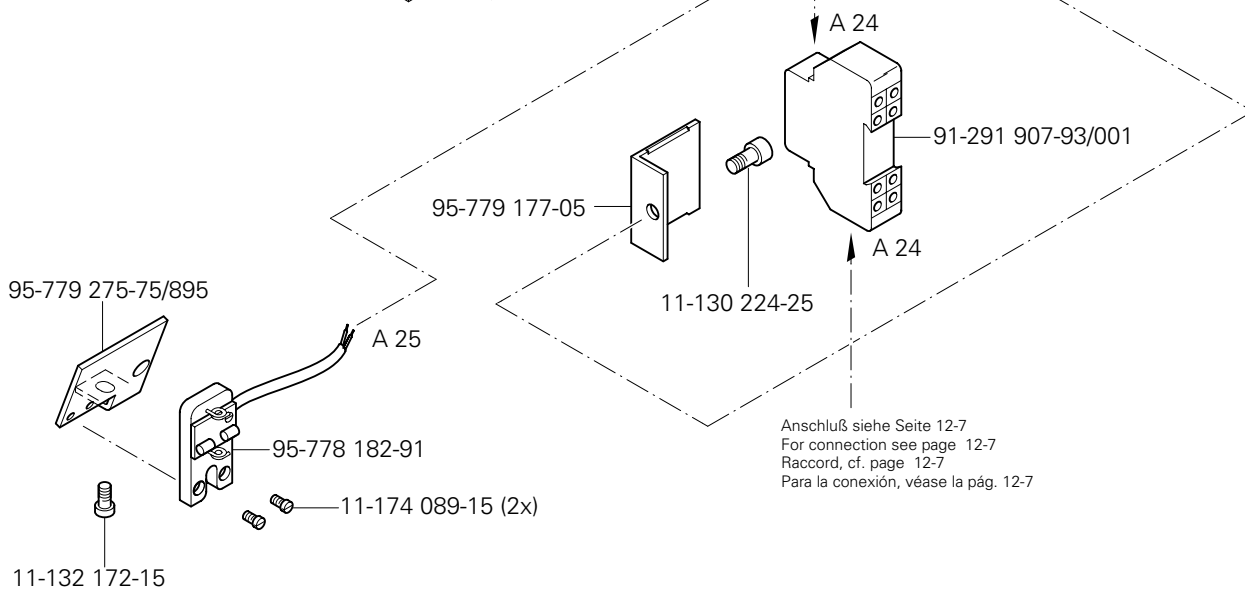
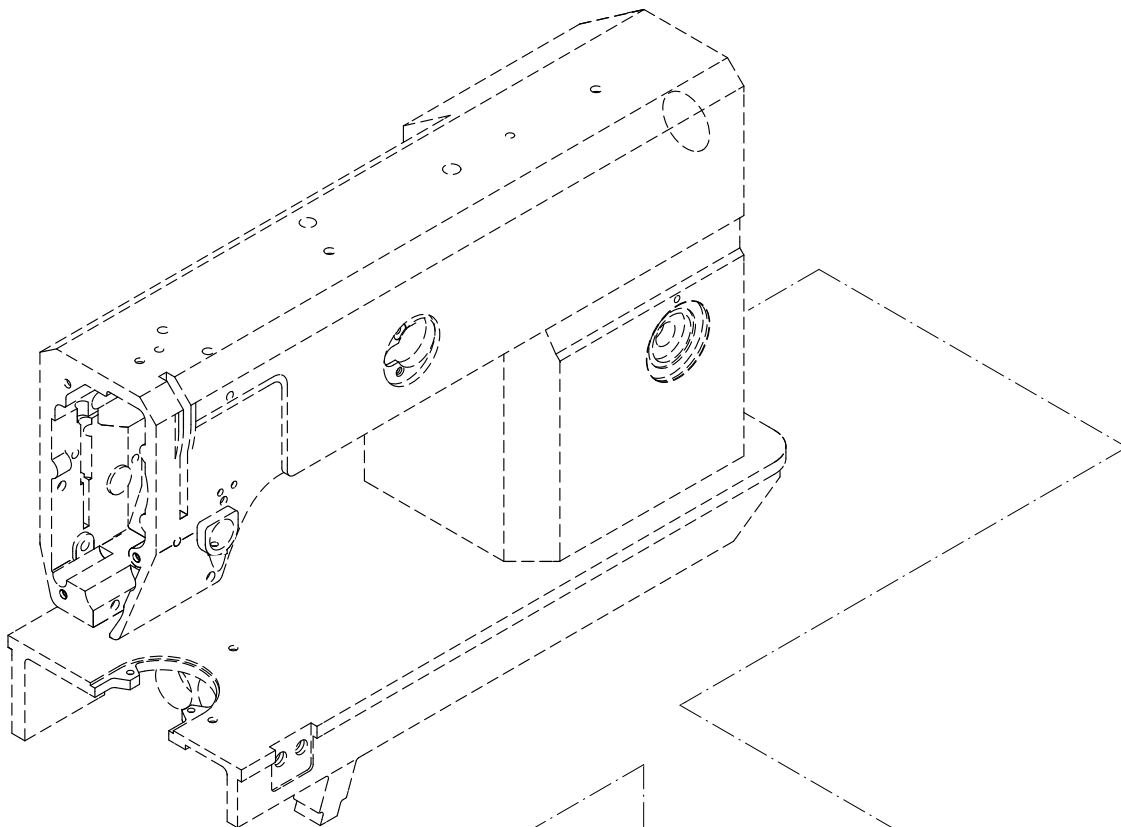
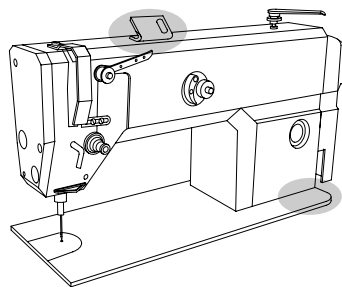

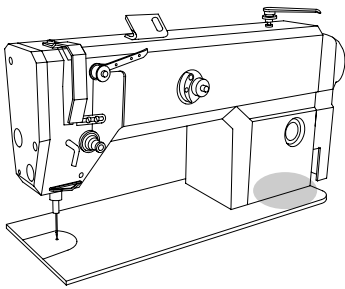

Einbaumotor
 Built-in motor
 Moteur incorporé
 Motor incorporado

PFAFF 3586-12/02
 PFAFF 3586-13/01

12.02

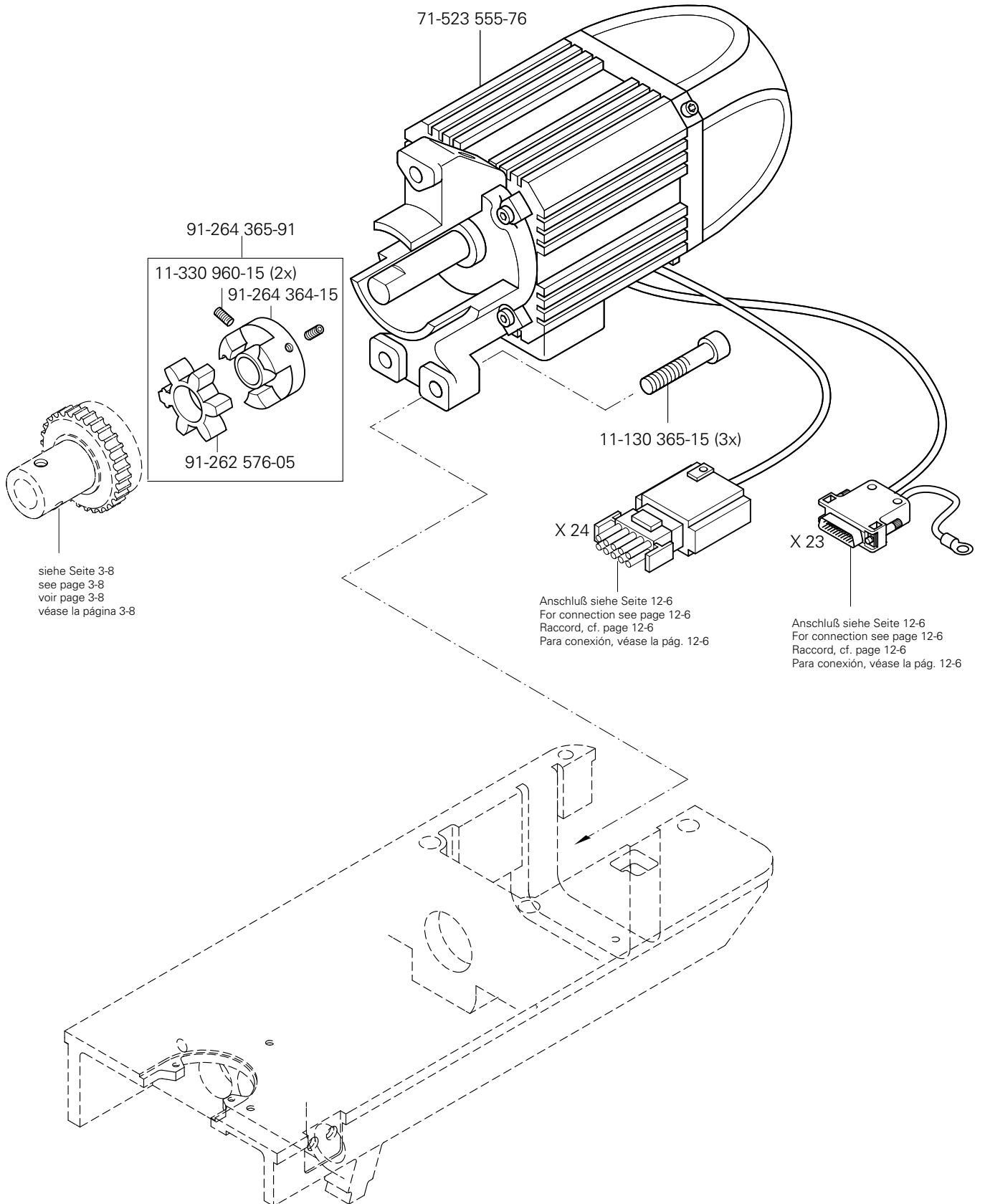

siehe Seite 3-8
 see page 3-8
 voir page 3-8
 véase la página 3-8

Anschluß siehe Seite 12-6
 For connection see page 12-6
 Raccord, cf. page 12-6
 Para conexión, véase la pág. 12-6

Anschluß siehe Seite 12-6
 For connection see page 12-6
 Raccord, cf. page 12-6
 Para conexión, véase la pág. 12-6

12.03

Bedienfeld
Control panel
Panneau de commande
Panel de mandos

PFAFF 3586-12/02
PFAFF 3586-13/01

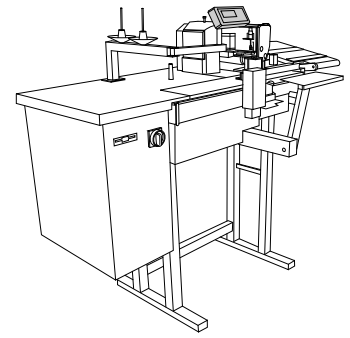

11-130 179-25 (4x)

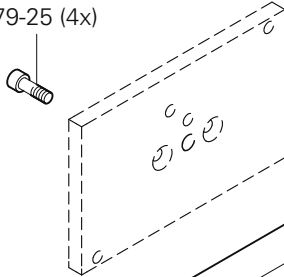

siehe Seite 14-1
see page 14-1
voir page 14-1
véase la página 14-1

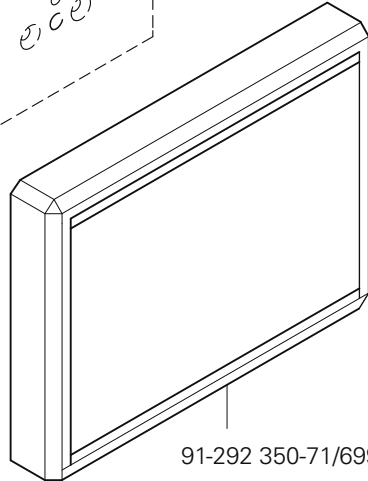

91-292 350-71/699

X 41

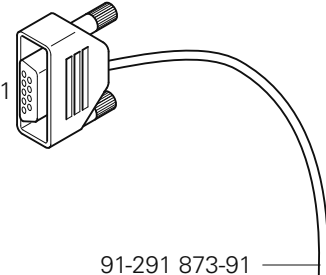

91-291 873-91

X 42

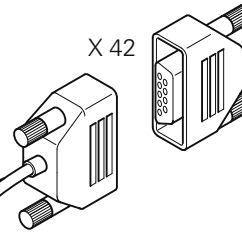

A 10 / X 300

siehe Seite 12-5
see page 12-5
voir page 12-5
véase la página 12-5

91-292 340-91

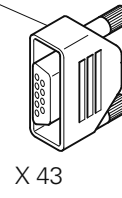

X 43

A 20 / X 101

Anschluß siehe Seite 12-7
For connection see page 12-7
Raccord, cf. page 12-7
Para la conexión, véase la pág. 12-7

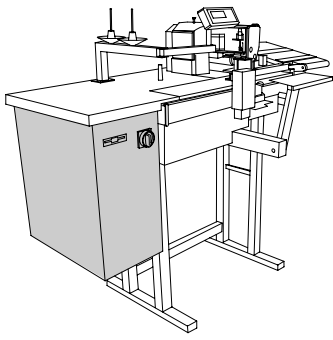

Steuergerät
Control device
Boîte de commande
Caja de mandos

PFAFF 3586-12/02
PFAFF 3586-13/01

12.04

Anschluß siehe Seite 12-7
For connection see page 12-7
Raccord, cf. page 12-7
Para la conexión, véase la pág. 12-7

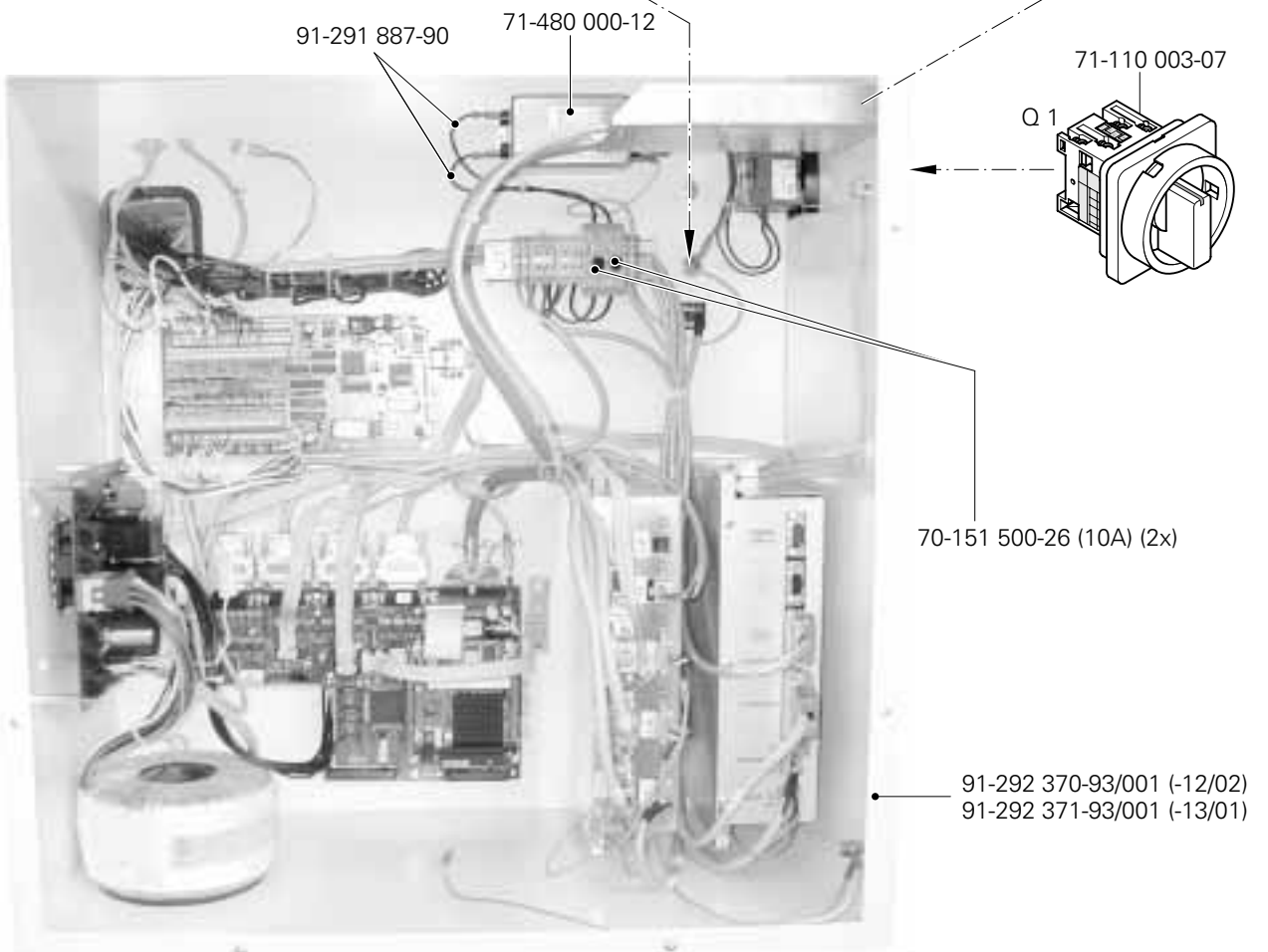
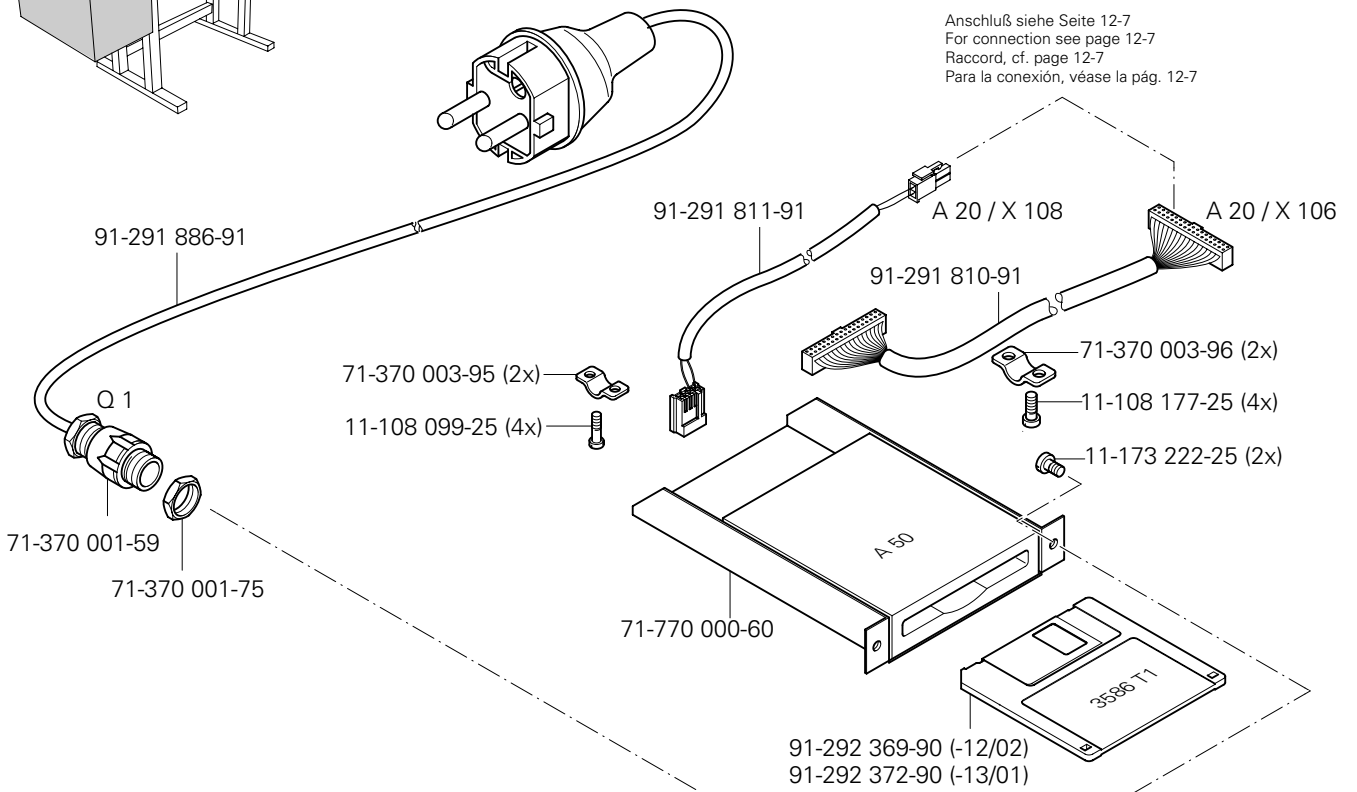

12.04

Steuergerät
Control device
Boîte de commande
Caja de mandos

PFAFF 3586-12/02
PFAFF 3586-13/01

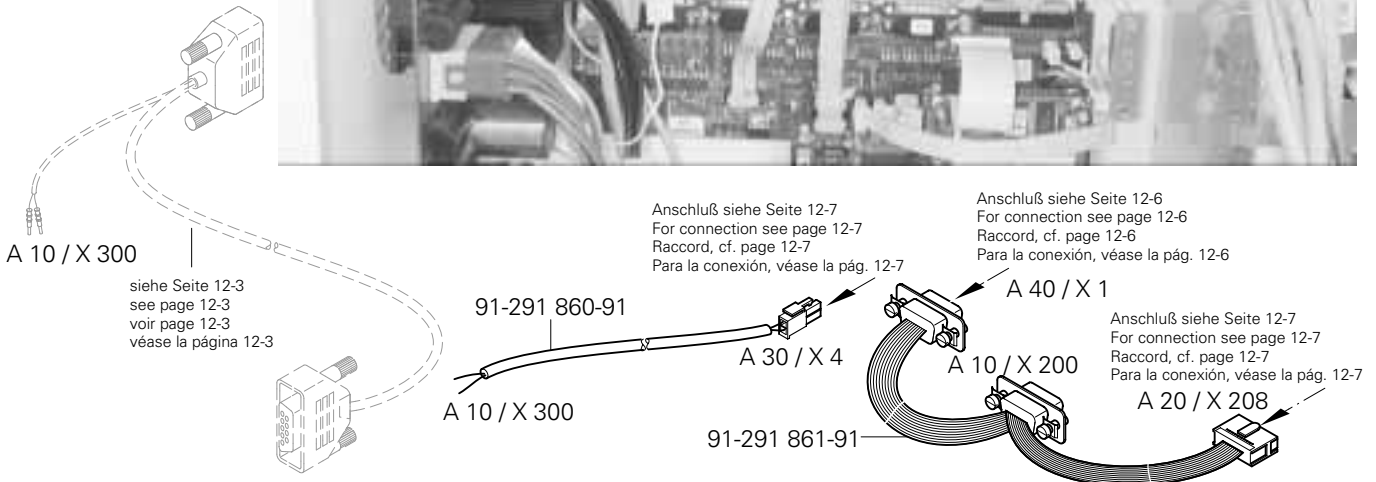
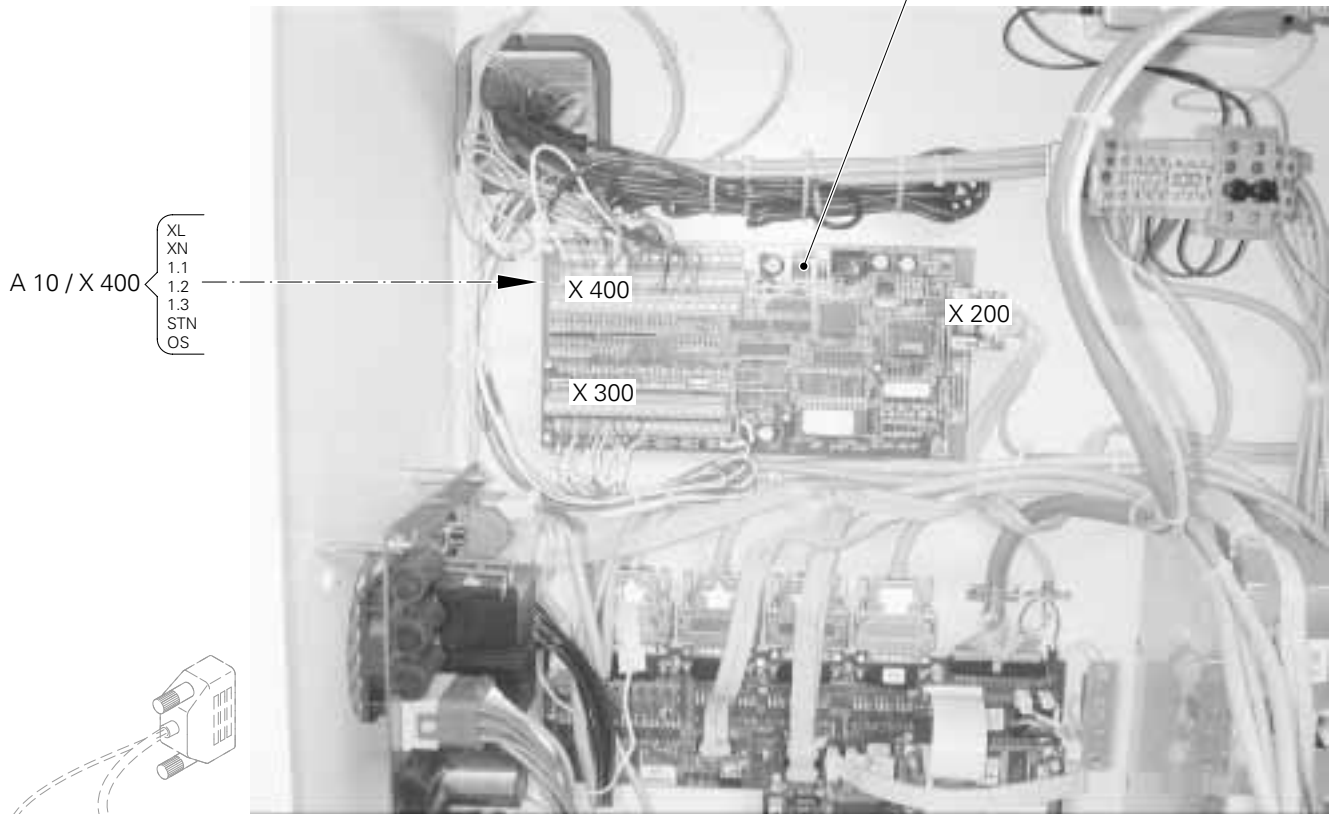
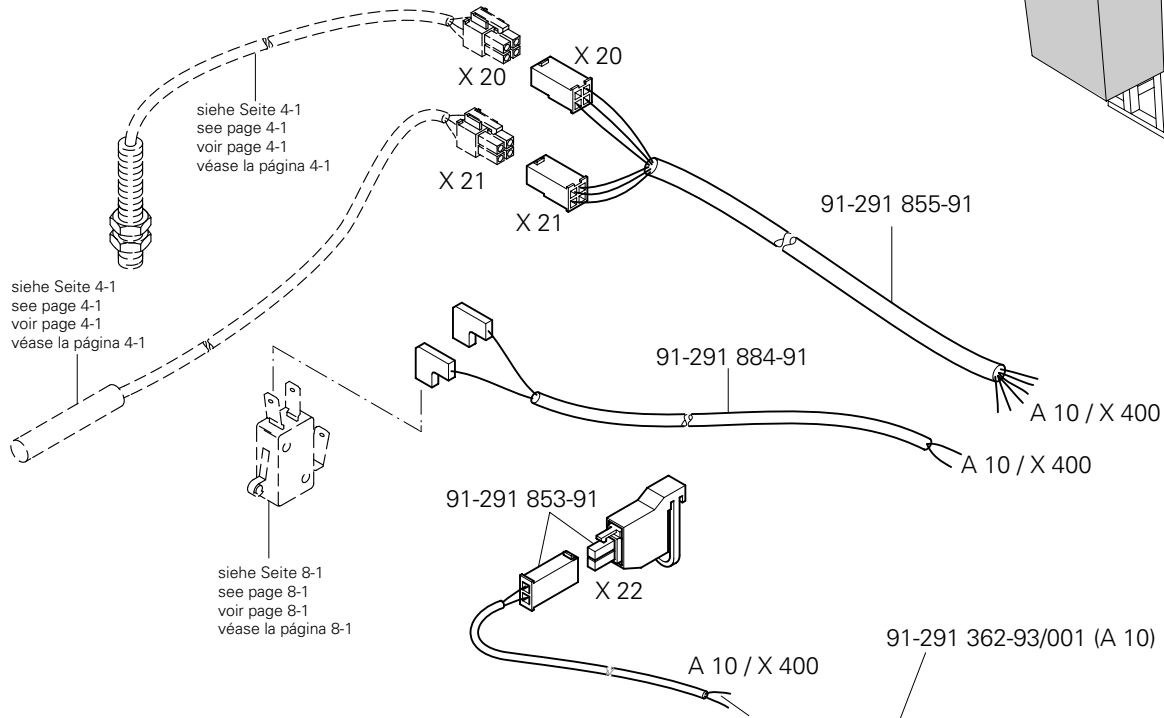
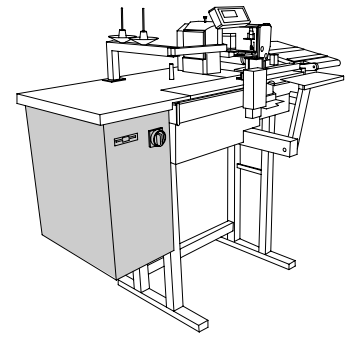

Steuergerät
Control device
Boîte de commande
Caja de mandos

PFAFF 3586-12/02
PFAFF 3586-13/01

12.04

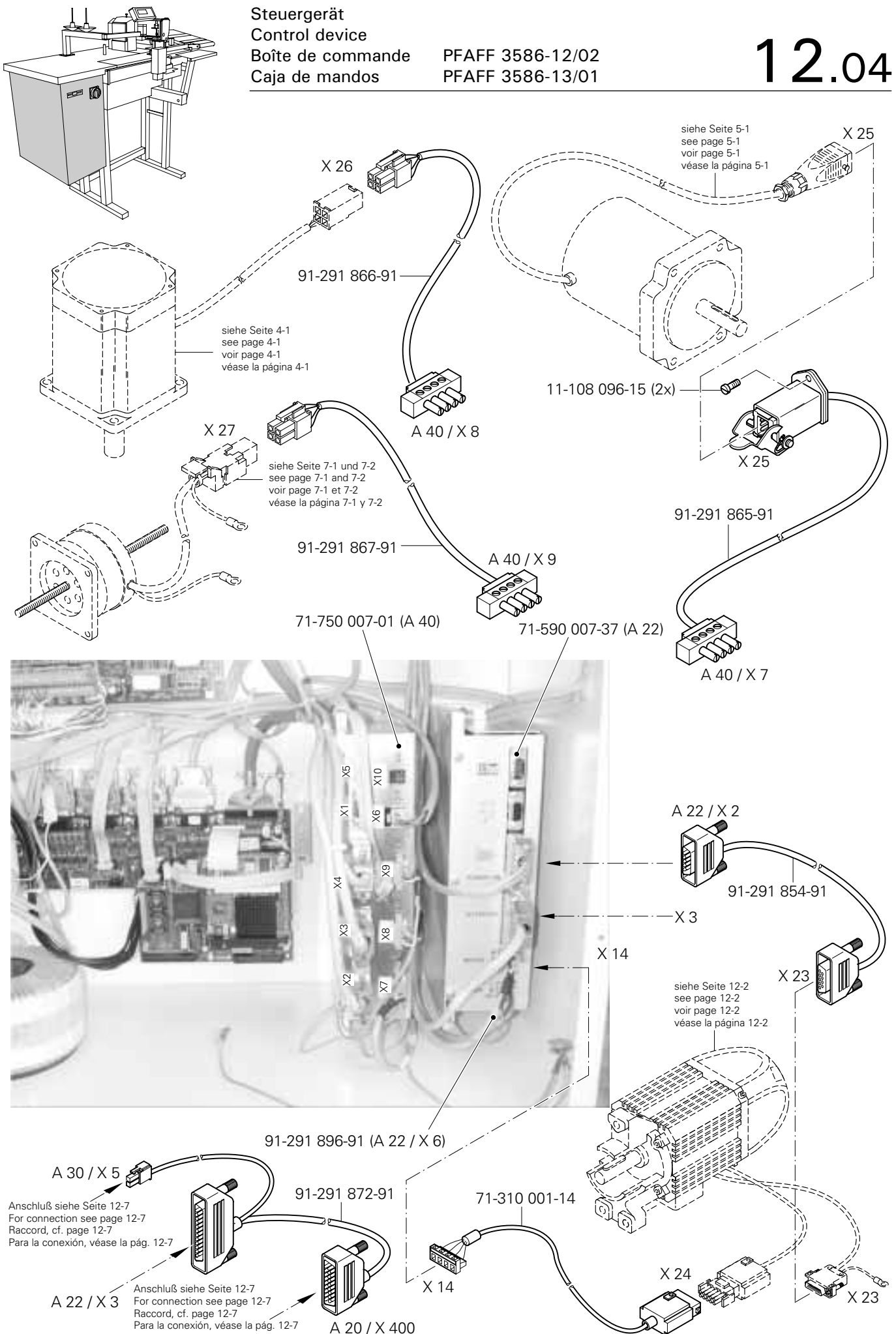

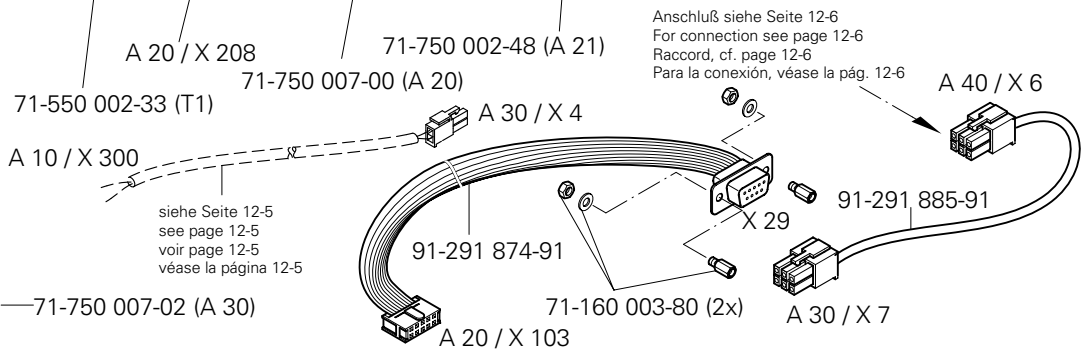
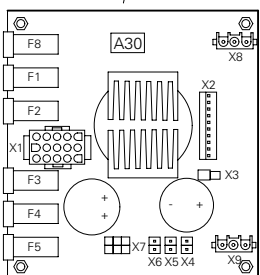
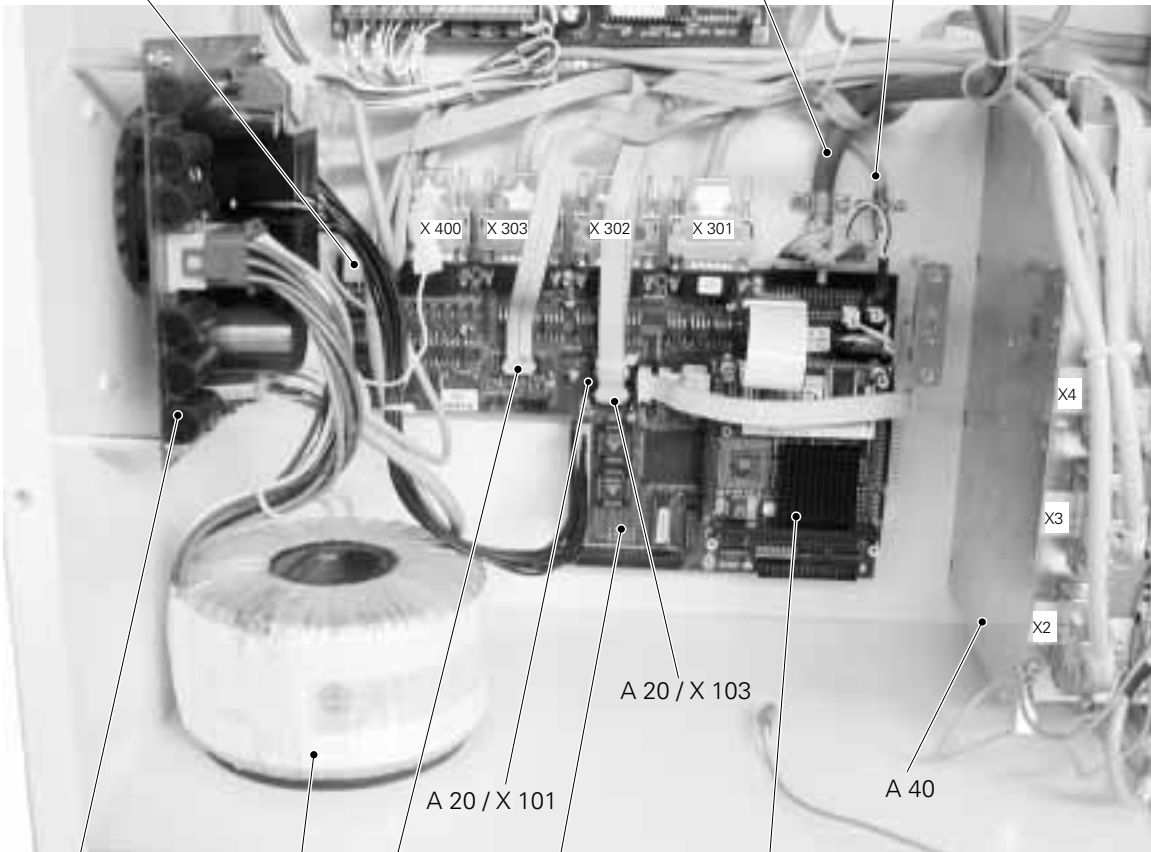
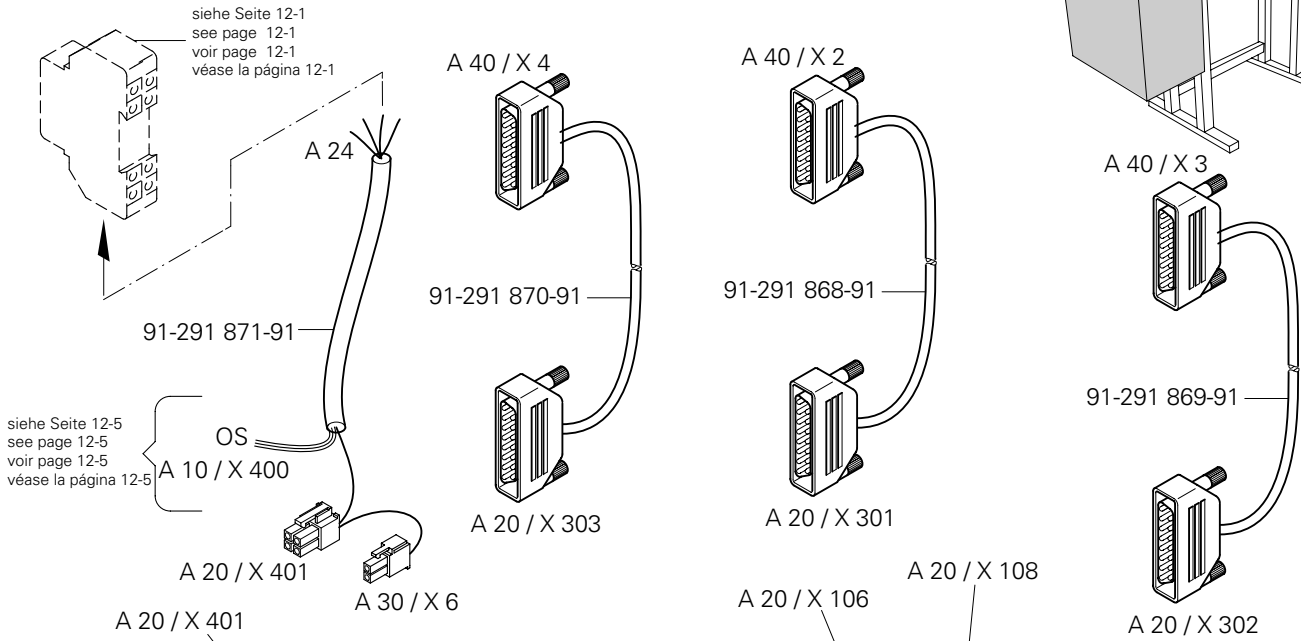
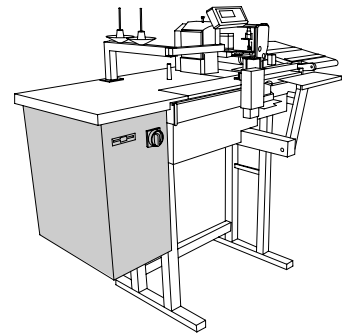

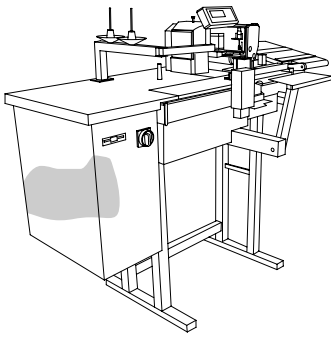

Steuergerät
Control device
Boîte de commande
Caja de mandos

PFAFF 3586-12/02
PFAFF 3586-13/01

12.04

91-292 185-90

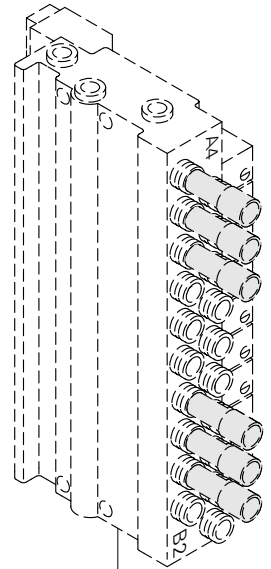
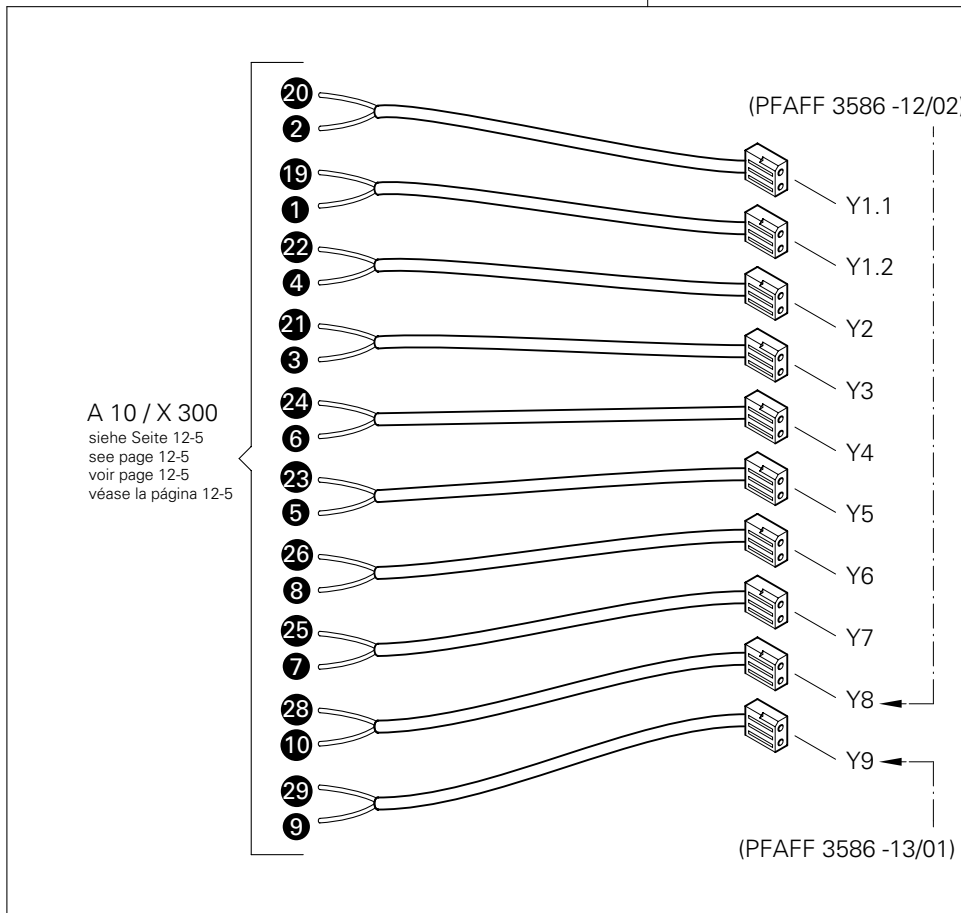

siehe Seite 11-1
see page 11-1
voir page 11-1
véase la página 11-1

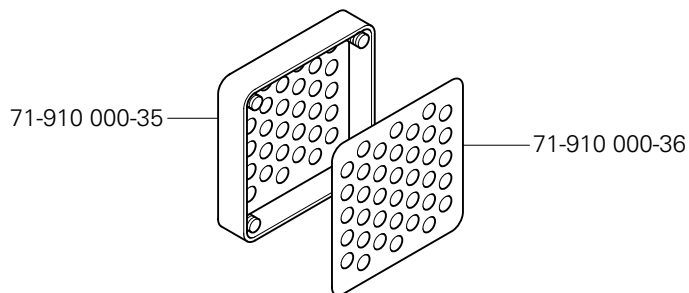

12.05

Tastschalter
Push-button
Interrupteur à bouton-poussoir
Interruptor pulsador

PFAFF 3586-13/01

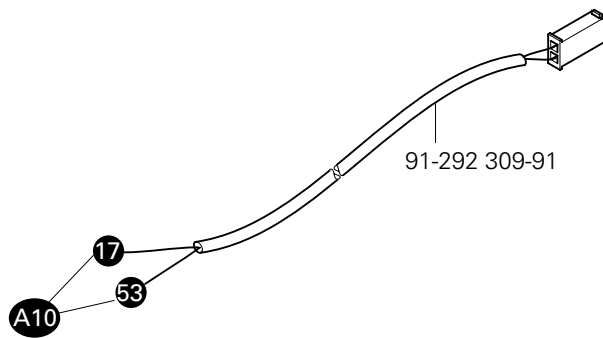
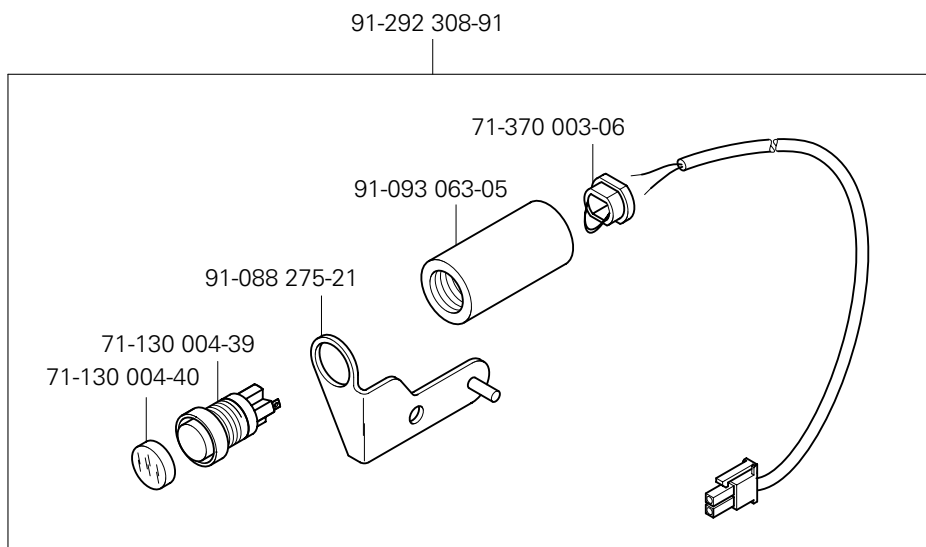
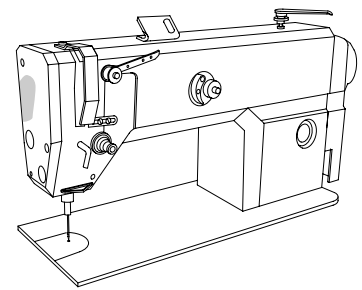

Anschluß siehe Seite 12-5
For connection see page 12-5
Raccord, cf. page 12-5
Para la conexión, véase la pág. 12-5

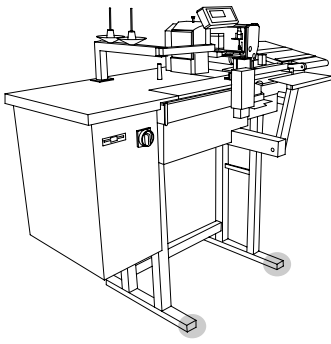

Gestell mit Anbauteilen
Stand with assembly parts
Bâti avec éléments de montage PFAFF 3586-12/02
Bancada con piezas de montaje PFAFF 3586-13/01

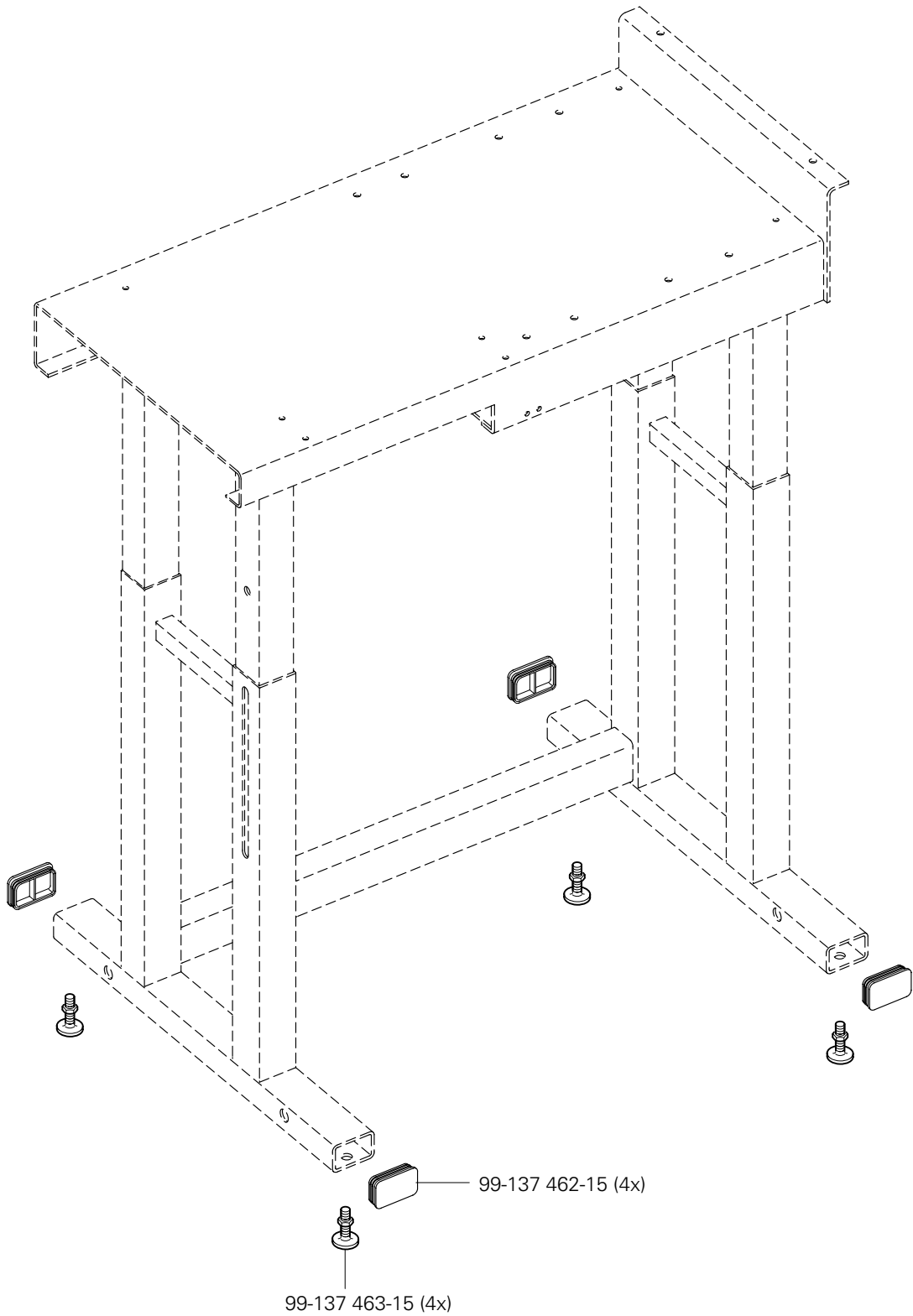

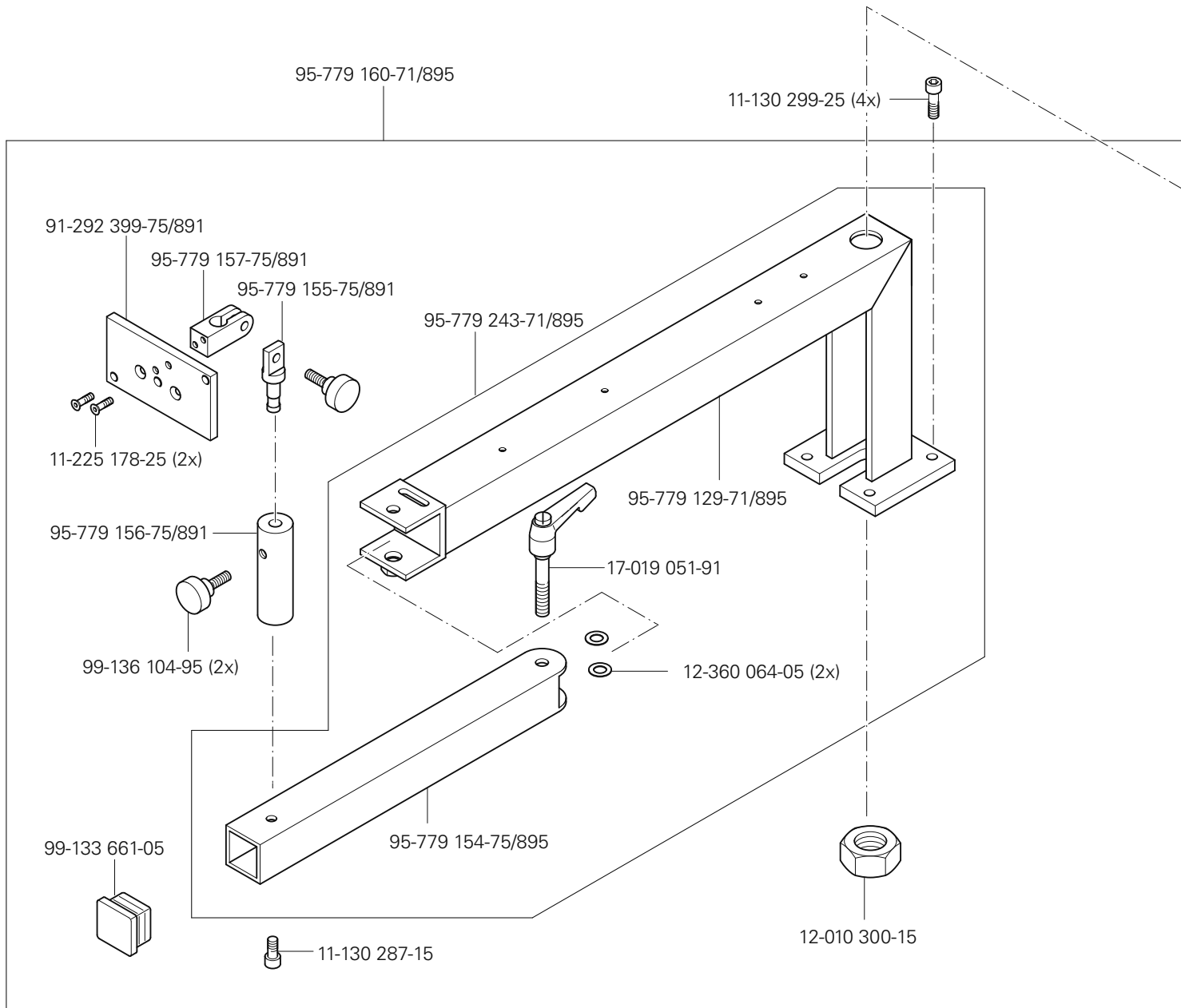
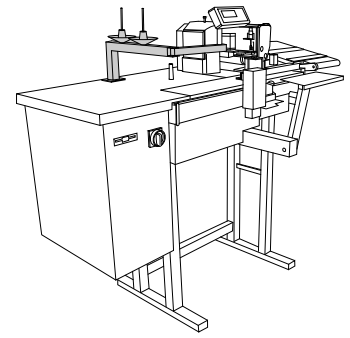

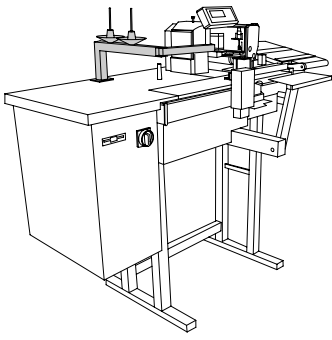

Garnrollenständer
 Reel stands
 Porte-bobines
 Portacarretes

PFAFF 3586-12/02
 PFAFF 3586-13/01

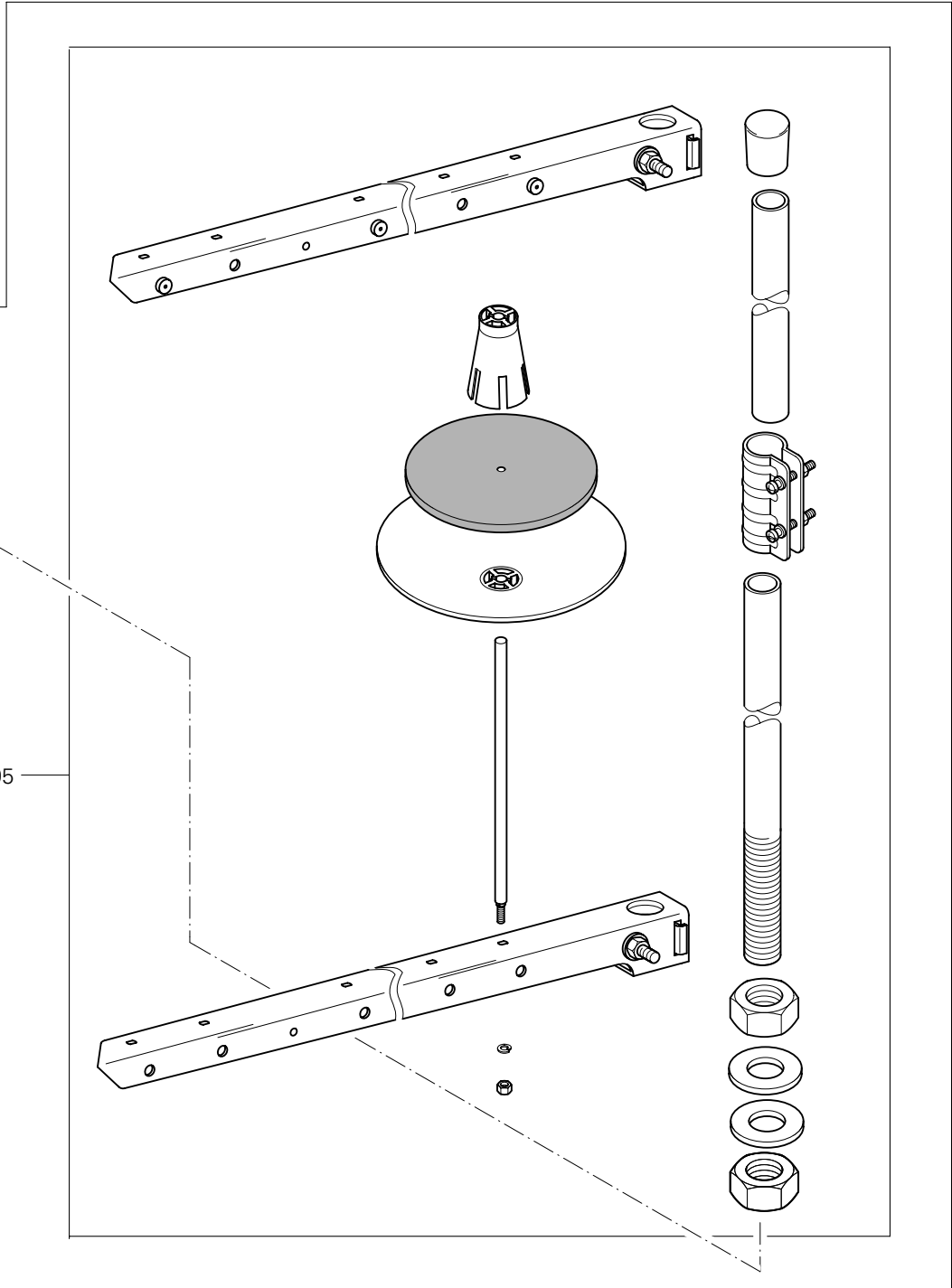

91-229 070-70/895

15

Einstellehren
Adjustment gauges
Calibres
Calibres de ajuste

PFAFF 3586-12/02
PFAFF 3586-13/01

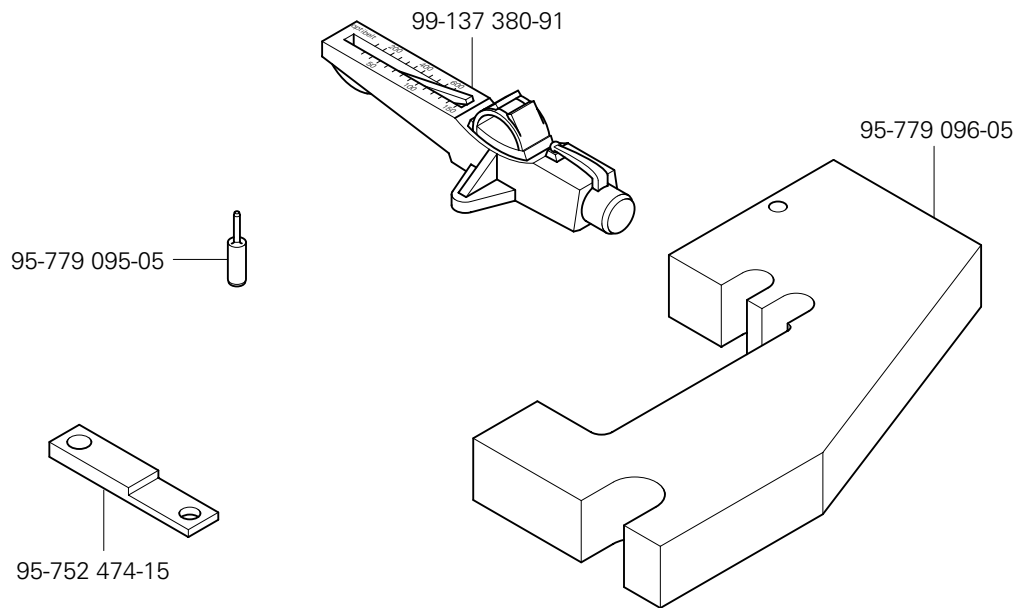

16

Teile zur Tischplatte
Parts for table top
Pièces du plateau
Piezas para el tablero

PFAFF 3586-12/02
PFAFF 3586-13/01

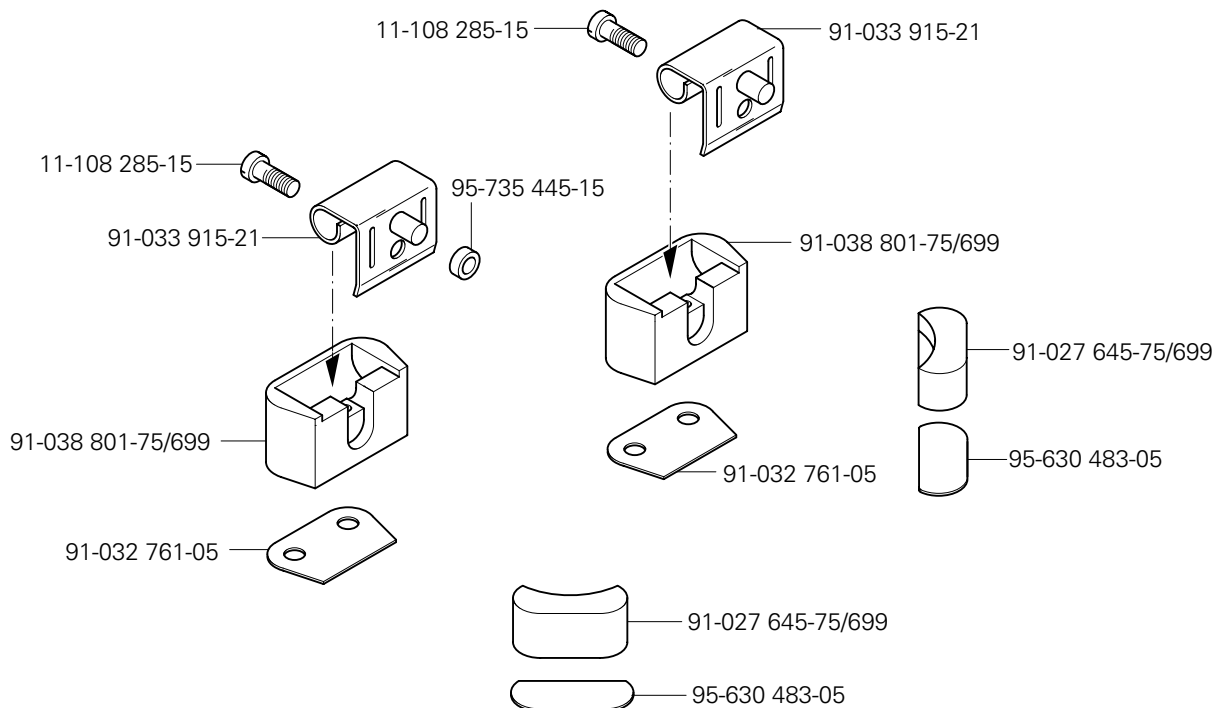

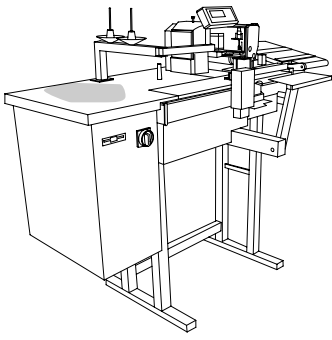

Ablagebox
Collection box
Boîte à prince
Caja de apilado

PFAFF 3586-12/02
PFAFF 3586-13/01

17

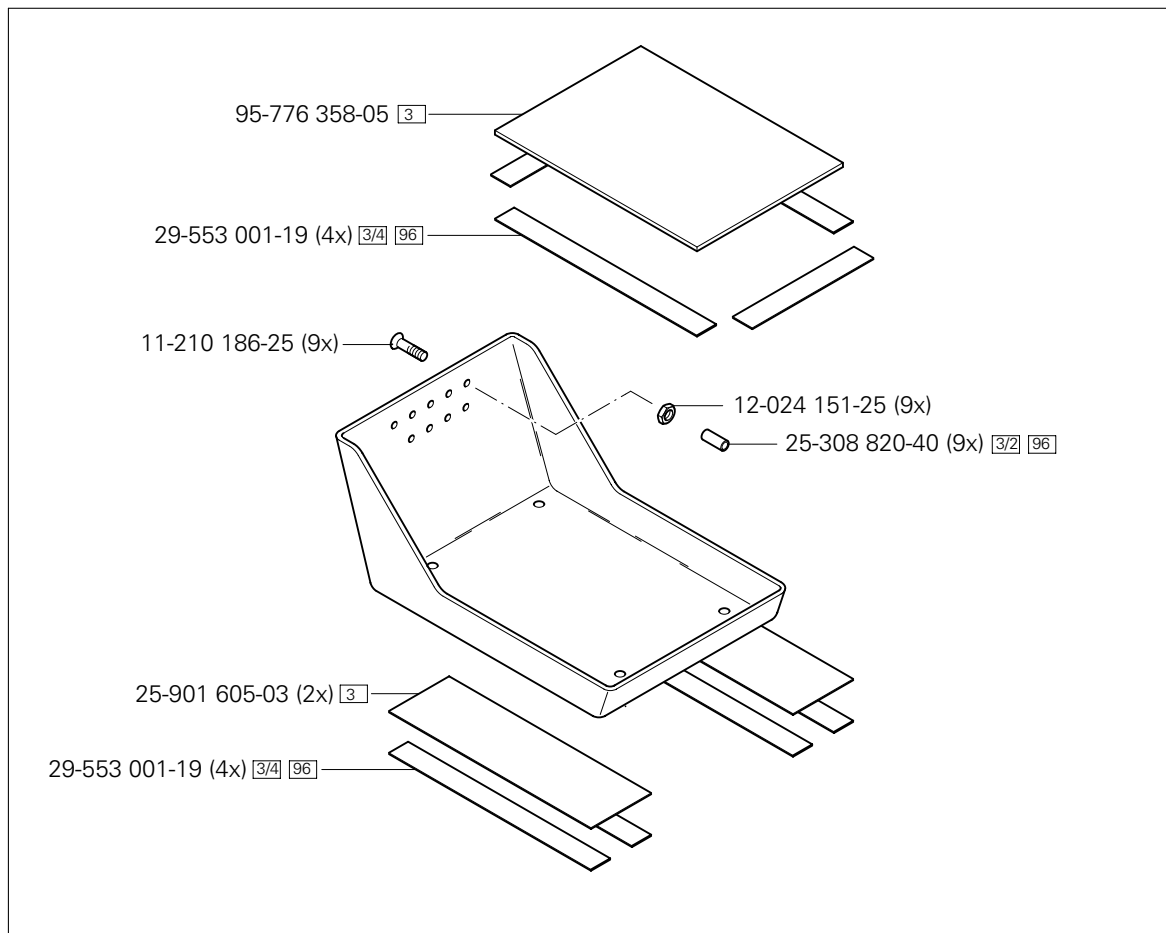

95-779 323-91
(Option bei PFAFF 3586 -12/02)
(Option for PFAFF 3586 -12/02)
(Option pour PFAFF 3586 -12/02)
(Optione para PFAFF 3586 -12/02)

Öl Oil Huile Aceite	Mittelpunkts-Viskosität bei: Mean viscosity at: Viscosité moyenne à: Viscosidad media a:		Dichte bei: Density of: Densité à: Densidad a:		Bestellnummer für Behälter mit: Part number for can with: Numéro de commande pour récipients avec: Número de pedido para recipientes con:		
	°C	mm ² /s	°C	g/cm ³ (g/ml)	1 Liter 1 Litre 1 Litro		
28-011 201-44	40	22,0	15	0,865	91-129 917-91		

Fett Grease Graisse Grasa	Penetration Penetration Pénétration Penetración	Tropfpunkt Drip-point Point de suintement Punto de goteo	Bestellnummer für Behälter mit: Part number for can with: Numéro de commande pour récipients avec: Número de pedido para recipientes con:		
			mm/10	°C	0,25 kg
28-011 202-05					28-011 202-05
28-011 202-10		185			28-011 202-10
28-011 202-43	375 - 405	150		28-011 202-43	
28-011 202-47	220 - 250	185			28-011 202-47

Reinigungsmittel Cleansing agent Agents de nettoyage Limpiadores	Bestellnummer für Behälter mit: Part number for can with: Numéro de commande pour récipients avec: Número de pedido para recipientes con:		
	240 ml		
Isoprophyl-Alkohol	95-665 735-91		

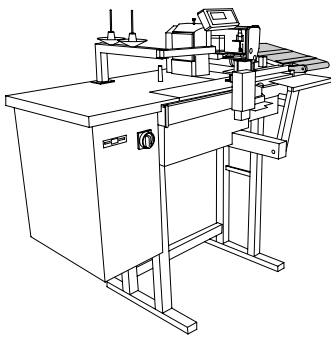

Bausatz Bündelklammer
Bundle clamp kit
Jeu de Pièces pour pince-paquet
Juego de piezas para pinzas para

PFAFF 3586-12/02

19.01

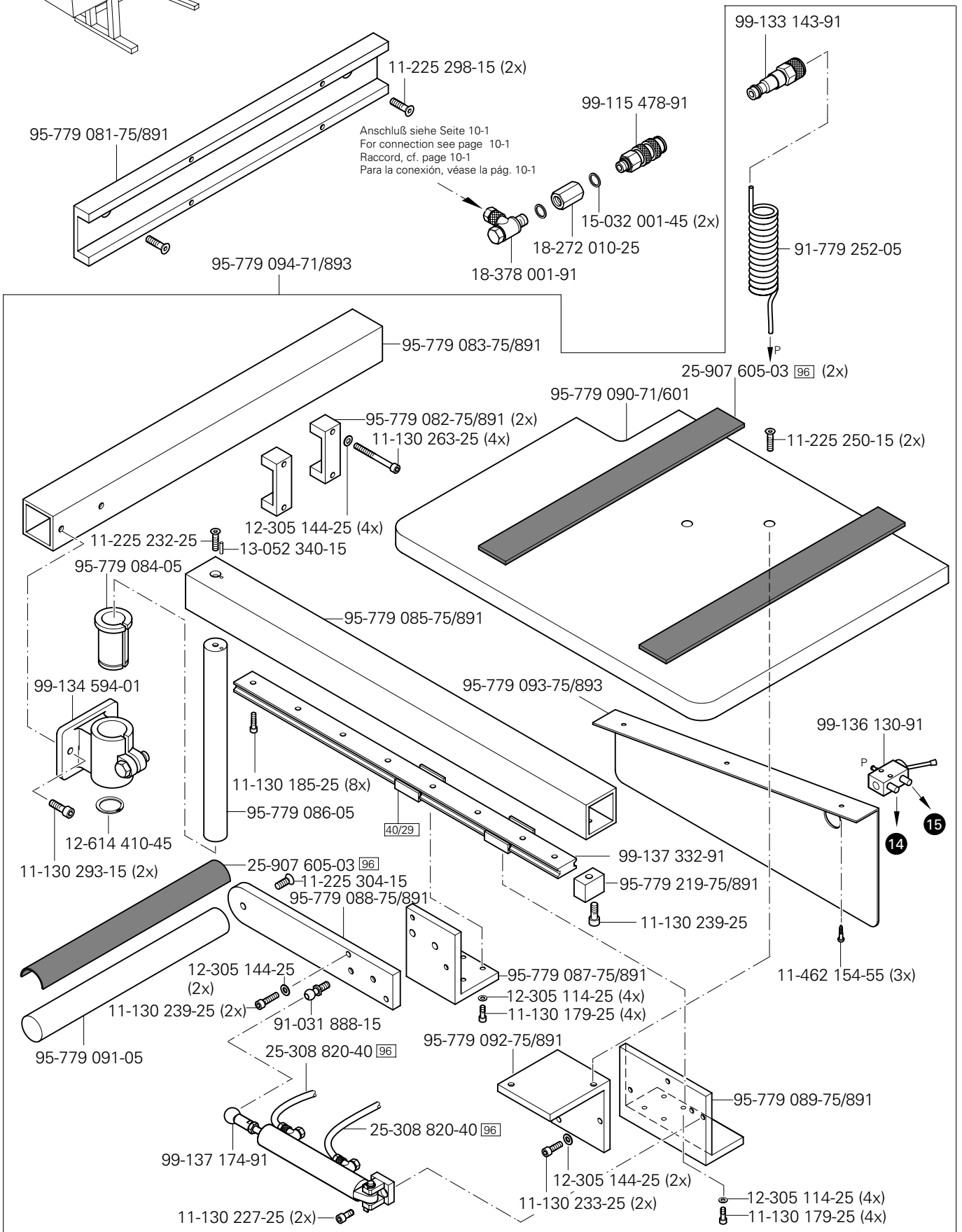

☐ siehe Kapitel 2 Erläuterung der Schlüsselzeichen
 see chapter 2 Explanation of key markings
 voir le chap. 2 Explication des symboles
 véase el Cap. 2 Explicaciones de los signos clave

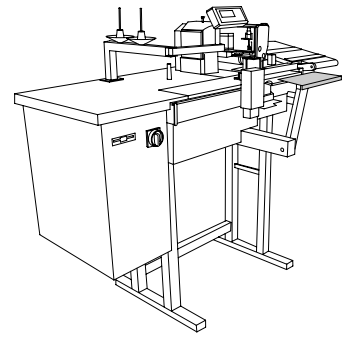

95-779 303-90

11-180 094-15 (2x)

95-779 301-05

95-779 304-05

Anschluß siehe Seite 11-1
For connection see page 11-1
Raccord, cf. page 11-1
Para la conexión, véase la pág. 11-1

12

25-308 820-40 96

99-134 851-91

15-032 001-45

11-130 254-15 (2x)

95-779 302-05

11-039 222-15

99-136 171-91

siehe Seite 9-1
see page 9-1
voir page 9-1
véase la página 9-1

siehe Seite 9-1
see page 9-1
voir page 9-1
véase la página 9-1

No.	Seite Page Pages Página	No.	Seite Page Pages Página	No.	Seite Page Pages Página	No.	Seite Page Pages Página
09-009 070-26	11 - 2	11-130 239-25	5 - 1, 7 - 1, 7 - 2, 9 - 1, 19 - 1	11-225 232-25	19 - 1	12-024 151-25	4 - 1, 8 - 1, 17 - 1
11-039 222-15	19 - 2	11-130 251-15	5 - 1	11-225 250-15	19 - 1	12-024 191-15	11 - 2
11-039 291-15	11 - 2	11-130 254-15	19 - 2	11-225 298-15	5 - 1, 19 - 1	12-024 191-25	3 - 5, 5 - 1, 5 - 2, 7 - 1, 7 - 2, 9 - 1
11-108 084-15	3 - 6	11-130 257-25	3 - 1, 5 - 2	11-225 304-15	19 - 1	12-024 211-25	5 - 1, 9 - 1
11-108 087-15	3 - 6, 5 - 2	11-130 263-15	5 - 2	11-250 084-15	3 - 5	12-110 150-15	4 - 1
11-108 096-15	12 - 4, 12 - 6	11-130 263-25	19 - 1	11-250 196-25	4 - 1	12-177 076-05	6 - 1, 7 - 1, 7 - 2
11-108 099-25	12 - 4	11-130 287-25	14 - 1	11-330 085-15	3 - 3	12-177 106-05	7 - 1, 7 - 2
11-108 177-15	3 - 8	11-130 293-15	4 - 1, 5 - 2, 9 - 1	11-330 091-15	7 - 1, 7 - 2	12-305 084-15	4 - 1
11-108 177-25	12 - 4	11-130 293-25	19 - 1	11-330 094-15	7 - 1, 7 - 2	12-305 114-15	3 - 3
11-108 222-15	3 - 6	11-130 299-25	5 - 1, 7 - 1, 7 - 2, 14 - 1	11-330 166-15	3 - 2	12-305 114-25	7 - 1, 7 - 2, 19 - 1
11-108 222-25	3 - 1	11-130 305-25	5 - 2	11-330 175-15	3 - 5	12-305 144-25	4 - 1, 5 - 1, 9 - 1, 19 - 1
11-108 285-55	15 - 1	11-130 311-15	5 - 2	11-330 217-15	4 - 1	12-305 174-15	5 - 2, 7 - 1, 7 - 2, 9 - 1
11-130 092-15	7 - 1, 7 - 2	11-130 365-15	12 - 2	11-330 220-15	3 - 2, 3 - 3, 4 - 1, 5 - 1	12-305 224-15	5 - 1, 9 - 1
11-130 095-15	4 - 1	11-132 172-15	12 - 1	11-330 232-15	4 - 1	12-335 131-15	3 - 7, 8 - 1
11-130 097-15	5 - 2	11-173 168-25	3 - 2	11-330 277-15	3 - 6, 3 - 7	12-335 171-15	5 - 1
11-130 101-15	4 - 1	11-173 222-25	12 - 4	11-330 280-15	3 - 4	12-349 122-05	4 - 1
11-130 108-15	4 - 1, 5 - 1, 7 - 1, 7 - 2, 9 - 1	11-174 089-15	12 - 1	11-330 960-15	12 - 2	12-349 901-05	3 - 6
11-130 110-15	3 - 7	11-178 233-25	8 - 1, 9 - 1	11-330 952-15	3 - 5, 3 - 6, 3 - 8	12-360 061-05	3 - 8
11-130 110-25	8 - 1	11-180 094-15	19 - 2	11-330 964-15	3 - 4, 3 - 8	12-360 064-05	3 - 3, 14 - 1
11-130 170-25	3 - 1	11-180 175-25	5 - 2, 8 - 1	11-330 968-15	3 - 8	12-499 120-45	4 - 1
11-130 173-25	4 - 1	11-180 223-15	9 - 1	11-335 085-15	3 - 6	12-499 150-45	7 - 1, 7 - 2
11-130 176-15	3 - 3	11-180 223-25	6 - 1	11-335 217-15	3 - 2	12-499 170-45	5 - 1, 9 - 1
11-130 176-25	4 - 1, 7 - 1, 7 - 2	11-180 283-25	3 - 1	11-335 280-15	3 - 4, 3 - 8	12-499 190-45	5 - 1
11-130 179-25	4 - 1, 5 - 2, 7 - 1, 7 - 2, 12 - 3, 19 - 1	11-186 226-25	4 - 1, 7 - 1, 7 - 2	11-341 166-15	11 - 2	12-500 190-45	9 - 1, 11 - 2
11-130 185-25	19 - 1	11-210 078-25	9 - 1	11-341 169-15	4 - 1	12-501 150-45	4 - 1, 5 - 2
11-130 191-25	4 - 1	11-210 168-25	3 - 5	11-341 277-15	3 - 3	12-501 170-45	4 - 1
11-130 206-15	7 - 1, 7 - 2	11-210 174-25	11 - 2	11-462 154-55	8 - 1, 11 - 2, 19 - 1	12-510 111-25	7 - 1, 7 - 2
11-130 224-25	3 - 1, 3 - 4, 5 - 1, 12 - 1	11-210 186-25	17 - 1	11-560 190-15	4 - 1	12-518 150-45	3 - 7
11-130 227-15	4 - 1	11-210 265-15	3 - 4	11-724 150-55	5 - 1, 7 - 1, 7 - 2	12-610 120-45	3 - 7
11-130 227-25	5 - 1, 5 - 2, 19 - 1	11-225 175-15	7 - 1, 7 - 2	11-724 320-55	5 - 1	12-610 150-45	7 - 1
11-130 233-15	4 - 1, 9 - 1	11-225 178-25	5 - 2, 14 - 1	12-005 175-25	9 - 1	12-610 190-45	3 - 7
11-130 233-25	19 - 1	11-225 220-15	3 - 1	12-010 300-15	14 - 1	12-610 210-45	3 - 3, 3 - 8
		11-225 223-15	3 - 3, 6 - 1, 9 - 1, 19 - 1	12-024 121-15	3 - 7, 5 - 2, 8 - 1	12-610 230-45	3 - 6

No.	Seite Page Pages Página	No.	Seite Page Pages Página	No.	Seite Page Pages Página	No.	Seite Page Pages Página
12-610 250-45	3 - 8	18-378 008-91	3 - 7	71-370 003-06	12 - 9	91-069 585-25	3 - 5
12-618 190-45	3 - 5	18-385 002-91	10 - 1	71-370 003-95	12 - 4	91-088 275-21	12 - 9
12-614 410-45	19 - 1	18-385 004-91	10 - 1	71-370 003-96	12 - 4	93-093 063-05	12 - 9
12-640 130-55	3 - 5	25-143 855-14	5 - 2, 7 - 1, 7 - 2	71-370 003-97	7 - 1, 7 - 2	91-100 400-15	3 - 4
12-660 390-45	3 - 6	25-161 801-49	3 - 3, 3 - 4	71-480 000-12	12 - 4	91-118 570-92	3 - 4
12-710 190-02	9 - 1	25-161 801-52	3 - 3, 3 - 6	71-523 555-76	12 - 2	91-118 683-05	3 - 5
13-033 190-05	3 - 6	25-161 802-35	11 - 2	71-550 002-33	12 - 7	91-161 334-25	3 - 2
13-033 322-05	7 - 1, 7 - 2	25-161 802-58	11 - 2	71-590 007-37	12 - 6	91-162 578-71/698	3 - 1
13-052 085-55	3 - 4	25-308 820-30	3 - 2, 3 - 7, 4 - 1	71-630 001-38	5 - 1	91-162 984-05	3 - 2
13-052 154-15	7 - 1, 7 - 2	25-308 820-40	3 - 2, 7 - 1, 10 - 1, 11 - 1, 11 - 2, 17 - 1, 19 - 1, 19 - 2	71-630 002-83	5 - 1, 7 - 1, 7 - 2, 9 - 1	91-165 685-05	3 - 6
13-052 340-15	19 - 1			71-750 002-48	12 - 7	91-166 114-05	7 - 1, 7 - 2
13-063 193-05	3 - 6	25-308 820-60	10 - 1	71-750 007-00	12 - 7	91-167 590-15	3 - 1
13-250 097-25	3 - 3	25-901 605-03	17 - 1	71-750 007-01	12 - 6	91-168 480-15	3 - 4
13-540 046-05	5 - 1	25-907 605-03	19 - 1	71-750 007-02	12 - 7	91-169 556-05	3 - 7
14-012 916-01	3 - 8	26-536 301-09	3 - 3, 3 - 6	71-750 007-03	12 - 3	91-171 049-05	3 - 5
14-016 080-01	3 - 6	28-011 201-05	18 - 1	71-770 000-60	12 - 4	91-171 785-05	3 - 6
14-016 101-91	3 - 8	28-011 202-05	18 - 1	71-910 000-35	12 - 8	91-174 396-05	3 - 2
14-016 151-91	3 - 4	28-011 202-10	18 - 1	71-910 000-36	12 - 8	91-174 438-25	3 - 2
14-016 171-91	3 - 8	28-011 202-43	18 - 1	91-002 065-05	3 - 2	91-174 439-25	3 - 2
14-018 624-91	3 - 4	29-553 001-19	17 - 1	91-006 814-05	3 - 2	91-174 440-25	3 - 2
14-210 040-01	4 - 1	28-911 200-42	5 - 2	91-009 341-05	4 - 1	91-174 441-05	3 - 2
14-602 901-01	3 - 5	49-150 100-02	7 - 1, 7 - 2	91-027 645-75/699	15 - 1	91-174 879-05	3 - 5
14-731 369-05	4 - 1	70-151 500-26	12 - 4	91-027 975-91	18 - 1	91-229 070-70/895	14 - 2
15-032 001-45	11 - 2, 19 - 1, 19 - 2	71-110 003-07	12 - 4	91-027 976-91	18 - 1	91-262 061-05	3 - 8
15-032 001-55	7 - 1	71-120 006-32	8 - 1	91-027 977-91	18 - 1	91-262 062-92	3 - 8
15-032 002-45	10 - 1	71-130 004-39	12 - 9	91-031 888-15	19 - 1	91-262 069-15	3 - 7
16-041 065-11	9 - 1	71-130 004-40	12 - 9	91-032 761-05	15 - 1	91-262 136-15	3 - 7
16-409 927-05	5 - 2	71-130 005-52	4 - 1, 5 - 1, 7 - 1, 7 - 2, 9 - 1	91-033 915-21	15 - 1	91-262 138-15	3 - 7
16-409 983-05	3 - 8	71-160 003-80	12 - 7	91-038 801-75/699	15 - 1	91-262 146-91	3 - 7
17-019 051-91	14 - 1	71-160 008-83	12 - 5	91-056 197-91	3 - 5	91-262 149-05	3 - 7
18-050 001-91	10 - 1	71-310 001-14	12 - 6	91-056 578-91	3 - 5	91-262 161-72/698	3 - 4
18-272 010-25	11 - 2, 19 - 1	71-370 001-59	12 - 4	91-056 760-05	3 - 5	91-262 162-75/698	3 - 1
18-378 001-91	11 - 2, 19 - 1	71-370 001-75	12 - 4	91-069 105-25	3 - 2	91-262 185-15	3 - 6

No.	Seite Page Pages Página	No.	Seite Page Pages Página	No.	Seite Page Pages Página	No.	Seite Page Pages Página
91-262 187-15	3 - 6	91-263 201-01	3 - 4	91-291 873-91	12 - 3	95-752 446-15	4 - 1
91-262 188-15	3 - 6	91-264 154-25	3 - 6	91-291 874-91	12 - 7	95-752 472-05	3 - 3
91-262 189-91	3 - 6	91-264 233-15	3 - 1	91-291 884-91	12 - 5	95-752 473-91	3 - 3
91-262 195-92	3 - 4	91-264 240-05	3 - 6	91-291 885-91	12 - 7	95-752 474-15	15 - 1
91-262 196-05	3 - 4	91-264 338-15	3 - 6	91-291 886-91	12 - 4	95-753 014-75/893	11 - 2
91-262 208-05	3 - 6	91-264 357-05	3 - 5	91-291 887-90	12 - 4	95-774 464-05	3 - 5
91-262 209-91	3 - 6	91-264 358-05	3 - 5	91-291 896-91	12 - 6	95-774 466-91	3 - 5
91-262 214-05	3 - 6	91-264 364-15	12 - 2	91-291 907-93/001	12 - 1	95-774 678-05	3 - 6
91-262 225-91	3 - 6	91-264 365-91	12 - 2	91-291 910-91	6 - 1	95-774 679-91	3 - 6
91-262 235-15	3 - 6	91-265 065-05	3 - 6	91-292 183-91	7 - 1, 7 - 2	95-774 681-91	3 - 6
91-262 250-91	3 - 6	91-266 397-01	3 - 5	91-292 185-90	12 - 8	95-776 358-05	17 - 1
91-262 304-45	3 - 3	91-268 076-15	3 - 6	91-292 308-91	12 - 9	95-778 182-91	12 - 1
91-262 320-91	3 - 3	91-269 266-05	4 - 1, 7 - 1	91-292 309-91	12 - 9	95-779 033-71/895	11 - 1, 11 - 2
91-262 329-75/895	3 - 1	91-291 051-91	5 - 1	91-292 340-91	12 - 3	95-779 072-71/893	8 - 1
91-262 354-05	3 - 3	91-291 362-93/001	12 - 5	91-292 369-90	12 - 4	95-779 073-75/893	8 - 1
91-262 360-05	3 - 6	91-291 810-91	12 - 4	91-292 370-93/001	12 - 4	95-779 076-71/895	8 - 1
91-262 376-91	3 - 6	91-291 811-91	12 - 4	91-292 371-93/001	12 - 4	95-779 079-05	5 - 1
91-262 377-91	3 - 6	91-291 853-91	12 - 5	91-292 372-90	12 - 4	95-779 081-75/891	19 - 1
91-262 437-05	3 - 6	91-291 854-91	12 - 6	91-700 996-15	3 - 5	95-779 082-75/891	19 - 1
91-262 566-05	3 - 8	91-291 855-91	12 - 5	95-215 000-04/885	7 - 1	95-779 083-75/891	19 - 1
91-262 566-92	3 - 8	91-291 856-91	4 - 1	95-215 000-04/886	3 - 2	95-779 084-05	19 - 1
91-262 576-05	12 - 2	91-291 858-91	4 - 1	95-215 000-04/911	9 - 1	95-779 085-75/891	19 - 1
91-262 688-91	3 - 4	91-291 859-91	4 - 1	95-630 483-05	15 - 1	95-779 086-05	19 - 1
91-262 787-91	3 - 3	91-291 860-91	12 - 5	95-665 735-91	18 - 1	95-779 087-75/891	19 - 1
91-262 788-91	3 - 3	91-291 861-91	12 - 5	95-669 358-05	3 - 6	95-779 088-75/891	19 - 1
91-262 819-05	3 - 3	91-291 865-91	12 - 4, 12 - 6	95-735 445-15	15 - 1	95-779 089-75/891	19 - 1
91-262 821-91	3 - 3	91-291 866-91	12 - 6	95-735 684-15	4 - 1	95-779 090-71/601	19 - 1
91-262 842-92	3 - 6	91-291 867-91	12 - 6	95-744 686-01	3 - 8	95-779 091-05	19 - 1
91-262 843-01	3 - 8	91-291 868-91	12 - 7	95-752 138-15	4 - 1	95-779 092-75/891	19 - 1
91-262 844-92	3 - 8	91-291 869-91	12 - 7	95-752 240-05	4 - 1	95-779 093-75/893	19 - 1
91-262 845-91	3 - 8	91-291 870-91	12 - 7	95-752 434-03/001	3 - 6	95-779 094-71/893	19 - 1
91-262 846-05	3 - 8	91-291 871-91	12 - 7	95-752 442-75/891	4 - 1	95-779 095-05	15 - 1
91-262 959-71/699	3 - 1	91-291 872-91	12 - 6	95-752 445-75/895	4 - 1	95-779 096-05	15 - 1

No.	Seite Page Pages Página	No.	Seite Page Pages Página	No.	Seite Page Pages Página	No.	Seite Page Pages Página
95-779 097-75/891 7 - 1, 7 - 2		95-779 197-71/891 9 - 1		95-779 301-05	19 - 2	99-133 143-91	19 - 1
95-779 098-91	7 - 1	95-779 201-75/895 9 - 1		95-779 302-05	19 - 2	99-133 154-01	5 - 2
95-779 126-71/601 6 - 1		95-779 205-05	9 - 1	95-779 303-90	19 - 2	99-133 661-05	14 - 1
95-779 129-71/895 14 - 1		95-779 206-75/895 9 - 1		95-779 304-05	19 - 2	99-133 753-91	11 - 2
95-779 137-75/891 4 - 1		95-779 208-05	6 - 1	95-779 306-01	9 - 1	99-134 014-05	10 - 1
95-779 138-75/891 4 - 1		95-779 209-05	5 - 2	95-779 308-01	9 - 1	99-134 299-91	3 - 7
95-779 143-05	5 - 2	95-779 210-05	5 - 2	95-779 310-05	9 - 1	99-134 416-91	11 - 2
95-779 144-05	5 - 2	95-779 213-01	5 - 2	95-779 311-75/895 9 - 1		99-134 594-01	19 - 1
95-779 145-05	5 - 1	95-779 214-91	5 - 2	95-779 321-75/891 7 - 1, 7 - 2		99-134 794-05	5 - 2
95-779 146-05	5 - 2	95-779 216-71/895 5 - 2		95-779 323-91	17 - 1	99-134 851-91	19 - 2
95-779 147-05	5 - 1	95-779 217-75/895 5 - 2		95-779 324-71/601 6 - 1		99-134 960-91	7 - 1, 7 - 2
95-779 148-15	5 - 2	95-779 218-75/891 5 - 2		95-779 325-05	6 - 1	99-135 127-91	3 - 7
95-779 149-91	5 - 1	95-779 219-75/891 5 - 1, 19 - 1		95-779 326-71/895 9 - 1		99-135 496-95	11 - 2
95-779 154-75/895 14 - 1		95-779 243-71/895 14 - 1		95-779 327-71/891 9 - 1		99-135 617-95	7 - 1
95-779 155-75/891 14 - 1		95-779 252-05	19 - 1	95-779 329-05	9 - 1	99-135 835-05	11 - 1
95-779 156-75/891 14 - 1		95-779 259-75/891 4 - 1		95-779 330-01	9 - 1	99-136 071-95	3 - 2
95-779 157-75/891 14 - 1		95-779 260-75/891 4 - 1		95-779 331-71/895 5 - 2		99-136 104-95	14 - 1
95-779 158-75/891 14 - 1		95-779 261-75/891 4 - 1		95-779 332-91	5 - 2	99-136 130-91	19 - 1
95-779 160-71/895 14 - 1		95-779 262-25	4 - 1	95-779 335-05	5 - 2	99-136 171-91	19 - 2
95-779 167-05	3 - 1	95-779 265-75/891 7 - 1		95-779 336-71/891 7 - 2		99-136 391-91	9 - 1
95-779 174-91	3 - 2	95-779 268-71/891 4 - 1		95-779 337-75/891 7 - 2		99-136 476-25	11 - 1
95-779 175-05	3 - 7	95-779 269-15	4 - 1	95-779 339-71/891 7 - 2		99-136 546-91	10 - 1
95-779 176-15	3 - 7	95-779 270-91	5 - 2	95-779 341-71/891 11 - 2		99-136 585-95	8 - 1, 9 - 1
95-779 177-05	12 - 1	95-779 271-91	5 - 2	95-779 342-71/891 11 - 2		99-137 151-45	3 - 5
95-779 178-05	3 - 7	95-779 273-05	9 - 1	95-779 343-75/891 11 - 2		99-137 174-91	19 - 1
95-779 180-15	7 - 1	95-779 275-75/895 12 - 1		95-779 344-71/891 11 - 2		99-137 187-15	3 - 6
95-779 181-71/891 7 - 1, 7 - 2		95-779 276-71/895 9 - 1		95-779 347-71/891 11 - 2		99-137 188-15	3 - 6
95-779 188-71/891 7 - 1, 7 - 2		95-779 278-71/895 5 - 2		95-779 350-71/895 3 - 2		99-137 190-05	3 - 6
95-779 189-75/891 7 - 1, 7 - 2		95-779 280-05	7 - 1	96-720 045-05	9 - 1	99-137 191-05	3 - 6
95-779 190-75/891 7 - 1, 7 - 2		95-779 281-71/891 7 - 1		97-301 183-25/893 6 - 1		99-137 192-05	3 - 6
95-779 192-15	9 - 1	95-779 282-75/895 4 - 1		99-115 034-15	14 - 1	99-137 193-05	3 - 6
95-779 195-71/895 9 - 1		95-779 283-71/895 4 - 1		99-115 478-91	19 - 1	99-137 194-05	3 - 6
95-779 196-15	9 - 1	95-779 299-05	9 - 1	99-115 523-91	8 - 1	99-137 273-91	4 - 1

No.	Seite Page Pages Página	No.	Seite Page Pages Página	No.	Seite Page Pages Página	No.	Seite Page Pages Página
99-137 300-91	9 - 1						
99-137 301-91	5 - 1						
99-137 302-91	5 - 2						
99-137 303-95	5 - 2						
99-137 321-91	4 - 1						
99-137 328-91	7 - 1, 7 - 2						
99-137 332-91	19 - 1						
99-137 380-91	15 - 1						
99-137 405-15	3 - 6						
99-137 459-91	11 - 1						
99-137 462-15	13 - 1						
99-137 463-15	13 - 1						
99-137 491-05	4 - 1						
99-137 492-05	7 - 1, 7 - 2						
99-137 493-05	7 - 1, 11 - 2						



Europäische Union
Wachstum durch Innovation – EFRE



PFAFF Industriesysteme und Maschinen AG

Hans-Geiger-Str. 12 - IG Nord
D-67661 Kaiserslautern

Telefon: +49 - 631 200-0
Telefax: +49 - 631 17202
E-mail: info@pfaff-industrial.com

Hotlines:

Technischer Service / Technical service:
Service technique / Servicio técnico: +49 - 175 2243-101

Nähtechnik-Fachberatung / Application consultancy:
Conseiller de couture et technique / Asesor técnico: +49 - 175 2243-102

Ersatzteile-Hotline / Spare-parts hotline:
Hotline - Pièces détachées / Hotline Repuestos: +49 - 175 2243-103