

3519-3/12

Teileliste

Parts list

Liste de pièces

Lista de piezas

Diese Teileliste hat für Maschinen ab nachfolgender
Seriennummer Gültigkeit:

This parts list applies to machines from the following
serial numbers onwards:

Cette liste de pièces est valable pour les machines au
numéros de série à partir de:

Esta lista de piezas tiene validez para máquinas a partir del
número de serie siguiente:

2226105 →

Alle Informationen und Abbildungen waren zum Zeitpunkt der Druckgebung auf dem neusten Stand.

Technische Änderungen vorbehalten!

Der Nachdruck, die Vervielfältigung sowie die Übersetzung - auch auszugsweise - aus PFAFF-Teilelisten ist nur mit unserer vorherigen Zustimmung und mit der Quellenangabe gestattet.

At the time of printing, all information and illustrations contained in this document were up to date.

Subject to alteration!

The reprinting, copying or translation of PFAFF Parts lists whether in whole or in part, is only permitted with our previous permission and with written reference to the source.

Au moment de la remise à l'imprimeur, toutes les informations et figures se rapportant à cette machine correspondaient à l'état actuel des connaissances.

Sous réserve de modifications techniques!

Aucune reproduction, photocopie ou traduction - même par extraits - des listes de pièces PFAFF ne peut être effectuée, à condition d'en indiquer l'origine, sans notre autorisation expresse.

Todas las informaciones e ilustraciones de este manual estaban al día en el momento de entregarse para su impresión.

¡ Salvo modificaciones técnicas!

La reimpresión, reproducción y traducción - aunque sólo sea parcial - de las listas de piezas PFAFF sólo está permitida con nuestro permiso previo e indicando la fuente.

**G.M. PFAFF KAISERSLAUTERN
INDUSTRIEMASCHINEN AG**

Postfach 3020
D-67653 Kaiserslautern

Königstr. 154
D-67655 Kaiserslautern

Redaktion/Illustration
Verlag Technische Dokumentation
Postfach 1106
D-77901 Lahr

	Seite Page Page Página
0 Wichtiger Hinweis	0 - 1
Important note	
Avis important	
Observación importante	
1 Vorwort	1 - 1
Foreword	
Avant-propos	
Notas preliminares	
2 Erläuterungen der Schlüsselzeichen	2 - 1
Explanation of key markings	
Explication des symboles	
Explicaciones de los signos clave	
3 Nähmaschine	
Sewing machine	
Tête de machine	
Máquina de coser	
3.01 Gehäuseteile	3 - 1
Housing sections	
Parties du corps	
Piezas del cárter	
3.02 Kopfteile	3 - 2
Needle head parts	
Pièces de tête	
Piezas de la cabeza	
3.03 Armteile	3 - 7
Arm parts	
Pièces de bras	
Piezas del brazo	
3.04 Grundplattenteile	3 - 13
Bedplate parts	
Pièces du plateau fondamental	
Piezas del cárter	
4 Oberteilführung	4 - 1
Sewing head guide	
Guide de tête	
Guía de parte superior	

		Seite Page Page Página
5	Stoffübernahme Material take-over unit Pince-ouvrage Sujetatelas	5 - 1
6	Schneidvorrichtung Cutting device Dispositif de coupe Dispositivo de corte	6 - 1
7	Bausatz für Zuführtisch Kit for infeed plate Kit pour table de chargement Juego de montaje de la mesa de alimentación	7 - 1
8	Abstreifvorrichtung Wiping device Racleur de fil Deflector	8 - 1
9	Positioniereinrichtung Positioning device Dispositif positionneur Dispositivo posicionador	9 - 1
10	Laser Laser Laser Láser	10 - 1
11	X-Y-Antrieb X-Y drive Système de commande X-Y Grupo de accionamiento "X-Y"	11 - 1
12	Stapler Stacker Empileur Apilador	12 - 1
13	Verteiler für Saugereinrichtung Distributor for vacuum system Distributeur de dispositif d'aspiration Distribuidor para dispositivo de aspiración	12 - 1

	Seite Page Page Página
14 Pneumatische Ausrüstung	14 - 1
Pneumatic equipment	
Équipement pneumatique	
Equipo neumático	
15 Elektrische Ausrüstung	
Electrical equipment	
Équipement électrique	
Equipo eléctrico	
15.01 Bedienfeld	15 - 1
Control panel	
Panneau de commande	
Panel de mandos	
15.02 Verteiler	15 - 3
Distributor	
Distributeur	
Distribuidor	
15.03 Steuergerät	15 - 10
Control device	
Boîte de commande	
Caja de mandos	
15.04 Fußtaster mit Leitung	15 - 13
Foot control with cord	
Interrupteur au pied, avec câble	
Interruptor de pie, con cable	
16 Garnrollenständer	16 - 1
Reel stands	
Porte-bobines	
Portacarretes	
17 Einstellehren	17 - 1
Adjustment gauges	
Calibres	
Calibres de ajuste	
18 Schmiermittel-Übersicht	18 - 1
Overview of lubricants	
Tableau de lubrifiants	
Tabla de lubricantes	

	Seite Page Page Página
19 Optionen Options Options Opciones	
19.01 Zuführeinrichtung	19 - 1
Feed unit Dispositif d'alimentation Alimentador	
20 Index (Teilenummern / Seitenzahlen)	20 - 1
Index (part numbers / page numbers) Index (numéros de pièces, de pages) Index (números de pieza / números de página)	

Achtung!



Wir machen ausdrücklich darauf aufmerksam, daß Ersatz- und Zubehörteile, die nicht von uns geliefert werden, auch nicht von uns geprüft und freigegeben sind. Der Einbau und / oder die Verwendung solcher Produkte kann daher u. Umständen konstruktiv vorgegebene Eigenschaften Ihrer Maschine negativ verändern. Für Schäden, die durch die Verwendung von Nicht-Originalteilen entstehen, übernehmen wir keine Haftung!

Caution!



We warn you expressively that spare parts and accessories that are not supplied by us are not tested and released by us. Fitting or using these products may therefore have negative influences on features that depend on the machine design. We are not liable for any damage caused by the use of non-Pfaff parts!

Attention!



Nous attirons expressément votre attention sur le fait que les pièces de rechange et accessoires qui n'ont pas été livrés par nous n'ont pas non plus été contrôlés et agréés par nous. C'est pourquoi le montage et/ou l'utilisation de telles pièces peut éventuellement entraîner l'altération des caractéristiques de construction de votre machine. Par conséquent, nous n'assumons aucune responsabilité pour les dommages causés par l'emploi de pièces qui ne sont pas d'origine!

¡Atención!



Se hace observar que en el caso de piezas de recambio y accesorios que no hayan sido suministrados por nosotros, quiere decir que non han sido sometidas por nuestra parte a un control y que no se les ha dado el visto bueno. Por esta razón, el montaje y/o empleo de tales productos puede repercutir negativamente en las características previstas en su máquina. ¡Para los daños que eventualmente pudiesen presentarse al utilizar piezas no originales, no asumimos ninguna garantía!

- Die Seriennummer der Maschine, für die diese Teileliste Gültigkeit hat, ist auf der Titelseite aufgeführt.
 - Alle Teile sind so abgebildet, wie sie in der Maschine funktionsmäßig zusammengehören.
 - Gestrichelt dargestellte Teile zeigen angrenzende Teile aus anderen Funktionsgruppen.
 - Im oberen Teil der Bildseiten befindet sich eine Gesamtansicht der Maschine .
 - Der Einbauort der dargestellten Teile wird durch eine gerasterte Fläche gekennzeichnet.
 - Einrahmungen auf den Bildseiten zeigen, aus welchen Einzelteilen sich die Gruppenteile zusammensetzen.
 - Die auf den Bildseiten verwendeten Schlüsselzeichen (; 2 ; 3 usw.) sind im Kapitel "Erläuterungen der Schlüsselzeichen" aufgelistet.
-
- The serial number of the machine to which this parts list applies is indicated on the cover page.
 - All parts are illustrated in function groups with the parts which they function together with in the machine.
 - Parts illustrated with broken lines are parts from other function groups which border on the illustrated function group.
 - The above section of the page of illustrations contains a total view of the machine. The place for the installation of the parts pictured here is marked by the grid.
 - The framed-in sections on the illustration pages show the individual parts comprising a group.
 - The key markings used on the illustrated pages (; 2 ; 3 etc.) are listed in the chapter "Explanation of key markings".
-
- Le numéro de série de la machine pour laquelle cette liste de pièces est valable est indiqué sur la première page.
 - Toutes les pièces sont représentées en fonction de leur groupement fonctionnel dans la machine.
 - Les pièces hâchurées indiquent les pièces limitrophes de groupes de fonctions différents.
 - La partie supérieure des pages de figures comprend une présentation globale de la machine. L'emplacement des pièces représentées est signalé par quadrillages.
 - Les parties encadrées sur les pages à illustrations représentent les pièces individuelles formant groupe.
 - Vous trouverez au chapitre "Explication des symboles" une liste des symboles utilisés sur les pages de figures (; 2 ; 3 etc.)
-
- El número de serie de la máquina para la cual tiene validez esta lista de piezas va indicado en la página de título.
 - Todas las piezas están ilustradas tal como aparecen en la máquina para su funcionamiento.
 - Las piezas representadas con rayitas muestran piezas colindantes de otros grupos de funciones.
 - En la parte superior de las páginas ilustradas se puede ver una vista en conjunto de la máquina.
 - El lugar de montaje de la pieza representada va caracterizada mediante una superficie reticulada.
 - Los recuadros en las páginas ilustradas indican las piezas individuales de que se componen los grupos.
 - Los signos clave (; 2 ; 3 etc.) empleados en las páginas con ilustraciones van listados en el capítulo "Explicaciones de los signos clave".

- 2** **Markierung (Punkte, Striche oder Zahl) bei Bestellung angeben.**
Marking (dots, strokes or numbers) to be stated on order.
Préciser les repères (points, traits ou chiffres) à la commande.
Señales (puntos, rayas o cifras), indíquese en los pedidos.
- 3** **Geklebt**
Part cemented
Pièce collée
Pieza pegada
- 3/3** **Selbstklebende Folie.**
Self-adhesive foil.
Feuille auto-adhésive.
Hoja autoadesiva.
- 6** **Nadeldicke und Spitzenform bei Bestellung angeben.**
Needle size and style of point to be stated on order.
Préciser la grosseur de l'aiguille et la forme de la pointe à la commande.
Grosor de aguja y forma de la punta, indíquese en los pedidos.
- 27/2** **Eingeklammerte Zahl = Dicke in mm.**
Number in brackets = thickness in mm.
Chiffre entre parenthèses = épaisseur en mm.
Cifra entre paréntesis = espesor en mm.
- 27/3** **Eingeklammerte Zahl = Zähnezahl.**
Number in brackets = number of teeth
Chiffre entre parenthèses = nombre de dents.
Cifra entre paréntesis = número de dientes.
- 27/5** **Eingeklammerte Zahl = Länge in mm.**
Number in brackets = length in mm.
Chiffre entre parenthèses = longueur en mm.
Cifra entre paréntesis = largura en mm.
- 35/3** **Bei (Nach) Montage verstemmen.**
End of part to be flattened out after assembly.
Mater après l'assemblage.
La pieza tiene que ser calafateada después de montada.
- 40/2** **Tränken mit 28-011 201-44; Bestellnummer siehe Seite 18 - 1.**
Grease with 28-011 201-44; for part number see page 18 - 1.
Graisser avec de la graisse 28-011 201-44; n° de commande, voir page 18 - 1.
Engrase con grasa 28-011 201-44; para el número de pedido véase la página 18 - 1.

- 40/3** **Fetten mit 28-011 202-47; Bestellnummer siehe Seite 18 - 1.**
Grease with 28-011 202-47; for part number see page 18 - 1.
Graisser avec de la graisse 28-011 202-47; n° de commande, voir page 18 - 1.
Engrase con grasa 28-011 202-47; para el número de pedido véase la página 18 - 1.
- 40/4** **Fetten mit 28-011 202-43; Bestellnummer siehe Seite 18 - 1.**
Grease with 28-011 202-43; for part number see page 18 - 1.
Graisser avec de la graisse 28-011 202-43; n° de commande, voir page 18 - 1.
Engrase con grasa 28-011 202-43; para el número de pedido véase la página 18 - 1.
- 40/5** **Ölen mit 28-011 201-44; Bestellnummer siehe Seite 18 - 1.**
Oil with 28-011 201-44; for part number see page 18 - 1.
Huiler par 28-011 201-44; n° de commande, voir page 18 - 1.
Lubrifique con 28-011 201-44; para el número de pedido véase la página 18 - 1.
- 40/13** **Fetten mit 28-011 202-05; Bestellnummer siehe Seite 18 - 1.**
Grease with 28-011 202-05; for part number see page 18 - 1.
Graisser avec de la graisse 28-011 202-05; n° de commande, voir page 18 - 1.
Engrase con grasa 28-011 202-05; para el número de pedido véase la página 18 - 1.
- 40/23** **Tränken mit 28-011 201-05; Bestellnummer siehe Seite 18 - 1.**
Grease with 28-011 201-05; for part number see page 18 - 1.
Graisser avec de la graisse 28-011 201-05; n° de commande, voir page 18 - 1.
Engrase con grasa 28-011 201-05; para el número de pedido véase la página 18 - 1.
- 81/3** **Verwendung je nach Bedarf.**
To be used as required.
Utilisation en fonction des besoins.
Utilización, según sea necesario.
- 90/72** **Antrieb X-Achse links.**
Drive x-axis left.
Commande de l'axe des X gauche.
Accionamiento eje X izquierda.
- 90/73** **Antrieb X-Achse rechts.**
Drive x-axis right.
Commande de l'axe des X droit.
Accionamiento eje X derecha.
- 96** **Länge angeben.**
State length.
Préciser longueur.
Indíquese la largura.

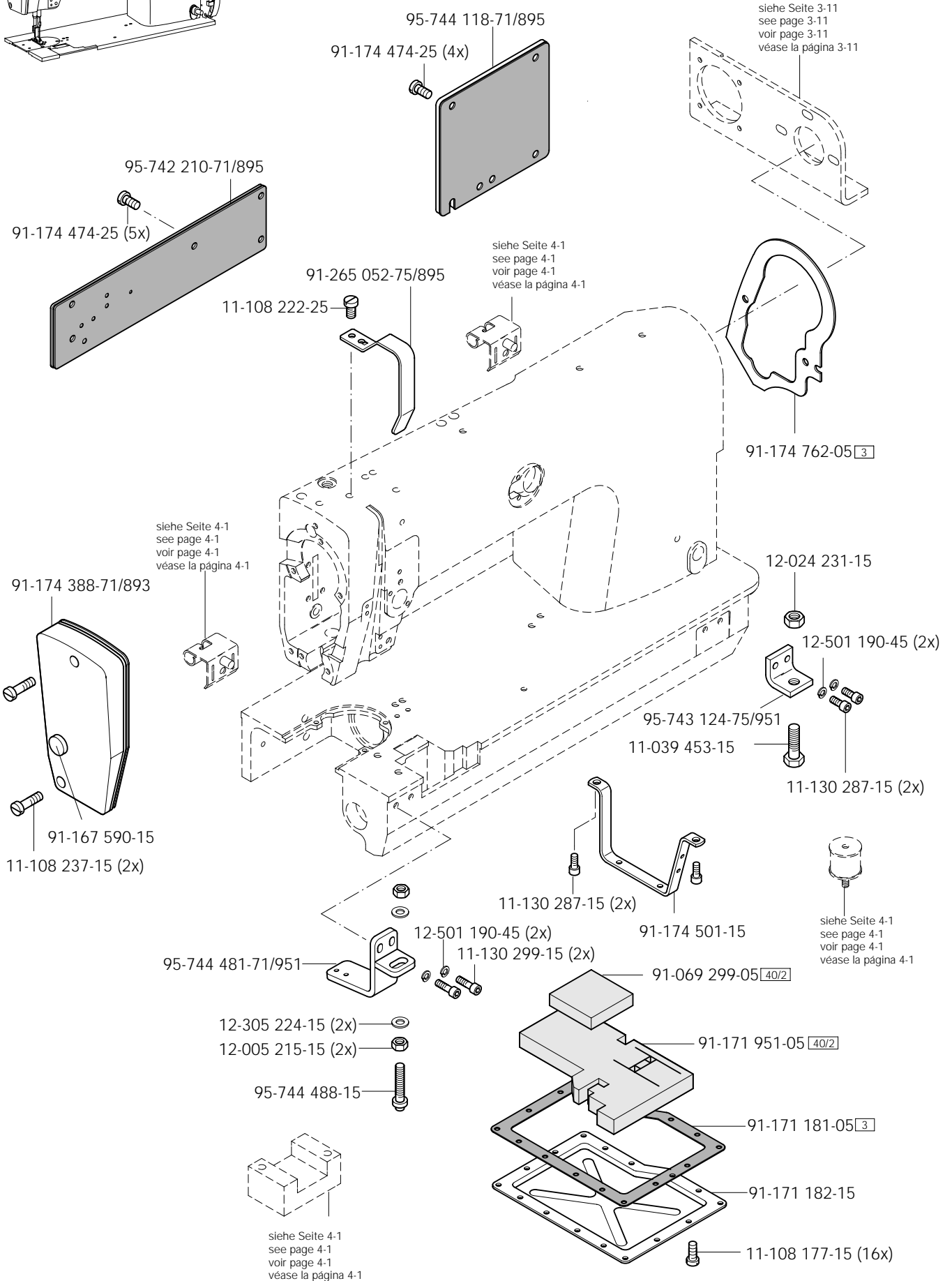
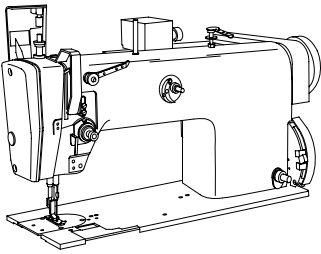

3.02

Kopfteile Needle head parts Pièces de tête Piezas de la cabeza PFAFF 3519-3/12

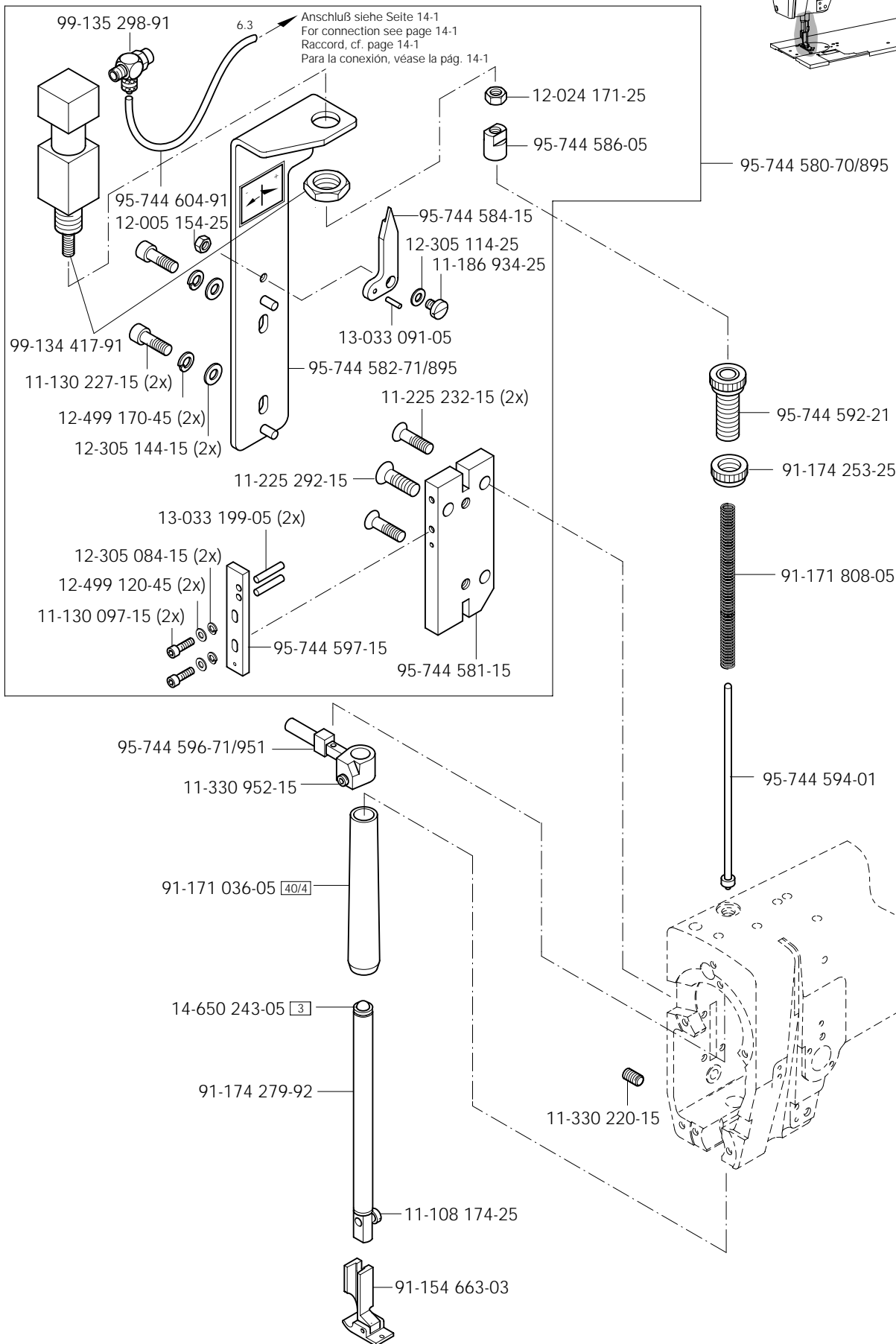
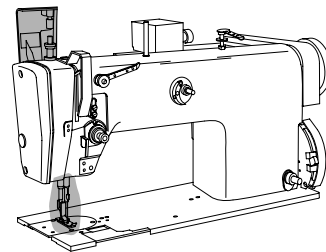

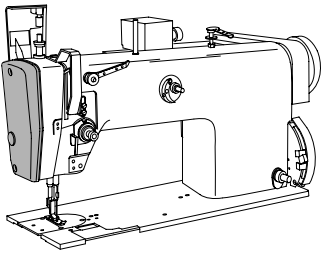

Kopfteile
 Needle head parts
 Pièces de tête
 Piezas de la cabeza PFAFF 3519-3/12

3.02

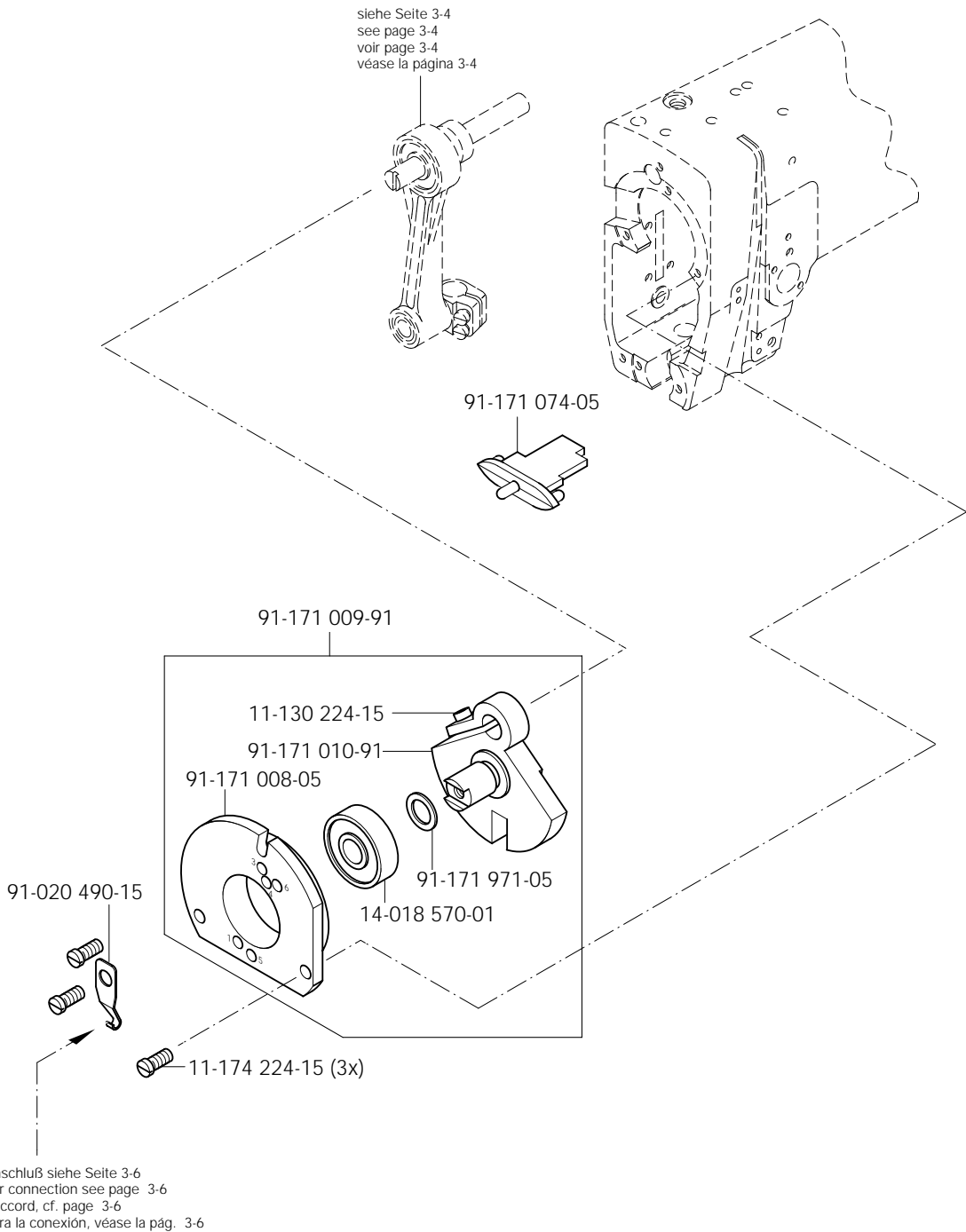

3.02

Kopfteile
Needle head parts
Pièces de tête
Piezas de la cabeza PFAFF 3519-3/12

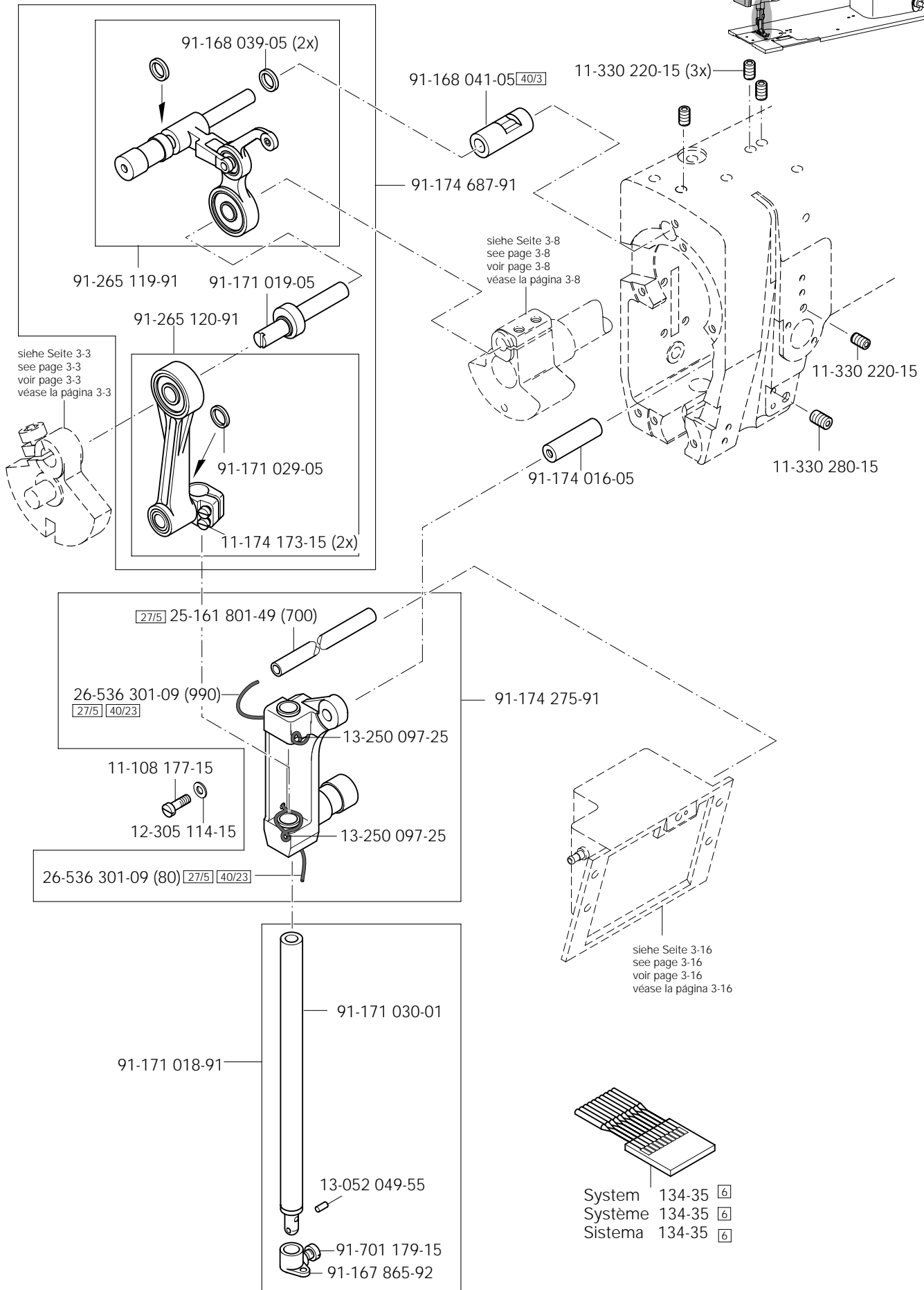
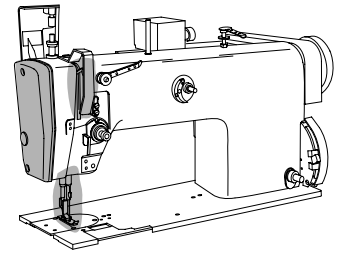

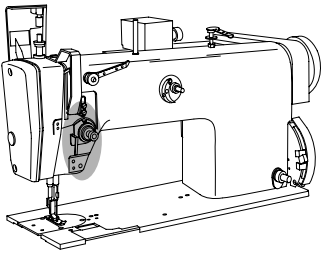

Kopfteile
 Needle head parts
 Pièces de tête
 Piezas de la cabeza PFAFF 3519-3/12

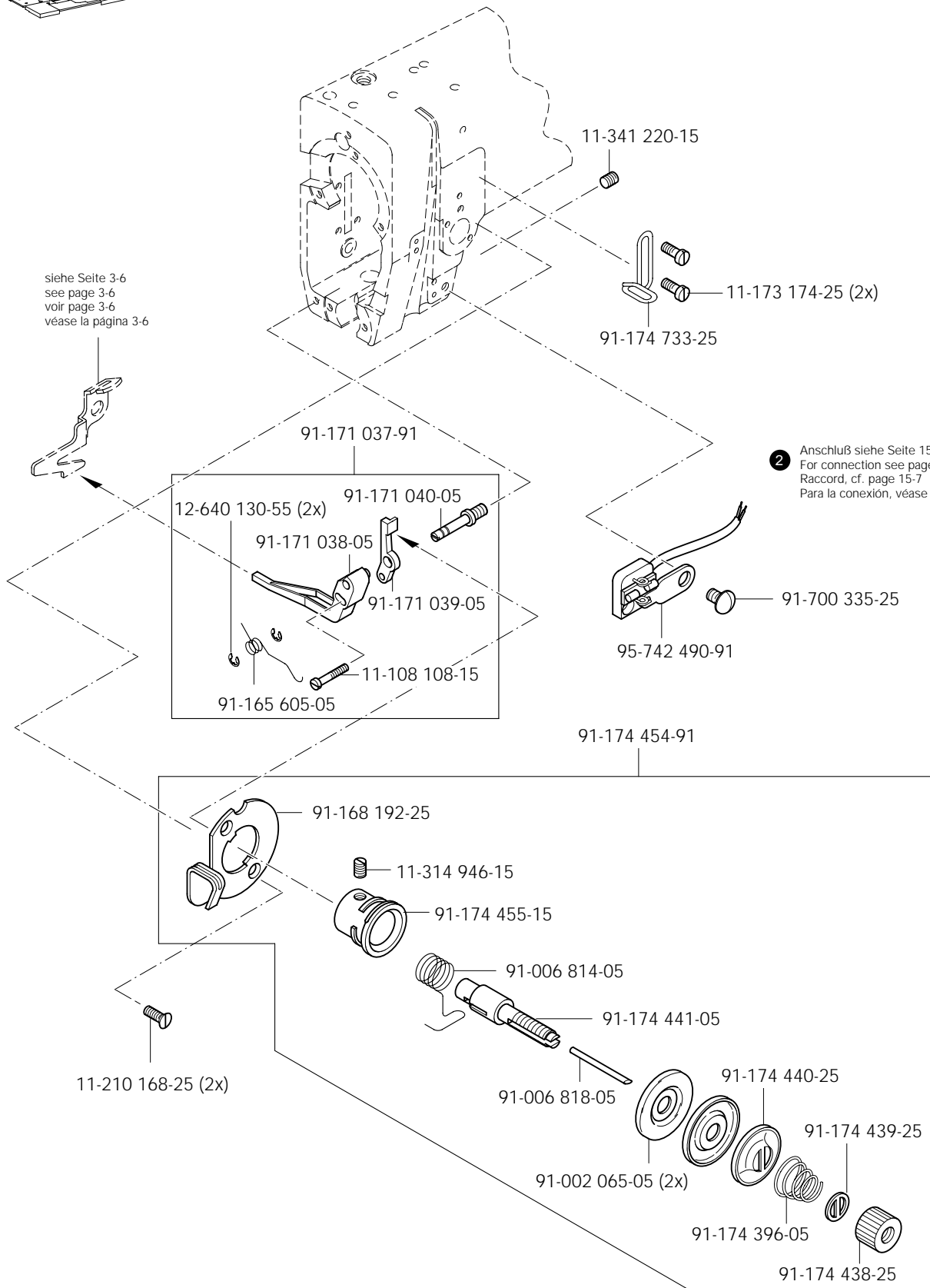

3.02

Kopfteile Needle head parts Pièces de tête Piezas de la cabeza PFAFF 3519-3/12

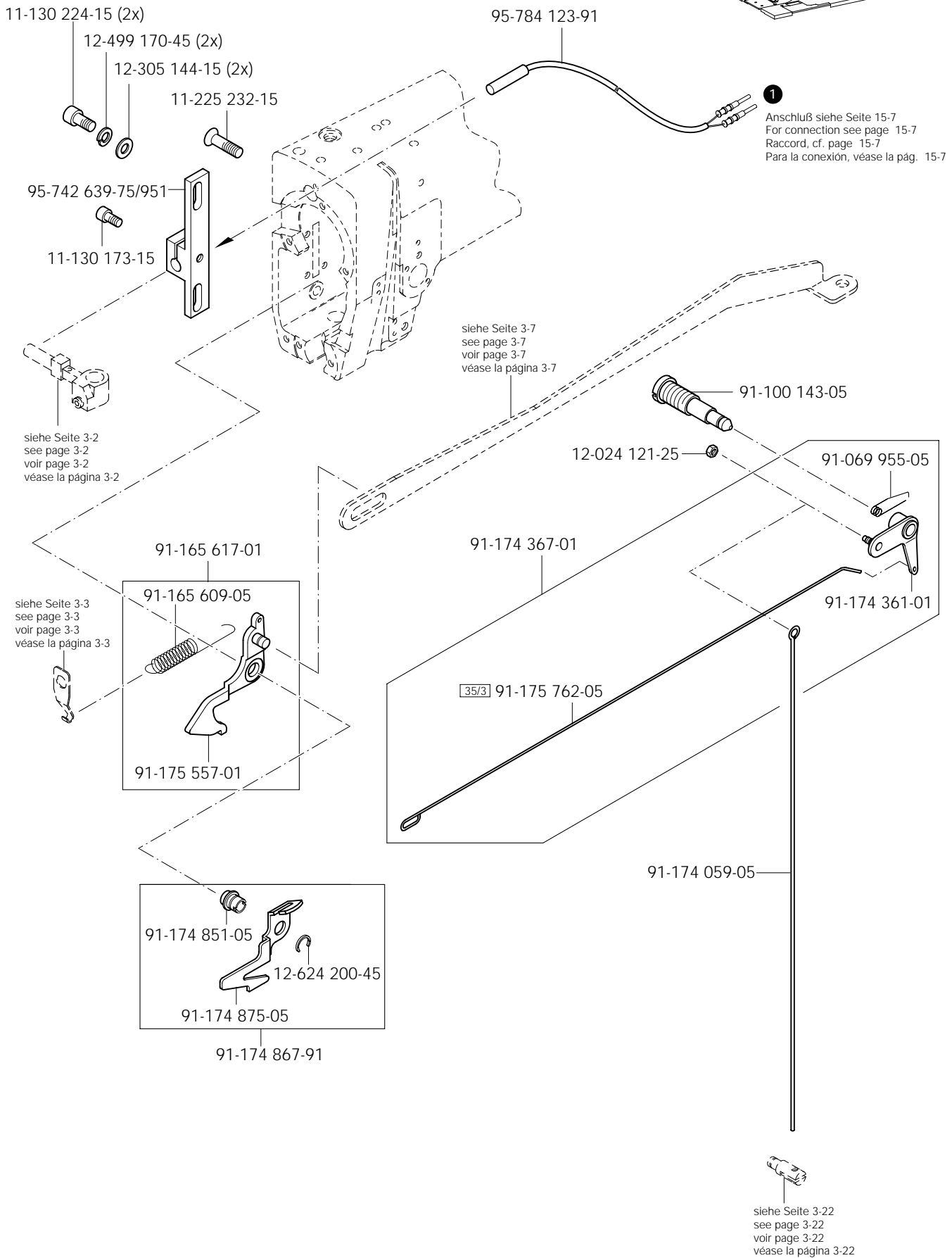
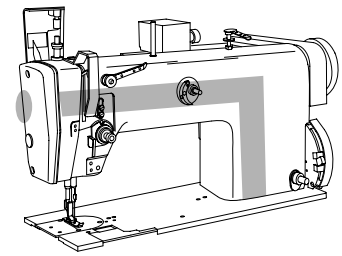

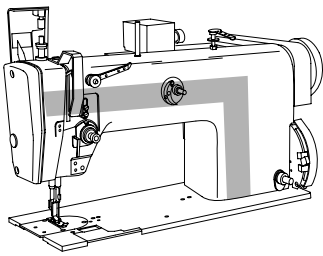

siehe Seite 3-6
 see page 3-6
 voir page 3-6
 véase la página 3-6

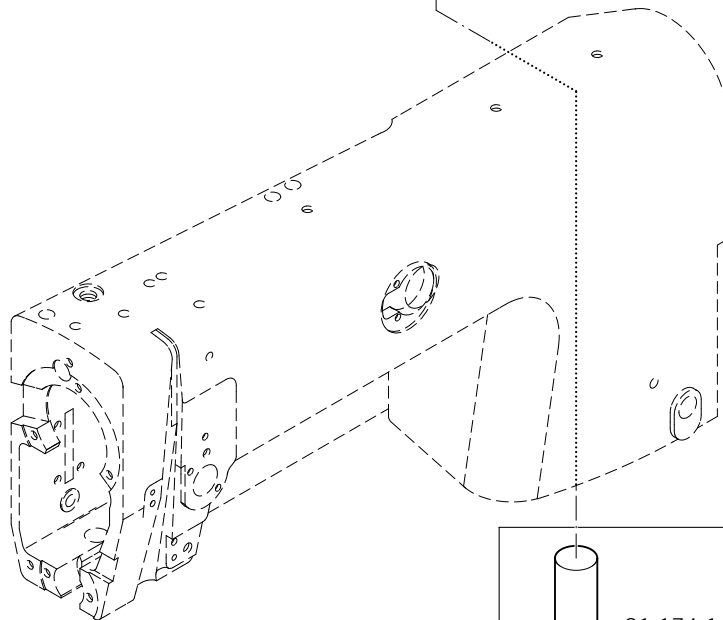
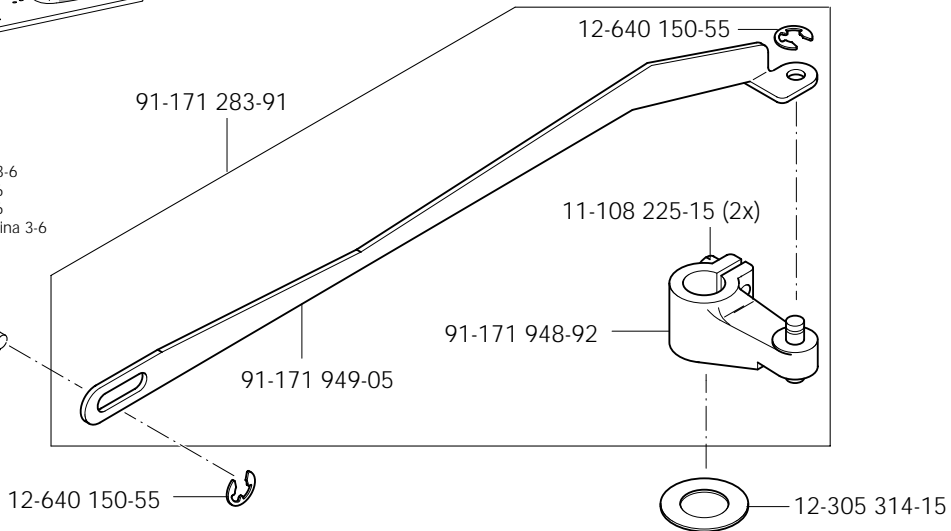

(2x) 12-024 191-15

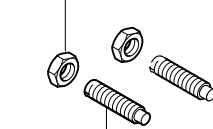

(2x) 11-305 299-15

91-171 540-91

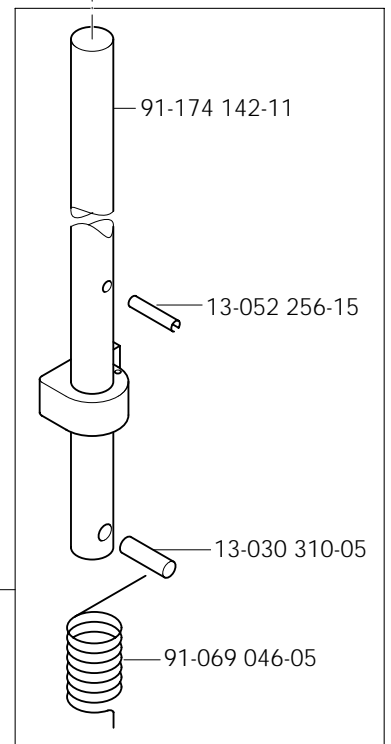

3.03

Armteile Arm parts Pièces de bras Piezas del brazo PFAFF 3519-3/12

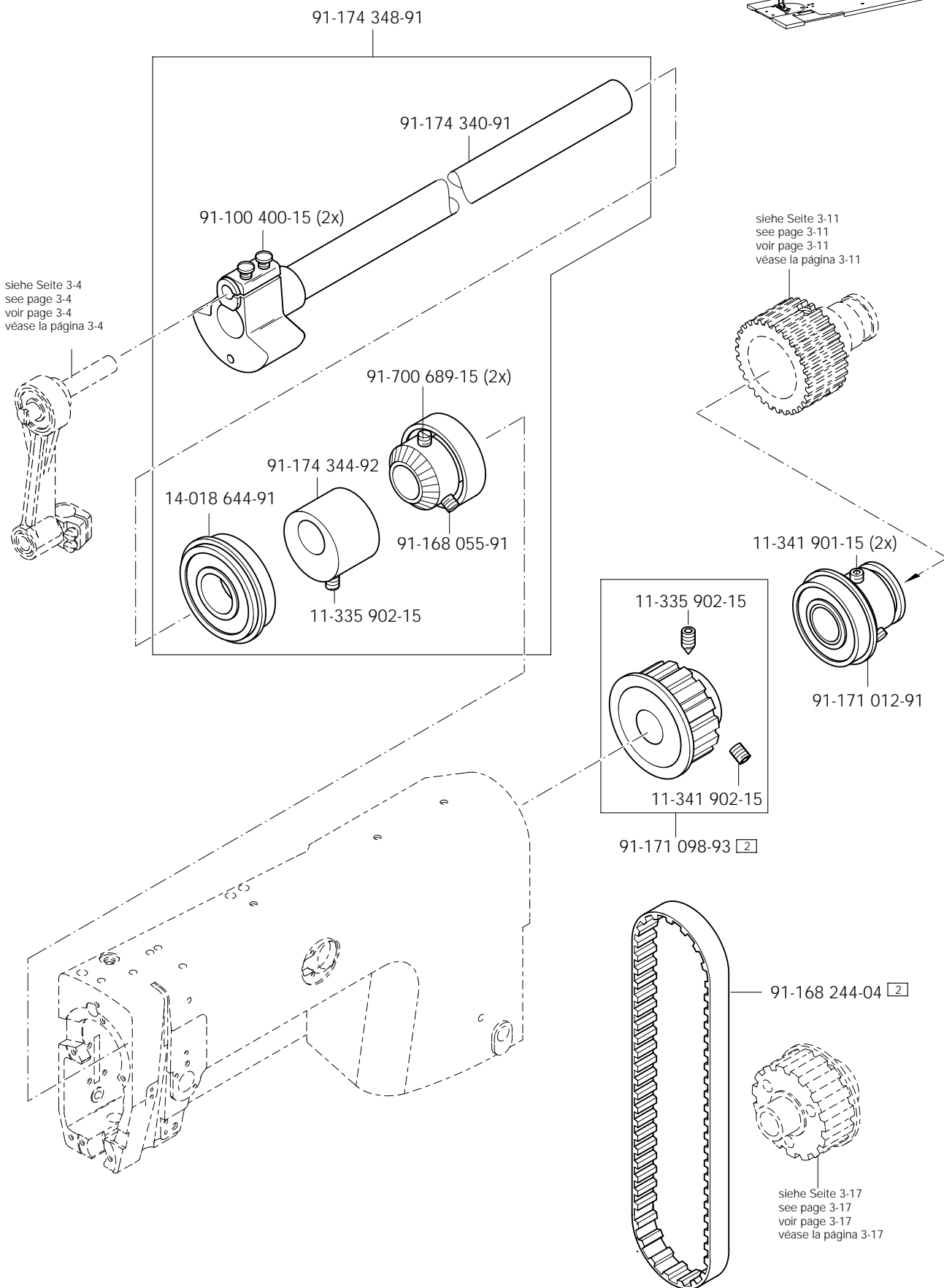
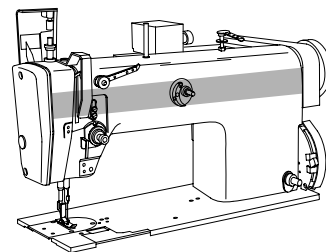

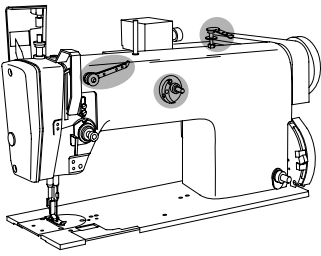

Armteile
 Arm parts
 Pièces de bras
 Piezas del brazo PFAFF 3519-3/12

3.03

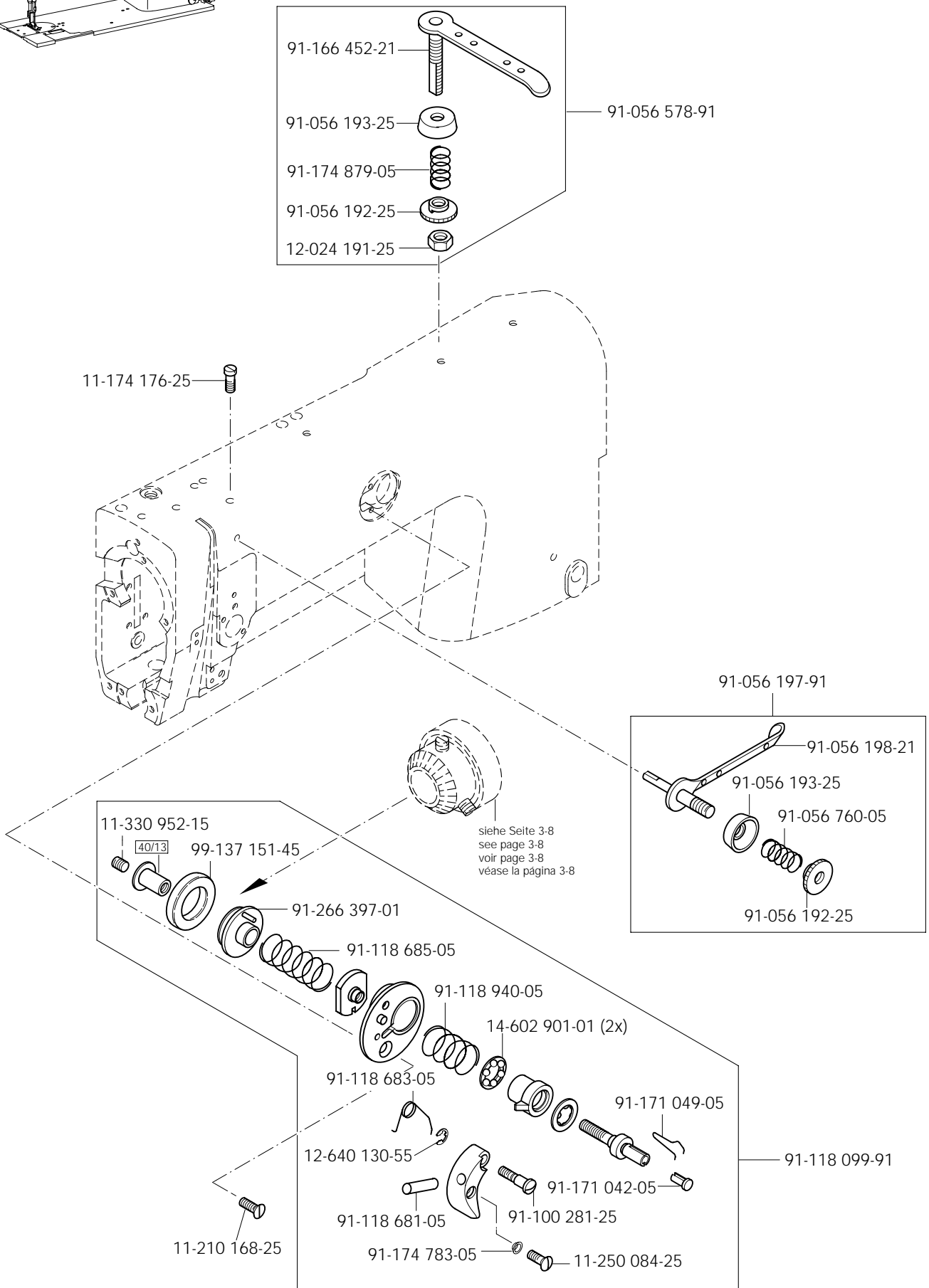

3.03

Armteile Arm parts Pièces de bras Piezas del brazo PFAFF 3519-3/12

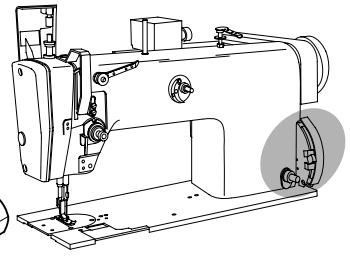

Anschluß siehe Seite 3-12
For connection see page 3-12
Raccord, cf. page 3-12
Para la conexión, véase la pág. 3-12

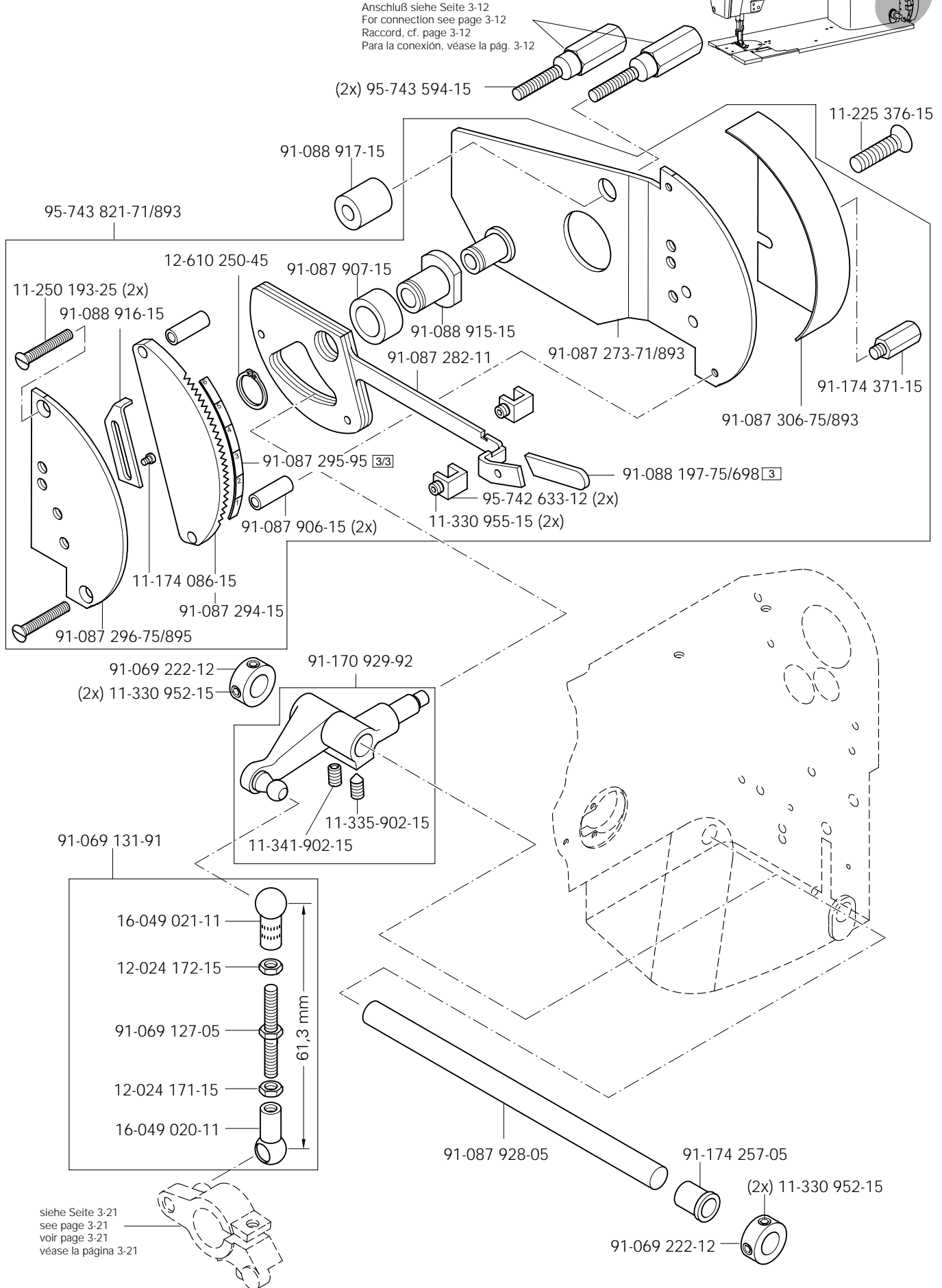

Armteile
 Arm parts
 Pièces de bras
 Piezas del brazo PFAFF 3519-3/12

3.03

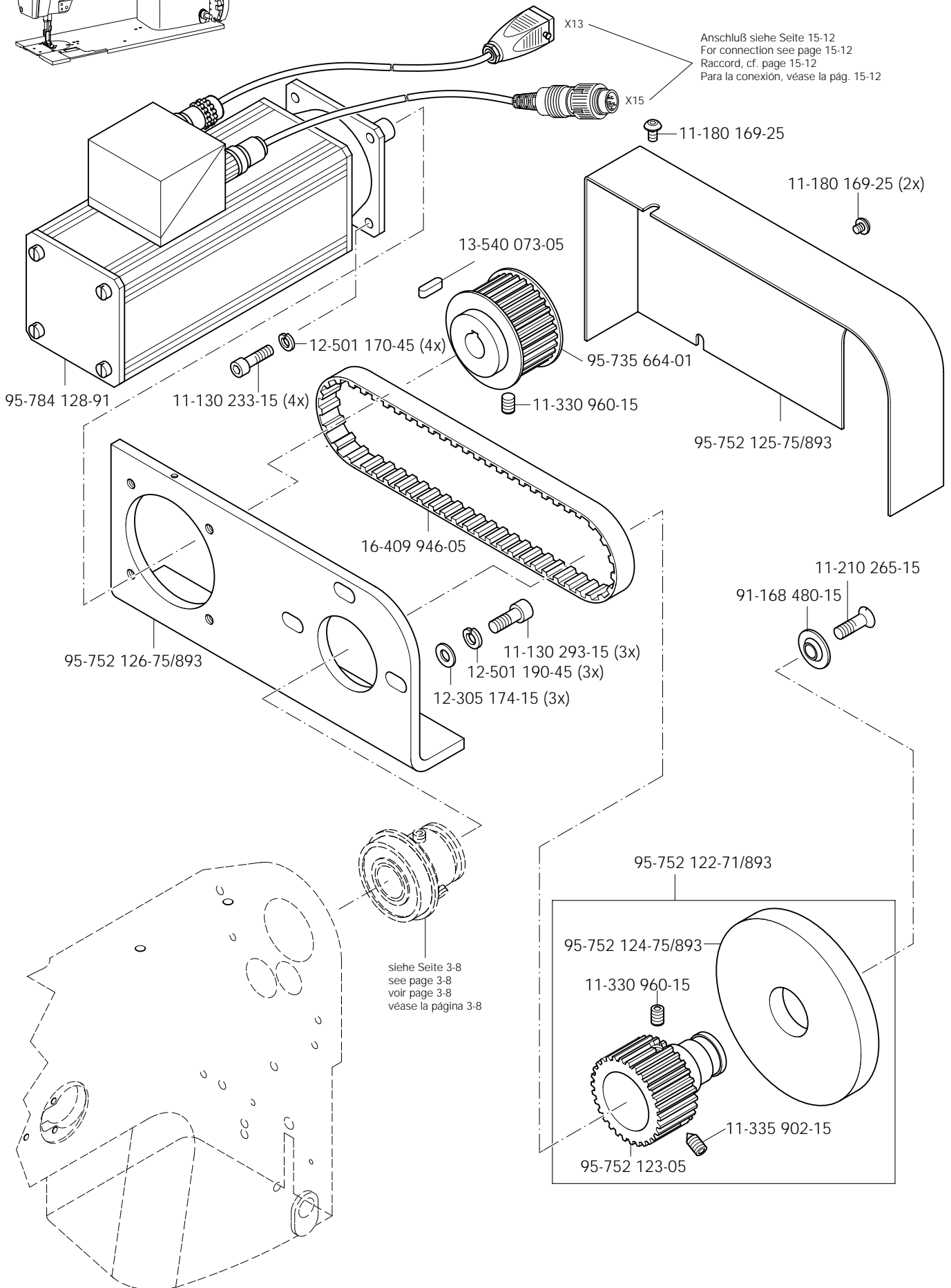

Anschluß siehe Seite 15-12
 For connection see page 15-12
 Raccord, cf. page 15-12
 Para la conexión, véase la pág. 15-12

siehe Seite 3-8
 see page 3-8
 voir page 3-8
 véase la página 3-8

3.03

Armteile
 Arm parts
 Pièces de bras
 Piezas del brazo PFAFF 3519-3/12

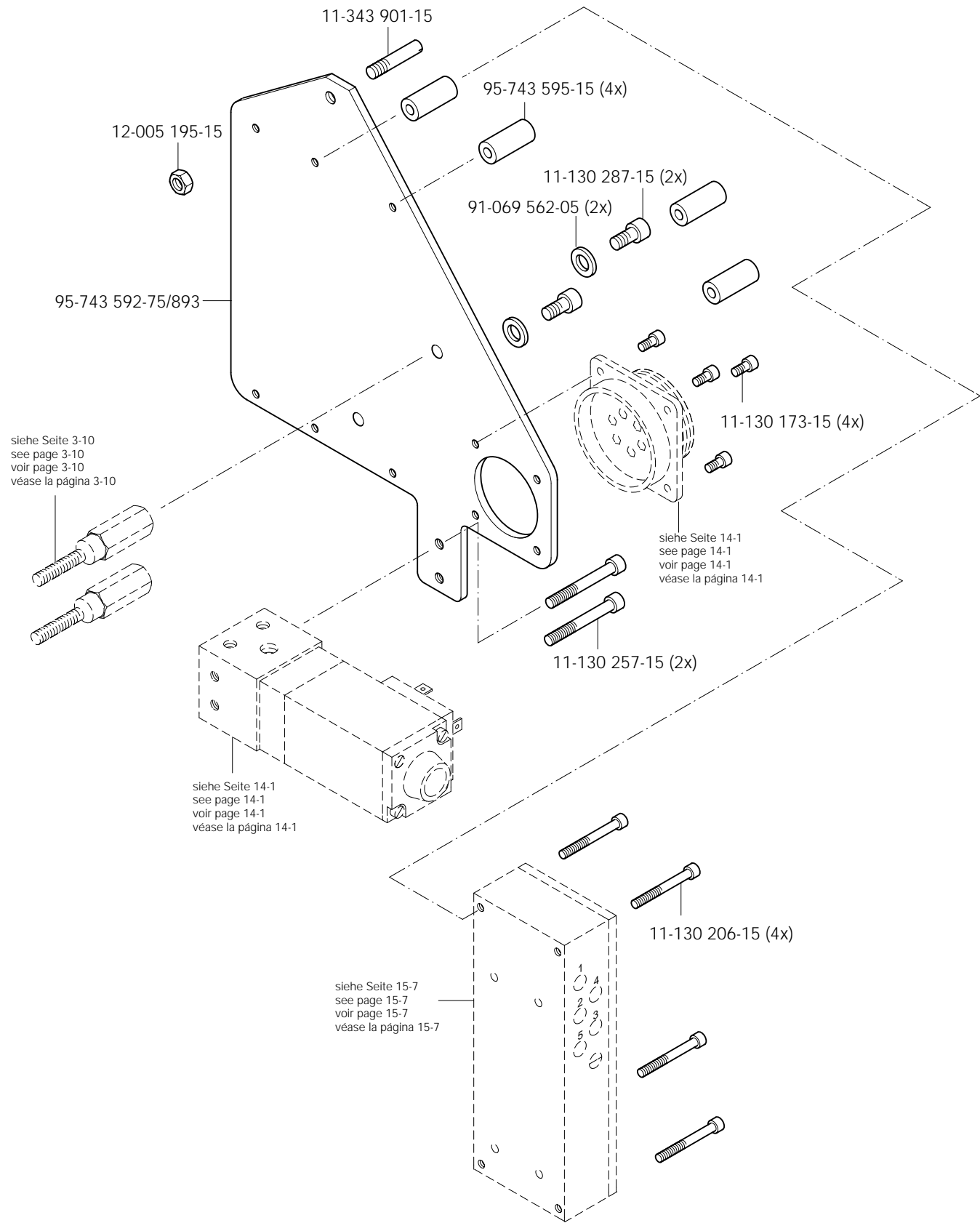
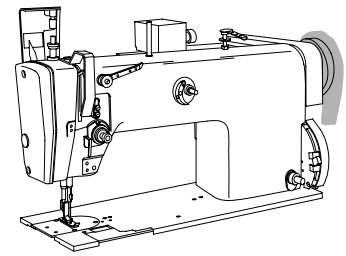

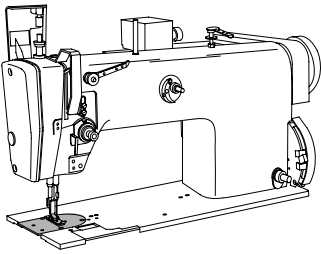

Grundplattenteile
 Bedplate parts
 Pièces du plateau fondamental
 Piezas del cárter

PFAFF 3519-3/12

3.04

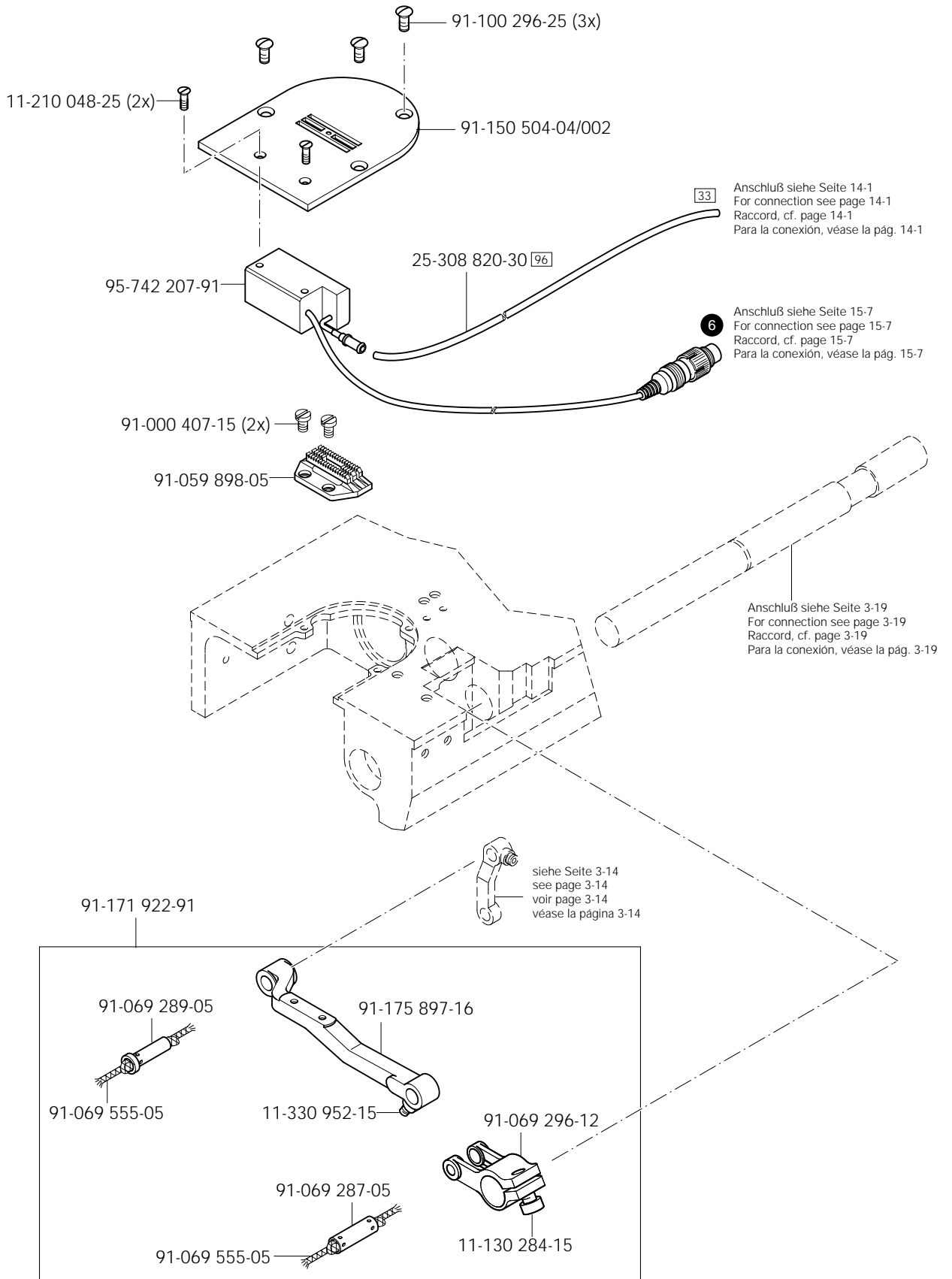

3.04

Grundplattenteile
Bedplate parts
Pièces du plateau fondamental
Piezas del cárter

PFAFF 3519-3/12

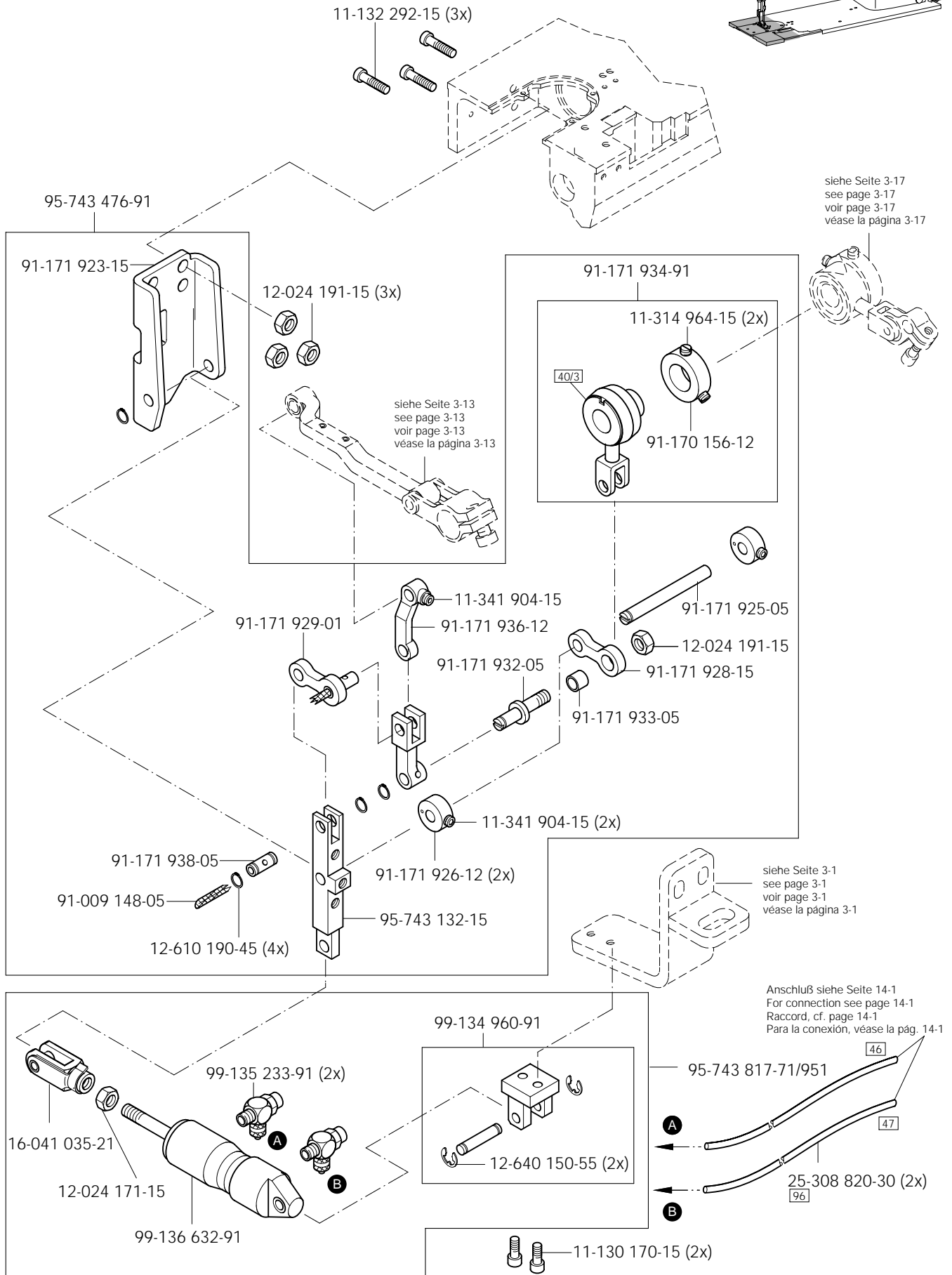
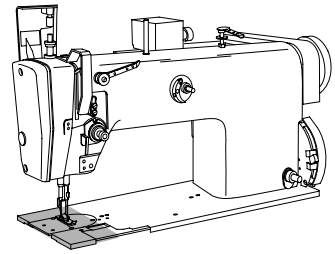

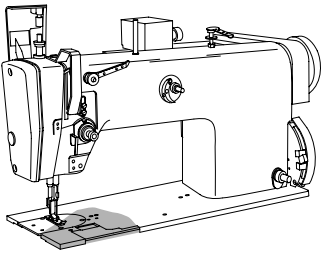

Grundplattenteile
 Bedplate parts
 Pièces du plateau fondamental
 Piezas del cárter

PFAFF 3519-3/12

3.04

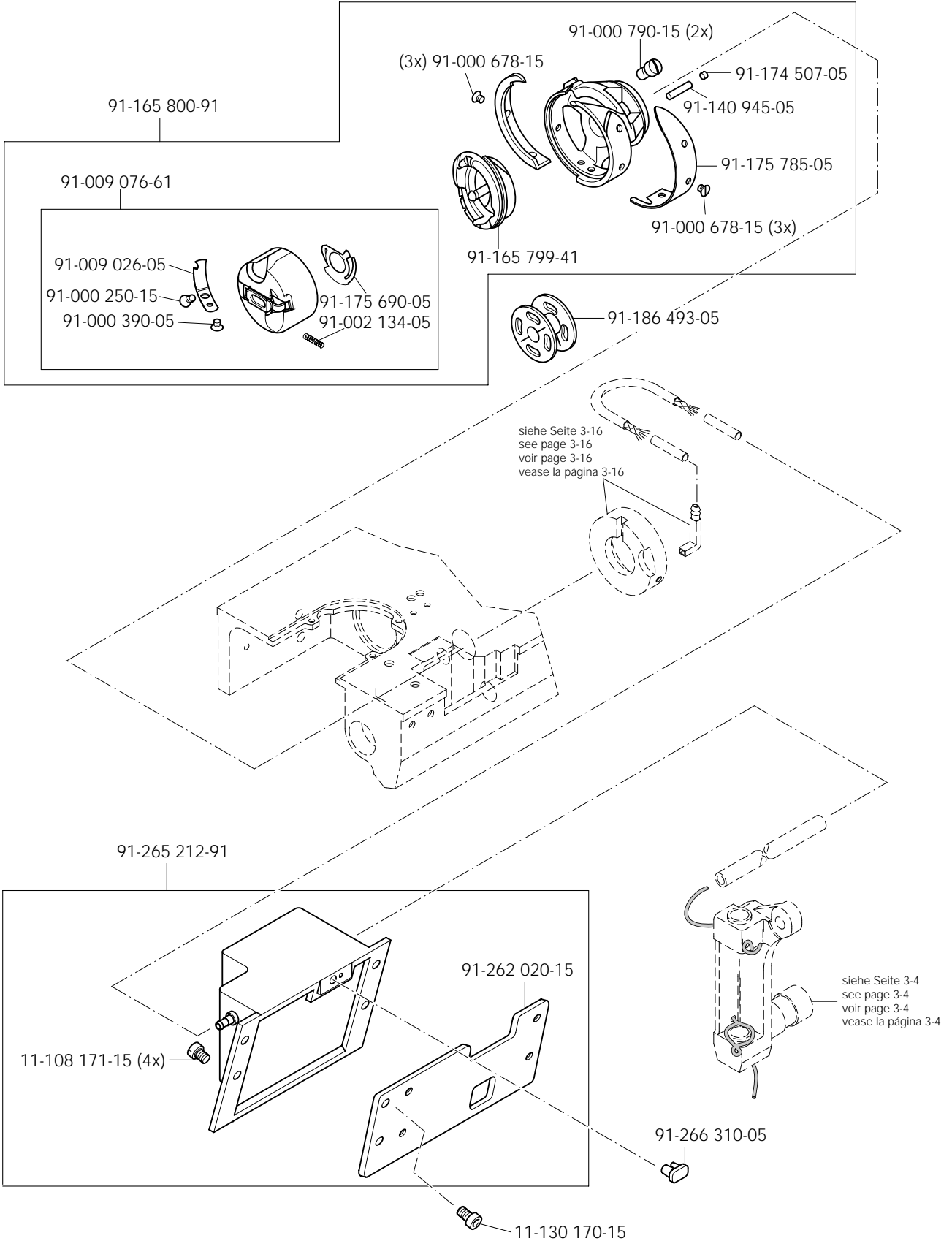

3.04

Grundplattenteile Bedplate parts Pièces du plateau fondamental Piezas del cárter

PFAFF 3519-3/12

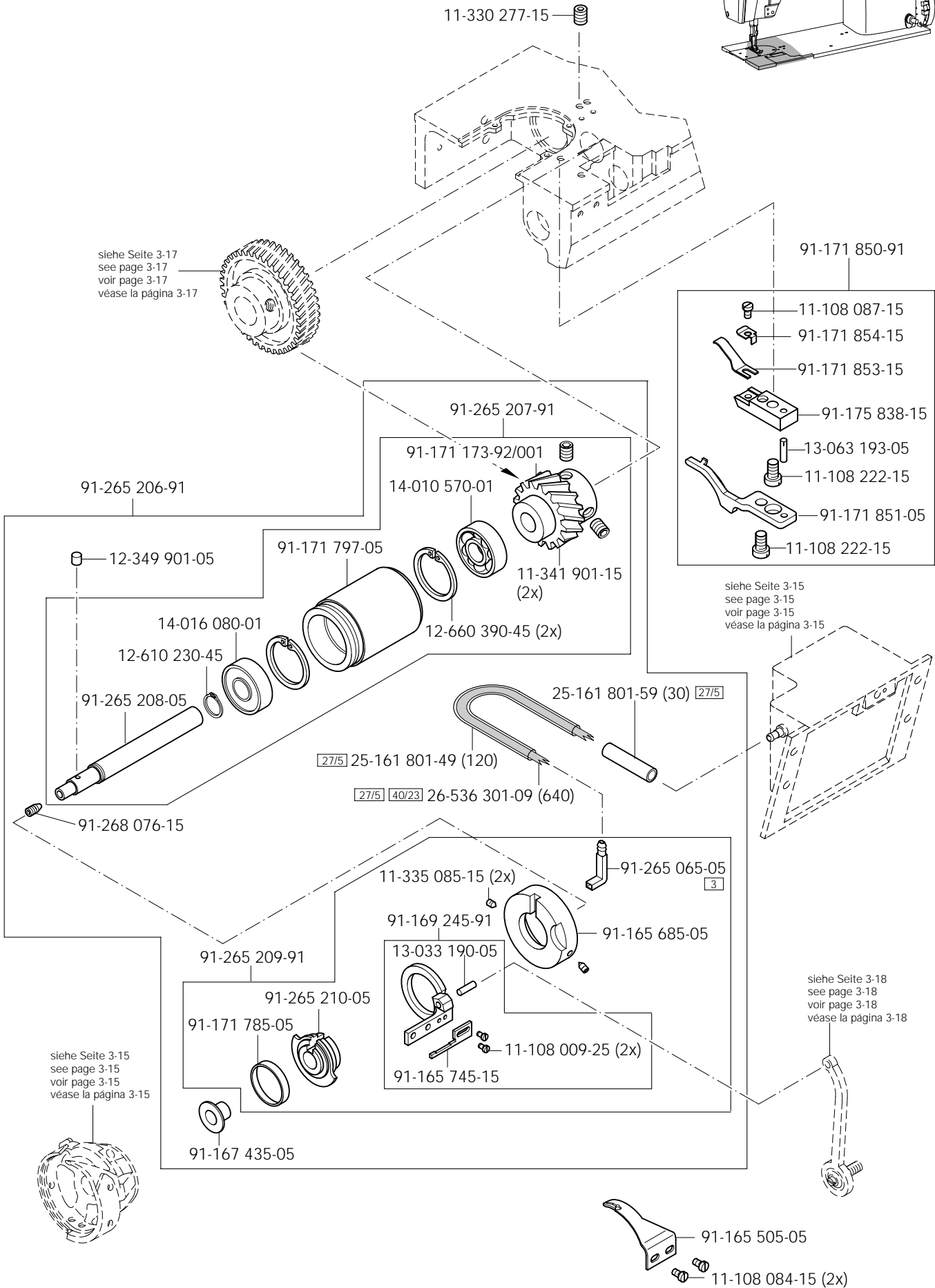
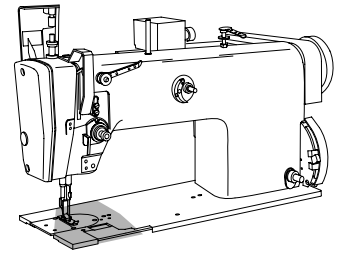

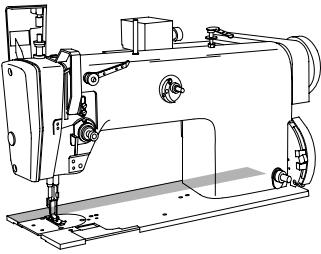

Grundplattenteile
Bedplate parts
Pièces du plateau fondamental
Piezas del cárter

PFAFF 3519-3/12

3.04

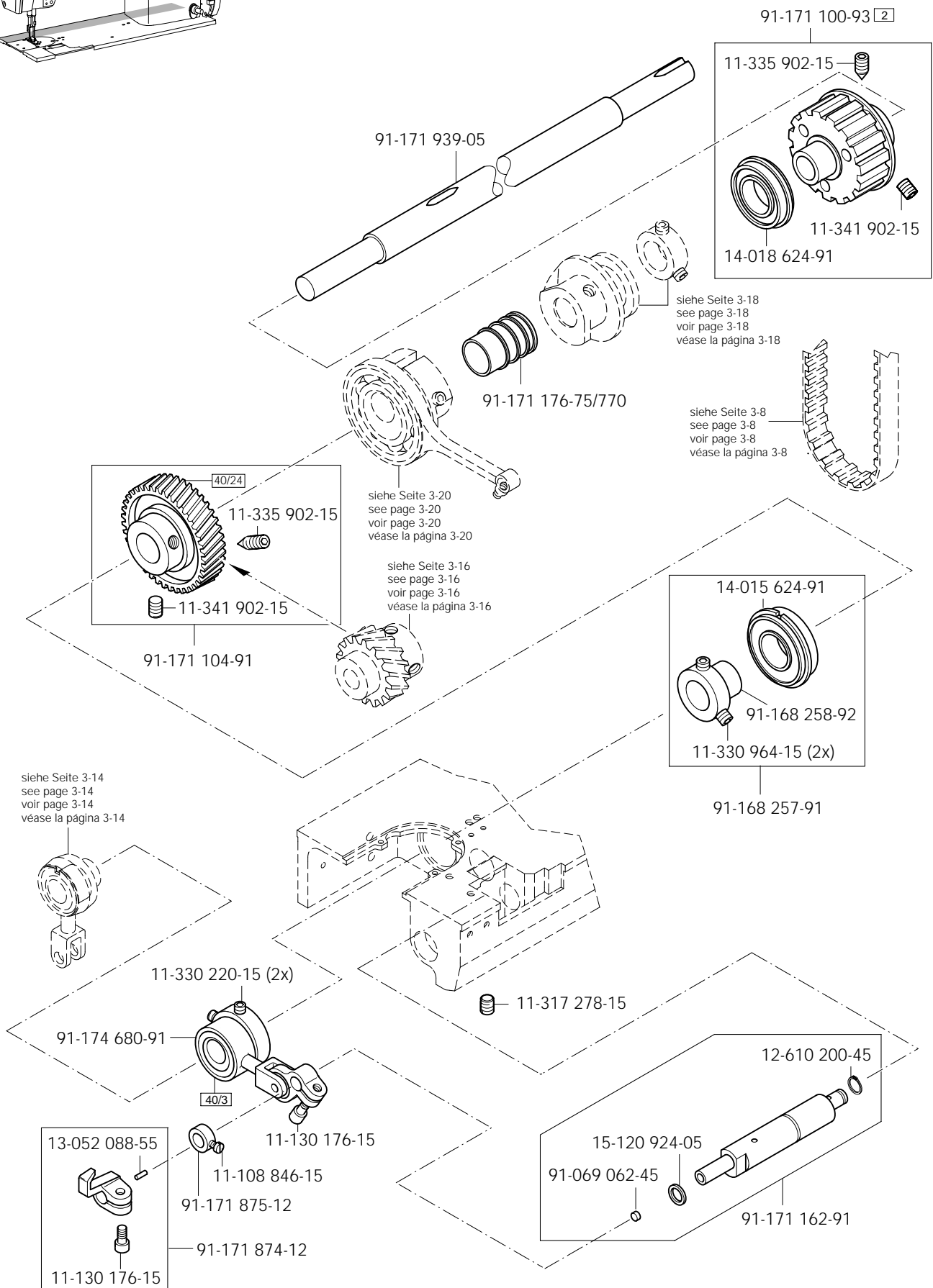

3.04

Grundplattenteile
Bedplate parts
Pièces du plateau fondamental
Piezas del cárter

PFAFF 3519-3/12

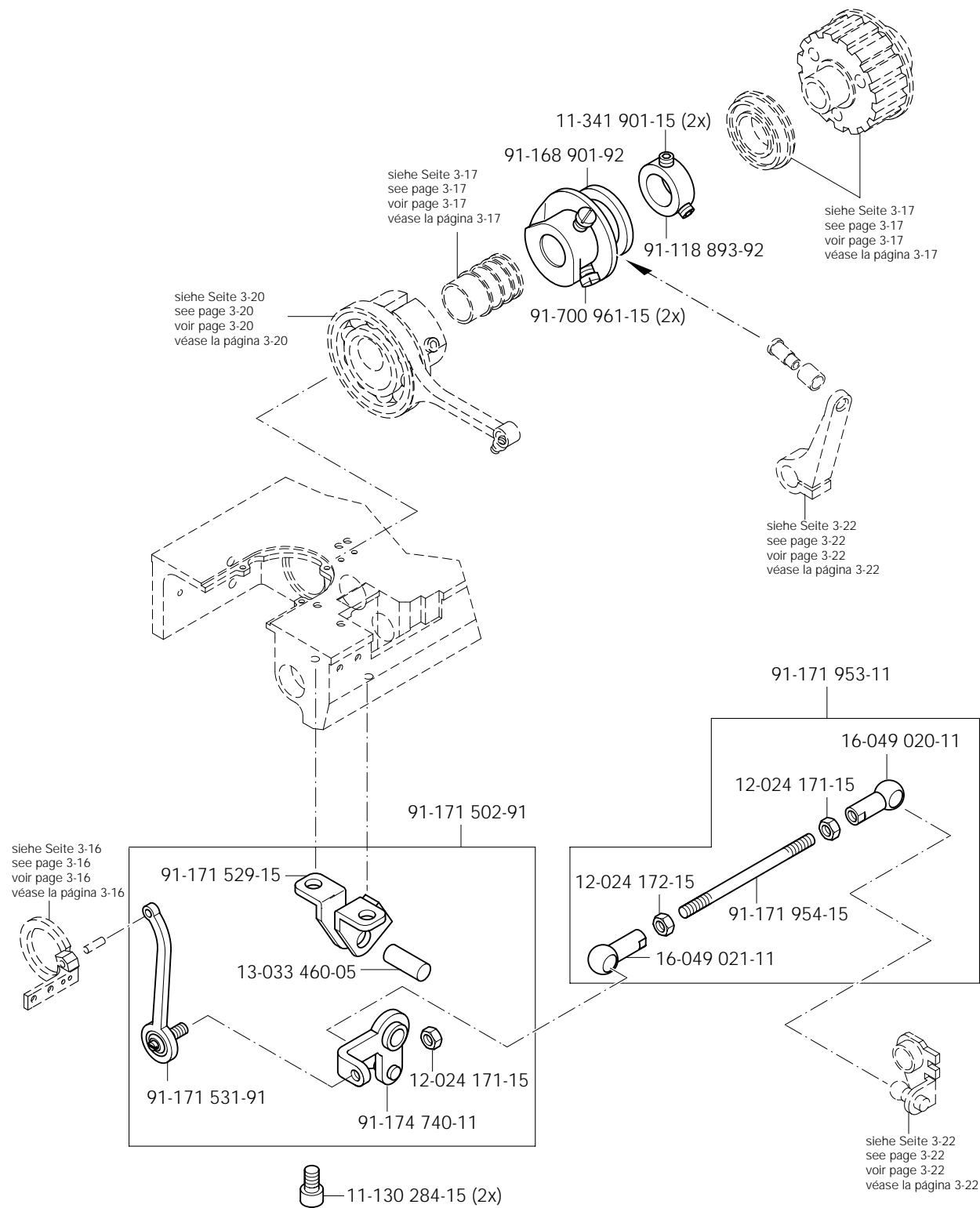
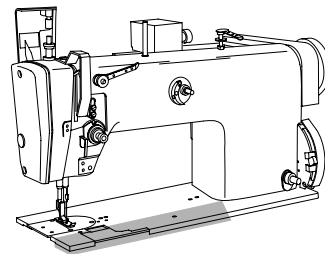

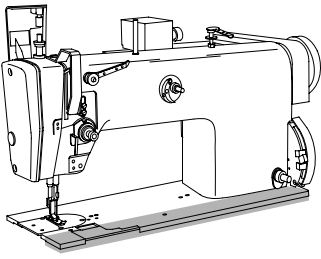

Grundplattenteile
 Bedplate parts
 Pièces du plateau fondamental
 Piezas del cárter

PFAFF 3519-3/12

3.04

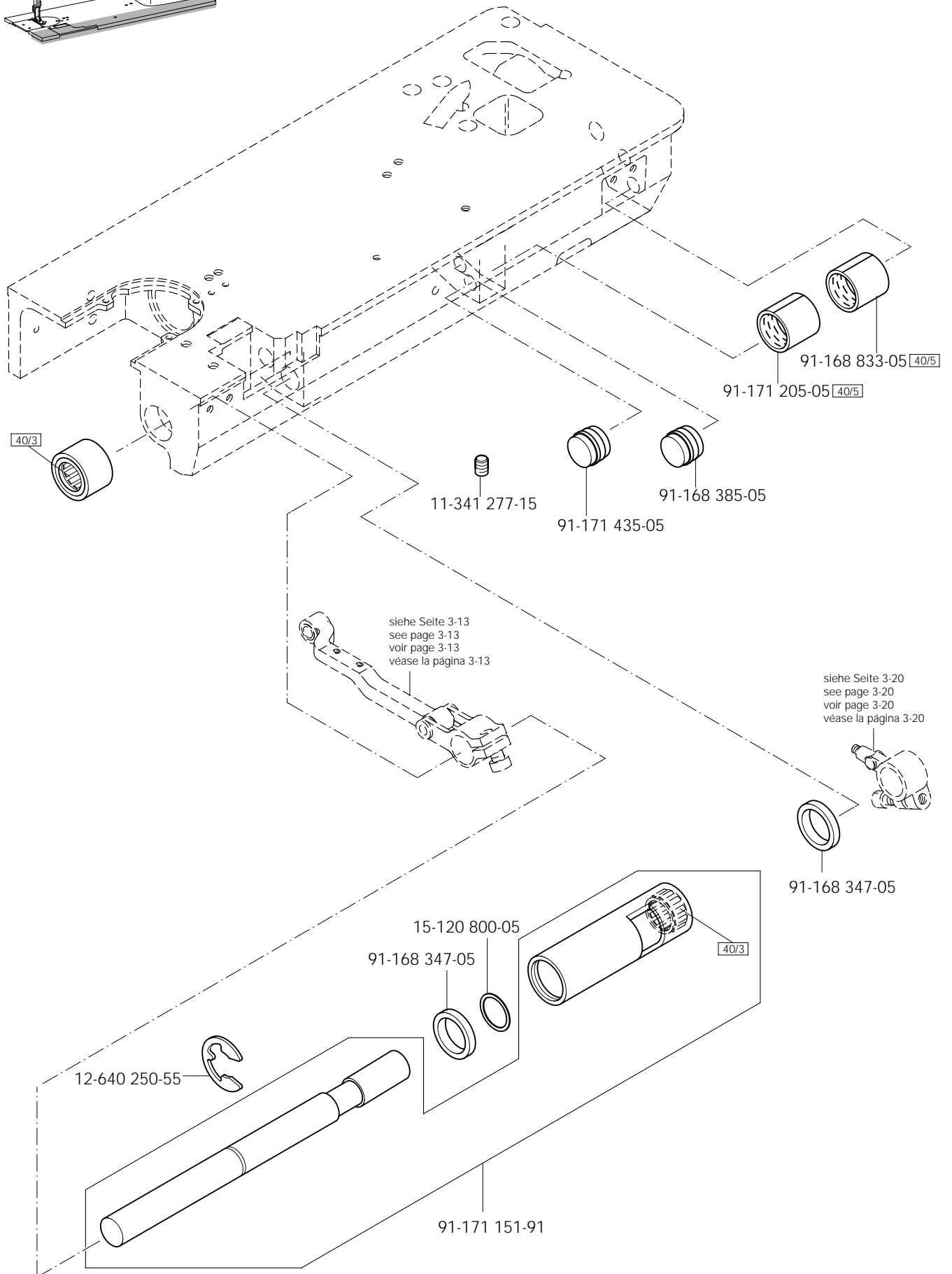

3.04

Grundplattenteile
 Bedplate parts
 Pièces du plateau fondamental
 Piezas del cárter

PFAFF 3519-3/12

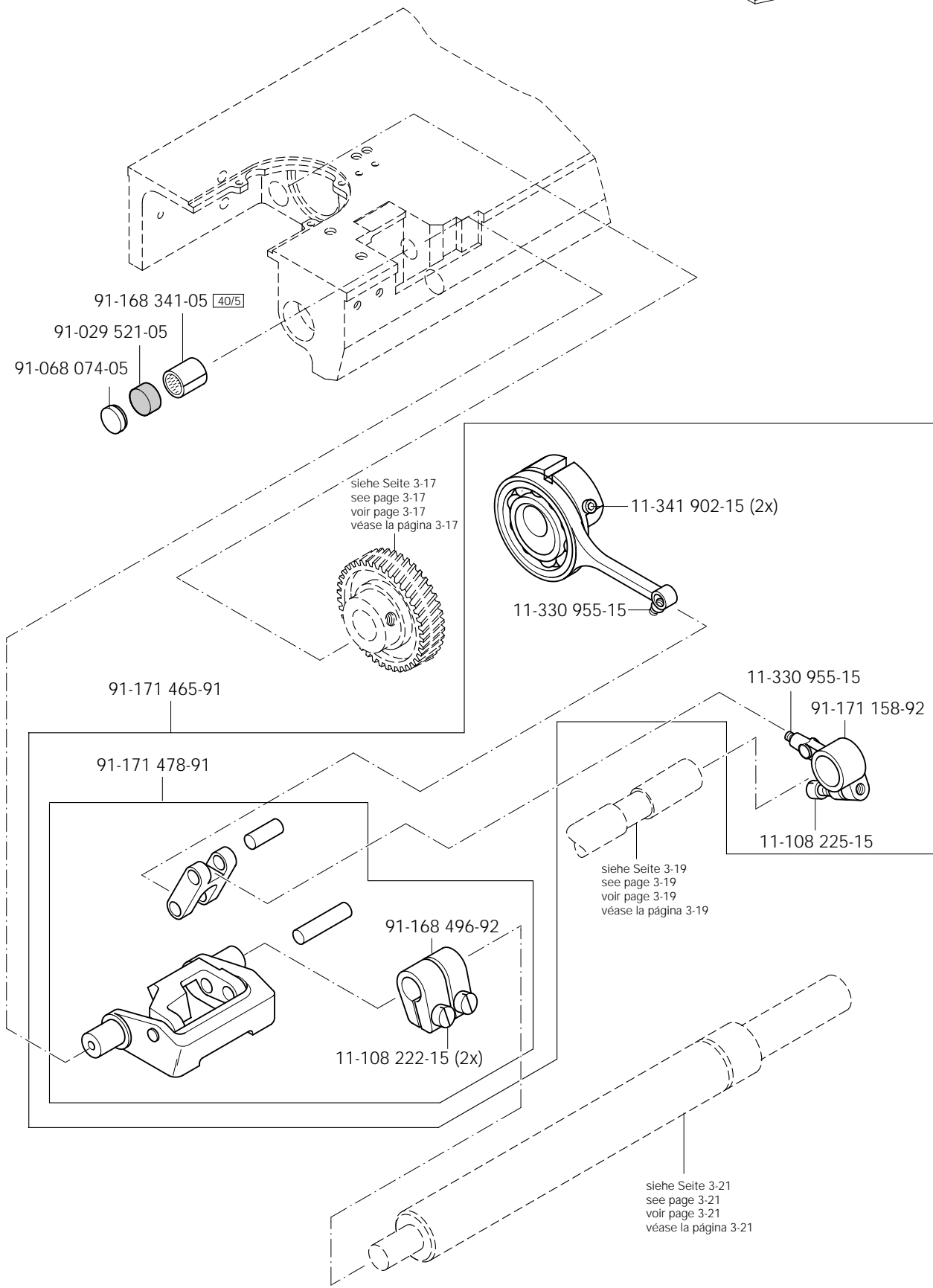
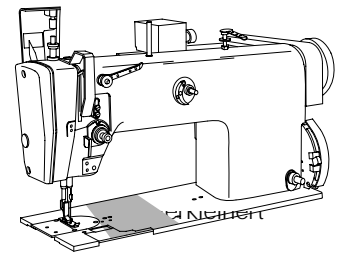

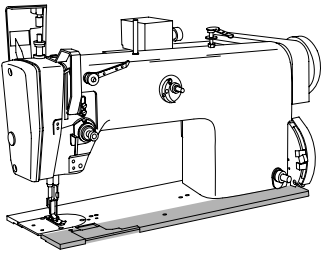

Grundplattenteile
 Bedplate parts
 Pièces du plateau fondamental
 Piezas del cárter

PFAFF 3519-3/12

3.04

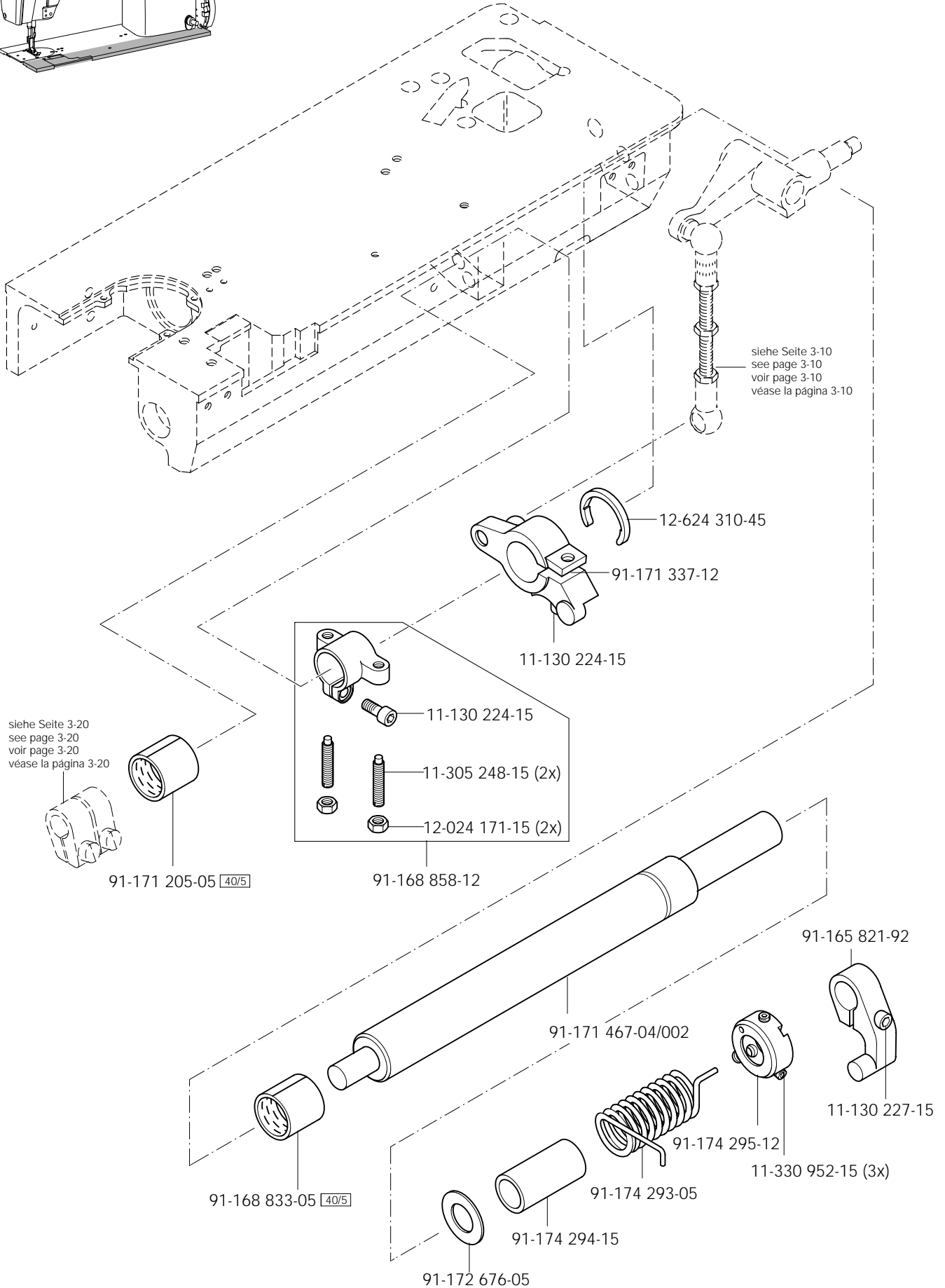

3.04

Grundplattenteile Bedplate parts Pièces du plateau fondamental Piezas del cárter

PFAFF 3519-3/12

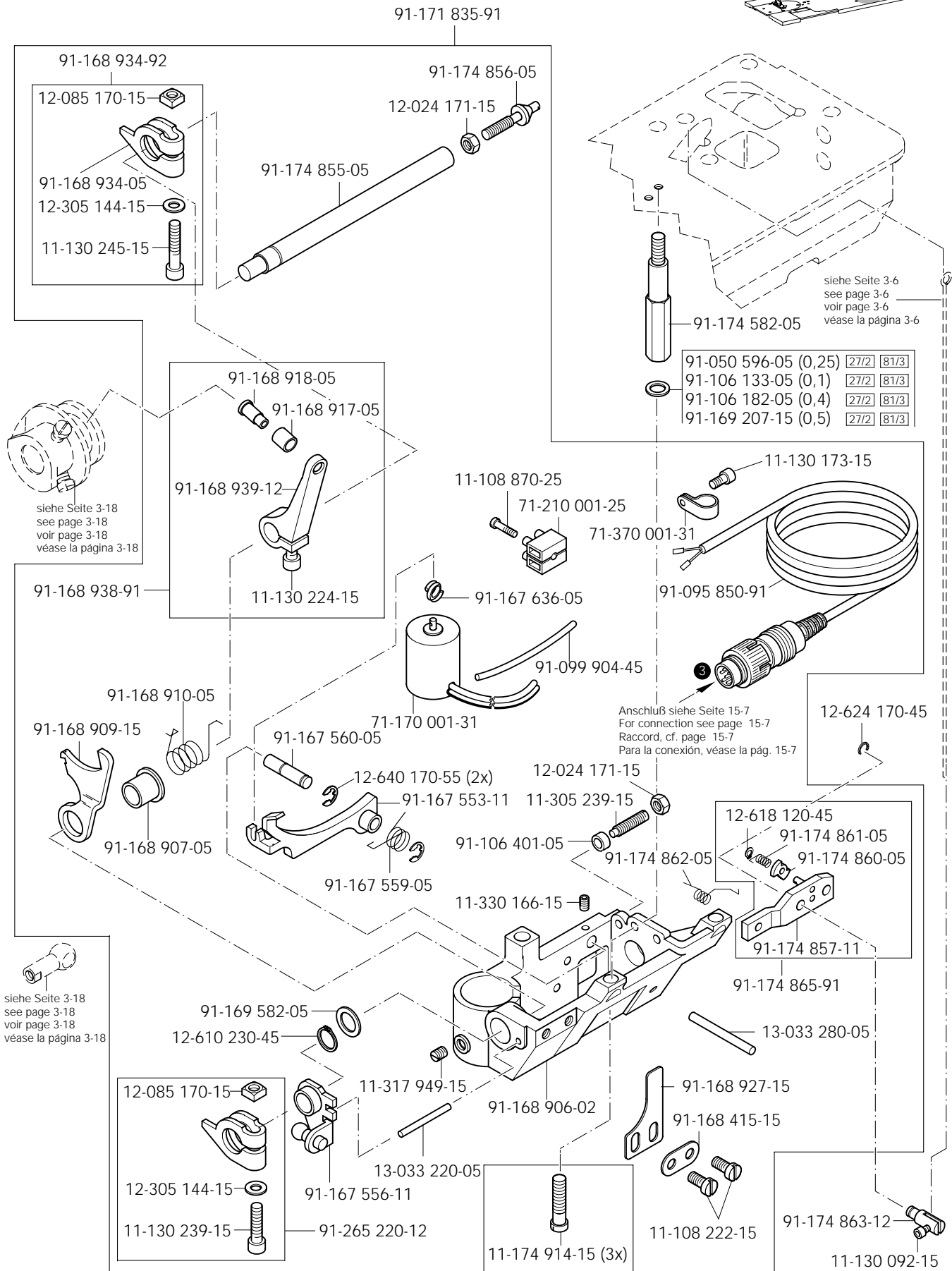
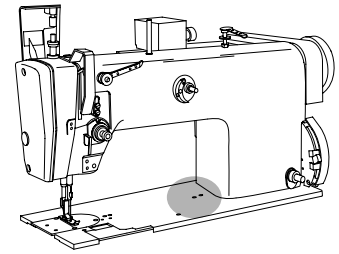

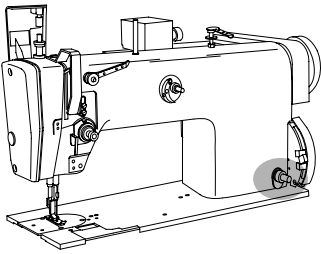

Grundplattenteile
 Bedplate parts
 Pièces du plateau fondamental
 Piezas del cárter

PFAFF 3519-3/12

3.04

Anschluß siehe Seite 14-1
 For connection see page 14-1
 Raccord, cf. page 14-1
 Para la conexión, véase la pág. 14-1

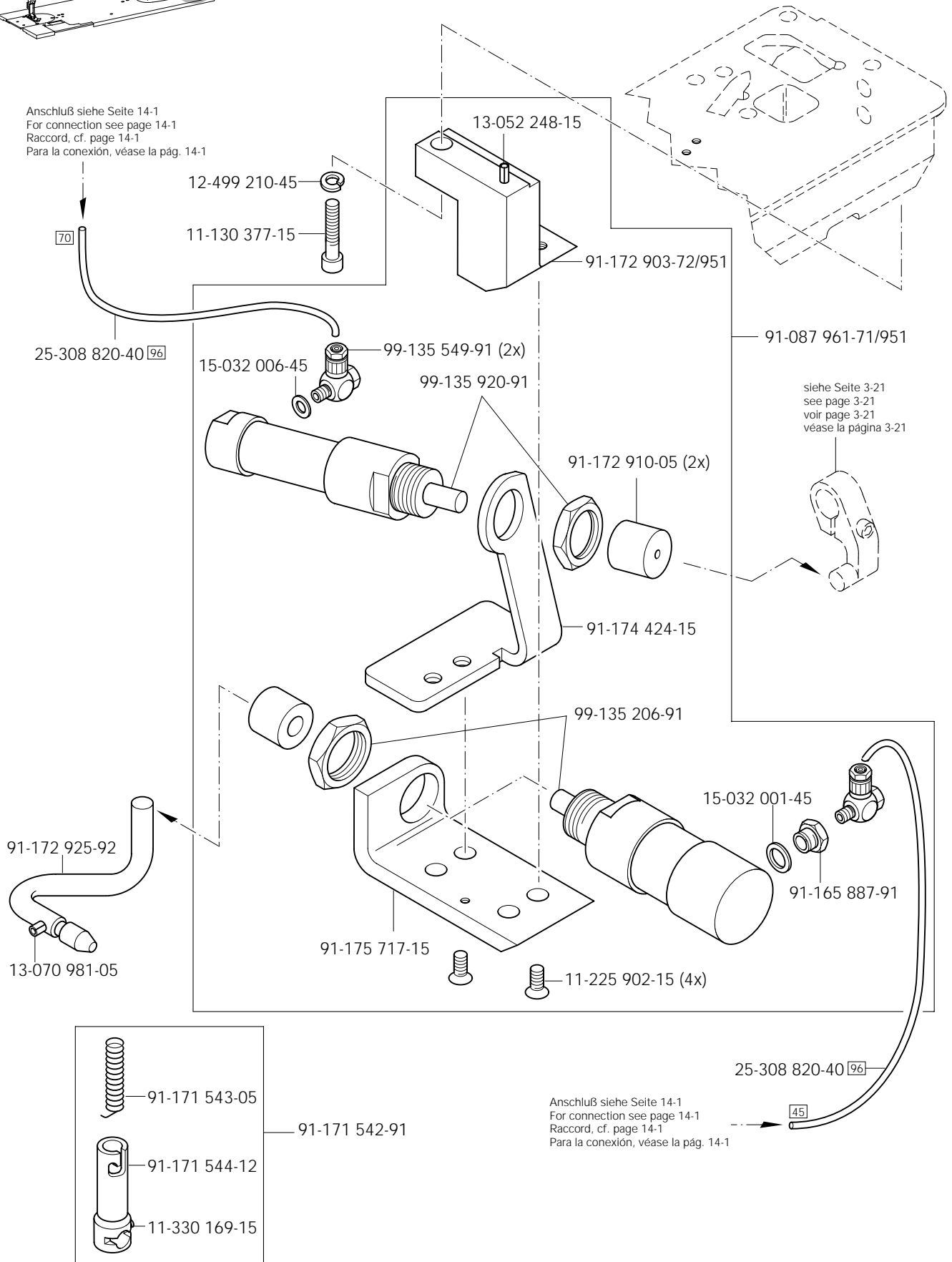

4

Oberteilführung
Sewing head guide
Guide de tête
Guía de parte superior PFAFF 3519-3/12

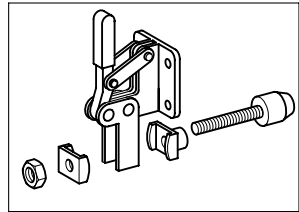
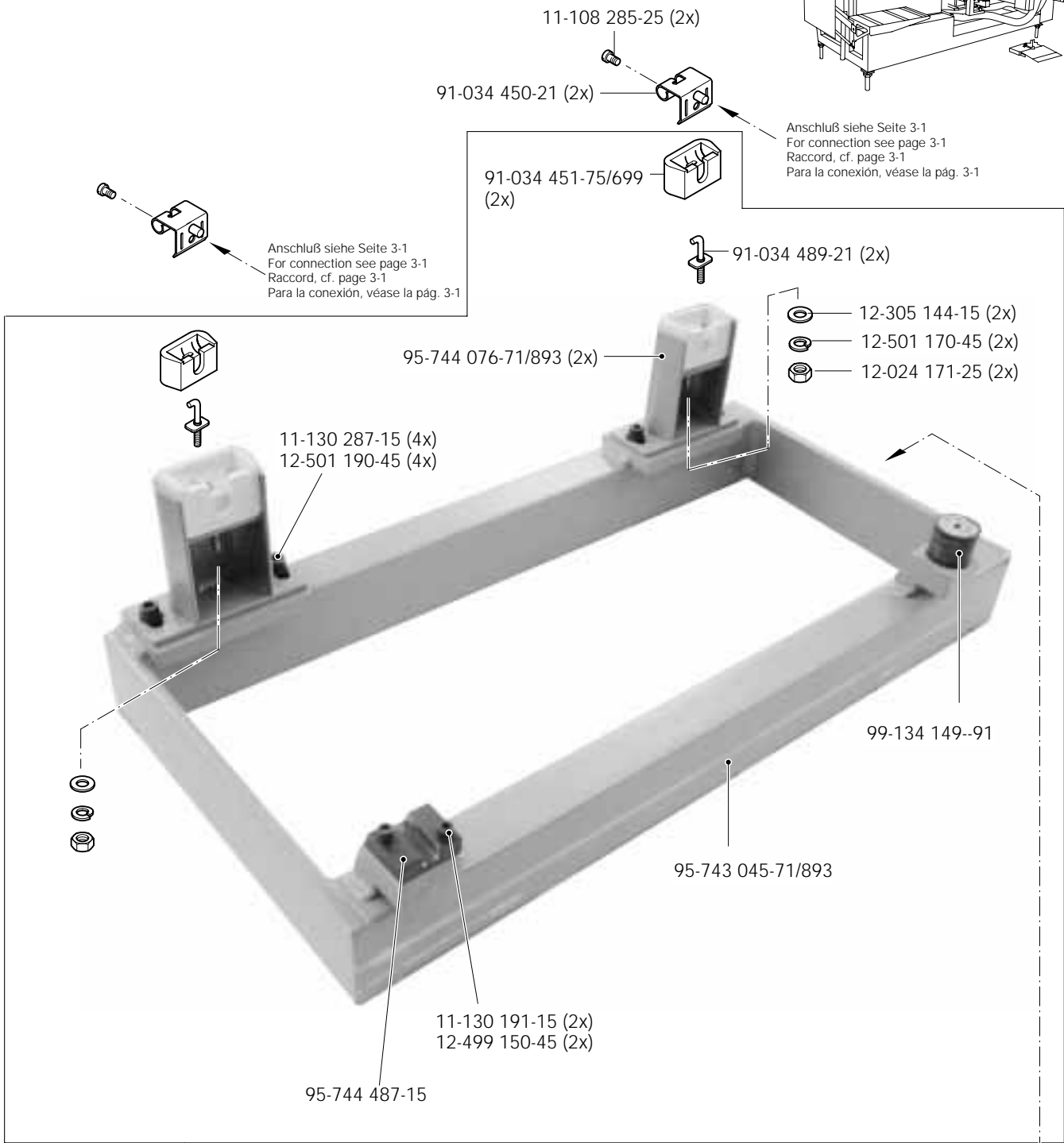
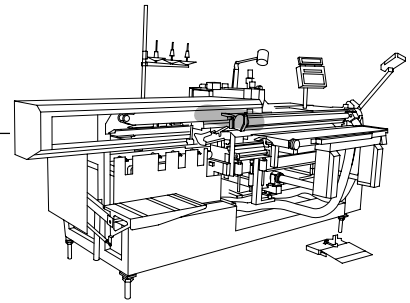

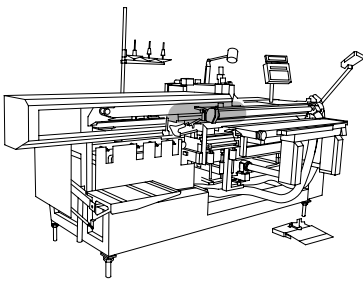

Stoffübernahme
Material take-over unit
Pince-ouvrage
Sujetatelas

PFAFF 3519-3/12

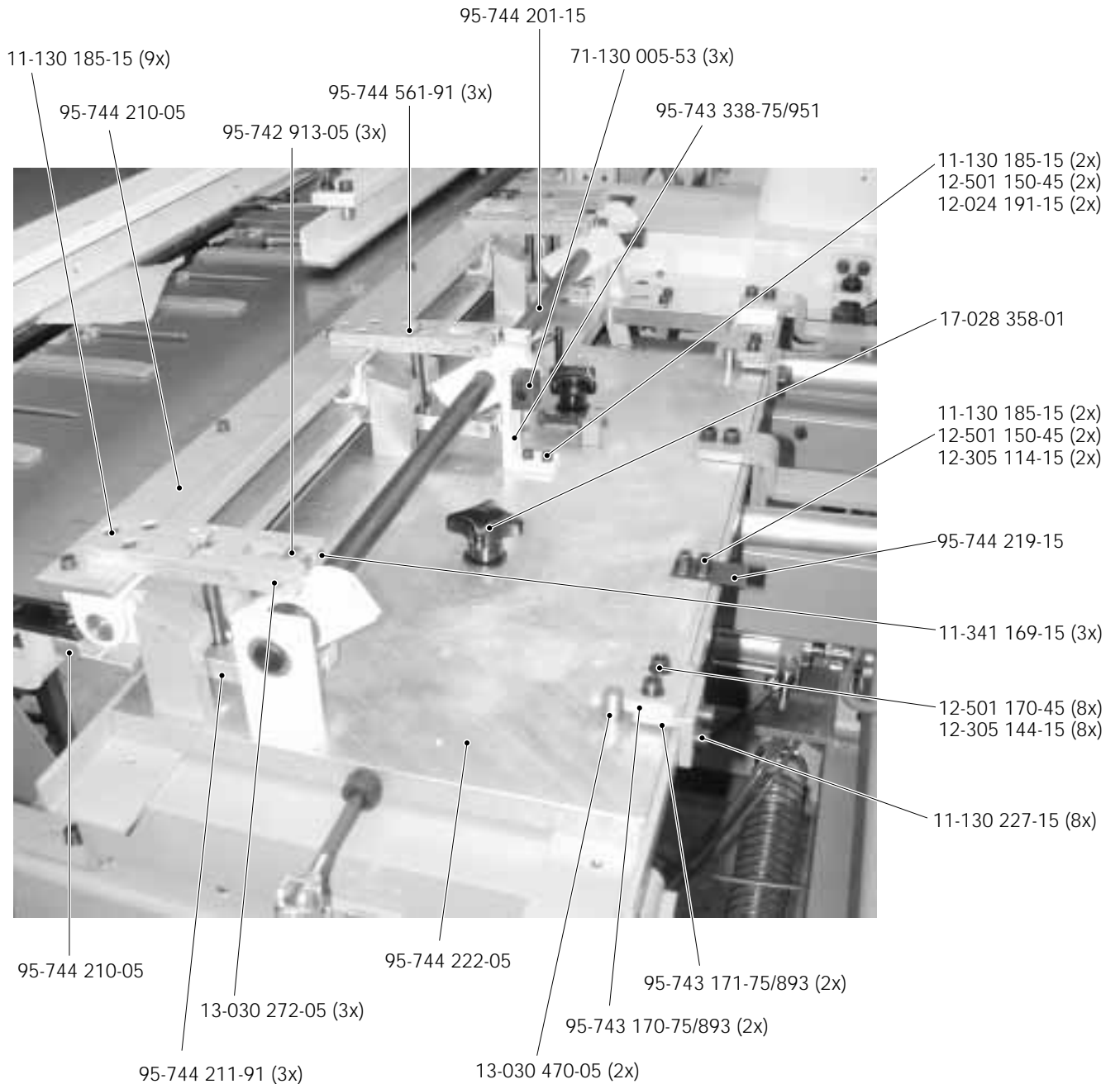

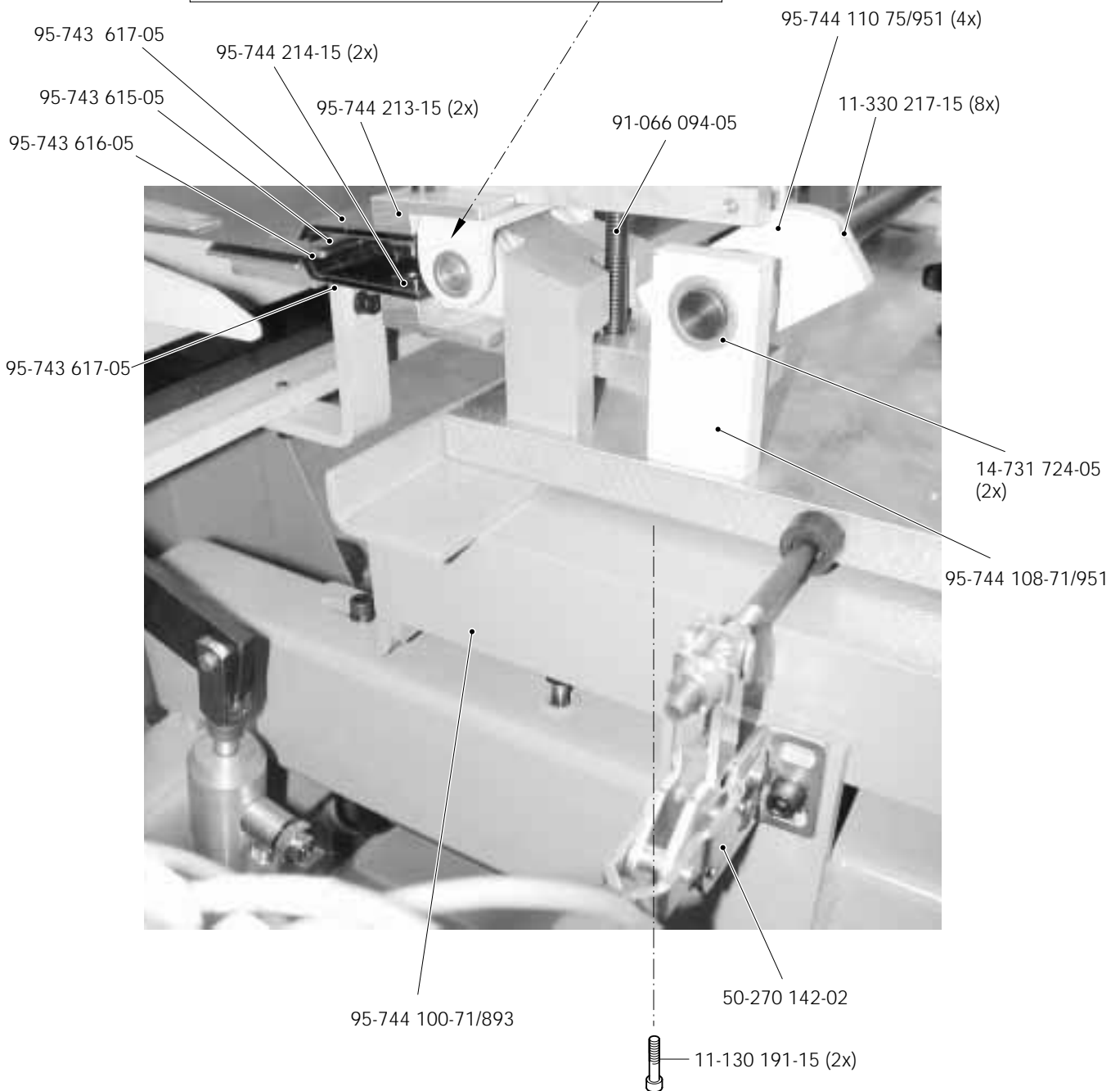
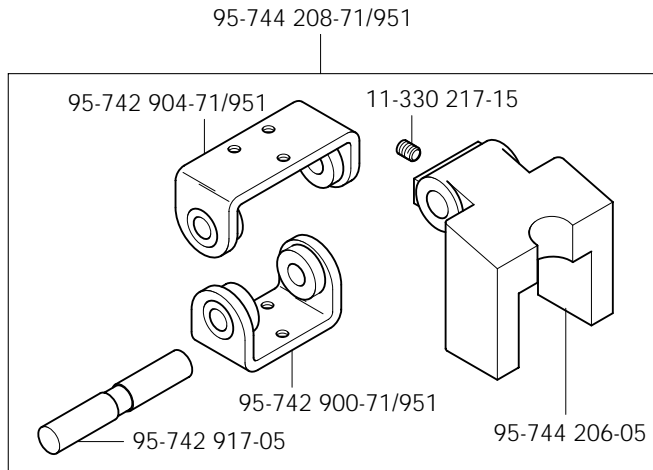
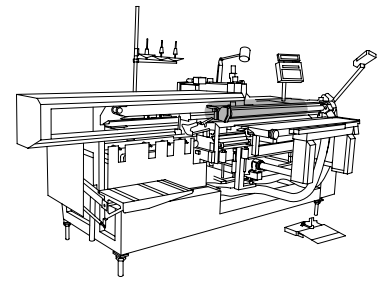

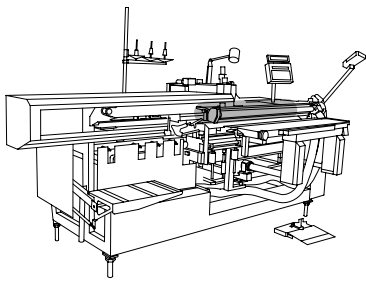

Stoffübernahme
Material take-over unit
Pince-ouvrage
Sujetatelas

PFAFF 3519-3/12



95-744 448-15

11-130 299-15 (4x)
12-501 190-45 (4x)

95-744 221-75/893 (2x)

99-135 417-91

12-024 191-15 (4x)
12-305 174-15 (4x)

99-134 520-91

99-134 850-91 (4x)

Anschluß siehe Seite 14-4
For connection see page 14-4
Raccord, cf. page 14-4
Para la conexión, véase la pág. 14-4

99-134 358-91

99-134 833-91

Anschluß siehe Seite 14-4
For connection see page 14-4
Raccord, cf. page 14-4
Para la conexión, véase la pág. 14-4

Anschluß siehe Seite 14-4
For connection see page 14-4
Raccord, cf. page 14-4
Para la conexión, véase la pág. 14-4

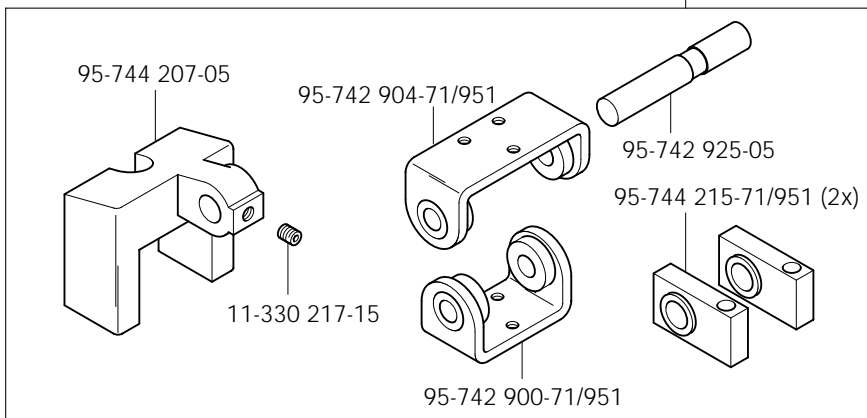
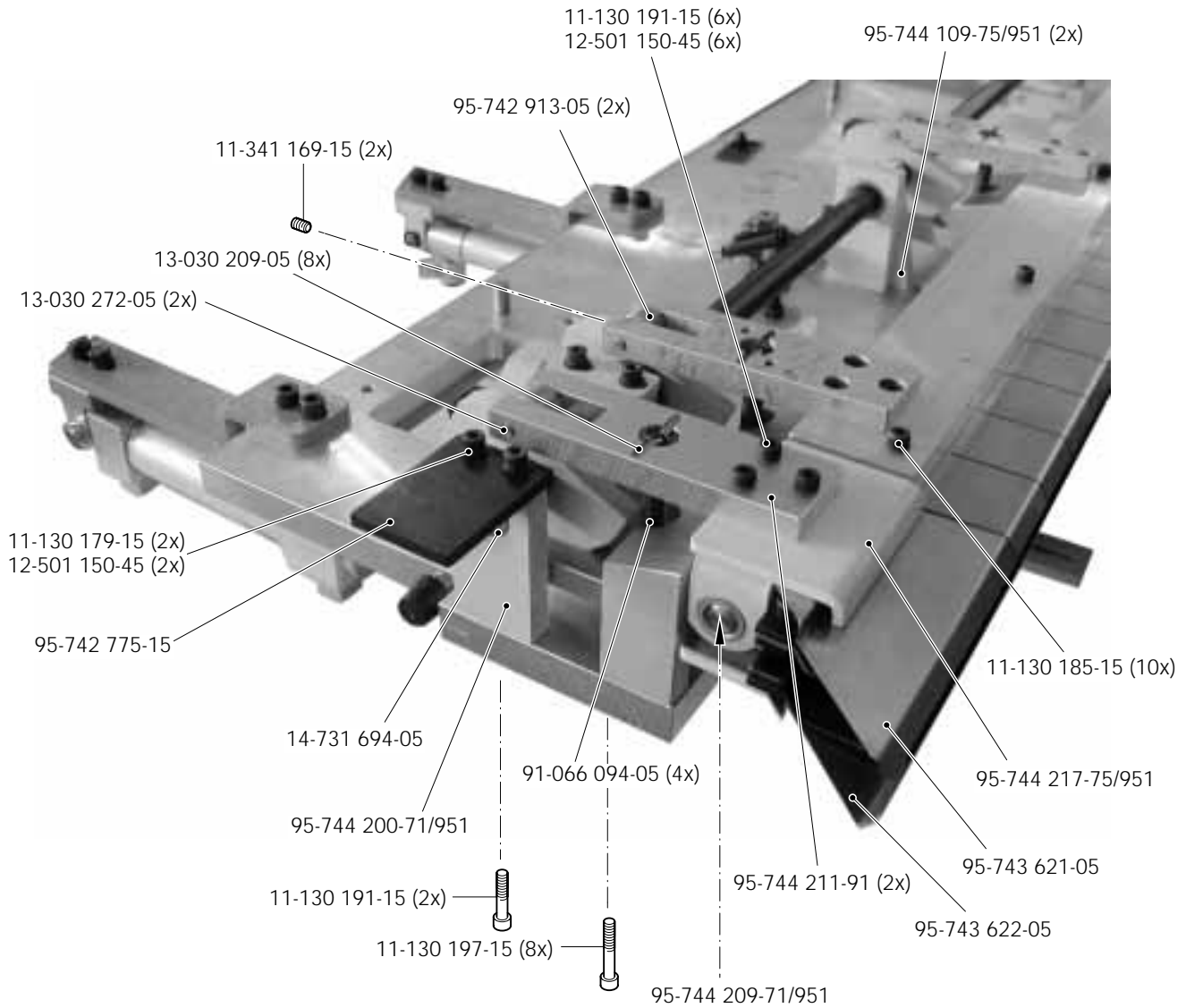
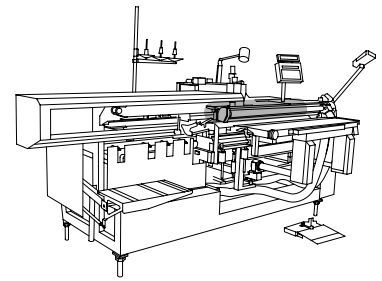

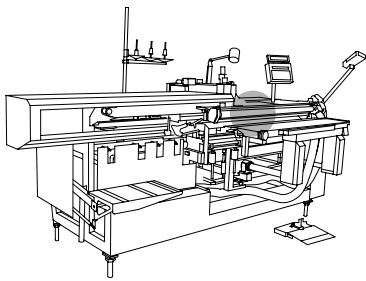

Schneidvorrichtung
Cutting device
Dispositif de coupe
Dispositivo de corte PFAFF 3519-3/12

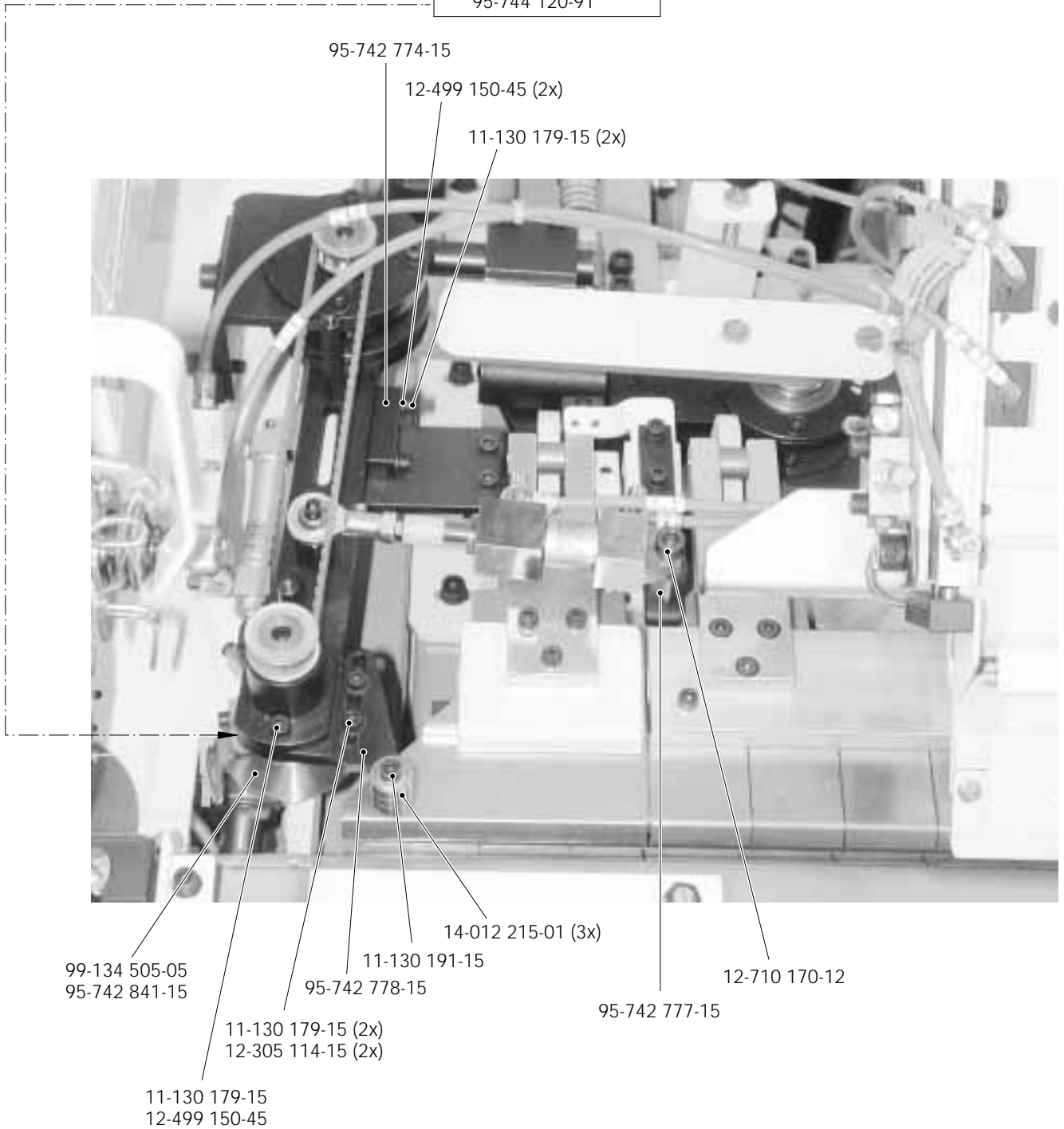
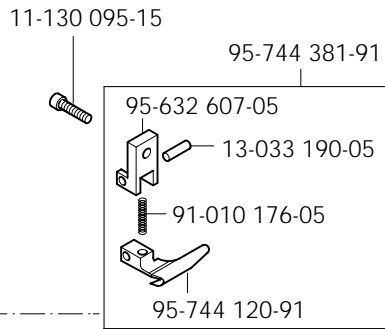

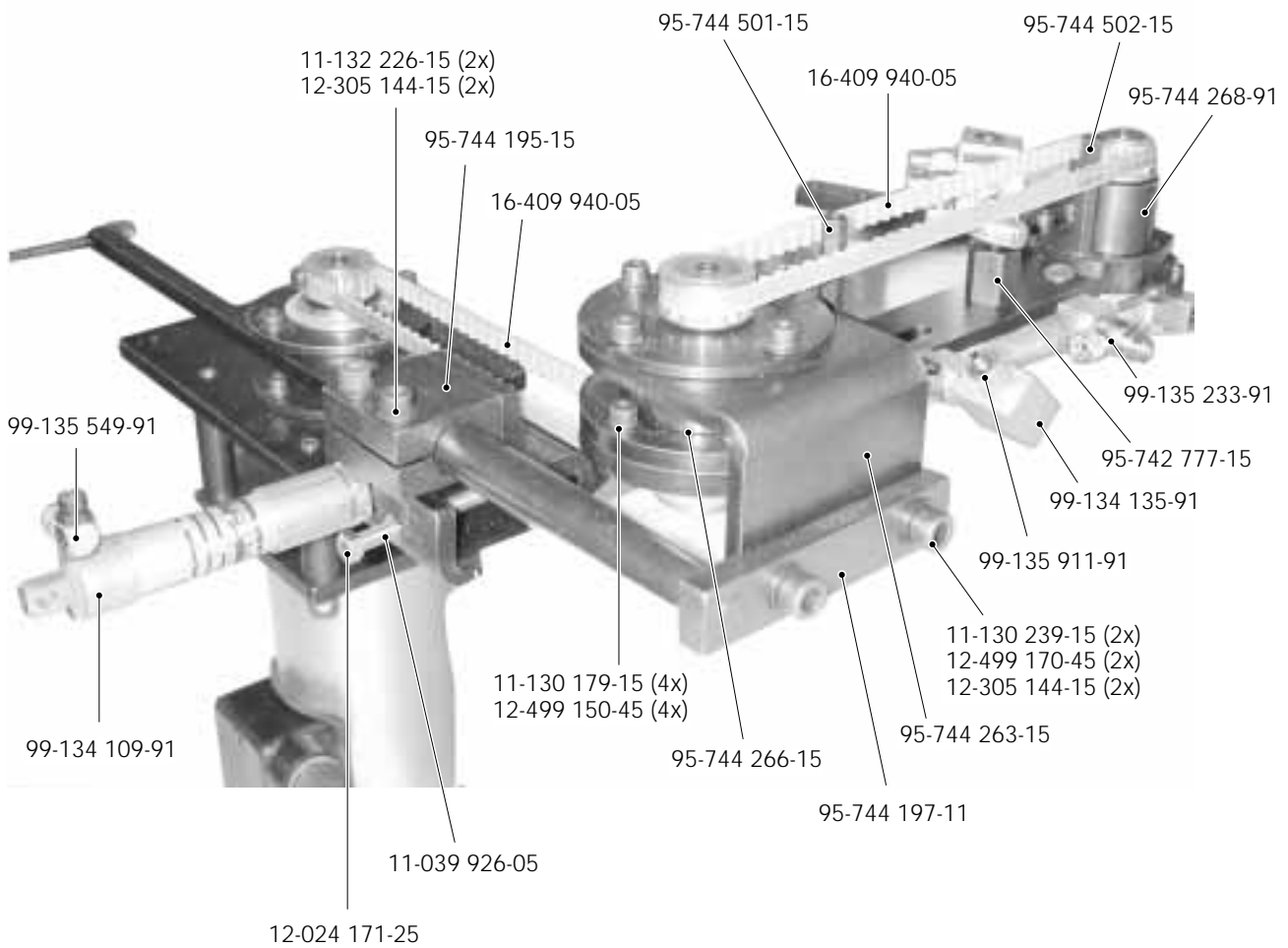
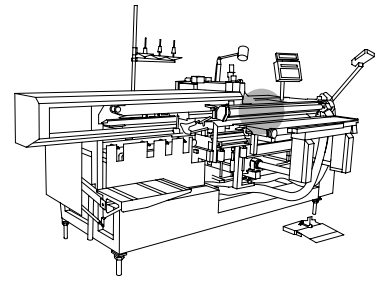

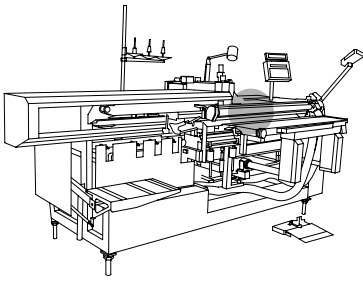

Schneidvorrichtung
 Cutting device
 Dispositif de coupe
 Dispositivo de corte PFAFF 3519-3/12

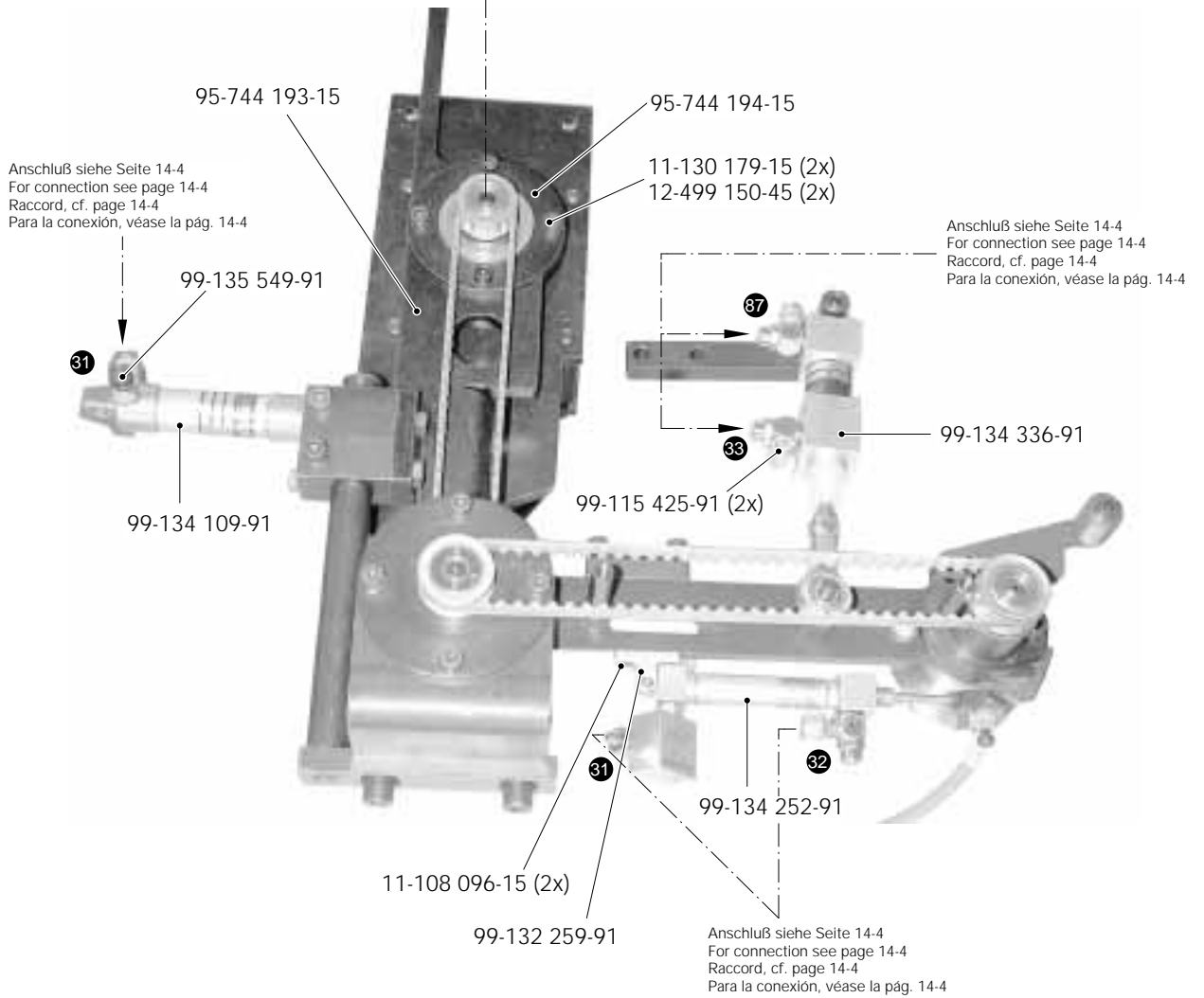
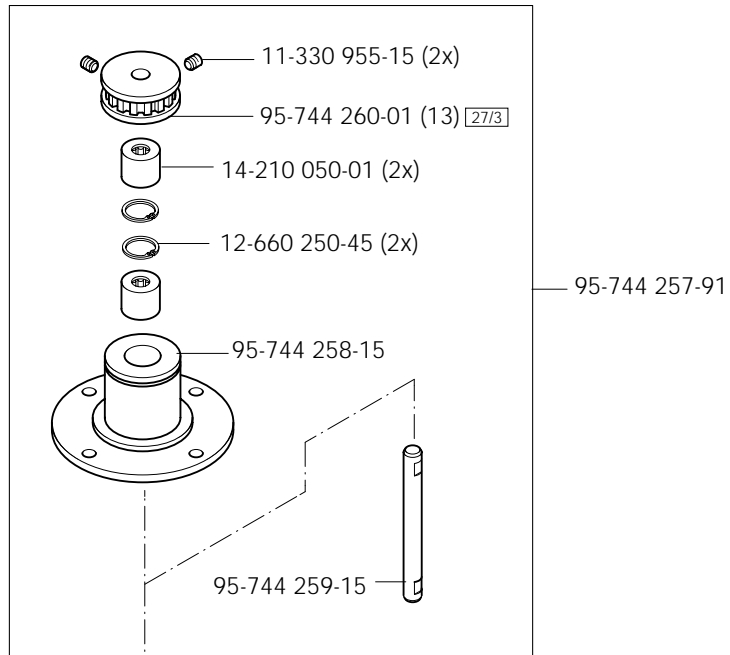

6

Schneidvorrichtung
Cutting device
Dispositif de coupe
Dispositivo de corte PFAFF 3519-3/12

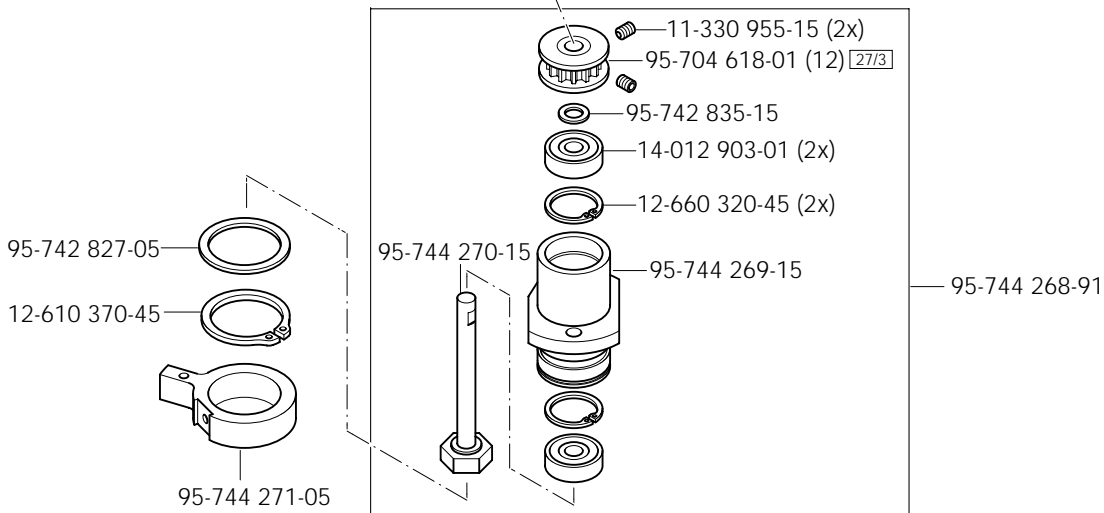
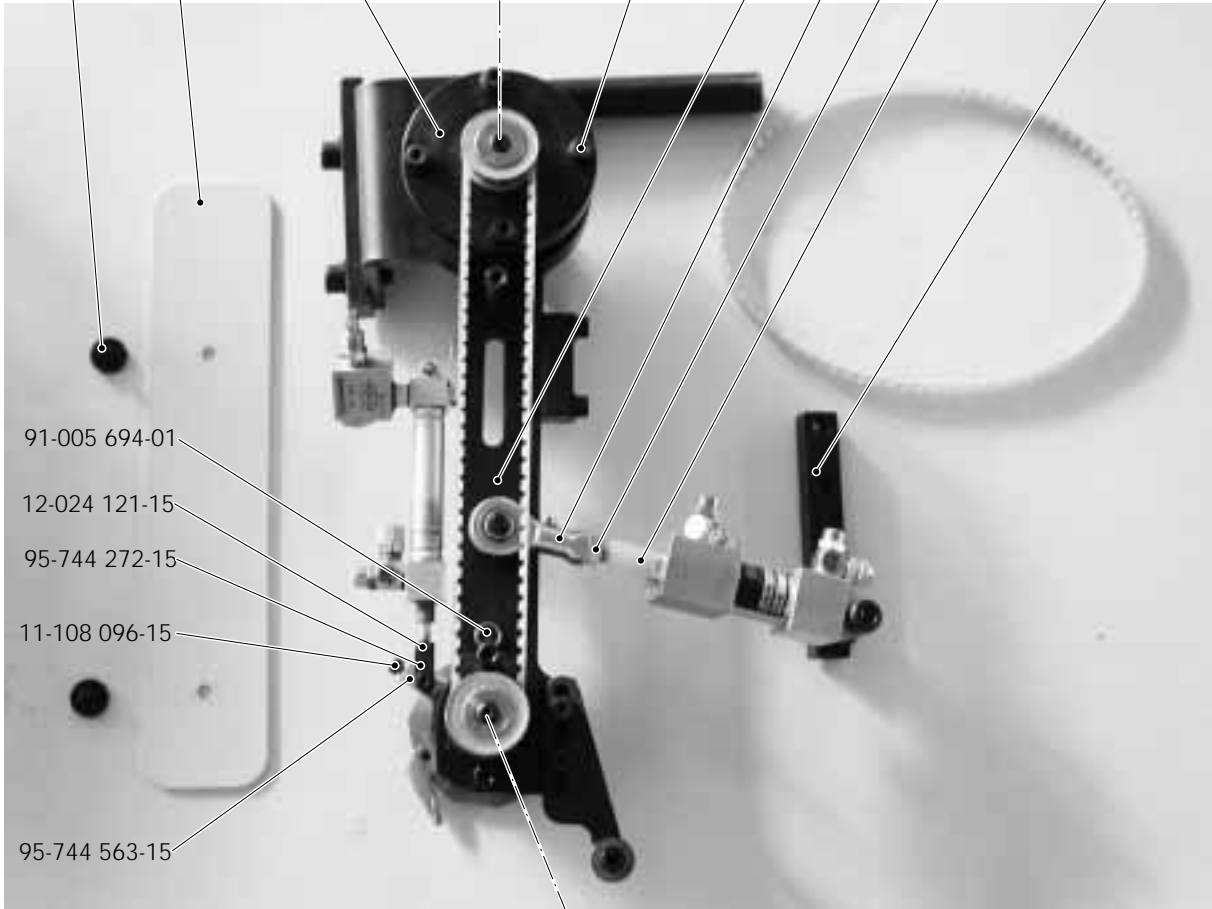
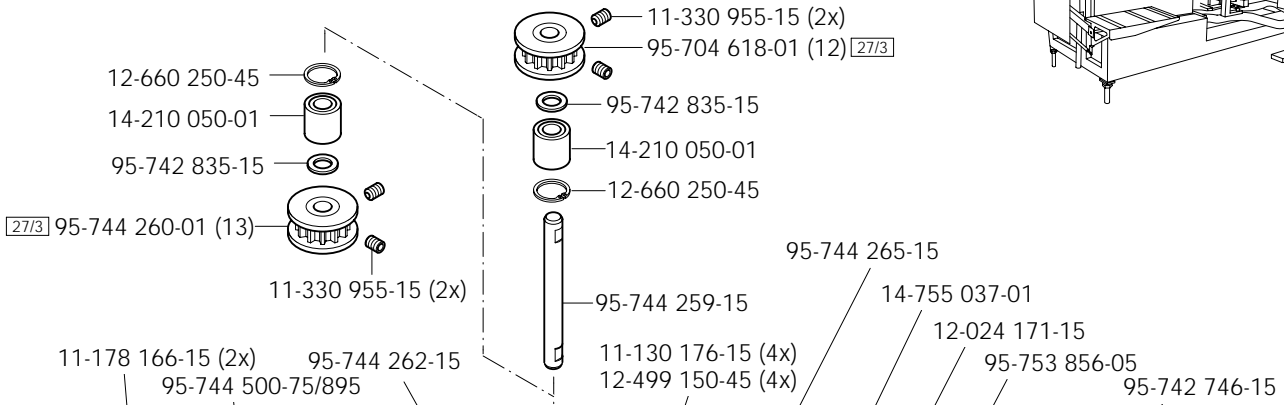
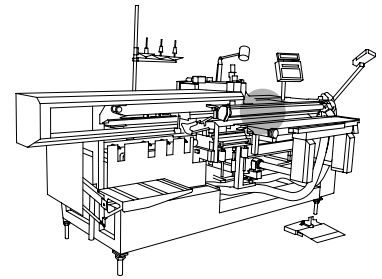

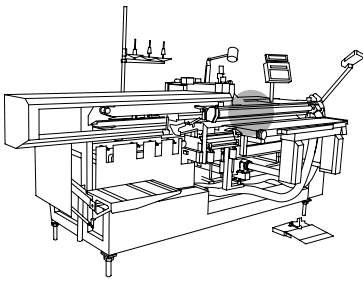

Schneidvorrichtung
 Cutting device
 Dispositif de coupe
 Dispositivo de corte PFAFF 3519-3/12

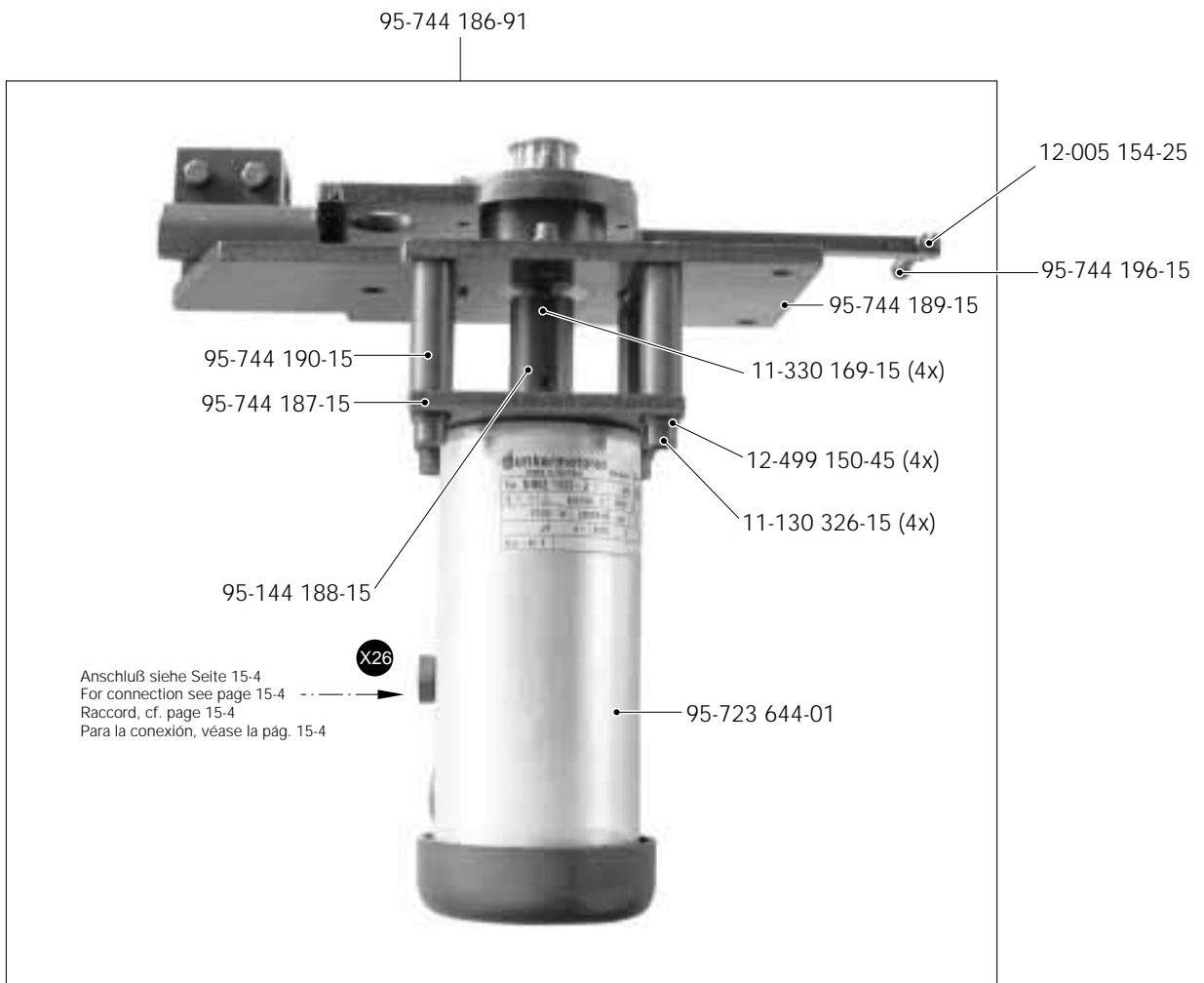

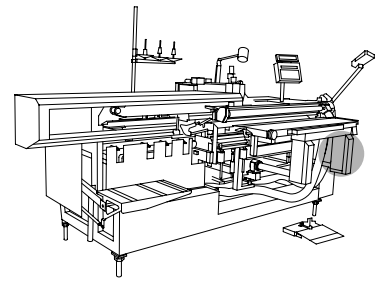

11-130 101-15 (2x)
 12-499 120-45 (2x)
 12-305 084-15 (2x)

16-041 075-11

95-743 412-15

95-742 679-05

95-744 090-71/893

10

Anschluß siehe Seite 14-3
 For connection see page 14-3
 Raccord, cf. page 14-3
 Para la conexión, véase la pág. 14-3

11

18-278 005-91 (2x)

99-136 702-91

99-135 233-91 (2x)

12-710 210-12

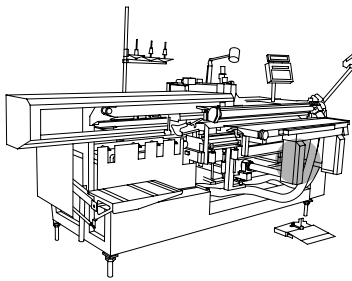

Bausatz für Zuführtisch
 Kit for infeed plate
 Kit pour table de chargement
 Juego de montaje de la mesa de alimentación PFAFF 3519-3/12

Anschluß siehe Seite 14-3
 For connection see page 14-3
 Raccord, cf. page 14-3
 Para la conexión, véase la pág. 14-3

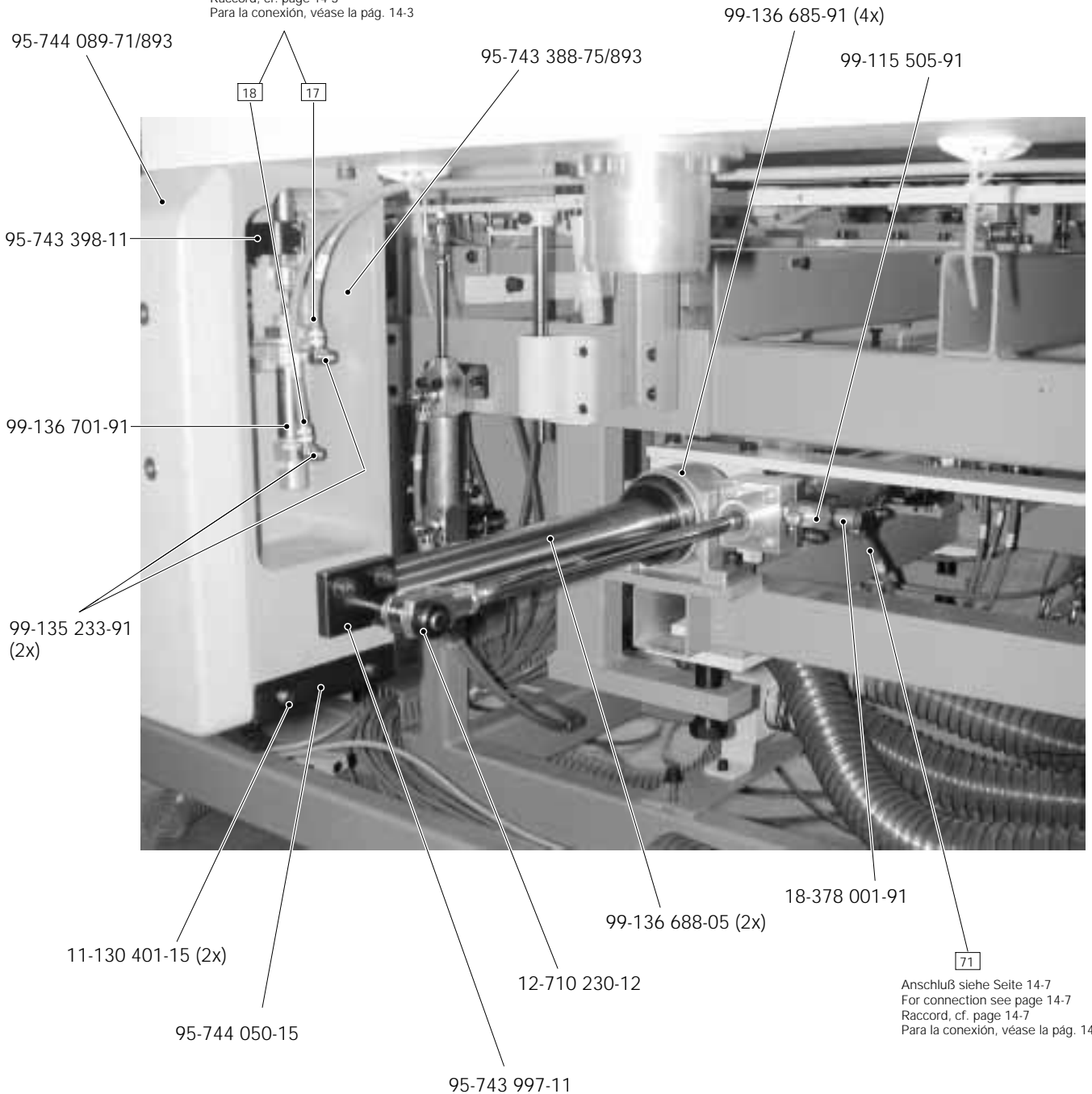

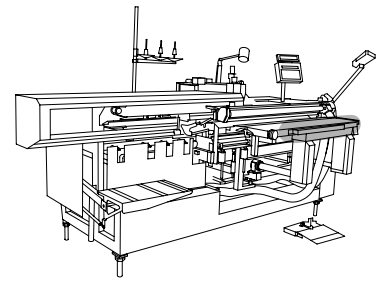

Anschluß siehe Seite 14-7
 For connection see page 14-7
 Raccord, cf. page 14-7
 Para la conexión, véase la pág. 14-7

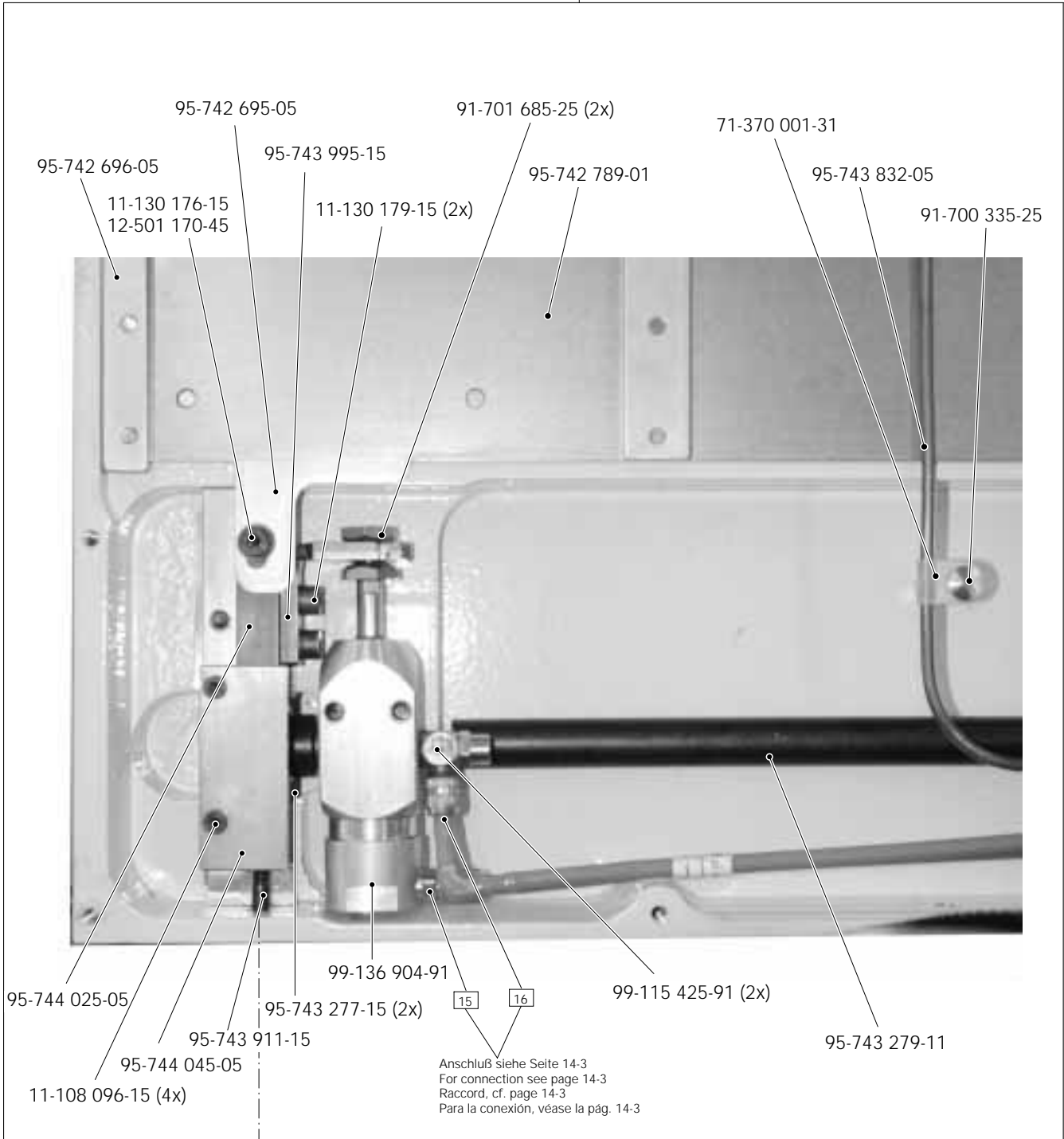

95-744 092-71/895



 11-330 349-15

 12-024 211-15

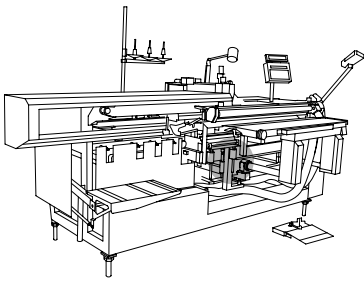

Bausatz für Zuführtisch
 Kit for infeed plate
 Kit pour table de chargement
 Juego de montaje de la mesa de alimentación PFAFF 3519-3/12



17-518 070-51 (2x) 95-744 015-91 99-134 850-91 (2x)

99-115 505-91

71-130 004-79 (2x)

18-378 001-91

72 73 74

Anschluß siehe Seite 14-7
 For connection see page 14-7
 Raccord, cf. page 14-7
 Para la conexión, véase la pág. 14-7

7

Bausatz für Zuführtisch
 Kit for infeed plate
 Kit pour table de chargement
 Juego de montaje de la mesa de alimentación PFAFF 3519-3/12

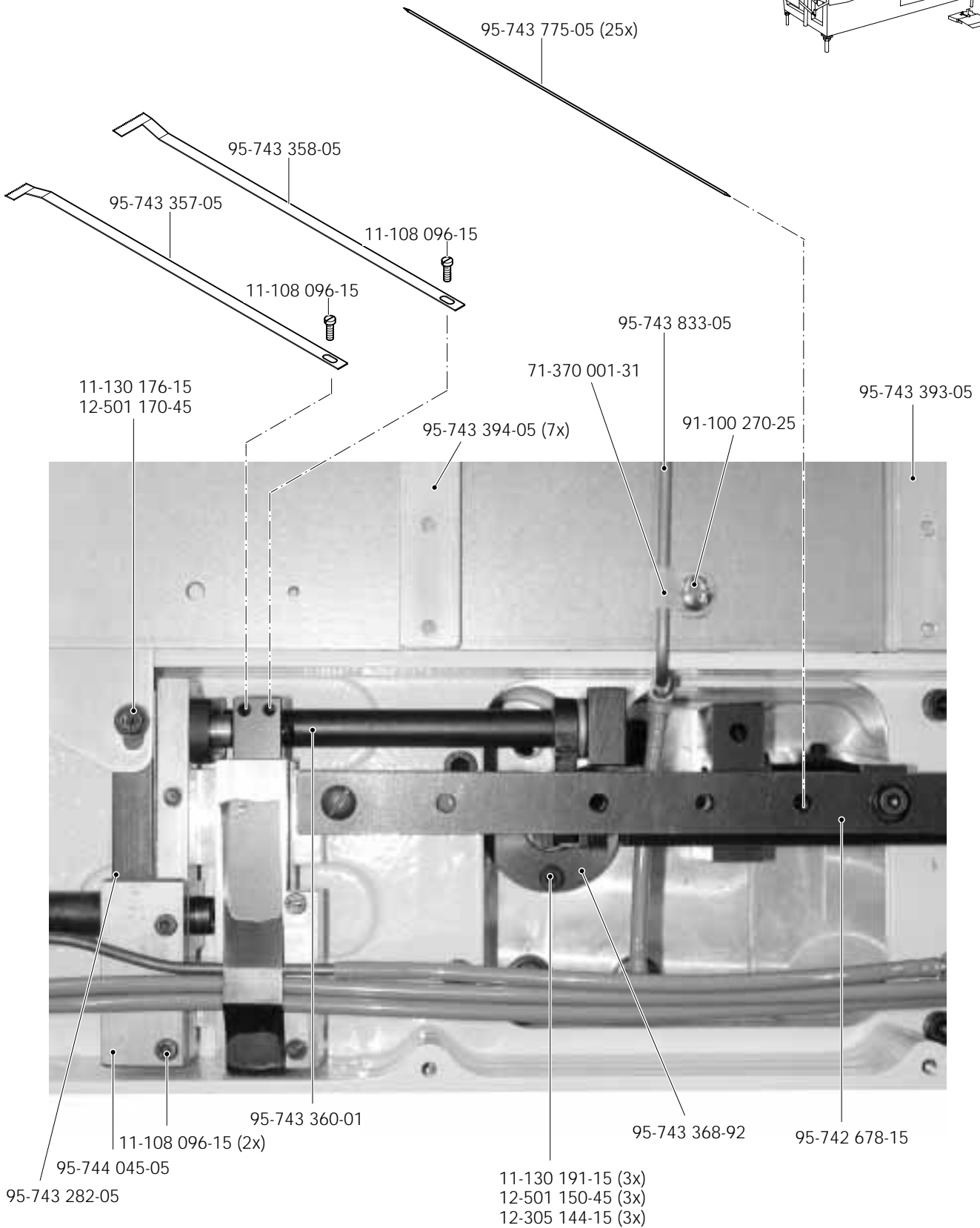
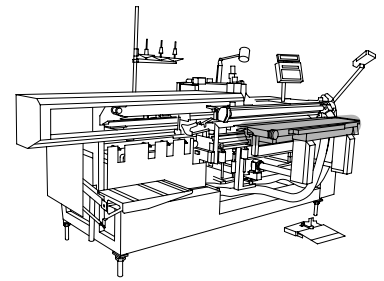

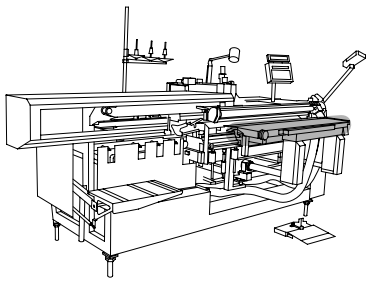

Bausatz für Zuführtisch
 Kit for infeed plate
 Kit pour table de chargement
 Juego de montaje de la mesa de alimentación PFAFF 3519-3/12

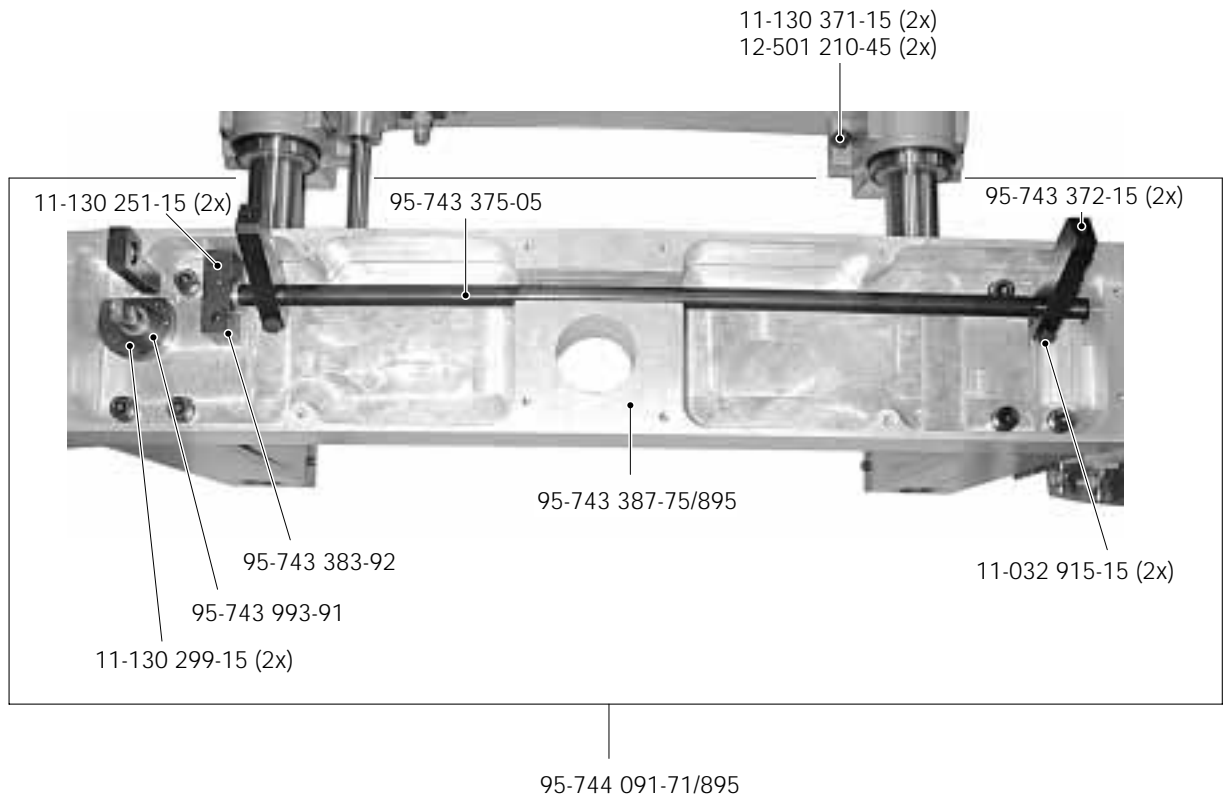

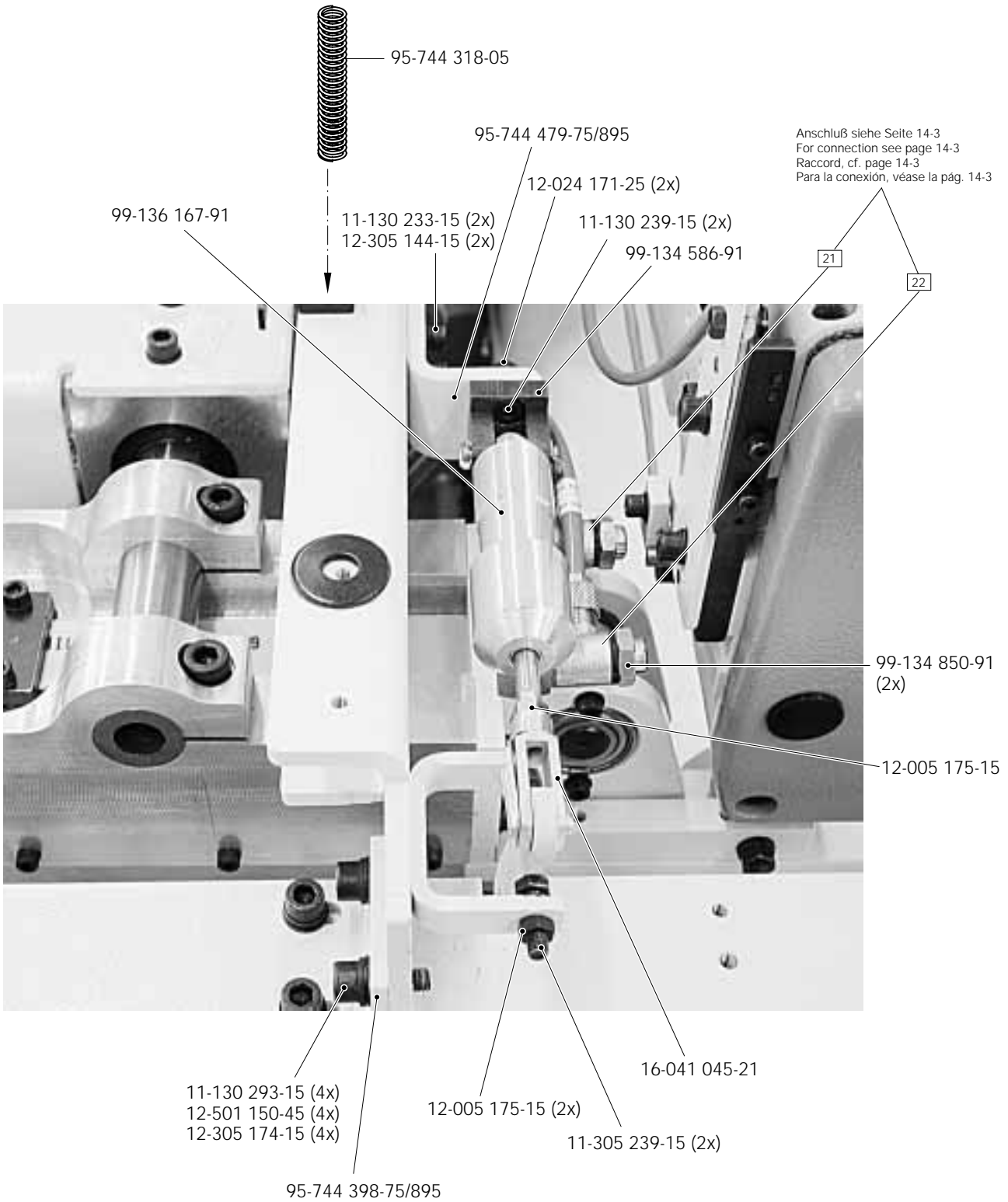
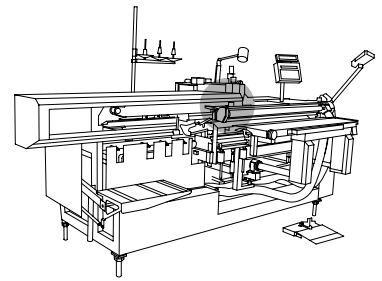

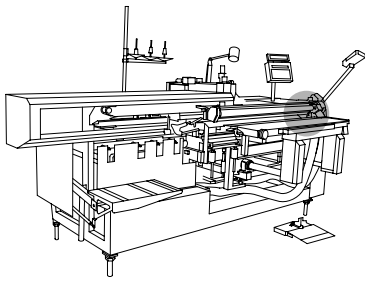

Abstreifvorrichtung
Wiping device
Racleur de fil
Deflector

PFAFF 3519-3/12

95-743 252-15

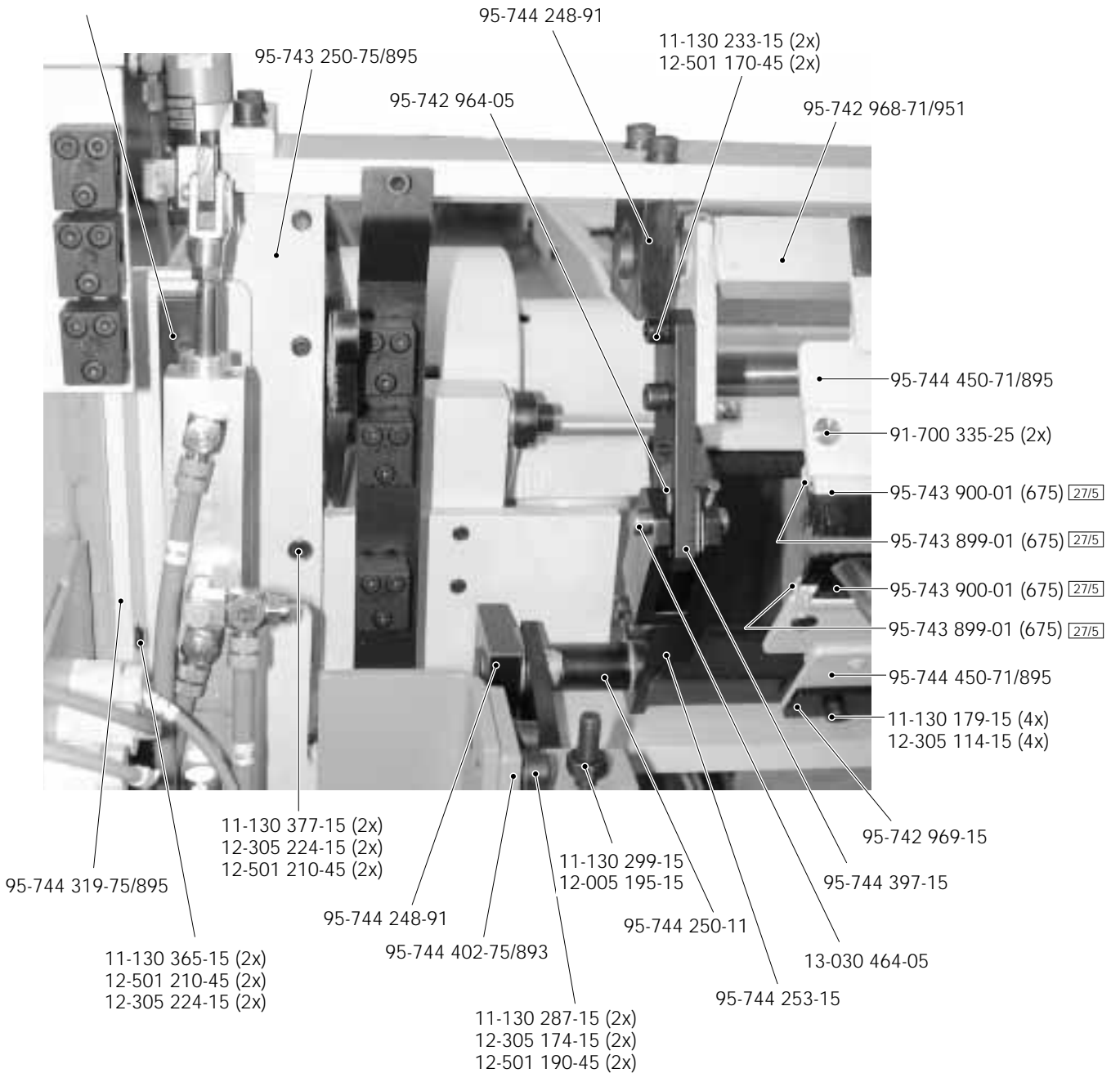

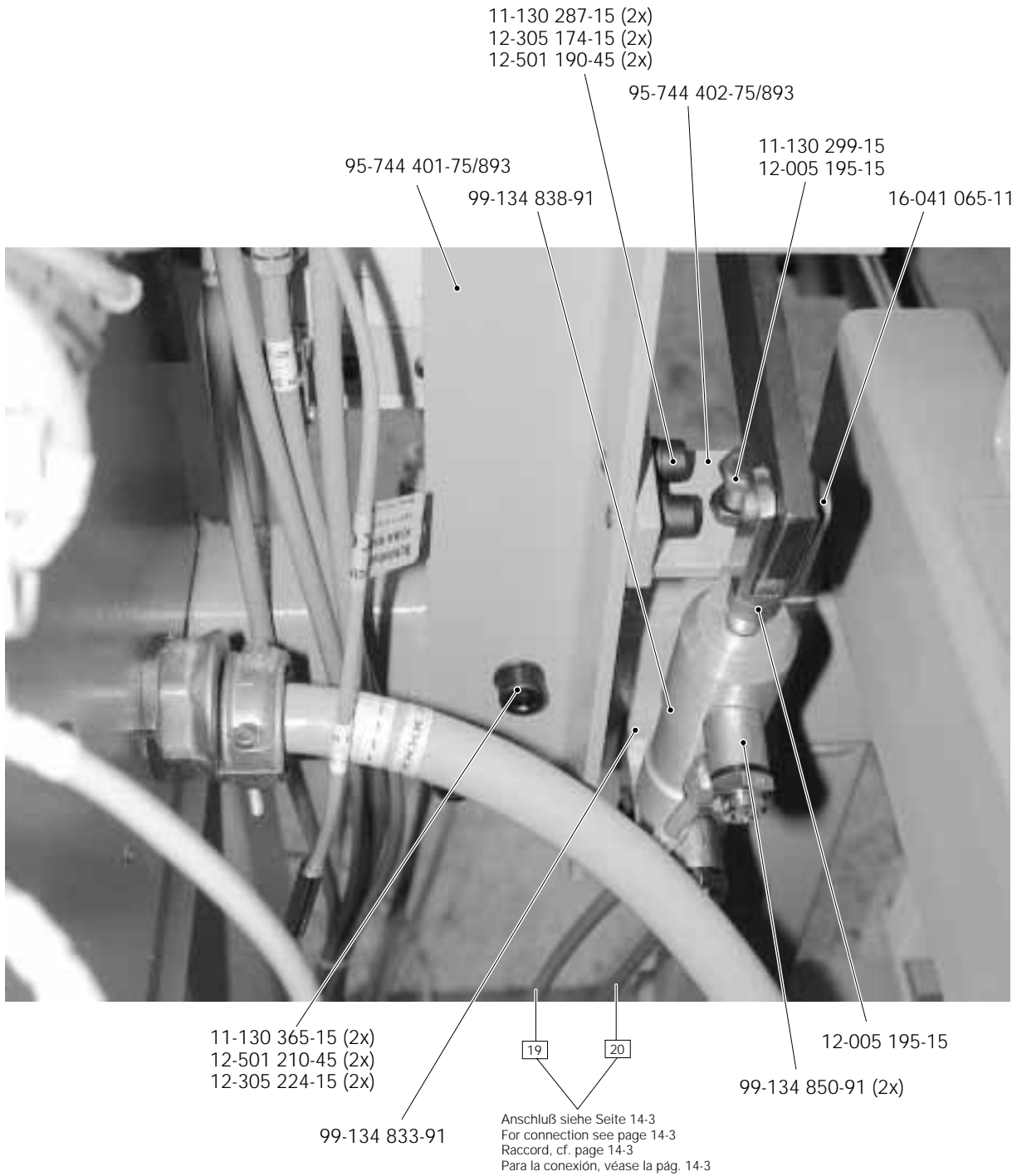
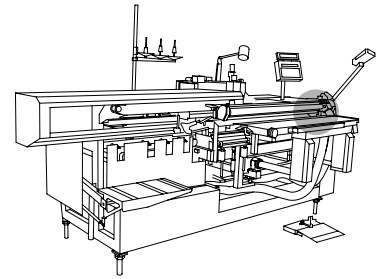

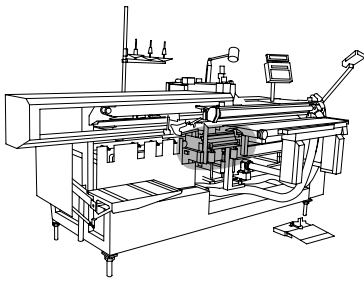

Abstreifvorrichtung
Wiping device
Racleur de fil
Deflector

PFAFF 3519-3/12

Anschluß siehe Seite 14-3
For connection see page 14-3
Raccord, cf. page 14-3
Para la conexión, véase la pág. 14-3

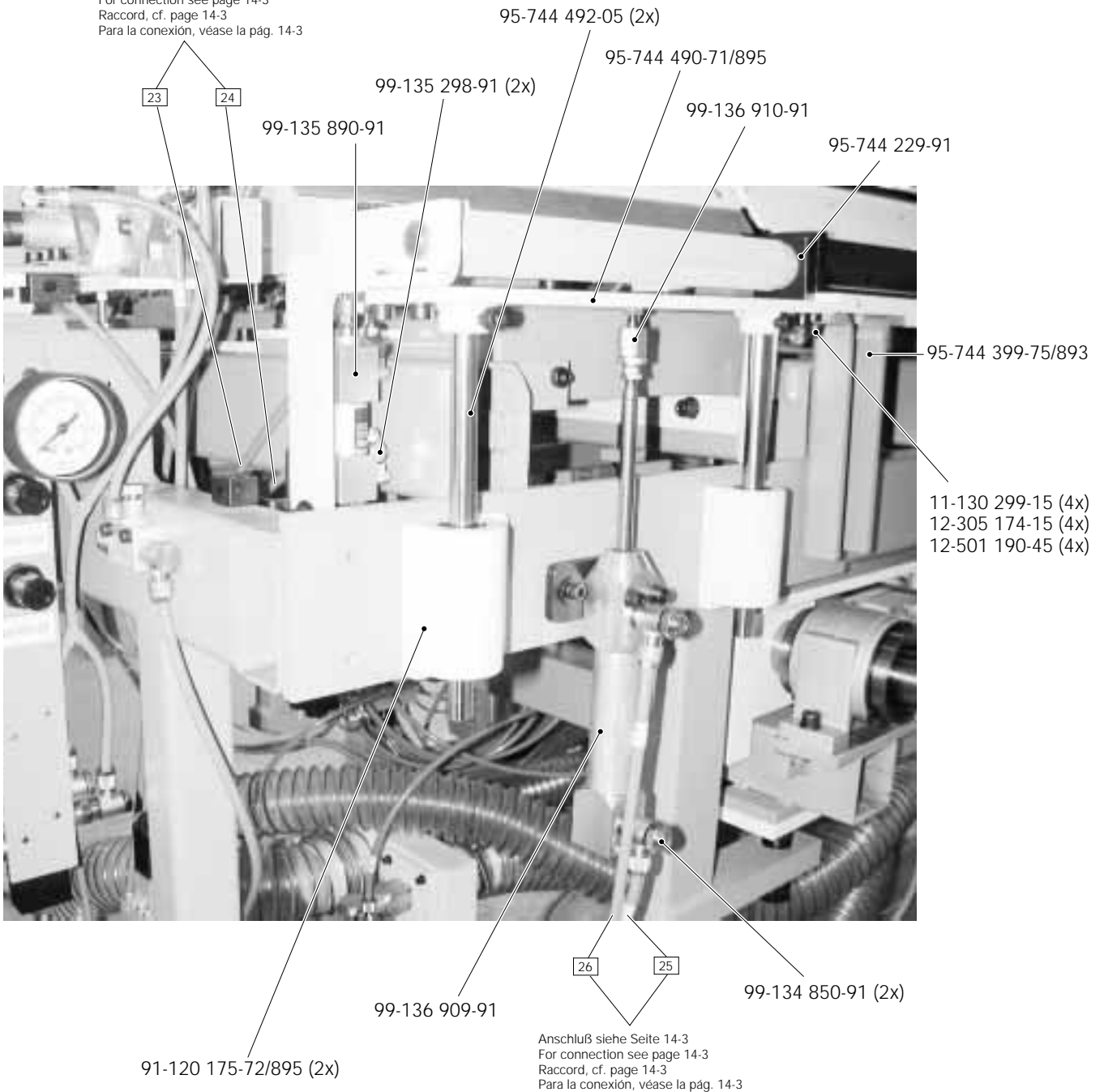

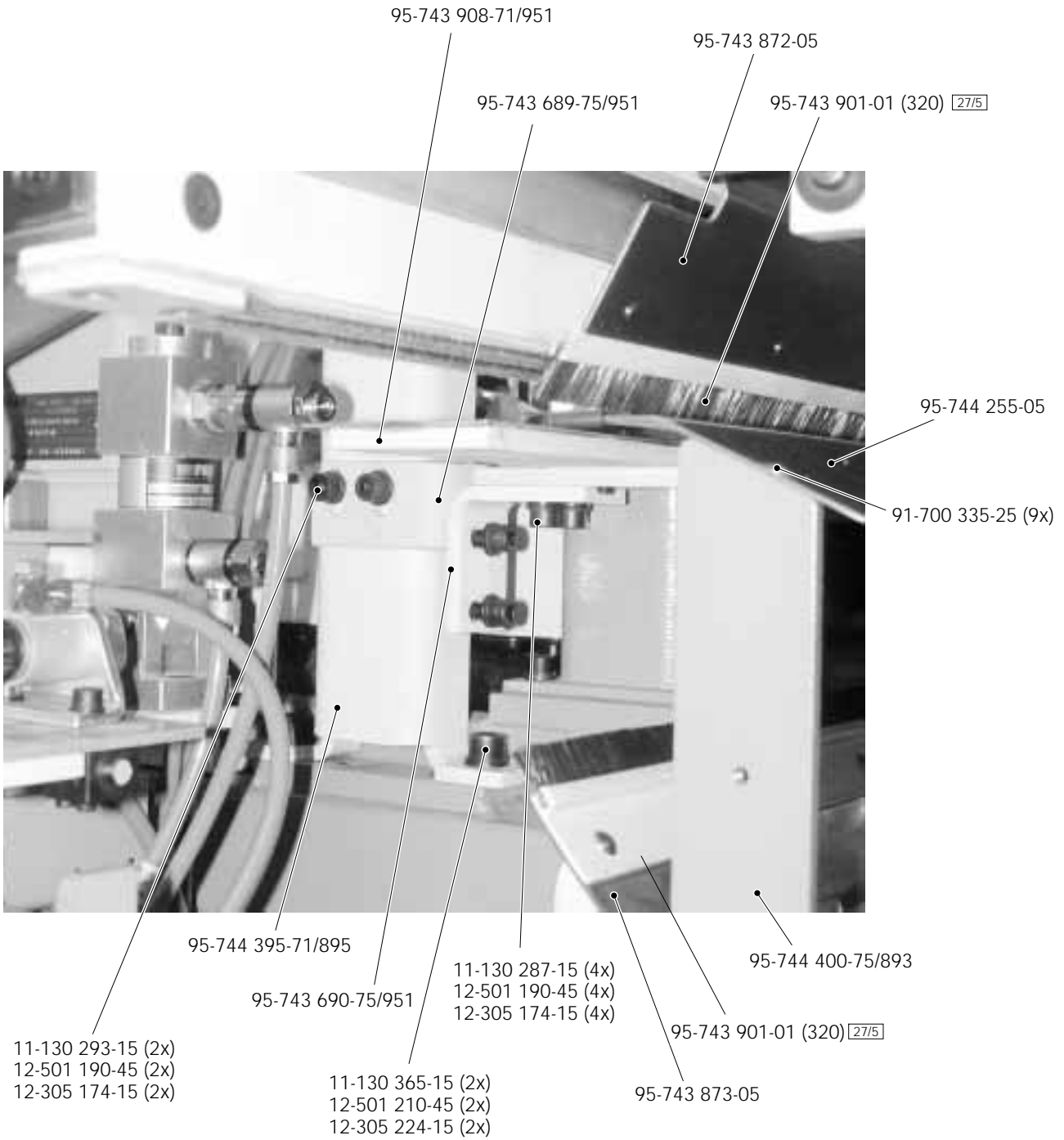
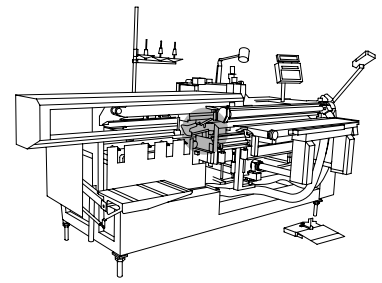

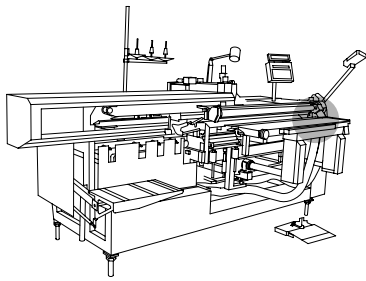

Positioniereinrichtung
 Positioning device
 Dispositif positionneur
 Dispositivo posicionador PFAFF 3519-3/12

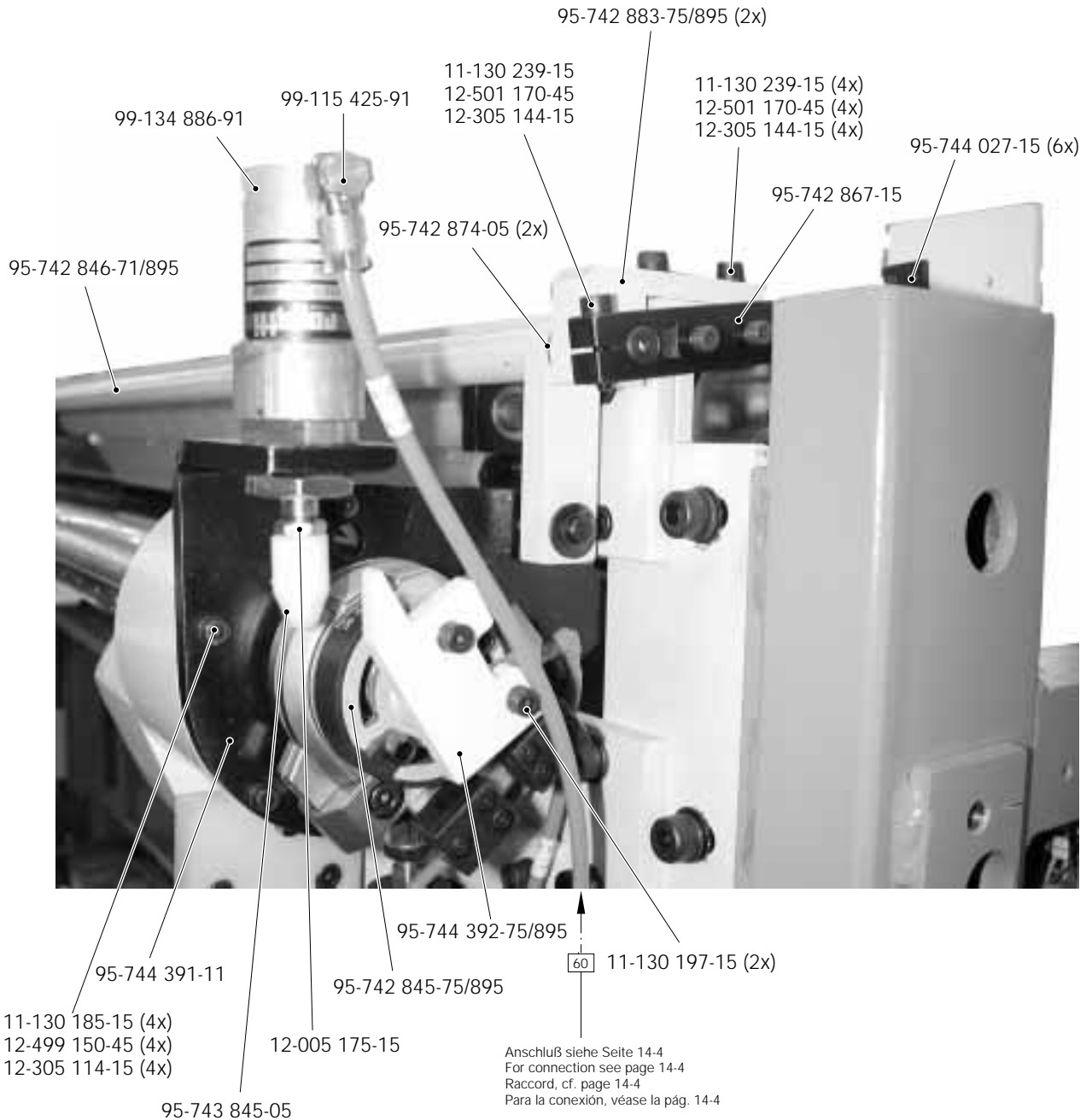

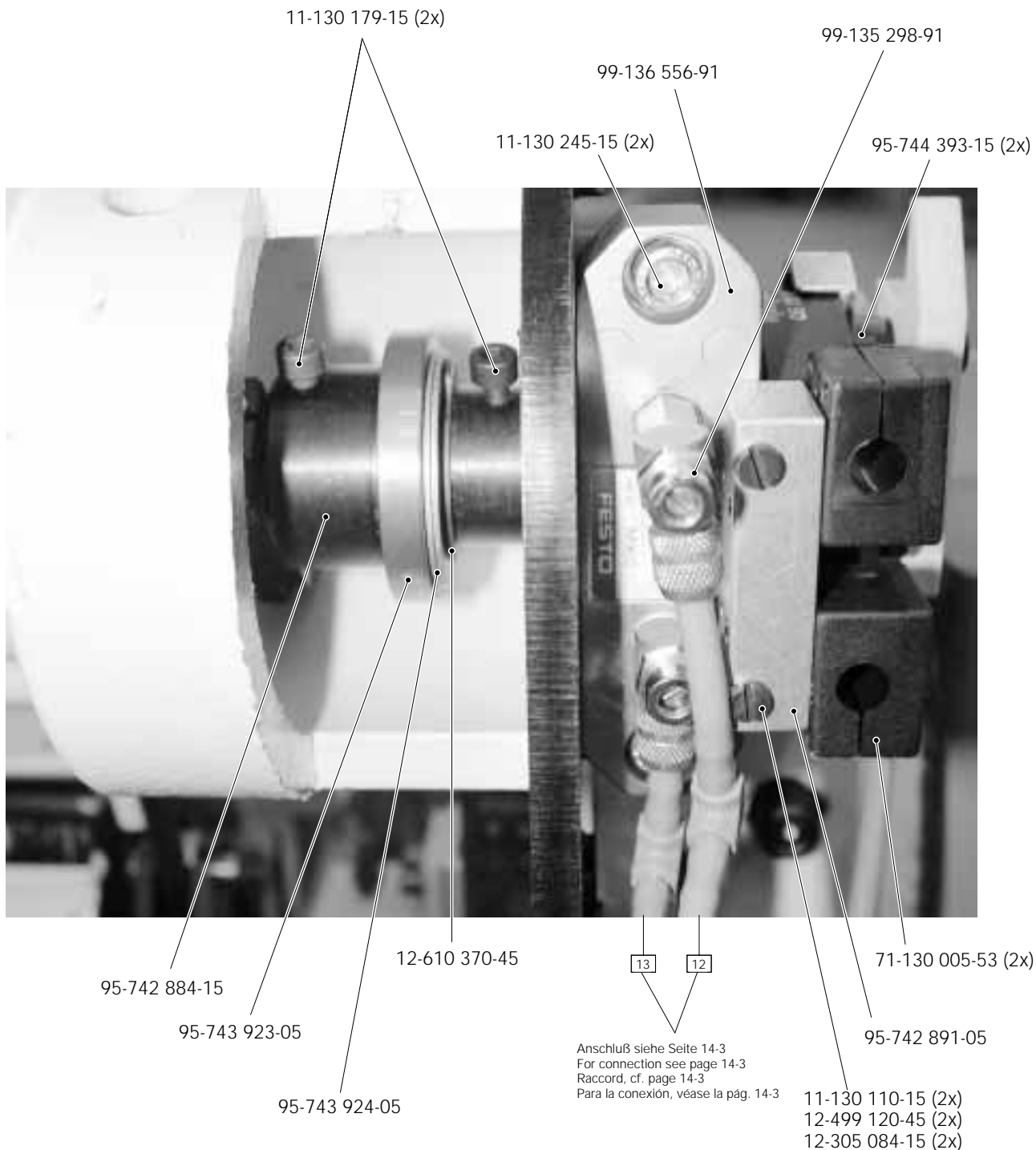
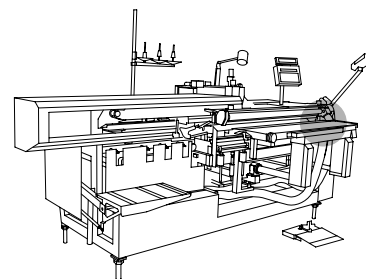

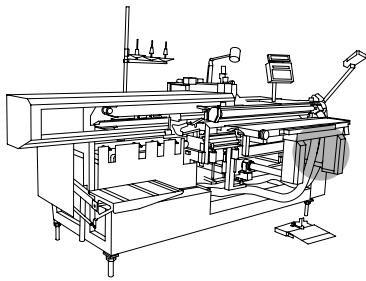

Positioniereinrichtung
 Positioning device
 Dispositif positionneur
 Dispositivo posicionador PFAFF 3519-3/12



- 99-136 661-91
 - 16-041 075-11
 - 12-024 211-15
 - 99-134 851-91 (2x)
 - 6
 - 7
 - 99-134 520-91
 - 99-115 505-91 (2x)
- Anschluß siehe Seite 14-4
 For connection see page 14-4
 Raccord, cf. page 14-4
 Para la conexión, véase la pág. 14-4

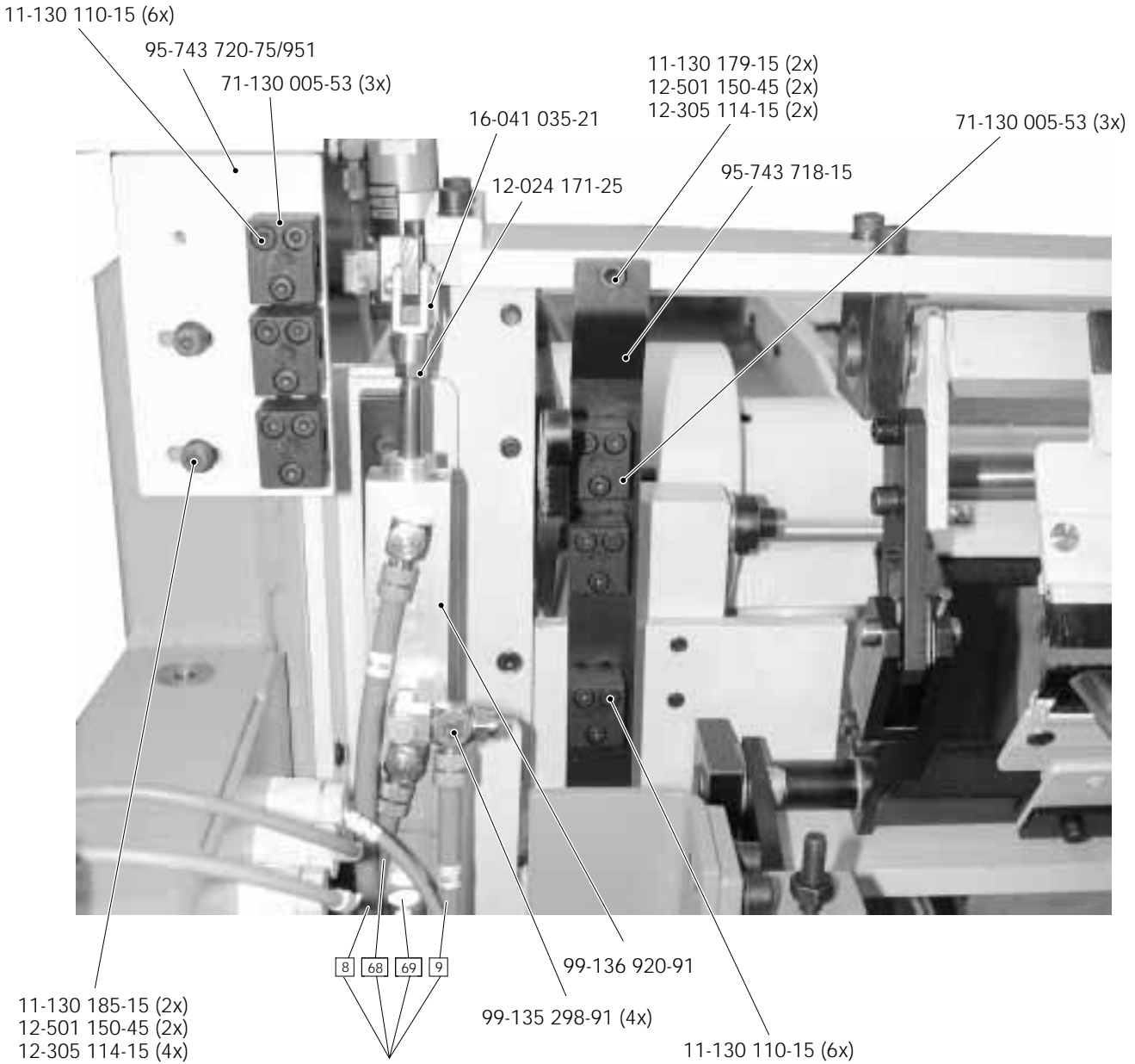
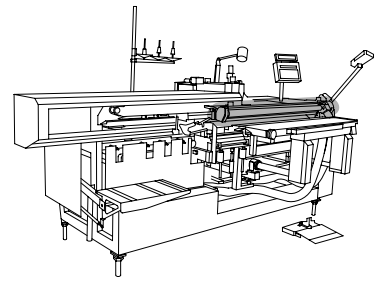

Anschluß siehe Seite 14-4
 For connection see page 14-4
 Raccord, cf. page 14-4
 Para la conexión, véase la pág. 14-4

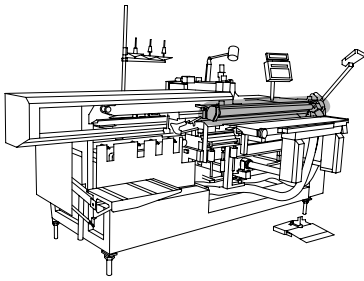

Positioniereinrichtung
 Positioning device
 Dispositif positionneur
 Dispositivo posicionador PFAFF 3519-3/12



95-744 562-91 (12x)

91-100 270-25 (13x)

11-130 185-15 (4x)
 12-499 150-45 (4x)
 12-305 114-15 (4x)

95-742 787-91

95-743 905-03/005 (x=10 mm)
 95-743 905-03/006 (x=11 mm)
 95-743 905-03/007 (x=12 mm)



95-742 690-11

95-742 692-05

95-742 694-05

95-744 093-01

95-743 672-75/895



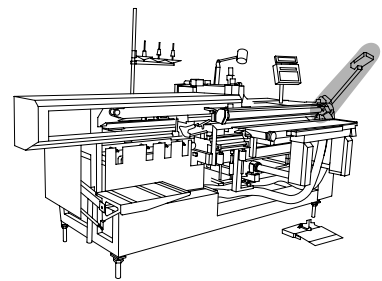

95-744 454-70/893

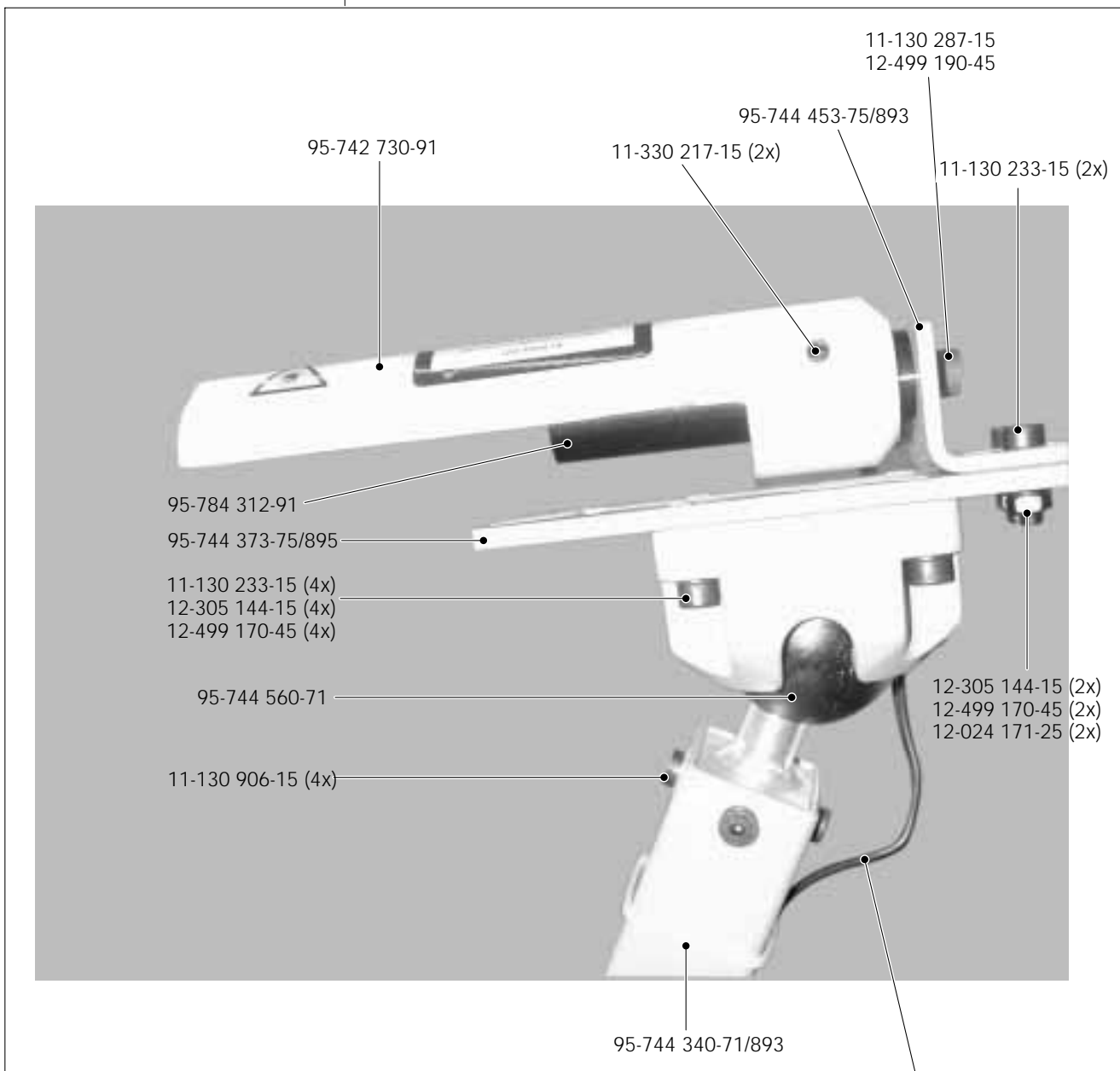

X30

Anschluß siehe Seite 15-3
For connection see page 15-3
Raccord, cf. page 15-3
Para la conexión, véase la pág.15-3

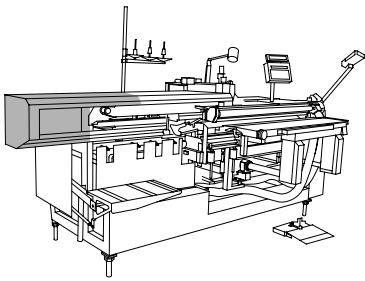

X-Y-Antrieb
 X-Y drive
 Système de commande X-Y
 Grupo de accionamiento "X-Y" PFAFF 3519-3/12

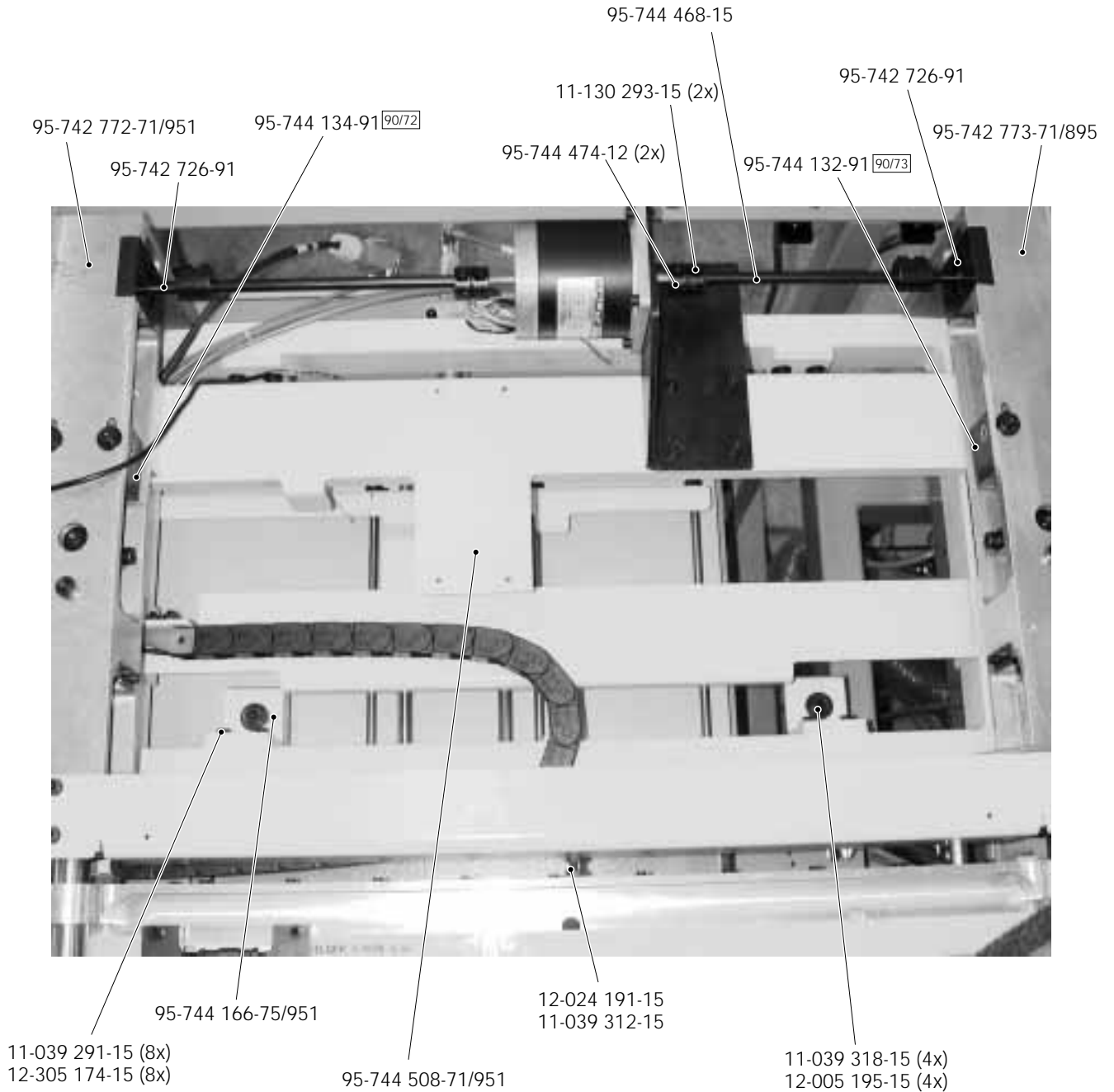

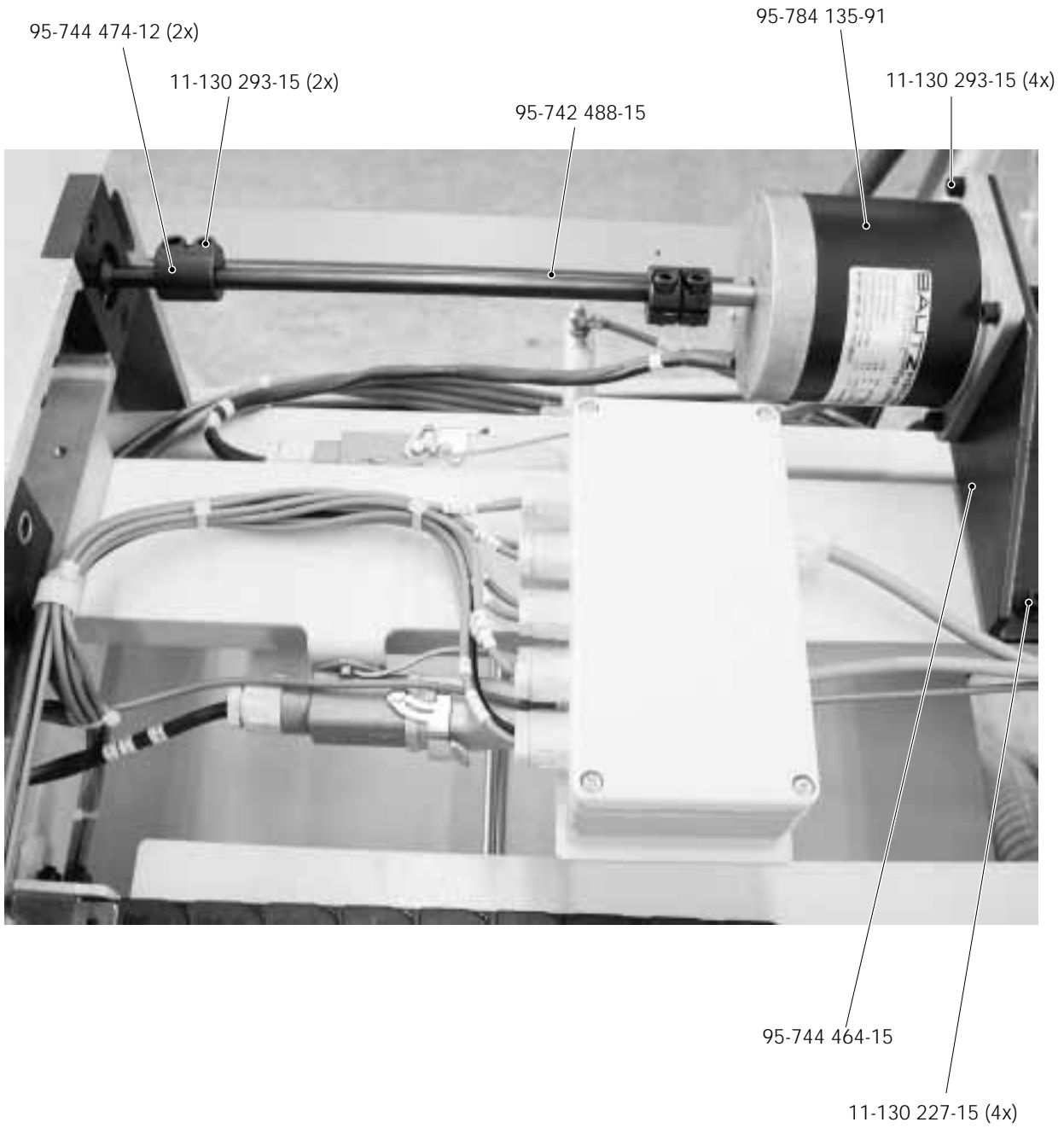
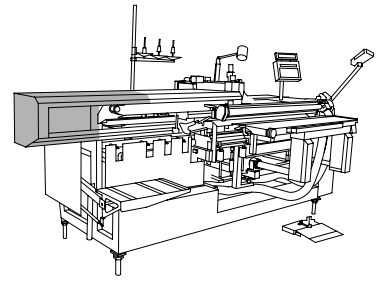

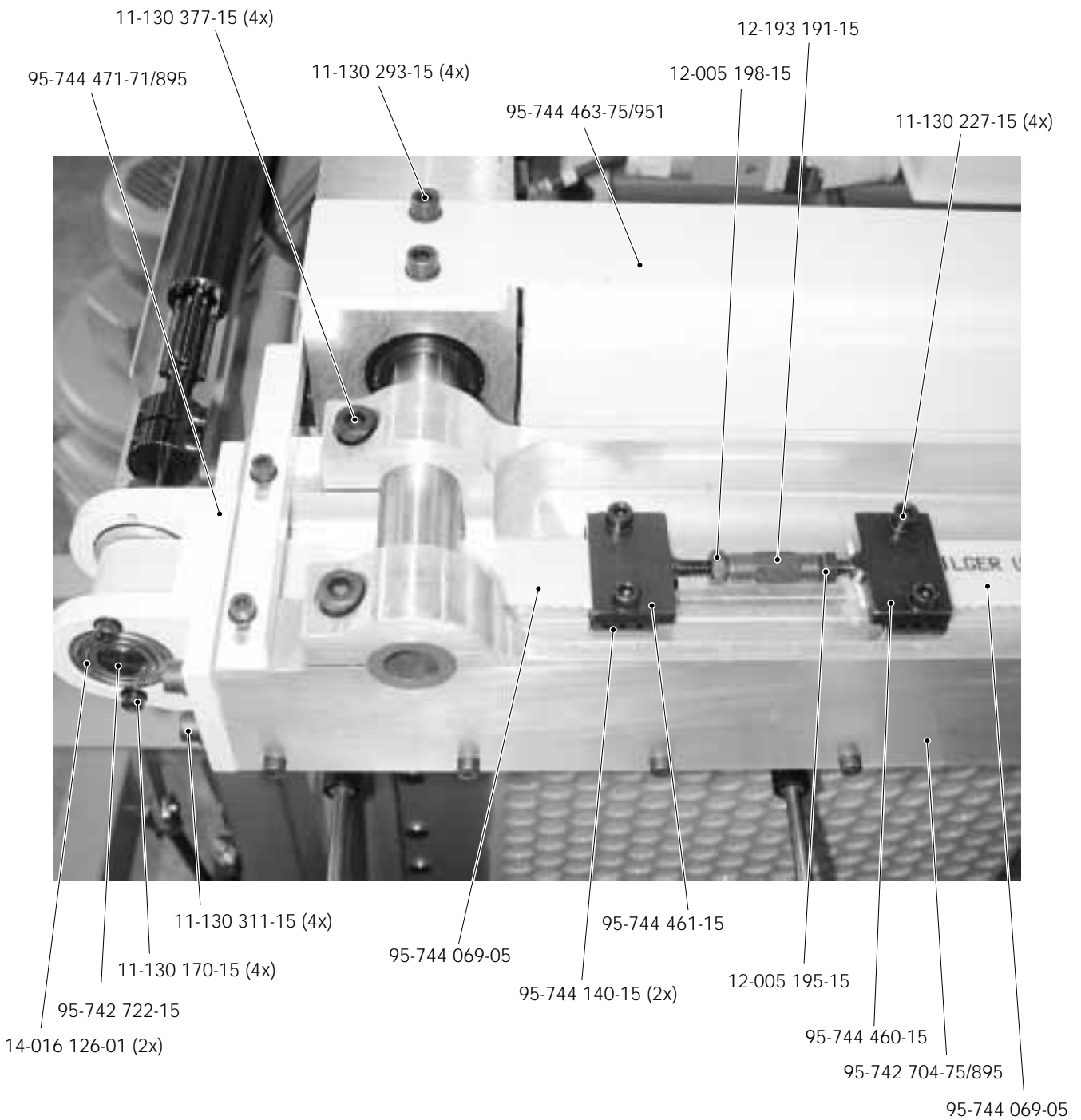
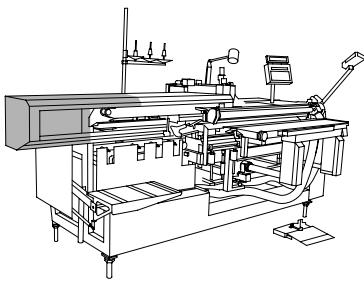

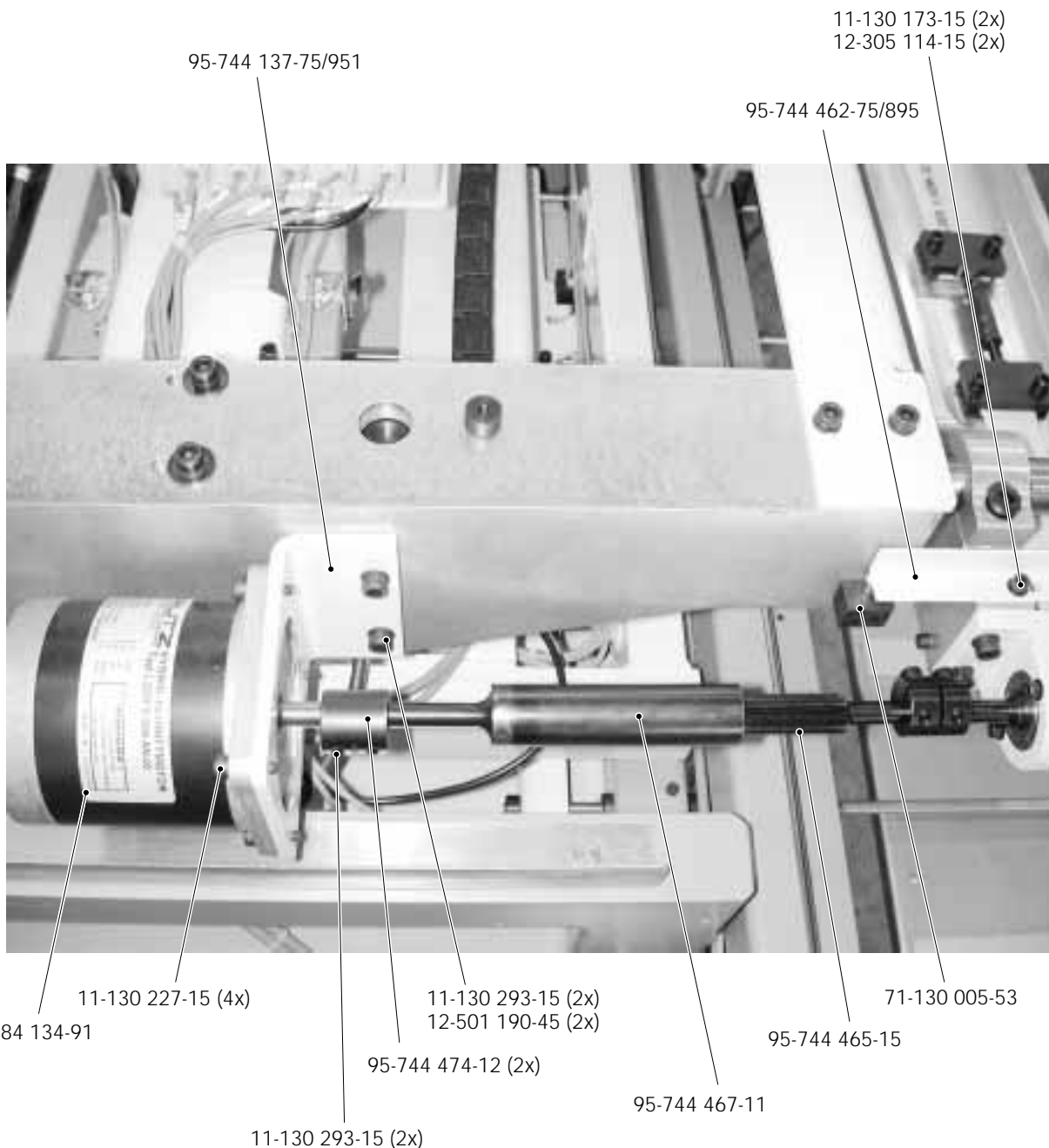
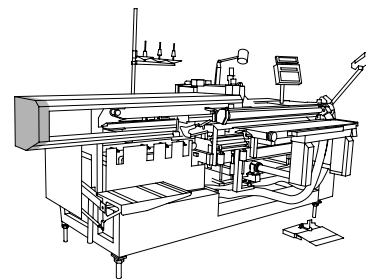

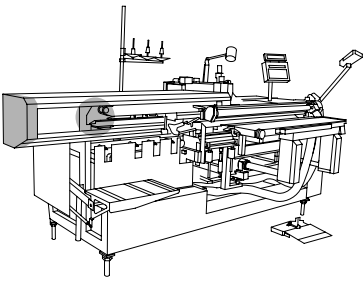

X-Y-Antrieb
 X-Y drive
 Système de commande X-Y
 Grupo de accionamiento "X-Y" PFAFF 3519-3/12

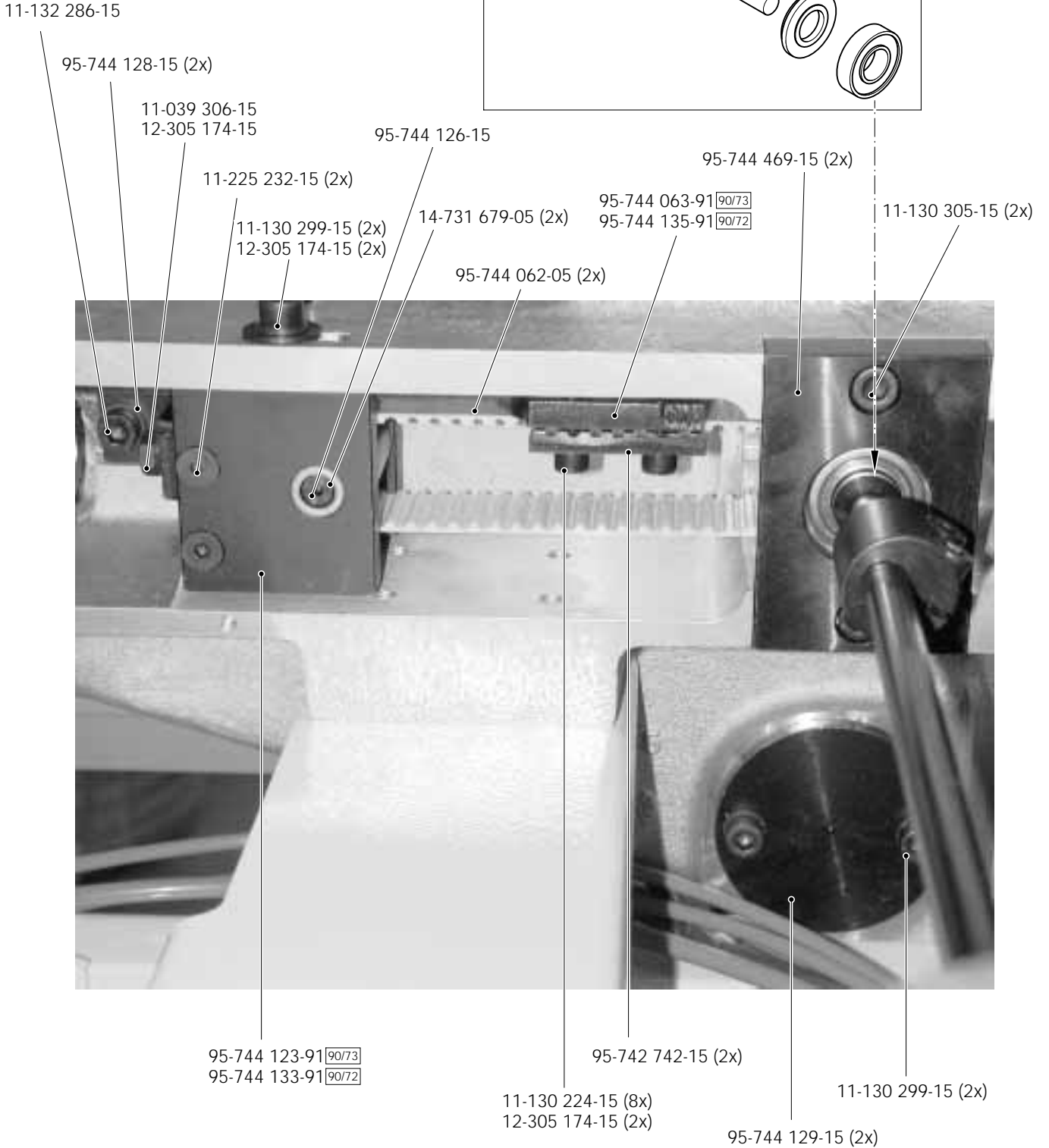
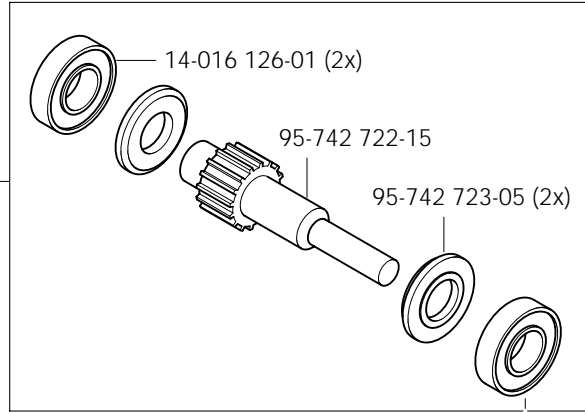

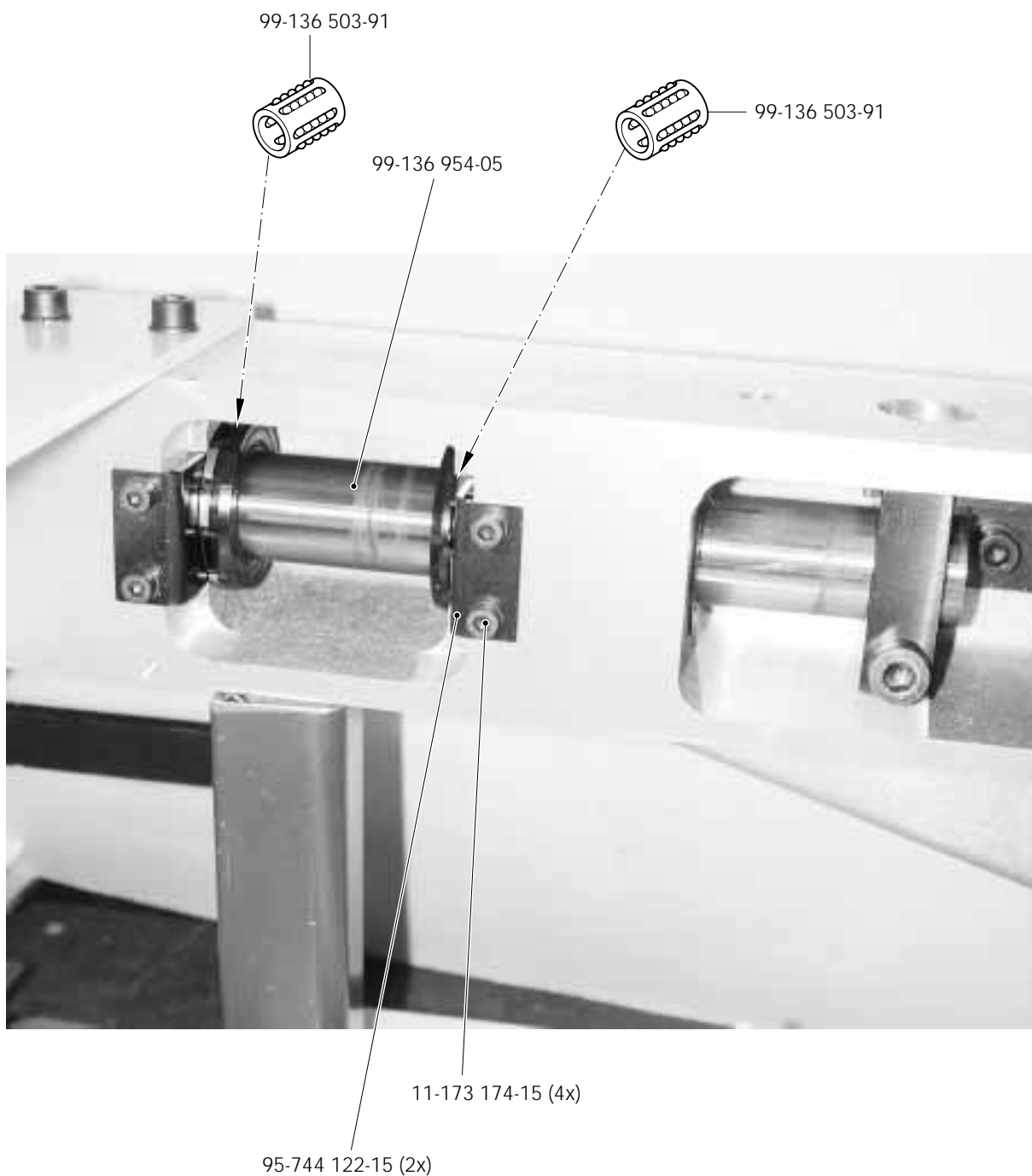
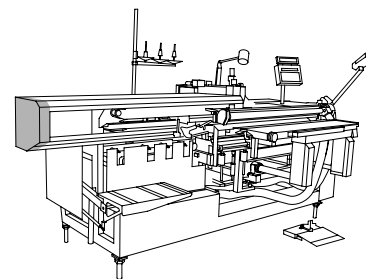

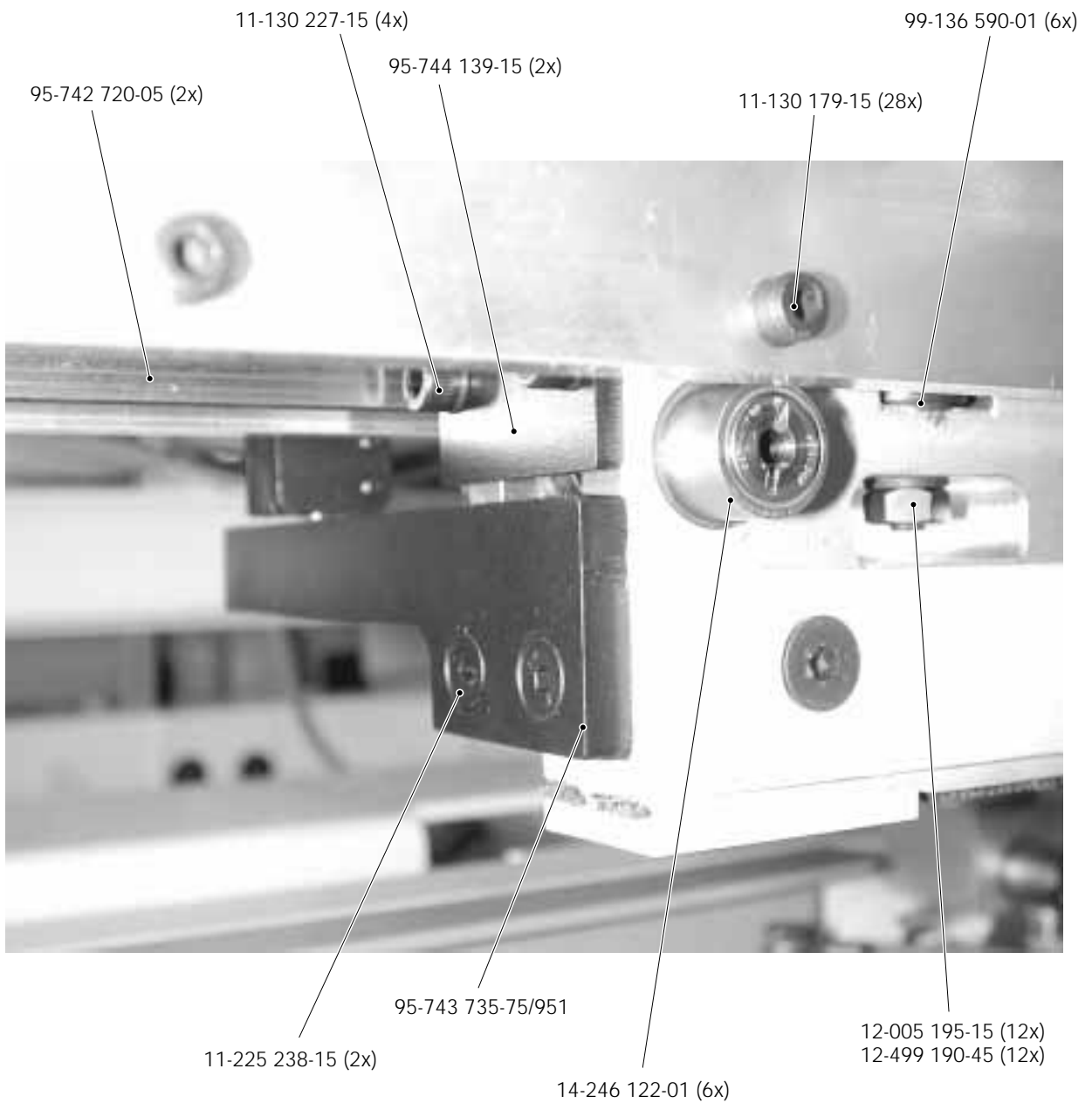
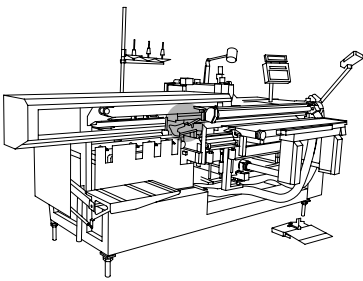

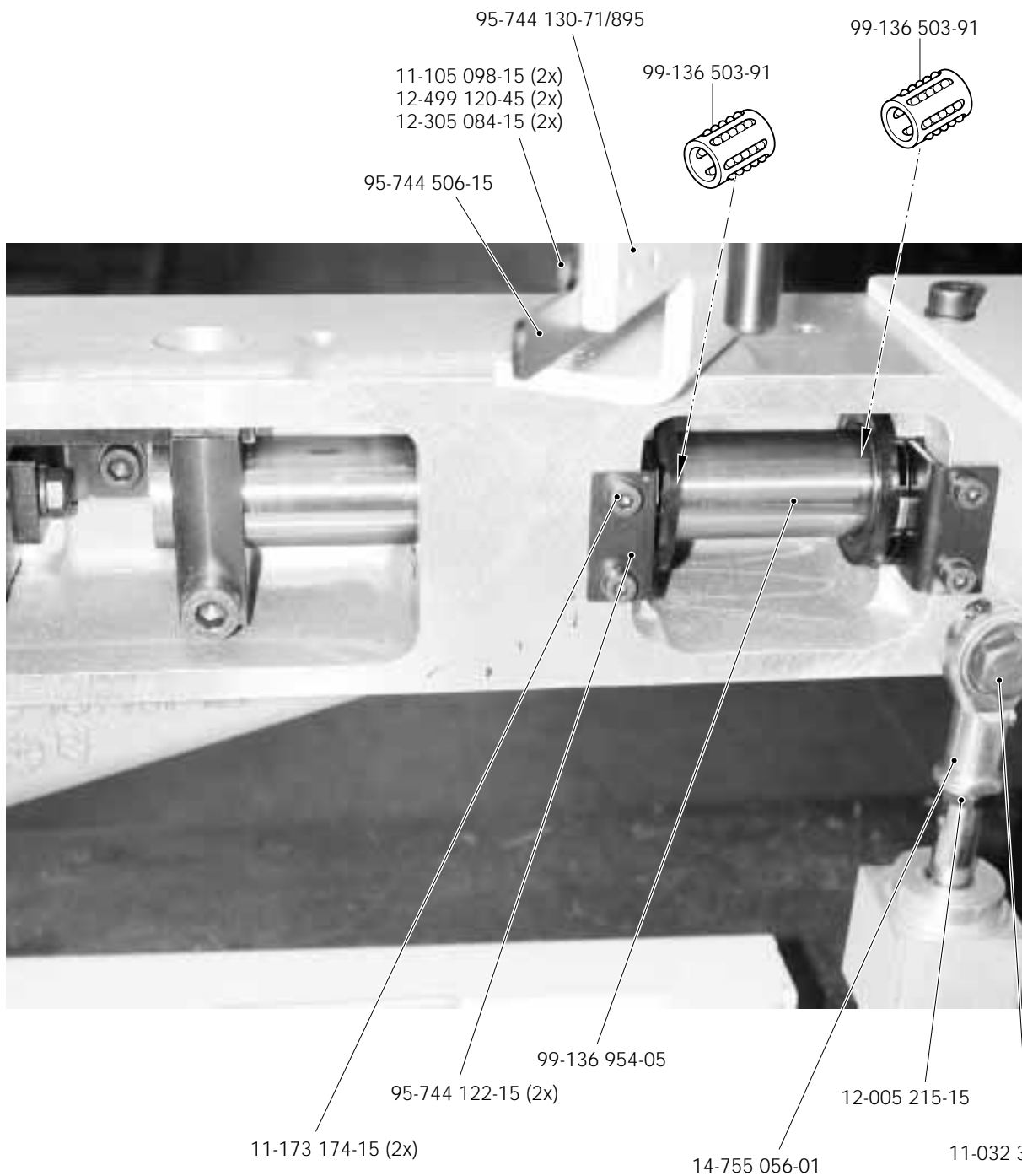
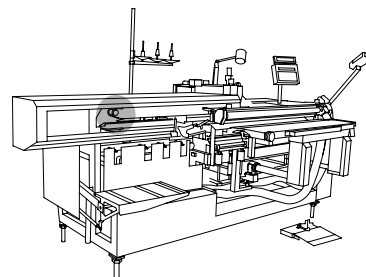

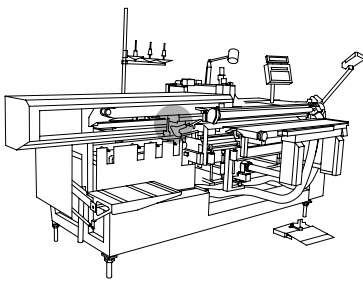

X-Y-Antrieb
 X-Y drive
 Système de commande X-Y
 Grupo de accionamiento "X-Y" PFAFF 3519-3/12

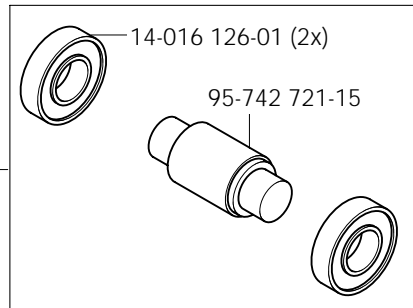

Anschluß siehe Seite 14-3
 For connection see page 14-3
 Raccord, cf. page 14-3
 Para la conexión, véase la pág.14-3

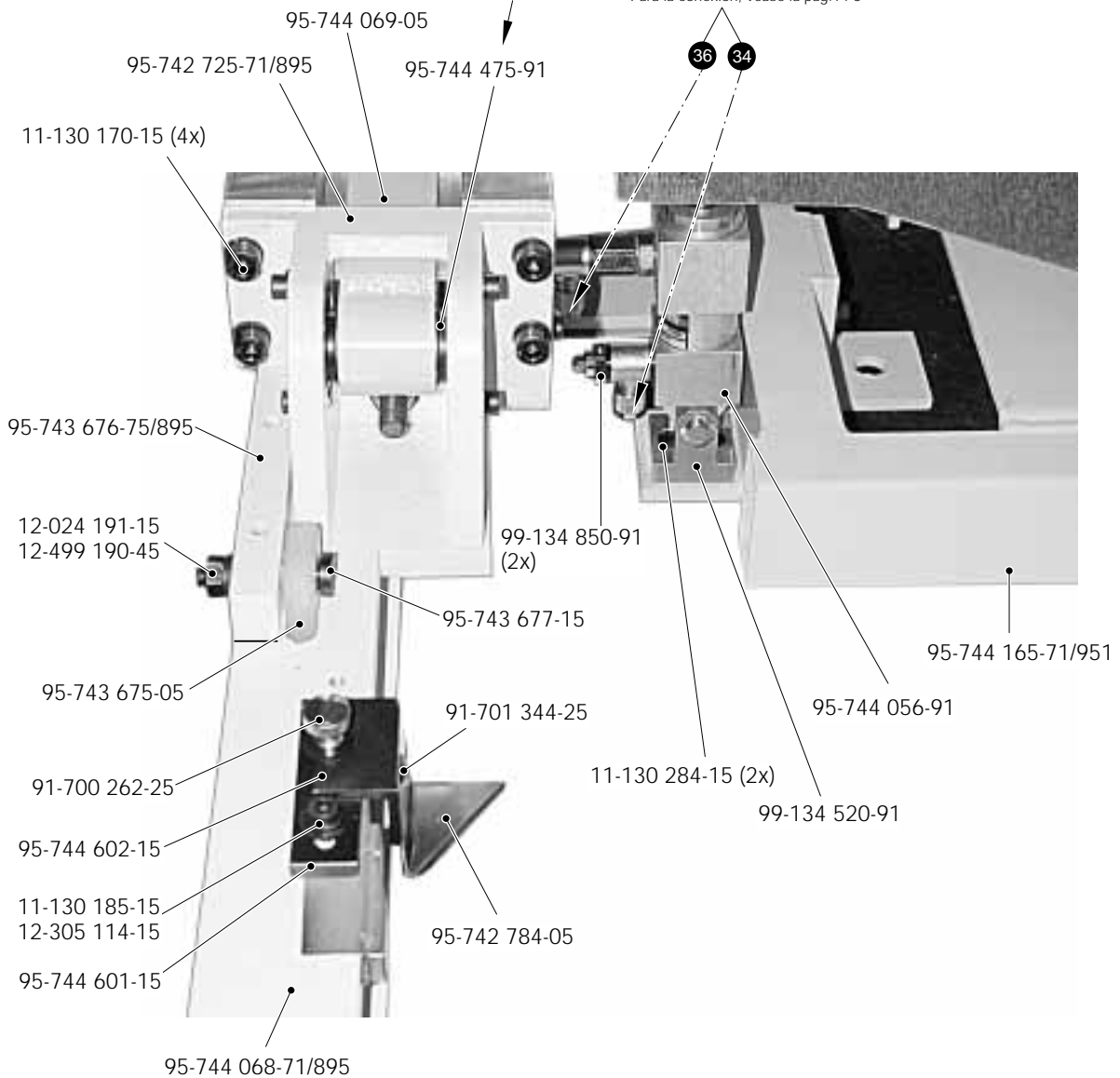

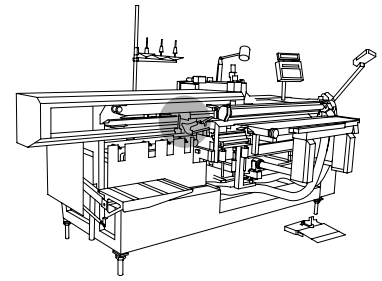

95-742 684-15

Anschluß siehe Seite 14-3
For connection see page 14-3
Raccord, cf. page 14-3
Para la conexión, véase la pág. 14-3

51

Anschluß siehe Seite 14-3
For connection see page 14-3
Raccord, cf. page 14-3
Para la conexión, véase la pág. 14-3

53

11-130 251-15

12-005 175-15

18-378 008-91

18-378 001-91

99-135 548-91

11-130 254-15 (2x)

95-744 312-71/893

99-135 254-91

95-743 747-15

16-041 035-21

95-744 305-71/893

99-136 901-91

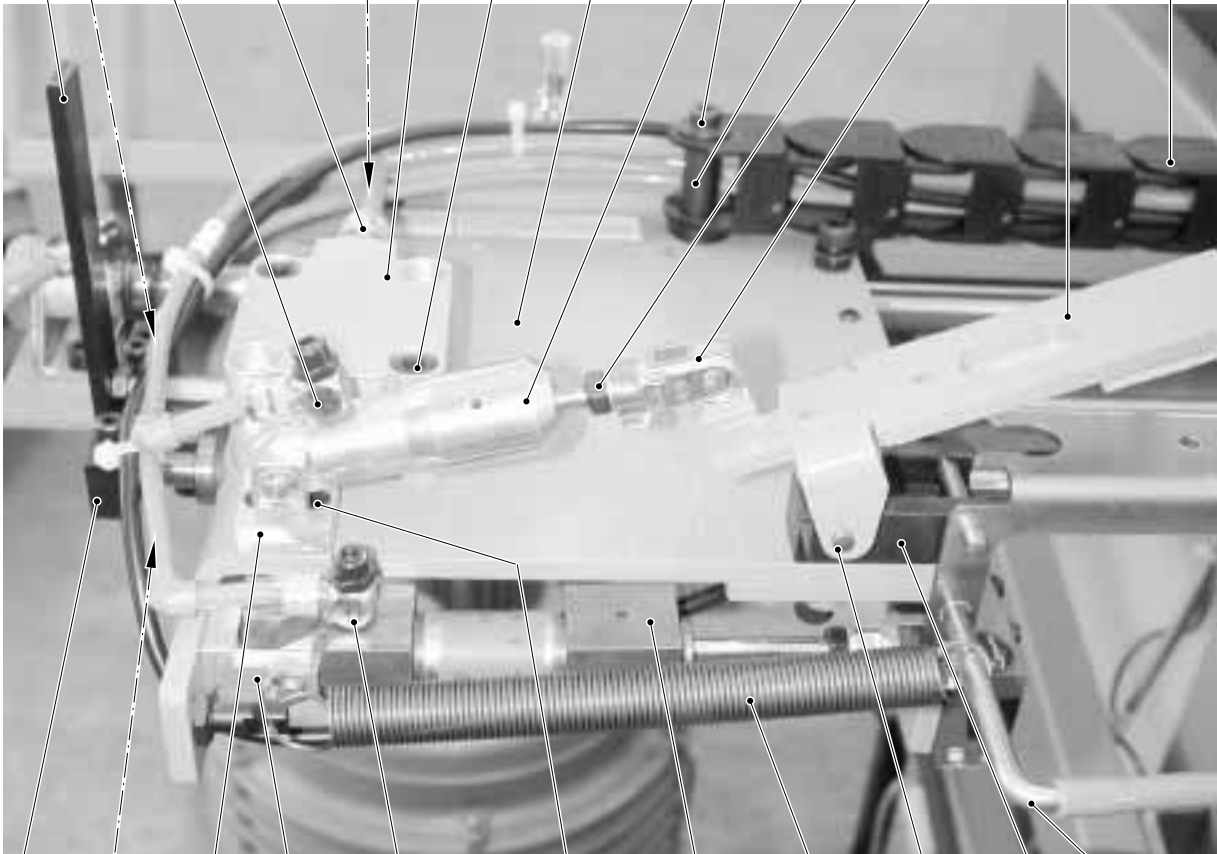

95-743 683-15

52

Anschluß siehe Seite 14-3
For connection see page 14-3
Raccord, cf. page 14-3
Para la conexión, véase la pág. 14-3

99-134 960-91

99-134 960-91

18-378 008-91

99-136 433-91

91-107 663-05

13-033 277-05

95-744 309-01

95-744 418-15

11-130 179-15 (2x)

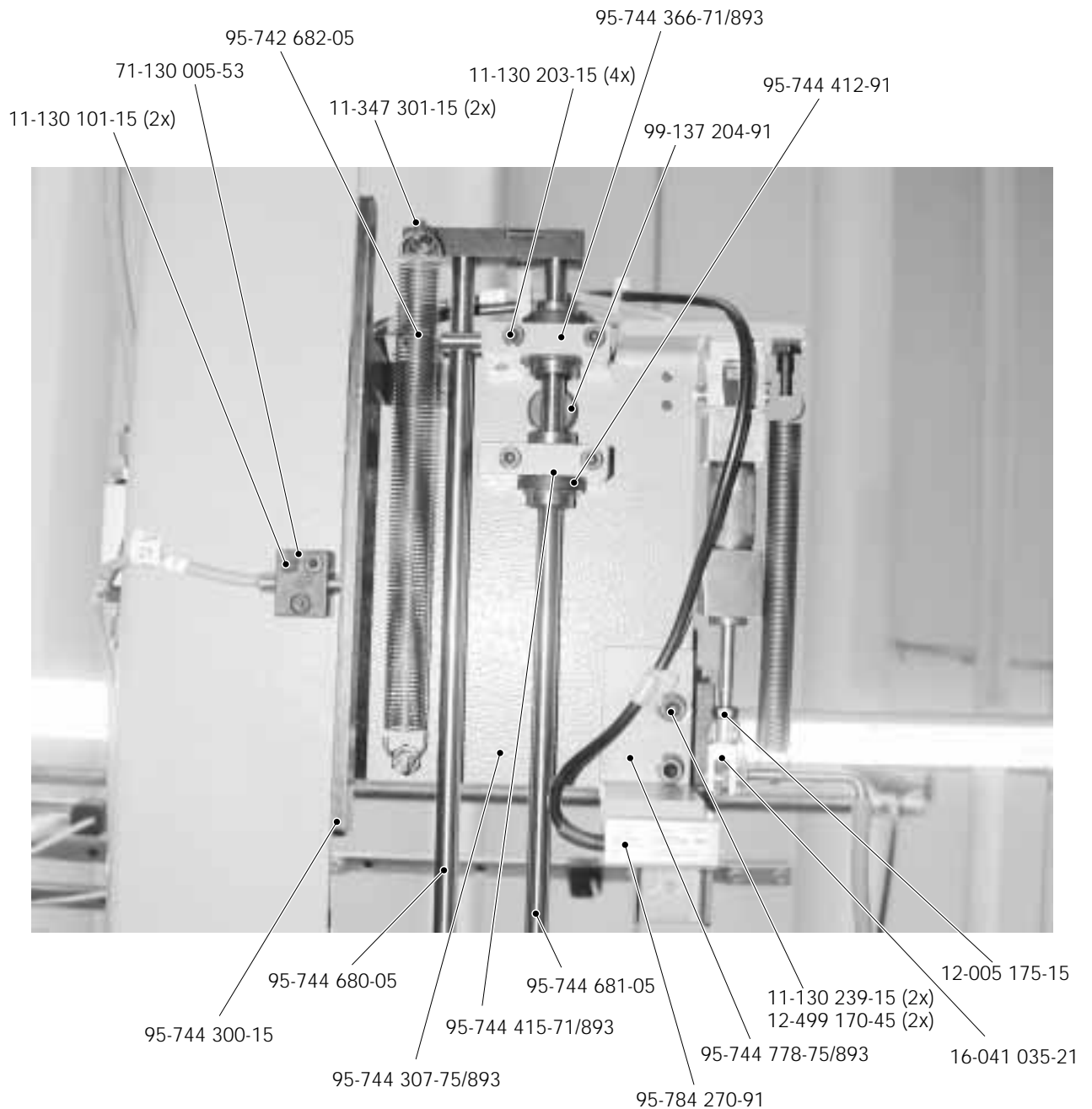
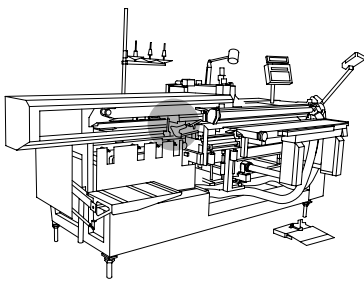

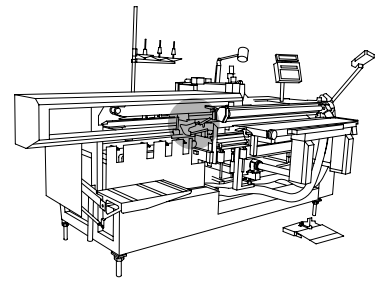

18-378 009-91



99-136 700-55 (2x)

11-130 101-15 (2x)

71-130 005-53

11-132 232-15 (4x)

12-305 144-15 (4x)

12-024 171-15 (4x)



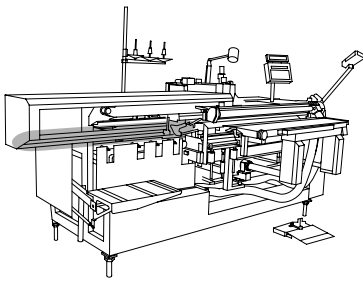

Stapler
Stacker
Empileur
Apilador PFAFF 3519-3/12

11-130 101-15 (2x)
71-130 005-53



18-378 009-91

95-744 295-75/893

99-136 911-91

95-744 348-05

91-700 335-25 (6x)

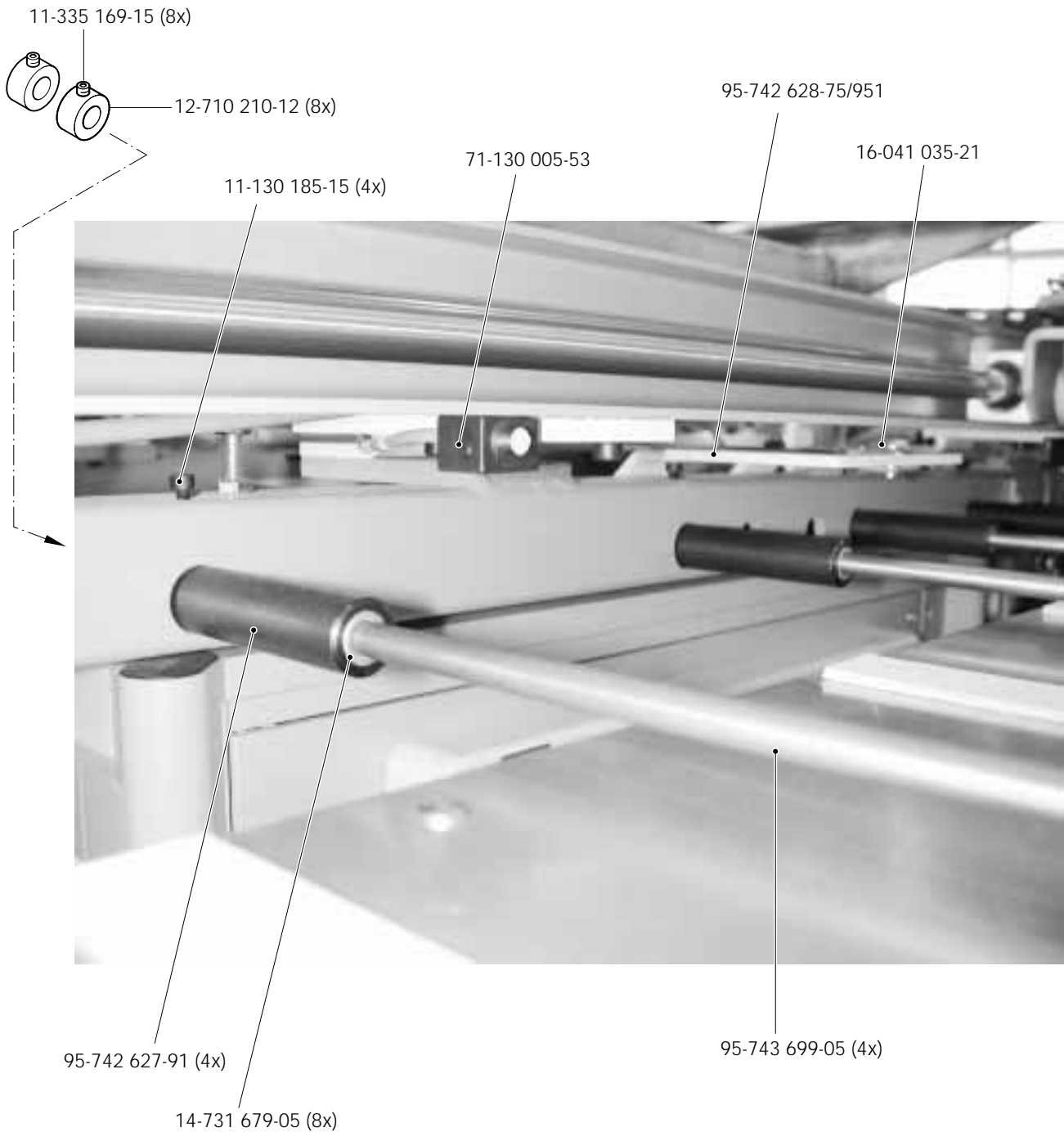
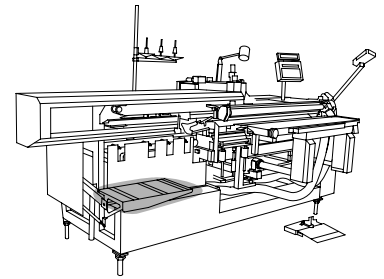

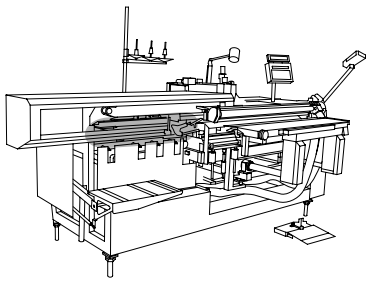

Anschluß siehe Seite 14-3
For connection see page 14-3
Raccord, cf. page 14-3
Para la conexión, véase la pág. 14-3



49
Anschluß siehe Seite 14-3
For connection see page 14-3
Raccord, cf. page 14-3
Para la conexión, véase la pág. 14-3

99-134 851-91 (2x)

99-136 030-91

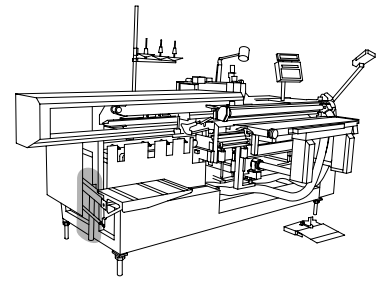

Anschluß siehe Seite 14-4
For connection see page 14-4
Raccord, cf. page 14-4
Para la conexión, véase la pág. 14-4

62

61

14-731 913-05 (2x)

12-710 250-02

18-378 001-91



18-378 008-91

99-115 505-91 (2x)

99-136 205-91

99-134 591-91

18-277 001-91 (2x)

95-744 349-11

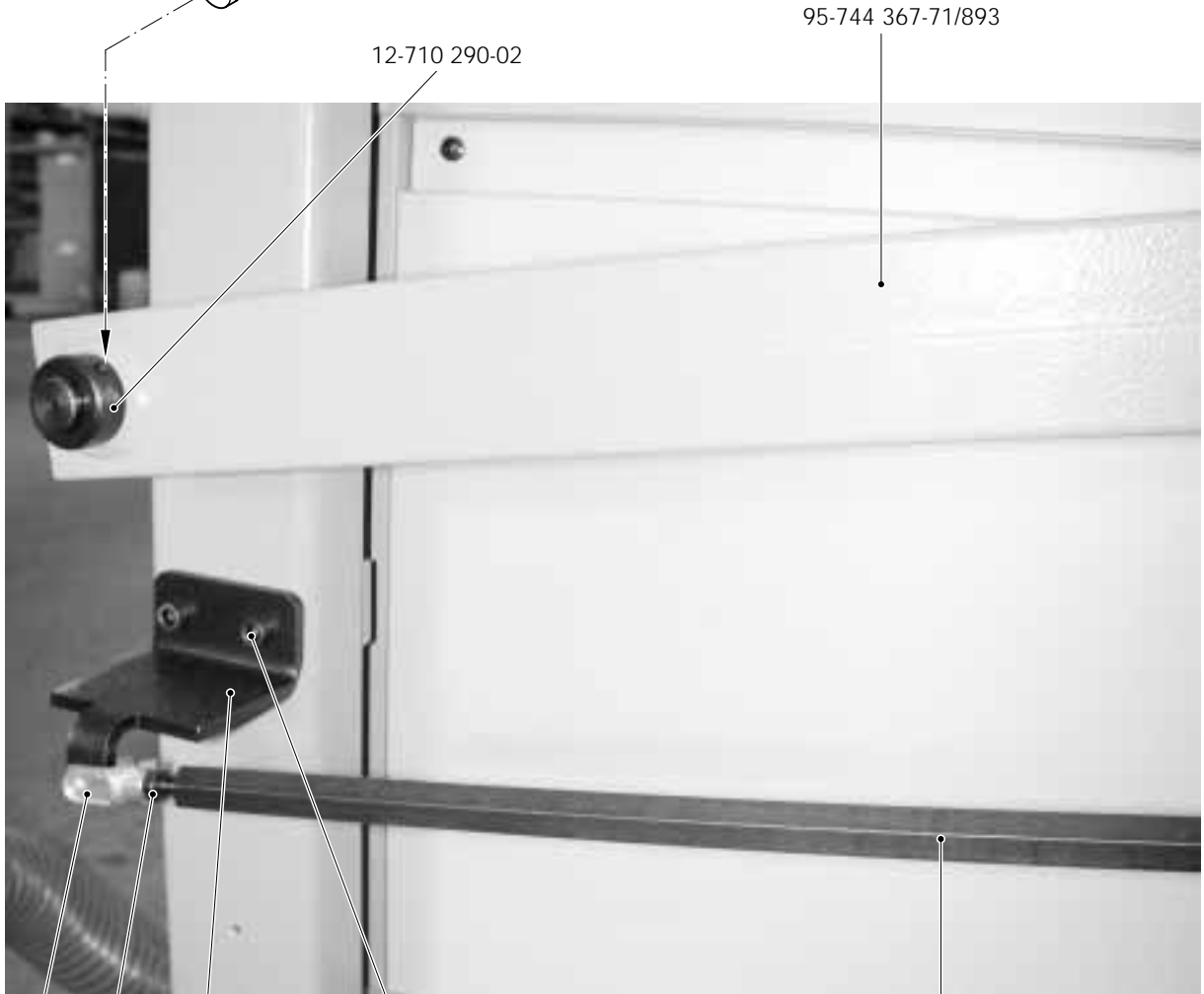
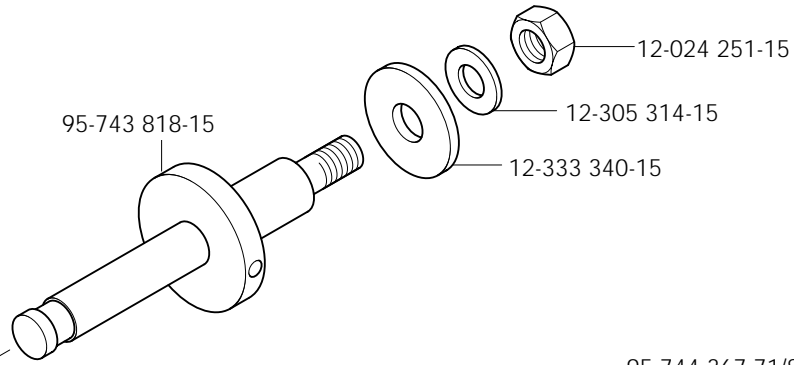
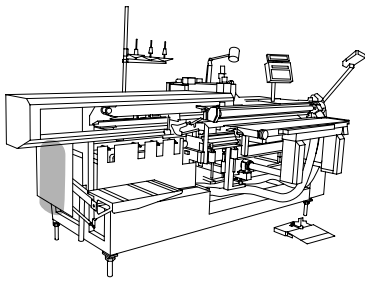

16-041 055-21

95-744 369-15

12-024 191-15

11-130 332-15 (2x)
12-024 191-15 (2x)
12-499 190-45 (2x)

95-744 352-15

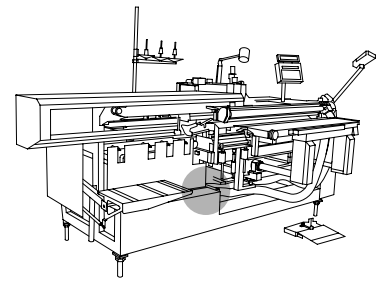

Anschluß siehe Seite 14-4
 For connection see page 14-4
 Raccord, cf. page 14-4
 Para la conexión, véase la pág. 14-4

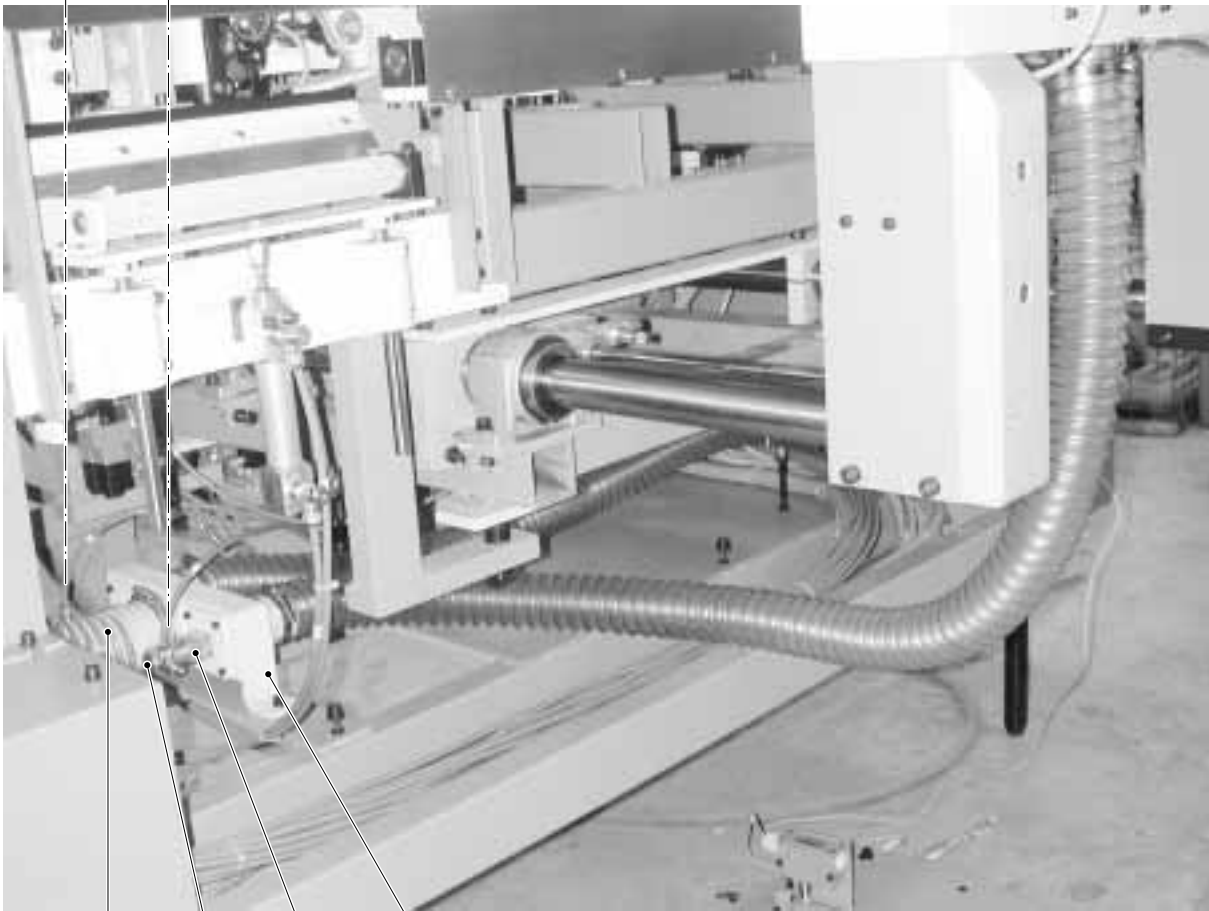
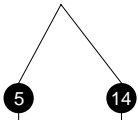

- 95-743 315-05
- 18-378 001-91 (2x)
- 99-135 614-91 (2x)
- 95-744 142-71/951

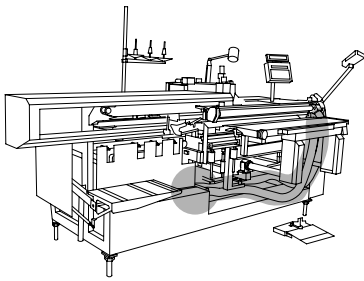

Verteiler für Saugereinrichtung
 Distributor for vacuum system
 Distributeur de dispositif d'aspiration
 Distribuidor para dispositivo de aspiración PFAFF 3519-3/12



17-518 100-51 (2x)

17-518 090-51 (4x)

95-743 314-05

95-743 313-05

95-744 145-15

95-743 307-05

12-335 171-15

12-005 175-15

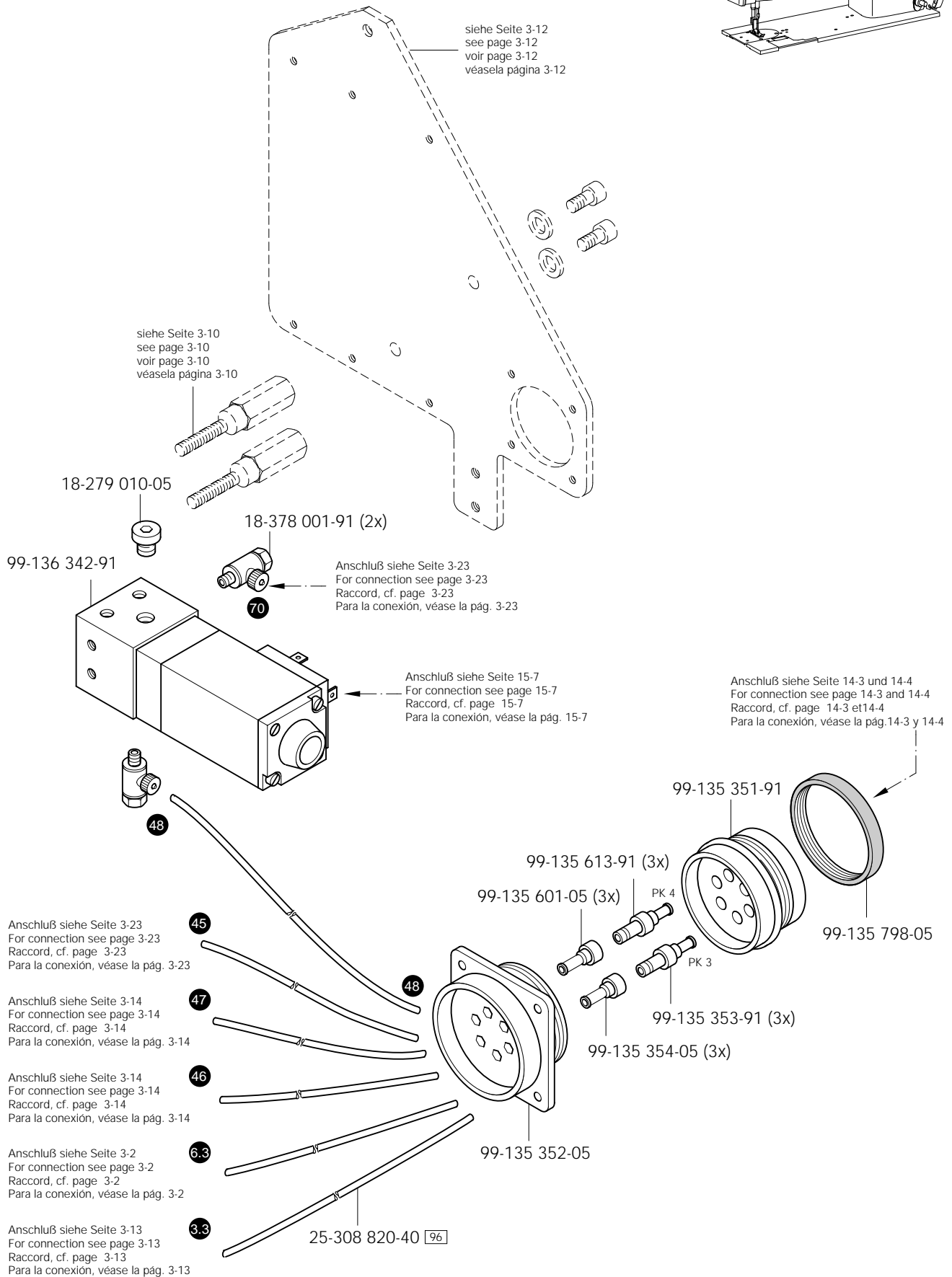
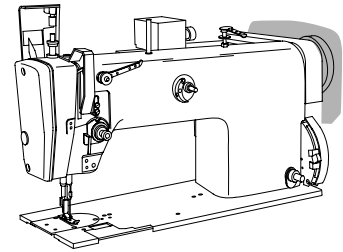

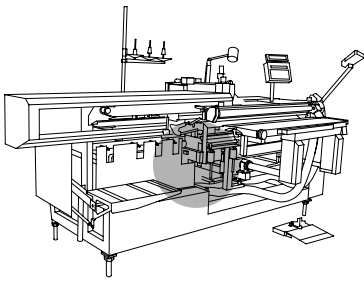

95-743 613-71/893

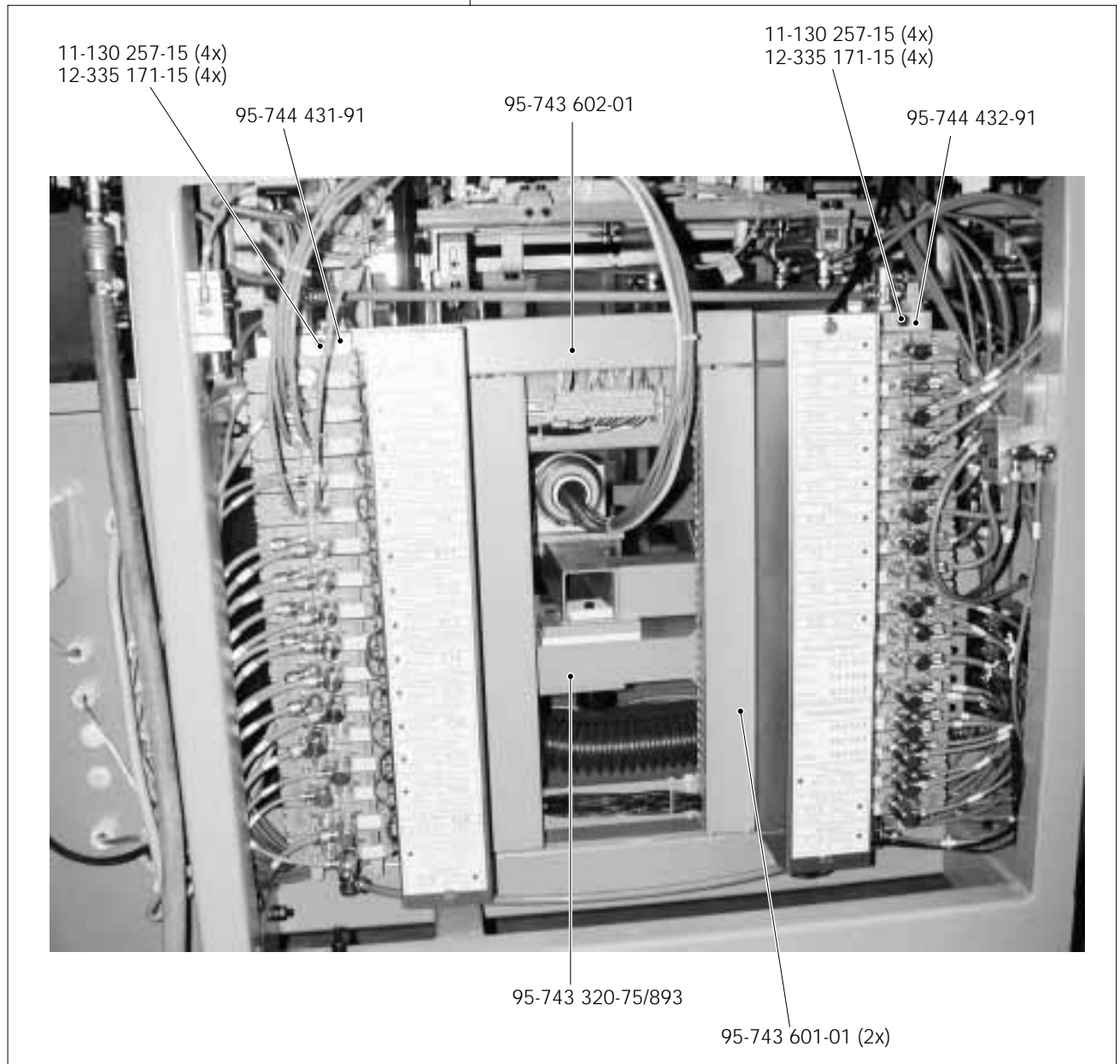

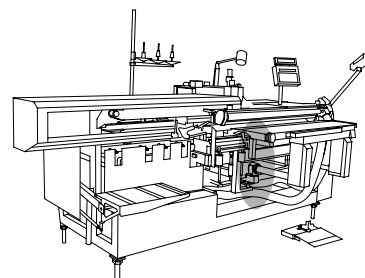

95-744 431-91

99-136 134-91

99-136 129-91 (15x)

Anschluß siehe Seite 14-1
 For connection see page 14-1
 Raccord, cf. page 14-1
 Para la conexión, véase la pág. 14-1

6.3

Anschluß siehe Seite 7-1
 For connection see page 7-1
 Raccord, cf. page 7-1
 Para la conexión, véase la pág. 7-1

10

11

Anschluß siehe Seite 7-2
 For connection see page 7-2
 Raccord, cf. page 7-2
 Para la conexión, véase la pág. 7-2

17

18

Anschluß siehe Seite 9-2
 For connection see page 9-2
 Raccord, cf. page 9-2
 Para la conexión, véase la pág. 9-2

12

13

Anschluß siehe Seite 7-3
 For connection see page 7-3
 Raccord, cf. page 7-3
 Para la conexión, véase la pág. 7-3

15

16

Anschluß siehe Seite 8-3
 For connection see page 8-3
 Raccord, cf. page 8-3
 Para la conexión, véase la pág. 8-3

19

20

Anschluß siehe Seite 8-1
 For connection see page 8-1
 Raccord, cf. page 8-1
 Para la conexión, véase la pág. 8-1

21

22

Anschluß siehe Seite 8-4
 For connection see page 8-4
 Raccord, cf. page 8-4
 Para la conexión, véase la pág. 8-4

23

24

Anschluß siehe Seite 8-4
 For connection see page 8-4
 Raccord, cf. page 8-4
 Para la conexión, véase la pág. 8-4

25

26

Anschluß siehe Seite 11-9
 For connection see page 11-9
 Raccord, cf. page 11-9
 Para la conexión, véase la pág. 11-9

34

36

Anschluß siehe Seite 12-6
 For connection see page 12-6
 Raccord, cf. page 12-6
 Para la conexión, véase la pág. 12-6

49

50

Anschluß siehe Seite 14-1
 For connection see page 14-1
 Raccord, cf. page 14-1
 Para la conexión, véase la pág. 14-1

45

51

Anschluß siehe Seite 12-1
 For connection see page 12-1
 Raccord, cf. page 12-1
 Para la conexión, véase la pág. 12-1

51

Anschluß siehe Seite 12-1
 For connection see page 12-1
 Raccord, cf. page 12-1
 Para la conexión, véase la pág. 12-1

52

Anschluß siehe Seite 12-1
 For connection see page 12-1
 Raccord, cf. page 12-1
 Para la conexión, véase la pág. 12-1

53

Anschluß siehe Seite 19-1
 For connection see page 19-1
 Raccord, cf. page 19-1
 Para la conexión, véase la pág. 19-1

86

18-378 001-91

Y 32

18-372 009-91 (4x)

Y 6

18-378 010-91 (2x)

Y 10

18-372 009-91 (2x)

Y 7

18-378 001-91 (2x)

Y 9

18-378 001-91 (2x)

Y 11

18-378 001-91 (2x)

Y 12

18-378 001-91 (2x)

Y 13

18-378 001-91 (2x)

Y 14

18-378 001-91 (2x)

Y 19

18-378 010-91

Y 24

18-378 010-91

Y 21

18-378 001-91

Y 25

99-115 591-91 (4x)

Y 26

Y 27

18-378 001-91

Y 74

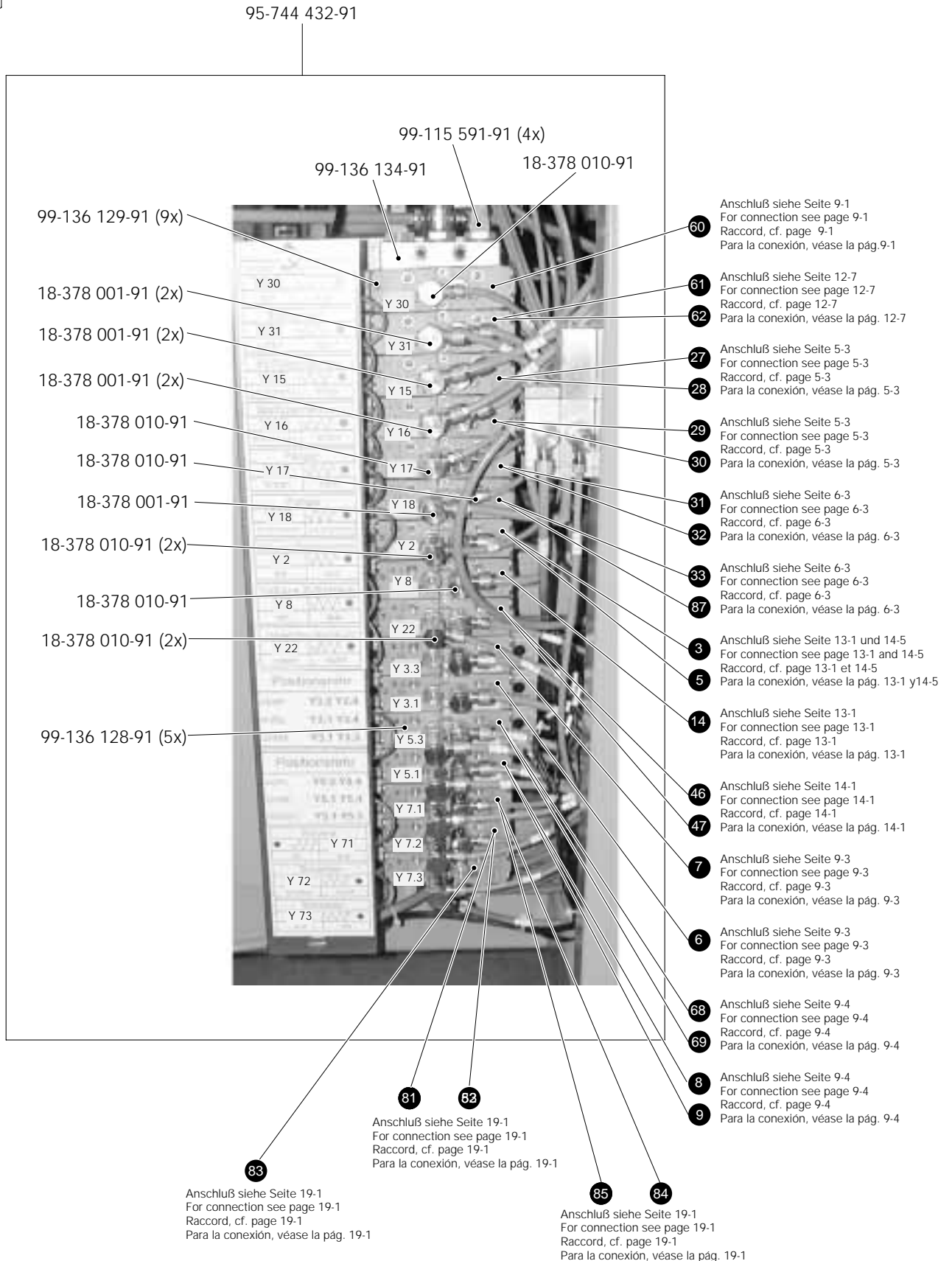
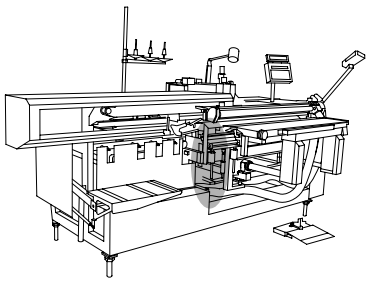

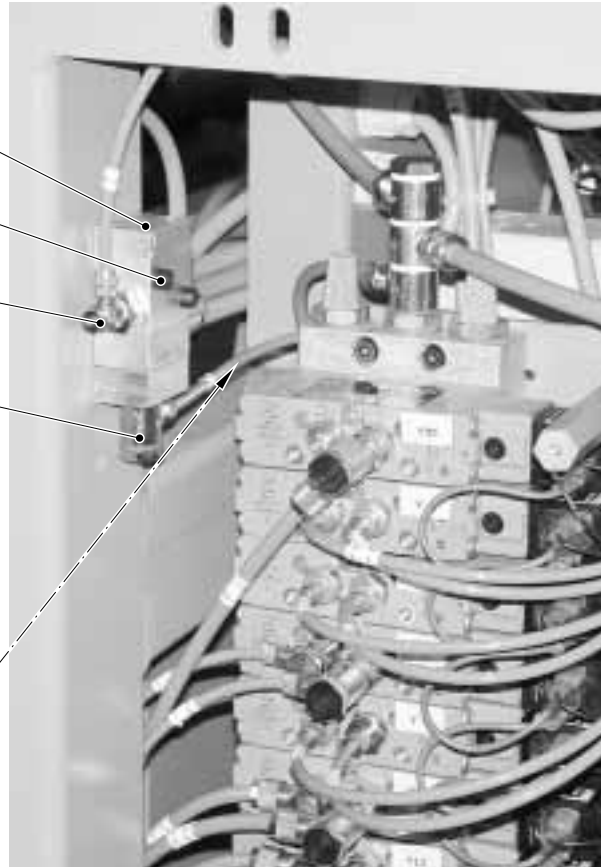
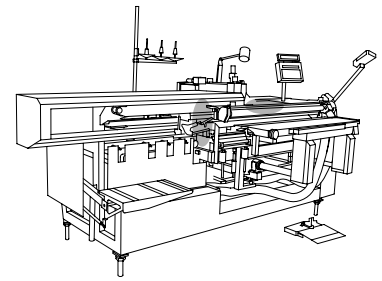

99-133 124-91

11-130 197-15 (2x)
12-305 114-15 (2x)

99-135 490-91

18-378 001-91

3
Anschluß siehe Seite 14-4
For connection see page 14-4
Raccord, cf. page 14-4
Para la conexión, véase la pág.14-4

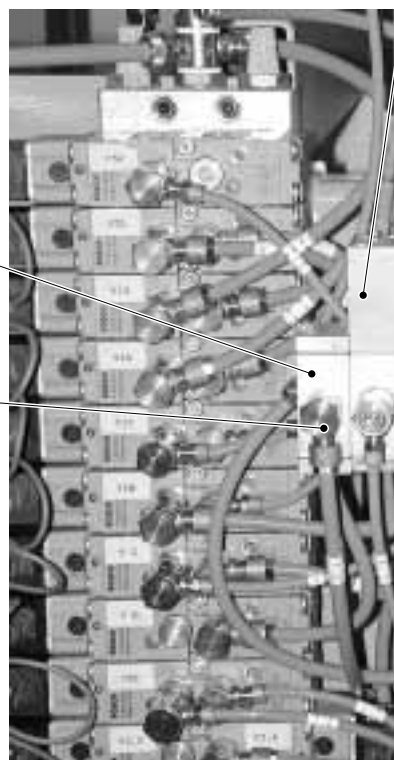

99-133 125-91

99-133 127-91

18-378 010-91 (3x)



99-136 129-91

11-130 197-15 (2x)

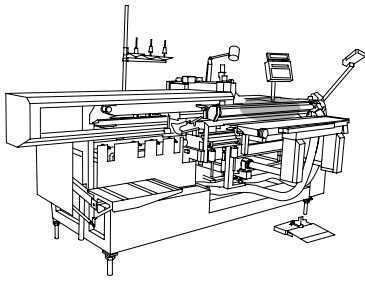

99-136 121-91

18-277 003-91

18-378 004-91

99-137 011-91

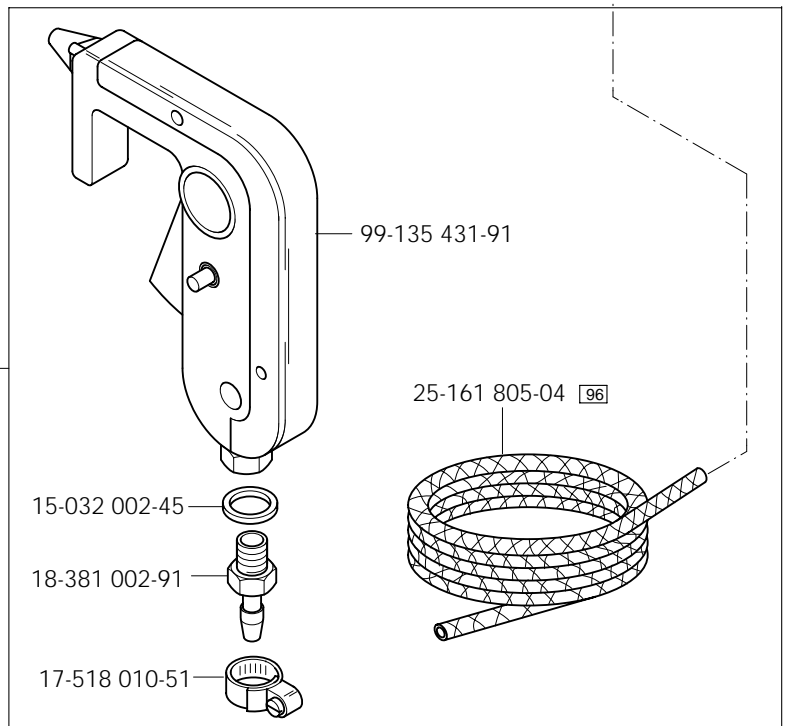

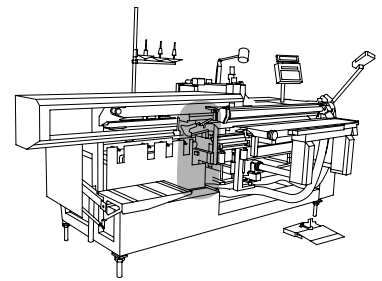

11-130 284-15 (2x)
12-501 190-45 (2x)
12-335 191-15 (2x)

91-086 176-75/893

99-115 589-91

18-378 003-91 (2x)

99-135 496-95

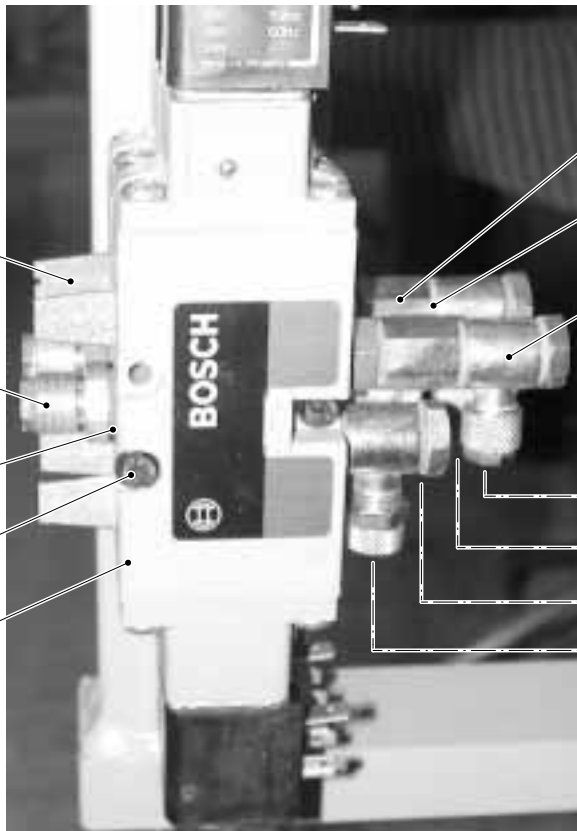

99-133 042-91 (4x)

18-372 001-91 (2x)

15-032 001-45 (2x)

11-106 916-15 (2x)

99-136 128-91 (2x)

18-277 001-91 (2x)

15-032 001-45 (6x)

18-378 001-91 (4x)

71

Anschluß siehe Seite 7-2
For connection see page 7-2
Raccord, cf. page 7-2
Para la conexión, véase la pág. 7-2

72

74

Anschluß siehe Seite 7-4
For connection see page 7-4
Raccord, cf. page 7-4
Para la conexión, véase la pág. 7-4

73

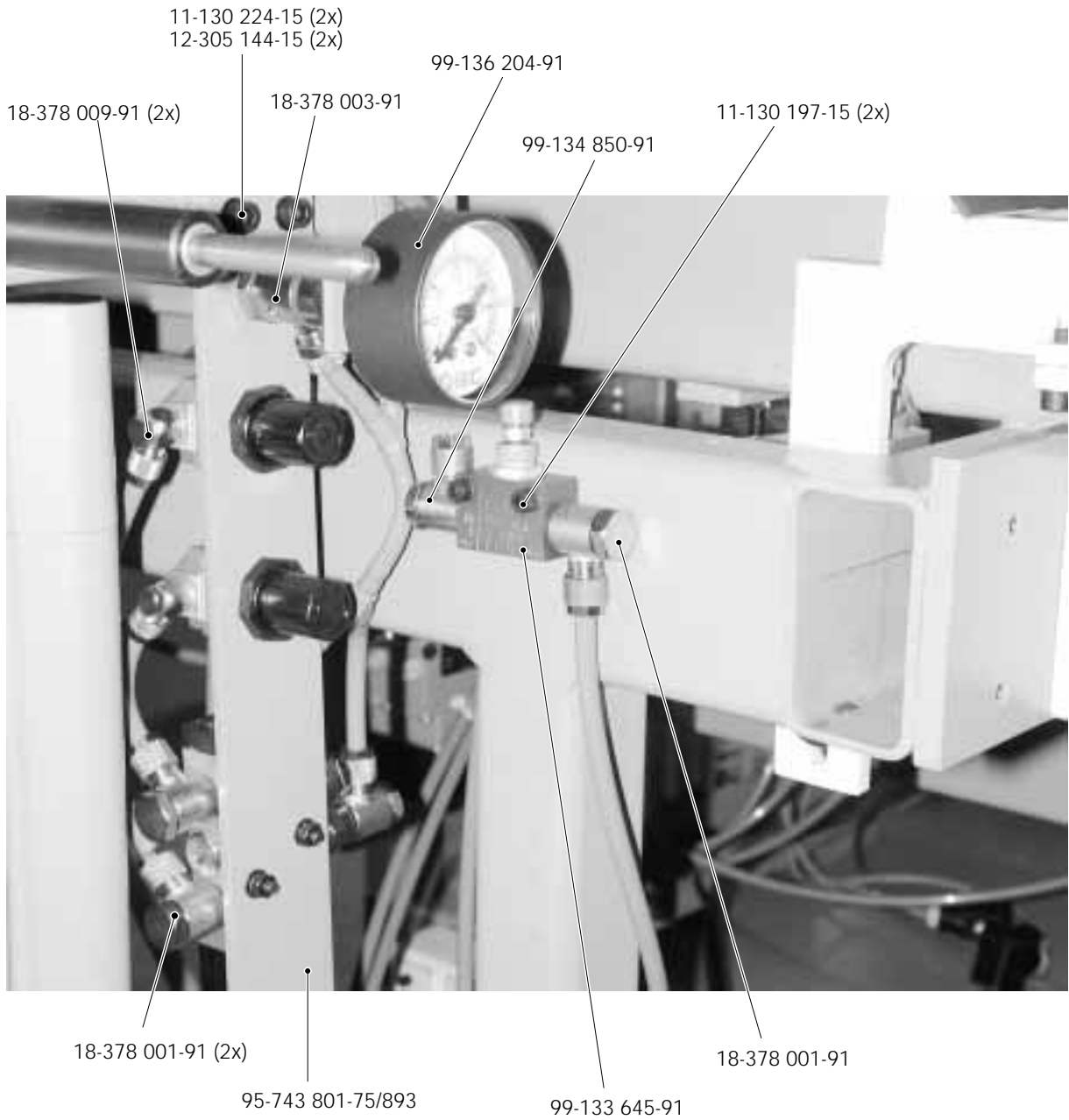
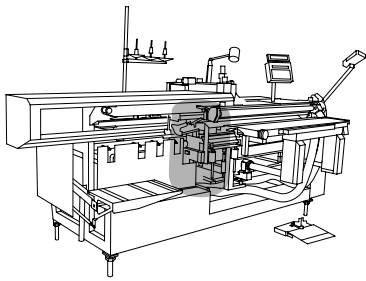

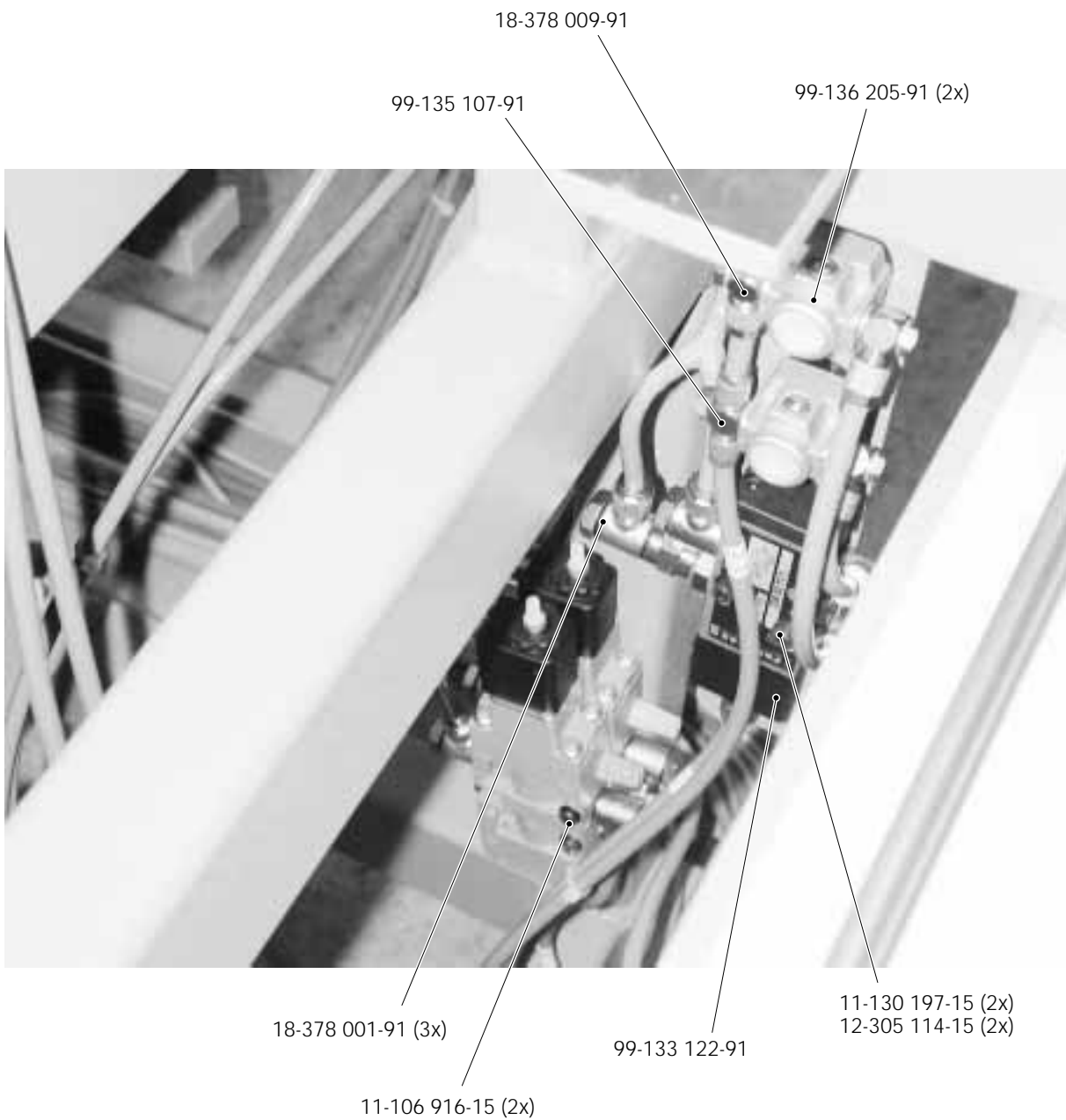
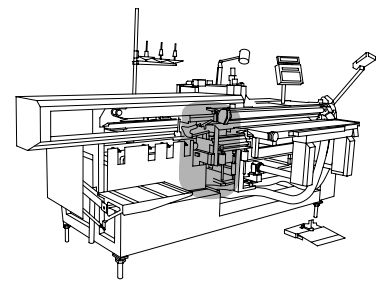

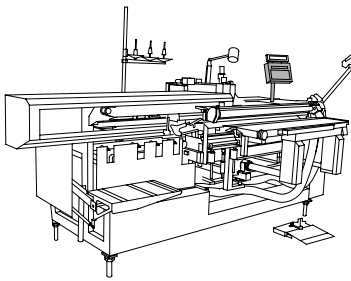

95-784 147-73/001

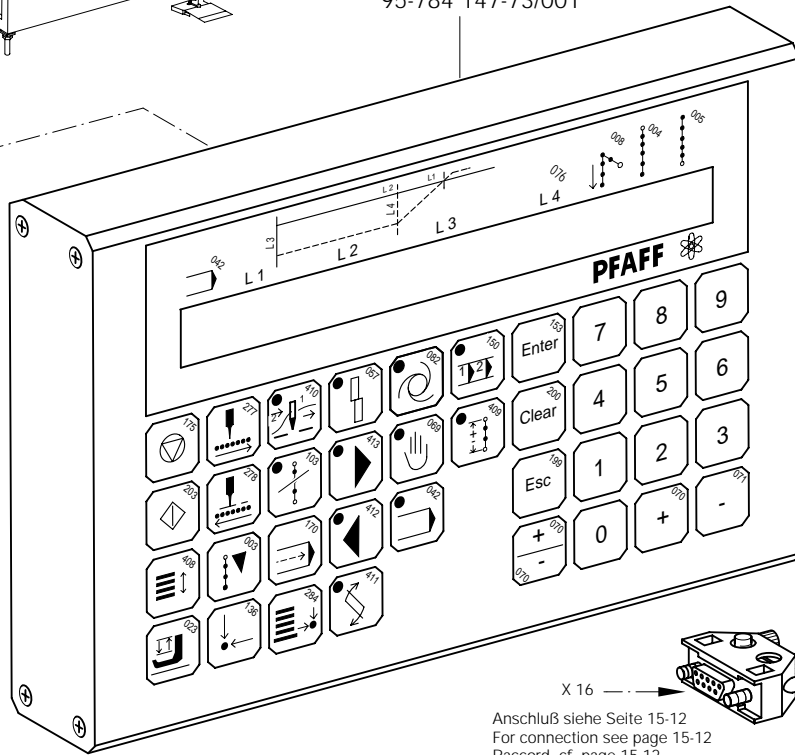

95-784 133-91

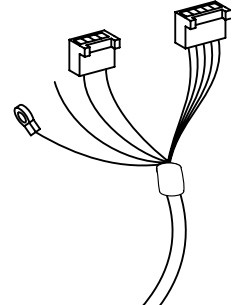

X 16

Anschluß siehe Seite 15-12
For connection see page 15-12
Raccord, cf. page 15-12
Para la conexión, véase la pág. 15-12

91-291 032-91

95-744 330-71/895

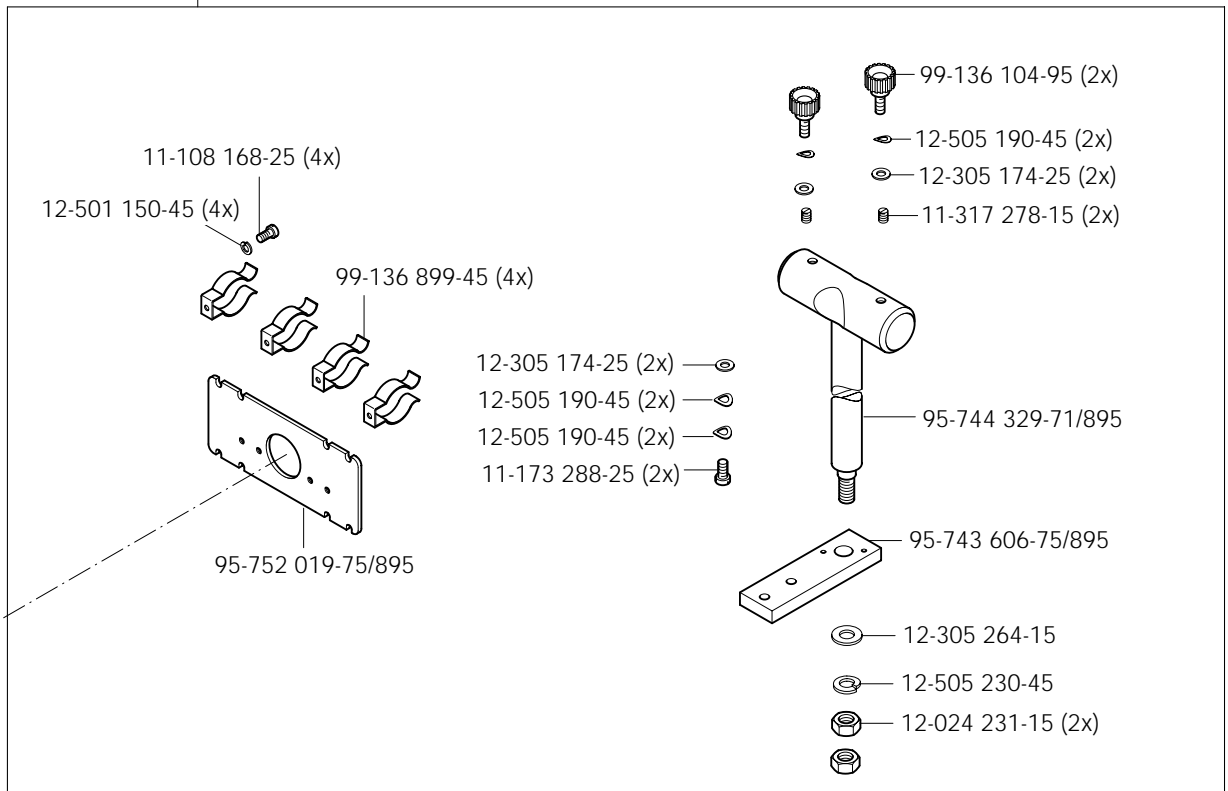

15.01

Bedienfeld
Control panel
Panneau de commande
Panel de mandos

PFAFF 3519-3/12

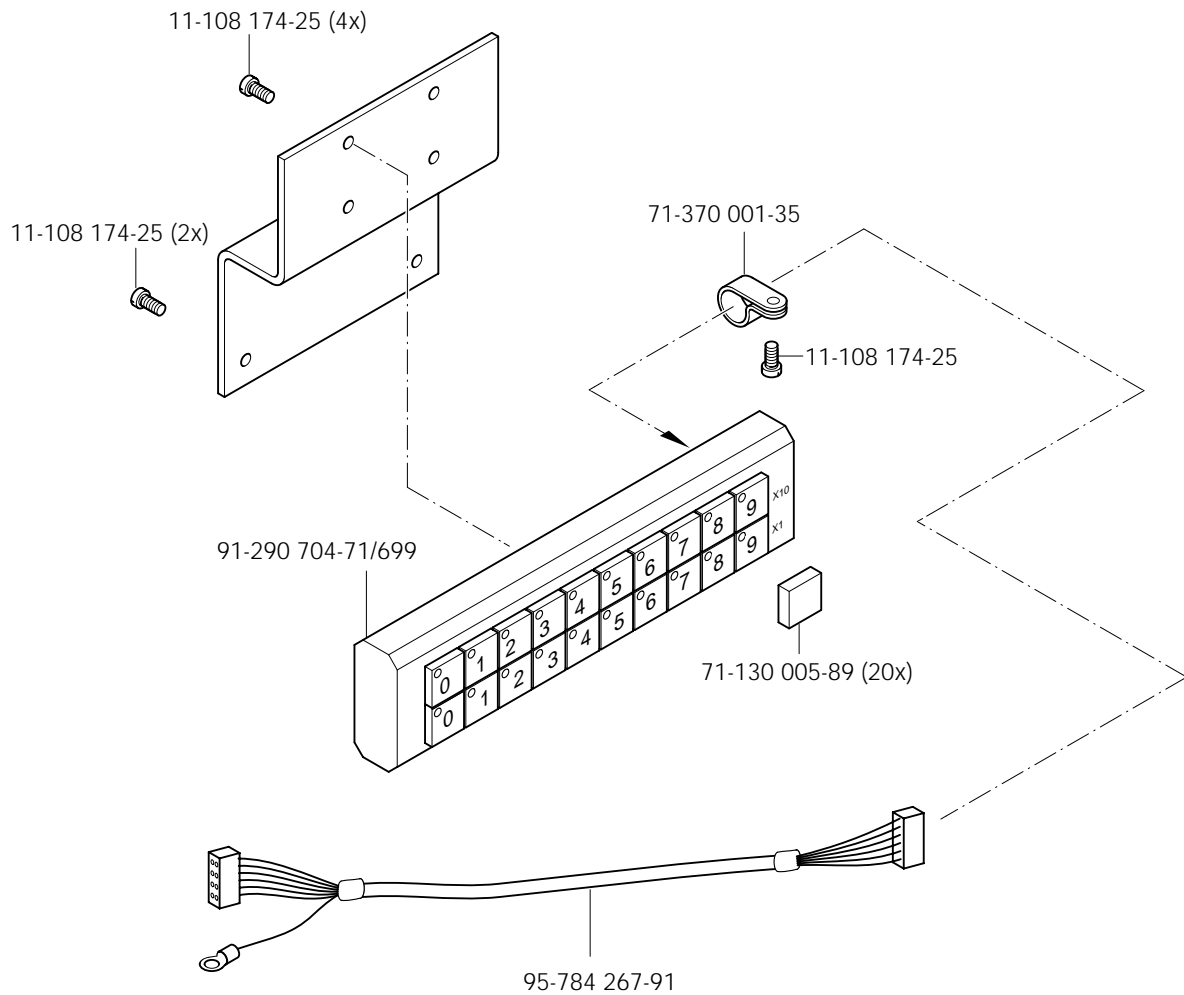
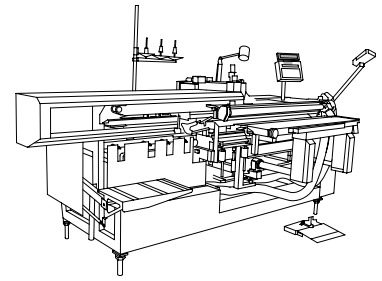

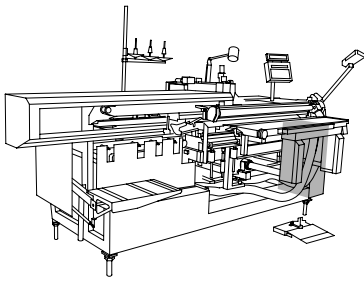

Verteiler für Saugeinrichtung
 Distributor for vacuum system
 Distributeur de dispositif d'aspiration
 Distribuidor para dispositivo de aspiración

PFAFF 3519-3/12

15.02

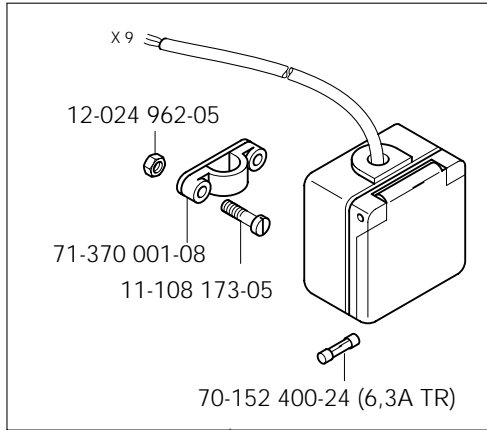

95-783 959-91

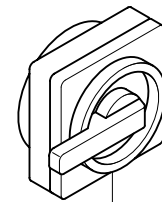
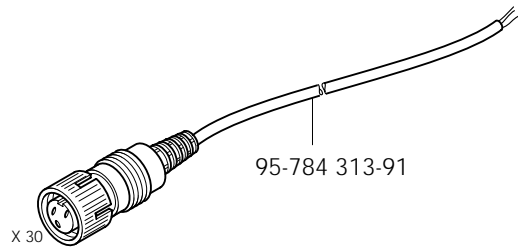

95-784 142-71/893



11-210 174-25 (4x)
 12-024 151-25 (4x)
 12-510 111-25 (4x)

71-250 002-52 (130V, 2W)

15.02

Verteiler für Saugeinrichtung
 Distributor for vacuum system
 Distributeur de dispositif d'aspiration
 Distribuidor para dispositivo de aspiración PFAFF 3519-3/12

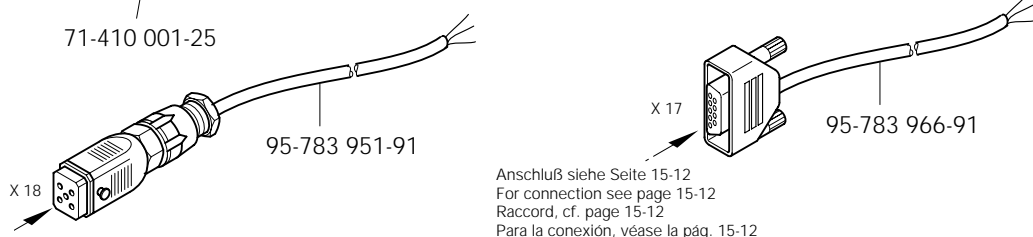
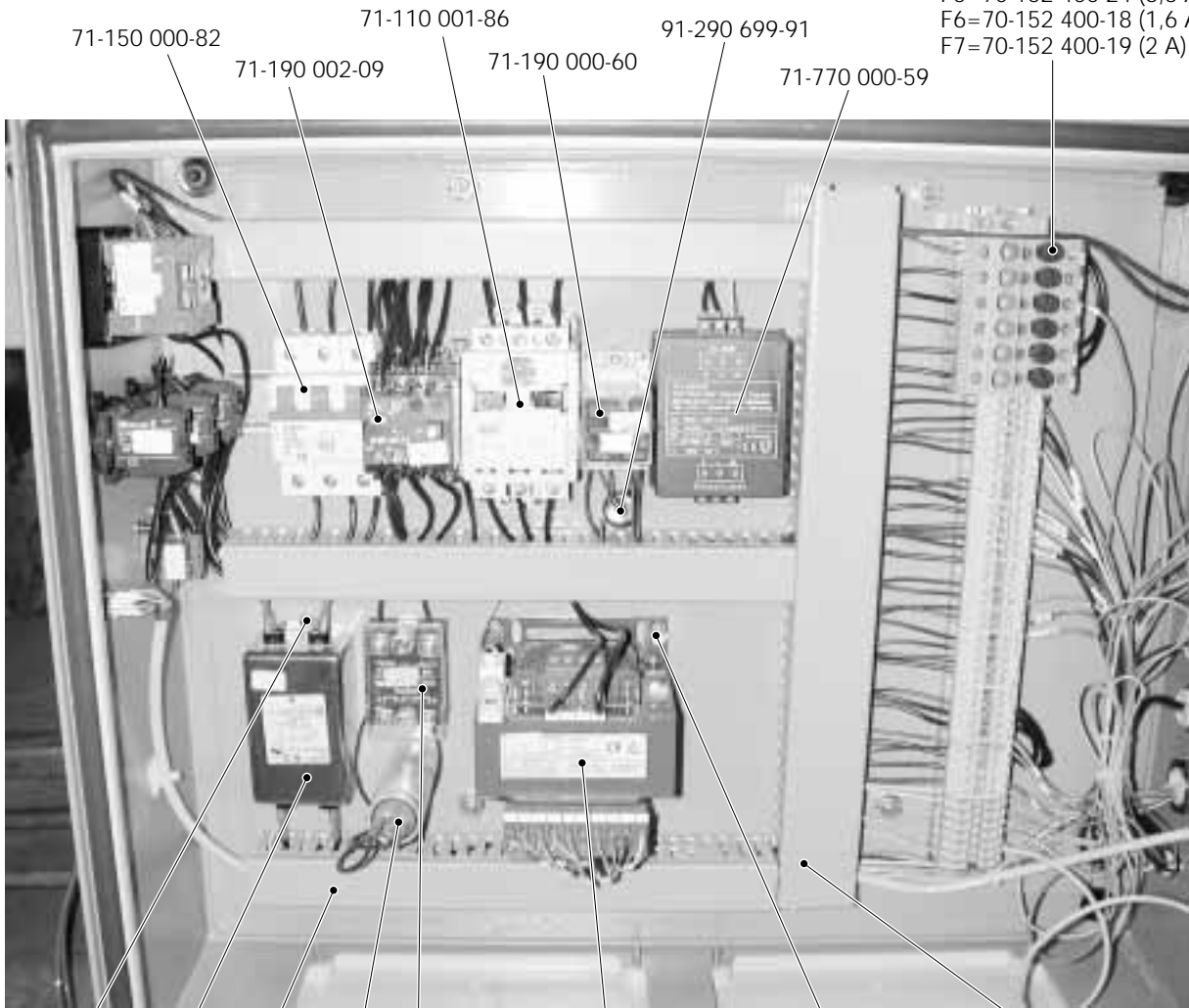
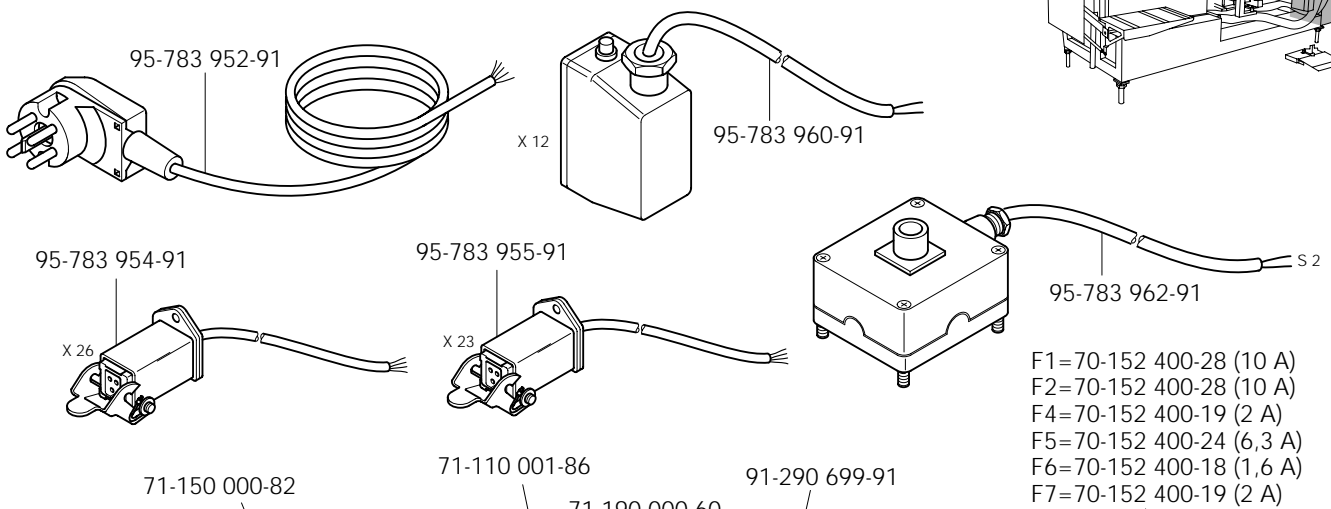
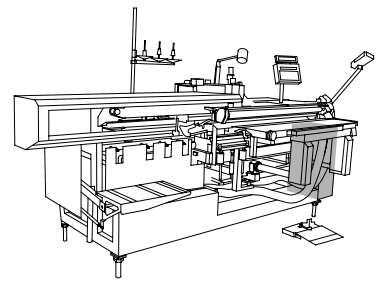

Anschluß siehe Seite 15-12
 For connection see page 15-12
 Raccord, cf. page 15-12
 Para la conexión, véase la pág. 15-12

Anschluß siehe Seite 15-12
 For connection see page 15-12
 Raccord, cf. page 15-12
 Para la conexión, véase la pág. 15-12

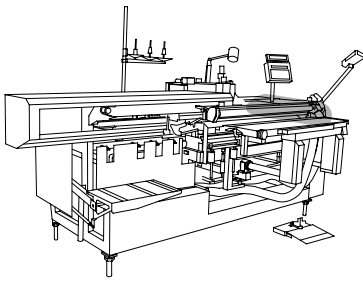

Verteiler für Saugeinrichtung
 Distributor for vacuum system
 Distributeur de dispositif d'aspiration
 Distribuidor para dispositivo de aspiración

PFAFF 3519-3/12

15.02

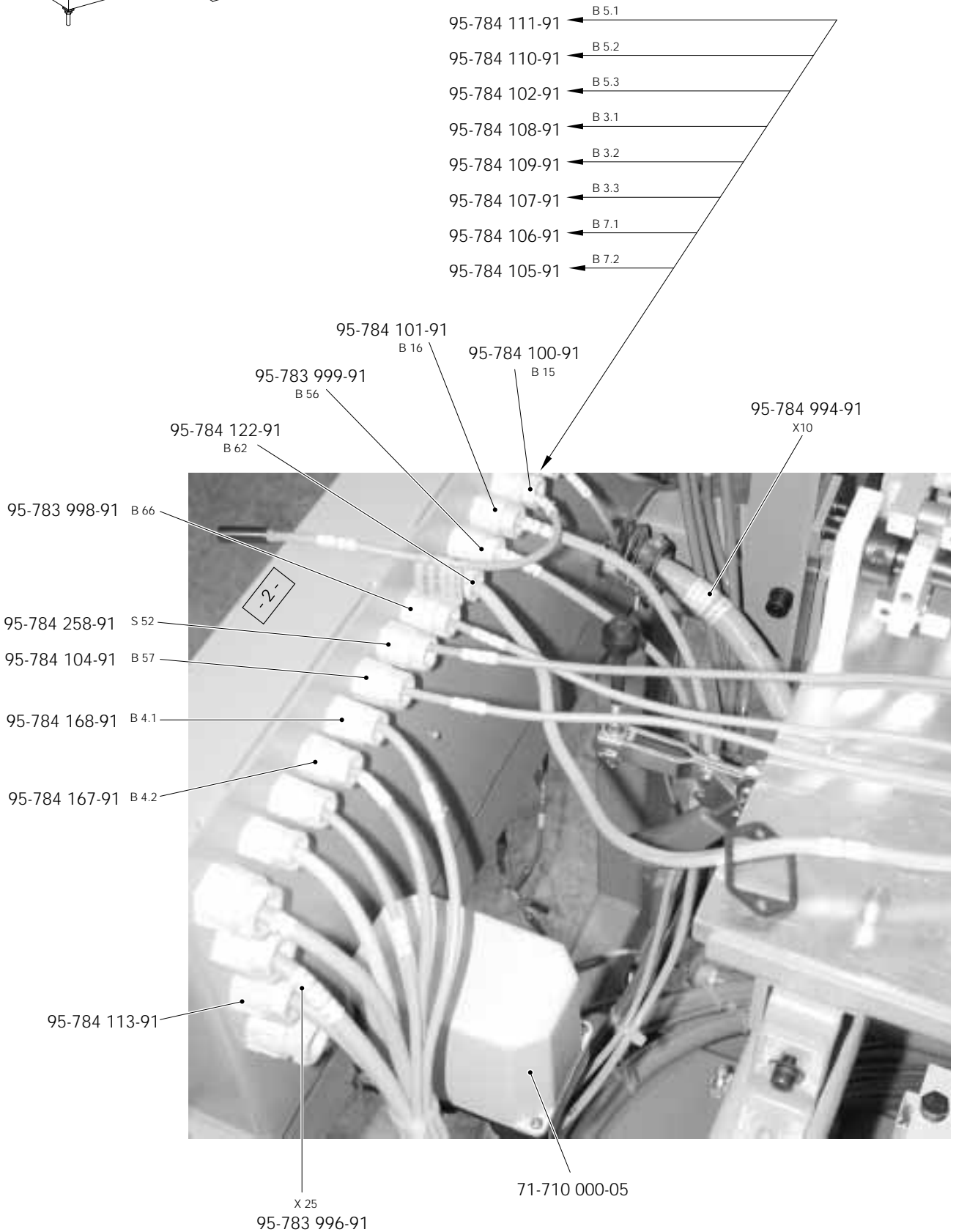

15.02

Verteiler für Saugeinrichtung
Distributor for vacuum system
Distributeur de dispositif d'aspiration
Distribuidor para dispositivo de aspiración PFAFF 3519-3/12

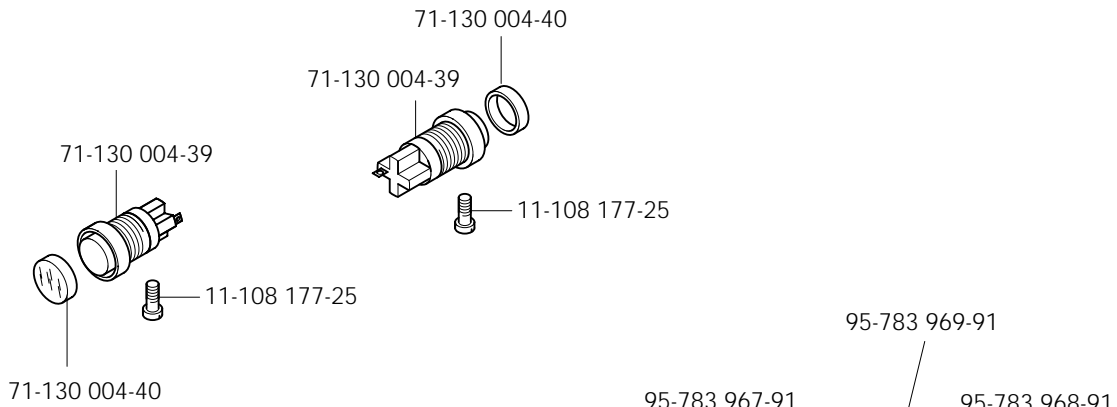
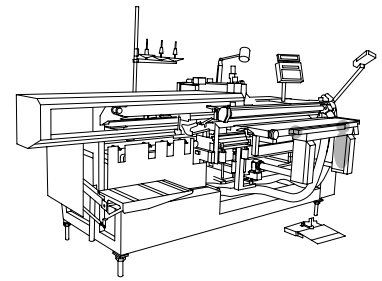

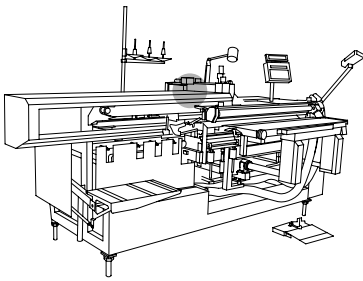

Verteiler für Saugeinrichtung
 Distributor for vacuum system
 Distributeur de dispositif d'aspiration
 Distribuidor para dispositivo de aspiración

PFAFF 3519-3/12

15.02

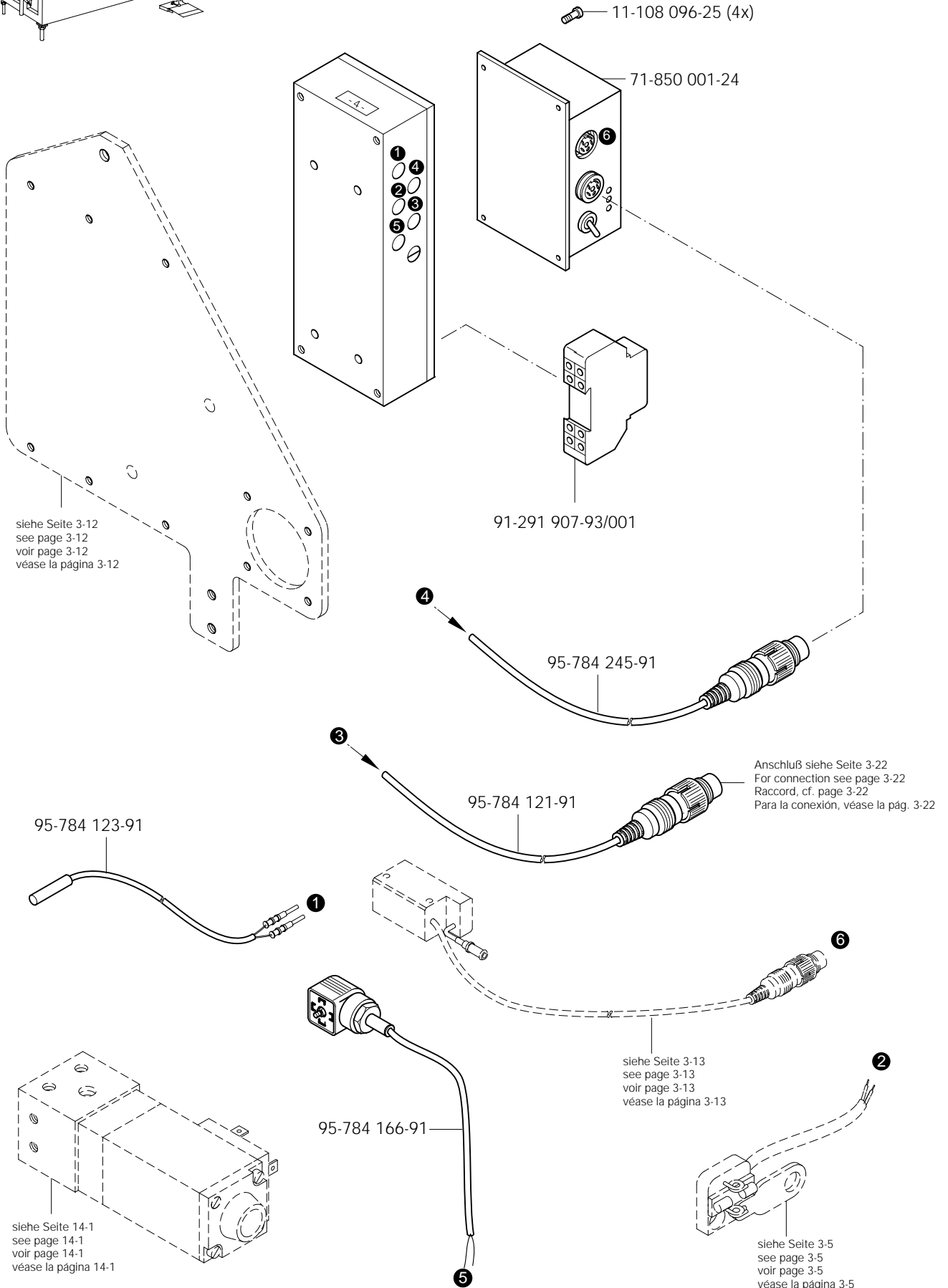

15.02

Verteiler für Saugeinrichtung
Distributor for vacuum system
Distributeur de dispositif d'aspiration
Distribuidor para dispositivo de aspiración PFAFF 3519-3/12

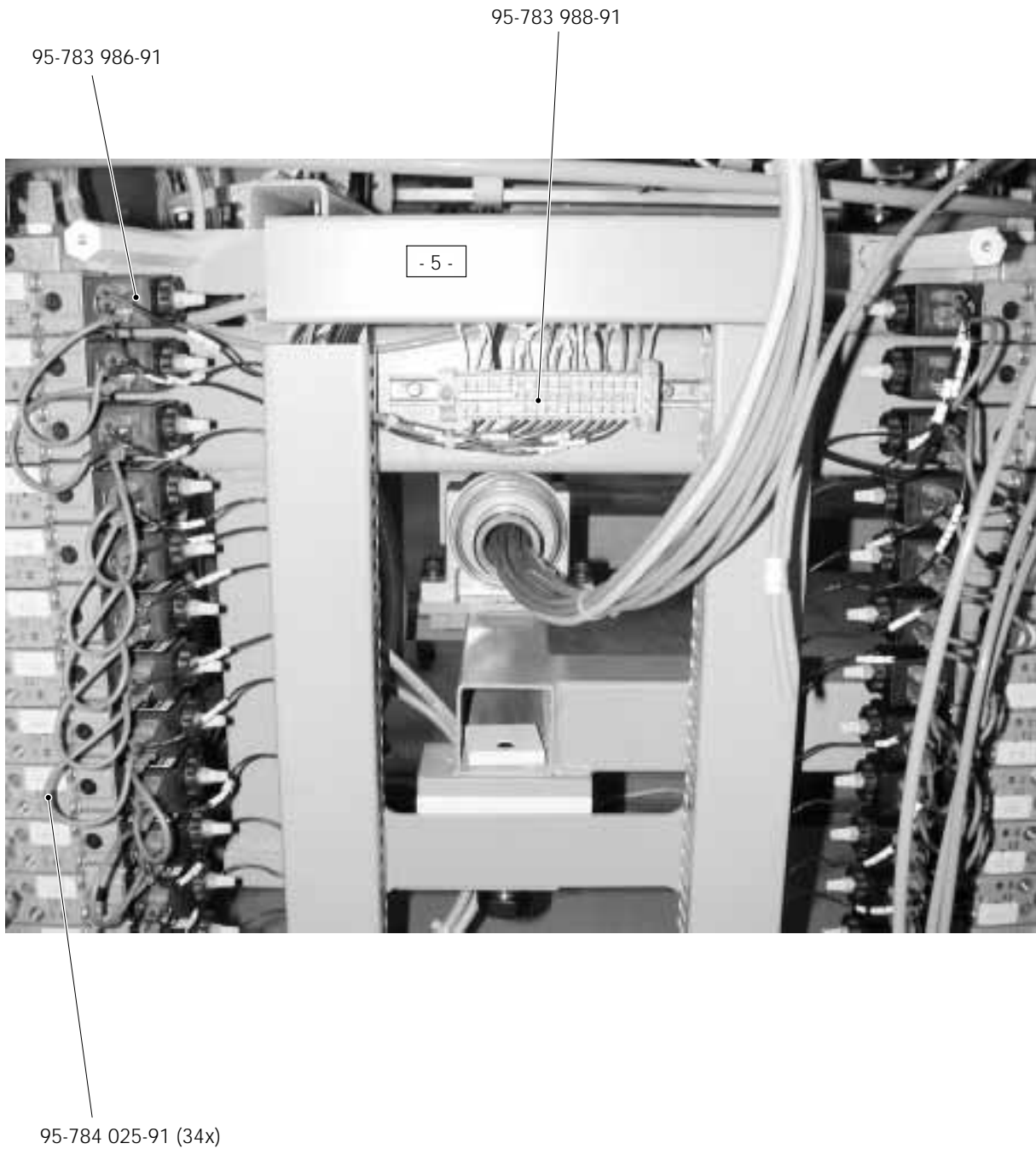
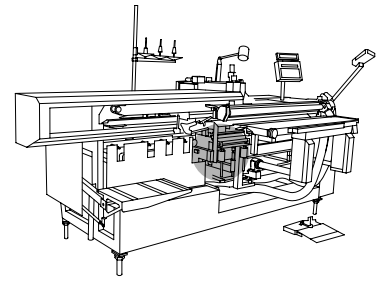

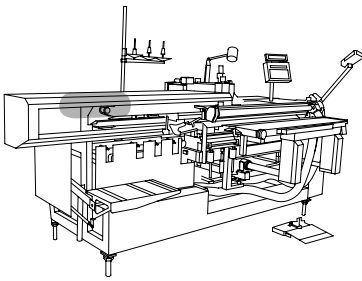

Verteiler für Saugeinrichtung
 Distributor for vacuum system
 Distributeur de dispositif d'aspiration
 Distribuidor para dispositivo de aspiración

PFAFF 3519-3/12

15.02

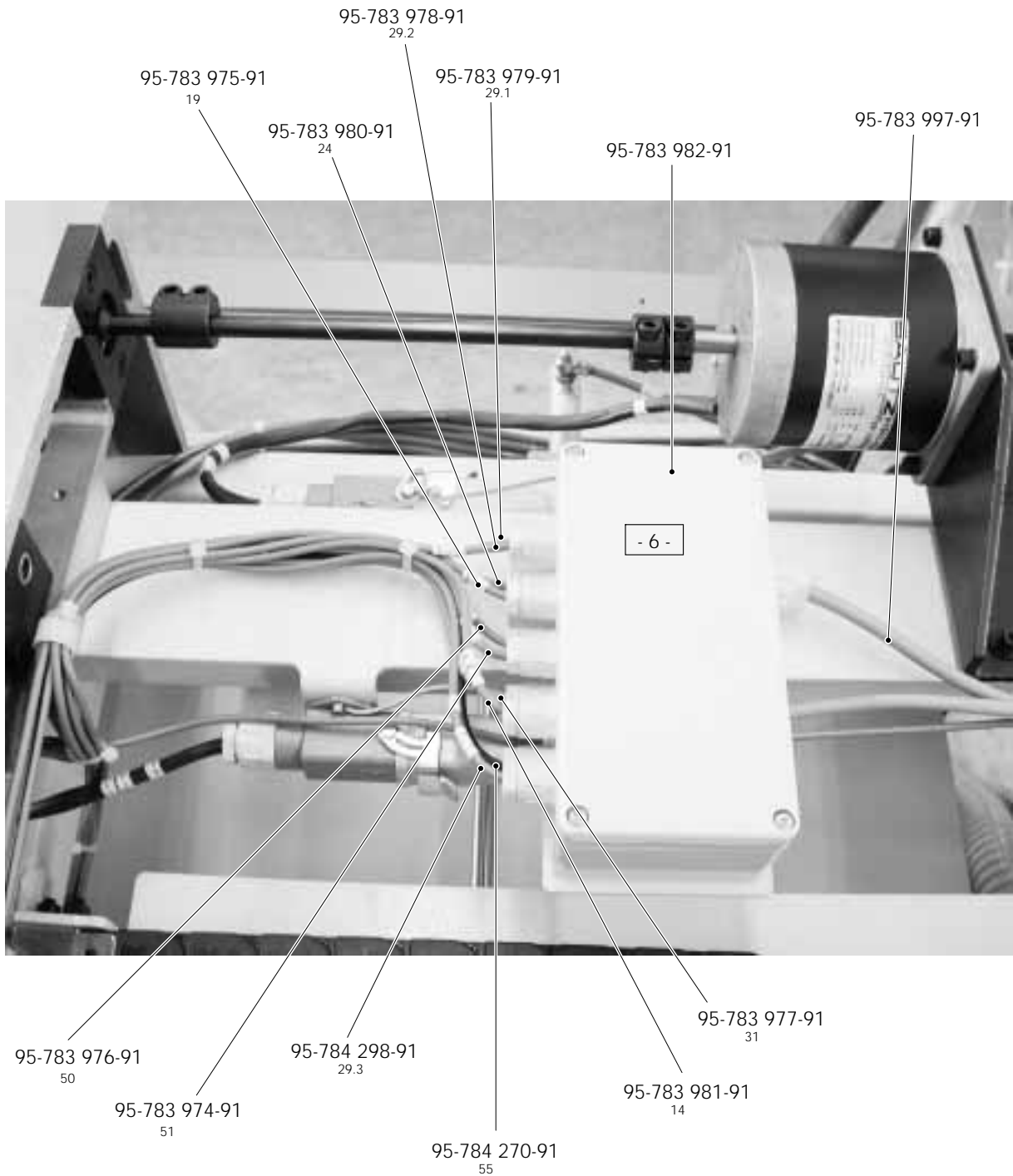

15.03

Steuergerät
Control device
Boîte de commande
Caja de mandos

PFAFF 3519-3/12

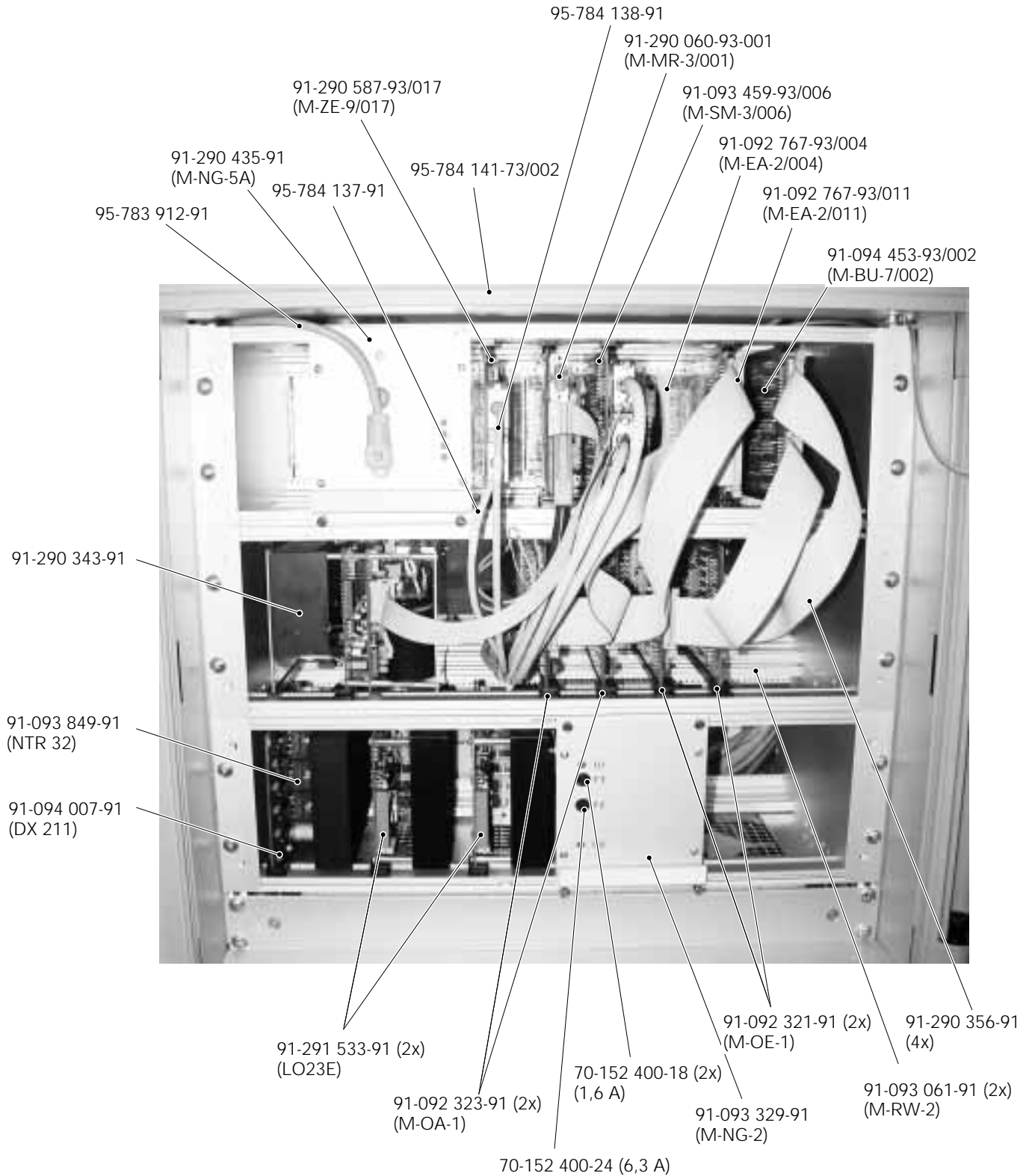
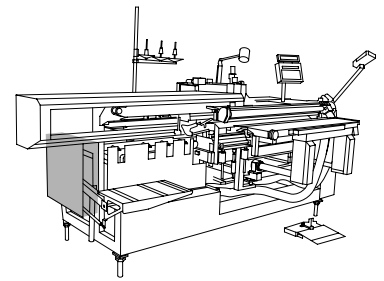

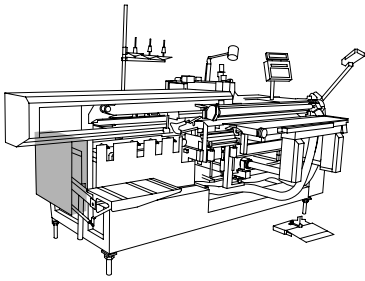

Steuergerät
Control device
Boîte de commande
Caja de mandos

PFAFF 3519-3/12

15.03

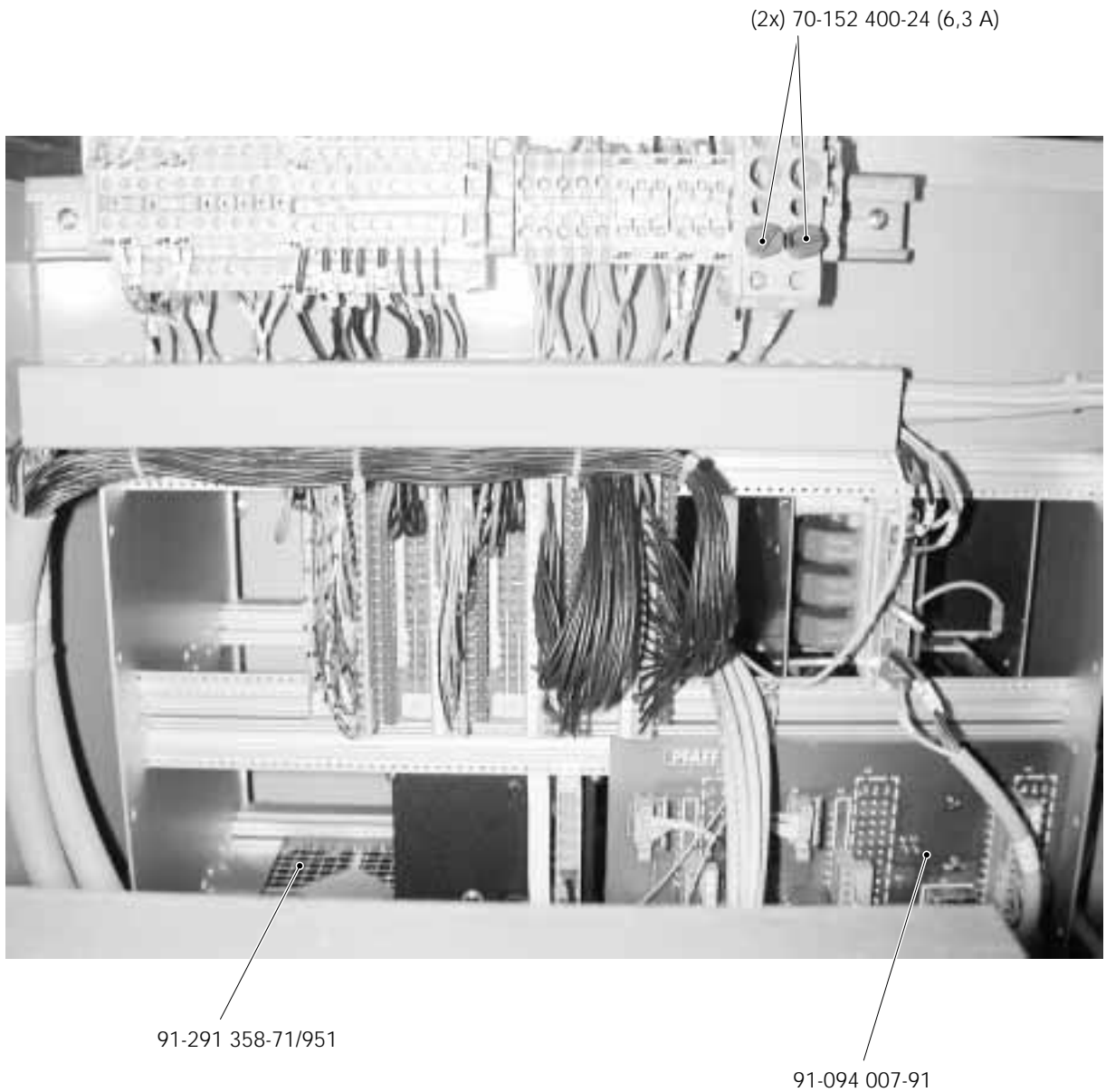

15.03

Steuergerät
Control device
Boîte de commande
Caja de mandos

PFAFF 3519-3/12

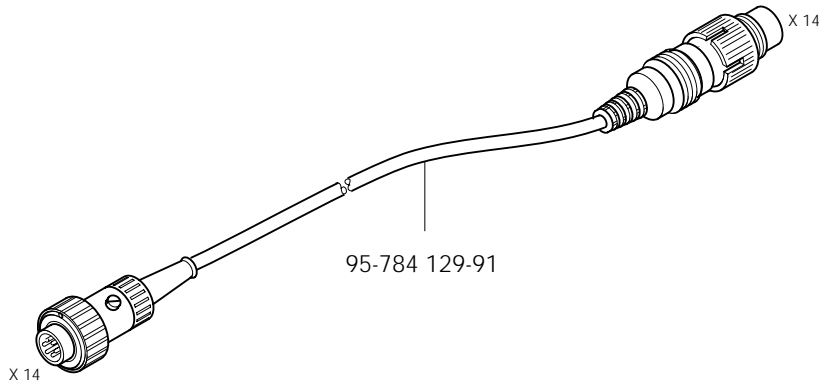
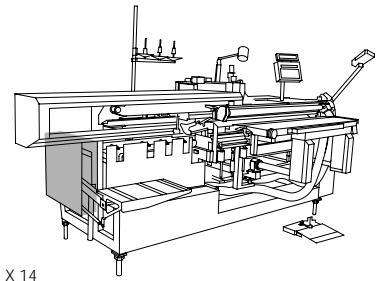

95-784 140-71/895

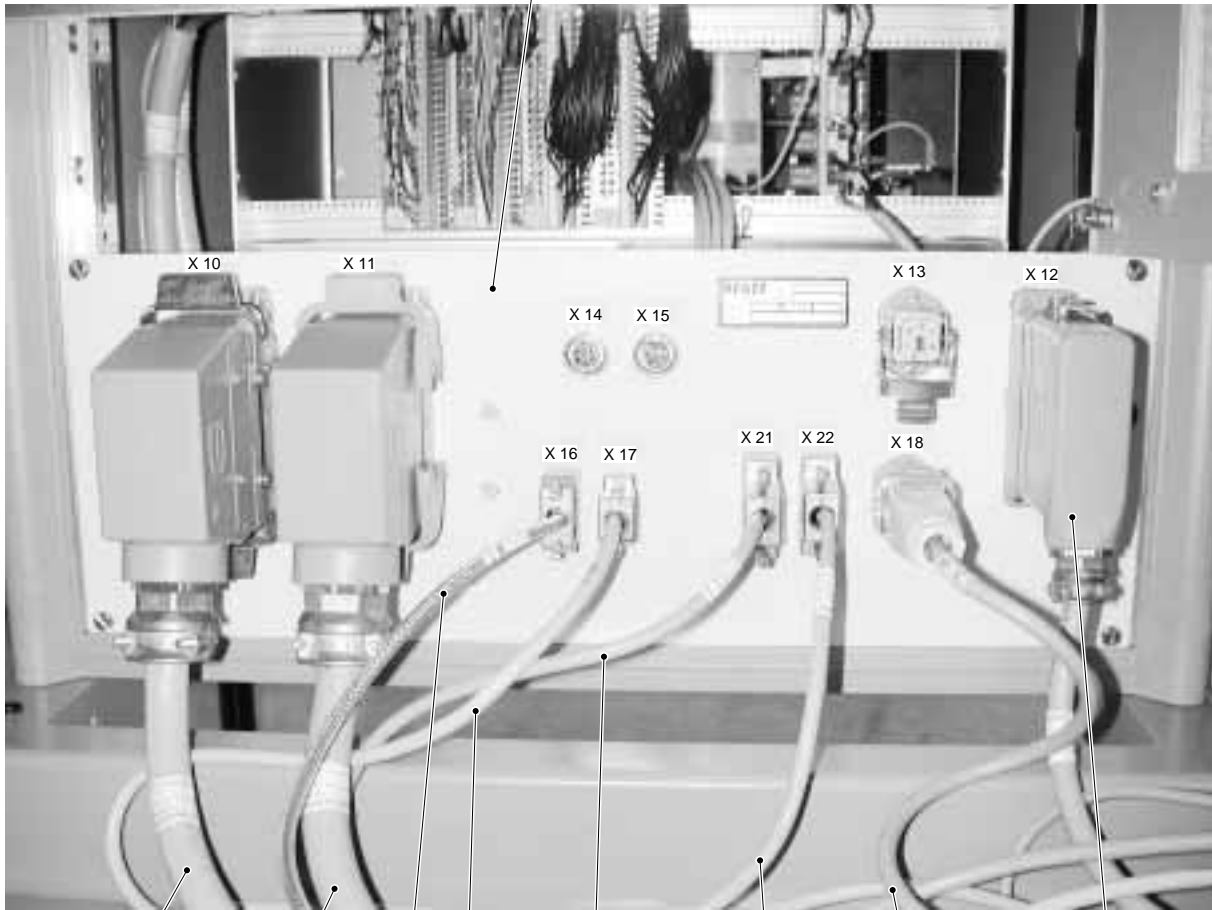

95-783 994-91

95-784 120-91

95-784 133-91

95-783 966-91

95-784 130-91

95-784 131-91

95-783 951-91

95-783 960-91

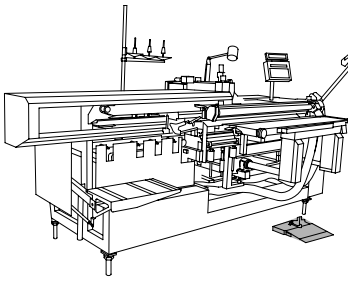

Fußtaster mit Leitung
 Foot control with cord
 Interrupteur au pied, avec câble
 Interruptor de pie, con cable

PFAFF 3519-3/12

15.04

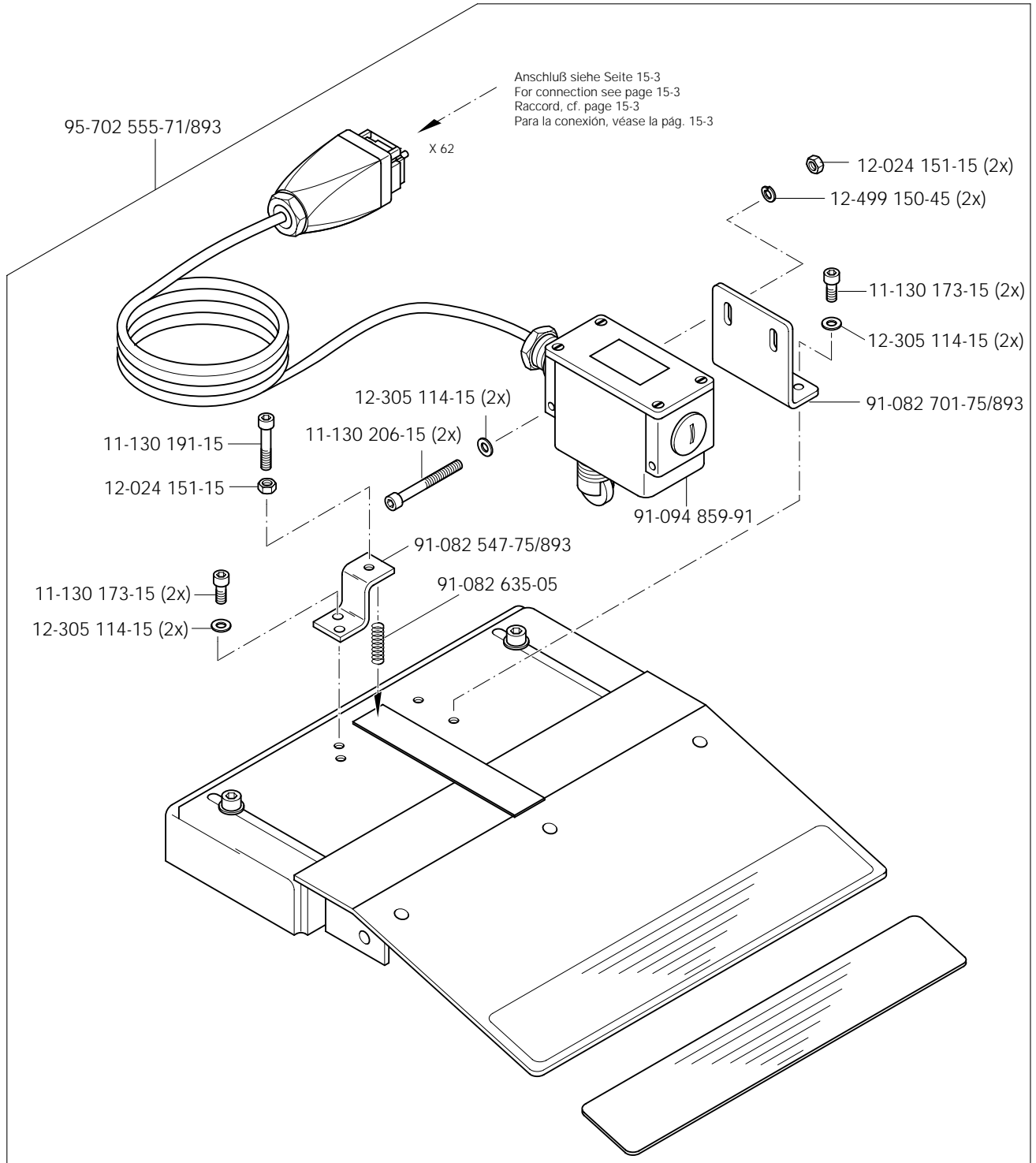

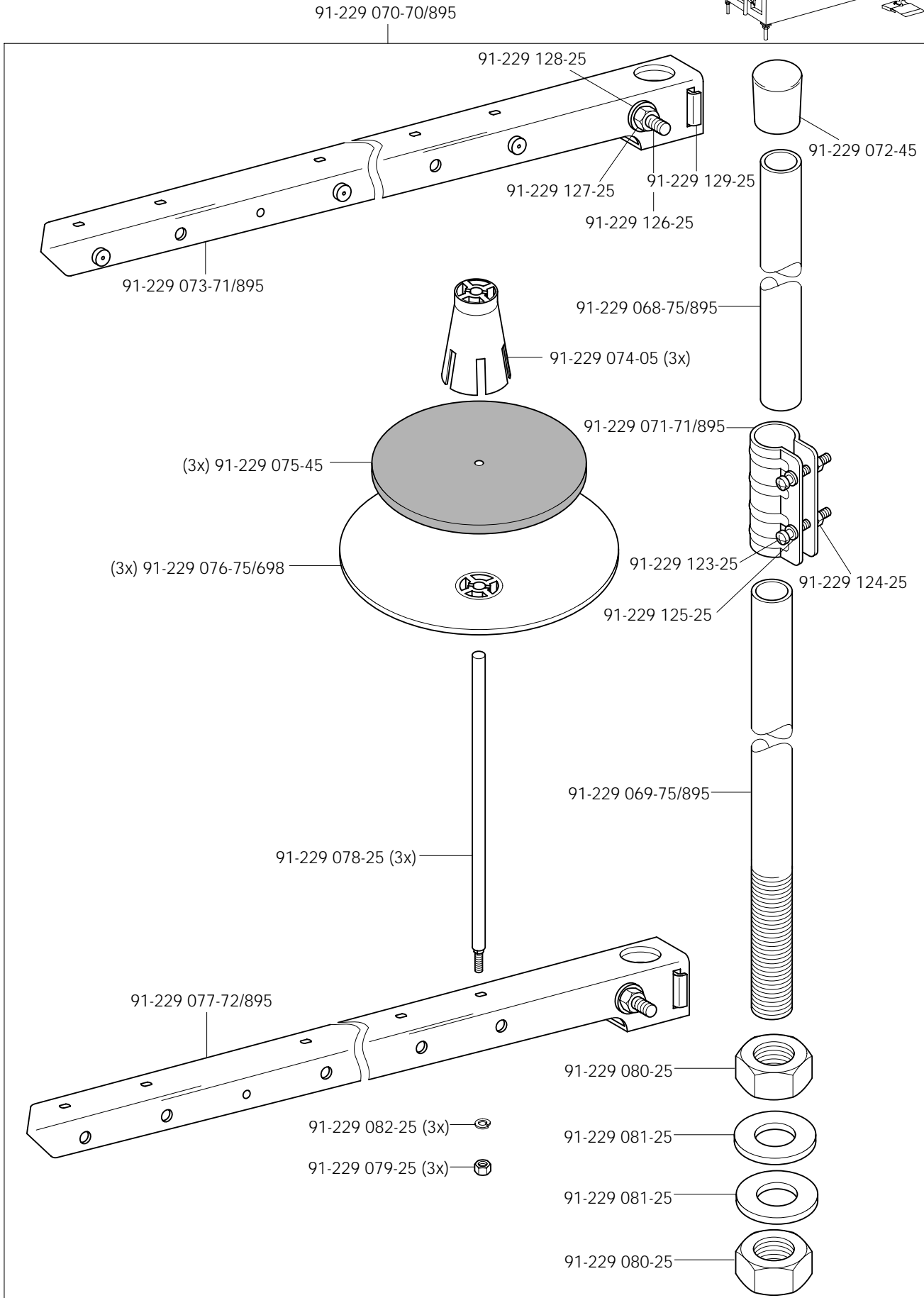
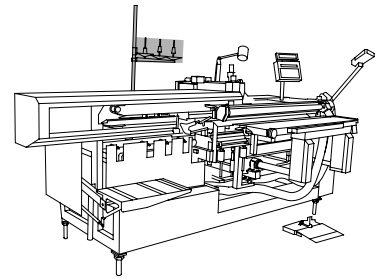

61-111 642-19

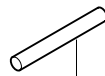
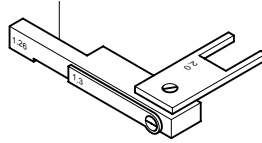

13-030 341-05

Öl Oil Huile Aceite	Mittelpunkts-Viskosität bei: Mean viscosity at: Viscosité moyenne à: Viscosidad media a:		Dichte bei: Density of: Densité à: Densidad a:		Bestellnummer für Behälter mit: Part number for can with: Numéro de commande pour récipients avec: Número de pedido para recipientes con:		
	°C	mm ² /s	°C	g/cm ³ (g/ml)	1 Liter 1 Litre 1 Litro	5 Liter 5 Litre 5 Litros	10 Liter 10 Litre 10 Litros
28-011 201-05	40	10,0	15	0,847	91-027 975-91	91-027 976-91	91-027 977-91
28-011 20 1-44	40	22,0	15	0,865	91-129 917-91	91-129 919-91	91-129 920-91
28-011 202-17 (Fadenschmiermittel) (Thread lubricant) (Agents de lubrification de fil) (Lubricantes del hilo)	40	5,8	21	0,810	91-129 941-91		

Fett Grease Graisse Grasa	Penetration Penetration Pénétration Penetración	Tropfpunkt Drip-point Point de suintement Punto de goteo	Bestellnummer für Behälter mit: Part number for can with: Numéro de commande pour récipients avec: Número de pedido para recipientes con:		
			mm/10	°C	0,25 kg
28-011 202-05					28-011 202-05
28-011 202-43	375-405	150			28-011 202-43
28-011 202-47	220-250	185			28-011 202-47

Reinigungsmittel Cleansing agent Agents de nettoyage Limpiadores	Bestellnummer für Behälter mit: Part number for can with: Numéro de commande pour récipients avec: Número de pedido para recipientes con:		
	240 ml		
Isopropyl-Alkohol	95-665 735-91		

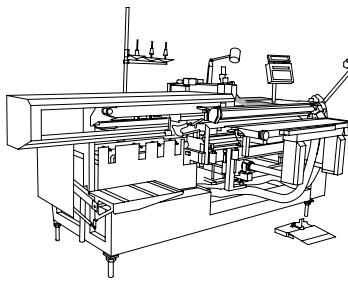

Zuführeinrichtung
Feed unit
Dispositif d'alimentation
Alimentador

PFAFF 3519-3/12

19.01

Anschluß siehe Seite 14-3
For connection see page 14-3
Raccord, cf. page 14-3
Para la conexión, véase la pág.14-3

86



Anschluß siehe Seite 14-4
For connection see page 14-4
Raccord, cf. page 14-4
Para la conexión, véase la pág.14-4

81

82

99-137 082-91

95-742 450-01

95-742 452-71/895

95-742 432-15

95-742 411-75/895 (2x)

95-742 405-71/895

95-742 446-01

91-700 113-25

95-742 445-01

95-742 436-71/895

95-742 451-01

95-742 447-01

99-134 957-91

18-378 008-91

95-742 401-25

12-703 161-12

95-742 455-01

83

12-024 191-15

12-335 191-15 (2x)

12-499 190-45

99-135 233-91 (2x)

95-742 417-15

Anschluß siehe Seite 14-4
For connection see page 14-4
Raccord, cf. page 14-4
Para la conexión, véase la pág.14-4

95-742 437-71/895

95-742 435-75/895

95-742 429-71/895 (2x)

12-305 224-15

95-742 402-71/895

99-136 470-95

12-703 212-11

95-742 421-15

19.01

Zuführeinrichtung
Feed unit
Dispositif d'alimentation
Alimentador

PFAFF 3519-3/12

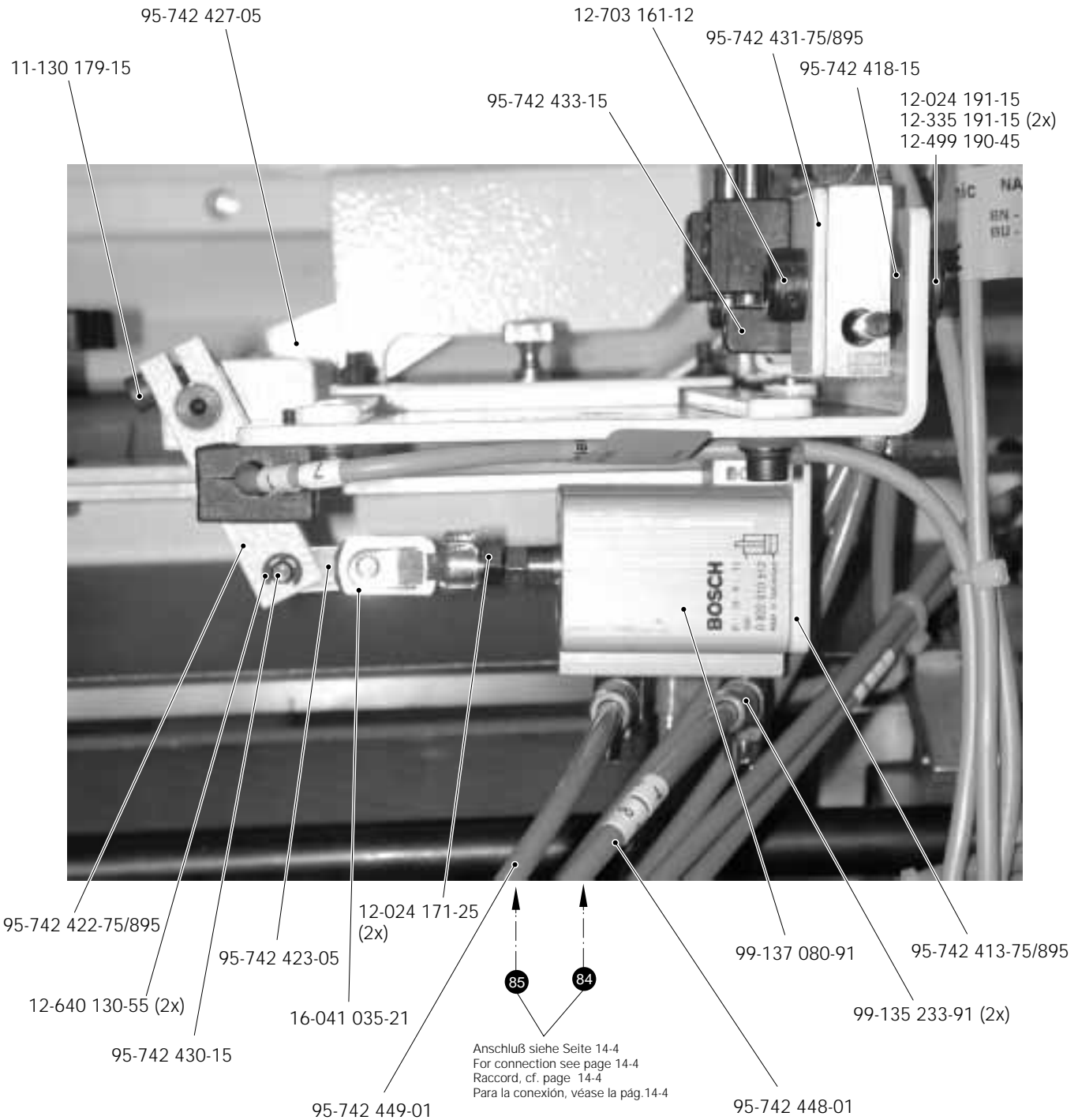
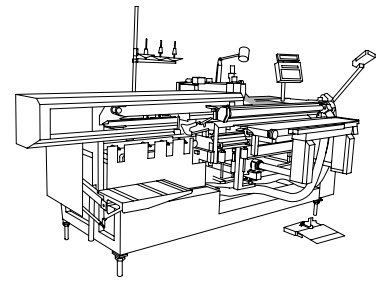

No.	Seite Page Pages Página	No.	Seite Page Pages Página	No.	Seite Page Pages Página	No.	Seite Page Pages Página
11-032 384-15	11 - 8	11-130 110-15	9 - 2, 9 - 4	11-130 305-15	11 - 5	11-225 902-15	3 - 23
11-032 915-15	7 - 6	11-130 170-15	3 - 14, 3 - 15, 11 - 3, 11 - 9	11-130 311-15	11 - 3	11-250 084-25	3 - 9
11-039 291-15	11 - 1	11-130 173-15	3 - 6, 3 - 12, 3 - 22, 11 - 4, 15 - 13	11-130 326-15	6 - 5	11-250 193-25	3 - 10
11-039 306-15	11 - 5	11-130 176-15	3 - 17, 6 - 4, 7 - 3, 7 - 5	11-130 332-15	12 - 8	11-305 239-15	3 - 22, 8 - 1
11-039 312-15	11 - 1	11-130 179-15	5 - 4, 6 - 1, 6 - 2, 6 - 3, 7 - 3, 8 - 2, 9 - 2, 9 - 4, 11 - 7, 12 - 1, 19 - 2	11-130 365-15	8 - 2, 8 - 3, 8 - 5	11-305 248-15	3 - 21
11-039 318-15	11 - 1			11-130 371-15	7 - 6	11-305 299-15	3 - 7
11-039 453-15	3 - 1			11-130 377-15	3 - 23, 8 - 2, 11 - 3	11-314 946-15	3 - 5
11-039 926-05	6 - 2	11-130 185-15	5 - 1, 9 - 1, 5 - 4, 9 - 4, 9 - 5, 11 - 9, 12 - 5	11-130 401-15	7 - 2	11-314 964-15	3 - 14
11-105 098-15	11 - 8	11-130 191-15	4 - 1, 5 - 2, 5 - 4, 6 - 1, 7 - 5, 15 - 13	11-130 906-15	10 - 1	11-317 278-15	3 - 17, 15 - 1
11-106 916-15	14 - 7, 14 - 9			11-132 226-15	6 - 2	11-317 949-15	3 - 22
11-108 009-25	3 - 16	11-130 197-15	5 - 4, 9 - 1, 14 - 5, 14 - 8, 14 - 9	11-132 232-15	12 - 3	11-330 166-15	3 - 22
11-108 084-15	3 - 16	11-130 203-15	12 - 2	11-132 286-15	11 - 5	11-330 169-15	3 - 23, 6 - 5
11-108 087-15	3 - 16	11-130 206-15	3 - 12, 15 - 13	11-132 292-15	3 - 14	11-330 217-15	5 - 2, 5 - 4, 10 - 1
11-108 096-15	6 - 3, 6 - 4, 7 - 3, 7 - 5	11-130 224-15	3 - 3, 3 - 6, 3 - 21, 3 - 22, 4 - 1, 11 - 5, 14 - 8	11-173 174-15	11 - 6, 11 - 8	11-330 220-15	3 - 2, 3 - 4, 3 - 17
11-108 096-25	15 - 7	11-130 224-25	15 - 4	11-173 174-25	3 - 5	11-330 277-15	3 - 16
11-108 108-15	3 - 5	11-130 227-15	3 - 2, 3 - 21, 5 - 1, 11 - 2, 11 - 3, 11 - 4, 11 - 7	11-173 288-25	15 - 1	11-330 280-15	3 - 4
11-108 168-25	15 - 1	11-130 233-15	3 - 11, 8 - 1, 8 - 2, 10 - 1	11-174 086-15	3 - 10	11-330 349-15	7 - 3
11-108 171-15	3 - 15	11-130 239-15	3 - 22, 6 - 2, 8 - 1, 9 - 1, 12 - 2	11-174 173-15	3 - 4	11-330 952-15	3 - 2, 3 - 9, 3 - 10, 3 - 13, 3 - 21
11-108 173-05	15 - 3	11-130 245-15	3 - 22, 9 - 2	11-174 176-25	3 - 9	11-330 955-15	3 - 10, 3 - 20 6 - 3, 6 - 4
11-108 174-25	3 - 2, 15 - 2	11-130 251-15	7 - 6, 12 - 1	11-174 224-15	3 - 3	11-330 960-15	3 - 11
11-108 177-15	3 - 1, 3 - 4	11-130 254-15	12 - 1	11-174 914-15	3 - 22	11-330 964-15	3 - 17
11-108 177-25	15 - 6	11-130 257-15	3 - 12, 14 - 2	11-178 166-15	6 - 4	11-330 964-15	3 - 17
11-108 222-15	3 - 16, 3 - 20, 3 - 22	11-130 284-15	3 - 13, 3 - 18, 11 - 9, 14 - 7	11-178 166-25	15 - 4	11-335 085-15	3 - 16
11-108 222-25	3 - 1	11-130 287-15	3 - 1, 3 - 12, 4 - 1, 8 - 2, 8 - 3, 8 - 5, 10 - 1	11-180 169-25	3 - 11	11-335 169-15	12 - 5
11-108 225-15	3 - 7, 3 - 20	11-130 293-15	3 - 11, 8 - 1, 8 - 5, 11 - 1, 11 - 2, 11 - 3, 11 - 4	11-186 934-25	3 - 2	11-335 902-15	3 - 8, 3 - 10, 3 - 11, 3 - 17
11-108 237-15	3 - 1	11-130 299-15	3 - 1, 5 - 3, 7 - 6, 8 - 2, 8 - 3, 8 - 4, 11 - 5	11-210 048-25	3 - 13	11-341 169-15	5 - 1, 5 - 4
11-108 285-25	4 - 1			11-210 048-25	3 - 13	11-341 220-15	3 - 5
11-108 846-15	3 - 17			11-210 168-25	3 - 5, 3 - 9	11-341 277-15	3 - 19
11-108 870-25	3 - 22			11-210 174-25	15 - 3	11-341 901-15	3 - 8, 3 - 16, 3 - 18
11-130 092-15	3 - 22			11-210 265-15	3 - 11	11-341 902-15	3 - 8, 3 - 10, 3 - 17, 3 - 20
11-130 095-15	6 - 1			11-225 232-15	3 - 2, 3 - 6, 11 - 5	11-341 904-15	3 - 14
11-130 097-15	3 - 2			11-225 238-15	11 - 7	11-343 901-15	3 - 12
11-130 101-15	7 - 1, 12 - 2, 12 - 3, 12 - 4			11-225 292-15	3 - 2	11-347 301-15	12 - 2
				11-225 376-15	3 - 10	11-460 202-15	15 - 3

No.	Seite Page Pages Página	No.	Seite Page Pages Página	No.	Seite Page Pages Página	No.	Seite Page Pages Página
12-005 154-25	3 - 2, 6 - 5	12-305 174-15	3 - 11, 5 - 3, 8 - 1, 8 - 2,	12-610 250-45	3 - 10	13-052 049-55	3 - 4
12-005 175-15	8 - 1, 9 - 1, 12 - 1, 12 - 2, 13 - 2		8 - 3, 8 - 4, 8 - 5, 11 - 1, 11 - 5	12-610 370-45	6 - 4, 9 - 2	13-052 088-55	3 - 17
12-005 195-15	3 - 12, 8 - 2, 8 - 3, 11 - 1, 11 - 3, 11 - 7	12-305 174-25	15 - 1	12-618 120-45	3 - 22	13-052 248-15	3 - 23
12-005 198-15	11 - 3	12-305 224-15	3 - 1, 8 - 2, 8 - 3, 8 - 5, 19 - 1	12-624 170-45	3 - 22	13-052 256-15	3 - 7
12-005 215-15	3 - 1, 11 - 8	12-305 264-15	15 - 1	12-624 200-45	3 - 6	13-063 193-05	3 - 16
12-024 121-15	6 - 4	12-305 314-15	3 - 7, 12 - 8	12-624 310-45	3 - 21	13-070 981-05	3 - 23
12-024 121-25	3 - 6	12-315 140-25	15 - 4	12-640 130-55	3 - 5, 3 - 9, 19 - 2	13-250 097-25	3 - 4
12-024 151-15	15 - 13	12-333 340-15	12 - 8	12-640 150-55	3 - 7, 3 - 14	13-540 073-05	3 - 11
12-024 151-25	15 - 3	12-335 171-15	13 - 2, 14 - 2	12-640 170-55	3 - 22	14-010 570-01	3 - 16
12-024 171-15	3 - 10, 3 - 14, 3 - 18, 3 - 21, 3 - 22, 6 - 4, 12 - 3	12-335 191-15	14 - 7, 19 - 1, 19 - 2	12-640 250-55	3 - 19	14-012 215-01	6 - 1
12-024 171-25	3 - 2, 4 - 1, 6 - 2, 8 - 1, 9 - 4, 10 - 1, 19 - 2	12-349 901-05	3 - 16	12-660 250-45	6 - 3, 6 - 4	14-012 903-01	6 - 4
12-024 172-15	3 - 10, 3 - 18	12-499 120-45	3 - 2, 7 - 1, 9 - 2, 11 - 8	12-660 320-45	6 - 4	14-015 624-91	3 - 17
12-024 191-15	3 - 7, 3 - 14, 5 - 1, 5 - 3, 11 - 1, 11 - 9, 12 - 8, 19 - 1, 19 - 2	12-499 150-45	4 - 1, 6 - 1, 6 - 2, 6 - 3, 6 - 4, 6 - 5, 9 - 1, 9 - 5, 15 - 13	12-660 390-45	3 - 16	14-016 080-01	3 - 16
12-024 191-25	3 - 9	12-499 170-45	3 - 2, 3 - 6, 6 - 2, 10 - 1, 12 - 2	12-703 161-12	19 - 1, 19 - 2	14-016 126-01	11 - 3, 11 - 5, 11 - 9
12-024 211-15	7 - 3, 9 - 3	12-499 190-45	10 - 1, 11 - 7, 11 - 9, 12 - 8, 19 - 1, 19 - 2	12-703 212-11	19 - 1	14-018 570-01	3 - 3
12-024 231-15	3 - 1, 15 - 1	12-499 210-45	3 - 23	12-710 170-12	6 - 1	14-018 624-91	3 - 17
12-024 251-15	12 - 8	12-501 150-45	5 - 1, 5 - 4, 7 - 5, 8 - 1, 9 - 4, 15 - 1	12-710 210-12	7 - 1, 12 - 5	14-018 644-91	3 - 8
12-024 962-05	15 - 3	12-501 170-45	3 - 11, 4 - 1, 5 - 1, 7 - 3, 7 - 5, 8 - 2, 9 - 1	12-710 230-12	7 - 2	14-210 050-01	6 - 3, 6 - 4
12-085 170-15	3 - 22	12-501 190-45	3 - 1, 3 - 11, 4 - 1, 5 - 3, 8 - 2, 8 - 3, 8 - 4, 8 - 5, 11 - 4, 14 - 7	12-710 250-02	12 - 7	14-246 122-01	11 - 7
12-193 191-15	11 - 3		7 - 6, 8 - 2, 8 - 3, 8 - 5	12-710 290-02	12 - 8	14-602 901-01	3 - 9
12-305 084-15	3 - 2, 7 - 1, 9 - 2, 11 - 8	12-501 210-45	15 - 1	12-710 290-02	12 - 8	14-650 243-05	3 - 2
12-305 114-15	3 - 4, 5 - 1, 6 - 1, 8 - 2, 9 - 1, 9 - 4, 9 - 5, 11 - 4, 11 - 9, 14 - 5, 15 - 13	12-505 190-45	15 - 1	13-030 209-05	5 - 4	14-731 679-05	11 - 5, 12 - 5
12-305 144-15	3 - 2, 3 - 6, 3 - 22, 4 - 1, 5 - 1, 6 - 2, 7 - 5, 8 - 1, 9 - 1, 10 - 1, 12 - 3, 14 - 8, 14 - 9	12-505 230-45	15 - 1	13-030 272-05	5 - 1, 5 - 4	14-731 694-05	5 - 4
		12-510 111-25	15 - 3	13-030 310-05	3 - 7	14-731 724-05	5 - 2
		12-518 210-45	15 - 4	13-030 341-05	17 - 1	14-731 913-05	12 - 7
		12-610 190-45	3 - 14	13-030 464-05	8 - 2	14-755 037-01	6 - 4
		12-610 200-45	3 - 17	13-030 470-05	5 - 1	14-755 056-01	11 - 8
		12-610 230-45	3 - 16, 3 - 22	13-033 091-05	3 - 2	15-032 001-45	3 - 23, 14 - 7
				13-033 190-05	3 - 16, 6 - 1	15-032 002-45	14 - 6
				13-033 199-05	3 - 2	15-032 006-45	3 - 23
				13-033 220-05	3 - 22	15-120 800-05	3 - 19
				13-033 277-05	12 - 1	15-120 924-05	3 - 17
				13-033 280-05	3 - 22	16-041 035-21	3 - 14, 9 - 4, 12 - 1, 12 - 2, 12 - 5, 19 - 2
				13-033 460-05	3 - 18		

No.	Seite Page Pages Página	No.	Seite Page Pages Página	No.	Seite Page Pages Página	No.	Seite Page Pages Página
16-041 045-21	8 - 1	26-536 301-09	3 - 4, 3 - 16	71-410 001-25	15 - 4	91-056 198-21	3 - 9
16-041 055-21	12 - 8	28-011 201-05	18 - 1	71-480 000-12	15 - 4	91-056 578-91	3 - 9
16-041 065-11	8 - 3	28-011 201-44	18 - 1	71-550 001-79	15 - 4	91-056 760-05	3 - 9
16-041 075-11	7 - 1, 9 - 3	28-011 202-05	18 - 1	71-710 000-05	15 - 5	91-059 898-05	3 - 13
16-049 020-11	3 - 10, 3 - 18	28-011 202-17	18 - 1	71-770 000-59	15 - 4	91-066 094-05	5 - 2, 5 - 4
16-049 021-11	3 - 10, 3 - 18	28-011 202-43	18 - 1	71-850 001-24	15 - 7	91-068 074-05	3 - 20
16-409 940-05	6 - 2	28-011 202-47	18 - 1	91-000 250-15	3 - 15	91-069 046-05	3 - 7
16-409 946-05	3 - 11	50-270 142-02	4 - 1, 5 - 2	91-000 390-05	3 - 15	91-069 062-45	3 - 17
17-028 358-01	5 - 1	61-111 642-19	17 - 1	91-000 407-15	3 - 13	91-069 127-05	3 - 10
17-518 010-51	14 - 6	70-152 400-18	15 - 4, 15 - 10	91-000 678-15	3 - 15	91-069 131-91	3 - 10
17-518 070-51	7 - 4	70-152 400-19	15 - 4	91-000 790-15	3 - 15	91-069 222-12	3 - 10
17-518 090-51	13 - 2	70-152 400-24	15 - 3, 15 - 4, 15 - 10, 15 - 11	91-002 065-05	3 - 5	91-069 287-05	3 - 13
17-518 100-51	13 - 2	70-152 400-28	15 - 4	91-002 134-05	3 - 15	91-069 289-05	3 - 13
18-277 001-91	12 - 7, 14 - 7	70-163 010-03	15 - 3	91-005 694-01	6 - 4	91-069 296-12	3 - 13
18-277 003-91	14 - 6	71-110 001-86	15 - 4	91-006 814-05	3 - 5	91-069 299-05	3 - 1
18-278 005-91	7 - 1	71-110 003-07	15 - 3	91-006 818-05	3 - 5	91-069 555-05	3 - 13
18-279 010-05	14 - 1	71-130 004-39	15 - 6	91-009 026-05	3 - 15	91-069 562-05	3 - 12
18-372 001-91	14 - 7	71-130 004-40	15 - 6	91-009 076-61	3 - 15	91-069 955-05	3 - 6
18-372 009-91	14 - 3	71-130 004-79	7 - 4	91-009 148-05	3 - 14	91-082 547-75/893	15 - 13
18-378 001-91	7 - 2, 7 - 4, 12 - 1, 12 - 7, 13 - 1, 14 - 1, 14 - 3, 14 - 4, 14 - 5, 14 - 7, 14 - 8, 14 - 9	71-130 004-84	15 - 3	91-010 176-05	6 - 1	91-082 635-05	15 - 13
18-378 003-91	14 - 7, 14 - 8	71-130 005-53	5 - 1, 9 - 2, 9 - 4, 11 - 4, 12 - 2, 12 - 3, 12 - 4, 12 - 5	91-020 490-15	3 - 3	91-082 701-75/893	15 - 13
18-378 004-91	14 - 6	71-130 005-89	15 - 2	91-021 201-05	19 - 1	91-086 176-75/893	14 - 7
18-378 008-91	12 - 1, 12 - 7, 19 - 1	71-150 000-82	15 - 4	91-027 975-91	18 - 1	91-087 273-71/893	3 - 10
18-378 009-91	12 - 3, 12 - 4, 14 - 8, 14 - 9	71-170 001-31	3 - 22	91-027 976-91	18 - 1	91-087 282-11	3 - 10
18-378 010-91	14 - 3, 14 - 4, 14 - 5	71-190 000-60	15 - 4	91-027 977-91	18 - 1	91-087 294-15	3 - 10
18-381 002-91	14 - 6	71-190 002-09	15 - 4	91-029 521-05	3 - 20	91-087 295-95	3 - 10
25-161 801-49	3 - 4, 3 - 16	71-190 002-52	15 - 4	91-034 450-21	4 - 1	91-087 296-75/895	3 - 10
25-161 801-59	3 - 16	71-210 001-25	3 - 22	91-034 451-75/699	4 - 1	91-087 306-75/893	3 - 10
25-161 805-04	14 - 6	71-250 002-52	15 - 3	91-034 489-21	4 - 1	91-087 906-15	3 - 10
25-308 820-30	3 - 13, 3 - 14	71-370 001-08	15 - 3	91-050 596-05	3 - 22	91-087 907-15	3 - 10
25-308 820-40	3 - 23, 14 - 1	71-370 001-31	3 - 22, 7 - 3, 7 - 5	91-056 192-25	3 - 9	91-087 928-05	3 - 10
		71-370 001-35	15 - 2	91-056 193-25	3 - 9	91-087 961-71/951	3 - 23
				91-056 197-91	3 - 9	91-088 197-75/698	3 - 10

No.	Seite Page Pages Página	No.	Seite Page Pages Página	No.	Seite Page Pages Página	No.	Seite Page Pages Página
91-088 915-15	3 - 10	91-129 919-91	18 - 1	91-168 347-05	3 - 19	91-171 037-91	3 - 5
91-088 916-15	3 - 10	91-129 920-91	18 - 1	91-168 385-05	3 - 19	91-171 038-05	3 - 5
91-088 917-15	3 - 10	91-129 941-91	18 - 1	91-168 415-15	3 - 22	91-171 039-05	3 - 5
91-092 321-91	15 - 10	91-140 945-05	3 - 15	91-168 480-15	3 - 11	91-171 040-05	3 - 5
91-092 323-91	15 - 10	91-150 504-04/002	3 - 13	91-168 496-92	3 - 20	91-171 042-05	3 - 9
91-092 767-93/004	15 - 10	91-154 663-03	3 - 2	91-168 833-05	3 - 19, 3 - 21	91-171 049-05	3 - 9
91-092 767-93/011	15 - 10	91-165 505-05	3 - 16	91-168 858-12	3 - 21	91-171 074-05	3 - 3
91-093 061-91	15 - 10	91-165 605-05	3 - 5	91-168 901-92	3 - 18	91-171 098-93	3 - 8
91-093 329-91	15 - 10	91-165 609-05	3 - 6	91-168 906-02	3 - 22	91-171 100-93	3 - 17
91-093 459-93/006	15 - 10	91-165 617-01	3 - 6	91-168 907-05	3 - 22	91-171 104-91	3 - 17
91-093 849-91	15 - 10	91-165 685-05	3 - 16	91-168 909-15	3 - 22	91-171 151-91	3 - 19
91-094 007-91	15 - 10, 15 - 11	91-165 745-15	3 - 16	91-168 910-05	3 - 22	91-171 158-92	3 - 20
91-094 453-93/002	15 - 10	91-165 799-41	3 - 15	91-168 917-05	3 - 22	91-171 162-91	3 - 17
91-094 859-91	15 - 13	91-165 800-91	3 - 15	91-168 918-05	3 - 22	91-171 173-92/001	3 - 16
91-095 850-91	3 - 22	91-165 821-92	3 - 21	91-168 927-15	3 - 22	91-171 176-75/770	3 - 17
91-099 904-45	3 - 22	91-165 887-91	3 - 23	91-168 934-05	3 - 22	91-171 181-05	3 - 1
91-100 143-05	3 - 6	91-166 452-21	3 - 9	91-168 934-92	3 - 22	91-171 182-15	3 - 1
91-100 270-25	7 - 5, 9 - 5	91-167 435-05	3 - 16	91-168 938-91	3 - 22	91-171 205-05	3 - 19, 3 - 21
91-100 281-25	3 - 9	91-167 553-11	3 - 22	91-168 939-12	3 - 22	91-171 283-91	3 - 7
91-100 296-25	3 - 13	91-167 556-11	3 - 22	91-169 207-15	3 - 22	91-171 337-12	3 - 21
91-100 400-15	3 - 8	91-167 559-05	3 - 22	91-169 245-91	3 - 16	91-171 435-05	3 - 19
91-106 133-05	3 - 22	91-167 560-05	3 - 22	91-169 582-05	3 - 22	91-171 465-91	3 - 20
91-106 182-05	3 - 22	91-167 590-15	3 - 1	91-170 156-12	3 - 14	91-171 467-04/002	3 - 21
91-106 401-05	3 - 22	91-167 636-05	3 - 22	91-170 929-92	3 - 10	91-171 478-91	3 - 20
91-107 663-05	12 - 1	91-167 865-92	3 - 4	91-171 008-05	3 - 3	91-171 502-91	3 - 18
91-118 099-91	3 - 9	91-168 039-05	3 - 4	91-171 009-91	3 - 3	91-171 529-15	3 - 18
91-118 681-05	3 - 9	91-168 041-05	3 - 4	91-171 010-91	3 - 3	91-171 531-91	3 - 18
91-118 683-05	3 - 9	91-168 055-91	3 - 8	91-171 012-91	3 - 8	91-171 540-91	3 - 7
91-118 685-05	3 - 9	91-168 192-25	3 - 5	91-171 018-91	3 - 4	91-171 542-91	3 - 23
91-118 893-92	3 - 18	91-168 244-04	3 - 8	91-171 019-05	3 - 4	91-171 543-05	3 - 23
91-118 940-05	3 - 9	91-168 257-91	3 - 17	91-171 029-05	3 - 4	91-171 544-12	3 - 23
91-120 175-72/895	8 - 4	91-168 258-92	3 - 17	91-171 030-01	3 - 4	91-171 785-05	3 - 16
91-129 917-91	18 - 1	91-168 341-05	3 - 20	91-171 036-05	3 - 2	91-171 797-05	3 - 16

No.	Seite Page Pages Página	No.	Seite Page Pages Página	No.	Seite Page Pages Página	No.	Seite Page Pages Página
91-171 808-05	3 - 2	91-174 253-25	3 - 2	91-174 855-05	3 - 22	91-229 082-25	16 - 1
91-171 835-91	3 - 22	91-174 257-05	3 - 10	91-174 856-05	3 - 22	91-229 123-25	16 - 1
91-171 850-91	3 - 16	91-174 275-91	3 - 4	91-174 857-11	3 - 22	91-229 124-25	16 - 1
91-171 851-05	3 - 16	91-174 279-92	3 - 2	91-174 860-05	3 - 22	91-229 125-25	16 - 1
91-171 853-15	3 - 16	91-174 293-05	3 - 21	91-174 861-05	3 - 22	91-229 126-25	16 - 1
91-171 854-15	3 - 16	91-174 294-15	3 - 21	91-174 862-05	3 - 22	91-229 127-25	16 - 1
91-171 874-12	3 - 17	91-174 295-12	3 - 21	91-174 863-12	3 - 22	91-229 128-25	16 - 1
91-171 875-12	3 - 17	91-174 340-91	3 - 8	91-174 865-91	3 - 22	91-229 129-25	16 - 1
91-171 922-91	3 - 13	91-174 344-92	3 - 8	91-174 867-91	3 - 6	91-262 020-15	3 - 15
91-171 923-15	3 - 14	91-174 348-91	3 - 8	91-174 875-05	3 - 6	91-265 052-75/895	3 - 1
91-171 925-05	3 - 14	91-174 361-01	3 - 6	91-174 879-05	3 - 9	91-265 065-05	3 - 16
91-171 926-12	3 - 14	91-174 367-01	3 - 6	91-175 557-01	3 - 6	91-265 119-91	3 - 4
91-171 928-15	3 - 14	91-174 371-15	3 - 10	91-175 690-05	3 - 15	91-265 120-91	3 - 4
91-171 929-01	3 - 14	91-174 388-71/893	3 - 1	91-175 717-15	3 - 23	91-265 206-91	3 - 16
91-171 932-05	3 - 14	91-174 396-05	3 - 5	91-175 762-05	3 - 6	91-265 207-91	3 - 16
91-171 933-05	3 - 14	91-174 424-15	3 - 23	91-175 785-05	3 - 15	91-265 208-05	3 - 16
91-171 934-91	3 - 14	91-174 438-25	3 - 5	91-175 838-15	3 - 16	91-265 209-91	3 - 16
91-171 936-12	3 - 14	91-174 439-25	3 - 5	91-175 897-16	3 - 13	91-265 210-05	3 - 16
91-171 938-05	3 - 14	91-174 440-25	3 - 5	91-186 493-05	3 - 15	91-265 212-91	3 - 15
91-171 939-05	3 - 17	91-174 441-05	3 - 5	91-229 068-75/895	16 - 1	91-265 220-12	3 - 22
91-171 948-92	3 - 7	91-174 454-91	3 - 5	91-229 069-75/895	16 - 1	91-266 310-05	3 - 15
91-171 949-05	3 - 7	91-174 455-15	3 - 5	91-229 070-70/895	16 - 1	91-266 397-01	3 - 9
91-171 951-05	3 - 1	91-174 474-25	3 - 1	91-229 071-71/895	16 - 1	91-268 076-15	3 - 16
91-171 953-11	3 - 18	91-174 501-15	3 - 1	91-229 072-45	16 - 1	91-290 060-93/001	15 - 10
91-171 954-15	3 - 18	91-174 507-05	3 - 15	91-229 073-71/895	16 - 1	91-290 343-91	15 - 10
91-171 971-05	3 - 3	91-174 582-05	3 - 22	91-229 074-05	16 - 1	91-290 356-91	15 - 10
91-172 676-05	3 - 21	91-174 680-91	3 - 17	91-229 075-45	16 - 1	91-290 435-91	15 - 10
91-172 903-72/951	3 - 23	91-174 687-91	3 - 4	91-229 076-75/698	16 - 1	91-290 587-93/017	15 - 10
91-172 910-05	3 - 23	91-174 733-25	3 - 5	91-229 077-72/895	16 - 1	91-290 699-91	15 - 4
91-172 925-92	3 - 23	91-174 740-11	3 - 18	91-229 078-25	16 - 1	91-290 704-71/699	15 - 2
91-174 016-05	3 - 4	91-174 762-05	3 - 1	91-229 079-25	16 - 1	91-291 032-91	15 - 1
91-174 059-05	3 - 6	91-174 783-05	3 - 9	91-229 080-25	16 - 1	91-291 358-71/951	15 - 11
91-174 142-11	3 - 7	91-174 851-05	3 - 6	91-229 081-25	16 - 1	91-291 533-91	15 - 10

No.	Seite Page Pages Página	No.	Seite Page Pages Página	No.	Seite Page Pages Página	No.	Seite Page Pages Página
91-291 907-93/001	15 - 7	95-742 431-75/895	19 - 2	95-742 721-15	11 - 9	95-742 968-71/951	8 - 2
91-700 113-25	19 - 1	95-742 432-15	19 - 1	95-742 722-15	11 - 3, 11 - 5	95-742 969-15	8 - 2
91-700 262-25	11 - 9	95-742 433-15	19 - 2	95-742 723-05	11 - 5	95-743 045-71/893	4 - 1
91-700 335-25	3 - 5, 7 - 3, 8 - 2, 8 - 5, 12 - 4	95-742 435-75/895	19 - 1	95-742 725-71/895	11 - 9	95-743 109-71/893	4 - 1
91-700 689-15	3 - 8	95-742 436-71/895	19 - 1	95-742 726-91	11 - 1, 11 - 5	95-743 124-75/951	3 - 1
91-700 961-15	3 - 18	95-742 437-71/895	19 - 1	95-742 730-91	10 - 1	95-743 132-15	3 - 14
91-701 179-15	3 - 4	95-742 445-01	19 - 1	95-742 742-15	11 - 5	95-743 170-75/893	5 - 1
91-701 344-25	11 - 9	95-742 446-01	19 - 1	95-742 746-15	6 - 4	95-743 171-75/893	5 - 1
91-701 685-25	7 - 3	95-742 447-01	19 - 1	95-742 772-71/951	11 - 1	95-743 250-75/895	8 - 2
94-744 091-71/895	7 - 6	95-742 448-01	19 - 2	95-742 773-71/895	11 - 1	95-743 252-15	8 - 2
95-144 188-15	6 - 5	95-742 449-01	19 - 2	95-742 774-15	6 - 1	95-743 277-05	7 - 3
95-632 607-05	6 - 1	95-742 450-01	19 - 1	95-742 775-15	5 - 4	95-743 279-11	7 - 3
95-633 660-91	14 - 6	95-742 451-01	19 - 1	95-742 777-15	6 - 1, 6 - 2	95-743 282-05	7 - 5
95-665 735-91	18 - 1	95-742 452-71/895	19 - 1	95-742 778-15	6 - 1	95-743 307-05	13 - 2
95-702 555-71/893	15 - 13	95-742 455-01	19 - 1	95-742 784-05	11 - 9	95-743 313-05	13 - 2
95-704 618-01	6 - 4	95-742 488-15	11 - 2	95-742 787-91	9 - 5	95-743 314-05	13 - 2
95-723 644-01	6 - 5	95-742 490-01	3 - 5	95-742 789-01	7 - 3	95-743 315-05	13 - 1
95-735 664-01	3 - 11	95-742 627-91	12 - 5	95-742 827-05	6 - 4	95-743 320-75/893	14 - 2
95-742 207-91	3 - 13	95-742 628-75/951	12 - 5	95-742 835-15	6 - 4	95-743 338-75/951	5 - 1
95-742 210-71/895	3 - 1	95-742 633-12	3 - 10	95-742 841-05	6 - 1	95-743 357-05	7 - 5
95-742 401-25	19 - 1	95-742 639-75/951	3 - 6	95-742 845-75/895	9 - 1	95-743 358-05	7 - 5
95-742 402-71/895	19 - 1	95-742 678-15	7 - 5	95-742 846-71/895	9 - 1	95-743 360-01	7 - 5
95-742 405-71/895	19 - 1	95-742 679-05	7 - 1	95-742 867-15	9 - 1	95-743 368-92	7 - 5
95-742 411-75/895	19 - 1	95-742 682-05	12 - 2	95-742 874-05	9 - 1	95-743 372-15	7 - 6
95-742 413-75/895	19 - 2	95-742 683-15	12 - 1	95-742 883-75/895	9 - 1	95-743 375-05	7 - 6
95-742 417-15	19 - 1	95-742 684-15	12 - 1	95-742 884-15	9 - 2	95-743 383-92	7 - 6
95-742 418-15	19 - 2	95-742 690-11	9 - 5	95-742 891-05	9 - 2	95-743 387-75/895	7 - 6
95-742 421-15	19 - 1	95-742 692-05	9 - 5	95-742 900-71/951	5 - 2, 5 - 4	95-743 388-75/893	7 - 2
95-742 422-75/895	19 - 2	95-742 694-05	9 - 5	95-742 904-71/951	5 - 2, 5 - 4	95-743 393-05	7 - 5
95-742 423-05	19 - 2	95-742 695-05	7 - 3	95-742 913-05	5 - 1, 5 - 4	95-743 394-05	7 - 5
95-742 427-05	19 - 2	95-742 696-05	7 - 3	95-742 917-05	5 - 2	95-743 398-11	7 - 2
95-742 429-71/895	19 - 1	95-742 704-75/895	11 - 3	95-742 925-05	5 - 4	95-743 412-15	7 - 1
95-742 430-15	19 - 2	95-742 720-05	11 - 7	95-742 964-05	8 - 2	95-743 476-91	3 - 14

No.	Seite Page Pages Página	No.	Seite Page Pages Página	No.	Seite Page Pages Página	No.	Seite Page Pages Página
95-743 592-75/893	3 - 12	95-743 873-05	8 - 5	95-744 120-91	6 - 1	95-744 211-91	5 - 1, 5 - 4
95-743 594-15	3 - 10	95-743 899-01	8 - 2	95-744 122-15	11 - 6, 11 - 8	95-744 213-15	5 - 2
95-743 595-15	3 - 12	95-743 900-01	8 - 2	95-744 123-91	11 - 5	95-744 214-15	5 - 2
95-743 601-01	14 - 2	95-743 901-01	8 - 5	95-744 126-15	11 - 5	95-744 215-71/951	5 - 4
95-743 602-01	14 - 2	95-743 905-03/005	9 - 5	95-744 128-15	11 - 5	95-744 217-75/951	5 - 4
95-743 606-75/895	15 - 1	95-743 905-03/006	9 - 5	95-744 129-15	11 - 5	95-744 221-75/893	5 - 3
95-743 613-71/893	14 - 2	95-743 905-03/007	9 - 5	95-744 130-71/895	11 - 8	95-744 222-05	5 - 1
95-743 615-05	5 - 2	95-743 908-71/951	8 - 5	95-744 132-91	11 - 1	95-744 229-91	8 - 4
95-743 616-05	5 - 2	95-743 911-15	7 - 3	95-744 133-91	11 - 5	95-744 248-91	8 - 2
95-743 617-05	5 - 2	95-743 923-05	9 - 2	95-744 134-91	11 - 1	95-744 250-11	8 - 2
95-743 621-05	5 - 4	95-743 924-05	9 - 2	95-744 135-91	11 - 5	95-744 253-15	8 - 2
95-743 622-05	5 - 4	95-743 993-91	7 - 6	95-744 137-75/951	11 - 4	95-744 255-05	8 - 5
95-743 672-75/895	9 - 5	95-743 995-15	7 - 3	95-744 139-15	11 - 7	95-744 257-91	6 - 3
95-743 675-05	11 - 9	95-743 997-11	7 - 2	95-744 140-15	11 - 3	95-744 258-15	6 - 3
95-743 676-75/895	11 - 9	95-744 015-91	7 - 4	95-744 142-71/951	13 - 1	95-744 259-15	6 - 3, 6 - 4
95-743 677-15	11 - 9	95-744 025-05	7 - 3	95-744 145-15	13 - 2	95-744 260-01	6 - 3, 6 - 4
95-743 689-75/951	8 - 5	95-744 027-15	9 - 1	95-744 165-71/951	11 - 9	95-744 262-15	6 - 4
95-743 690-75/951	8 - 5	95-744 045-05	7 - 3, 7 - 5	95-744 166-75/951	11 - 1	95-744 263-15	6 - 2
95-743 693-05	12 - 6	95-744 050-15	7 - 2	95-744 186-91	6 - 5	95-744 265-15	6 - 4
95-743 699-05	12 - 5	95-744 056-91	11 - 9	95-744 187-15	6 - 5	95-744 266-15	6 - 2
95-743 718-15	9 - 4	95-744 062-05	11 - 5	95-744 189-15	6 - 5	95-744 268-91	6 - 2, 6 - 4
95-743 720-75/951	9 - 4	95-744 063-91	11 - 5	95-744 190-15	6 - 5	95-744 269-15	6 - 4
95-743 735-75/951	11 - 7	95-744 068-71/895	11 - 9	95-744 193-15	6 - 3	95-744 270-15	6 - 4
95-743 747-15	12 - 1	95-744 069-05	11 - 3, 11 - 9	95-744 194-15	6 - 3	95-744 271-05	6 - 4
95-743 775-05	7 - 5	95-744 089-71/893	7 - 2	95-744 196-15	6 - 5	95-744 272-15	6 - 4
95-743 801-75/893	14 - 8	95-744 090-71/893	7 - 1	95-744 197-11	6 - 2	95-744 295-75/893	12 - 4
95-743 817-71/951	3 - 14	95-744 092-71/895	7 - 3	95-744 200-71/951	5 - 4	95-744 300-15	12 - 2
95-743 818-15	12 - 8	95-744 093-01	9 - 5	95-744 201-15	5 - 1	95-744 305-71/893	12 - 1
95-743 821-71/893	3 - 10	95-744 100-71/893	5 - 2	95-744 206-05	5 - 2	95-744 307-75/893	12 - 2
95-743 832-05	7 - 3	95-744 108-71/951	5 - 2	95-744 207-05	5 - 4	95-744 309-61	12 - 1
95-743 833-05	7 - 5	95-744 109-75/951	5 - 4	95-744 208-71/951	5 - 2	95-744 312-71/893	12 - 1
95-743 845-05	9 - 1	95-744 110-75/951	5 - 2	95-744 209-71/951	5 - 4	95-744 318-05	8 - 1
95-743 872-05	8 - 5	95-744 118-71/895	3 - 1	95-744 210-05	5 - 1	95-744 319-75/895	8 - 2

No.	Seite Page Pages Página	No.	Seite Page Pages Página	No.	Seite Page Pages Página	No.	Seite Page Pages Página
95-744 329-71/895	15 - 1	95-744 462-75/895	11 - 4	95-744 601-15	11 - 9	95-783 978-91	15 - 9
95-744 330-71/895	15 - 1	95-744 463-75/951	11 - 3	95-744 602-15	11 - 9	95-783 979-91	15 - 9
95-744 340-71/893	10 - 1	95-744 464-15	11 - 2	95-744 604-01	3 - 2	95-783 980-91	15 - 9
95-744 348-05	12 - 4	95-744 465-15	11 - 4	95-744 680-05	12 - 2	95-783 981-91	15 - 9
95-744 349-11	12 - 7	95-744 467-11	11 - 4	95-744 681-05	12 - 2	95-783 982-91	15 - 9
95-744 352-15	12 - 8	95-744 468-15	11 - 1	95-744 778-75/893	12 - 2	95-783 986-91	15 - 8
95-744 366-71/893	12 - 2	95-744 469-15	11 - 5	95-752 019-75/895	15 - 1	95-783 988-91	15 - 8
95-744 367-71/893	12 - 8	95-744 471-71/895	11 - 3	95-752 122-71/893	3 - 11	95-783 994-91	15 - 12
95-744 369-15	12 - 8	95-744 474-12	11 - 1, 11 - 2, 11 - 4	95-752 123-05	3 - 11	95-783 995-91	15 - 6
95-744 373-75/895	10 - 1	95-744 475-91	11 - 9	95-752 124-75/893	3 - 11	95-783 996-91	15 - 5
95-744 381-91	6 - 1	95-744 479-75/895	8 - 1	95-752 125-75/893	3 - 11	95-783 997-91	15 - 9
95-744 391-11	9 - 1	95-744 481-71/951	3 - 1	95-752 126-75/893	3 - 11	95-783 998-91	15 - 5
95-744 392-75/895	9 - 1	95-744 488-15	3 - 1	95-753 856-05	6 - 4	95-783 999-91	15 - 5
95-744 393-15	9 - 2	95-744 490-71/895	8 - 4	95-774 076-71/893	4 - 1	95-784 025-91	15 - 8
95-744 395-71/895	8 - 5	95-744 492-05	8 - 4	95-774 195-15	6 - 2	95-784 100-91	15 - 5
95-744 397-15	8 - 2	95-744 500-75/895	6 - 4	95-774 219-15	5 - 1	95-784 101-91	15 - 5
95-744 398-75/895	8 - 1	95-744 501-15	6 - 2	95-774 487-15	4 - 1	95-784 102-91	15 - 5
95-744 399-75/893	8 - 4	95-744 502-15	6 - 2	95-783 912-91	15 - 10	95-784 104-91	15 - 5
95-744 400-75/893	8 - 5	95-744 506-15	11 - 8	95-783 951-91	15 - 4, 15 - 12	95-784 105-91	15 - 5
95-744 401-75/893	8 - 3	95-744 508-71/951	11 - 1	95-783 952-91	15 - 4	95-784 106-91	15 - 5
95-744 402-75/893	8 - 2, 8 - 3	95-744 560-71	10 - 1	95-783 954-91	15 - 4	95-784 107-91	15 - 5
95-744 409-75/895	15 - 2	95-744 561-91	5 - 1	95-783 955-91	15 - 4	95-784 108-91	15 - 5
95-744 412-91	12 - 2	95-744 562-91	9 - 5	95-783 959-91	15 - 3	95-784 109-91	15 - 5
95-744 415-71/893	12 - 2	95-744 563-15	6 - 4	95-783 960-91	15 - 4, 15 - 12	95-784 110-91	15 - 5
95-744 418-15	12 - 1	95-744 580-70/895	3 - 2	95-783 962-91	15 - 4	95-784 111-91	15 - 5
95-744 431-91	14 - 2, 14 - 3	95-744 581-15	3 - 2	95-783 966-91	15 - 4, 15 - 12	95-784 113-91	15 - 5
95-744 432-91	14 - 2, 14 - 4	95-744 582-71/895	3 - 2	95-783 967-91	15 - 6	95-784 120-91	15 - 12
95-744 448-15	5 - 3	95-744 584-15	3 - 2	95-783 968-91	15 - 6	95-784 121-91	15 - 7
95-744 450-71/895	8 - 2	95-744 586-05	3 - 2	95-783 969-91	15 - 6	95-784 122-91	15 - 5
95-744 453-75/893	10 - 1	95-744 592-21	3 - 2	95-783 974-91	15 - 9	95-784 123-91	3 - 6, 15 - 7
95-744 454-70/893	10 - 1	95-744 594-01	3 - 2	95-783 975-91	15 - 9	95-784 128-91	3 - 11
95-744 460-15	11 - 3	95-744 596-71/951	3 - 2	95-783 976-91	15 - 9	95-784 129-91	15 - 12
95-744 461-15	11 - 3	95-744 597-15	3 - 2	95-783 977-91	15 - 9	95-784 130-91	15 - 12

No.	Seite Page Pages Página	No.	Seite Page Pages Página	No.	Seite Page Pages Página	No.	Seite Page Pages Página
95-784 131-91	15 - 12	99-134 109-91	6 - 2, 6 - 3	99-135 548-91	12 - 1	99-136 904-91	7 - 3
95-784 133-91	15 - 1, 15 - 12	99-134 135-91	6 - 2	99-135 549-91	3 - 23, 6 - 2, 6 - 3	99-136 909-91	8 - 4
95-784 134-91	11 - 4	99-134 149-91	4 - 1	99-135 601-05	14 - 1	99-136 910-91	8 - 4
95-784 135-91	11 - 2	99-134 252-91	6 - 3	99-135 613-91	14 - 1	99-136 911-91	12 - 4
95-784 137-91	15 - 10	99-134 259-91	6 - 3	99-135 614-91	13 - 1	99-136 920-91	9 - 4
95-784 138-91	15 - 10	99-134 336-91	6 - 3	99-135 798-05	14 - 1	99-136 954-05	11 - 6, 11 - 8
95-784 140-71/895	15 - 12	99-134 358-91	5 - 3	99-135 890-91	8 - 4	99-137 011-91	14 - 6
95-784 141-73/002	15 - 10	99-134 417-91	3 - 2	99-135 911-91	6 - 2	99-137 080-91	19 - 2
95-784 142-71/893	15 - 3	99-134 505-05	6 - 1	99-135 920-91	3 - 23	99-137 082-91	19 - 1
95-784 166-91	15 - 7	99-134 520-91	5 - 3, 9 - 3, 11 - 9	99-136 030-91	12 - 6	99-137 151-45	3 - 9
95-784 147-73/001	15 - 1	99-134 586-91	8 - 1	99-136 104-95	15 - 1	99-137 204-91	12 - 2
95-784 167-91	15 - 5	99-134 591-91	12 - 7	99-136 121-91	14 - 6		
95-784 168-91	15 - 5	99-134 833-91	5 - 3, 8 - 3	99-136 128-91	14 - 4, 14 - 7		
95-784 239-01	15 - 4	99-134 838-91	8 - 3	99-136 129-91	14 - 3, 14 - 4, 14 - 5		
95-784 240-01	15 - 4	99-134 850-91	5 - 3, 7 - 4, 8 - 1, 8 - 3, 8 - 4, 11 - 9, 14 - 8	99-136 134-91	14 - 3, 14 - 4		
95-784 245-91	15 - 7		9 - 3, 12 - 6	99-136 167-91	8 - 1		
95-784 258-91	15 - 5	99-134 851-91	9 - 3, 12 - 6	99-136 204-91	14 - 8		
95-784 267-91	15 - 2	99-134 886-91	9 - 1	99-136 205-91	12 - 7, 14 - 9		
95-784 270-91	12 - 2, 15 - 9	99-134 957-91	19 - 1	99-136 342-91	14 - 1		
95-784 298-91	15 - 9	99-134 960-91	3 - 14, 12 - 1	99-136 433-91	12 - 1		
95-784 312-91	10 - 1	99-135 107-91	14 - 9	99-136 470-95	19 - 1		
95-784 313-91	15 - 3	99-135 206-91	3 - 23	99-136 503-91	11 - 6, 11 - 8		
95-784 994-91	15 - 5	99-135 233-91	3 - 14, 6 - 2, 7 - 1, 7 - 2, 19 - 1, 19 - 2	99-136 556-91	9 - 2		
99-115 425-91	6 - 3, 7 - 3, 9 - 1	99-135 254-91	12 - 1	99-136 590-01	11 - 7		
99-115 505-91	7 - 2, 7 - 4, 9 - 3, 12 - 7	99-135 298-91	3 - 2, 8 - 4, 9 - 2, 9 - 4	99-136 632-91	3 - 14		
99-115 589-91	14 - 7	99-135 351-91	14 - 1	99-136 661-91	9 - 3		
99-115 591-91	14 - 3, 14 - 4	99-135 352-05	14 - 1	99-136 685-91	7 - 2		
99-133 042-91	14 - 7	99-135 353-91	14 - 1	99-136 688-05	7 - 2		
99-133 122-91	14 - 9	99-135 354-05	14 - 1	99-136 700-55	12 - 3		
99-133 124-91	14 - 5	99-135 417-91	5 - 3	99-136 701-91	7 - 2		
99-133 125-91	14 - 5	99-135 431-91	14 - 6	99-136 702-91	7 - 1		
99-133 127-91	14 - 5	99-135 490-91	14 - 5	99-136 899-45	15 - 1		
99-133 645-91	14 - 8	99-135 496-95	14 - 7	99-136 901-91	12 - 1		

PFAFF