

337

TEILELISTE

PARTS LIST

LISTE DE PIÈCES

零件表

Diese Teileliste hat für Maschinen ab nachfolgender
Seriennummer Gültigkeit:

This parts list applies to machines from the following
serial numbers onwards:

Cette liste de pièces est valable pour les machines au
numéros de série à partir de:

本零件表对从下列系列号起的机器有效:

7 207 686 →

Alle Informationen und Abbildungen waren zum Zeitpunkt der Druckgebung auf dem neusten Stand.

Technische Änderungen vorbehalten!

Der Nachdruck, die Vervielfältigung sowie die Übersetzung - auch auszugsweise - aus PFAFF-Teilelisten ist nur mit unserer vorherigen Zustimmung und mit der Quellenangabe gestattet.

At the time of printing, all information and illustrations contained in this document were up to date.

Subject to alteration!

The reprinting, copying or translation of PFAFF Parts lists whether in whole or in part, is only permitted with our previous permission and with written reference to the source.

Todas las informaciones e ilustraciones de este manual estaban al día en el momento de entregarse para su impresión.

¡ Salvo modificaciones técnicas!

La reimpresión, reproducción y traducción - aunque sólo sea parcial - de las listas de piezas PFAFF sólo está permitida con nuestro permiso previo e indicando la fuente.

所有信息和图片在付印时都是最新的。

保留技术更改的权力！

全部或部分翻印、复制以及翻译PFAFF-零件表必须事先经由我们同意并且注明来源。

**PFAFF Industriesysteme
und Maschinen AG**

Hans-Geiger-Str. 12 - IG Nord

D-67661 Kaiserslautern

	Seite Page Página 页
0 Wichtiger Hinweis	5
Important note	
Observación importante	
重要提示	
1 Vorwort	6
Foreword	
Notas preliminares	
前言	
2 Erläuterungen der Schlüsselzeichen	7
Explanation of key markings	
Explicaciones de los signos clave	
标记说明	
3 Basismaschine	
Basic machine	
Máquina básicas	
基础机器	
3.01 Gehäuseteile	9
Housing sections	
Piezas del cárter	
机身零件	
3.02 Kopfteile	10
Needle head parts	
Piezas de la cabeza	
机头零件	
3.03 Armteile	14
Arm parts	
Piezas del brazo	
机臂零件	
3.04 Freiarmteile	22
Cylinder bed parts	
Piezas del brazo al aire	
悬臂零件	
4 Abweichende Teile der PFAFF 337-G	25
Different parts for PFAFF 337-G	
Piezas de la PFAFF 337-G que son diferentes	
PFAFF 337-G 中有差别的零件	
5 Fadenabschneid-Einrichtung (-900/51)	26
Thread trimmer (-900/51)	
Cortahilos (-900/51)	
切线器 (-900/51)	
6 Presserfuß-Automatik (-910/98)	31
Automatic presser foot lifter (-910/98)	
Grupo acondicionador del aire comprimido (-910/98)	
压脚自动提升器 (-910/98)	
7 Optische Anzeigevorrichtung (-921/01)	32
Optical top feed variation indicator (-921/01)	
Señalizador óptico (-921/01)	
光学显示装置 (-921/01)	
8 Wartungseinheit	33
Air filter / lubricator	
Grupo acondicionador del aire comprimido	
保养单元	
9 Elektrische Ausrüstung	
Electrical equipment	
Equipo eléctrico	
电设备	

	Seite Page Página 页
9.01 Kabelbaum zum Oberteil.....	34
Cable tree to sewing head Mazo de cables para el cabezal 上部机器电缆束	
9.02 Oberteilerkennung	35
Sewing head identification Detección de la parte superior 机头识别	
9.03 Positionsgeber	35
Synchronizer Sincronizador 位置传感器	
9.04 Bedienfeld	36
Control panel Panel de mandos 操作板	
9.05 Anbausatz für externen Motor.....	37
Mounting kit for external motor Juego de piezas acoplables motor externo 用于外部电机的安装组件	
9.06 Sollwertgeber	38
Set-point generator Emisor del valor teórico 给定值发生器	
9.07 Steuerkasten	39
Control box Caja de mandos 控制箱	
9.08 Motor-Hauptschalter	40
Main switch Interruptor principal 电机主开关	
10 Garnrollenständer	41
Reel stands Portacarretes 线轴支架	
11 Einstellehren	42
Adjustment gauges Calibres de ajuste 设置量规	
12 Knielüfterteile	43
Knee lifter parts Piezas del alzaprensateles por rodillera 膝松线器零件	
13 Schmiermittel-Übersicht	45
Overview of lubricants Tabla de lubricantes 润滑剂一览	
14 Index (Teilenummern / Seitenzahlen)	46
Index (part numbers / page numbers) Index (números de pieza / números de página) 注脚(零件号/页号)	
15 Unterklassen-Ausstattung	
Subclass parts Composición de las subclases 子机型-设备	
15.01 Nähwerkzeuge (PFAFF 337)	52
Gauge parts (PFAFF 337) Organos de costura (PFAFF 337) 缝纫工具 (PFAFF 337)	

Achtung!



Wir machen ausdrücklich darauf aufmerksam, daß Ersatz- und Zubehörteile, die nicht von uns geliefert werden, auch nicht von uns geprüft und freigegeben sind. Der Einbau und / oder die Verwendung solcher Produkte kann daher u. Umständen konstruktiv vorgegebene Eigenschaften Ihrer Maschine negativ verändern. Für Schäden, die durch die Verwendung von Nicht-Originalteilen entstehen, übernehmen wir keine Haftung!

Caution!



We warn you expressively that spare parts and accessories that are not supplied by us are not tested and released by us. Fitting or using these products may therefore have negative influences on features that depend on the machine design. We are not liable for any damage caused by the use of non-Pfaff parts!

¡Atención!



Se hace observar que en el caso de piezas de recambio y accesorios que no hayan sido suministrados por nosotros, quiere decir que non han sido sometidas por nuestra parte a un control y que no se les ha dado el visto bueno. Por esta razón, el montaje y/o empleo de tales productos puede repercutir negativamente en las características previstas en su máquina. ¡Para los daños que eventualmente pudiesen presentarse al utilizar piezas no originales, no asumimos ninguna garantía!

注意!



我们必须明确指出，所有不是由我们供货的备件和附件都未经我们检查，也没有被我们批准使用。装入和/或使用这些产品可能在一定的情况下会对机器的设计特性造成负面改变。对由于使用非原装件所造成的损失，我们不负任何责任！

- Die Seriennummer der Maschine, für die diese Teileliste Gültigkeit hat, ist auf der Titelseite aufgeführt.
 - Alle Teile sind so abgebildet, wie sie in der Maschine funktionsmäßig zusammengehören.
 - Gestrichelt dargestellte Teile zeigen angrenzende Teile aus anderen Funktionsgruppen.
 - Im oberen Teil der Bildseiten befindet sich eine Gesamtansicht der Maschine .
 - Der Einbauort der dargestellten Teile wird durch eine gerasterte Fläche gekennzeichnet.
 - Einrahmungen auf den Bildseiten zeigen, aus welchen Einzelteilen sich die Gruppenteile zusammensetzen.
 - Die auf den Bildseiten verwendeten Schlüsselzeichen (; 2 ; 3 usw.) sind im Kapitel "Erläuterungen der Schlüsselzeichen" aufgelistet.
-
- The serial number of the machine to which this parts list applies is indicated on the cover page.
 - All parts are illustrated in function groups with the parts which they function together with in the machine.
 - Parts illustrated with broken lines are parts from other function groups which border on the illustrated function group.
 - The above section of the page of illustrations contains a total view of the machine. The place for the installation of the parts pictured here is marked by the grid.
 - The framed-in sections on the illustration pages show the individual parts comprising a group.
 - The key markings used on the illustrated pages (; 2 ; 3 etc.) are listed in the chapter "Explanation of key markings".
-
- El número de serie de la máquina para la cual tiene validez esta lista de piezas va indicado en la página de título.
 - Todas las piezas están ilustradas tal como aparecen en la máquina para su funcionamiento.
 - Las piezas representadas con rayitas muestran piezas colindantes de otros grupos de funciones.
 - En la parte superior de las páginas ilustradas se puede ver una vista en conjunto de la máquina.
 - El lugar de montaje de la pieza representada va caracterizada mediante una superficie reticulada.
 - Los recuadros en las páginas ilustradas indican las piezas individuales de que se componen los grupos.
 - Los signos clave (; 2 ; 3 etc.) empleados en las páginas con ilustraciones van listados en el capítulo "Explicaciones de los signos clave".
-
- 适用于本零件表的机器系列号列在首页上。
 - 所有的零件都按照其在机器中的功能情况合在一起表达。
 - 用虚线表示的零件为相邻功能组中的零件。
 - 图的上部为机器全景。
 - 所示零件的安装部位用影格面表示。
 - 页上的框表示这套组件都由哪些零件所组成。
 - 图页上所使用的标记 (; 2 ; 3 等) 列表在“标记说明”中。

- []** Unterklassenabhängig, Teilenummer siehe Unterklassen-Ausstattung.
Subclass-dependent, for part number see subclass parts listing.
Dependientes de la subclase, para el número de pieza véase "Dotación de subclases".
取决于子机型，零件号见子机型设备。
- B** **Maschinen-Ausstattung für mittlere Materialien.**
Model B for sewing thin medium-weight materials.
Tipo B para materiales semiligeros.
用于中厚料的机器设备。
- N36** **3,0 mm Schubweg des Untertransporteurs, 6,0 mm Schubweg des Obertransporteurs.**
3.0 mm bottom feed stroke, 6.0 mm top feed stroke.
3,0 mm de recorrido del transportador inferior, 6,0 mm del recorrido del transportador superior.
3.0 mm 下送料牙进给行程, 6.0 mm 上送料牙进给行程。
- 3** **Geklebt**
Part cemented
Pieza pegada
被粘住。
- 3/1** **Gesichert mit Loctite.**
Secured with loctite.
Asegurado con Loctite.
用 Loctite 粘胶固定。
- 6** **Nadeldicke und Spitzenform bei Bestellung angeben.**
Needle size and style of point to be stated on order.
Grosor de aguja y forma de la punta, indíquese en los pedidos.
在订货时给出针厚和针尖型式。
- 27/2** **Eingeklammerte Zahl = Dicke in mm.**
Number in brackets = thickness in mm.
Cifra entre paréntesis = espesor en mm.
括起的数字 = 厚度 (单位 mm)
- 27/5** **Eingeklammerte Zahl = Länge in mm.**
Number in brackets = length in mm.
Cifra entre paréntesis = largura en mm.
被括起的数字=长度, 单位mm。
- 40/2** **Tränken mit 28-011 201-44; Bestellnummer siehe Seite 45.**
Grease with 28-011 201-44; for part number see page 45.
Engrase con grasa 28-011 201-44; para el número de pedido véase la página 45.
浸油用 28-011 201-44; 订货号见 45 页。
- 40/3** **Fetten mit 28-011 202-47; Bestellnummer siehe Seite 45.**
Grease with 28-011 202-47; for part number see page 45.
Engrase con grasa 28-011 202-47; para el número de pedido véase la página 45.
上脂用 28-011 202-47; 订货号见 45 页。
- 40/4** **Fetten mit 28-011 202-43; Bestellnummer siehe Seite 45.**
Grease with 28-011 202-43; for part number see page 45.
Engrase con grasa 28-011 202-43; para el número de pedido véase la página 45.
上脂用 28-011 202-43; 订货号见 45 页。
- 40/13** **Fetten mit 28-011 202-05; Bestellnummer siehe Seite 45.**
Grease with 28-011 202-05; for part number see page 45.
Engrase con grasa 28-011 202-05; para el número de pedido véase la página 45.
上脂用 28-011 202-05; 订货号见 45 页。

- 90/1** **Für Wechselstrom**
For single-phase A.C.
Para corriente alterna monofásica
适用于交流电
- 90/51** **Großer Greifer.**
Large sewing hook.
Garfio grande.
大旋梭
- 90/52** **Kleiner Greifer.**
Small sewing hook.
Garfio pequeño
小旋梭
- 90/79** **Für Maschinen mit kleinem Greifer.**
For machines with small hook.
Para máquinas con garfio pequeño.
用于带小旋梭的机器
- 90/80** **Für Maschinen mit großem Greifer.**
For machines with large hook.
Para máquinas con garfio grande.
用于带大旋梭的机器
- 96** **Länge angeben**
State length
Indíquese la largura
给出长度

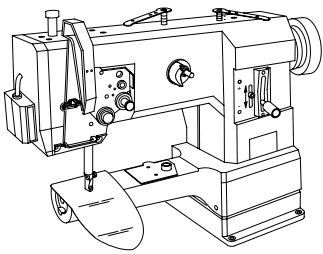

Gehäuseteile
Housing sections
Piezas del cárter
机身零件

PFAFF 337

3.01

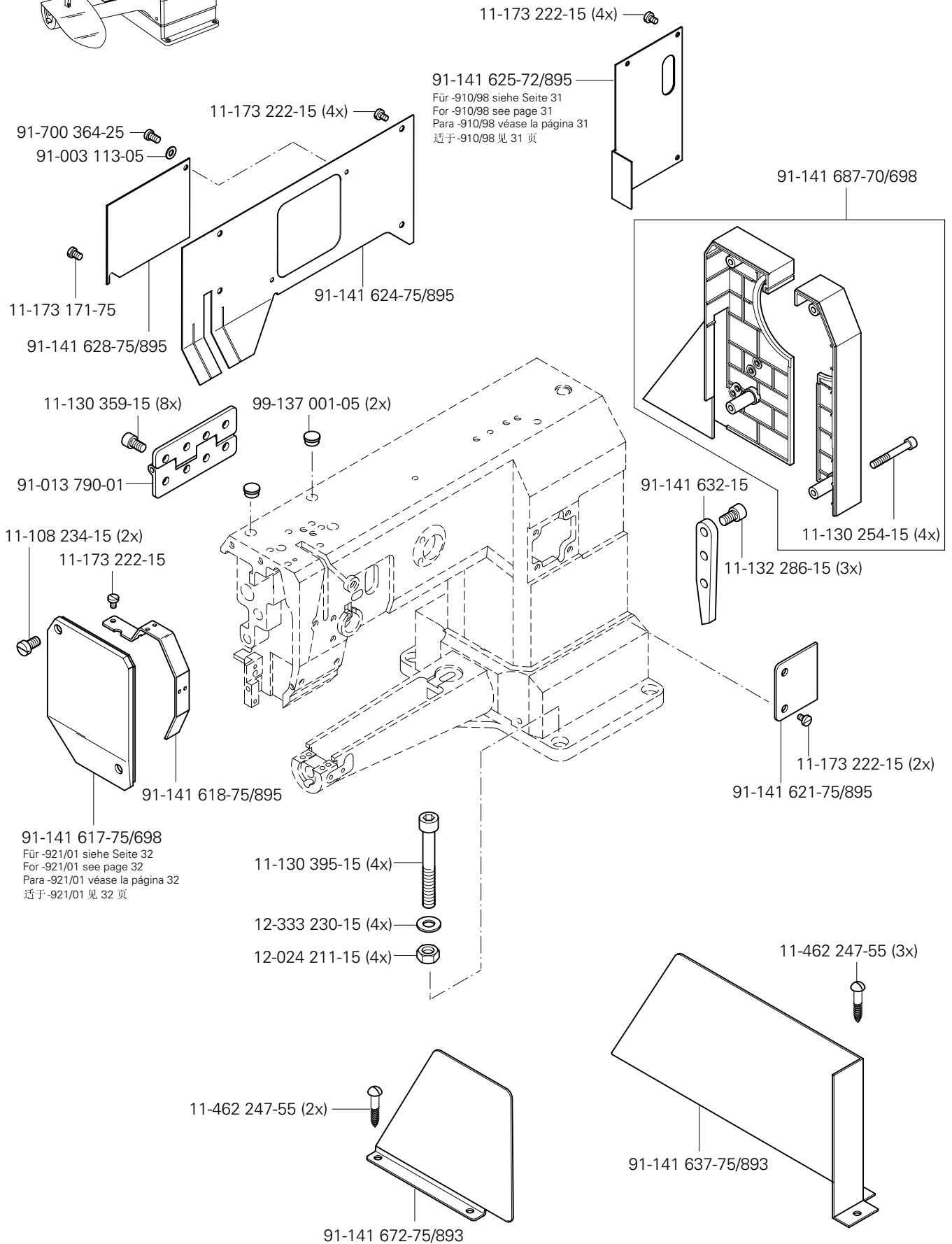

3.02

Kopfteile Needle head parts Piezas de la cabeza 机头零件

PFAFF 337

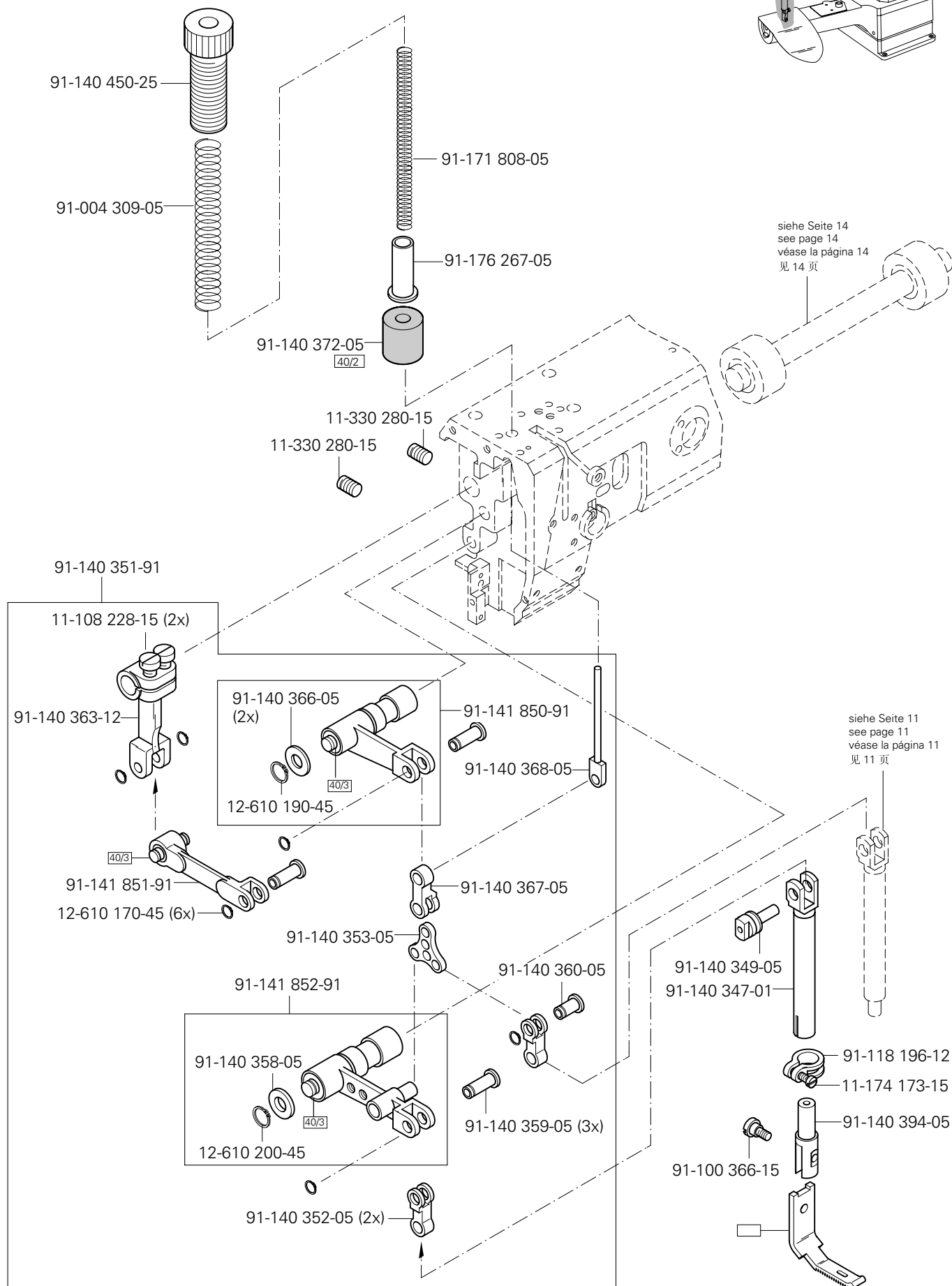
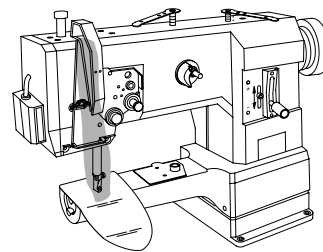

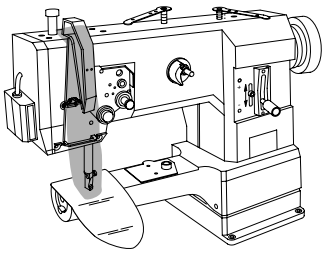

Kopfteile
Needle head parts
Piezas de la cabeza
机头零件

PFAFF 337

3.02

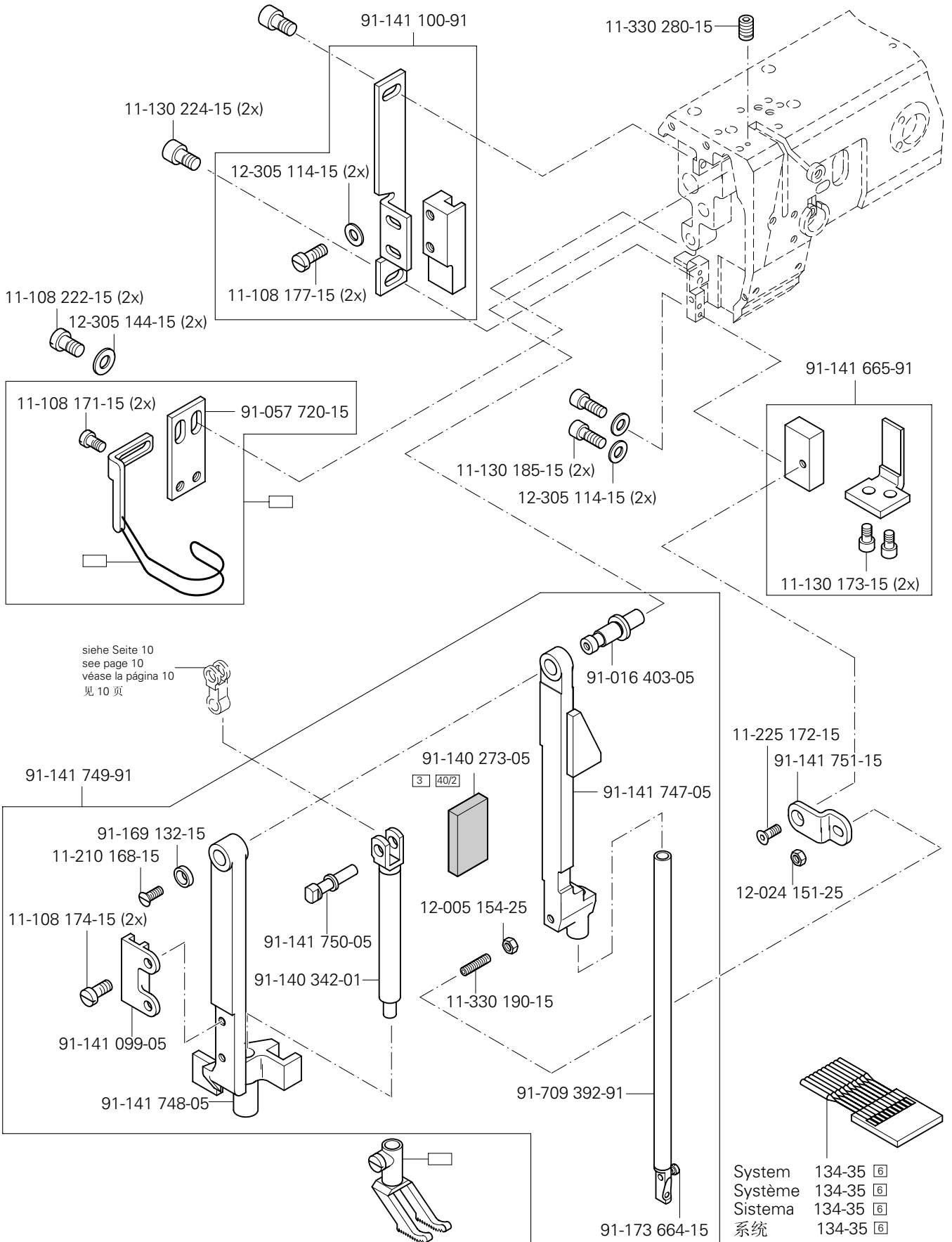

☐ siehe Kapitel 2 Erläuterung der Schlüsselzeichen
see chapter 2 Explanation of key markings
véase el Cap. 2 Explicaciones de los signos clave
见第2章标记说明

3.02

Kopfteile
Needle head parts
Piezas de la cabeza
机头零件

PFAFF 337

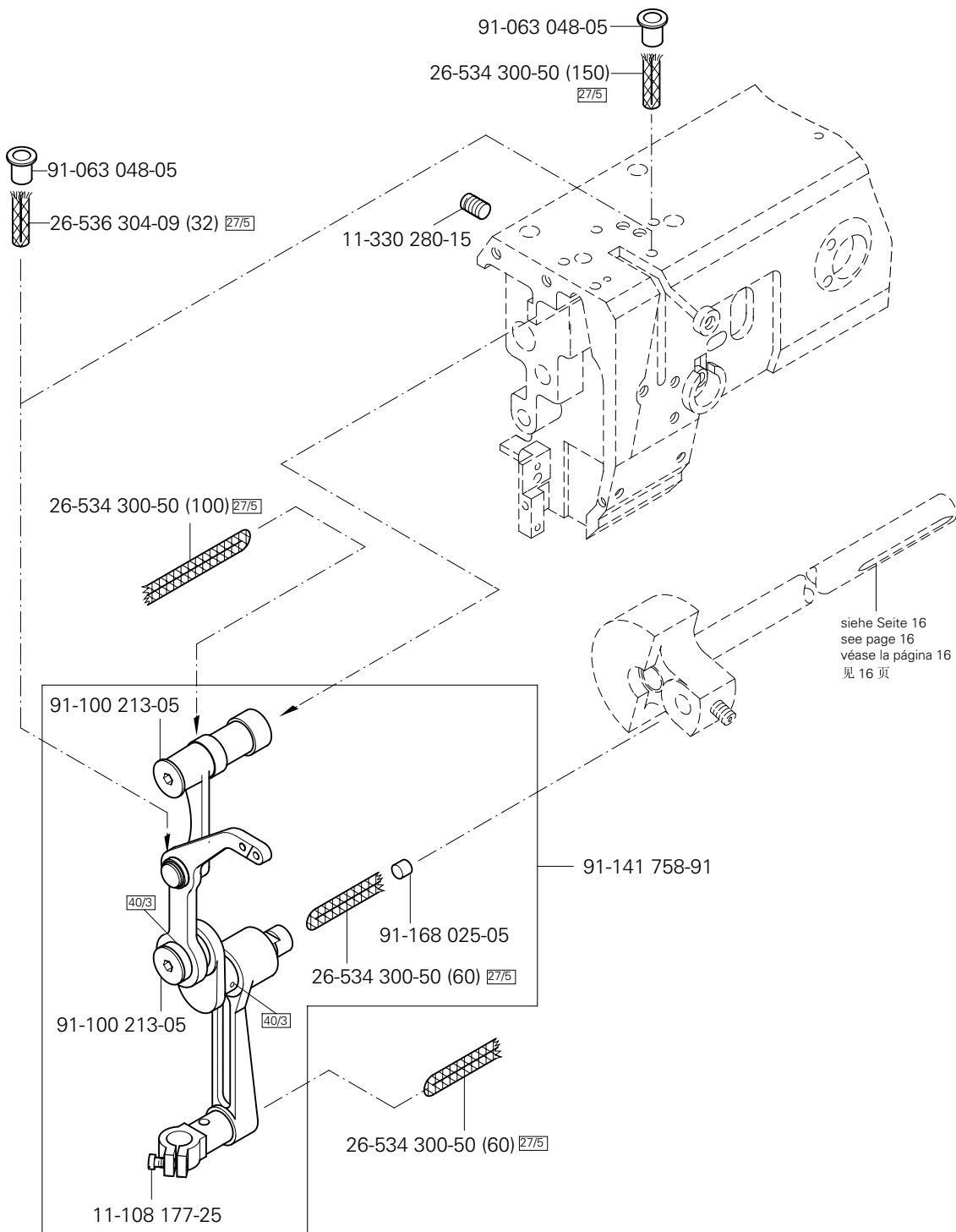
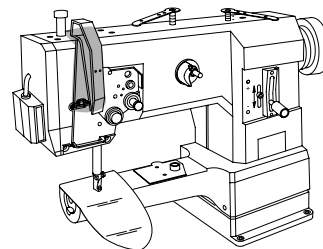

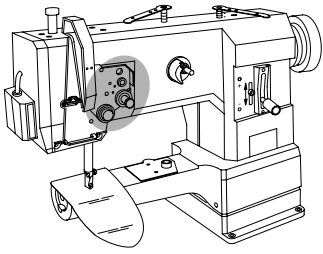

Kopfteile
Needle head parts
Piezas de la cabeza
机头零件

PFAFF 337

3.02

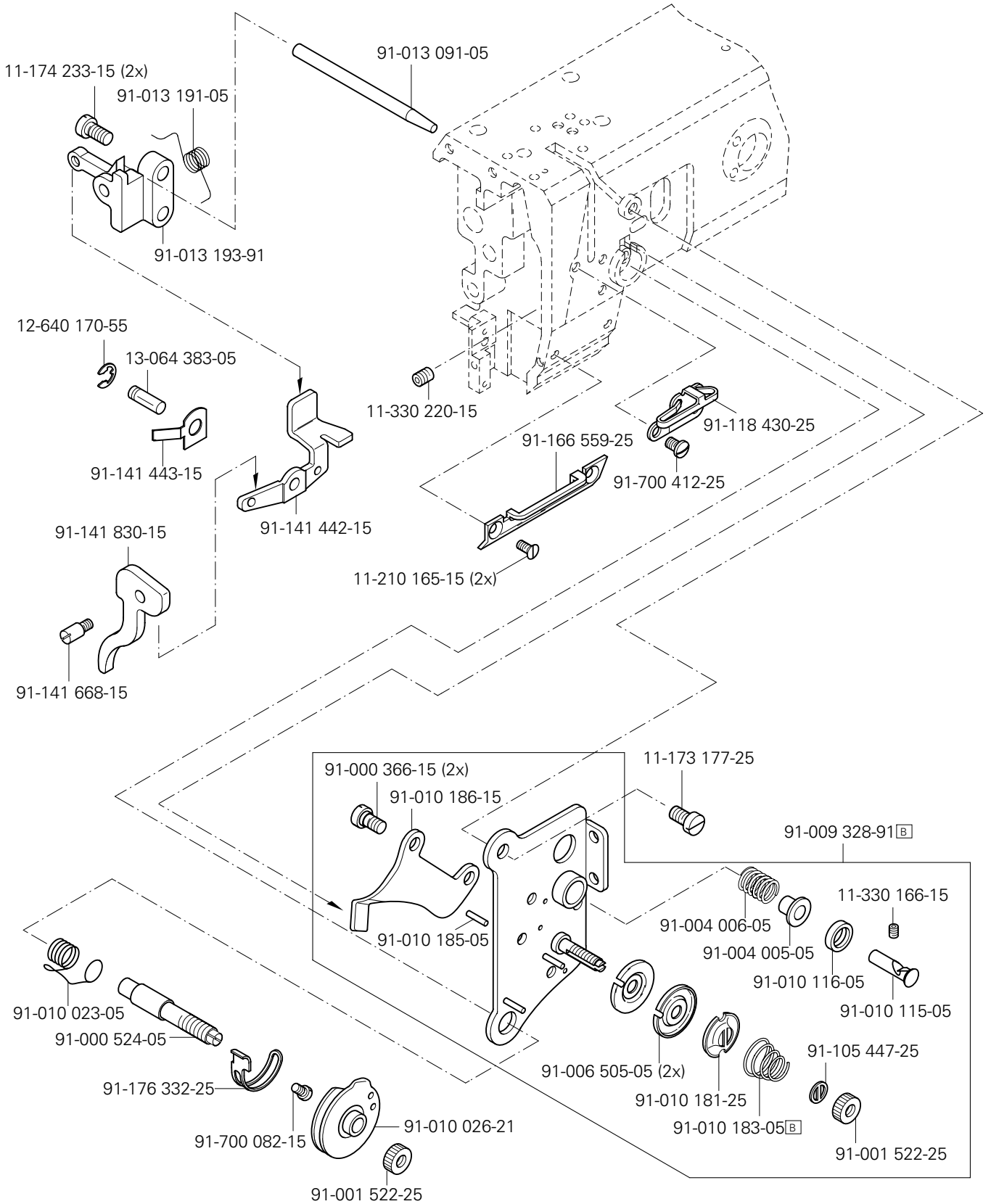

siehe Kapitel 2 Erläuterung der Schlüsselzeichen
 see chapter 2 Explanation of key markings
 véase el Cap. 2 Explicaciones de los signos clave
 见第2章标记说明

3.03

Armteile
 Arm parts
 Piezas del brazo
 机臂零件

PFAFF 337

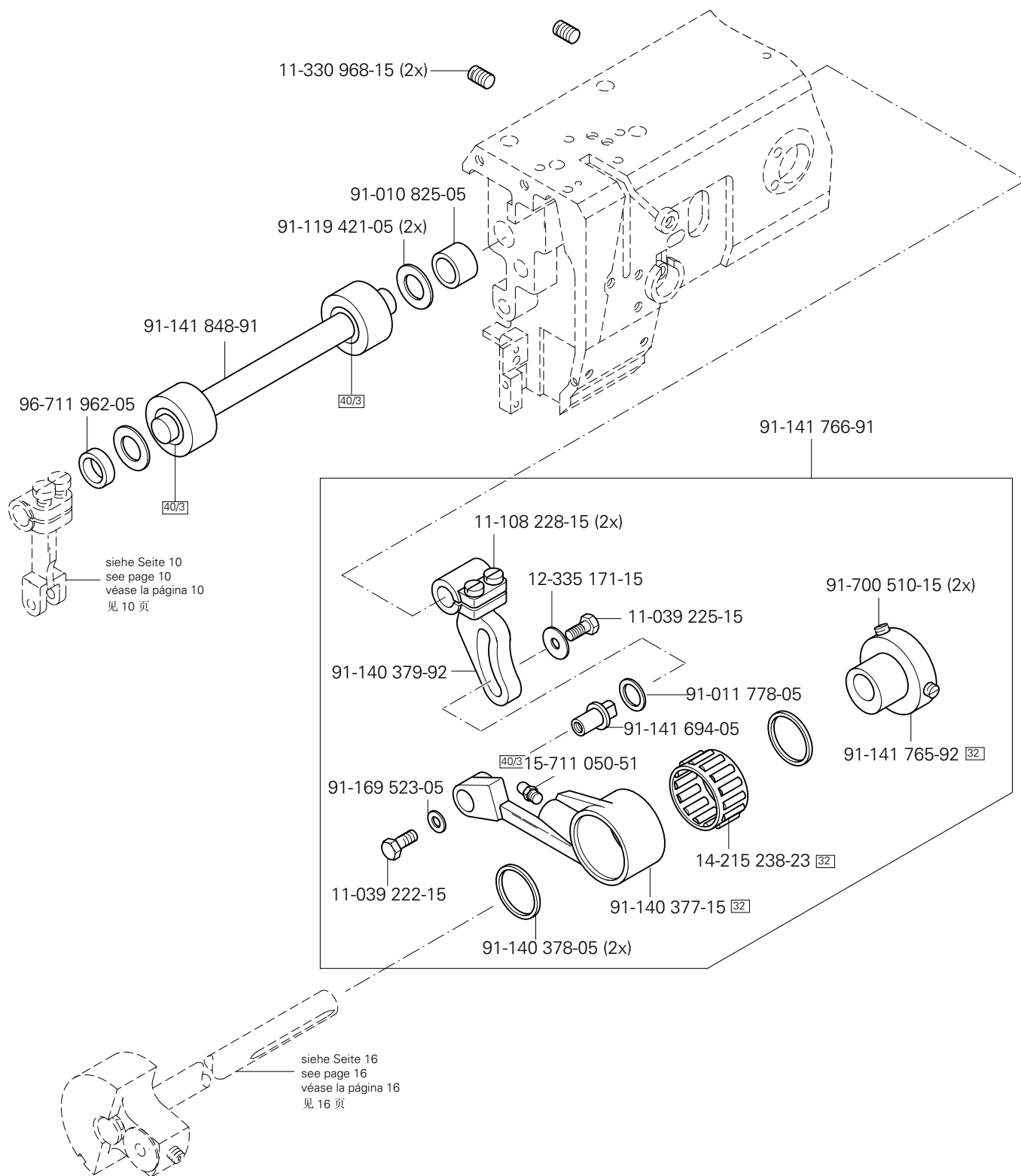
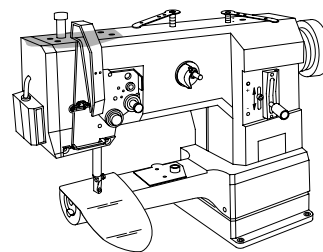

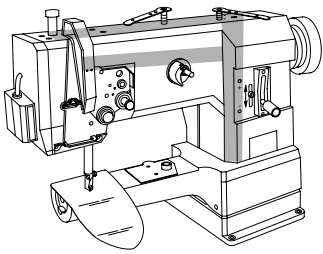

Armteile
 Arm parts
 Piezas del brazo
 机臂零件

PFAFF 337

3.03

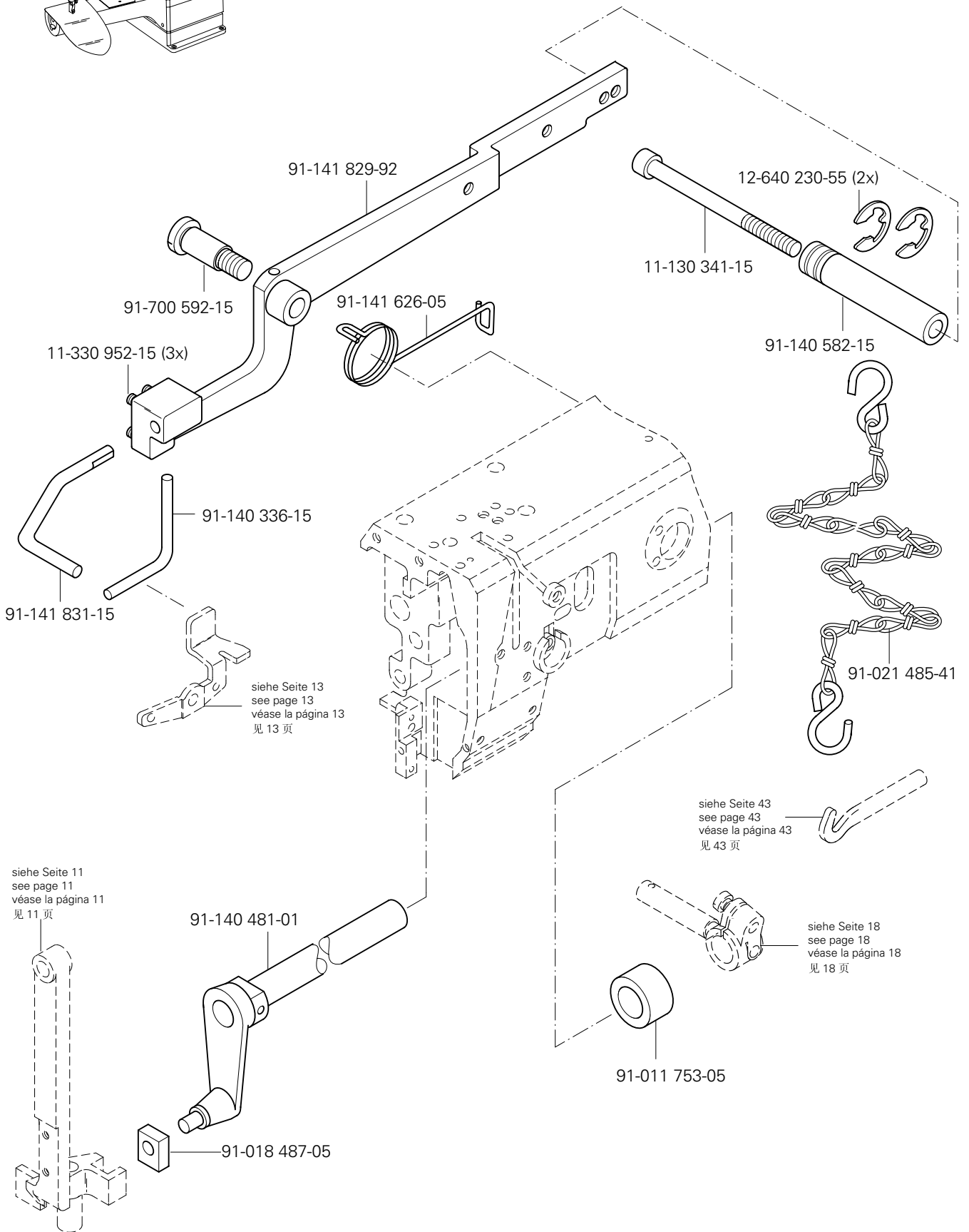

3.03

Armteile
 Arm parts
 Piezas del brazo
 机臂零件

PFAFF 337

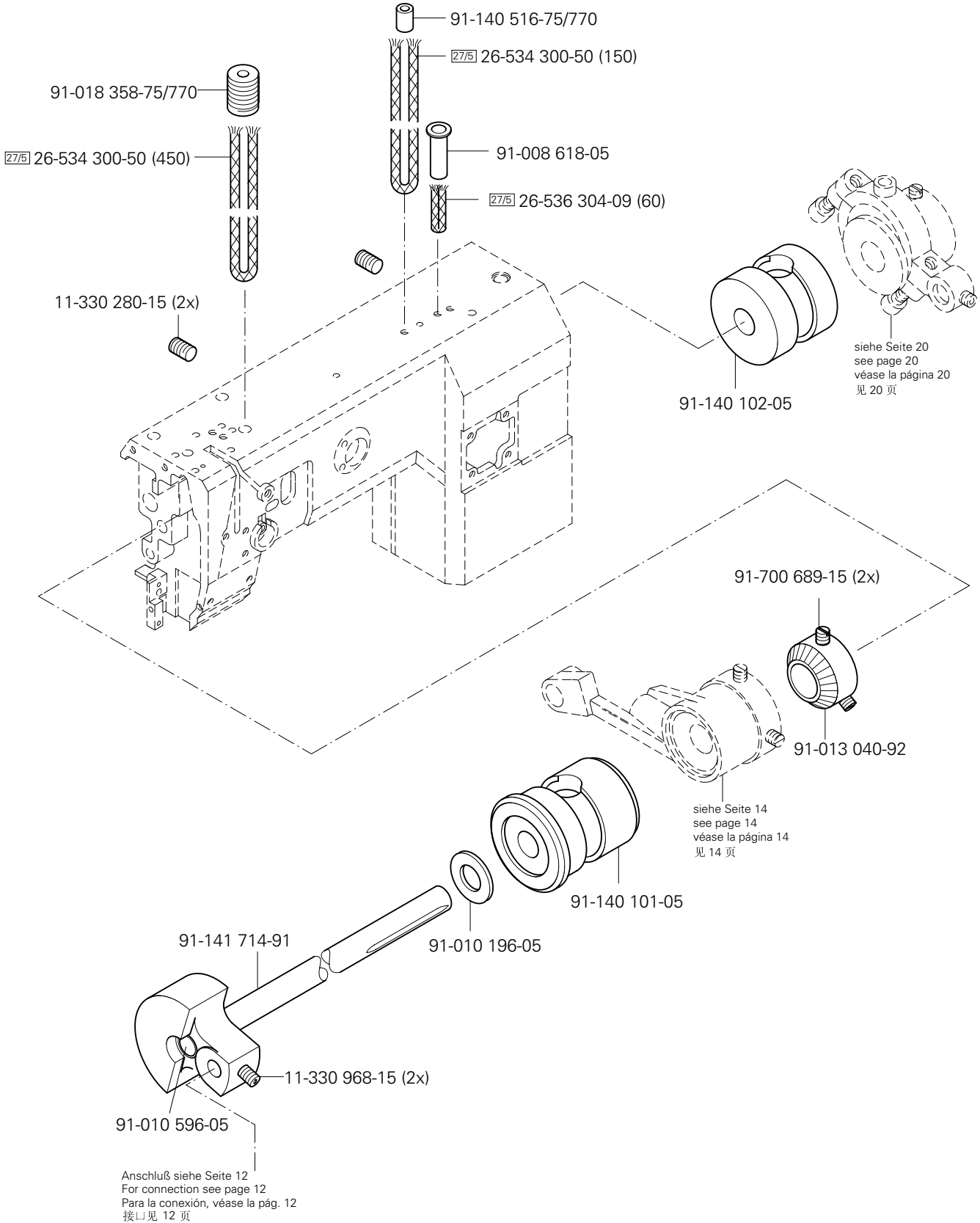
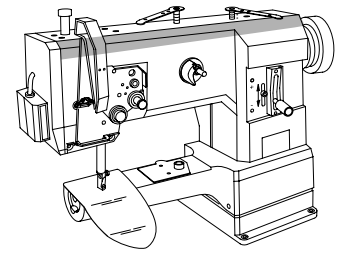

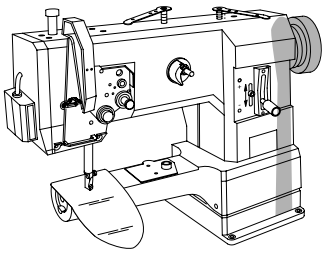

Armteile
 Arm parts
 Piezas del brazo
 机臂零件

PFAFF 337

3.03

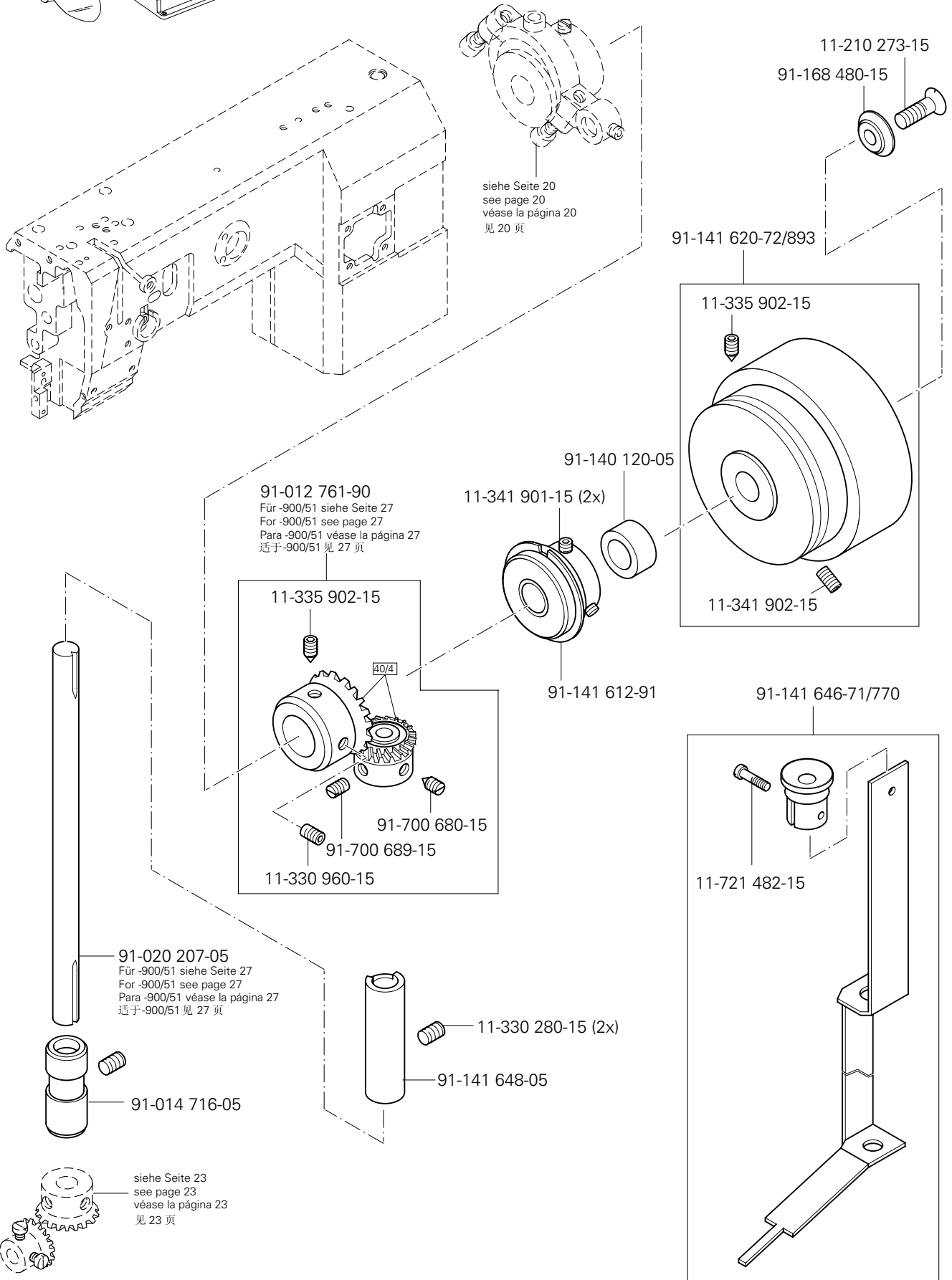

☐ siehe Kapitel 2 Erläuterung der Schlüsselzeichen
 see chapter 2 Explanation of key markings
 véase el Cap. 2 Explicaciones de los signos clave
 见第2章标记说明

3.03

Armteile
 Arm parts
 Piezas del brazo
 机臂零件

PFAFF 337

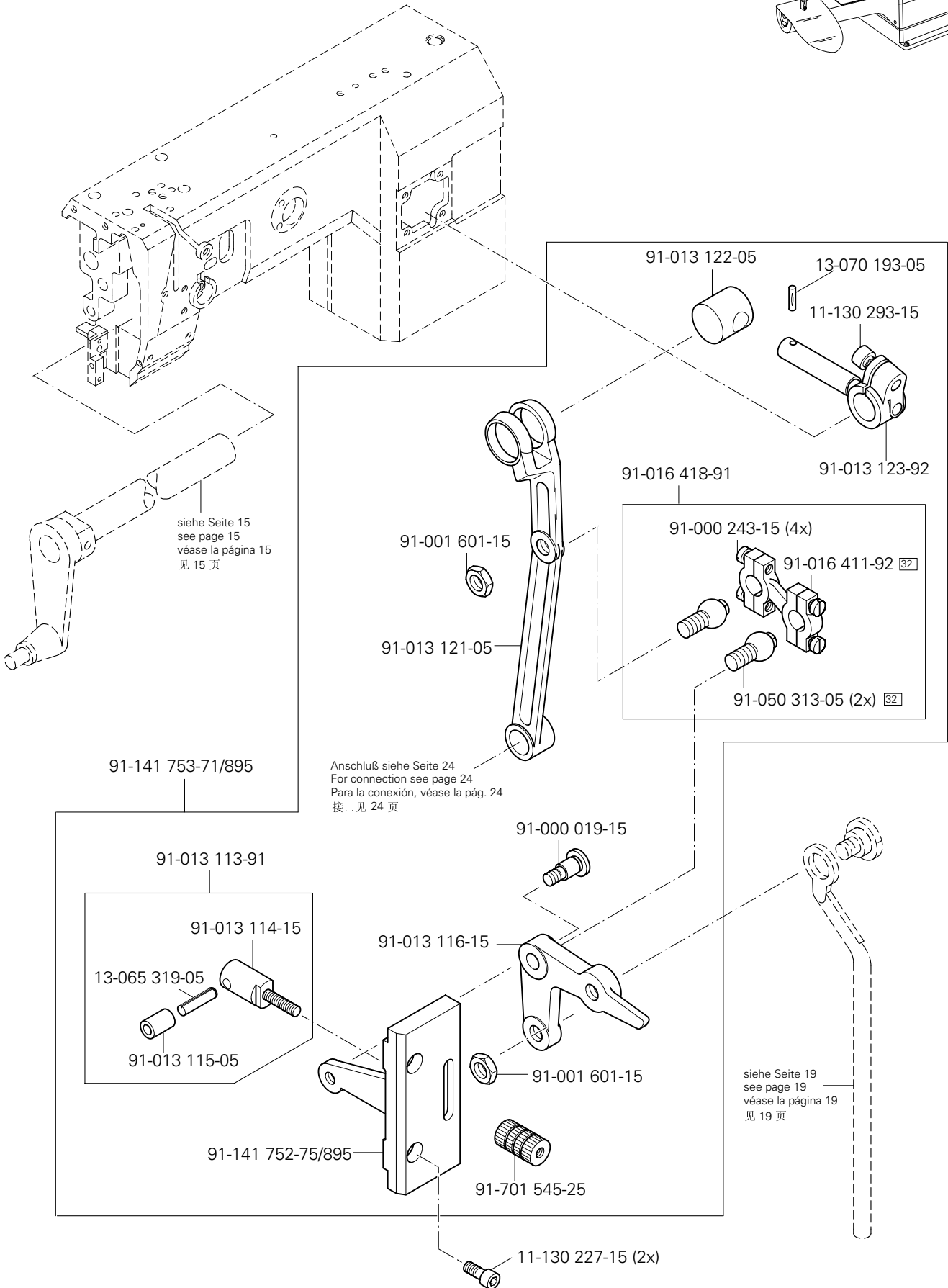
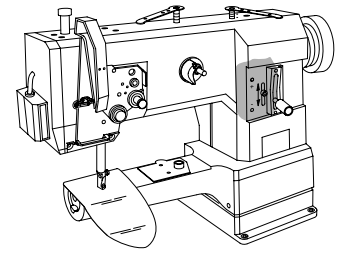

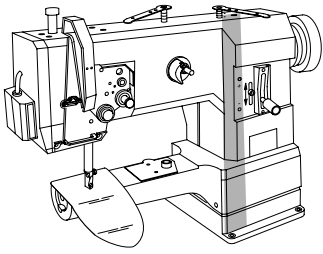

Armteile
 Arm parts
 Piezas del brazo
 机臂零件

PFAFF 337

3.03

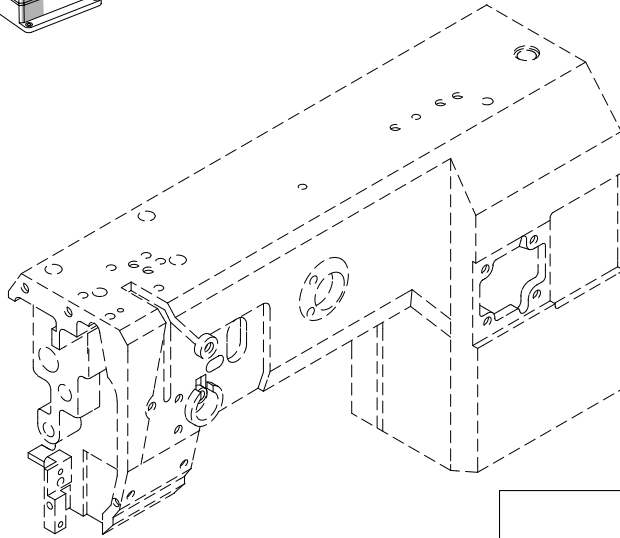

91-000 032-15



91-016 431-91

siehe Seite 18
 see page 18
 véase la página 18
 见 18 页

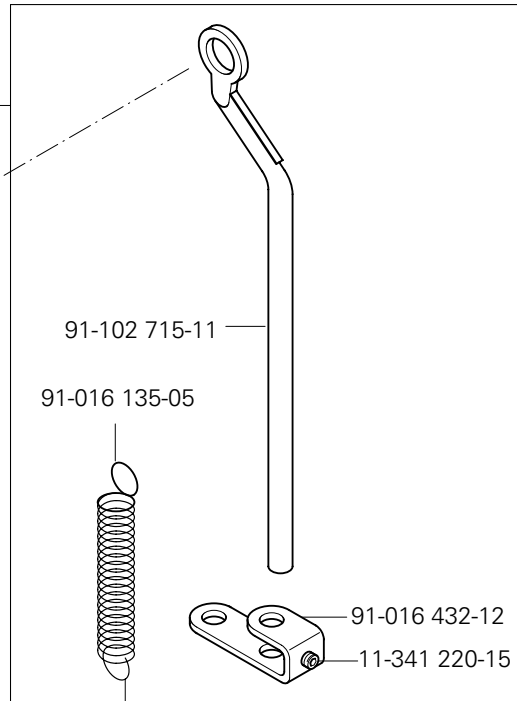
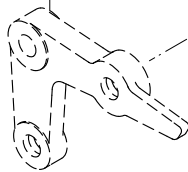

91-102 715-11

91-016 135-05

91-016 432-12

11-341 220-15

91-016 330-11



91-014 696-15



12-618 230-45

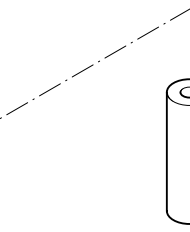

11-341 166-15

91-033 312-12



siehe Seite 43 und 44
 see page 43 and 44
 véase la página 43 y 44
 见 43 和 44 页

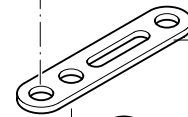

91-014 697-15



□ siehe Kapitel 2 Erläuterung der Schlüsselzeichen
 see chapter 2 Explanation of key markings
 véase el Cap. 2 Explicaciones de los signos clave
 见第2章标记说明

3.03

Armteile Arm parts Piezas del brazo 机臂零件

PFAFF 337

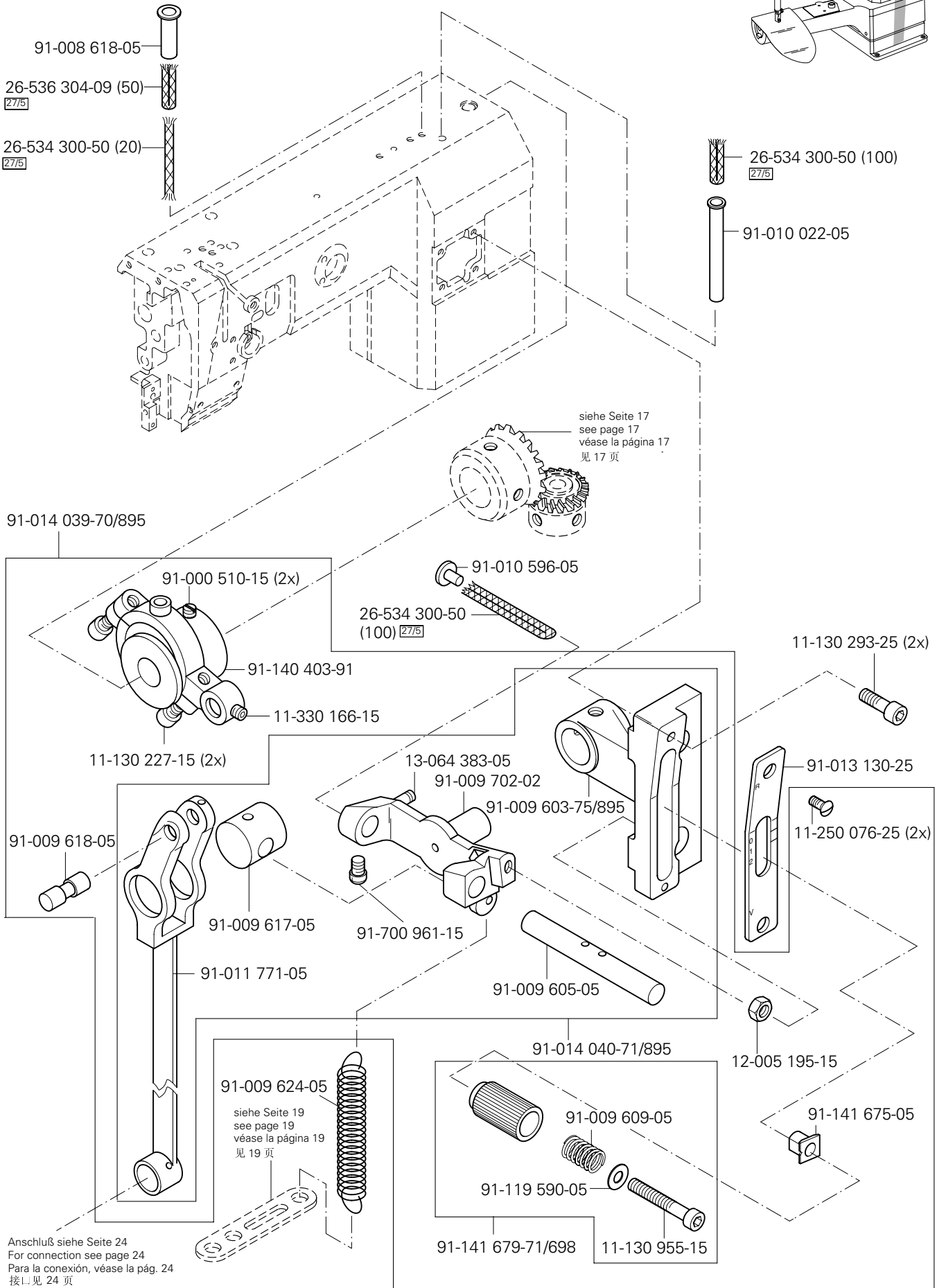
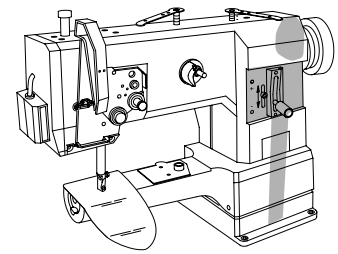

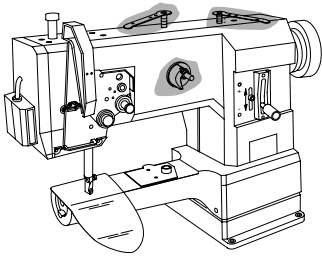

Armteile
 Arm parts
 Piezas del brazo
 机臂零件

PFAFF 337

3.03

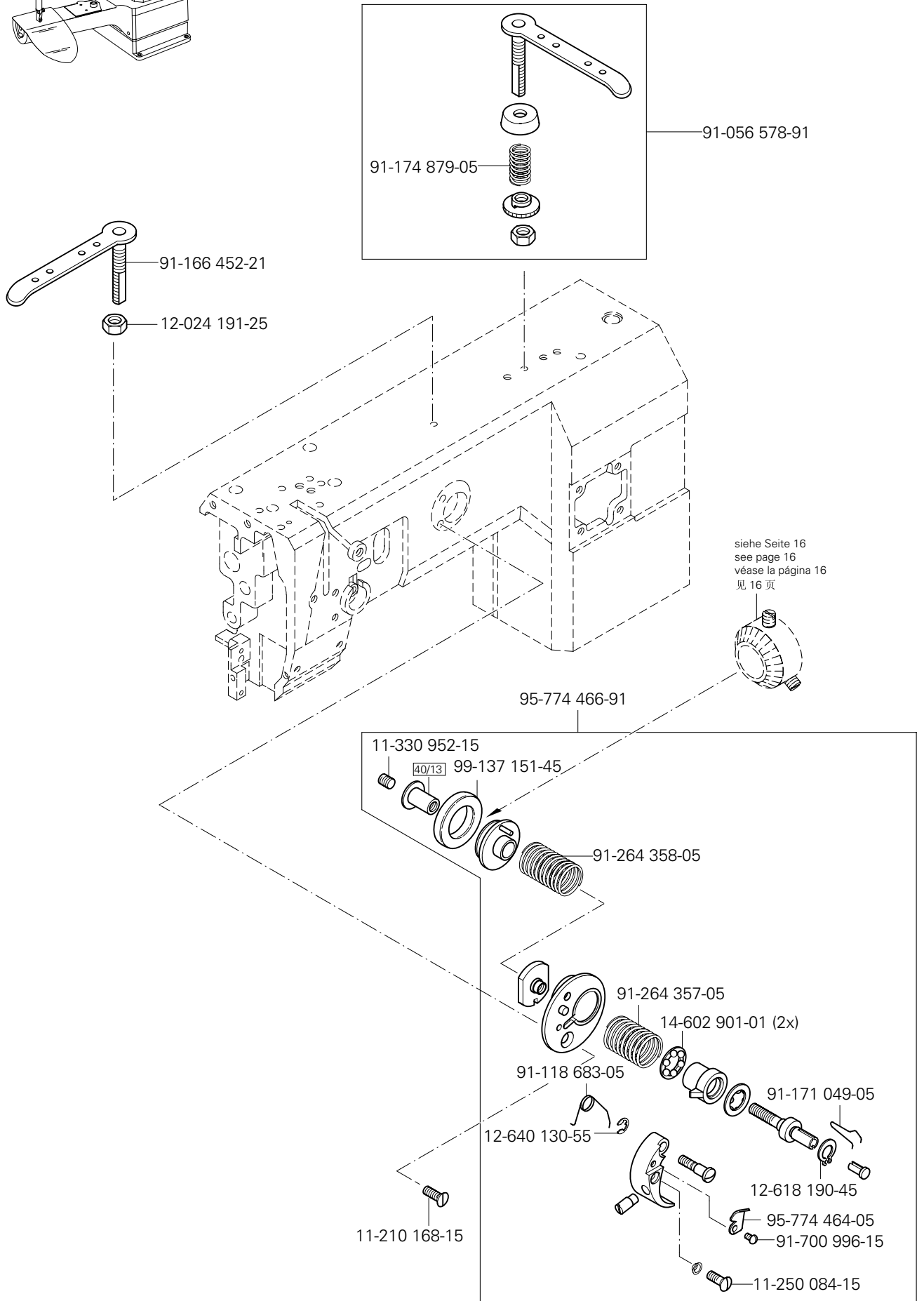

☐ siehe Kapitel 2 Erläuterung der Schlüsselzeichen
 see chapter 2 Explanation of key markings
 véase el Cap. 2 Explicaciones de los signos clave
 见第2章标记说明

3.04

Freiarmteile
Cylinder bed parts
Piezas del brazo al aire
悬臂零件

PFAFF 337

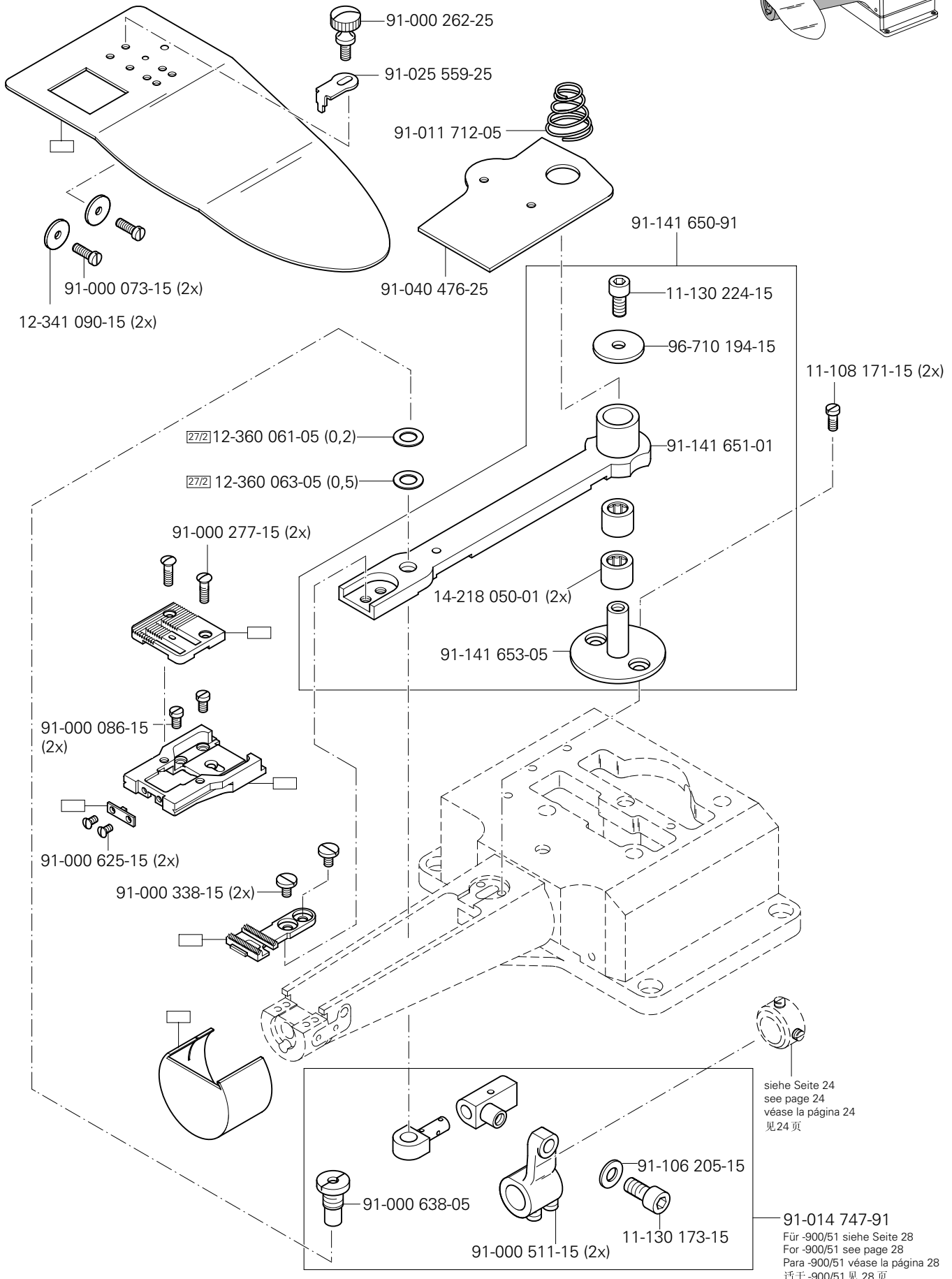
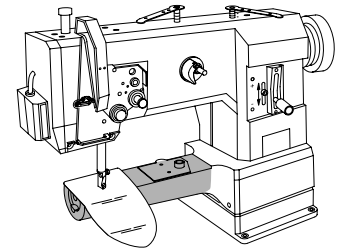

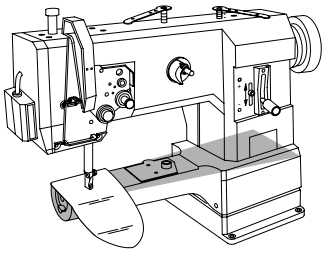

Freiarmteile
Cylinder bed parts
Piezas del brazo al aire
悬臂零件

PFAFF 337

3.04

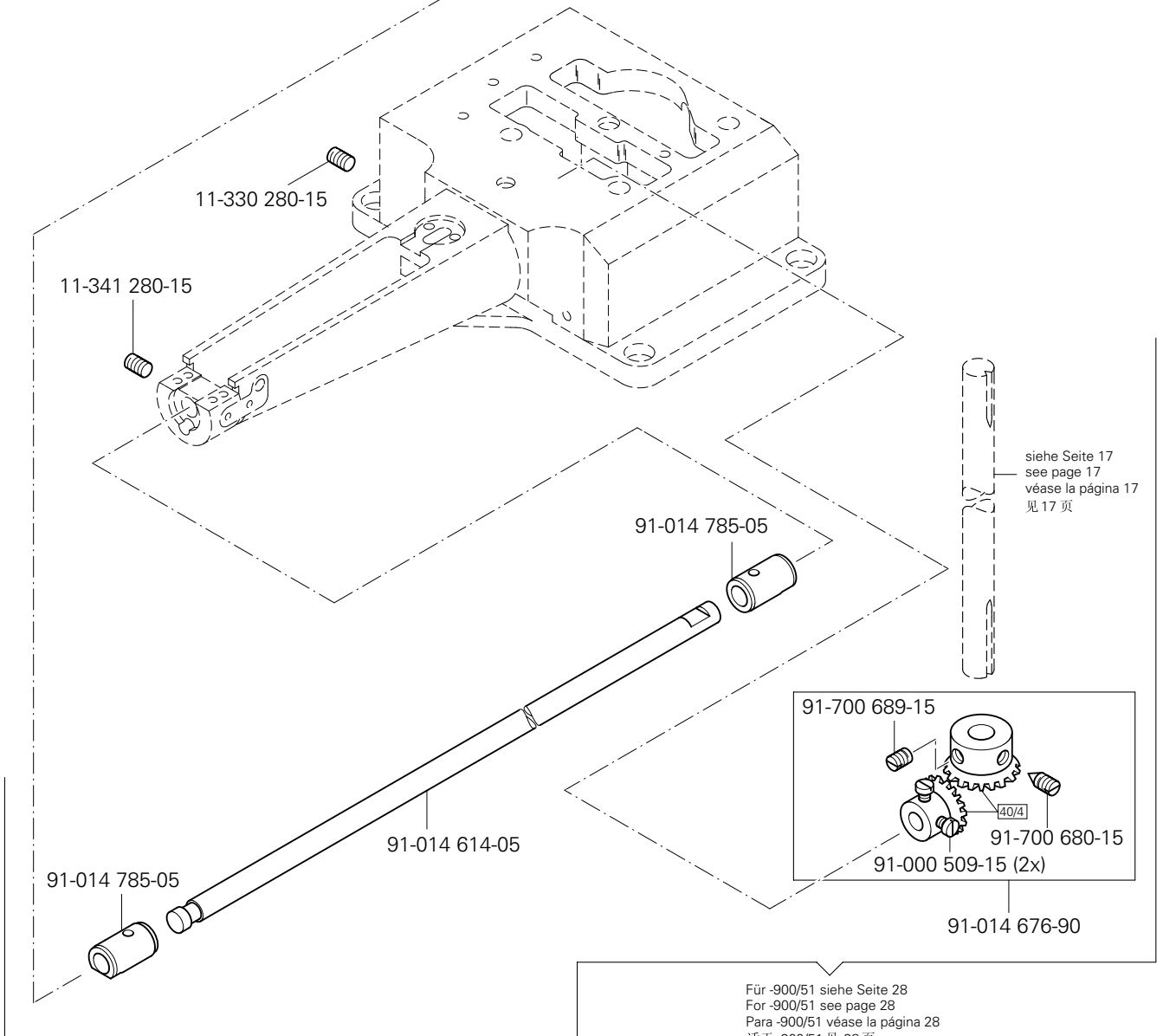
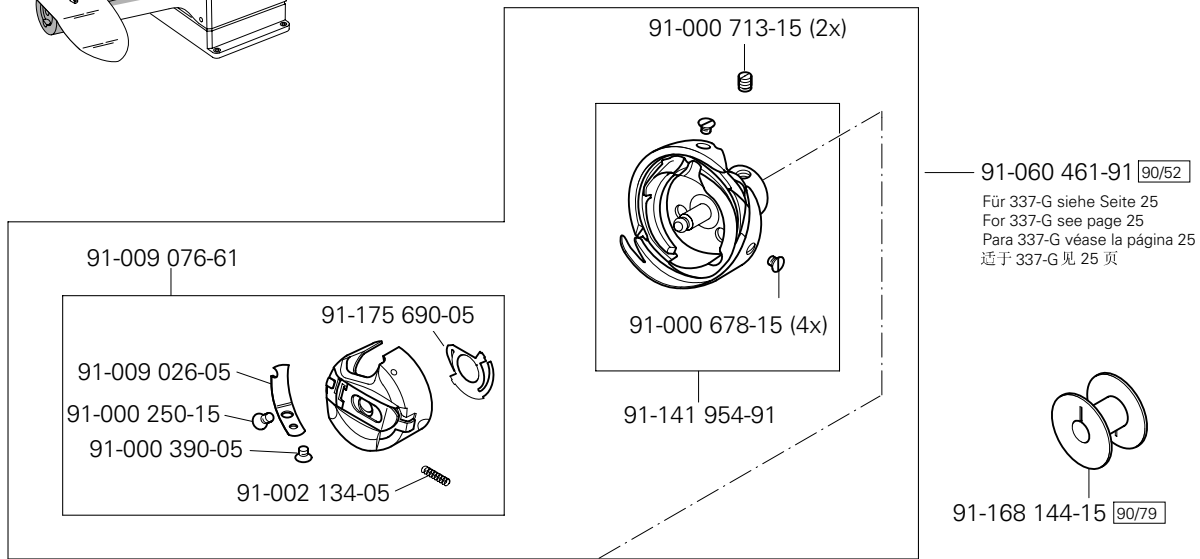

3.04

Freiarnteile
Cylinder bed parts
Piezas del brazo al aire
悬臂零件

PFAFF 337

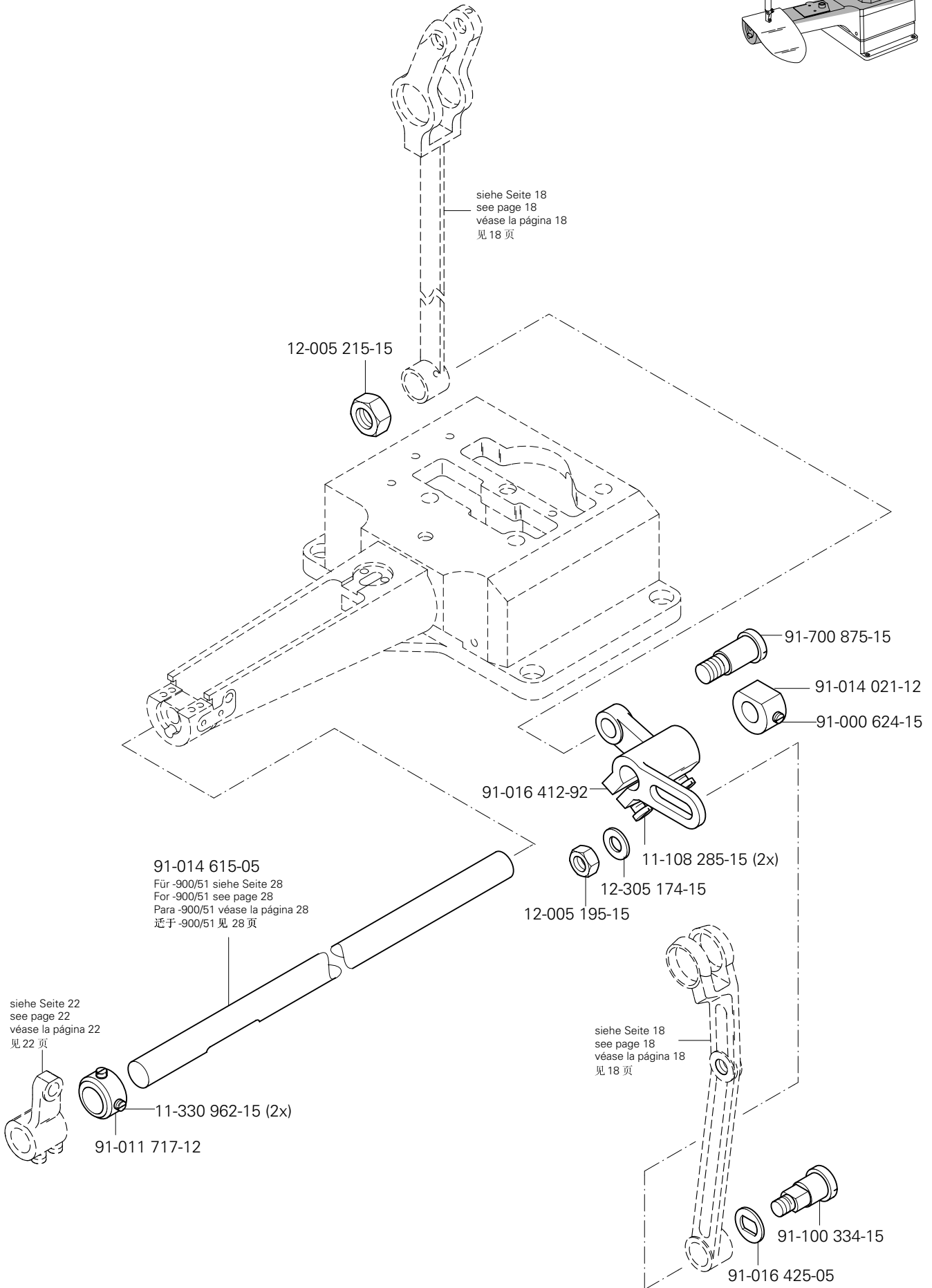
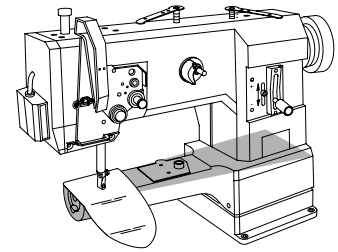

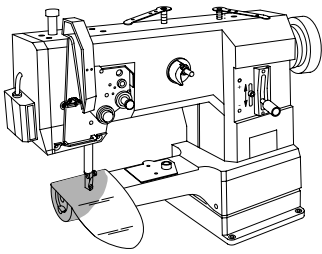

Abweichende Teile der PFAFF 337-G
 Different parts for PFAFF 337-G
 Piezas de la PFAFF 337-G que son diferentes
 PFAFF 337-G 中有差别的零件

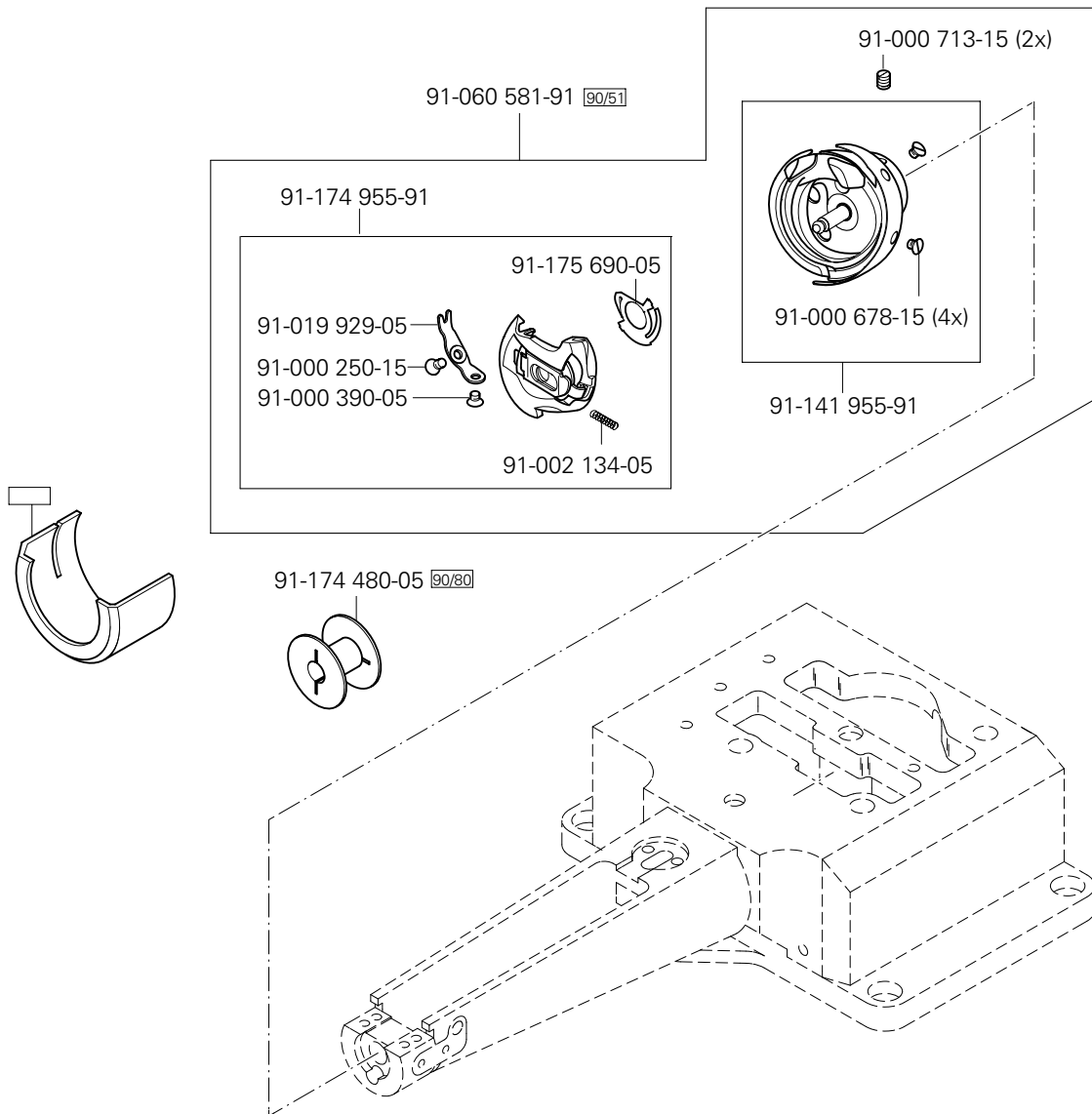

siehe Kapitel 2 Erläuterung der Schlüsselzeichen
 see chapter 2 Explanation of key markings
 véase el Cap. 2 Explicaciones de los signos clave
 见第2章标记说明

(die sonstigen Teile wie in Register 3.01 bis 3.04)
 (for all other parts see Sections 3.01 to 3.04)
 (las demás piezas como en los registros 3.01 al 3.04)
 (其它零件与3.01至3.04 章中的相同)

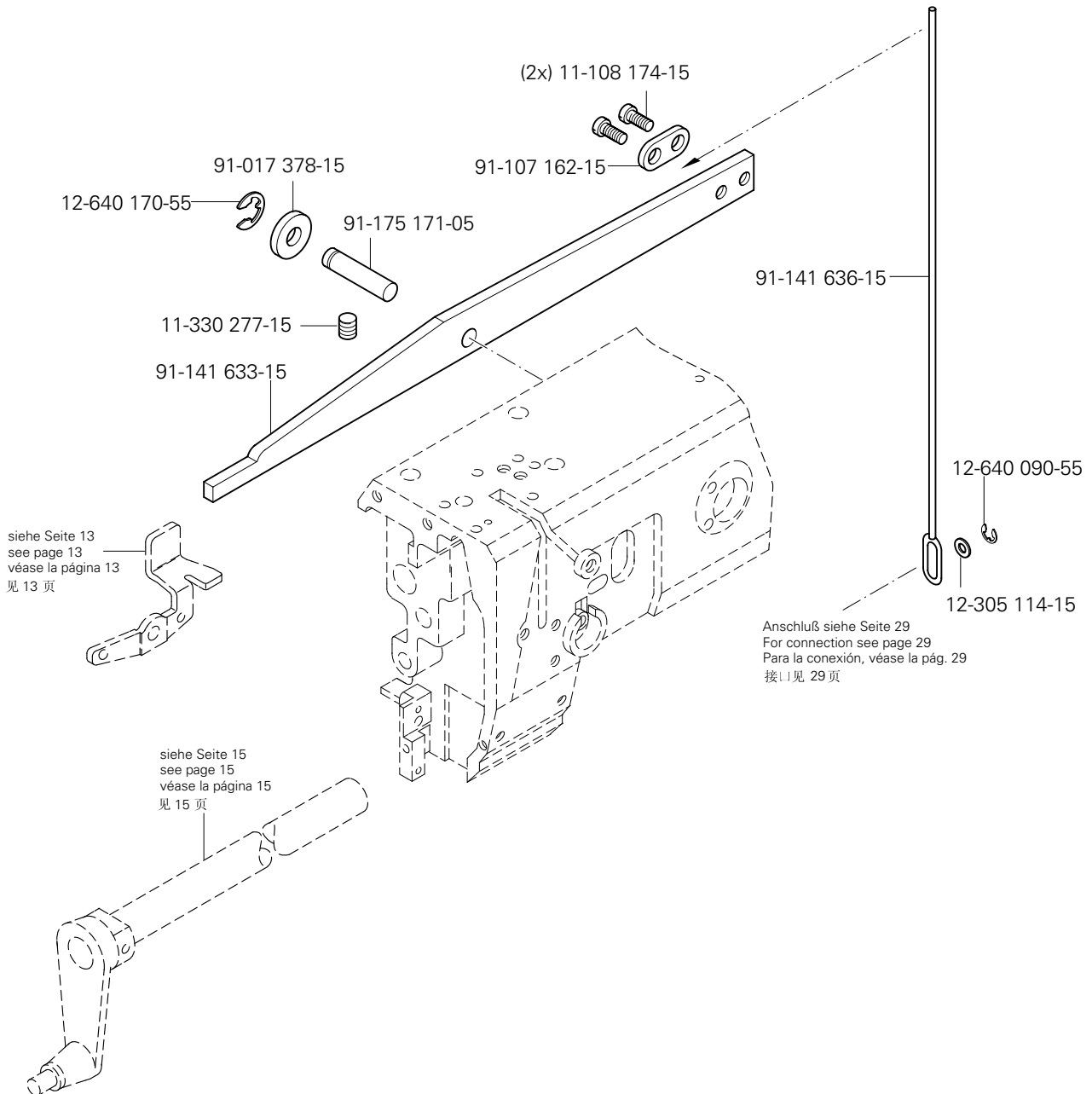
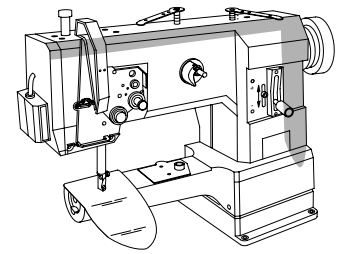

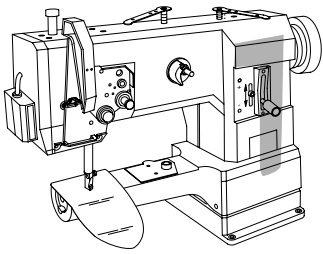

Fadenabschneid-Einrichtung (-900/51)
 Thread trimmer (-900/51)
 Cortahilos (-900/51)
 切线器 (-900/51)

PFAFF 337
 PFAFF 337-G

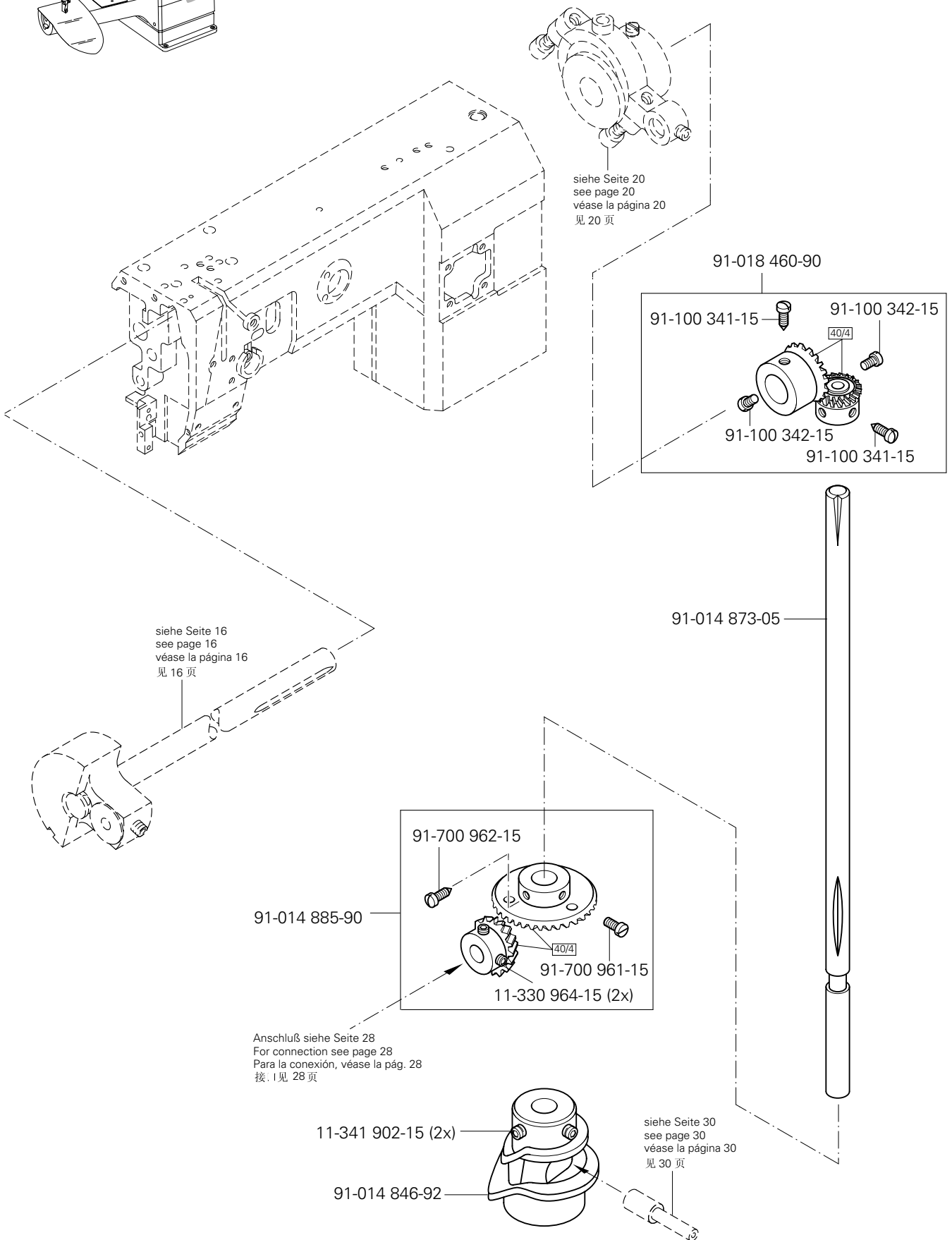

□ siehe Kapitel 2 Erläuterung der Schlüsselzeichen
 see chapter 2 Explanation of key markings
 véase el Cap. 2 Explicaciones de los signos clave
 见第2章标记说明

(die sonstigen Teile wie in Register 3.01 bis 3.04)
 (for all other parts see Sections 3.01 to 3.04)
 (las demás piezas como en los registros 3.01 al 3.04)
 (其它零件与3.01至3.04 章中的相同)

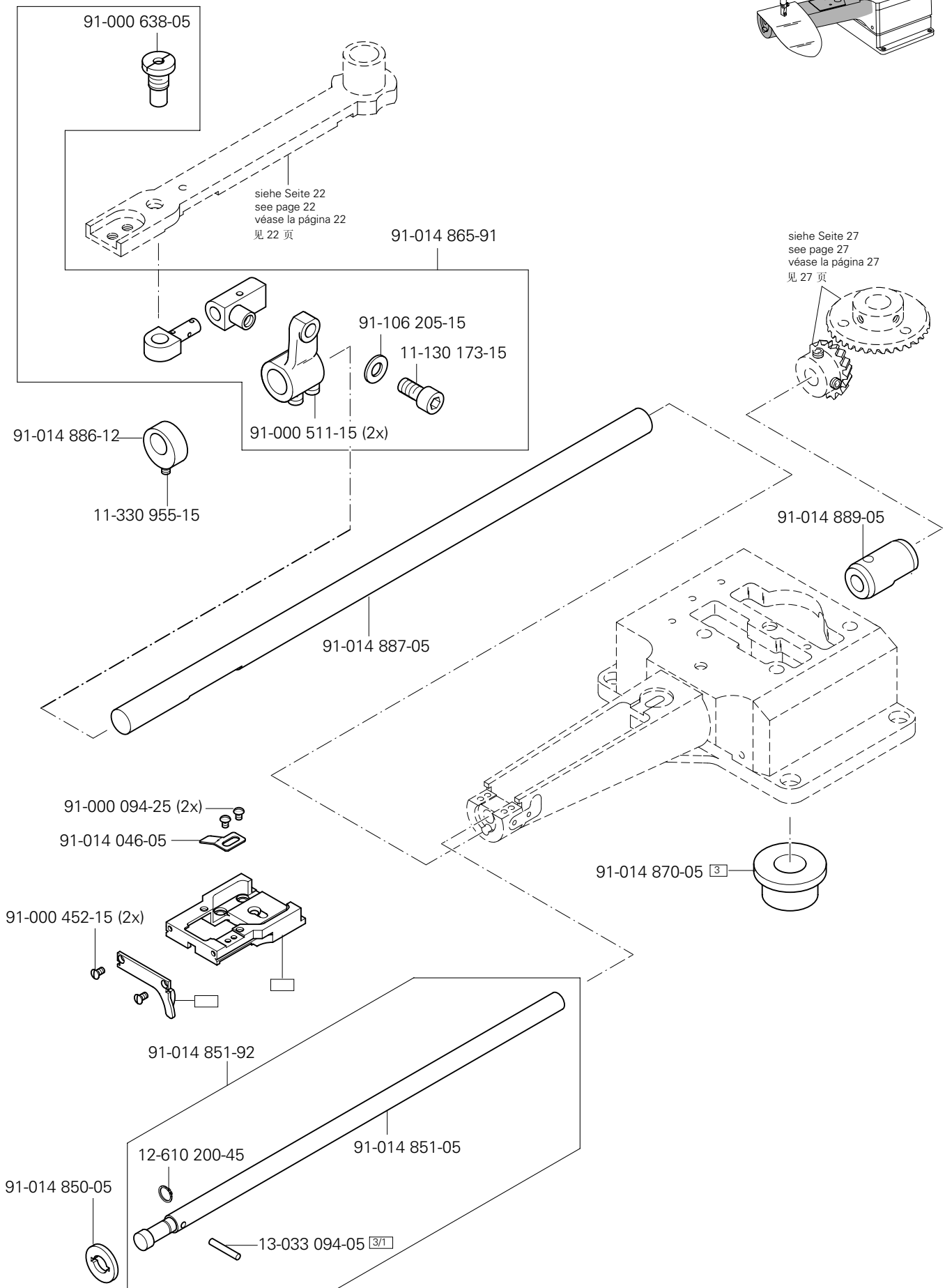
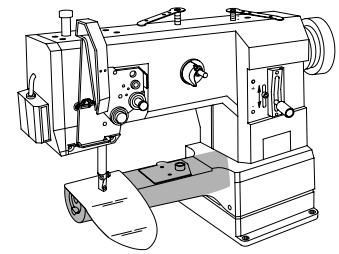

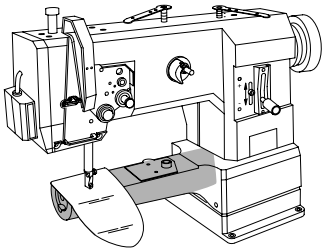

Fadenabschneid-Einrichtung (-900/51)
 Thread trimmer (-900/51)
 Cortahilos (-900/51)
 切线器 (-900/51)

PFAFF 337
 PFAFF 337-G

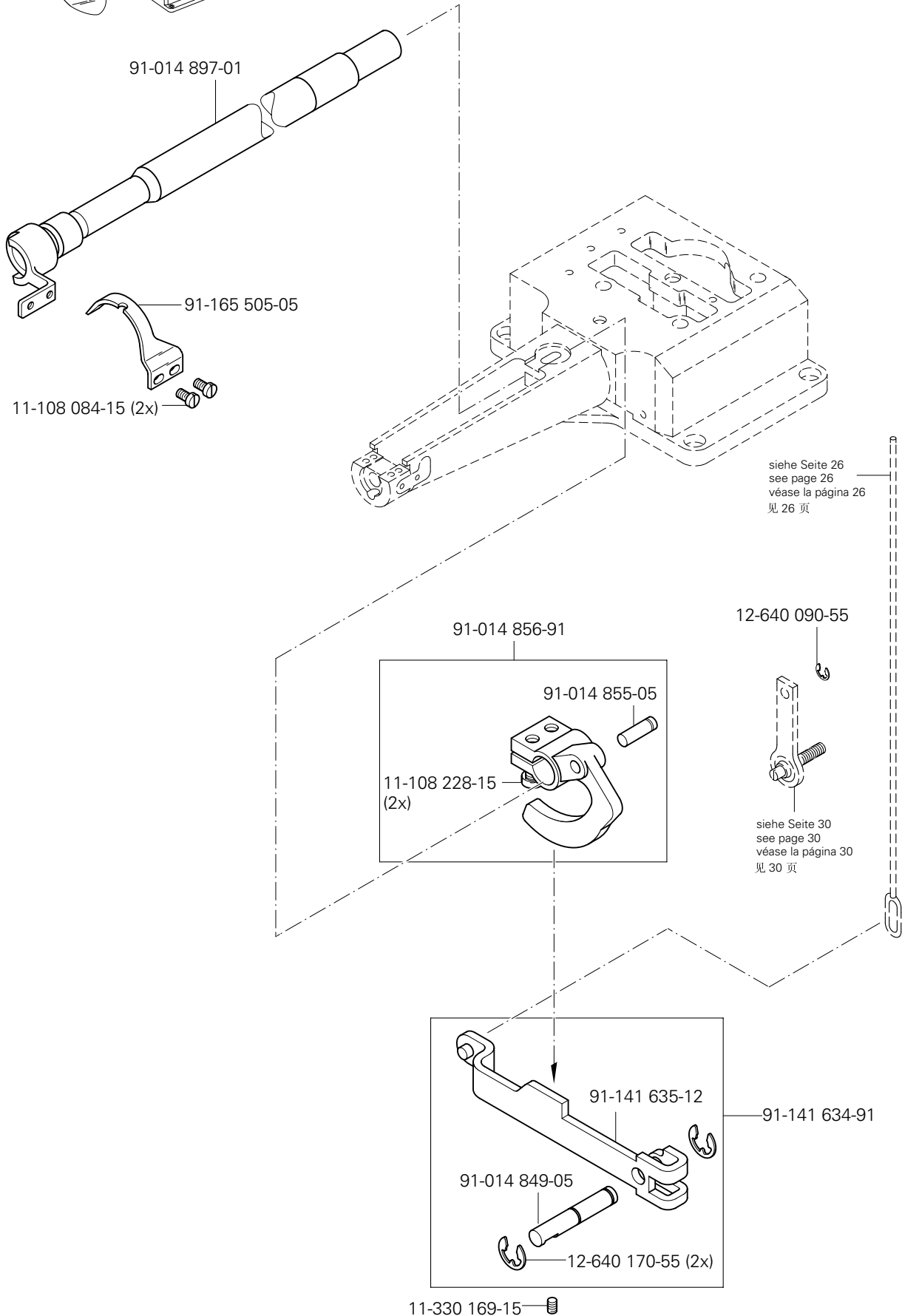

□ siehe Kapitel 2 Erläuterung der Schlüsselzeichen
 see chapter 2 Explanation of key markings
 véase el Cap. 2 Explicaciones de los signos clave
 见第2章标记说明

(die sonstigen Teile wie in Register 3.01 bis 3.04)
 (for all other parts see Sections 3.01 to 3.04)
 (las demás piezas como en los registros 3.01 al 3.04)
 (其它零件与3.01至3.04 章中的相同)

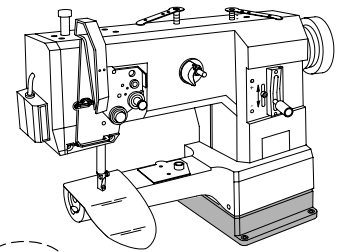

siehe Seite 27
 see page 27
 véase la página 27
 见 27 页

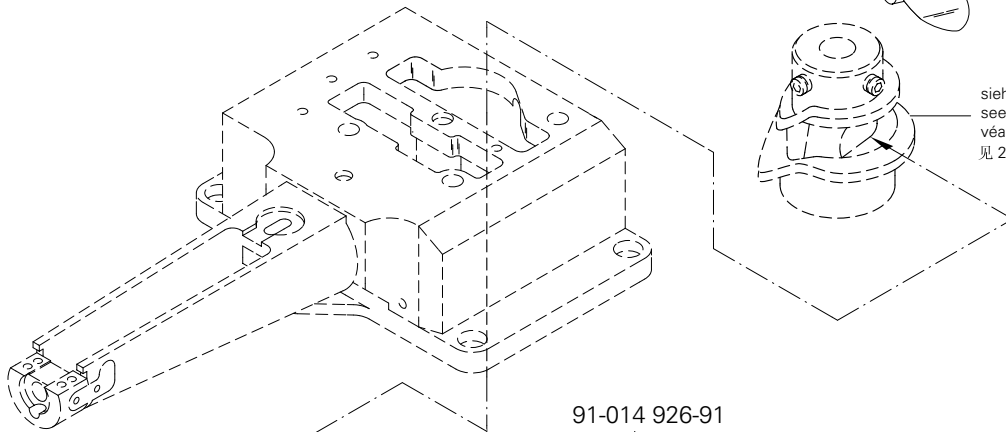

91-014 926-91

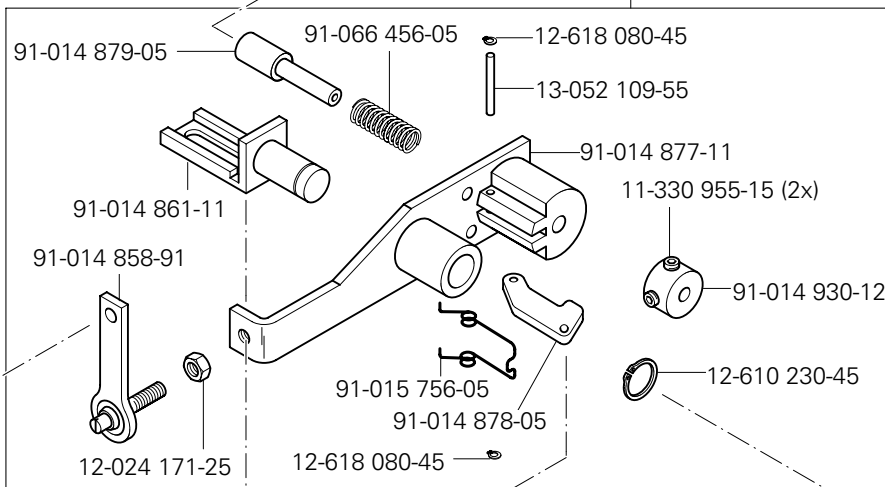

siehe Seite 29
 see page 29
 véase la página 29
 见 29 页

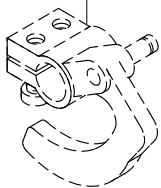

91-014 890-05

91-014 928-91

91-014 884-05

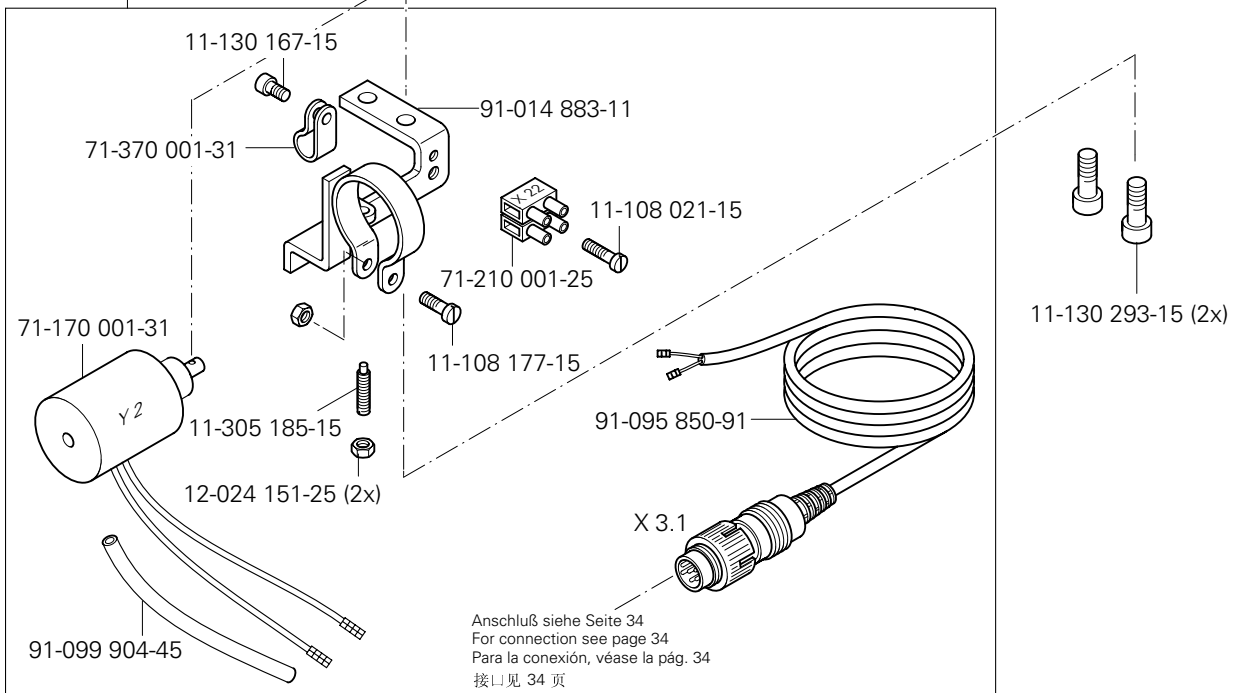

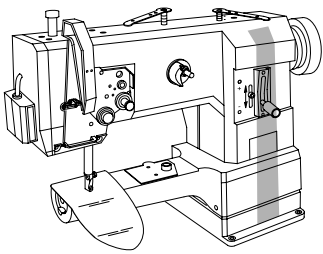

Presserfuß-Automatik (-910/98)
 Automatic presser lifter (-910/98)
 Alzaprensatelas (-910/98)
 压脚自动提升器 (-910/98)

PFAFF 337-900/51
 PFAFF 337-G-900/51

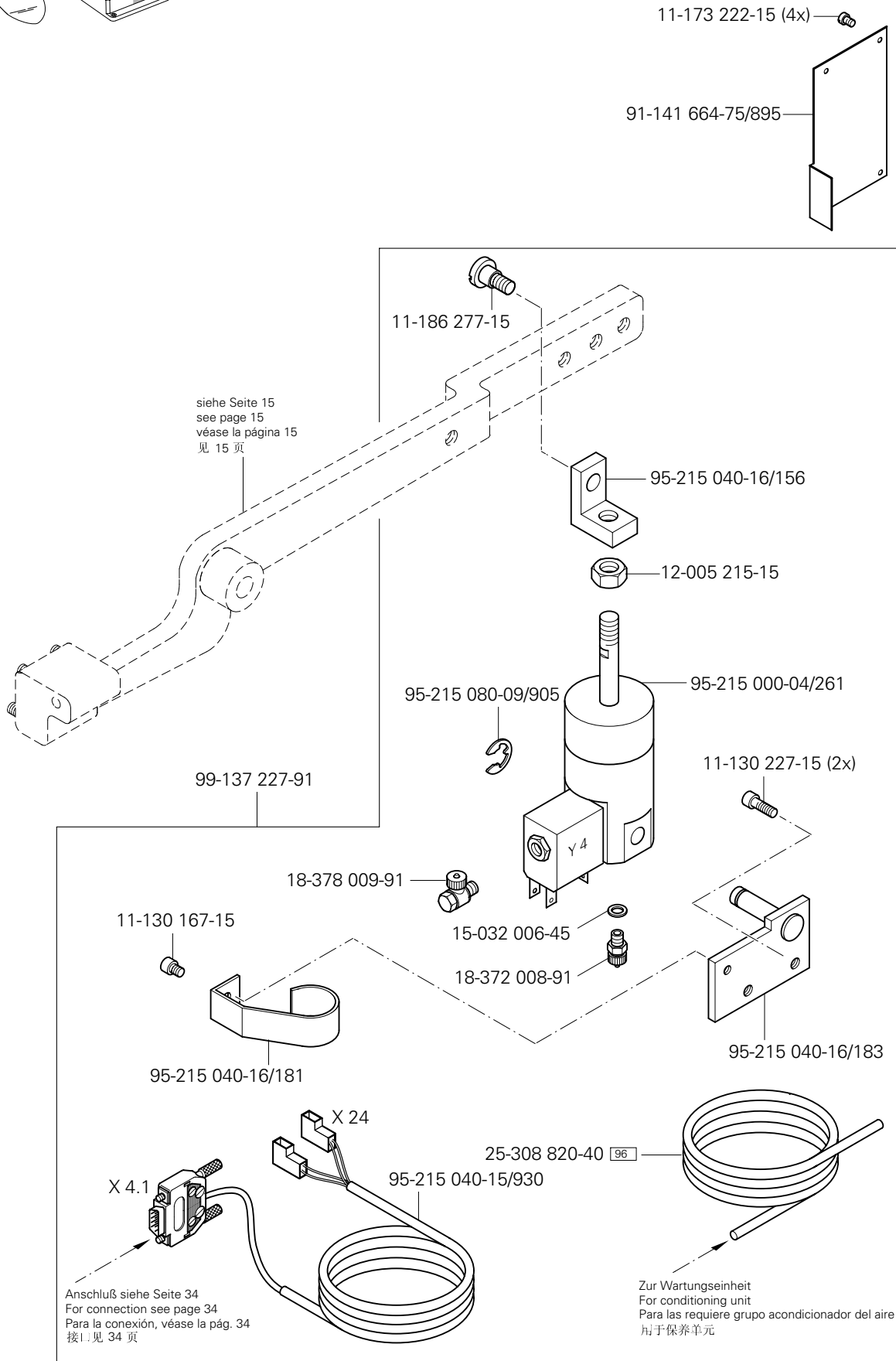

□ siehe Kapitel 2 Erläuterung der Schlüsselzeichen
 see chapter 2 Explanation of key markings
 véase el Cap. 2 Explicaciones de los signos clave
 见第2章标记说明

(die sonstigen Teile wie in Register 3.01 bis 3.04)
 (for all other parts see Sections 3.01 to 3.04)
 (las demás piezas como en los registros 3.01 al 3.04)
 (其它零件与3.01至3.04 章中的相同)

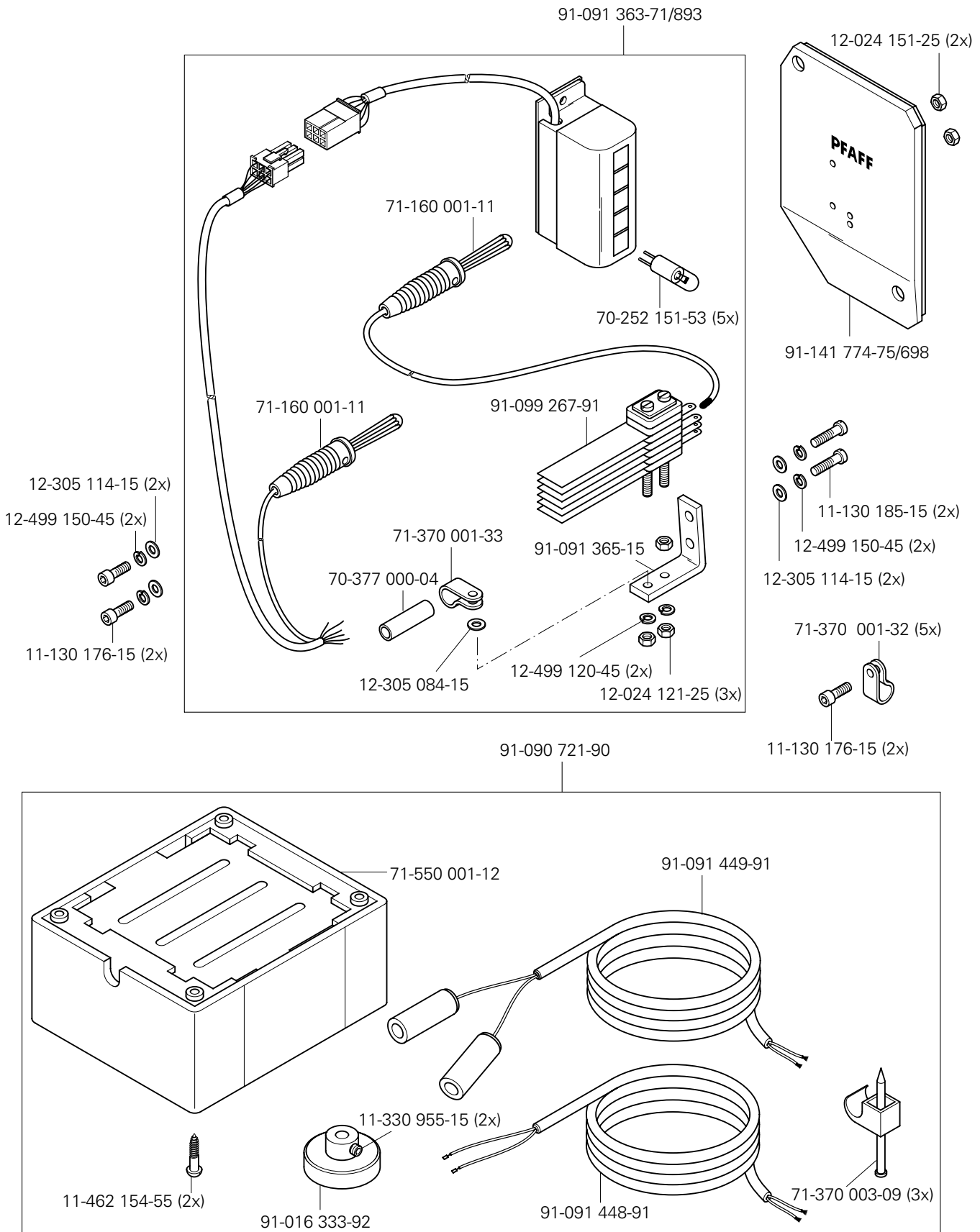
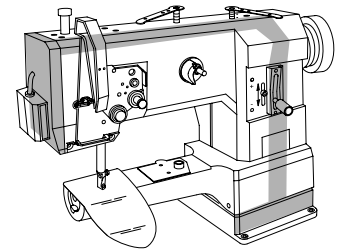

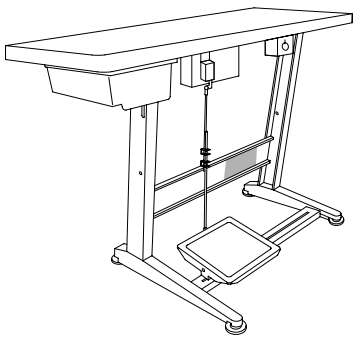

Wartungseinheit
 Air filter / lubricator
 Grupo acondicionador del aire comprimido
 保养单元

PFAFF 337
 PFAFF 337-G

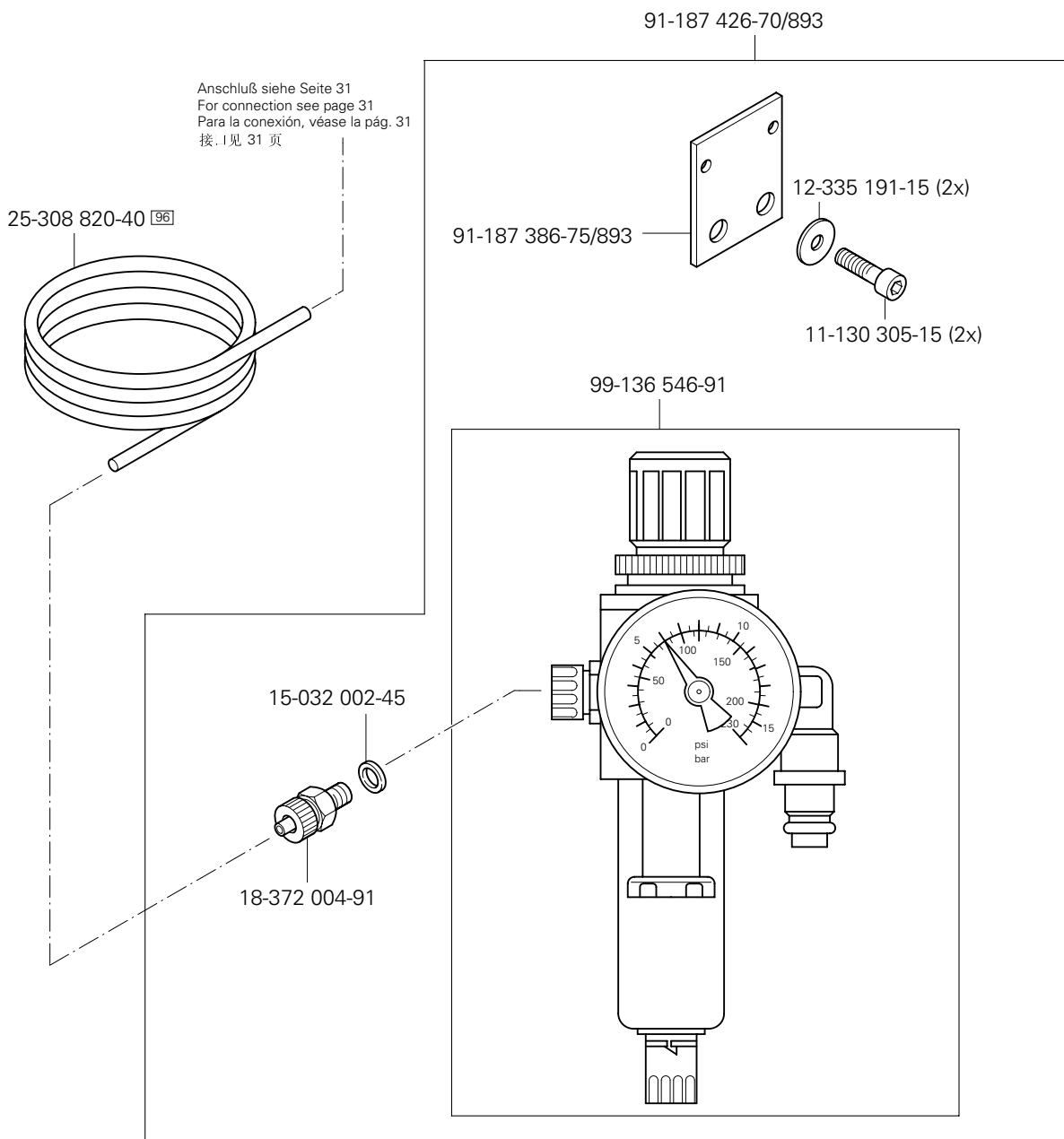

☐ siehe Kapitel 2 Erläuterung der Schlüsselzeichen
 see chapter 2 Explanation of key markings
 véase el Cap. 2 Explicaciones de los signos clave
 见第2章标记说明

(die sonstigen Teile wie in Register 3.01 bis 3.04)
 (for all other parts see Sections 3.01 to 3.04)
 (las demás piezas como en los registros 3.01 al 3.04)
 (其它零件与3.01至3.04 章中的相同)

9.01

Kabelbaum zum Oberteil
 Cable tree to sewing head
 Mazo de cables para el cabezal
 上部机器电缆束

PFAFF 337
 PFAFF 337-G

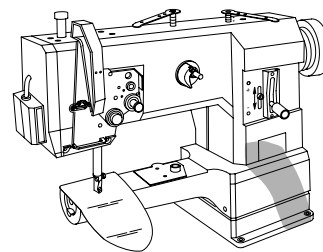

Anschluß siehe Seite 39
 For connection see page 39
 Para la conexión, véase la pág. 39
 接口见 39 页

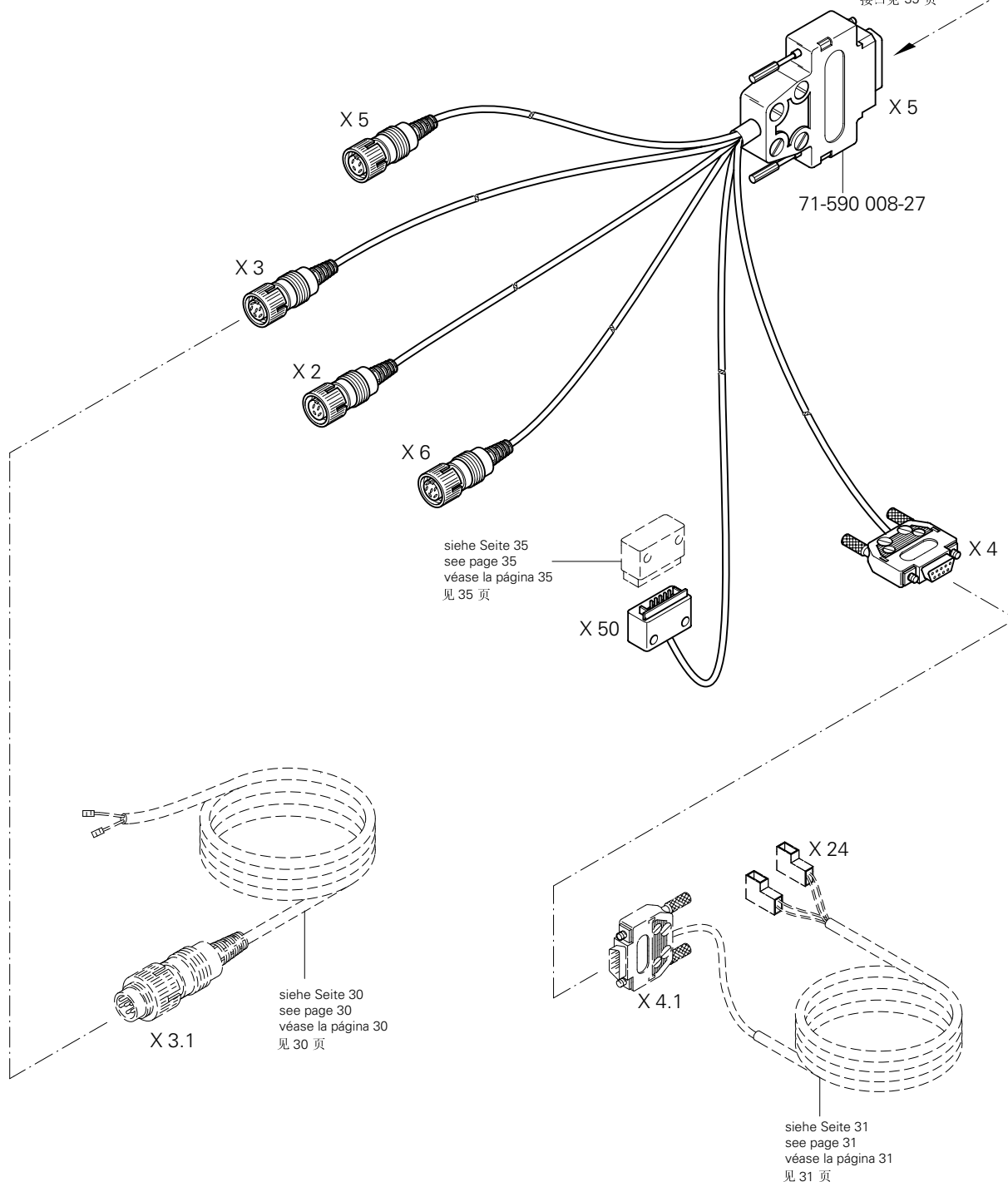

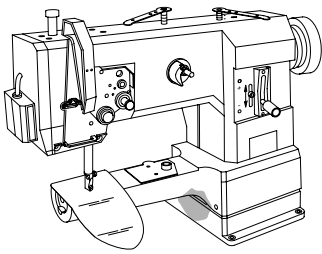

Oberteilerkennung
Sewing head identification
Detección de la parte superior
机头识别

PFAFF 337
PFAFF 337-G

9.02

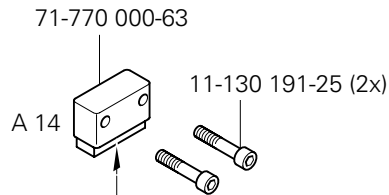

Anschluß siehe Seite 34
For connection see page 34
Para la conexión, véase la pág. 34
接口见 34 页

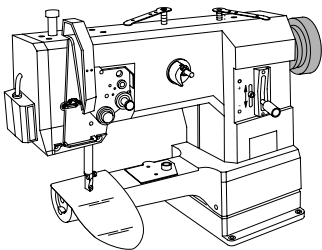
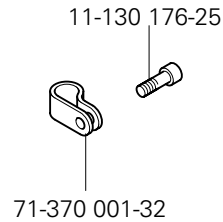

Positionsgeber
Synchronizer
Sincronizador
位置传感器

PFAFF 337
PFAFF 337-G

9.03

71-590 007-32 (Quick PD3)

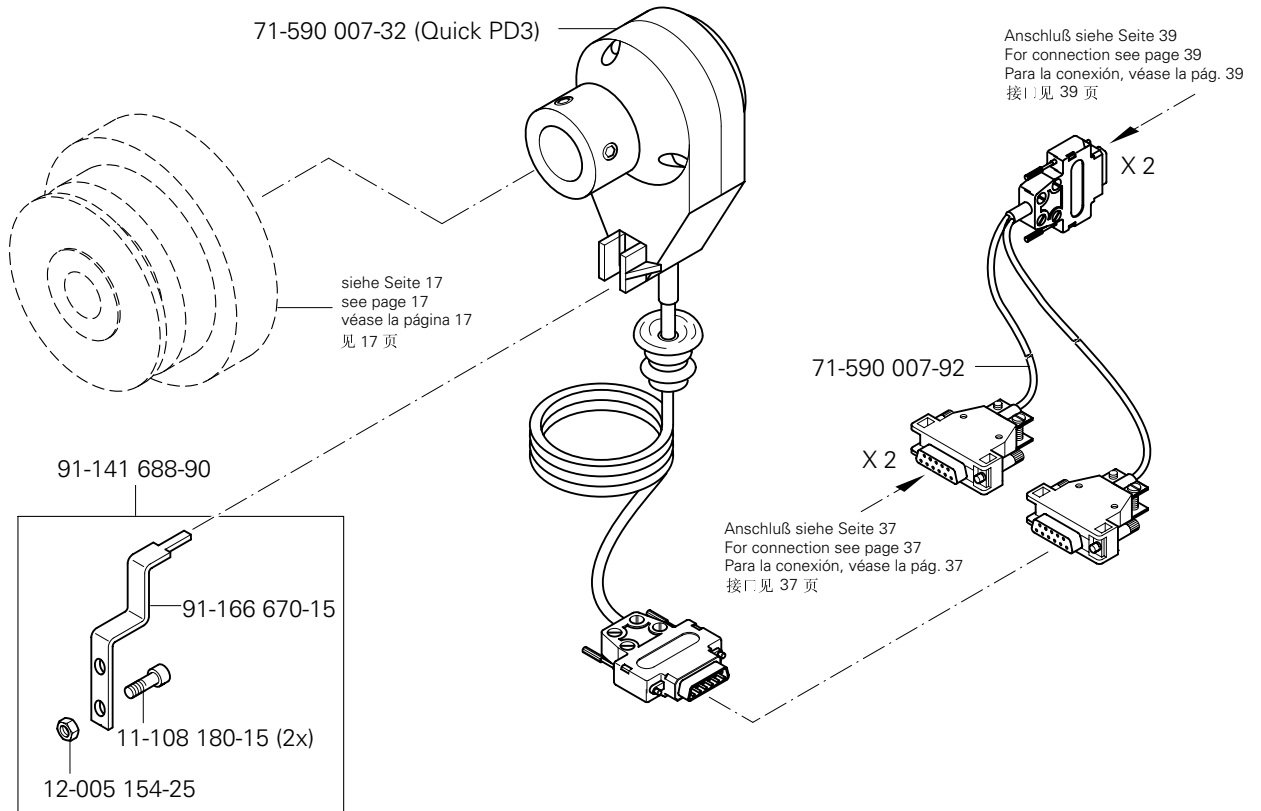

siehe Seite 17
see page 17
véase la página 17
见 17 页

Anschluß siehe Seite 39
For connection see page 39
Para la conexión, véase la pág. 39
接口见 39 页

Anschluß siehe Seite 37
For connection see page 37
Para la conexión, véase la pág. 37
接口见 37 页

9.04

Bedienfeld
Control panel
Panel de mandos
操作板

PFAFF 337
PFAFF 337-G

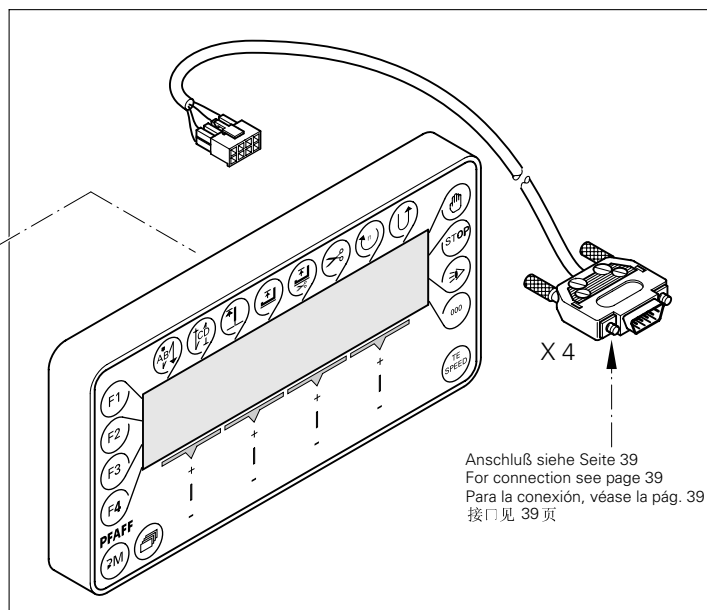
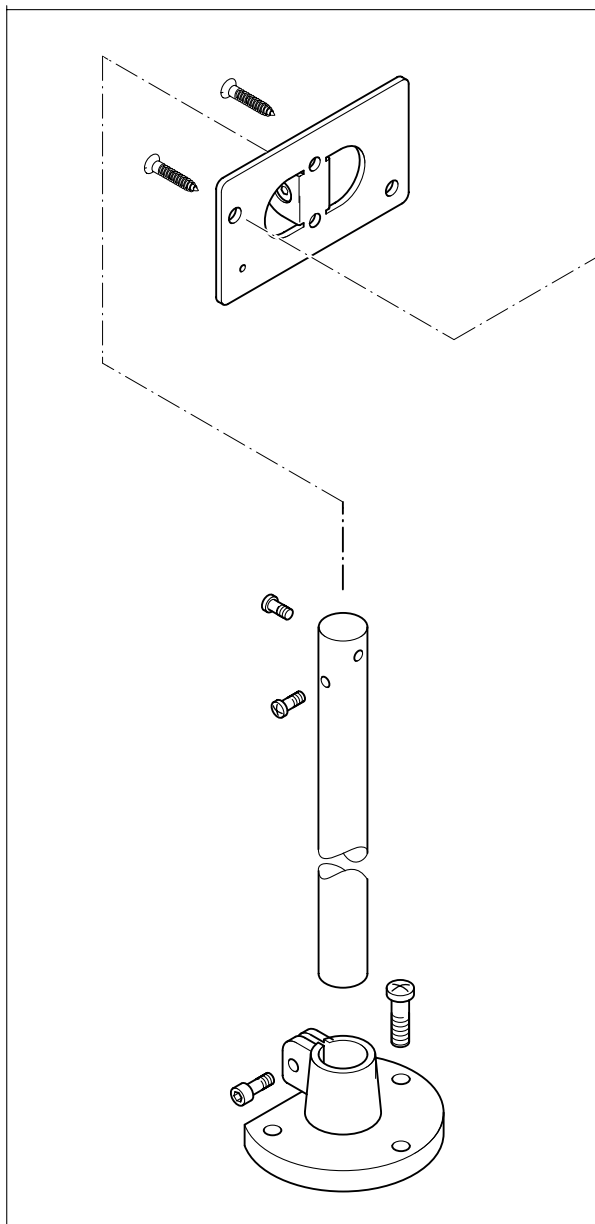
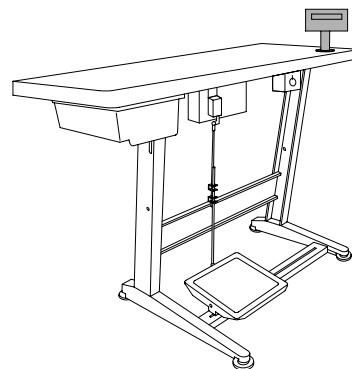

71-590 007-77

71-590 008-28

Anbausatz für externen Motor
 Mounting kit for external motor
 Juego de piezas acoplables motor externo
 用于外部电机的安装组件

PFAFF 337
 PFAFF 337-G

9.05

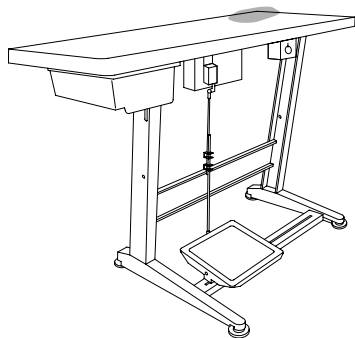

siehe Seite 17
 see page 17
 véase la página 17
 见 17 页

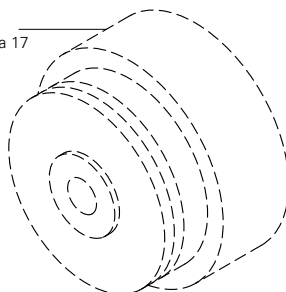

16-414 141-05

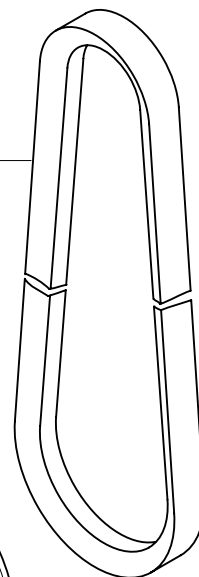

91-290 576-91

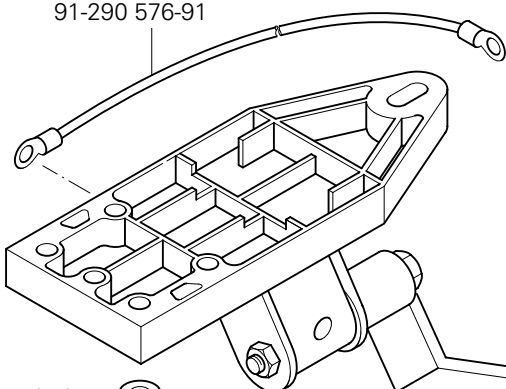

Zum Gestell
 For stand
 Para el bancada
 用于机架

12-335 210-15 (3x)

11-039 378-15 (3x)

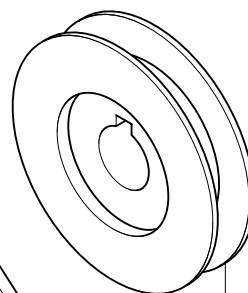
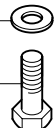

71-520 006-05

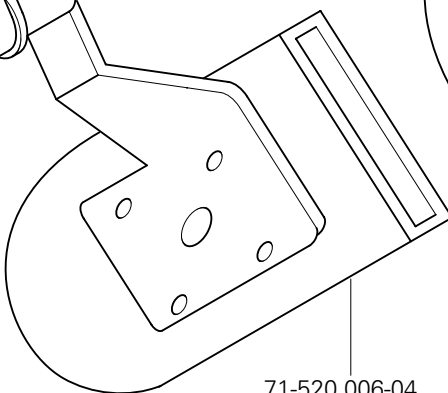

71-520 006-04

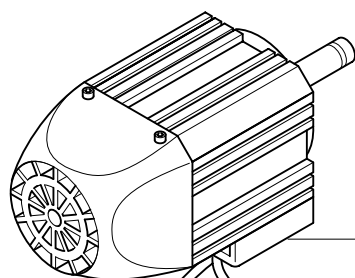

71-520 006-02

X 1

X 2

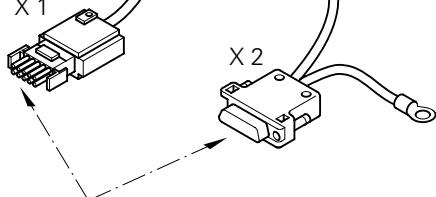

Anschluß siehe Seite 39
 For connection see page 39
 Para la conexión, véase la pág. 39
 接口见 39 页

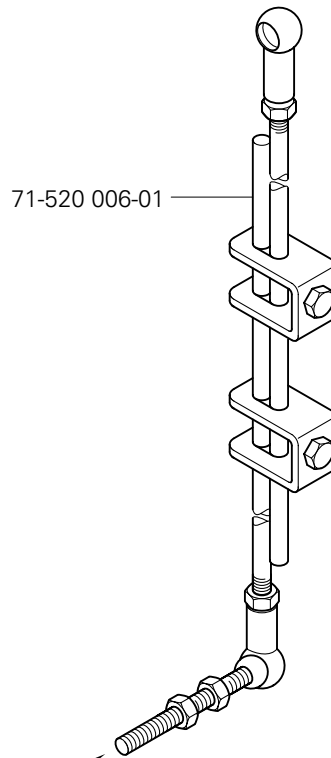
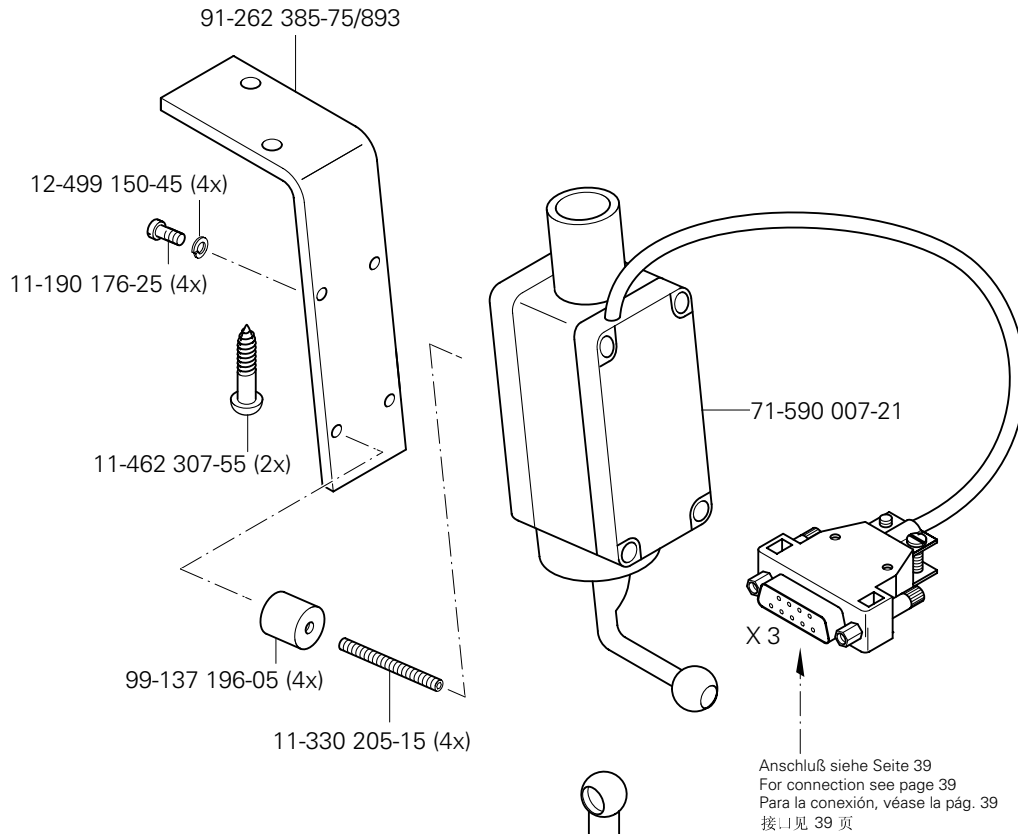
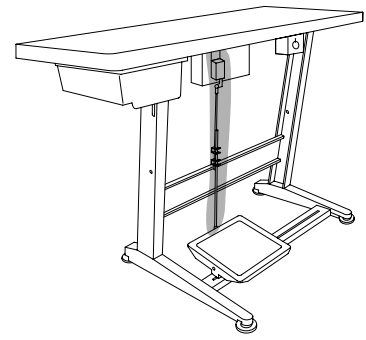

Zur Tretplatte
For the pedal
Para el pedal
用于踏板

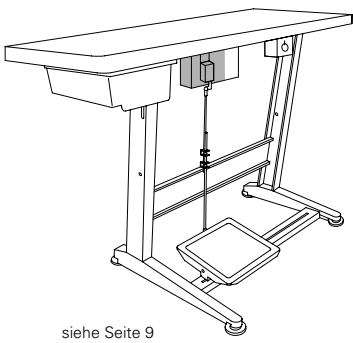

Steuerkasten
Control box
Caja de mandos
控制箱

PFAFF 337
PFAFF 337-G

9.07

siehe Seite 9
see page 9
véase la página 9
见 9 页

91-291 899-91

siehe Seite 37
see page 37
véase la página 37
见 37 页

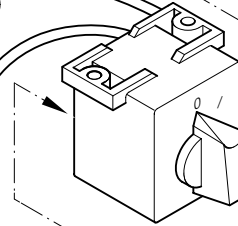
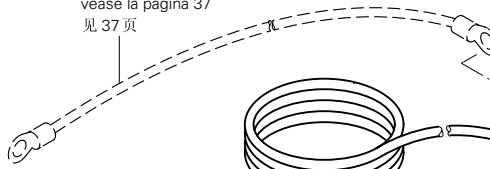
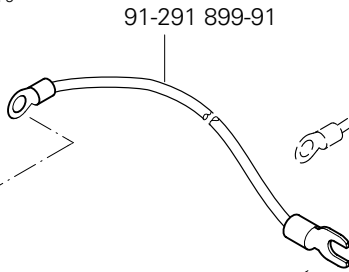
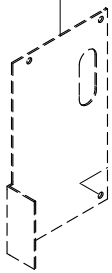

11-130 287-25

siehe Seite 37
see page 37
véase la página 37
见 37 页

X 1

71-590 007-82

siehe Seite 35 und 37
see page 35 and 37
véase la página 35 y 37
见 35 和 37 页

X 2

siehe Seite 38
see page 38
véase la página 38
见 38 页

X 3

siehe Seite 36
see page 36
véase la página 36
见 36 页

X 4

siehe Seite 34
see page 34
véase la página 34
见 34 页

X 5

11-462 403-55
(4x)

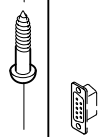

91-291 899-91

Zum Gestell
For stand
Para el bancada
用于机架

11-130 287-25

12-305 174-25 (2x)

91-291 458-91

9.08

Motor-Hauptschalter
Main switch
Interruptor principal
电机主开关

PFAFF 337
PFAFF 337-G

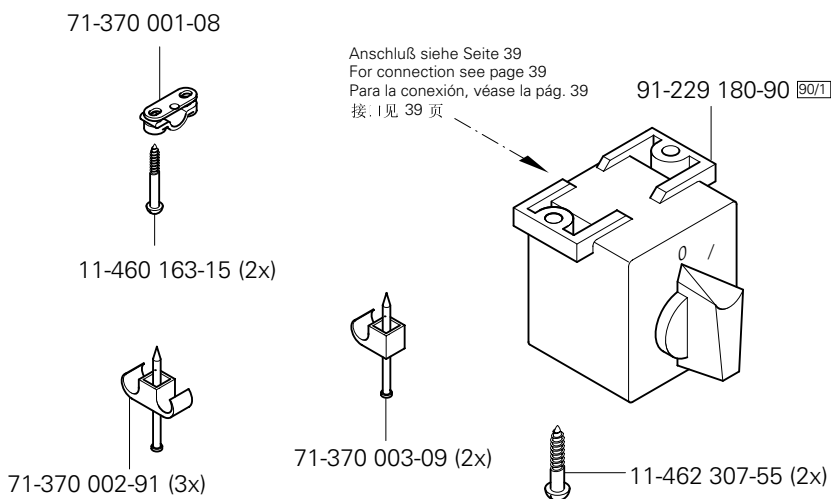
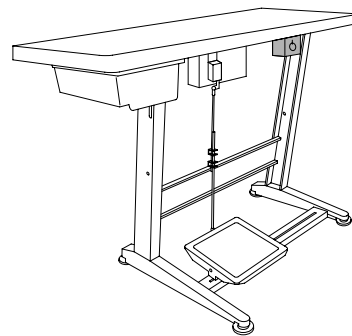

91-229 070-70/895

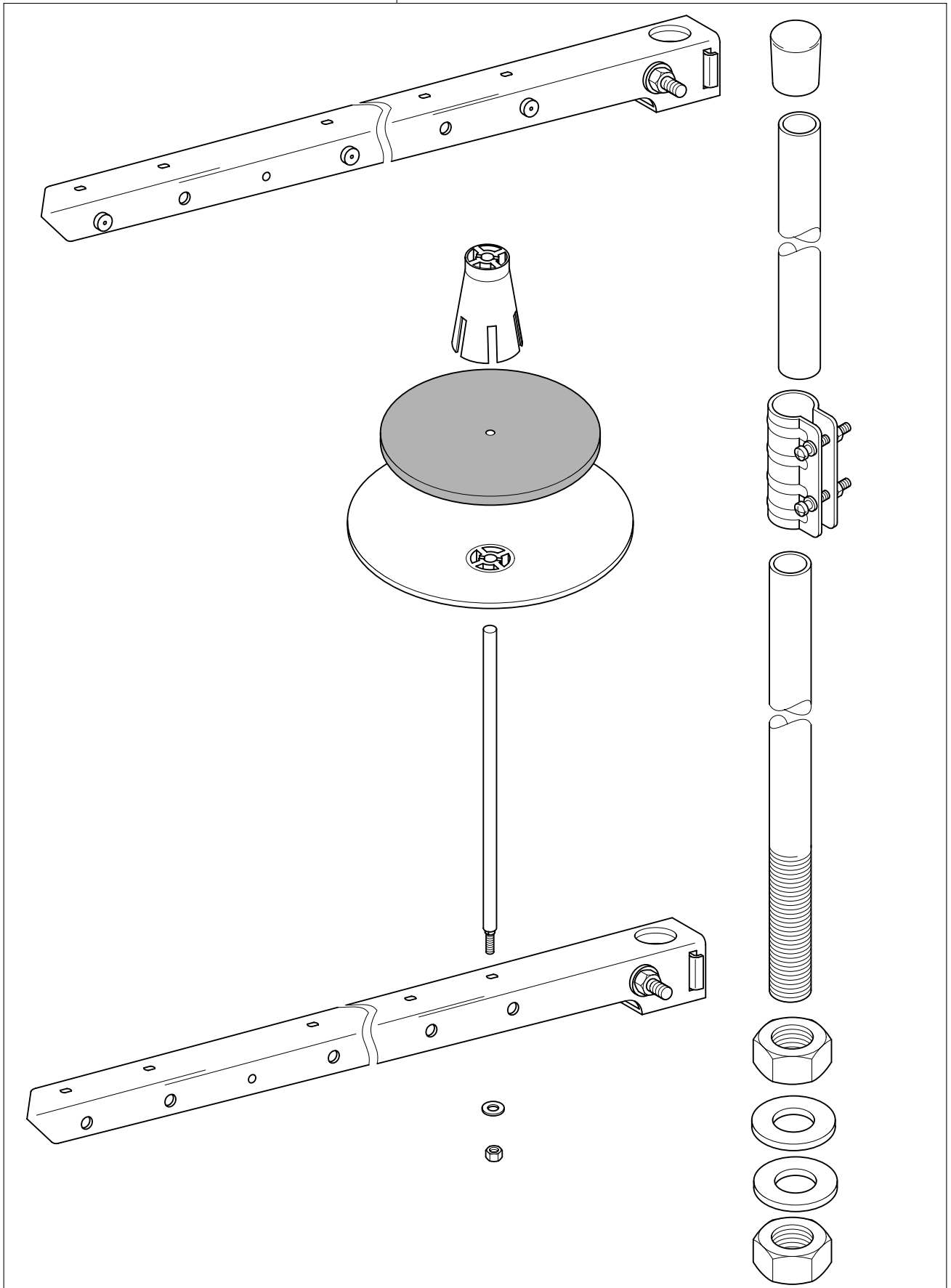

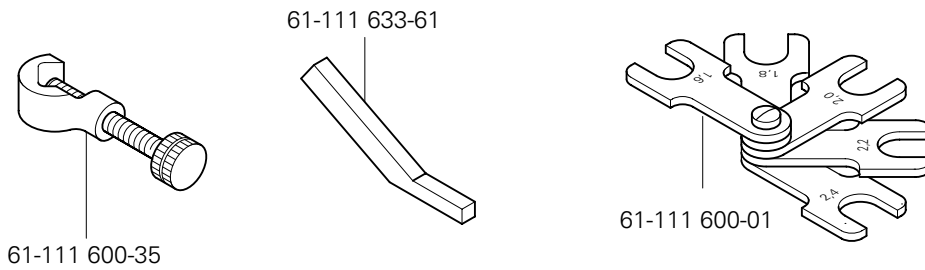

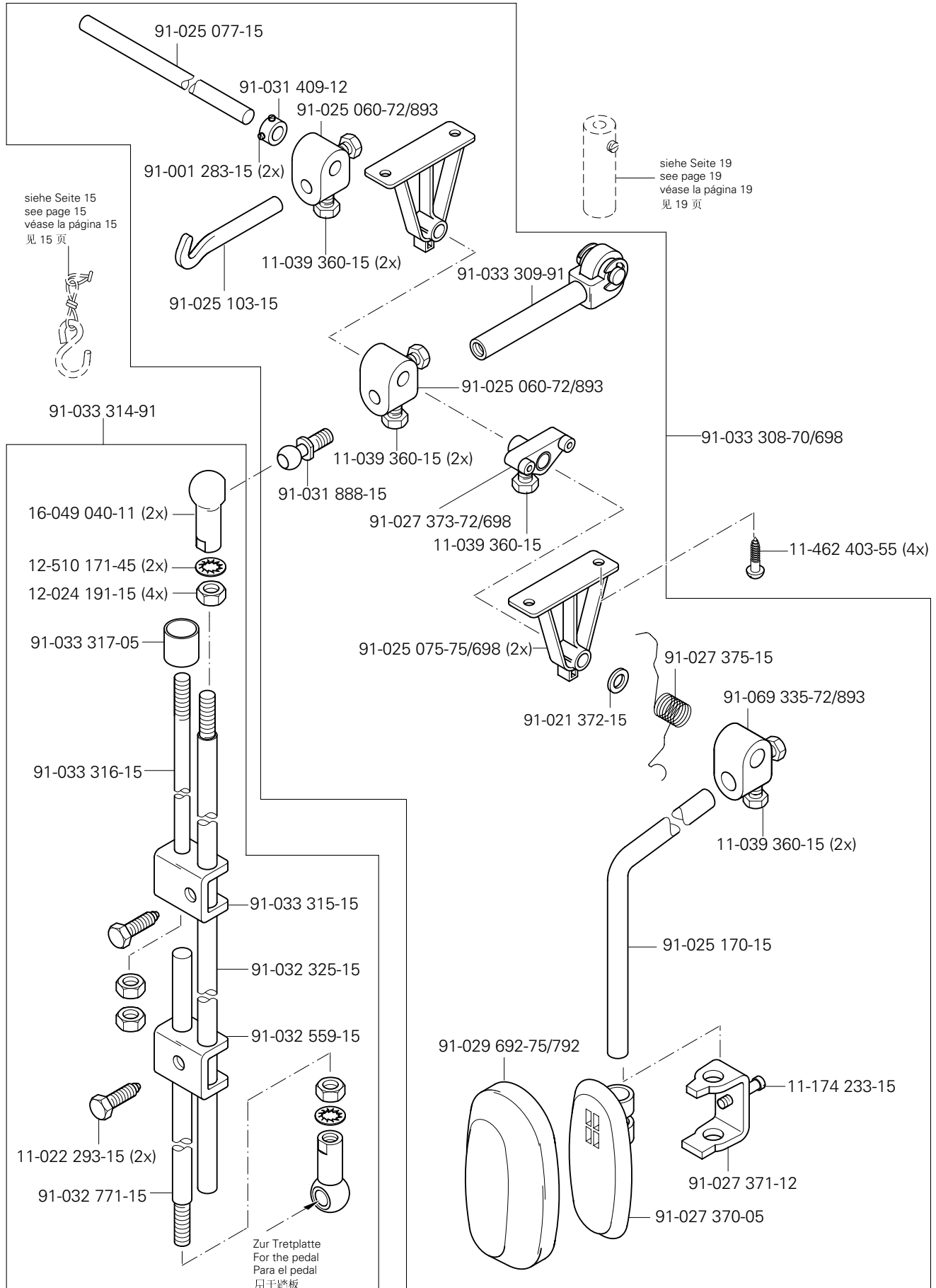

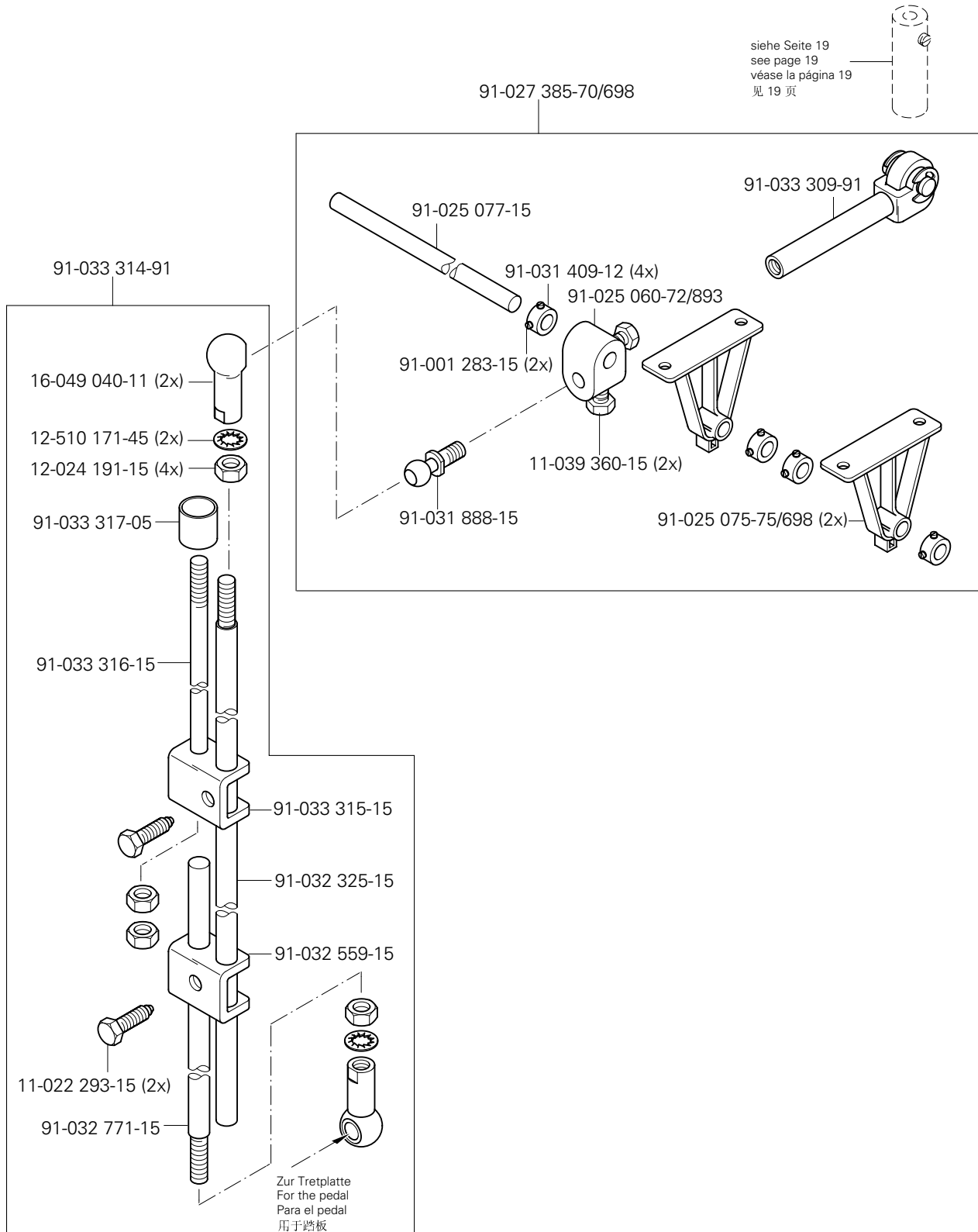

Öl Oil Aceite 油	Mittelpunkts-Viskosität bei: Mean viscosity at: Viscosidad media a: 中点粘度:		Dichte bei: Density of: Densidad a: 密度, 在:		Bestellnummer für Behälter mit: Part number for can with: Número de pedido para recipientes con: 订货号用于油箱, 带:		
	°C	mm ² /s	°C	g/cm ³ (g/ml)	1 Liter 1 Litro 1 升		
28-011 201-44	40	22,0	15	0,865	91-129 917-91		

Fett Grease Grasa 脂	Penetration Penetration Penetración 贯入度	Tropfpunkt Drip-point Punto de goteo 滴点	Bestellnummer für Behälter mit: Part number for can with: Número de pedido para recipientes con: 订货号用于油箱, 带:				
			mm/10	°C	0,25 kg	0,5 kg	1 kg
28-011 202-05							28-011 202-05
28-011 202-43	375-405	150				28-011 202-43	
28-011 202-47	220-250	185					28-011 202-47

Reinigungsmittel Cleansing agent Limpiadores 清洁剂	Bestellnummer für Behälter mit: Part number for can with: Número de pedido para recipientes con: 订货号用于油箱, 带:		
	240 ml		
Isopropyl-Alkohol / 异丙醇	95-665 735-91		

No. 零件号	Seite Page Página 页号	No. 零件号	Seite Page Página 页号	No. 零件号	Seite Page Página 页号	No. 零件号	Seite Page Página 页号
11-022 293-15	43, 44	11-130 955-15	20	11-341 901-15	17	12-610 190-45	10
11-039 222-15	14	11-132 286-15	9	11-341 902-15	17, 27	12-610 200-45	10, 28
11-039 225-15	14	11-173 171-75	9	11-460 163-15	40	12-610 230-45	30
11-039 360-15	43, 44	11-173 177-25	13	11-462 154-55	32	12-618 080-45	30
11-039 378-15	37	11-173 222-15	9, 31	11-462 247-55	9	12-618 190-45	21
11-108 021-15	30	11-174 173-15	10	11-462 307-55	38, 40	12-618 230-45	19
11-108 084-15	29	11-174 233-15	13, 43	11-462 403-55	39, 43	12-640 090-55	26, 29
11-108 171-15	11, 22	11-186 277-15	31	11-721 482-15	17	12-640 130-55	21
11-108 174-15	11, 26	11-190 176-25	38	12-005 154-25	11, 35	12-640 170-55	13, 26, 29
11-108 177-15	11, 30	11-210 165-15	13	12-005 195-15	20, 24	12-640 230-55	15
11-108 177-25	12	11-210 168-15	11, 21	12-005 215-15	24, 31	13-033 094-05	28
11-108 180-15	35	11-210 273-15	17	12-024 121-25	32	13-052 109-55	30
11-108 222-15	11	11-225 172-15	11	12-024 151-25	11, 30, 32	13-064 383-05	13, 20
11-108 228-15	10, 14, 29	11-250 076-25	20	12-024 171-25	30	13-065 319-05	18
11-108 234-15	9	11-250 084-15	21	12-024 191-15	43, 44	13-070 193-05	18
11-108 285-15	24	11-305 185-15	30	12-024 191-25	21	14-215 238-23	14
11-130 167-15	30, 31	11-330 166-15	13, 20	12-024 211-15	9	14-218 050-01	22
11-130 173-15	11, 22, 28	11-330 169-15	29	12-305 084-15	32	14-602 901-01	21
11-130 176-15	32	11-330 190-15	11	12-305 114-15	11, 26, 32	15-032 002-45	33
11-130 176-25	35	11-330 205-15	38	12-305 144-15	11	15-032 006-45	31
11-130 185-15	11, 32	11-330 220-15	13	12-305 174-15	19, 24	15-711 050-51	14
11-130 191-25	35	11-330 277-15	26	12-305 174-25	39	16-049 040-11	43, 44
11-130 224-15	11, 22	11-330 280-15	10, 11, 12, 16, 17, 23	12-333 230-15	9	16-414 141-05	37
11-130 227-15	18, 20, 31	11-330 952-15	15, 21	12-335 171-15	14	18-372 004-91	33
11-130 254-15	9	11-330 955-15	28, 30, 32	12-335 191-15	33	18-372 008-91	31
11-130 284-15	19	11-330 960-15	17	12-335 210-15	37	18-378 009-91	31
11-130 287-25	39	11-330 962-15	24	12-341 090-15	22	25-308 820-40	31, 33
11-130 293-15	18, 30	11-330 964-15	27	12-360 061-05	22	26-534 300-50	12, 16, 20
11-130 293-25	20	11-330 968-15	14, 16	12-360 063-05	22	26-536 304-09	12, 16, 20
11-130 305-15	33	11-335 902-15	17	12-499 120-45	32	28-011 201-44	45
11-130 341-15	15	11-341 166-15	19	12-499 150-45	32, 38	28-011 202-05	45
11-130 359-15	9	11-341 220-15	19	12-510 171-45	43, 44	28-011 202-43	45
11-130 395-15	9	11-341 280-15	23	12-610 170-45	10	28-011 202-47	45

No. 零件号	Seite Page Página 页号	No. 零件号	Seite Page Página 页号	No. 零件号	Seite Page Página 页号	No. 零件号	Seite Page Página 页号
61-111 600-01	42	91-000 250-15	23, 25	91-009 618-05	20	91-013 790-01	9
61-111 600-35	42	91-000 262-25	22	91-009 624-05	20	91-014 021-12	24
61-111 633-61	42	91-000 277-15	22	91-009 702-02	20	91-014 039-70/895	20
70-252 151-53	32	91-000 338-15	22	91-010 022-05	20	91-014 040-71/895	20
70-377 000-04	32	91-000 366-15	13	91-010 023-05	13	91-014 046-05	28
71-160 001-11	32	91-000 390-05	23, 25	91-010 026-21	13	91-014 614-05	23
71-170 001-31	30	91-000 452-15	28	91-010 115-05	13	91-014 615-05	24
71-210 001-25	30	91-000 509-15	23	91-010 116-05	13	91-014 676-90	23
71-370 001-08	40	91-000 510-15	20	91-010 181-25	13	91-014 696-15	19
71-370 001-31	30	91-000 511-15	22, 28	91-010 183-05	13	91-014 697-15	19
71-370 001-32	32, 35	91-000 524-05	13	91-010 185-05	13	91-014 716-05	17
71-370 001-33	32	91-000 624-15	24	91-010 186-15	13	91-014 747-91	22
71-370 002-91	40	91-000 625-15	22	91-010 196-05	16	91-014 785-05	23
71-370 003-09	32, 40	91-000 638-05	22, 28	91-010 596-05	16, 20	91-014 846-92	27
71-520 006-01	38	91-000 678-15	23, 25	91-010 825-05	14	91-014 849-05	29
71-520 006-02	37	91-000 713-15	23, 25	91-011 712-05	22	91-014 850-05	28
71-520 006-04	37	91-001 283-15	43, 44	91-011 717-12	24	91-014 851-05	28
71-520 006-05	37	91-001 522-25	13	91-011 753-05	15	91-014 851-92	28
71-550 001-12	32	91-001 601-15	18	91-011 771-05	20	91-014 855-05	29
71-590 007-21	38	91-002 134-05	23, 25	91-011 778-05	14	91-014 856-91	29
71-590 007-32	35	91-003 113-05	9	91-012 761-90	17	91-014 858-91	30
71-590 007-77	36	91-004 005-05	13	91-013 040-92	16	91-014 861-11	30
71-590 007-82	39	91-004 006-05	13	91-013 091-05	13	91-014 865-91	28
71-590 007-92	35	91-004 309-05	10	91-013 113-91	18	91-014 870-05	28
71-590 008-27	34	91-006 505-05	13	91-013 114-15	18	91-014 873-05	27
71-590 008-28	36	91-008 618-05	16, 20	91-013 115-05	18	91-014 877-11	30
71-770 000-63	35	91-009 026-05	23	91-013 116-15	18	91-014 878-05	30
91-000 019-15	18	91-009 076-61	23	91-013 121-05	18	91-014 879-05	30
91-000 032-15	19	91-009 328-91	13	91-013 122-05	18	91-014 883-11	30
91-000 073-15	22	91-009 603-75/895	20	91-013 123-92	18	91-014 884-05	30
91-000 086-15	22	91-009 605-05	20	91-013 130-25	20	91-014 885-90	27
91-000 094-25	28	91-009 609-05	20	91-013 191-05	13	91-014 886-12	28
91-000 243-15	18	91-009 617-05	20	91-013 193-91	13	91-014 887-05	28

No. 零件号	Seite Page Página 页号	No. 零件号	Seite Page Página 页号	No. 零件号	Seite Page Página 页号	No. 零件号	Seite Page Página 页号
91-014 889-05	28	91-027 373-72/698	43	91-100 213-05	12	91-140 372-05	10
91-014 890-05	30	91-027 375-15	43	91-100 334-15	24	91-140 377-15	14
91-014 897-01	29	91-027 385-70/698	44	91-100 341-15	27	91-140 378-05	14
91-014 926-91	30	91-029 692-75/792	43	91-100 342-15	27	91-140 379-92	14
91-014 928-91	30	91-031 409-12	43, 44	91-100 366-15	10	91-140 394-05	10
91-014 930-12	30	91-031 888-15	43, 44	91-102 715-11	19	91-140 403-91	20
91-015 756-05	30	91-032 325-15	43, 44	91-105 447-25	13	91-140 450-25	10
91-016 135-05	19	91-032 559-15	43, 44	91-106 205-15	22, 28	91-140 481-01	15
91-016 330-11	19	91-032 771-15	43, 44	91-107 162-15	26	91-140 516-75/770	16
91-016 333-92	32	91-033 308-70/698	43	91-118 196-12	10	91-140 582-15	15
91-016 403-05	11	91-033 309-91	43, 44	91-118 430-25	13	91-141 099-05	11
91-016 411-92	18	91-033 312-12	19	91-118 683-05	21	91-141 100-91	11
91-016 412-92	24	91-033 314-91	43, 44	91-119 421-05	14	91-141 442-15	13
91-016 418-91	18	91-033 315-15	43, 44	91-119 590-05	20	91-141 443-15	13
91-016 425-05	24	91-033 316-15	43, 44	91-129 917-91	45	91-141 612-91	17
91-016 431-91	19	91-033 317-05	43, 44	91-140 101-05	16	91-141 617-75/698	9
91-016 432-12	19	91-040 476-25	22	91-140 102-05	16	91-141 618-75/895	9
91-017 378-15	26	91-050 313-05	18	91-140 120-05	17	91-141 620-72/893	17
91-018 358-75/770	16	91-056 578-91	21	91-140 273-05	11	91-141 621-75/895	9
91-018 460-90	27	91-057 720-15	11	91-140 336-15	15	91-141 624-75/895	9
91-018 487-05	15	91-060 461-91	23	91-140 342-01	11	91-141 625-72/895	9
91-019 929-05	25	91-060 581-91	25	91-140 347-01	10	91-141 626-05	15
91-020 207-05	17	91-063 048-05	12	91-140 349-05	10	91-141 628-75/895	9
91-021 372-15	43	91-066 456-05	30	91-140 351-91	10	91-141 632-15	9
91-021 485-41	15	91-069 335-72/893	43	91-140 352-05	10	91-141 633-15	26
91-025 060-72/893	43, 44	91-090 721-90	32	91-140 353-05	10	91-141 634-91	29
91-025 075-75/698	43, 44	91-091 363-71/893	32	91-140 358-05	10	91-141 635-12	29
91-025 077-15	43, 44	91-091 365-15	32	91-140 359-05	10	91-141 636-15	26
91-025 103-15	43	91-091 448-91	32	91-140 360-05	10	91-141 637-75/893	9
91-025 170-15	43	91-091 449-91	32	91-140 363-12	10	91-141 646-71/770	17
91-025 559-25	22	91-095 850-91	30	91-140 366-05	10	91-141 648-05	17
91-027 370-05	43	91-099 267-91	32	91-140 367-05	10	91-141 650-91	22
91-027 371-12	43	91-099 904-45	30	91-140 368-05	10	91-141 651-01	22

No. 零件号	Seite Page Página 页号	No. 零件号	Seite Page Página 页号	No. 零件号	Seite Page Página 页号	No. 零件号	Seite Page Página 页号
91-141 653-05	22	91-166 559-25	13	91-700 689-15	16, 17, 23		
91-141 664-75/895	31	91-166 670-15	35	91-700 875-15	24		
91-141 665-91	11	91-168 025-05	12	91-700 961-15	20, 27		
91-141 668-15	13	91-168 144-15	23	91-700 962-15	27		
91-141 672-75/893	9	91-168 480-15	17	91-700 996-15	21		
91-141 675-05	20	91-169 132-15	11	91-701 545-25	18		
91-141 679-71/698	20	91-169 523-05	14	91-709 392-91	11		
91-141 687-70/698	9	91-171 049-05	21	95-215 000-04/261	31		
91-141 688-90	35	91-171 808-05	10	95-215 040-15/930	31		
91-141 694-05	14	91-173 664-15	11	95-215 040-16/156	31		
91-141 714-91	16	91-174 480-05	25	95-215 040-16/181	31		
91-141 747-05	11	91-174 879-05	21	95-215 040-16/183	31		
91-141 748-05	11	91-174 955-91	25	95-215 080-09/905	31		
91-141 749-91	11	91-175 171-05	26	95-665 735-91	45		
91-141 750-05	11	91-175 690-05	23, 25	95-774 464-05	21		
91-141 751-15	11	91-176 267-05	10	95-774 466-91	21		
91-141 752-75/895	18	91-176 332-25	13	96-710 194-15	22		
91-141 753-71/895	18	91-187 386-75/893	33	96-711 962-05	14		
91-141 758-91	12	91-187 426-70/893	33	99-136 546-91	33		
91-141 765-92	14	91-229 070-70/895	41	99-137 001-05	9		
91-141 766-91	14	91-229 180-90	40	99-137 151-45	21		
91-141 774-75/698	32	91-262 385-75/893	38	99-137 196-05	38		
91-141 829-92	15	91-264 357-05	21	99-137 227-91	31		
91-141 830-15	13	91-264 358-05	21				
91-141 831-15	15	91-290 576-91	37				
91-141 848-91	14	91-291 458-91	39				
91-141 850-91	10	91-291 899-91	39				
91-141 851-91	10	91-700 082-15	13				
91-141 852-91	10	91-700 364-25	9				
91-141 954-91	23	91-700 412-25	13				
91-141 955-91	25	91-700 510-15	14				
91-165 505-05	29	91-700 592-15	15				
91-166 452-21	21	91-700 680-15	17, 23				

337

UNTERKLASSEN-AUSSTATTUNG

SUBCLASS PARTS

COMPOSICIÓN DE LAS SUBCLASES

子机型-设备

15.01 Nähwerkzeuge[▲] Gauge parts Organos de costura 缝纫工具

PFAFF 337-G

-2/21

Für rechte Kantennäharbeiten.
(Standardform des Teilesatzes.)

For right edge sewing.
(Standard parts set.)

Para costura marginales a la derecha.
(Juego de piezas estándar.)

用于右侧的棱边缝纫工作。
(配套组件的标准形式。)

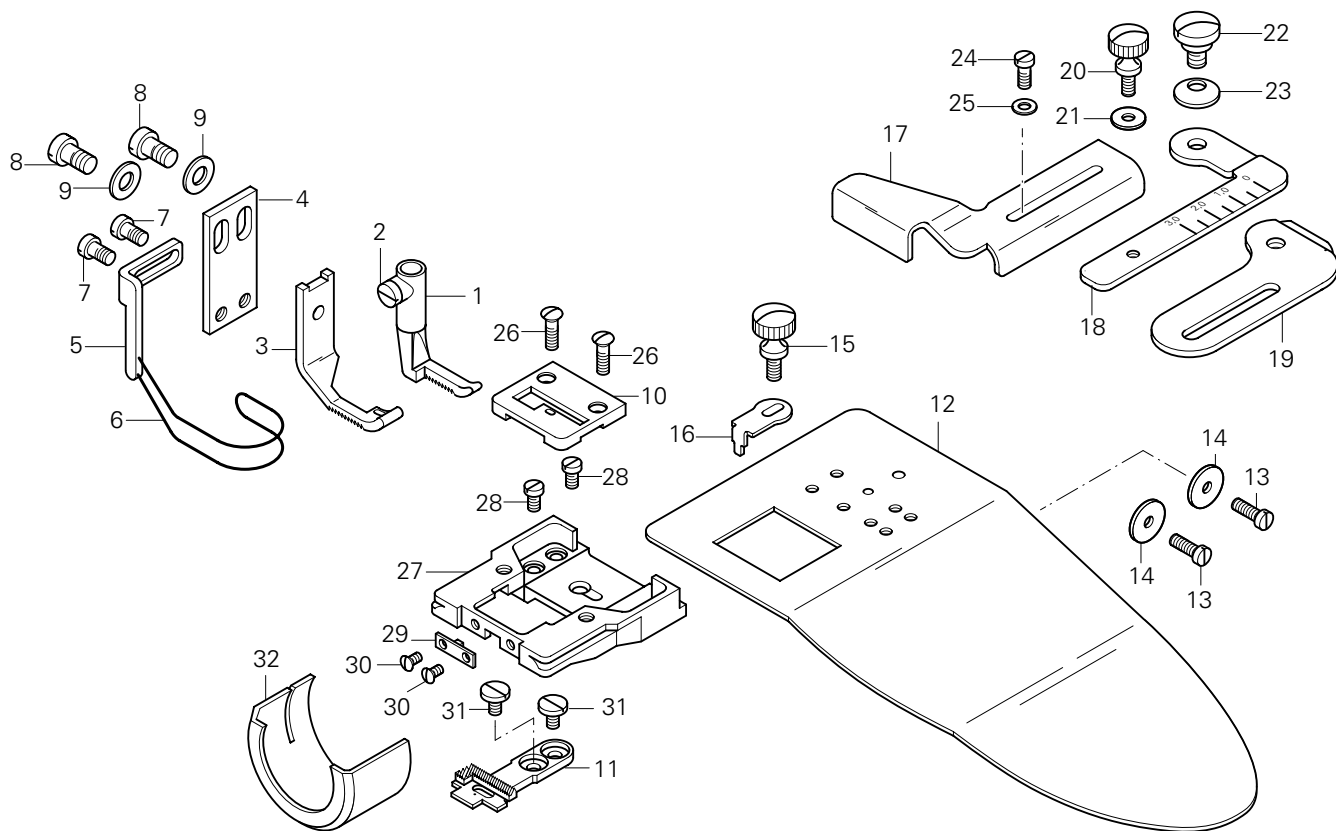

Pos.-Nr. Item No. 序号	Ausführung Model Typo 款式	Stichlänge Stitch length Largo de puntada 针距	Teile-Nr. Part No. 零件号
1 - 23	BN36 [◆]	3,0	91-201 159-93/001
1 - 2			91-049 275-92
2			91-000 085-15
3			91-049 732-05
4 - 7			91-057 721-91
4			91-057 720-15
5 - 6			91-057 697-91
5			91-154 702-15
6			91-055 205-05 3
7			11-108 171-15
8			11-108 222-15
9			12-305 144-15
10			91-058 987-05
11			91-059 574-05
12			91-016 424-21
13			91-000 073-15
14			12-341 090-15
15			91-000 262-15

Pos.-Nr. Item No. 序号	Ausführung Model Typo 款式	Stichlänge Stitch length Largo de puntada 针距	Teile-Nr. Part No. 零件号
16			91-025 559-25
17 - 23			91-046 596-91
17			91-046 594-25
18			91-046 595-25
19			91-046 597-25
20			91-000 113-25
21			12-341 090-15
22			91-001 089-25
23			91-006 030-25
24			11-108 168-15
25			12-305 111-15
26			91-000 277-25
27			91-014 636-25
28			91-000 086-15
29			91-014 637-24/001
30			91-000 625-25
31			91-000 338-15
32			91-014 961-25

Nähwerkzeuge▲

Gauge parts

Organos de costura

缝纫工具

PFAFF 337

PFAFF 337-G

15.01

-6/01

Für allgemeine Näharbeiten.
(Standardform des Teilesatzes.)

For ordinary sewing operations.
(Standard part set.)

Para trabajos de costura en general.
(Juego de piezas estándar.)

适用于一般性缝纫工作。
(套件的标准型式。)

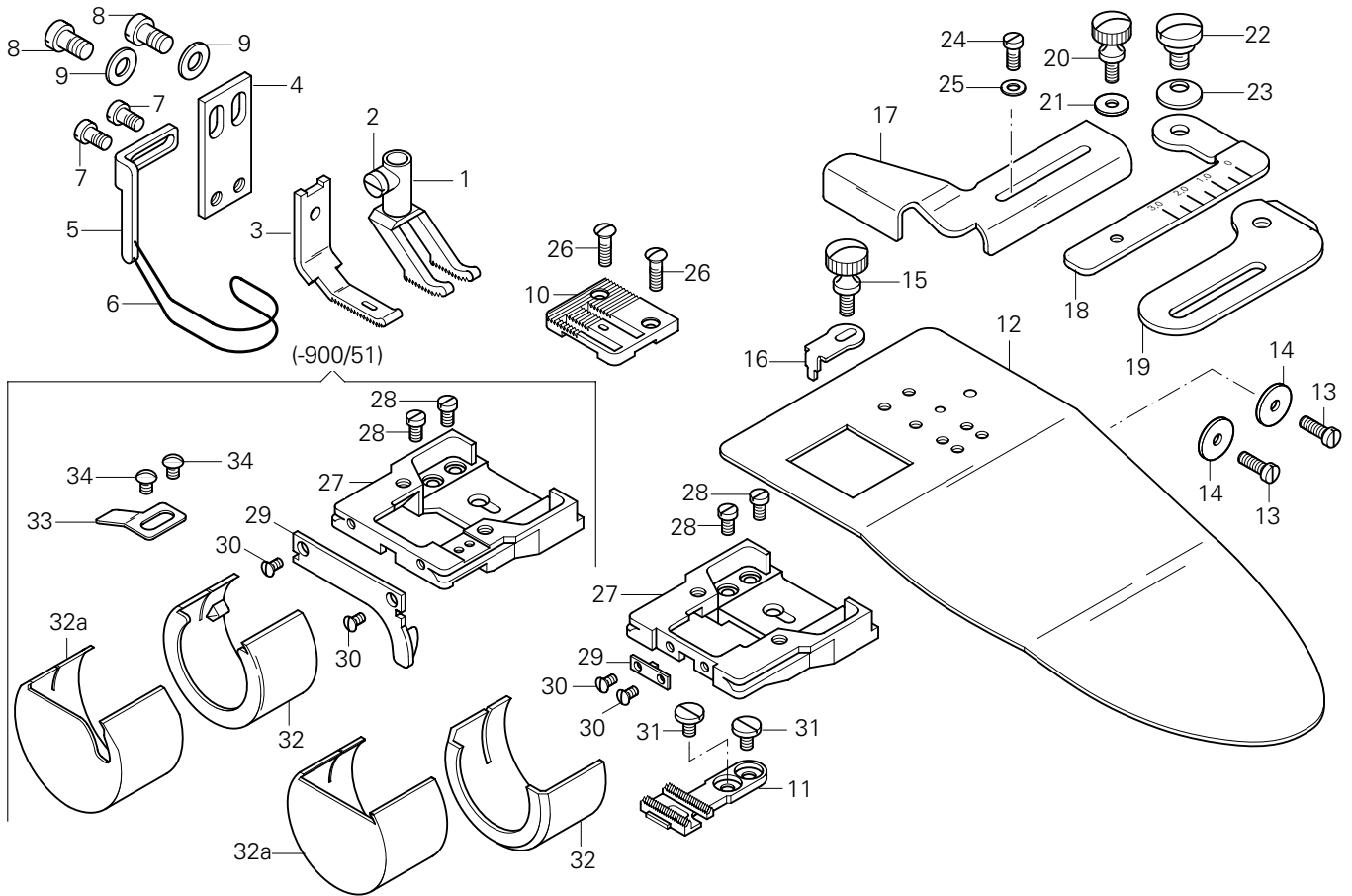

Pos.-Nr. Item No. 序号	Ausführung Model Typo 款式	Stichlänge Stitch length Largo de puntada 针距	Teile-Nr. Part No. 零件号	Pos.-Nr. Item No. 序号	Ausführung Model Typo 款式	Stichlänge Stitch length Largo de puntada 针距	Teile-Nr. Part No. 零件号
1 - 23	BN36◆	3,0	91-201 157-93/001	19			91-046 597-25
1 - 2			91-049 215-92	20			91-000 113-25
2			91-000 085-15	21			12-341 090-15
3			91-049 733-05	22			91-001 089-25
4 - 7			91-057 721-91	23			91-006 030-25
4			91-057 720-15	24			11-108 168-15
5 - 6			91-057 697-91	25			12-305 111-15
5			91-154 702-15	26			91-000 277-25
6			91-055 205-05 3	27			91-014 636-25
7			11-108 171-15				91-014 047-25 (-900/51)
8			11-108 222-15	28			91-000 086-15
9			12-305 144-15	29			91-014 637-24/001
10			91-058 729-05				91-014 893-24/002(-900/51)
11			91-047 947-05	30			91-000 625-25
12			91-016 424-21				91-000 452-25 (-900/51)
13			91-000 073-15	31			91-000 338-15
14			12-341 090-15	32			91-014 961-25 90/80
15			91-000 262-15				91-014 959-25 90/80 (-900/51)
16			91-025 559-25	32a			91-014 638-25 90/79
17 - 23			91-046 596-91				91-014 892-25 90/79 (-900/51)
17			91-046 594-25	33			91-014 046-05 (-900/51)
18			91-046 595-25	34			91-000 094-15 (-900/51)

3 / ◆ siehe Kapitel 2 Erläuterung der Schlüsselzeichen
see chapter 2 Explanation of key markings
véase el Cap. 2 Explicaciones de los signos clave
见第2章标记说明

▲ Weitere Unterklassen und Ausführungen auf Anfrage
Further Subclasses and versions on enquiry
Otras subclases y tipos, sobre demanda
更多的子机型和款式请咨询



Europäische Union
Wachstum durch Innovation – EFRE

PFAFF Industriesysteme und Maschinen AG

Hans-Geiger-Str. 12 - IG Nord
D-67661 Kaiserslautern

Telefon: +49 - 631 200-0
Telefax: +49 - 631 17202
E-mail: info@pfaff-industrial.com

Hotlines:

Technischer Service / Technical service: +49 - 175 2243-101

Nähtechnik-Fachberatung / Application consultancy: +49 - 175 2243-102

Ersatzteile-Hotline / Spare-parts hotline: +49 - 175 2243-103