

PFAFF

3307 - 1/.., - 3/.., - 4/.., - 5/.., - 9/..

Teileliste

Parts list

Liste de pièces

Lista de piezas

Diese Teileliste hat für Maschinen ab nachfolgender
Seriennummer Gültigkeit:

This parts list applies to machines from the following
serial numbers onwards:

Cette liste de pièces est valable pour les machines au
numéros de série à partir de:

Esta lista de piezas tiene validez para máquinas a partir del
número de serie siguiente:

2716260 →

Alle Informationen und Abbildungen waren zum Zeitpunkt der Druckgebung auf dem neusten Stand.

Technische Änderungen vorbehalten!

Der Nachdruck, die Vervielfältigung sowie die Übersetzung - auch auszugsweise - aus PFAFF-Teilelisten ist nur mit unserer vorherigen Zustimmung und mit der Quellenangabe gestattet.

At the time of printing, all information and illustrations contained in this document were up to date.

Subject to alteration!

The reprinting, copying or translation of PFAFF Parts lists whether in whole or in part, is only permitted with our previous permission and with written reference to the source.

Au moment de la remise à l'imprimeur, toutes les informations et figures se rapportant à cette machine correspondaient à l'état actuel des connaissances.

Sous réserve de modifications techniques!

Aucune reproduction, polycopie ou traduction - même par extraits - des listes de pièces PFAFF ne peut être effectuée, à condition d'en indiquer l'origine, sans notre autorisation expresse.

Todas las informaciones e ilustraciones de este manual estaban al día en el momento de entregarse para su impresión.

¡ Salvo modificaciones técnicas!

La reimpresión, reproducción y traducción - aunque sólo sea parcial - de las listas de piezas PFAFF sólo está permitida con nuestro permiso previo e indicando la fuente.

PFAFF Industrie Maschinen AG

Postfach 3020
D-67653 Kaiserslautern
Königstr. 154
D-67655 Kaiserslautern

Redaktion/Illustration
Verlag Technische Dokumentation
Postfach 1106
D-77901 Lahr

| | Seite Page Page Página |
|--|--|
| 0 Wichtiger Hinweis | 0 - 1 |
| Important note | |
| Avis important | |
| Observación importante | |
| | |
| 1 Vorwort | 1 - 1 |
| Foreword | |
| Avant-propos | |
| Notas preliminares | |
| | |
| 2 Erläuterungen der Schlüsselzeichen | 2 - 1 |
| Explanation of key markings | |
| Explication des symboles | |
| Explicaciones de los signos clave | |
| | |
| 3 Basismaschine | |
| Basic machine | |
| Machine de base | |
| Máquina básicas | |
| | |
| 3.01 Gehäuseteile | 3 - 1 |
| Housing sections | |
| Parties du corps | |
| Piezas del cárter | |
| | |
| 3.02 Kopfteile | 3 - 2 |
| Needle head parts | |
| Pièces de tête | |
| Piezas de la cabeza | |
| | |
| 3.03 Armteile | 3 - 4 |
| Arm parts | |
| Pièces de bras | |
| Piezas del brazo | |
| | |
| 3.04 Freiarmteile | 3 - 11 |
| Cylinder bed parts | |
| Pièces du bras inférieur | |
| Piezas del brazo al aire | |
| | |
| 4 Wartungseinheit (-925/03) | 4 - 1 |
| Air filter / lubricator (-925/03) | |
| Conditionneur d'air comprimé (-925/03) | |
| Grupo acondicionador del aire comprimido (-925/03) | |

| | Seite Page Page Página |
|--|---------------------------------|
| 5 Pneumatische Ausrüstung | 5 - 1 |
| Pneumatic equipment | |
| Équipement pneumatique | |
| Equipo neumático | |
| | |
| 6 Elektrische Ausrüstung | |
| Electrical equipment | |
| Équipement électrique | |
| Equipo eléctrico | |
| | |
| 6.01 Kabelbaum zum Oberteil | 6 - 1 |
| Cable tree to sewing head | |
| Faisceau de câbles vers la tête de machine | |
| Mazo de cables para el cabezal | |
| | |
| 6.02 Fadenkraft-Senor | 6 - 2 |
| Thread strength-sensor | |
| Détecteur de la force du fil | |
| Sensor-fuerza de hilo | |
| | |
| 6.03 Tastschalter | 6 - 3 |
| Push-button switch | |
| Interrupteur à bouton-poussoir | |
| Interruptur pulsador | |
| | |
| 6.04 Einbaumotor | 6 - 4 |
| Built-in motor | |
| Moteur incorporé | |
| Motor incorporado | |
| | |
| 6.05 Bedienfeld | 6 - 5 |
| Control panel | |
| Panneau de commande | |
| Panel de mandos | |
| | |
| 6.06 Motor-Hauptschalter | 6 - 5 |
| Main switch | |
| Interrupteur général | |
| Interruptor principal | |
| | |
| 6.07 Sollwertgeber | 6 - 6 |
| Set-point generator | |
| Codeur | |
| Emisor del valor teórico | |

| | Seite Page Page Página |
|---|--|
| 6.08 Steuerkasten | 6 - 7 |
| Control box | |
| Boîte de contrôle | |
| Caja de mandos | |
| 6.09 Steuergerät | 6 - 8 |
| Control device | |
| Boîte de commande | |
| Caja de mandos | |
| 7 Garnrollenständer | 7 - 1 |
| Reel stands | |
| Porte-bobines | |
| Portacarretes | |
| 8 Einstellehren | 8 - 1 |
| Adjustment gauges | |
| Calibres | |
| Calibres de ajuste | |
| 9 Schmiermittel-Übersicht | 9 - 1 |
| Overview of lubricants | |
| Tableau de lubrifiants | |
| Tabla de lubricantes | |
| 10 Abweichende Teile der PFAFF 3307-1/11 | 10 - 1 |
| Different parts for PFAFF 3307-1/11 | |
| Pièces divergentes de la PFAFF 3307-1/11 | |
| Piezas de la PFAFF 3307-1/11 que son diferentes | |
| 11 Abweichende Teile der PFAFF 3307-3/01 | 11 - 1 |
| Different parts for PFAFF 3307-3/01 | |
| Pièces divergentes de la PFAFF 3307-3/01 | |
| Piezas de la PFAFF 3307-3/01 que son diferentes | |
| 12 Abweichende Teile der PFAFF 3307-5/01 | 12 - 1 |
| Different parts for PFAFF 3307-5/01 | |
| Pièces divergentes de la PFAFF 3307-5/01 | |
| Piezas de la PFAFF 3307-5/01 que son diferentes | |
| 13 Abweichende Teile der PFAFF 3307-9/01 | 13 - 1 |
| Different parts for PFAFF 3307-9/01 | |
| Pièces divergentes de la PFAFF 3307-9/01 | |
| Piezas de la PFAFF 3307-9/01 que son diferentes | |

| | Seite Page Page Página |
|--|--|
| 14 Sonderausführung | 14 - 1 |
| Special version | |
| Version spéciale | |
| Tipo especial | |
| | |
| 15 Index (Teilenummern/Seitenzahlen) | 15 - 1 |
| Index (part numbers / page numbers) | |
| Index (numéros de pièces, de pages) | |
| Index (números de pieza / números de página) | |
| | |
| 16 Unterklassen-Ausstattung | |
| Subclass parts | |
| Composition des sous-classes | |
| Composición de las subclases | |
| | |
| 16.01 Nähwerkzeuge | 16 - 2 |
| Gauge parts | |
| Organes de couture | |
| Organos de costura | |

Achtung!



Wir machen ausdrücklich darauf aufmerksam, daß Ersatz- und Zubehörteile, die nicht von uns geliefert werden, auch nicht von uns geprüft und freigegeben sind. Der Einbau und / oder die Verwendung solcher Produkte kann daher u. Umständen konstruktiv vorgegebene Eigenschaften Ihrer Maschine negativ verändern. Für Schäden, die durch die Verwendung von Nicht-Originalteilen entstehen, übernehmen wir keine Haftung!

Caution!



We warn you expressively that spare parts and accessories that are not supplied by us are not tested and released by us. Fitting or using these products may therefore have negative influences on features that depend on the machine design. We are not liable for any damage caused by the use of non-Pfaff parts!

Attention!



Nous attirons expressément votre attention sur le fait que les pièces de rechange et accessoires qui n'ont pas été livrés par nous n'ont pas non plus été contrôlés et agréés par nous. C'est pourquoi le montage et/ou l'utilisation de telles pièces peut éventuellement entraîner l'altération des caractéristiques de construction de votre machine. Par conséquent, nous n'assumons aucune responsabilité pour les dommages causés par l'emploi de pièces qui ne sont pas d'origine!

¡Atención!



Se hace observar que en el caso de piezas de recambio y accesorios que no hayan sido suministrados por nosotros, quiere decir que non han sido sometidas por nuestra parte a un control y que no se les ha dado el visto bueno. Por esta razón, el montaje y/o empleo de tales productos puede repercutir negativamente en las características previstas en su máquina. ¡Para los daños que eventualmente pudiesen presentarse al utilizar piezas no originales, no asumimos ninguna garantía!

- Die Seriennummer der Maschine, für die diese Teileliste Gültigkeit hat, ist auf der Titelseite aufgeführt.
 - Alle Teile sind so abgebildet, wie sie in der Maschine funktionsmäßig zusammengehören.
 - Gestrichelt dargestellte Teile zeigen angrenzende Teile aus anderen Funktionsgruppen.
 - Im oberen Teil der Bildseiten befindet sich eine Gesamtansicht der Maschine .
 - Der Einbauort der dargestellten Teile wird durch eine gerasterte Fläche gekennzeichnet.
 - Einrahmungen auf den Bildseiten zeigen, aus welchen Einzelteilen sich die Gruppenteile zusammensetzen.
 - Die auf den Bildseiten verwendeten Schlüsselzeichen (; 2 ; 3 usw.) sind im Kapitel "Erläuterungen der Schlüsselzeichen" aufgelistet.
-
- The serial number of the machine to which this parts list applies is indicated on the cover page.
 - All parts are illustrated in function groups with the parts which they function together with in the machine.
 - Parts illustrated with broken lines are parts from other function groups which border on the illustrated function group.
 - The above section of the page of illustrations contains a total view of the machine. The place for the installation of the parts pictured here is marked by the grid.
 - The framed-in sections on the illustration pages show the individual parts comprising a group.
 - The key markings used on the illustrated pages (; 2 ; 3 etc.) are listed in the chapter "Explanation of key markings".
-
- Le numéro de série de la machine pour laquelle cette liste de pièces est valable est indiqué sur la première page.
 - Toutes les pièces sont représentées en fonction de leur groupement fonctionnel dans la machine.
 - Les pièces hâchurées indiquent les pièces limitrophes de groupes de fonctions différents.
 - La partie supérieure des pages de figures comprend une présentation globale de la machine. L'emplacement des pièces représentées est signalé par quadrillages.
 - Les parties encadrées sur les pages à illustrations représentent les pièces individuelles formant groupe.
 - Vous trouverez au chapitre "Explication des symboles" une liste des symboles utilisés sur les pages de figures (; 2 ; 3 etc.)
-
- El número de serie de la máquina para la cual tiene validez esta lista de piezas va indicado en la página de título.
 - Odas las piezas están ilustradas tal como aparecen en la máquina para su funcionamiento.
 - Las piezas representadas con rayitas muestran piezas colindantes de otros grupos de funciones.
 - En la parte superior de las páginas ilustradas se puede ver una vista en conjunto de la máquina.
 - El lugar de montaje de la pieza representada va caracterizada mediante una superficie reticulada.
 - Los recuadros en las páginas ilustradas indican las piezas individuales de que se componen los grupos.
 - Los signos clave (; 2 ; 3 etc.) empleados en las páginas con ilustraciones van listados en el capítulo "Explicaciones de los signos clave".

- Unterklassenabhängig, Teilenummer siehe Unterklassen-Ausstattung.**
Subclass-dependent, for part number see subclass parts listing.
Fonction de la sous-classe; pour le numéro de la pièce, voir "Équipement de sous-classes".
Dependientes de la subclase, para el número de pieza véase "Dotación de subclases".
- 3** **Geklebt**
Part cemented
Pièce collée
Pieza pegada
- 3/1** **Gesichert mit Loctite.**
Secured with Loctite.
Bloqué par Loctite.
Asegurado con Loctite.
- 6** **Nadeldicke und Spitzenform bei Bestellung angeben.**
Needle size and style of point to be stated on order.
Préciser la grosseur de l'aiguille et la forme de la pointe à la commande.
Grosor de aguja y forma de la punta, indíquese en los pedidos.
- 27/1** **Eingeklammerte Zahl = Außendurchmesser in mm.**
Number in brackets = outside diameter in mm
Chiffre entre parenthèses = diamètre extérieur en mm.
Cifra entre paréntesis = diámetro exterior en mm.
- 27/5** **Eingeklammerte Zahl = Länge in mm.**
Number in brackets = length in mm.
Chiffre entre parenthèses = longueur en mm
Cifra entre paréntesis = largura en mm.
- 27/21** **Eingeklammerte Zahl = Nähfeldgröße in mm.**
Number in brackets = size of sewing area in mm.
Chiffre entre parenthèses = dimensions du champ de couture en mm.
Cifra entre paréntesis = tamaño del campo de costura en mm.
- 40/23** **Tränken mit 28-011 201-45; Bestellnummer siehe Seite 9 - 1.**
Grease with 28-011 201-45; for part number see page 9 - 1.
Graisser avec de la graisse 28-011 201-45; n° de commande, voir page 9 - 1.
Engrase con grasa 28-011 201-45; para el número de pedido véase la página 9 - 1.
- 40/25** **Füllen mit 28-011 201-45; Bestellnummer siehe Seite 9 - 1.**
Top up with 28-011 201-45; for part number see page 9 - 1.
Remplir de 28-011 201-45; n° de commande, voir page 9 - 1.
Rellene con 28-011 201-45; para el número de pedido véase la página 9 - 1.
- 40/28** **Fetten mit 28-011 202-69; Bestellnummer siehe Seite 9 - 1.**
Grease with 28-011 202-69; for part number see page 9 - 1.
Graisser avec de la graisse 28-011 202-69; n° de commande, voir page 9 - 1.
Engrase con grasa 28-011 202-69; para el número de pedido véase la página 9 - 1.
- 40/29** **Fetten mit 28-011 202-10; Bestellnummer siehe Seite 9 - 1.**
Grease with 28-011 202-10; for part number see page 9 - 1.
Graisser avec de la graisse 28-011 202-10; n° de commande, voir page 9 - 1.
Engrase con grasa 28-011 202-10; para el número de pedido véase la página 9 - 1.
- 81/3** **Stückzahl je nach Bedarf.**
Quantity as required.
Nombre en fonction du besoin.
Cantidad según sea necesario

90/1

Für Wechselstrom

For single-phase A.C.

Pour du courant alternatif

Para corriente alterna monofásica

95/8

X-Werte bei Bestellung angeben.

Please state x-values on order.

Indiquer les valeurs "x" à la commande.

Indíquese en los pedidos los valores "x".

96

Länge angeben.

State length.

Préciser longueur.

Indíquese la largura.

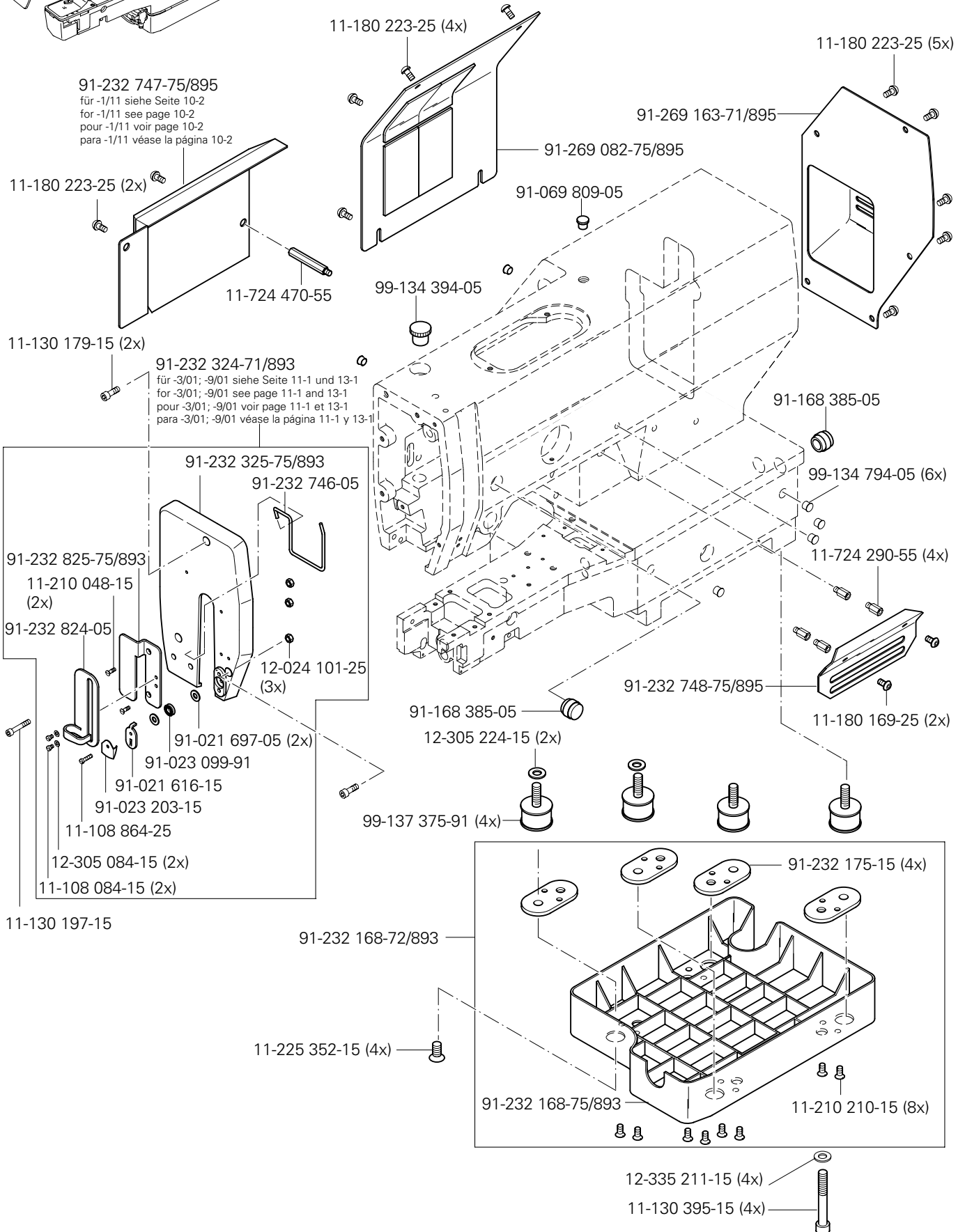
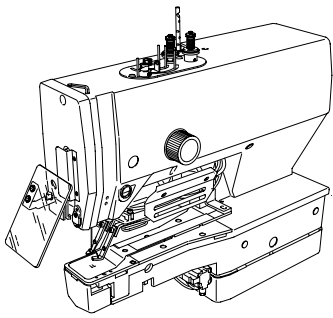

3.02

Kopfteile Needle head parts Pièces de tête Piezas de la cabeza PFAFF 3307

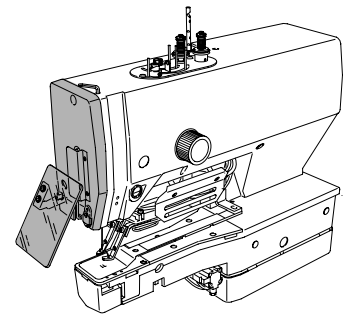

91-233 024-91 (PFAFF 3307 -1/01; -1/02; -1/03; -4/..)

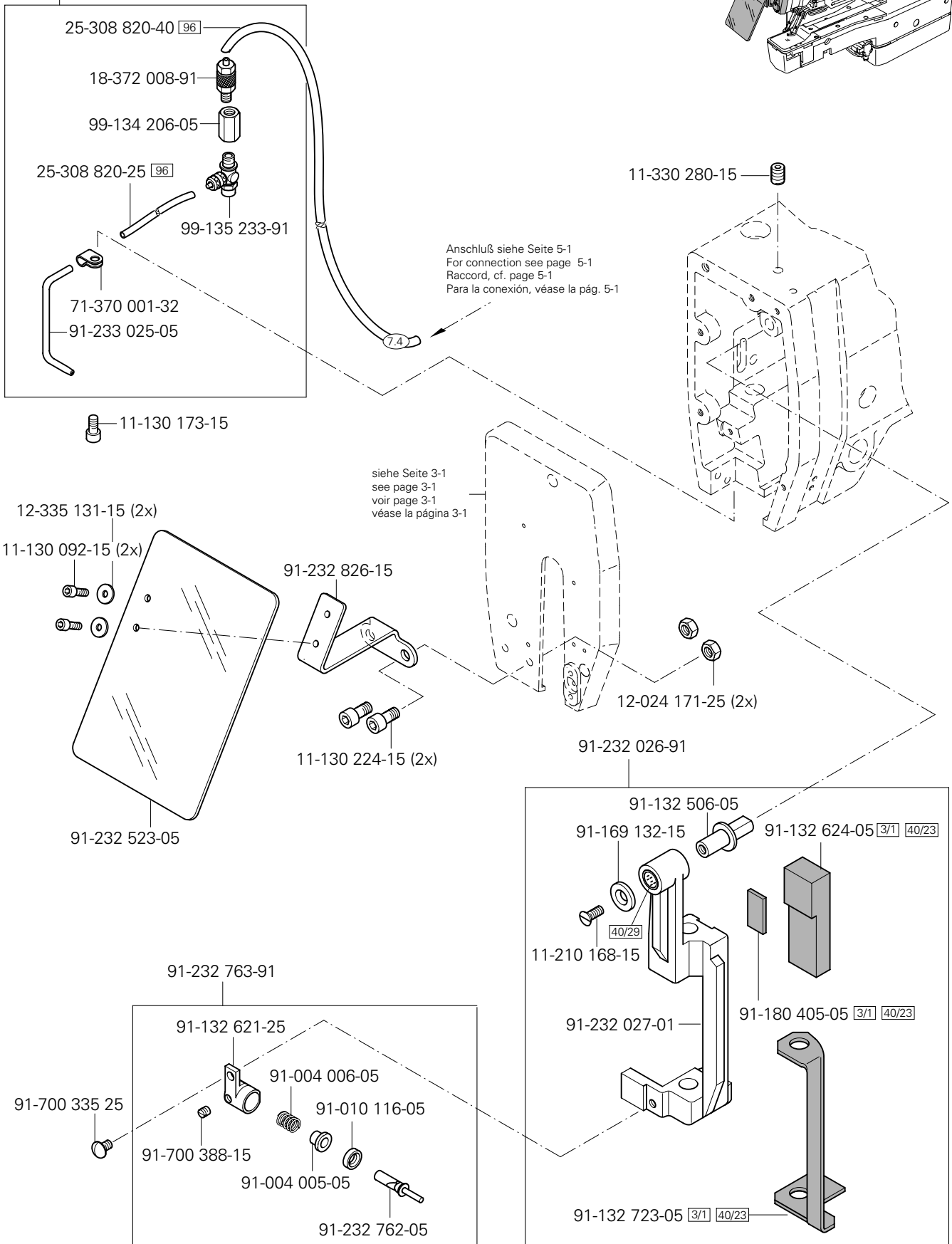

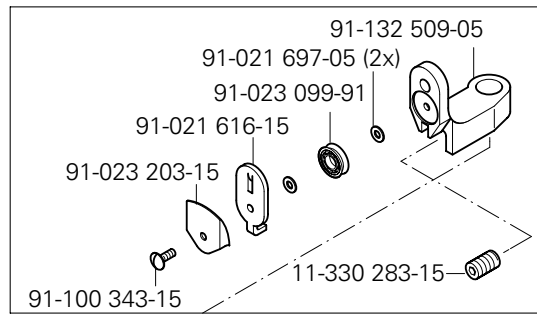
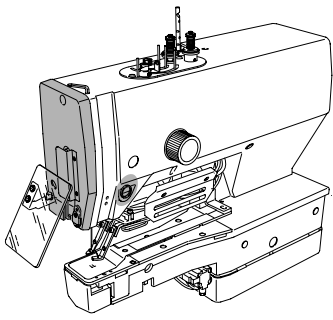

91-132 508-91
 für -3/01; -9/01 siehe Seite 11-1 und 13-1
 for -3/01; -9/01 see page 11-1 and 13-1
 pour -3/01; -9/01 voir page 11-1 et 13-1
 para -3/01; 9/01 véase la página 11-1 y 13-1

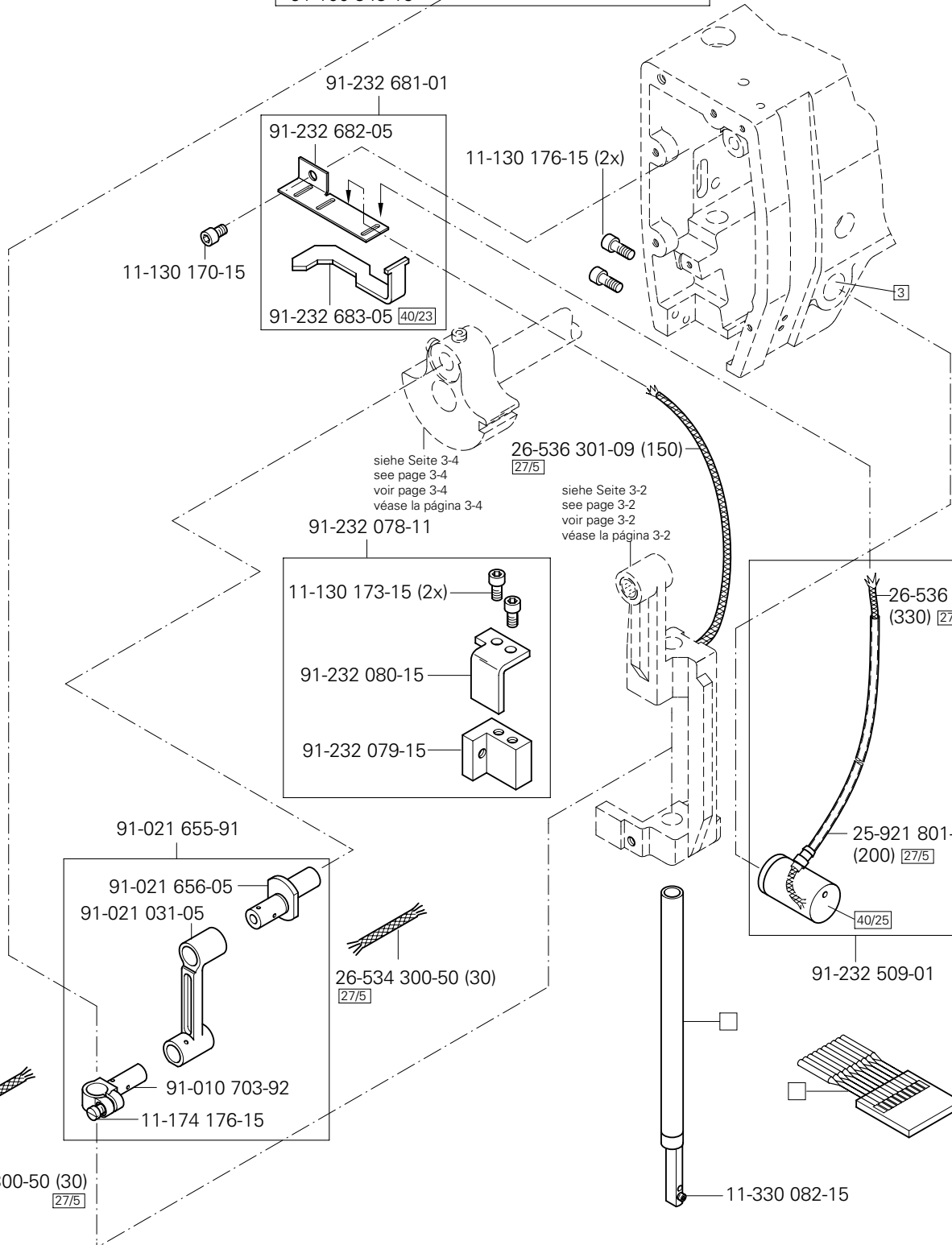

91-232 681-01

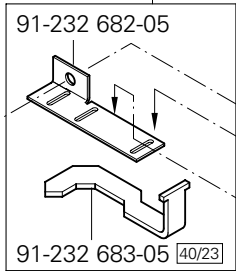

11-130 176-15 (2x)

11-130 170-15

siehe Seite 3-4
 see page 3-4
 voir page 3-4
 véase la página 3-4

26-536 301-09 (150) [27/5]

siehe Seite 3-2
 see page 3-2
 voir page 3-2
 véase la página 3-2

91-232 078-11

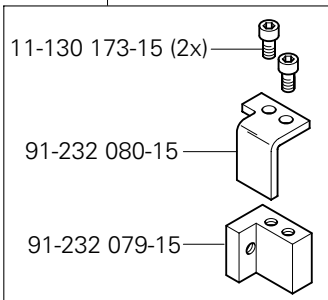

3

26-536 301-09 (330) [27/5]

25-921 801-30 (200) [27/5]

91-232 509-01

91-021 655-91

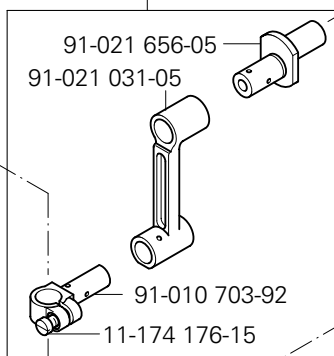

26-534 300-50 (30) [27/5]

26-534 300-50 (30) [27/5]

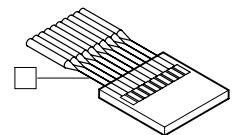
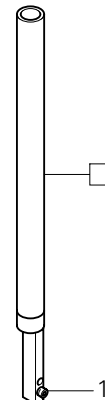

11-330 082-15

3.03

Armteile
 Arm parts
 Pièces de bras
 Piezas del brazo PFAFF 3307

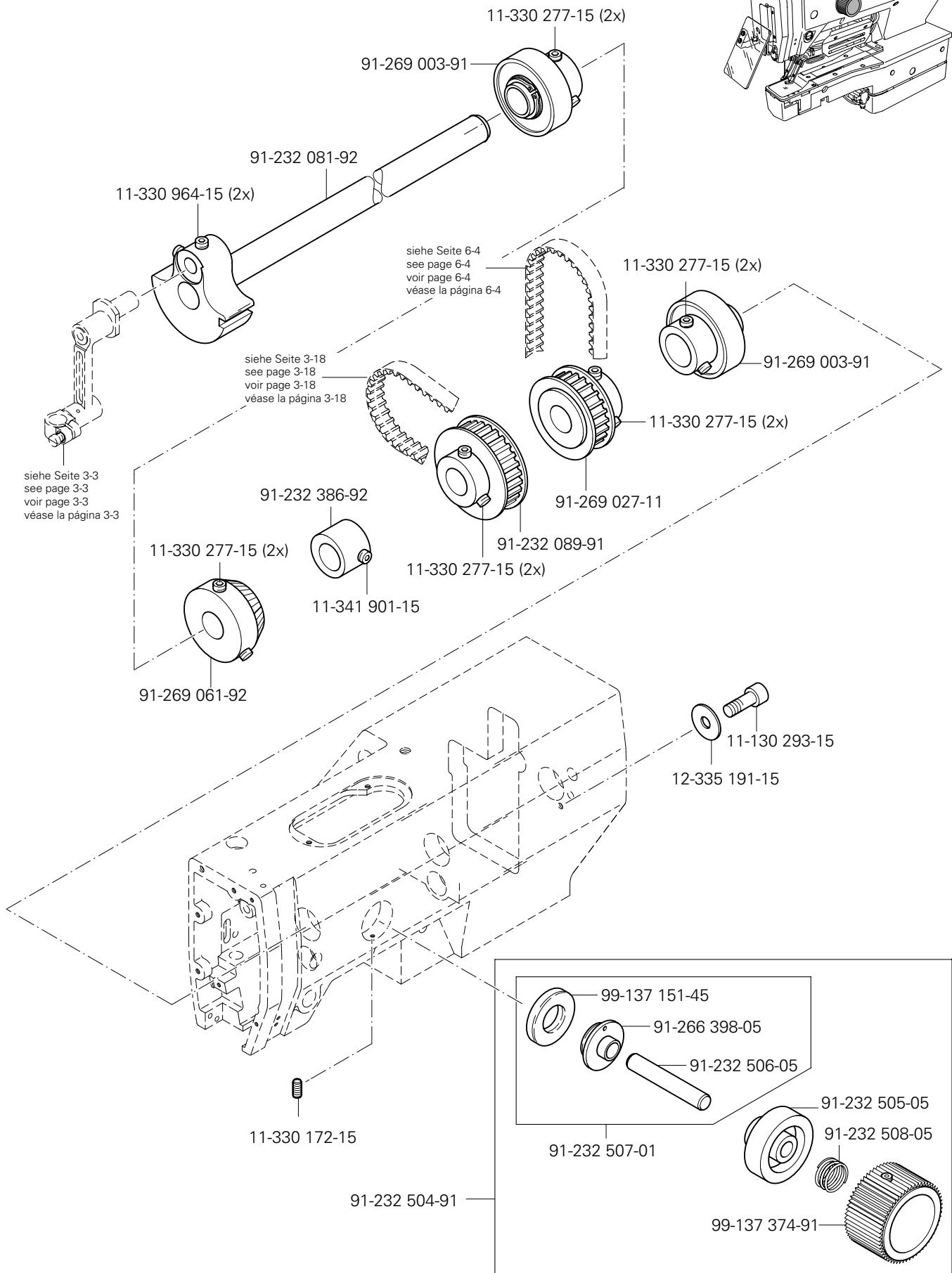
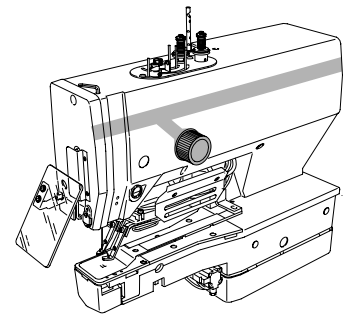

Armteile
 Arm parts
 Pièces de bras
 Piezas del brazo PFAFF 3307

3.03

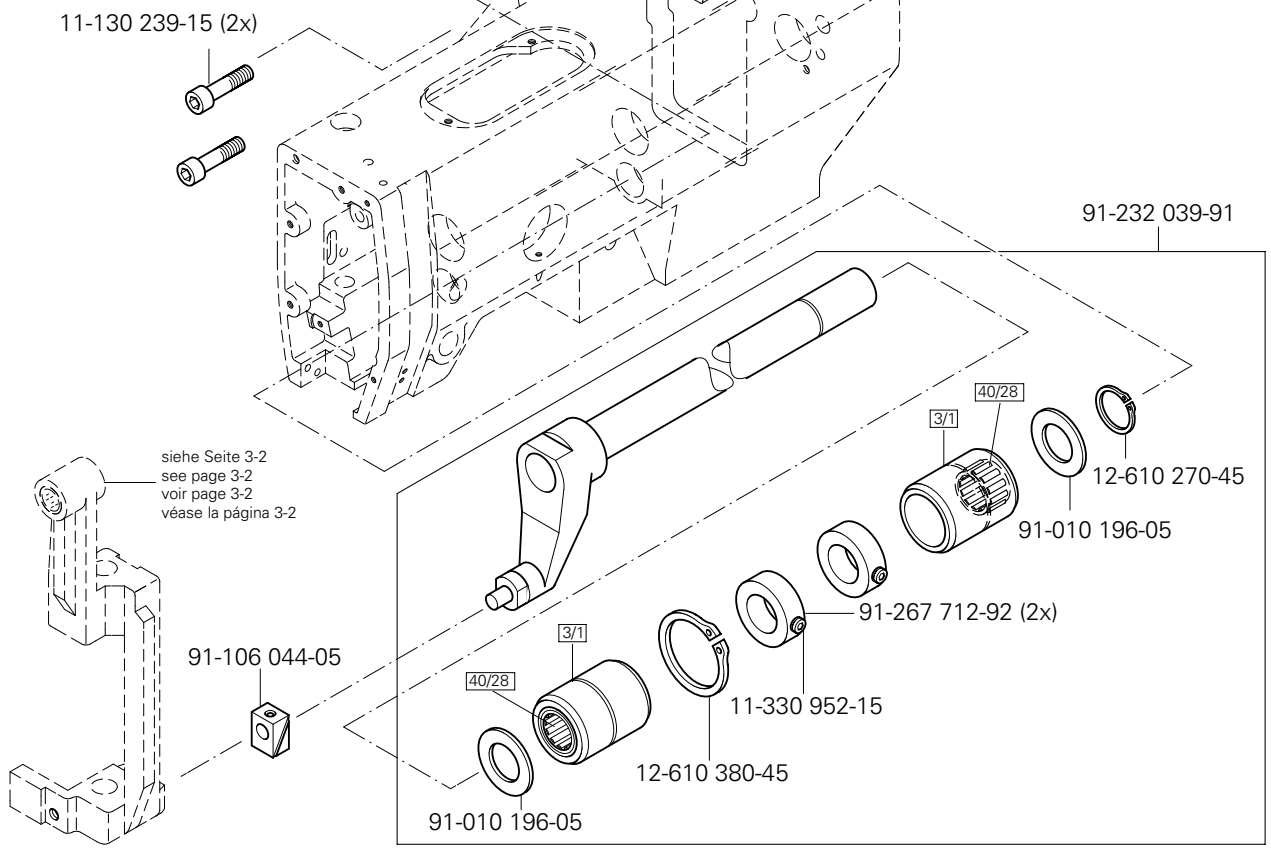
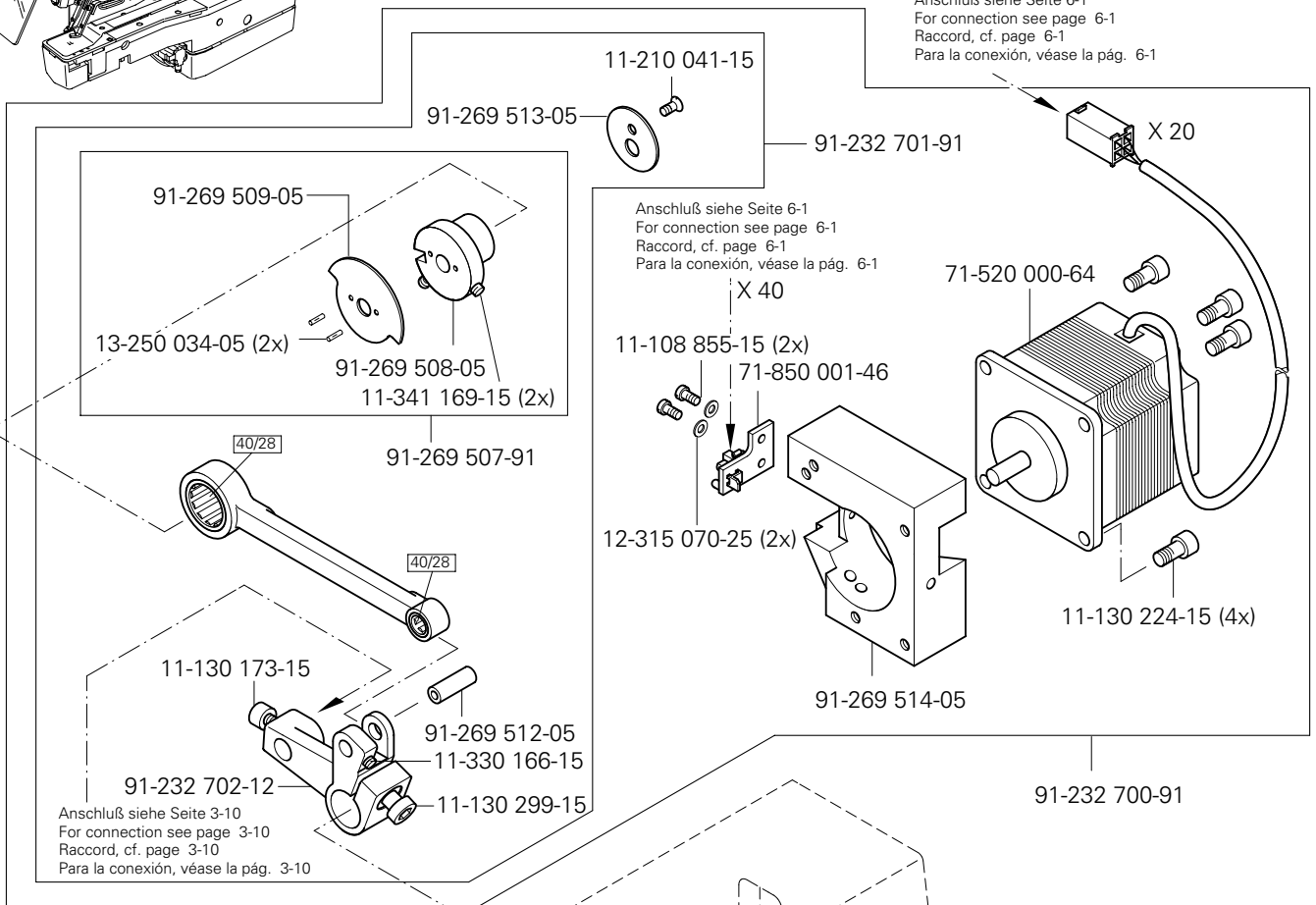
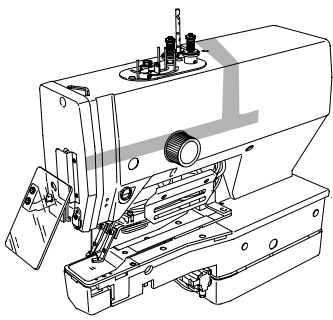

3.03

Armteile Arm parts Pièces de bras Piezas del brazo PFAFF 3307

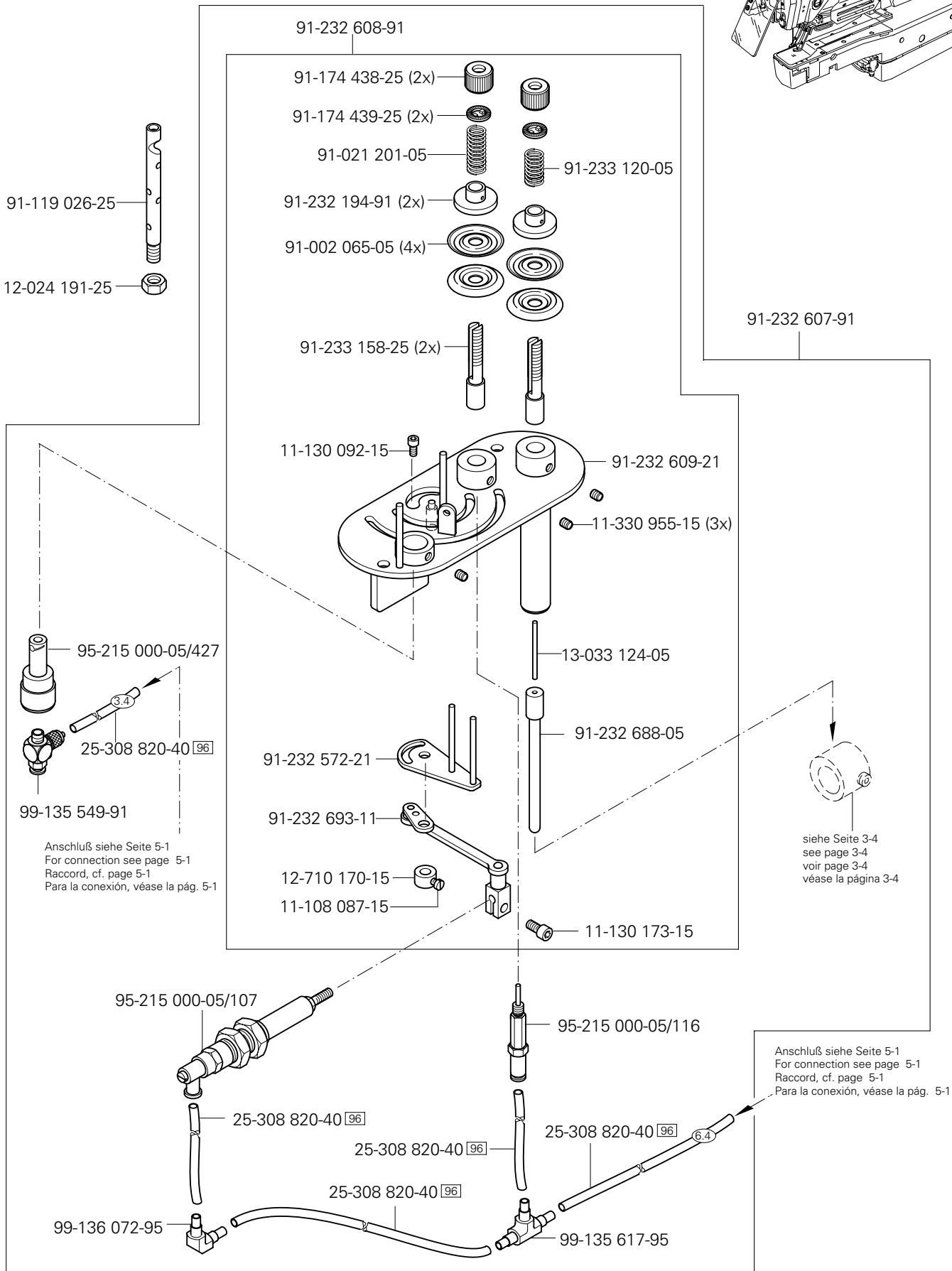
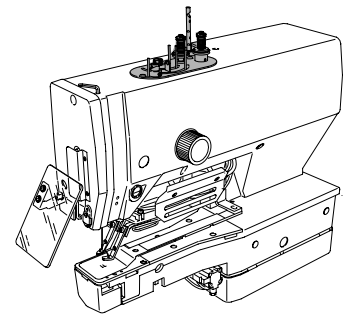

Armteile
 Arm parts
 Pièces de bras
 Piezas del brazo PFAFF 3307

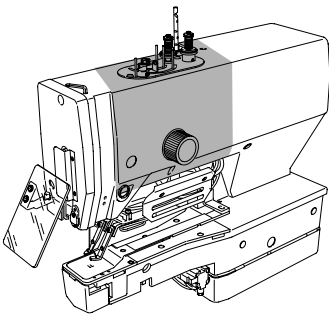

91-232 750-91 für -5/01; -9/01 siehe Seite 12-2 und 13-2
 for -5/01; -9/01 see page 12-2 and 13-2
 pour -5/01; -9/01 voir page 12-2 et 13-2
 para -5/01; -9/01 véase la página 12-2 y 13-2

Anschluß siehe Seite 6-1
 For connection see page 6-1
 Raccord, cf. page 6-1
 Para la conexión, véase la pág. 6-1

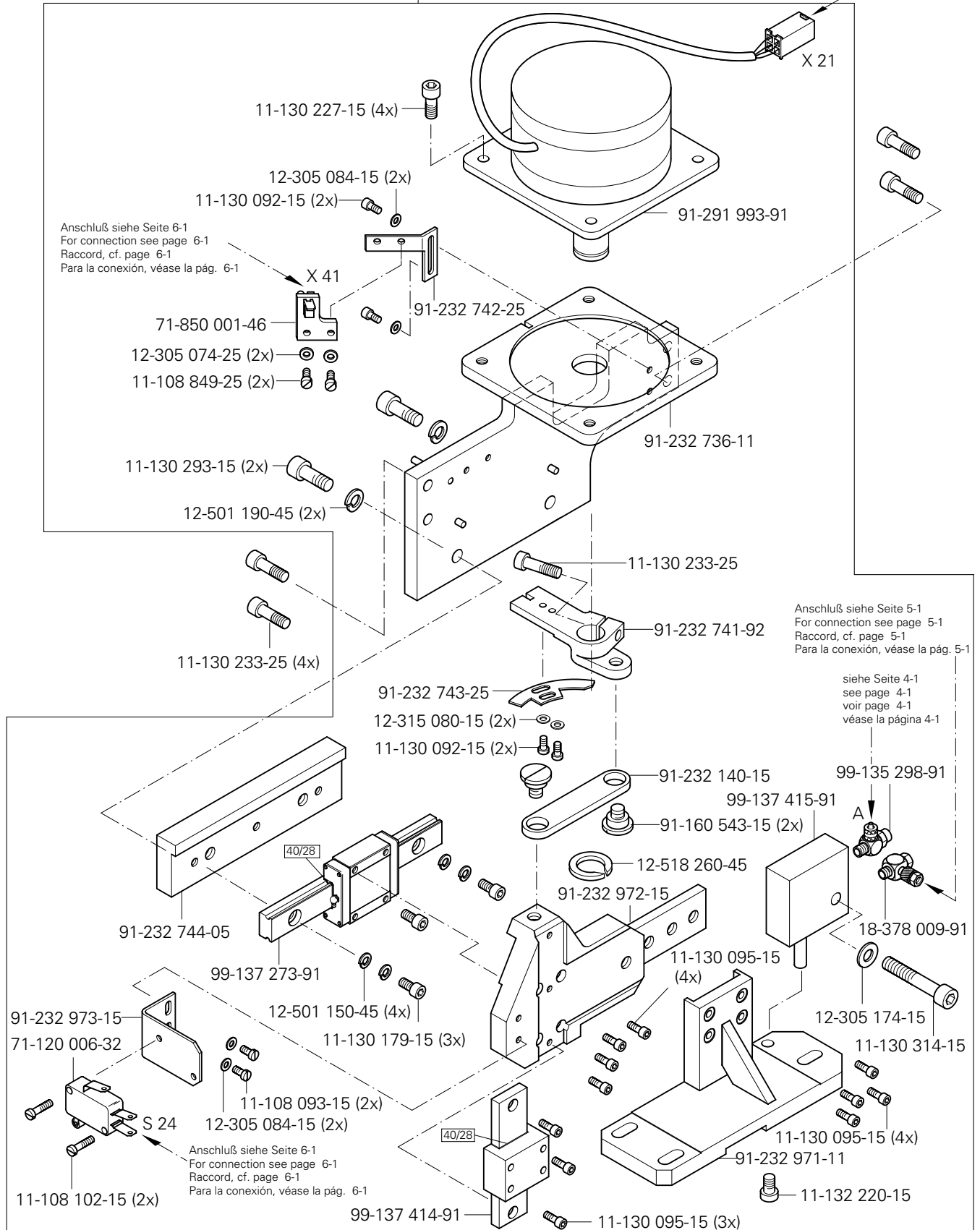

3.03

Armteile
Arm parts
Pièces de bras
Piezas del brazo PFAFF 3307

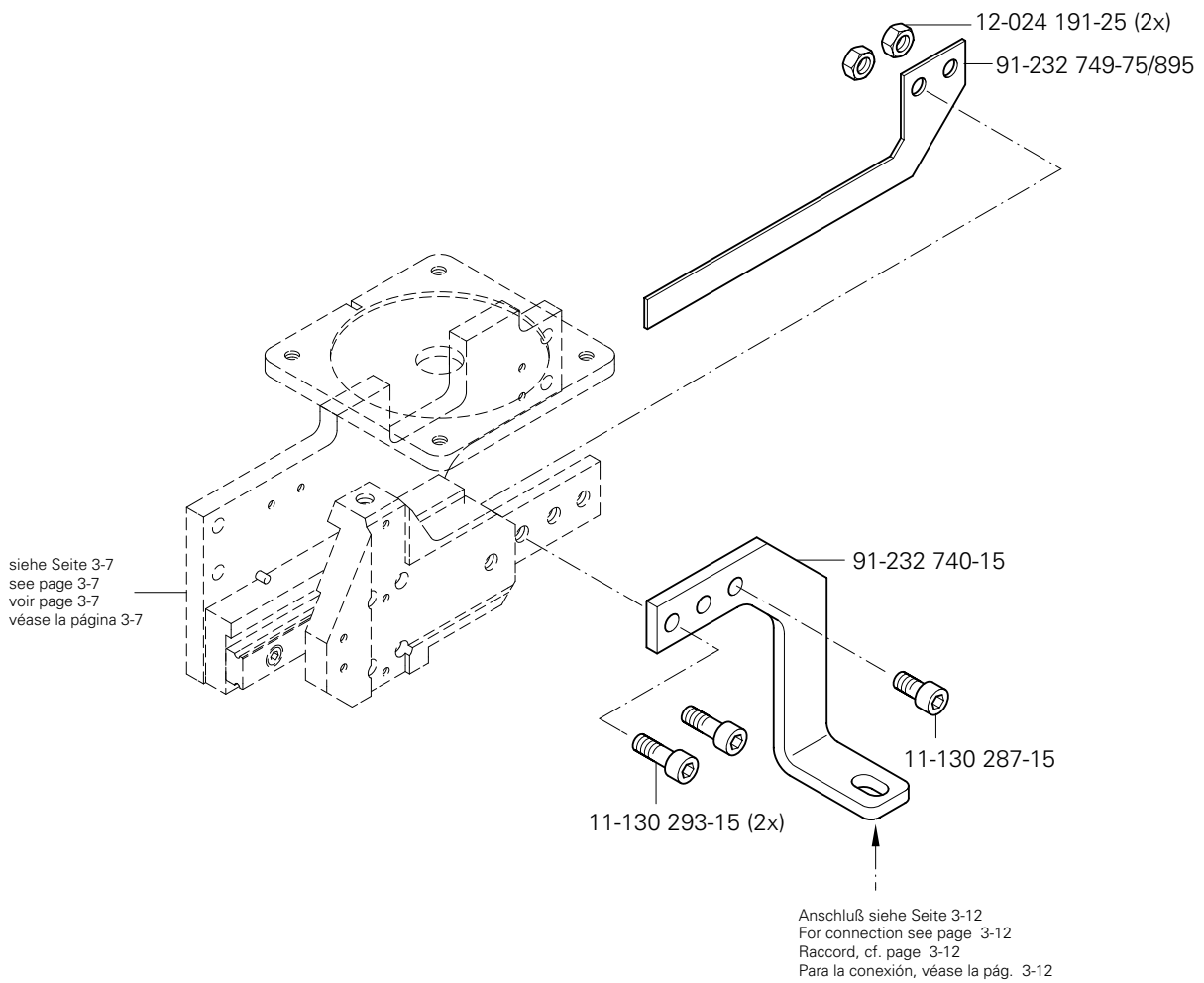
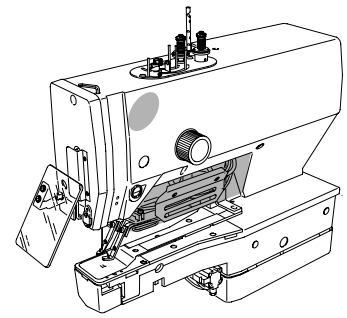

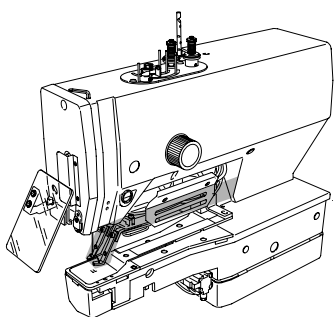

91-232 770-91
 (PFAFF 3307 -1/01; -1/02; -1/03; -3/01; -5/01)
 für -1/11 siehe Seite 10-5
 for -1/11 see page 10-5
 pour -1/11 voir page 10-5
 para -1/11 véase la página 10-5

11-039 179-15 (3x)

91-164 296-15 (3x)

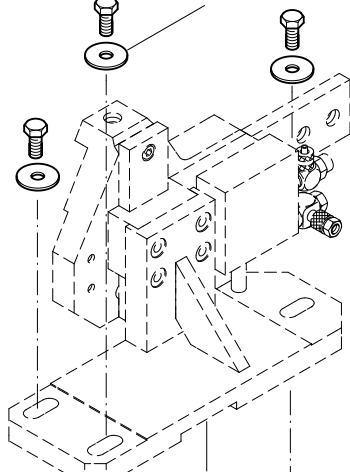

siehe Seite 3-7
 see page 3-7
 voir page 3-7
 véase la página 3-7

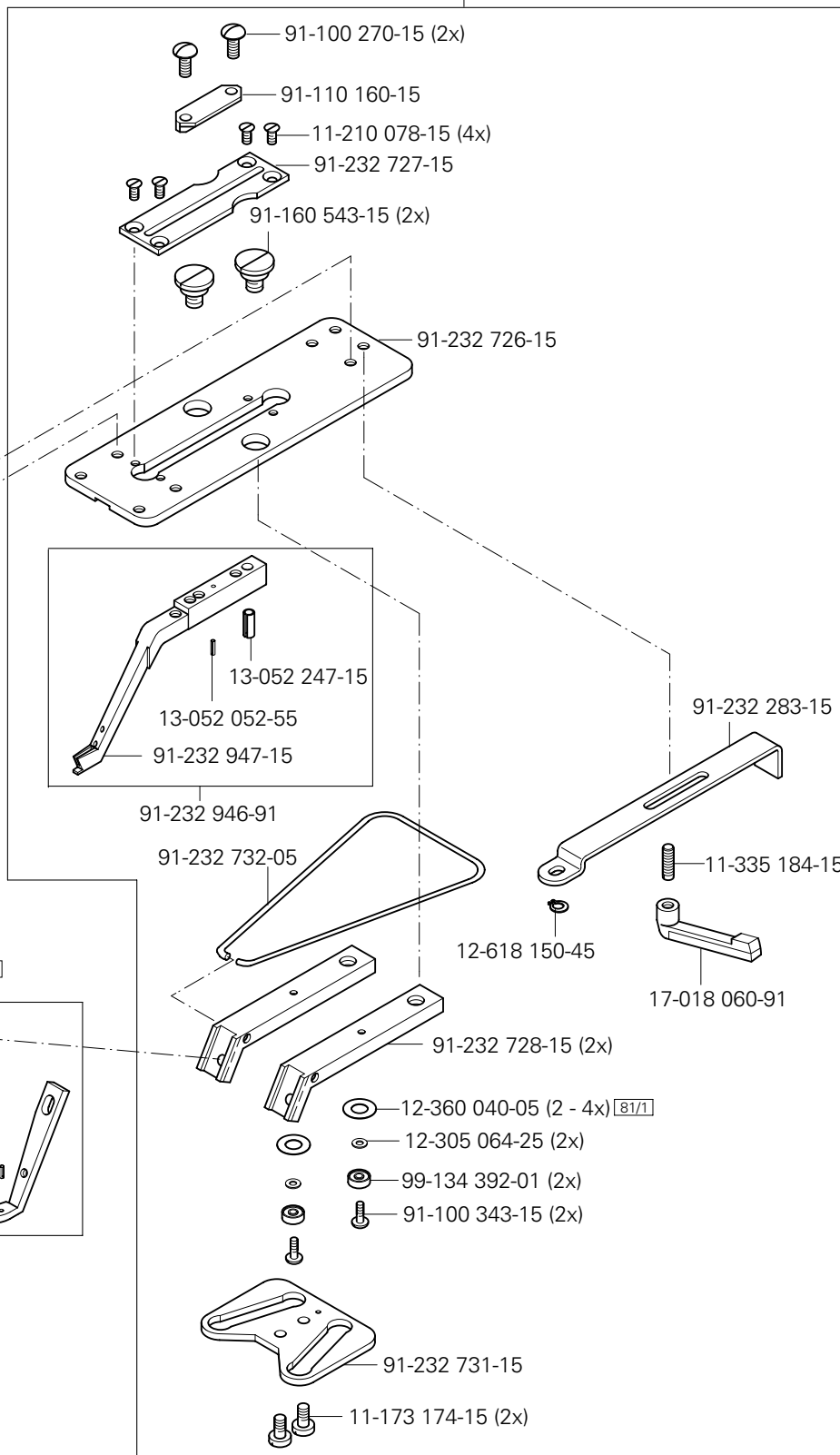

11-130 173-15 (2x)

12-305 114-15 (2x)

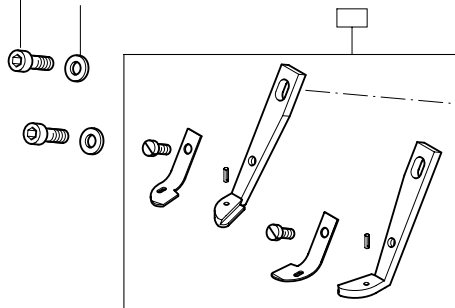

3.03

Armteile Arm parts Pièces de bras Piezas del brazo PFAFF 3307

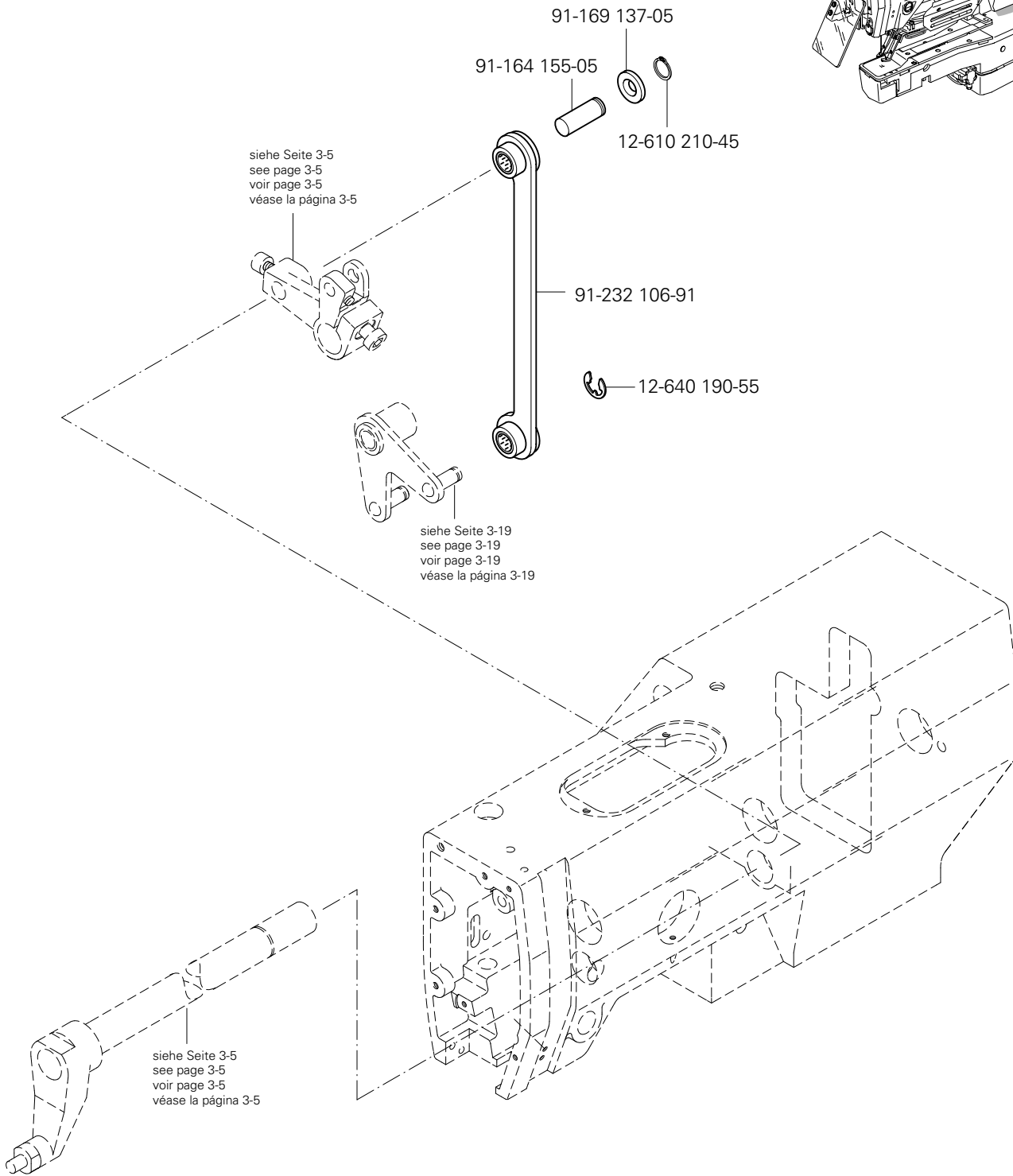
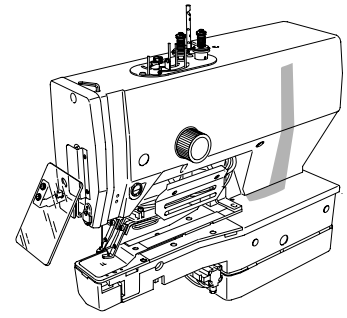

Freiarmteile
 Cylinder bed parts
 Pièces du bras inférieur
 Piezas del brazo al aire

PFAFF 3307

3.04

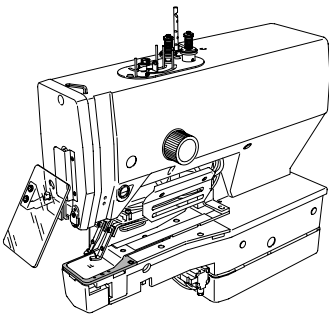

91-232 678-91 für -3/01; -9/01 siehe Seite 11-9 und 13-3
 for -3/01; -9/01 see page 11-9 and 13-3
 pour -3/01; -9/01 voir page 11-9 et 13-3
 para -3/01; -9/01 véase la página 11-9 y 13-3

91-000 250-15 (2x)

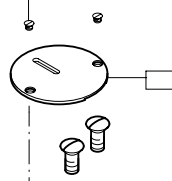

91-100 296-25 (3x)

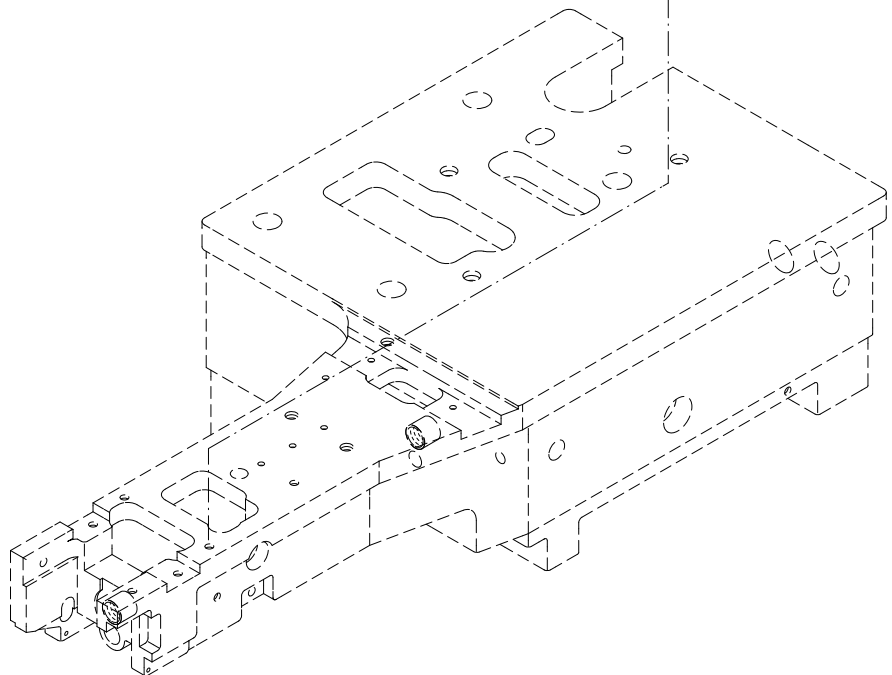
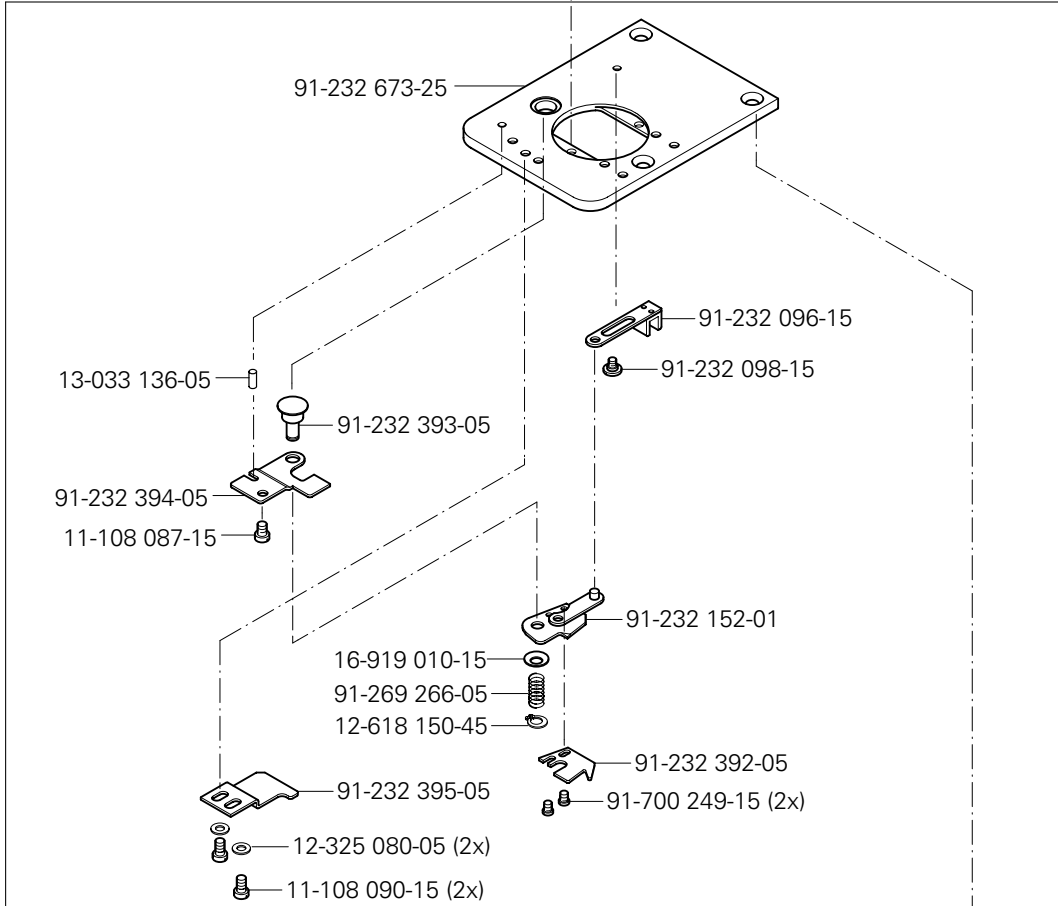

3.04

Freiarmteile
Cylinder bed parts
Pièces du bras inférieur
Piezas del brazo al aire

PFAFF 3307

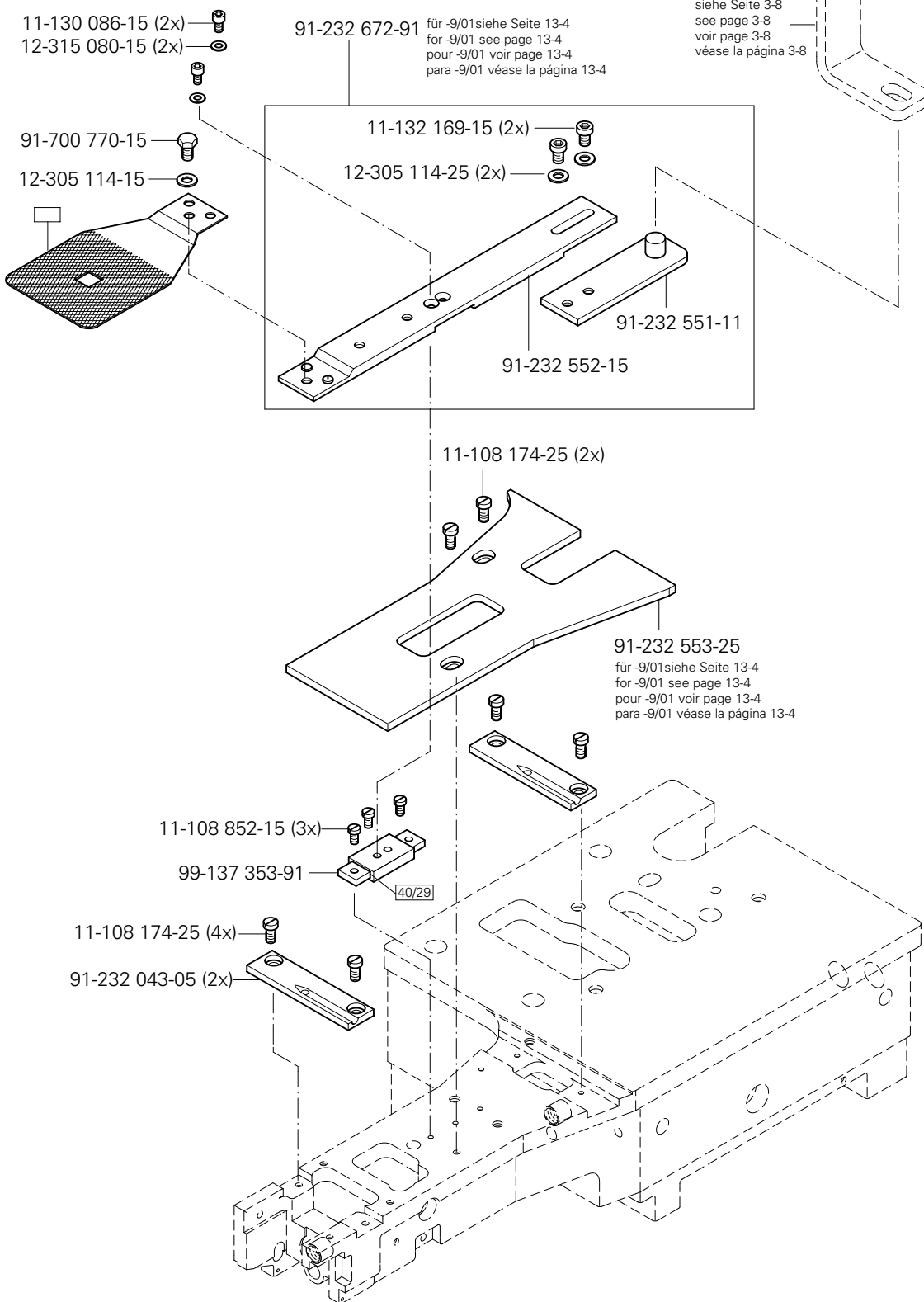
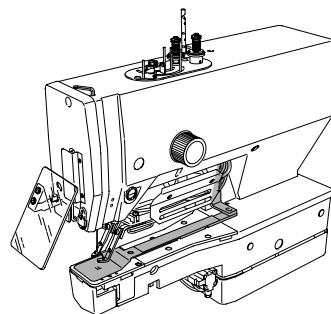

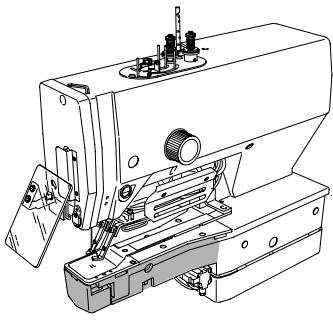

Freiarmteile
Cylinder bed parts
Pièces du bras inférieur
Piezas del brazo al aire

PFAFF 3307

3.04

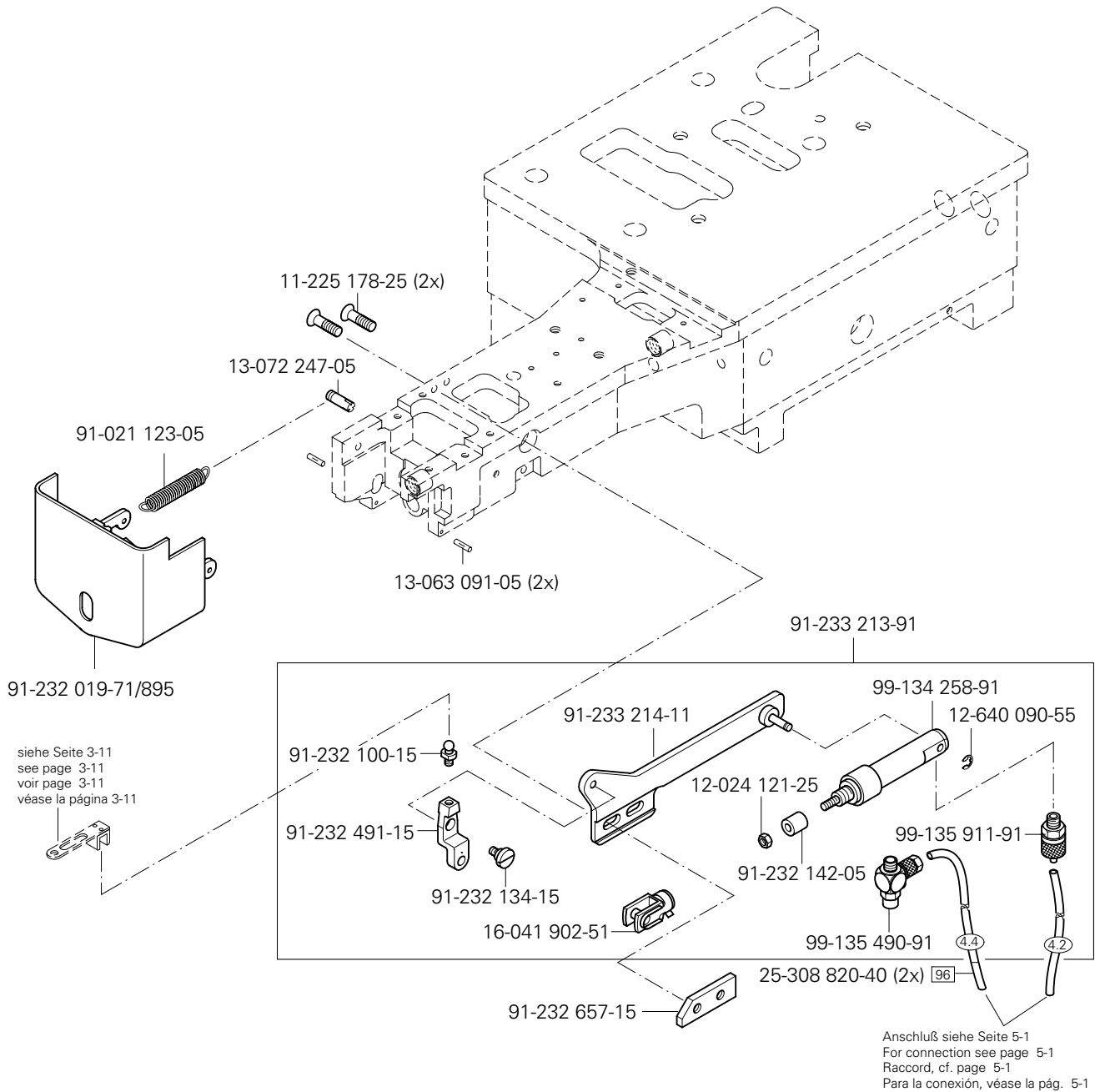

3.04

Freiarmteile Cylinder bed parts Pièces du bras inférieur Piezas del brazo al aire

PFAFF 3307

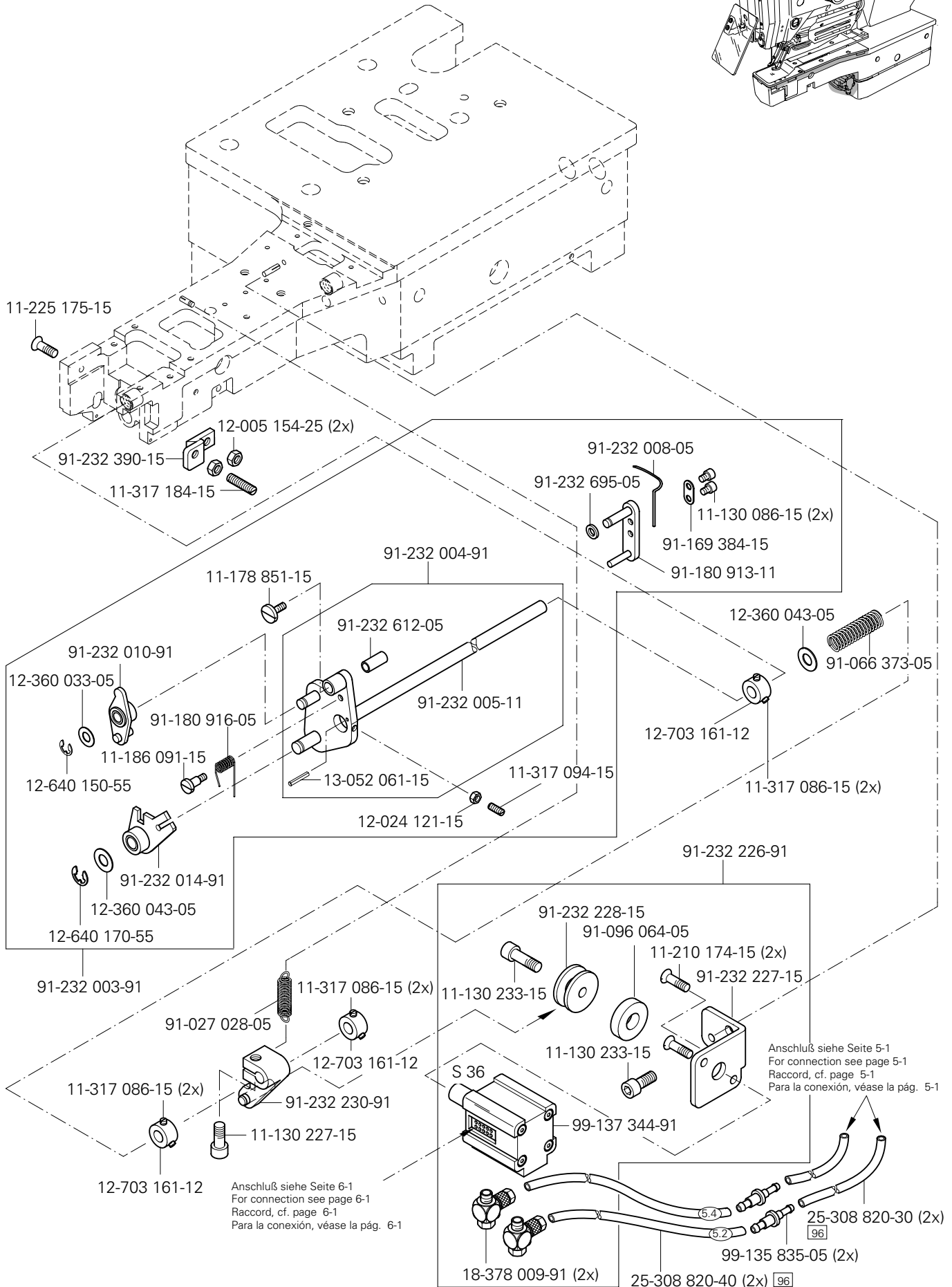
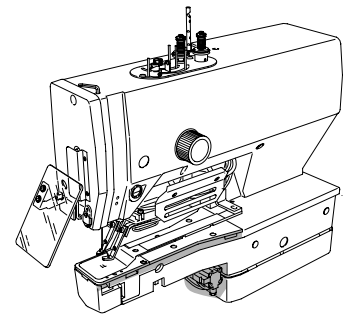

Freiarmteile
 Cylinder bed parts
 Pièces du bras inférieur
 Piezas del brazo al aire

PFAFF 3307

3.04

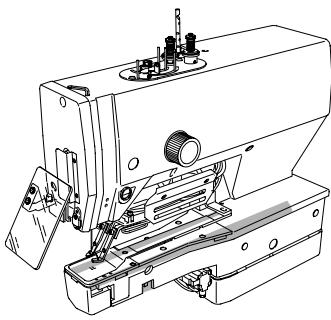

siehe Seite 3-18
 see page 3-18
 voir page 3-18
 véase la página 3-18

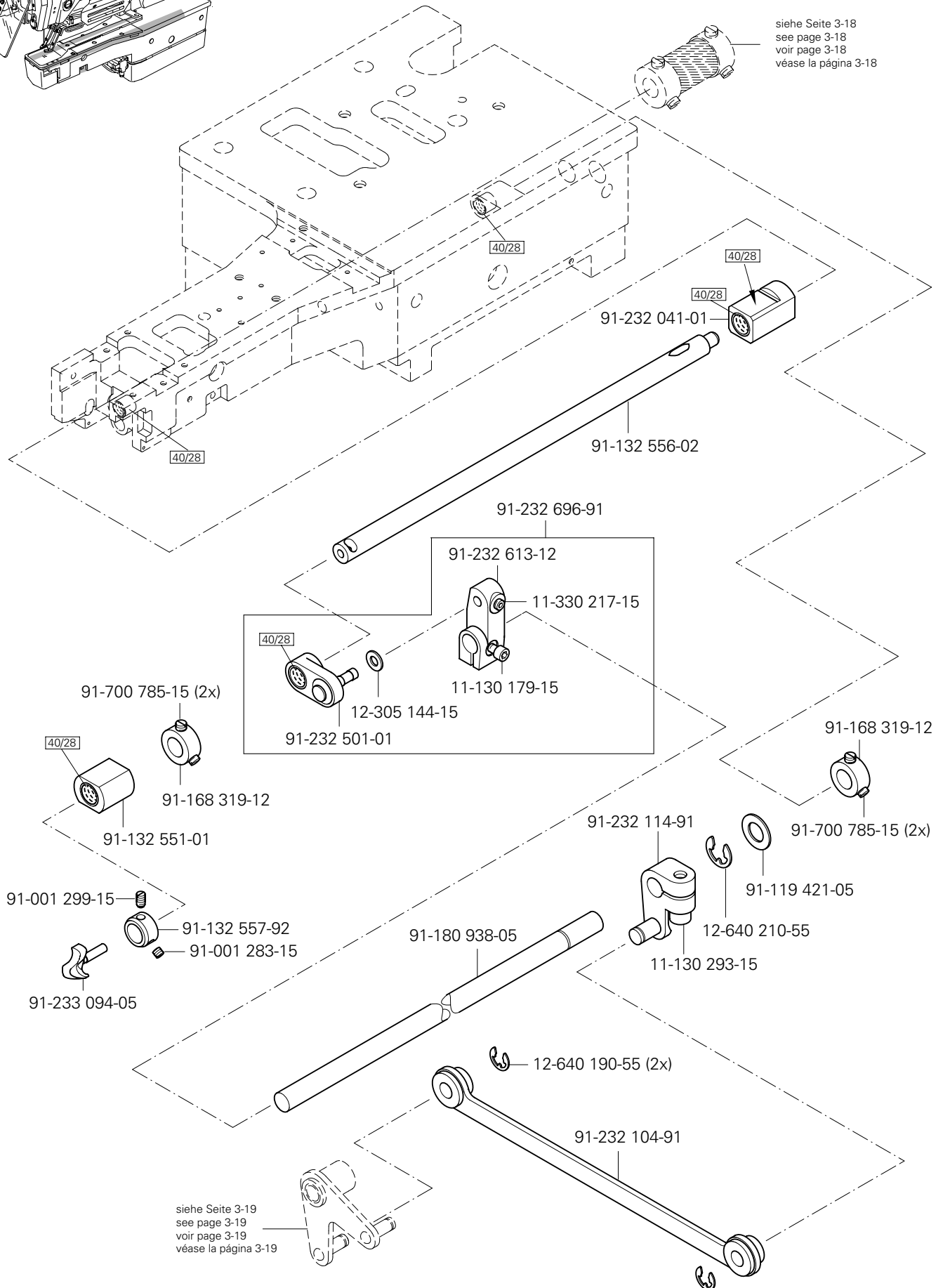

3.04

Freiarmteile
Cylinder bed parts
Pièces du bras inférieur
Piezas del brazo al aire

PFAFF 3307

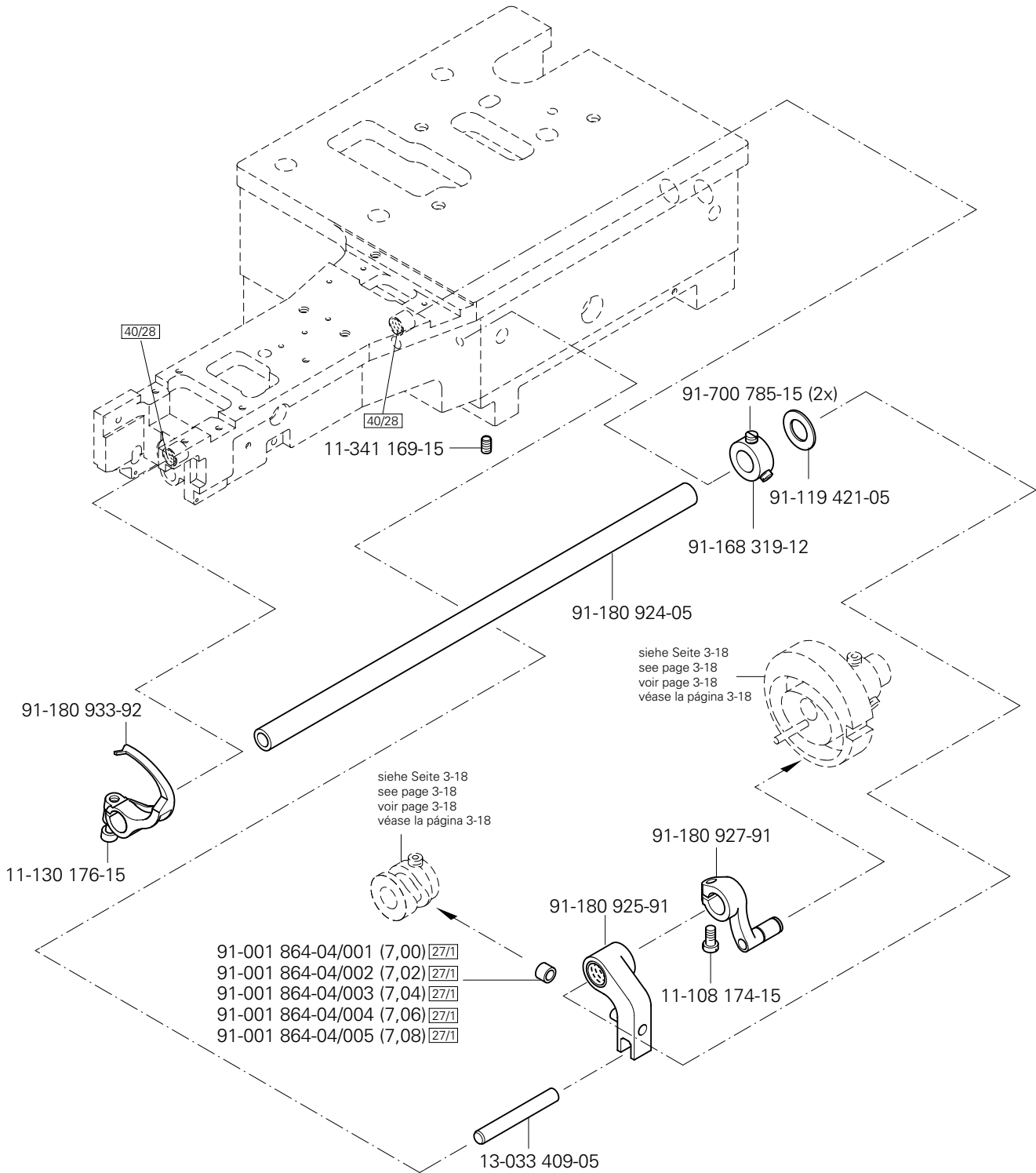
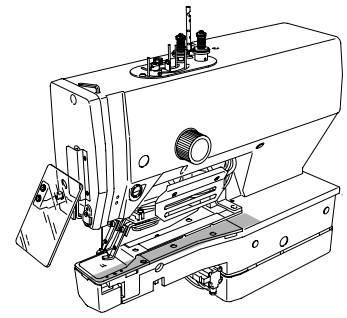

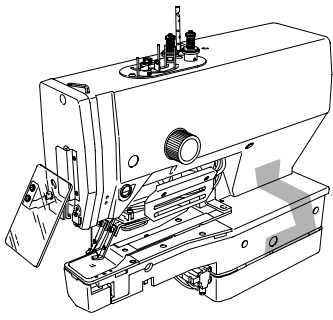

Freiarmteile
 Cylinder bed parts
 Pièces du bras inférieur
 Piezas del brazo al aire

PFAFF 3307

3.04

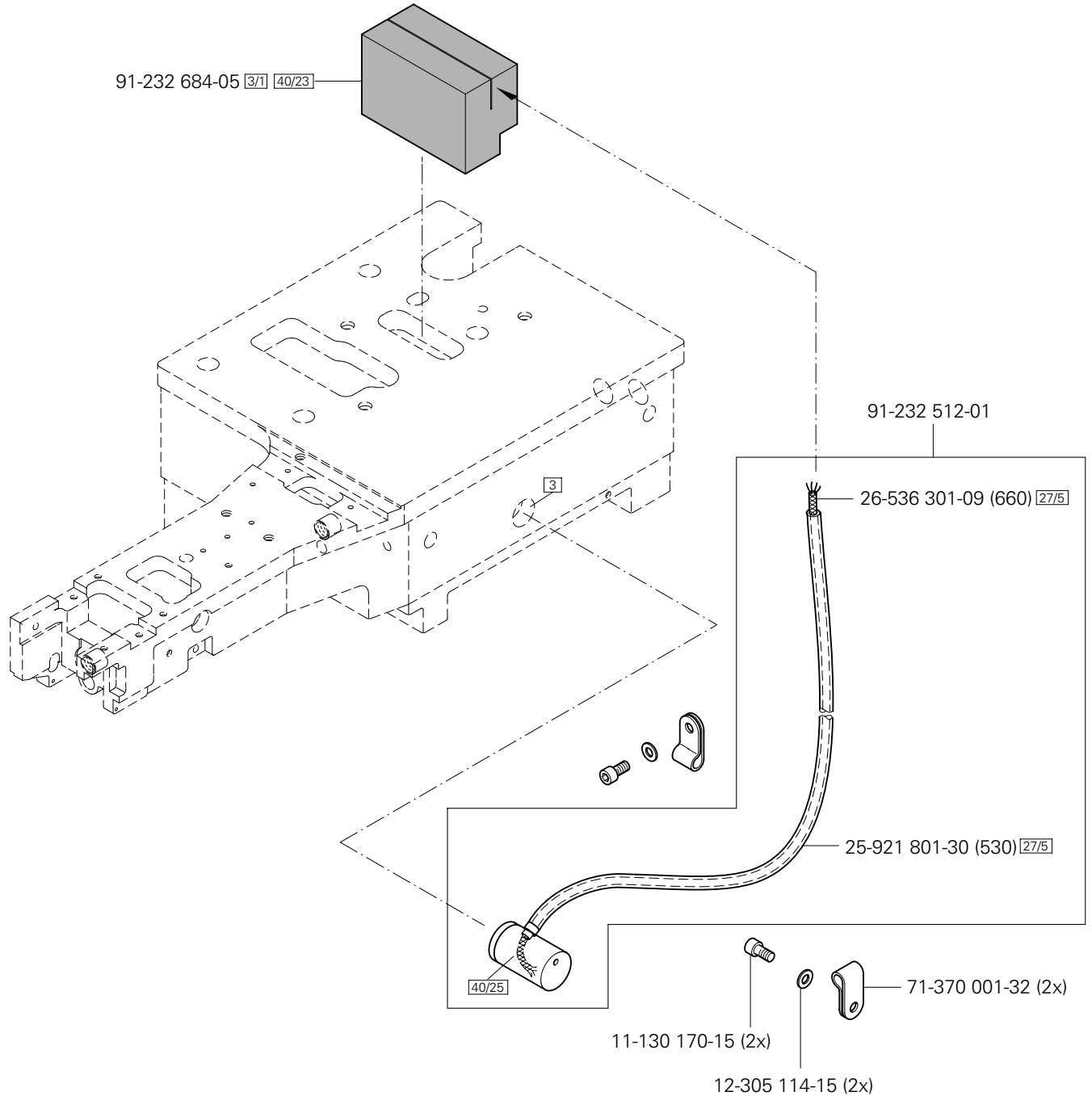

3.04

Freiarnteile
Cylinder bed parts
Pièces du bras inférieur
Piezas del brazo al aire

PFAFF 3307

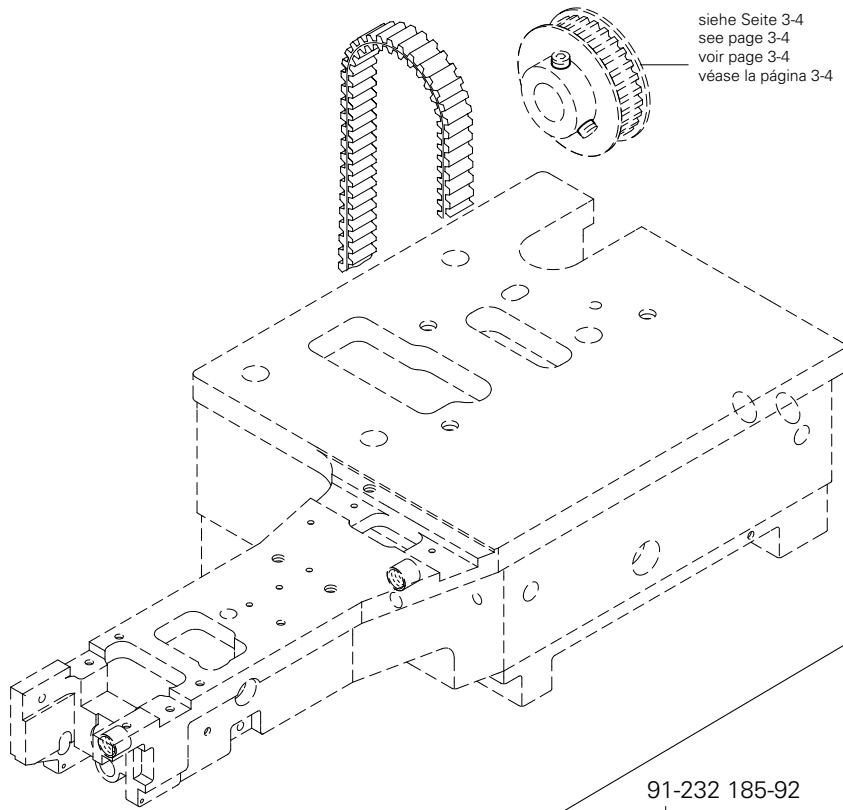
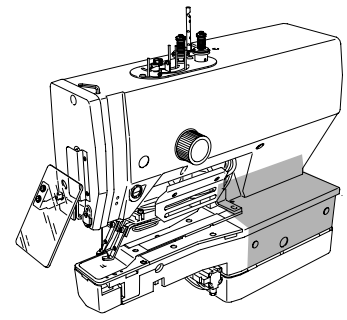

siehe Seite 3-4
see page 3-4
voir page 3-4
véase la página 3-4

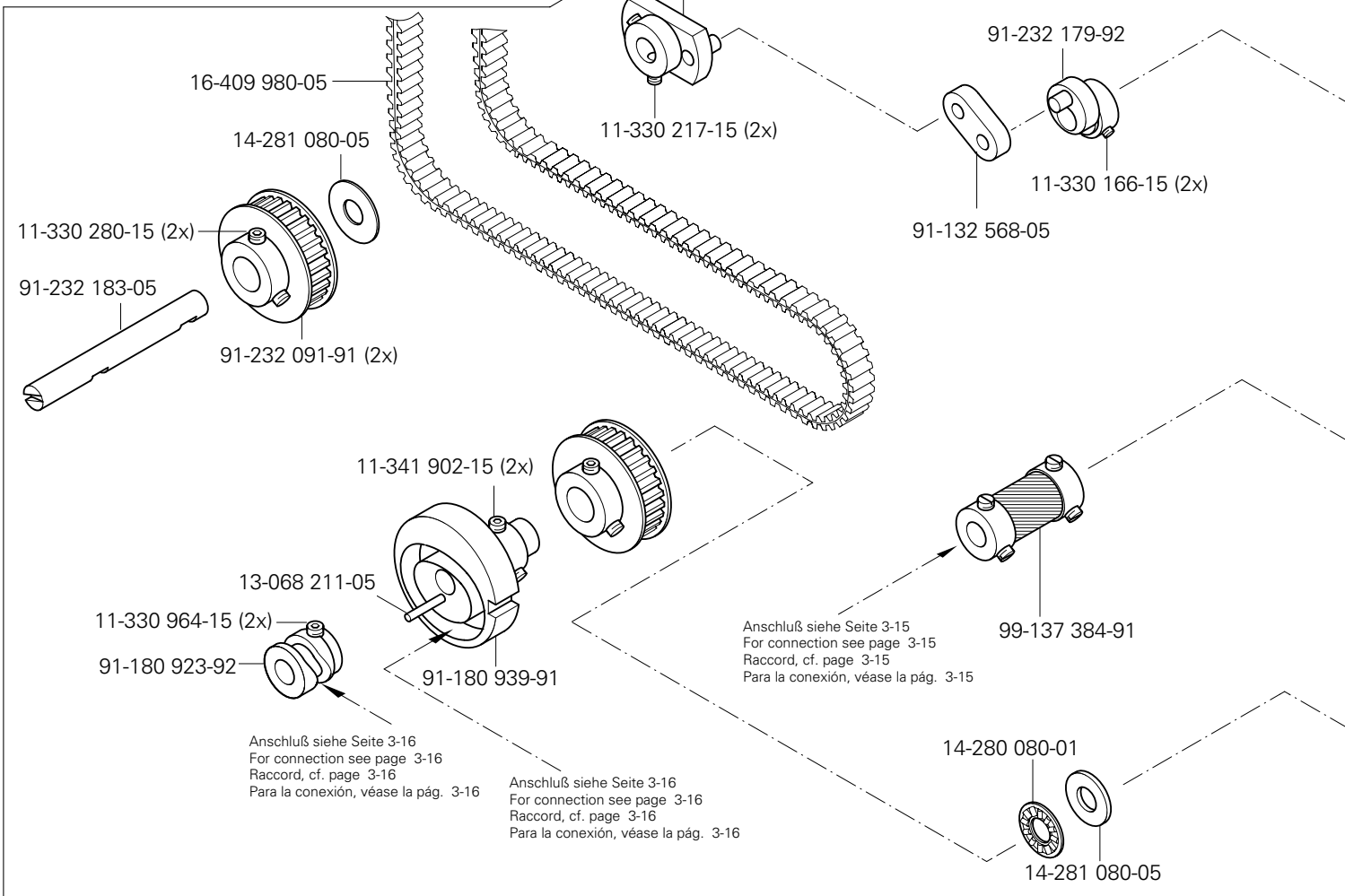

Anschluß siehe Seite 3-15
For connection see page 3-15
Raccord, cf. page 3-15
Para la conexión, véase la pág. 3-15

Anschluß siehe Seite 3-16
For connection see page 3-16
Raccord, cf. page 3-16
Para la conexión, véase la pág. 3-16

Anschluß siehe Seite 3-16
For connection see page 3-16
Raccord, cf. page 3-16
Para la conexión, véase la pág. 3-16

Freiarmteile
 Cylinder bed parts
 Pièces du bras inférieur
 Piezas del brazo al aire

PFAFF 3307

3.04

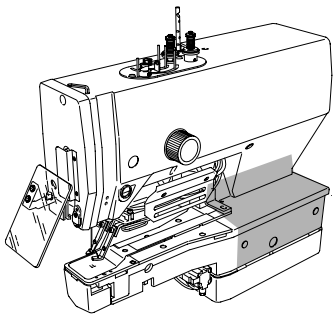

91-232 207-91

12-640 190-55

Anschluß siehe Seite 3-10
 For connection see page 3-10
 Raccord, cf. page 3-10
 Para la conexión, véase la pág. 3-10

91-232 180-05

11-330 952-15 (2x)

91-232 445-92

Anschluß siehe Seite 3-15
 For connection see page 3-15
 Raccord, cf. page 3-15
 Para la conexión, véase la pág. 3-15

91-232 101-11

91-232 187-05

12-024 231-15

91-232 116-91

12-305 264-15

11-330 226-15 (2x)

16-409 979-05

11-330 952-15 (2x)

91-232 445-92

91-232 361-92 (3x)

14-280 080-01

14-281 080-05

11-330 952-15

91-232 188-05

91-232 044-91

15-711 050-51
40/28

91-232 045-05

11-130 371-15 (2x)

11-330 968-91

11-130 365-15

4

Wartungseinheit (-925/03)
 Air filter/ lubricator (-925/03)
 Conditionneur d'air comprimé (-925/03)
 Grupo acondicionador del aire comprimido (-925/03) PFAFF 3307

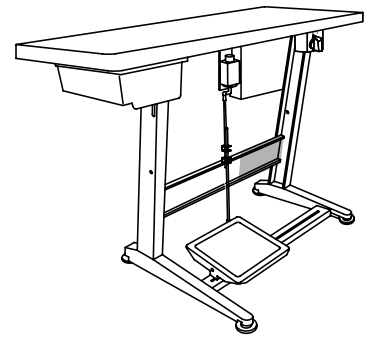

91-187 426-70/893

25-308 820-40

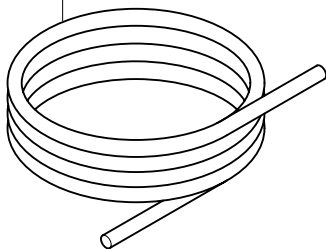

91-187 386-15

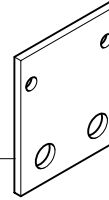

12-335 191-15 (2x)



11-130 305-15 (2x)

99-136 546-91

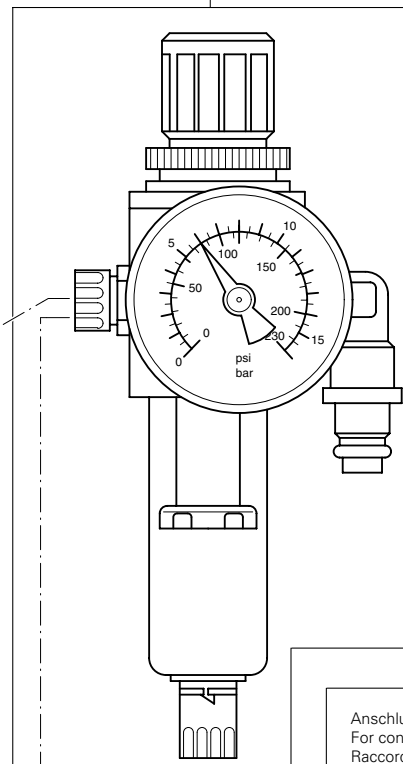

15-032 002-45

18-372 003-91

Anschluß siehe Seite 3-7 und 12-2
 For connection see page 3-7 and 12-2
 Raccord, cf. page 3-7 et 12-2
 Para la conexión, véase la pág. 3-7 y 12-2

(-1/11; -3/01)

Anschluß siehe Seite 10-7 und 11-10
 For connection see page 10-7 and 11-10
 Raccord, cf. page 10-7 et 11-10
 Para la conexión, véase la pág. 10-7 y 11-10

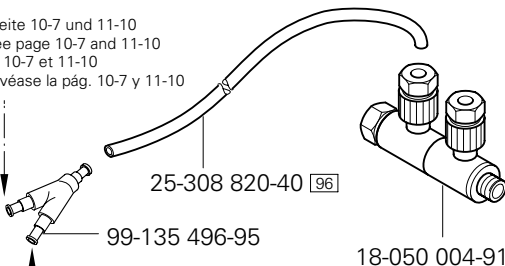

Anschluß siehe Seite 10-9
 For connection see page 10-9
 Raccord, cf. page 10-9
 Para la conexión, véase la pág. 10-9

Anschluß siehe Seite 5-1
 For connection see page 5-1
 Raccord, cf. page 5-1
 Para la conexión, véase la pág. 5-1

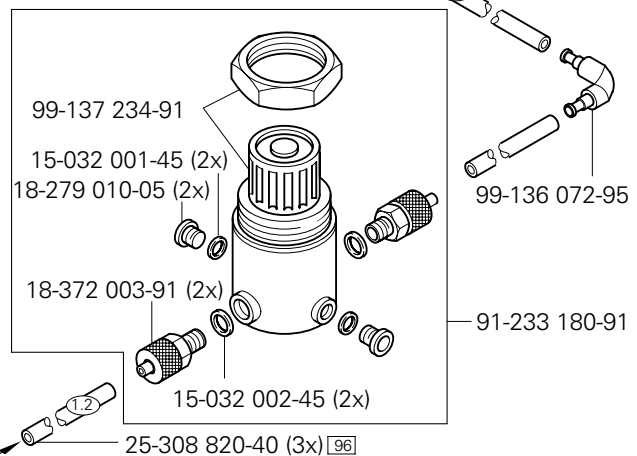

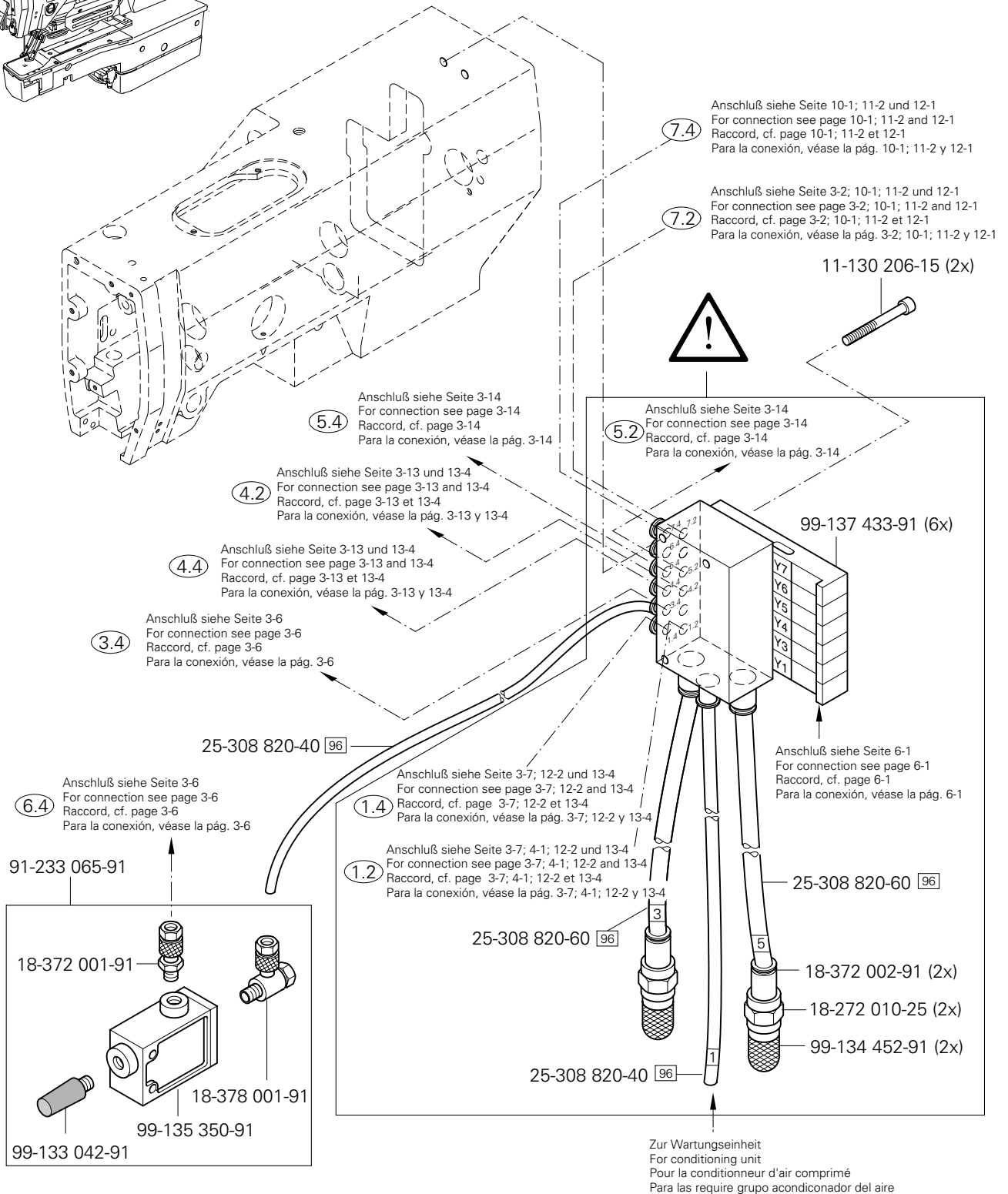
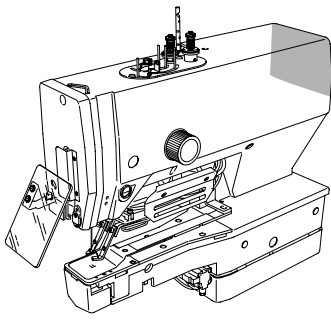

Beschriftung der Ventile beachten!
 Observe valve markings!

Tenir complet de l'inscription sur les vannes!
 ¡Observe las inscripciones en las válvulas!

SMC = 91-233 200-91
 Bürkert = 91-233 023-91

6.01

Kabelbaum zum Oberteil Cable tree to sewing head Faisceau de câbles vers la tête de machine Mazo de cables para el cabezal

PFAFF 3307

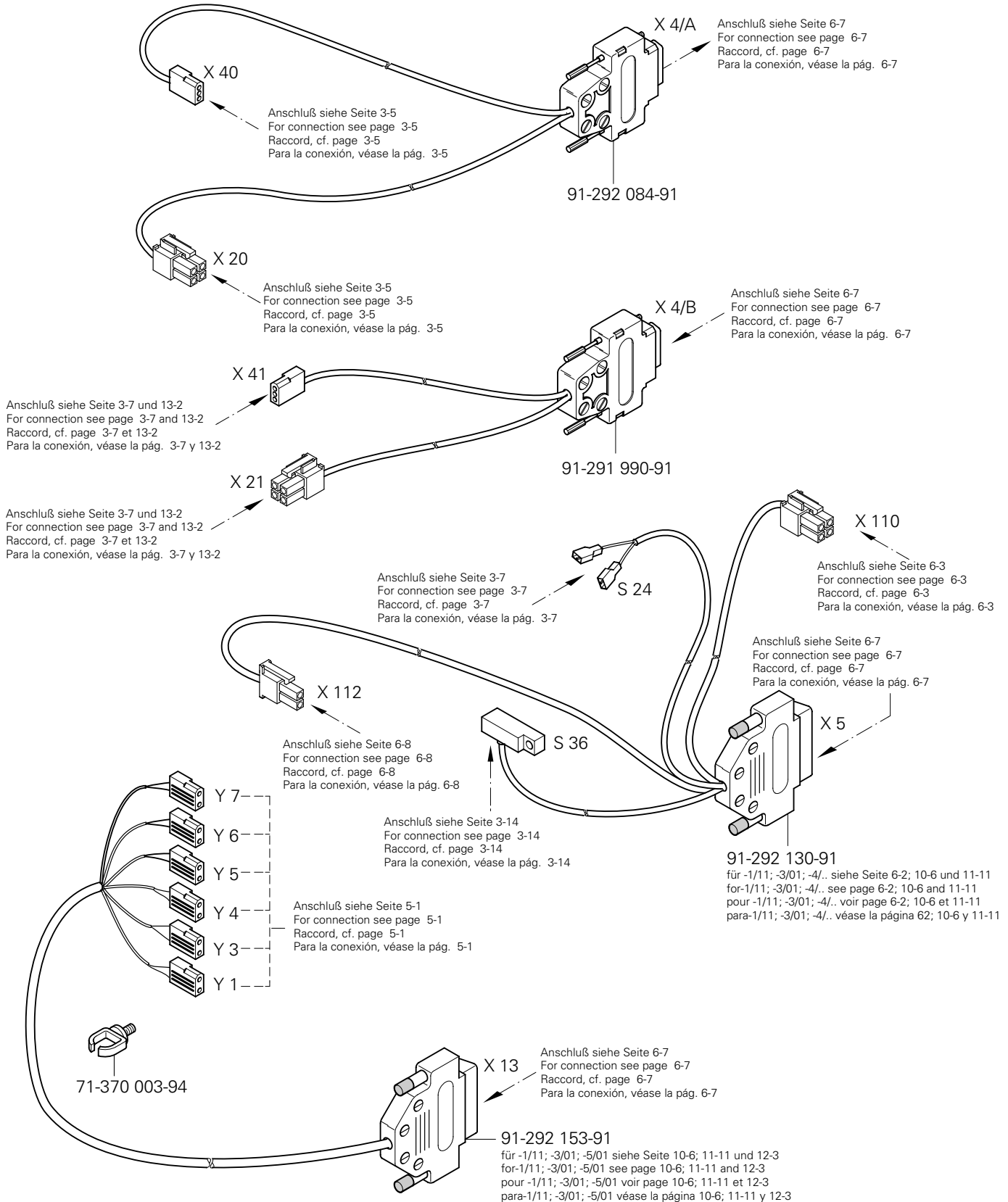
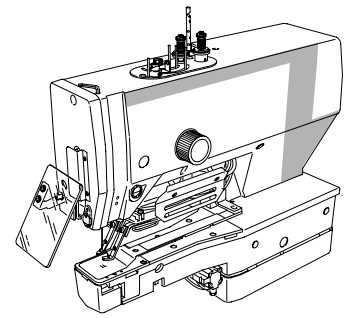

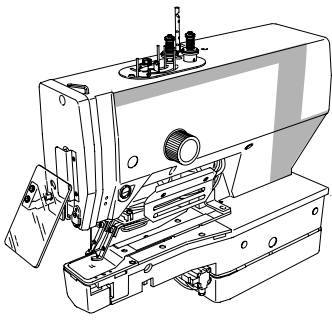

Kabelbaum zum Oberteil
Cable tree to sewing head
Faisceau de câbles vers la tête de machine
Mazo de cables para el cabezal

PFAFF 3307

6.01

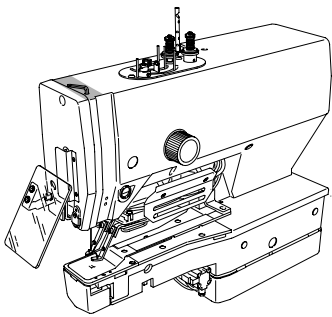
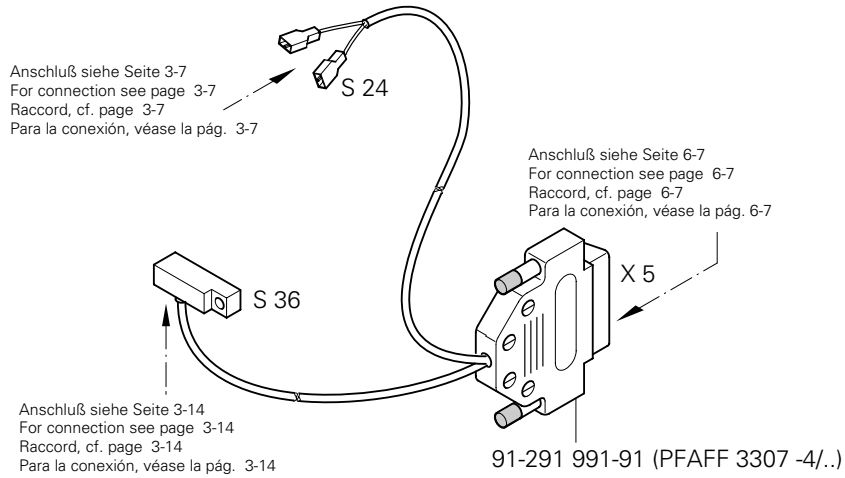

Fadenkraft-Sensor
Thread strength-sensor
Détecteur de la force du fil
Sensor-fuerza de hilo

PFAFF 3307-1/..
 PFAFF 3307-3/..
 PFAFF 3307-5/..

6.02

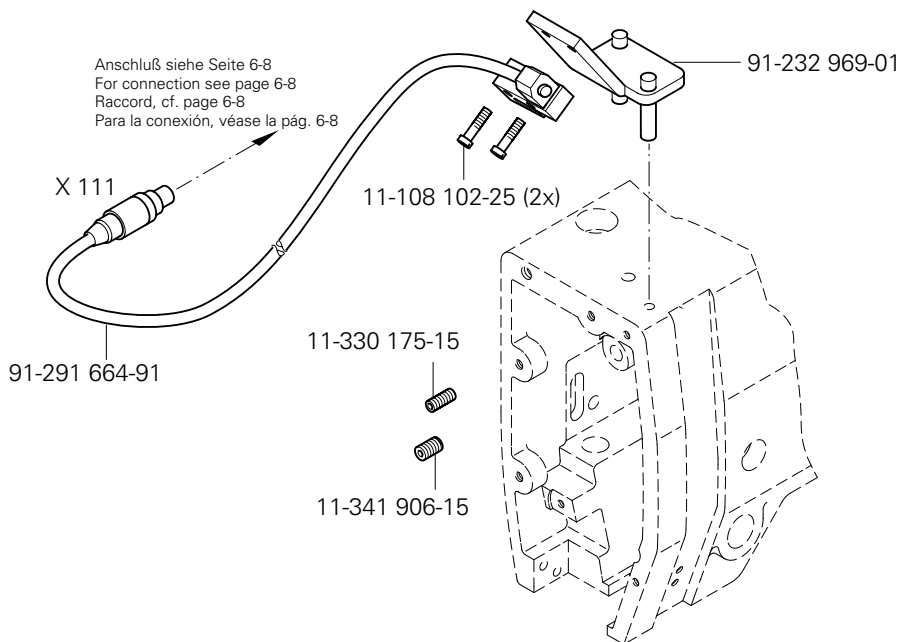

6.03

Tastschalter
Push-button switch
Interrupteur à bouton-poussoir
Interruptor pulsador

PFAFF 3307

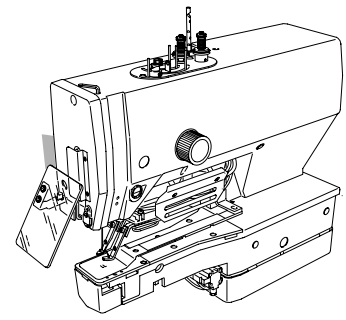

Anschluß siehe Seite 6-1
For connection see page 6-1
Raccord, cf. page 6-1
Para la conexión, véase la pág. 6-1

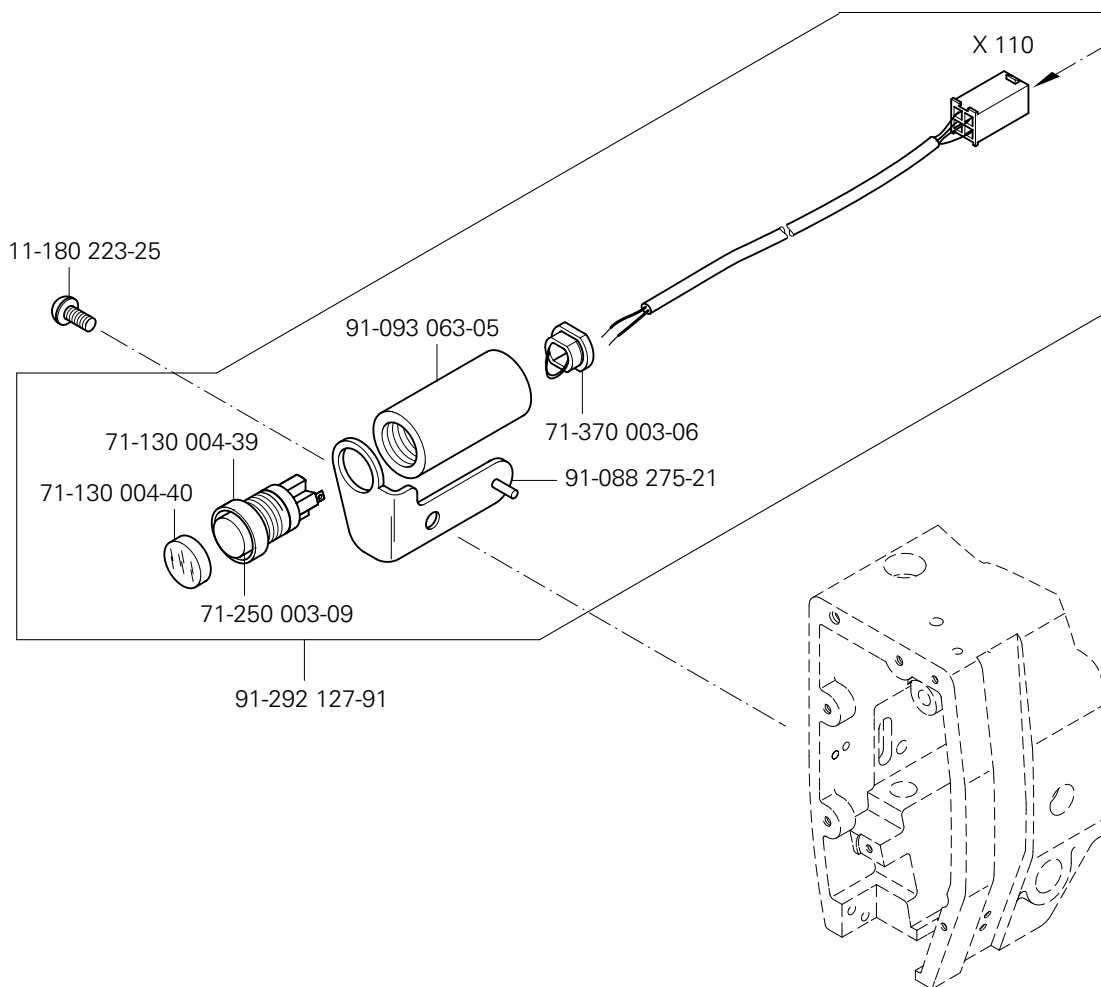

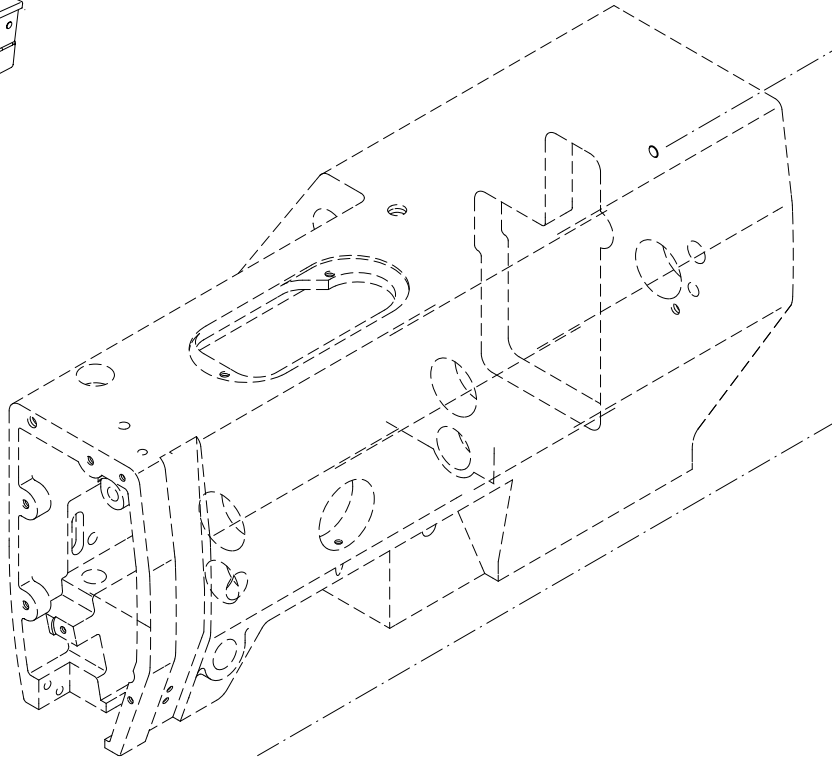
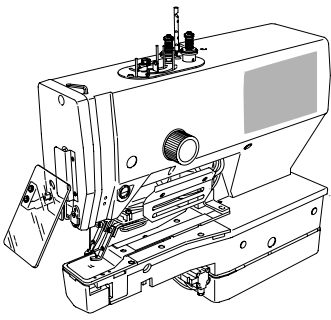

siehe Seite 3-4
 see page 3-4
 voir page 3-4
 véase la página 3-4

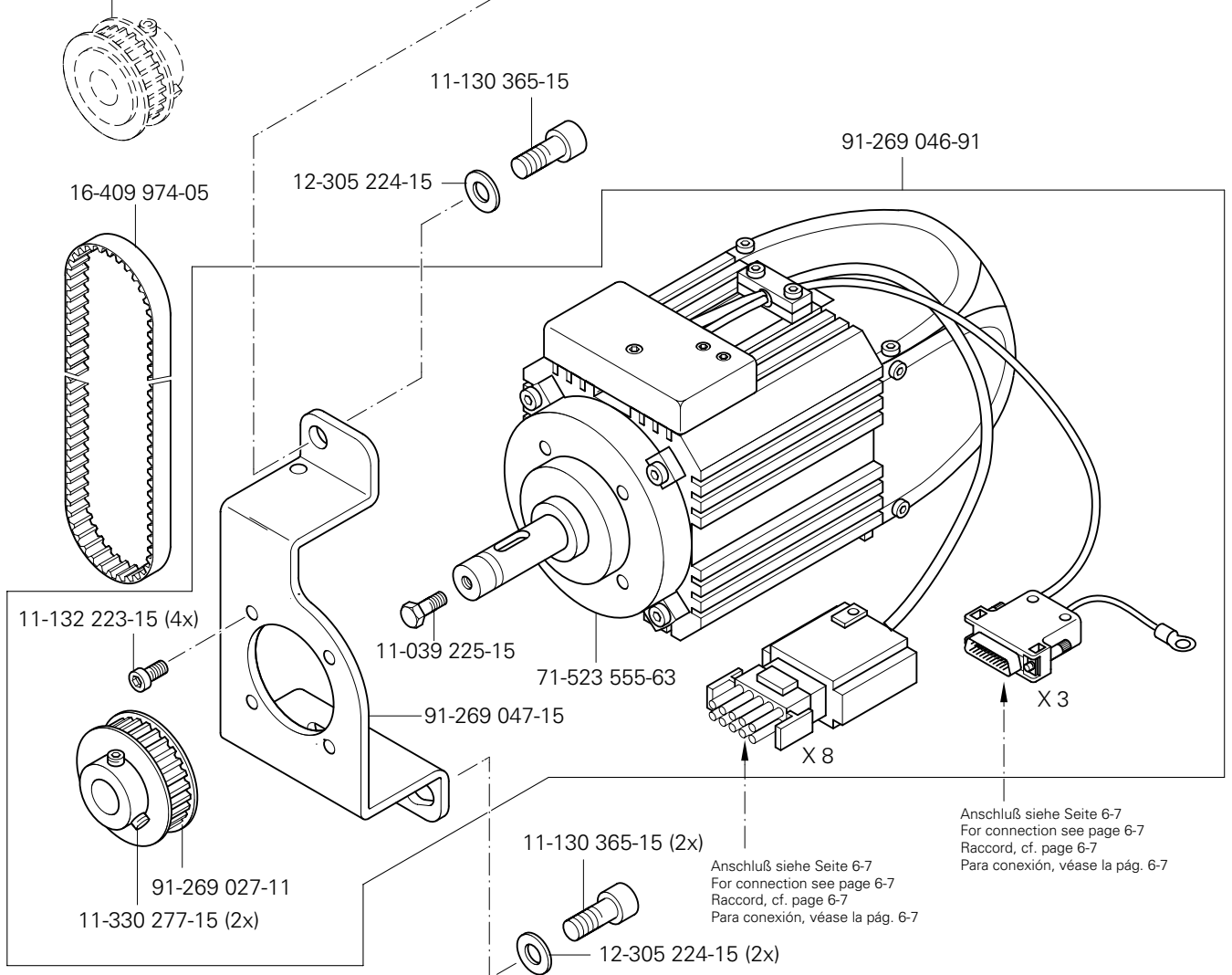

Anschluß siehe Seite 6-7
 For connection see page 6-7
 Raccord, cf. page 6-7
 Para conexión, véase la pág. 6-7

Anschluß siehe Seite 6-7
 For connection see page 6-7
 Raccord, cf. page 6-7
 Para conexión, véase la pág. 6-7

6.05

Bedienfeld
Control panel
Panne au de commande
Panel de mandos

PFAFF 3307

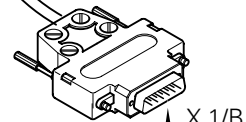
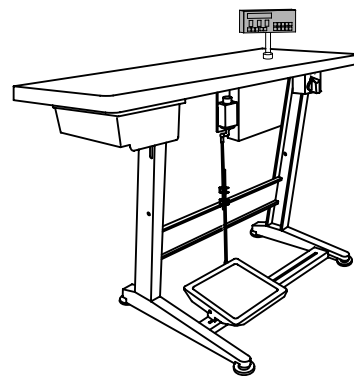
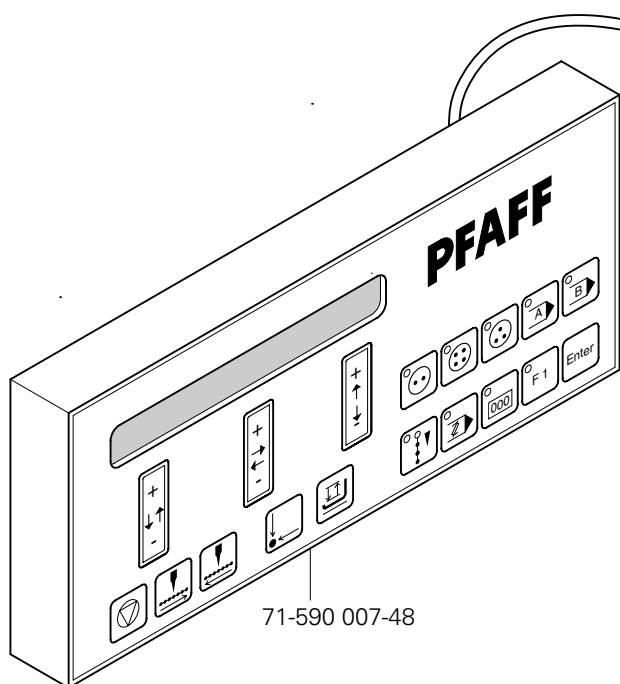

Anschluß siehe Seite 6-7
For connection see page 6-7
Raccord, cf. page 6-7
Para la conexión, véase la pág. 6-7

6.06

Motor-Hauptschalter
Main switch
Interrupteur général
Interruptor principal

PFAFF 3307

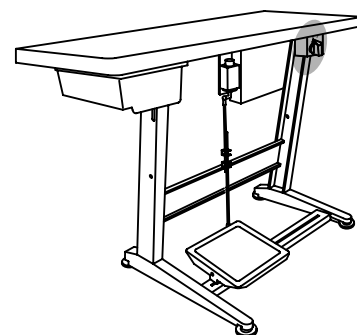

71-370 001-08



11-460 163-15 (2x)



71-370 002-92

91-229 180-90 ^{90/1}

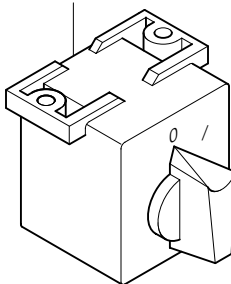

11-462 250-55 (2x)

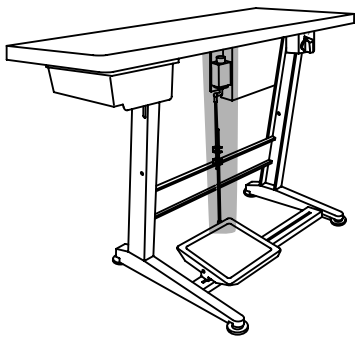

Sollwertgeber
Set-point generator
Codeur
Emisor del valor teórico PFAFF 3307

6.07

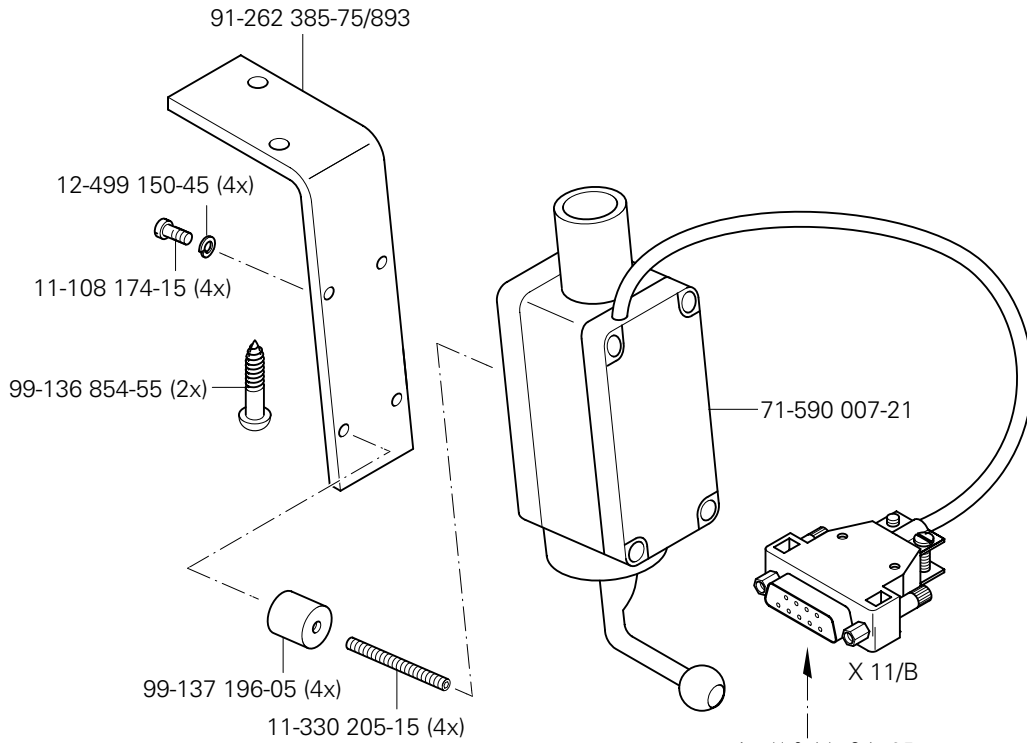

Anschluß siehe Seite 6-7
For connection see page 6-7
Raccordo, cf. page 6-7
Para la conexión, véase la pág. 6-7

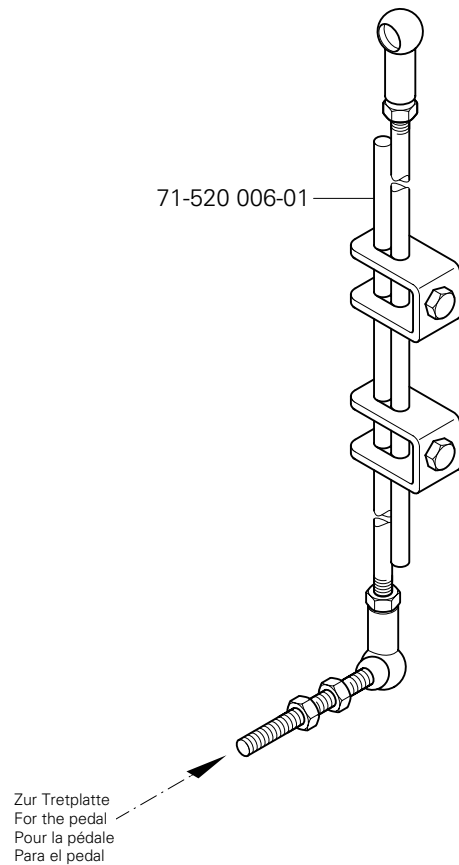

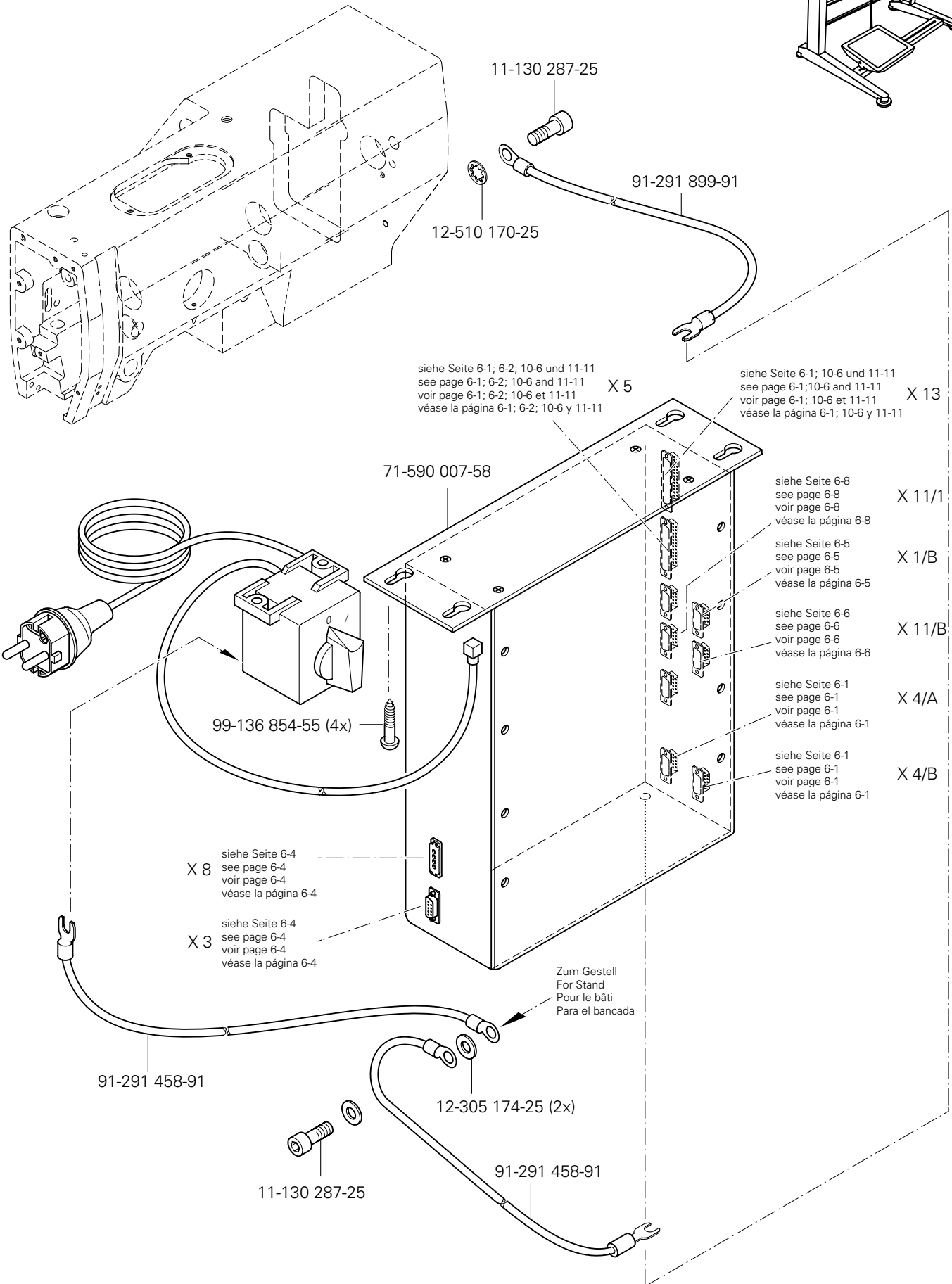
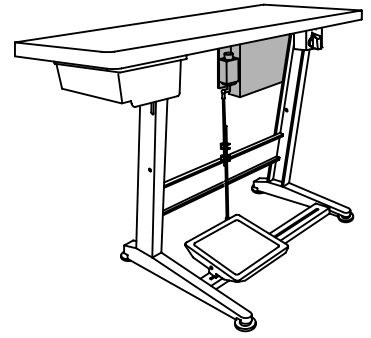

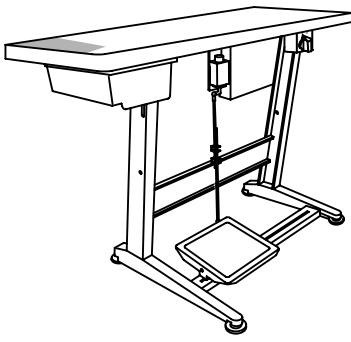

Steuergerät
Control device PFAFF 3307-1../
Boîte de commande PFAFF 3307-3../
Caja de mandos PFAFF 3307-5../

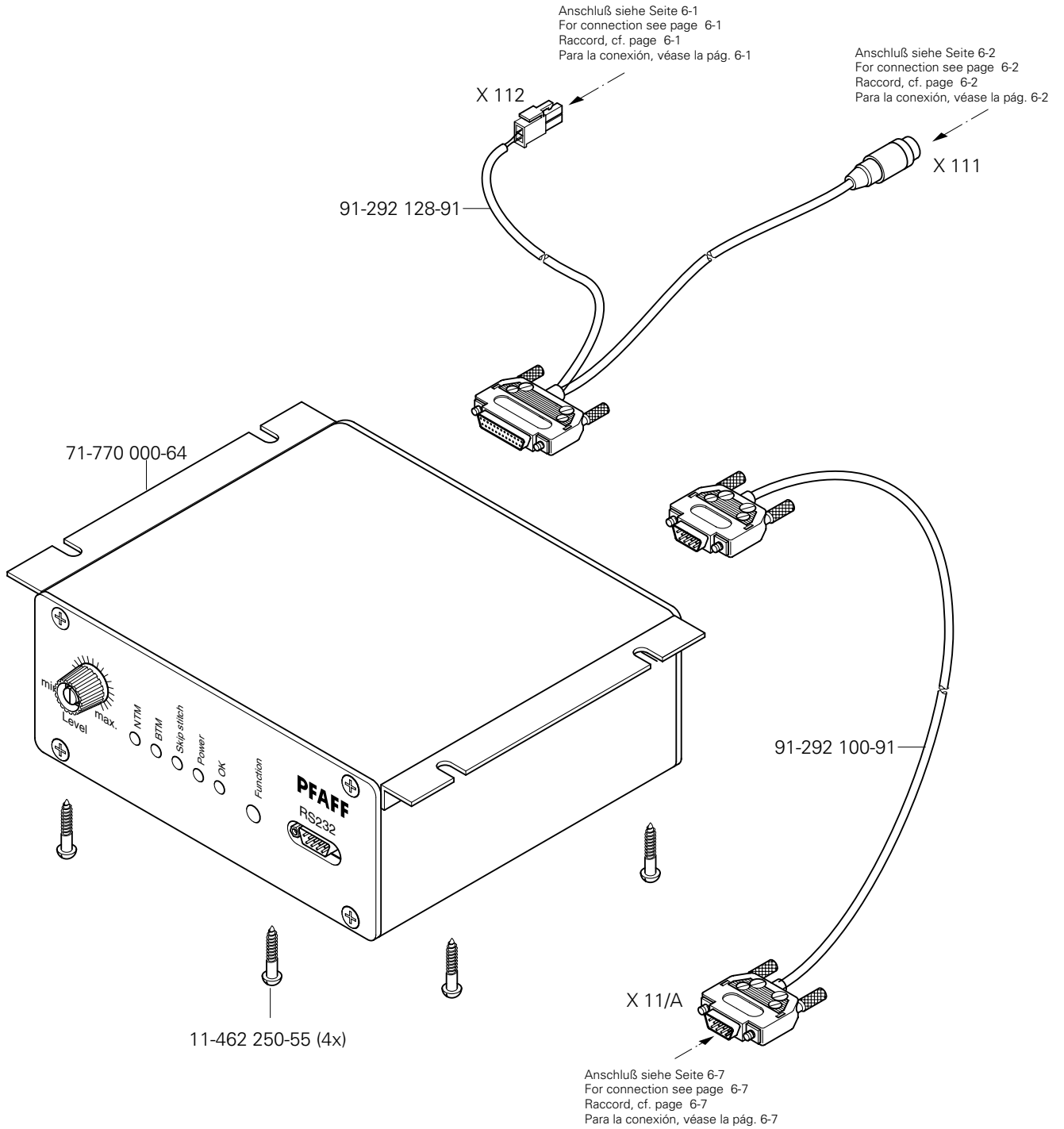

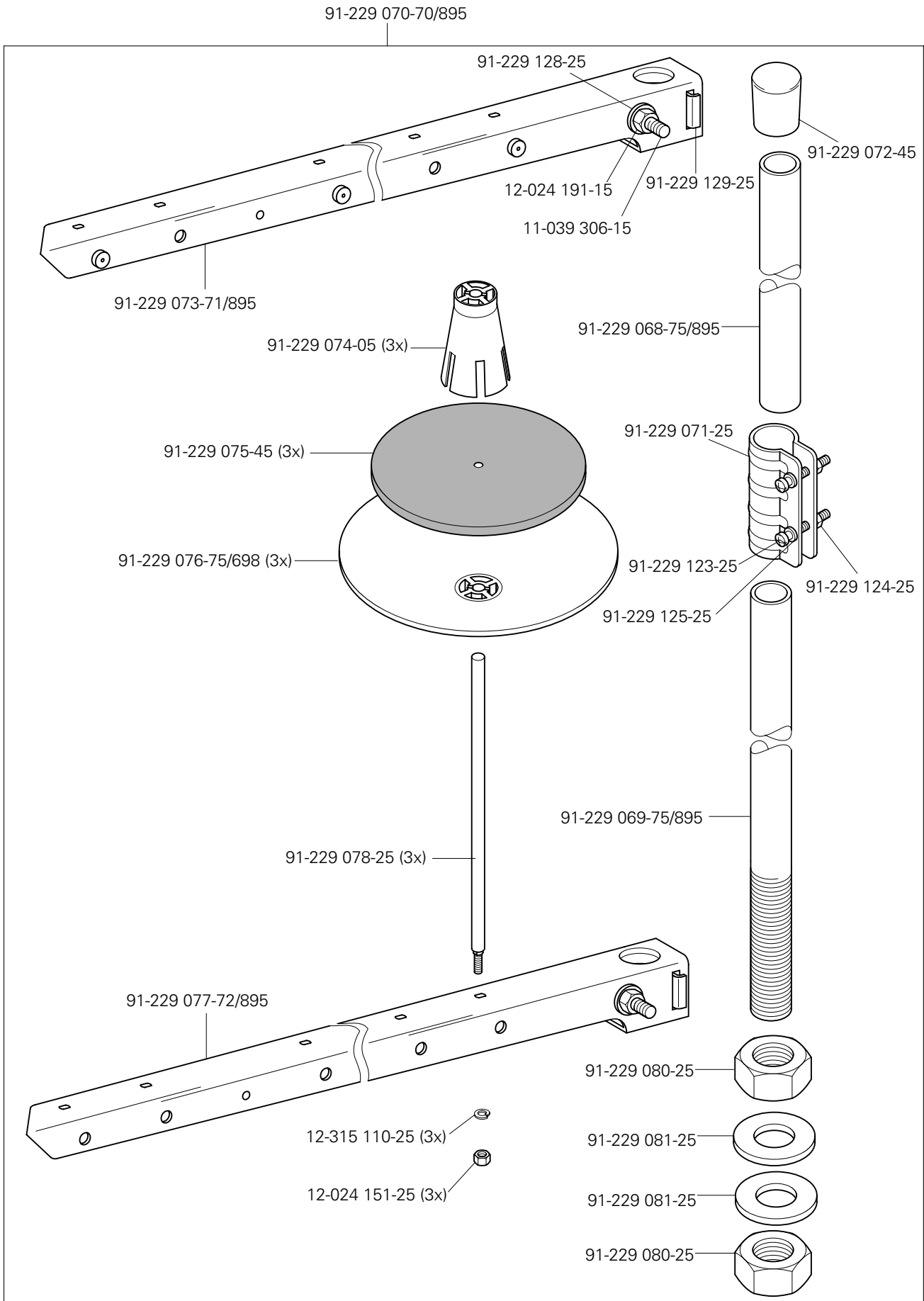

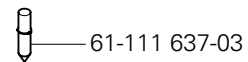
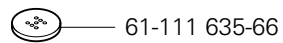
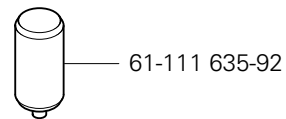
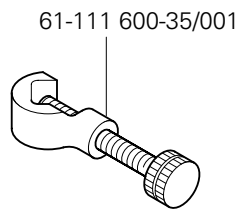
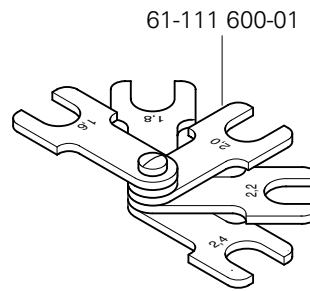
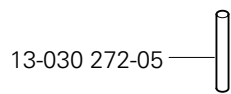

| Öl Oil Huile Aceite | Mittelpunkts-Viskosität bei: Mean viscosity at: Viscosité moyenne à: Viscosidad media a: | | Dichte bei: Density of: Densité à: Densidad a: | | Bestellnummer für Behälter mit: Part number for can with: Numéro de commande pour récipients avec: Número de pedido para recipientes con: | | |
|------------------------------|---|--------------------|---|-----------------------------|---|--------------------------------|-----------------------------------|
| | °C | mm ² /s | °C | g/cm ³ (g/ml) | 1 Liter 1 Litre 1 Litro | 5 Liter 5 Litre 5 Litros | 10 Liter 10 Litre 10 Litros |
| 28-011 201-45 | 40 | 31,0 | 15 | 0,870 | 91-232 877-91 | | |
| | | | | | | | |
| | | | | | | | |
| | | | | | | | |

| Fett Grease Graisse Grasa | Penetration Penetration Pénétration Penetración | Tropfpunkt Drip-point Point de suintement Punto de goteo | Bestellnummer für Behälter mit: Part number for can with: Numéro de commande pour récipients avec: Número de pedido para recipientes con: | | |
|------------------------------------|--|---|--|----|---------------|
| | | | mm/10 | °C | 0,25 kg |
| 28-011 202-10 | | 185 | | | 28-011 202-10 |
| 28-011 202-69 | | 170 | | | 28-011 202-69 |
| | | | | | |
| | | | | | |

| Reinigungsmittel Cleansing agent Agents de nettoyage Limpiadores | Bestellnummer für Behälter mit: Part number for can with: Numéro de commande pour récipients avec: Número de pedido para recipientes con: | | |
|---|--|--|--|
| | 240 ml | | |
| Isoprophyl-Alkohol | 95-665 735-91 | | |

Abweichende Teile der PFAFF 3307-1/11
Different parts for PFAFF 3307-1/11
Pièces divergentes de la PFAFF 3307-1/11
Piezas de la PFAFF 3307-1/11 que son diferentes

(die sonstigen Teile wie in Register 3 bis 9)

(for all other parts see Sections 3 to 9)

(les autres pièces comme dans les registres 3 à 9)

(las demás piezas como en los registros 3 al 9)

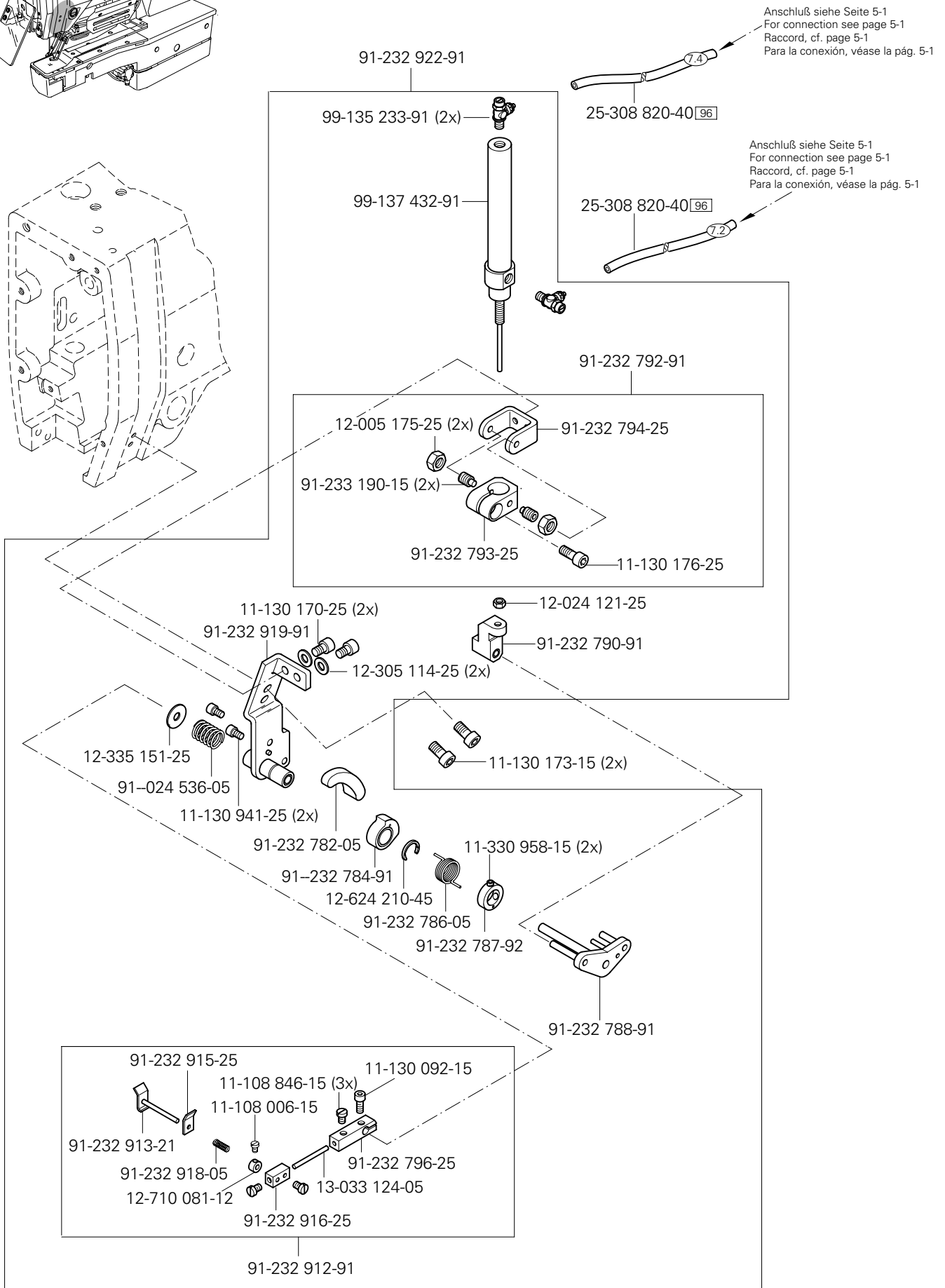
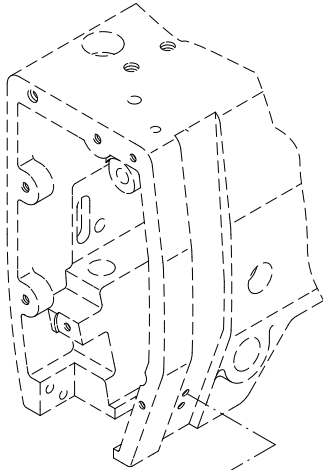
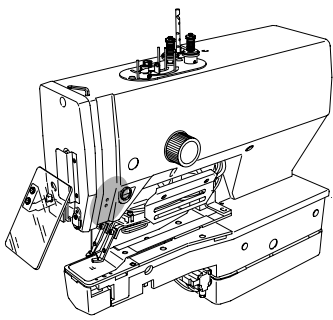

10

Abweichende Teile der PFAFF 3307-1/11
 Different parts for PFAFF 3307-1/11
 Pièces divergentes de la PFAFF 3307-1/11
 Piezas de la PFAFF 3307-1/11 que son diferentes

(die sonstigen Teile wie in Register 3 bis 9)
 (for all other parts see Sections 3 to 9)
 (les autres pièces comme dans les registres 3 à 9)
 (las demás piezas como en los registros 3 al 9)

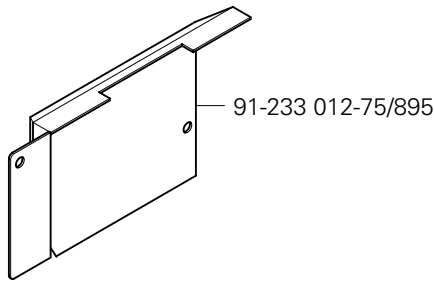
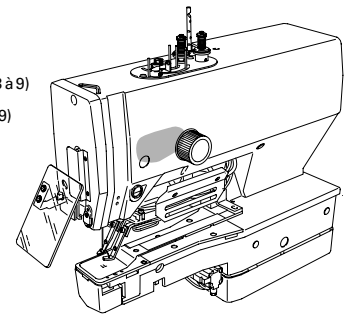

siehe Seite 3-7
 see page 3-7
 voir page 3-7
 véase la página 3-7

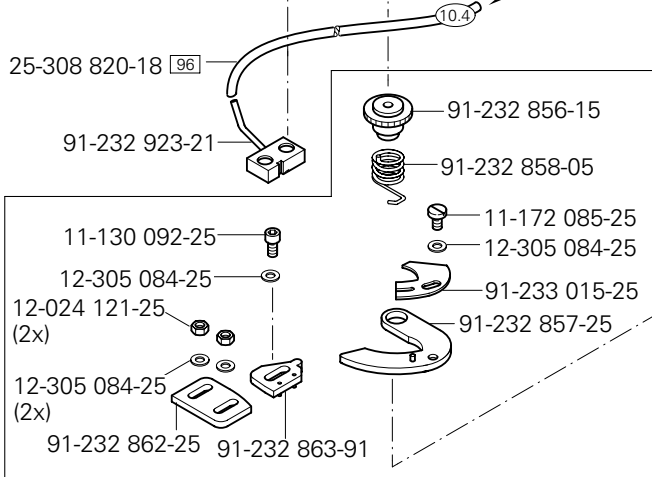
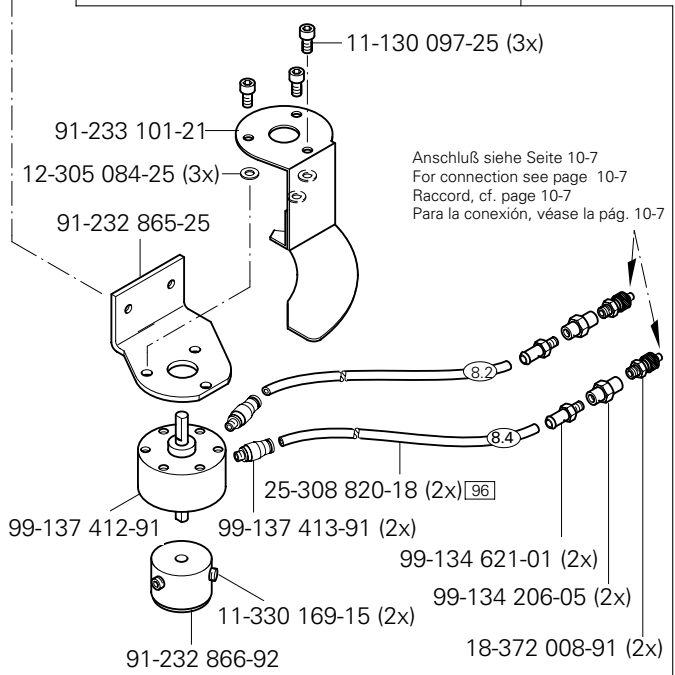
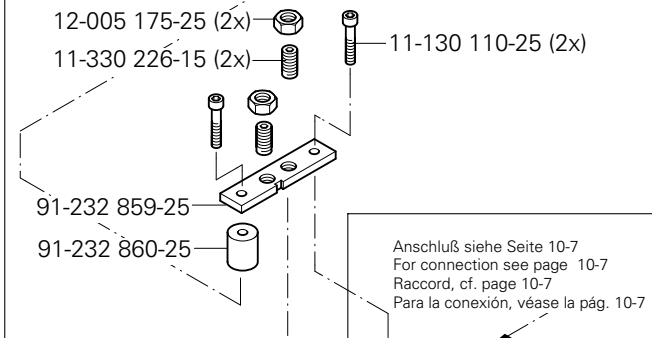
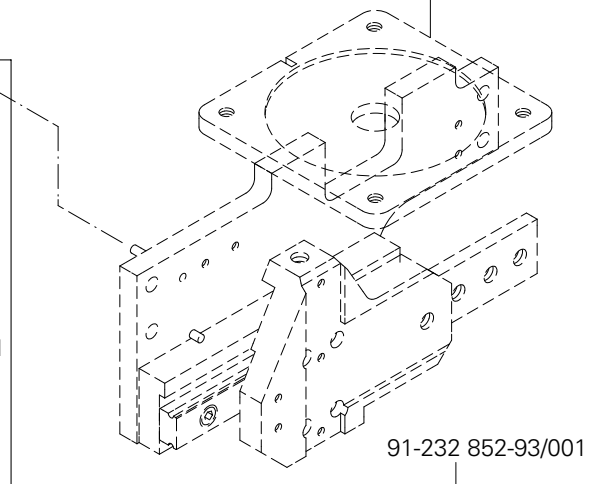
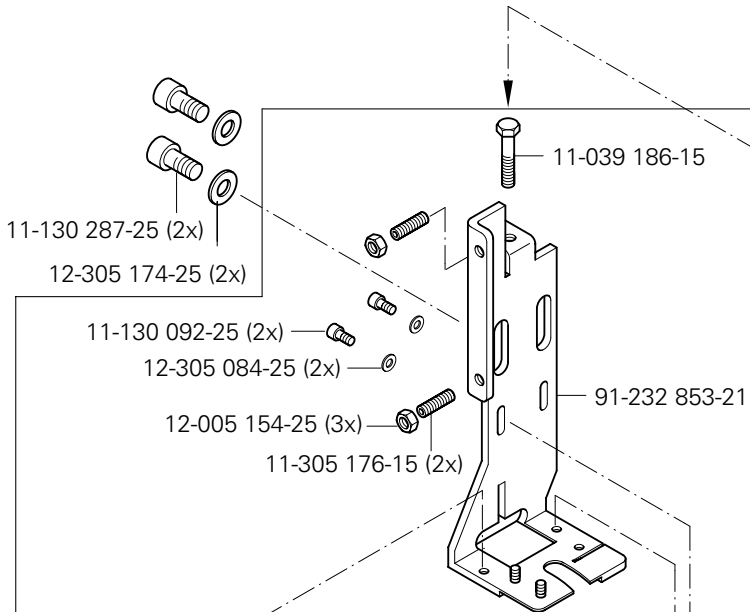

Abweichende Teile der PFAFF 3307-1/11
Different parts for PFAFF 3307-1/11
Pièces divergentes de la PFAFF 3307-1/11
Piezas de la PFAFF 3307-1/11 que son diferentes

(die sonstigen Teile wie in Register 3 bis 9)

(for all other parts see Sections 3 to 9)

(les autres pièces comme dans les registres 3 à 9)

(las demás piezas como en los registros 3 al 9)

10

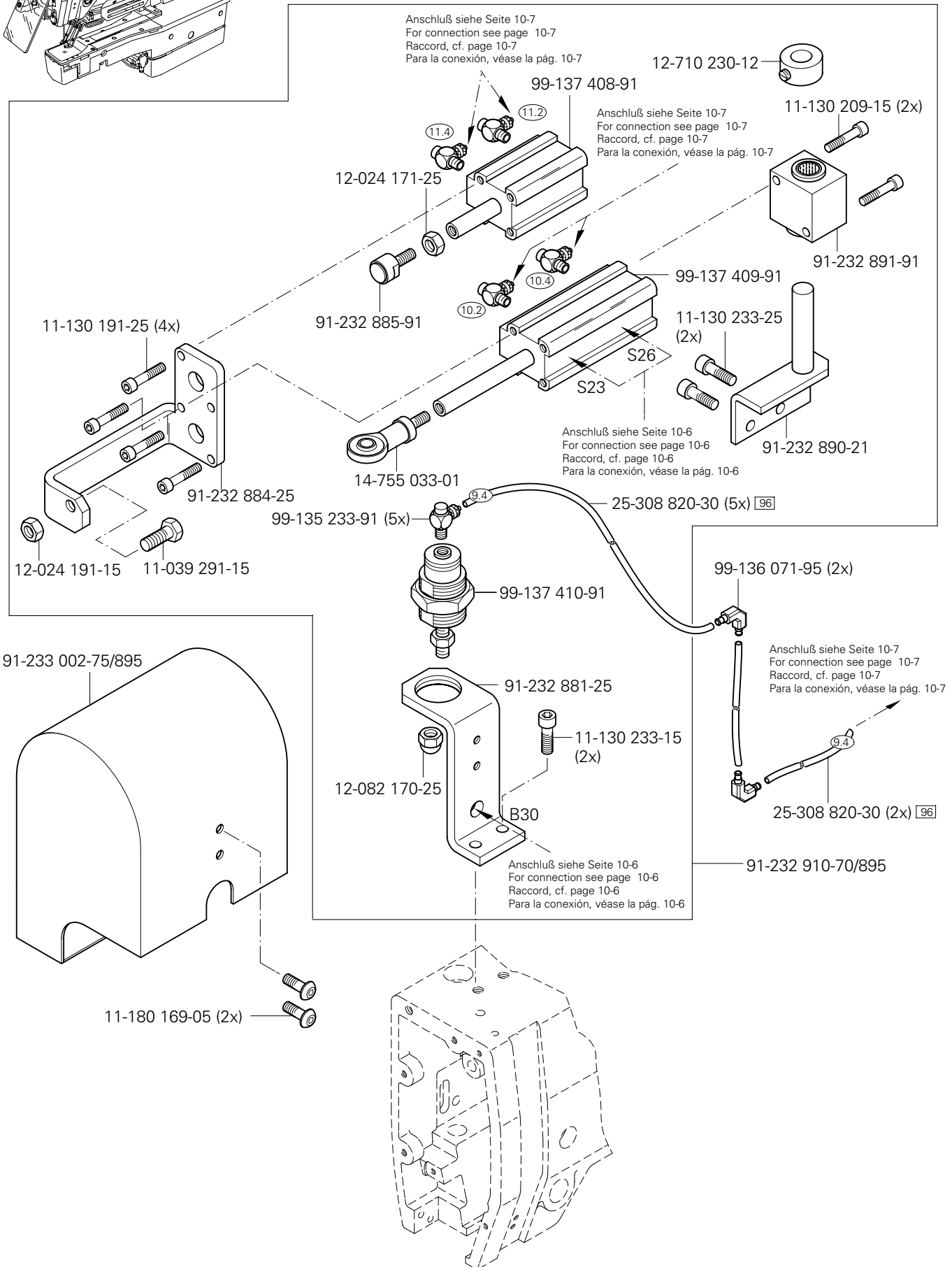
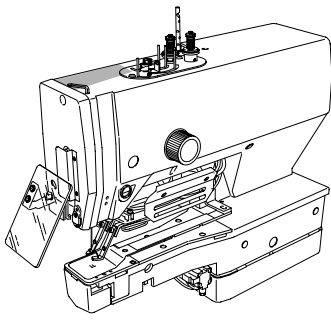

10

Abweichende Teile der PFAFF 3307-1/11

Different parts for PFAFF 3307-1/11

Pièces divergentes de la PFAFF 3307-1/11

Piezas de la PFAFF 3307-1/11 que son diferentes

(die sonstigen Teile wie in Register 3 bis 9)

(for all other parts see Sections 3 to 9)

(les autres pièces comme dans les registres 3 à 9)

(las demás piezas como en los registros 3 al 9)

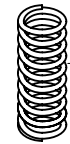
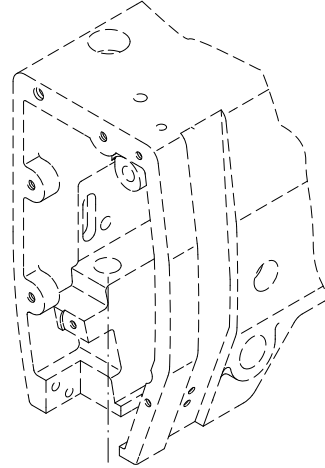
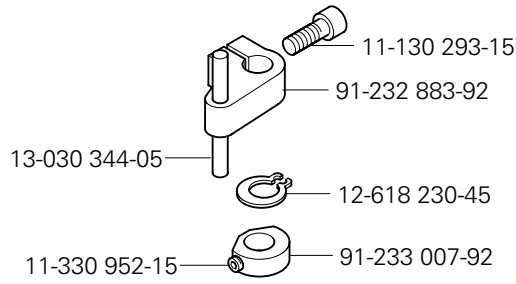
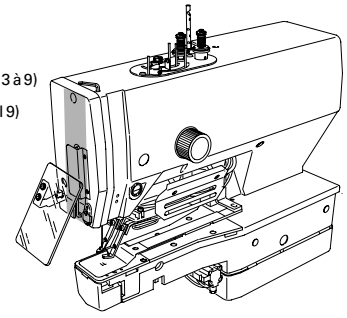

91-188 456-05

91-232 901-12 (2x)



11-330 964-15 (2x)

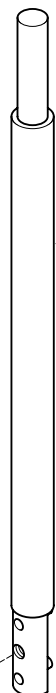

91-233 013-01

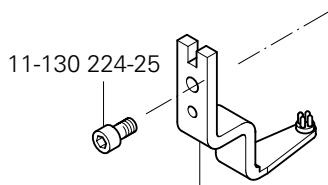

Abweichende Teile der PFAFF 3307-1/11
Different parts for PFAFF 3307-1/11
Pièces divergentes de la PFAFF 3307-1/11
Piezas de la PFAFF 3307-1/11 que son diferentes

(die sonstigen Teile wie in Register 3 bis 9)

(for all other parts see Sections 3 to 9)

(les autres pièces comme dans les registres 3 à 9)

(las demás piezas como en los registros 3 al 9)

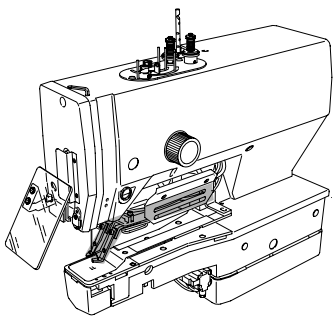

- 11-039 179-15 (3x)
- 91-164 296-15 (3x)

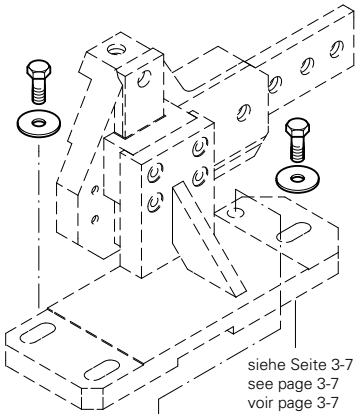

siehe Seite 3-7
 see page 3-7
 voir page 3-7
 véase la página 3-7

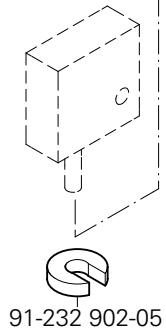

91-232 902-05

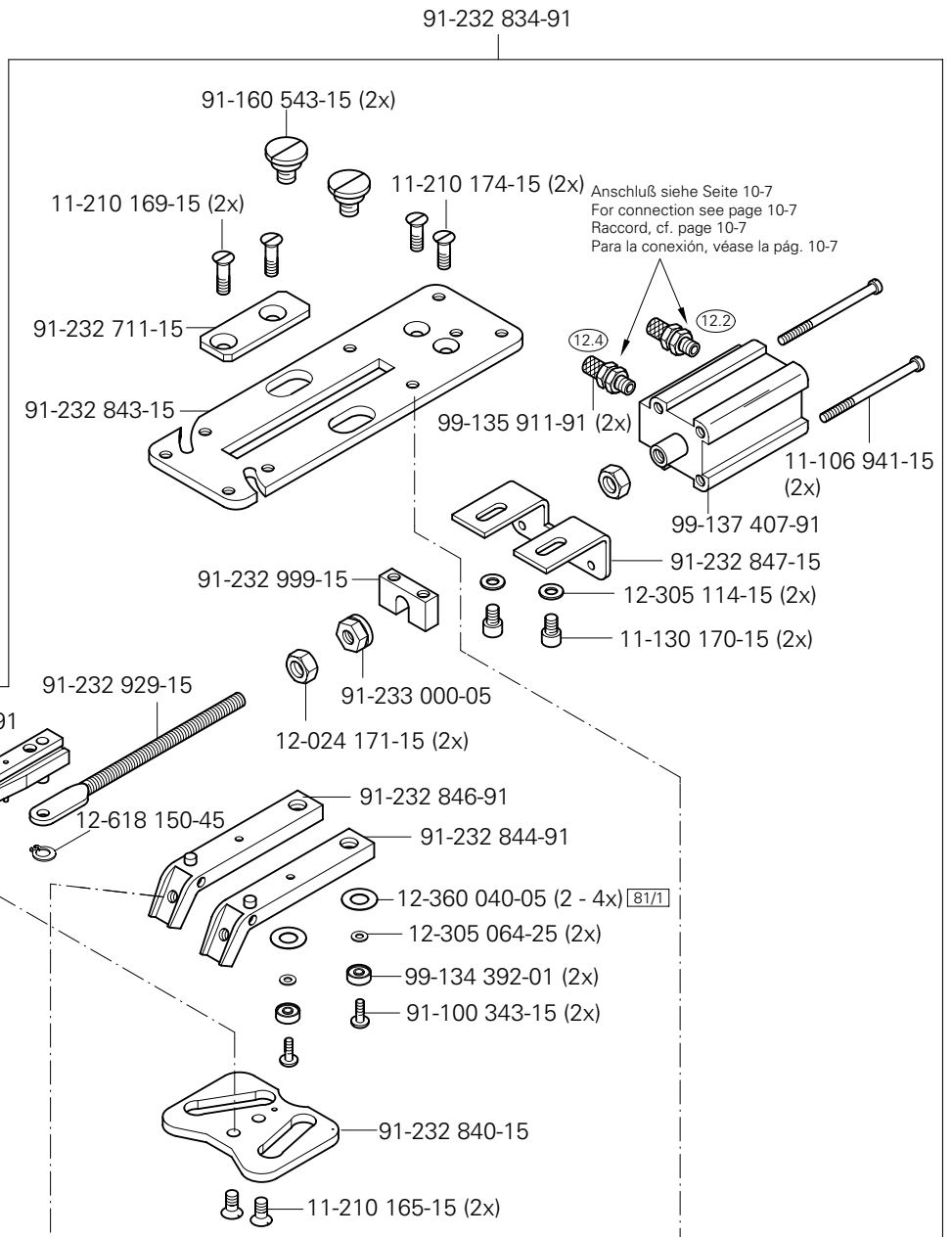

Anschluß siehe Seite 10-7
 For connection see page 10-7
 Raccord, cf. page 10-7
 Para la conexión, véase la pág. 10-7

- 11-130 173-15 (2x)
- 12-305 114-15 (2x)

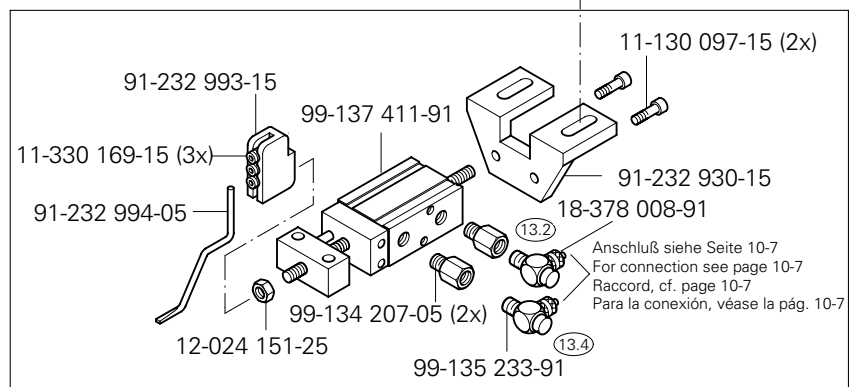
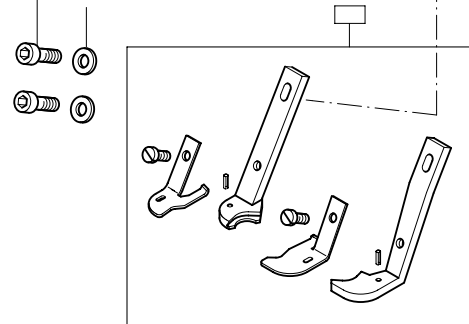

Anschluß siehe Seite 10-7
 For connection see page 10-7
 Raccord, cf. page 10-7
 Para la conexión, véase la pág. 10-7

91-232 995-91

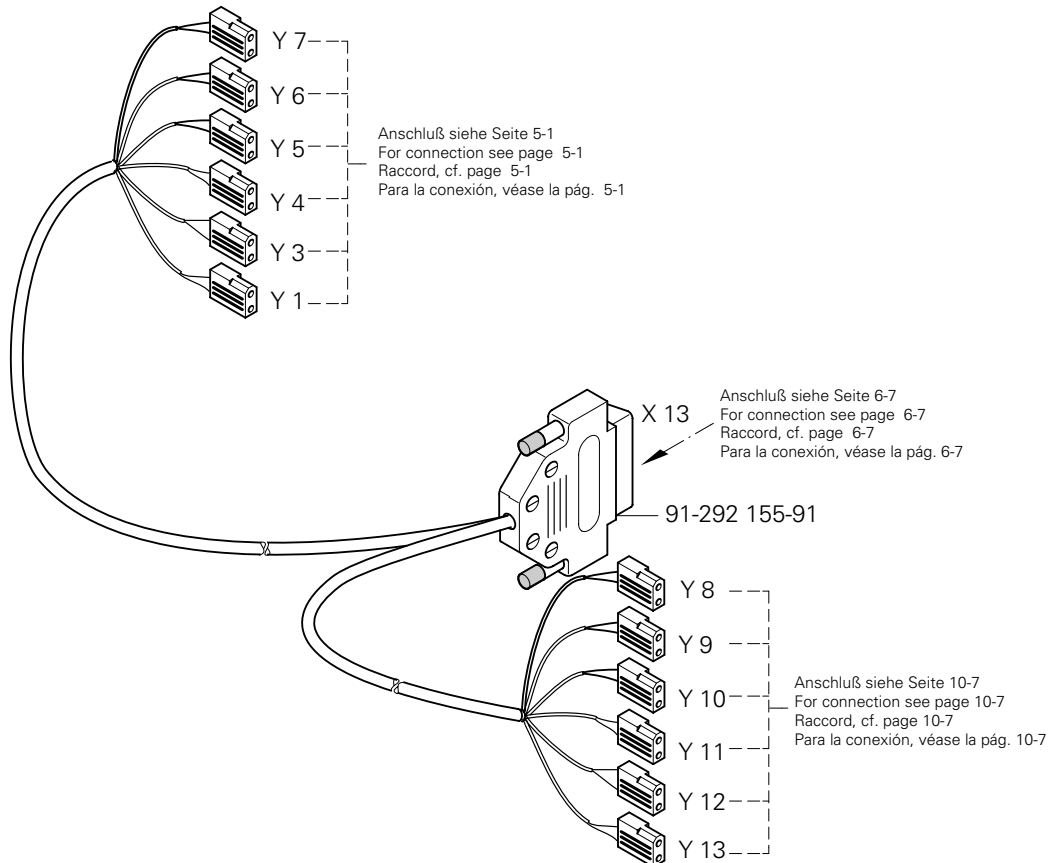
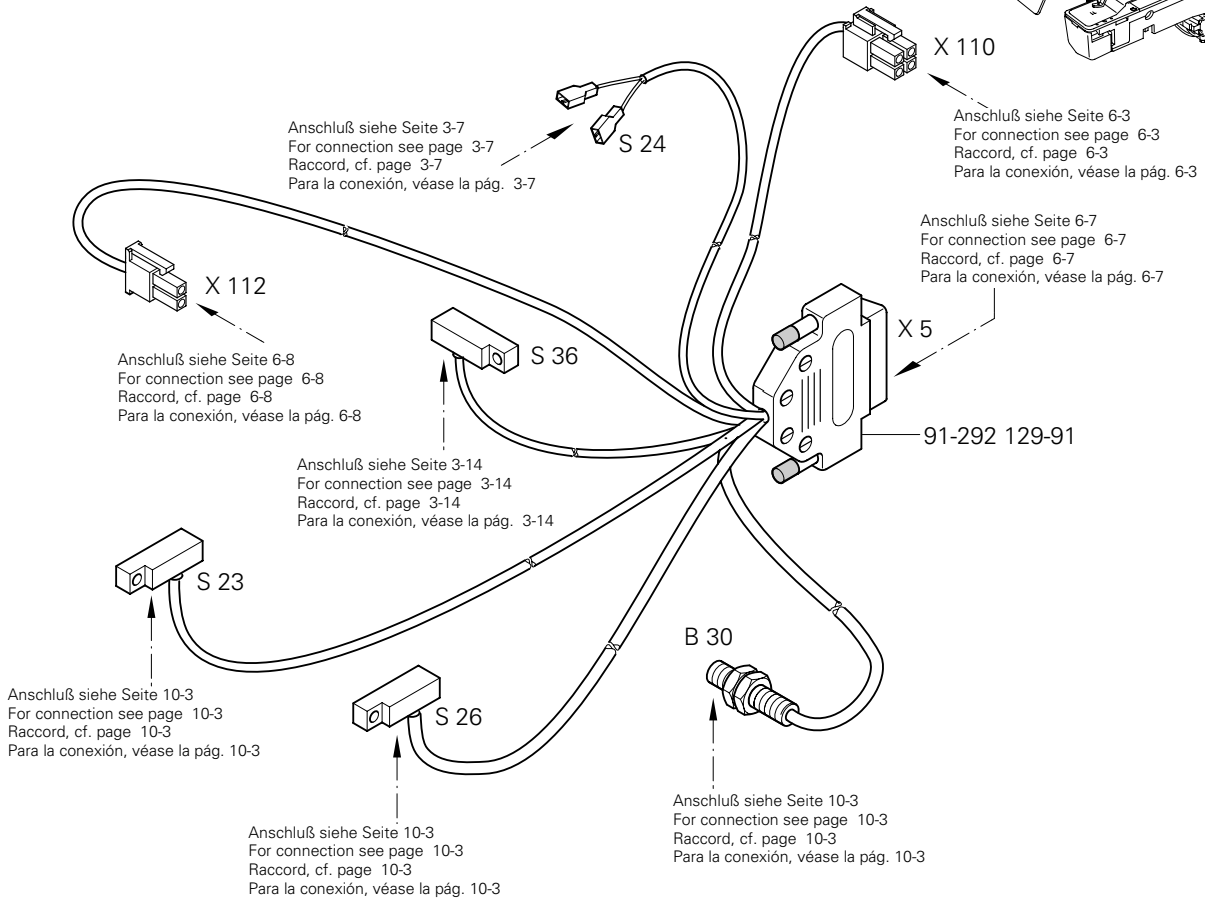
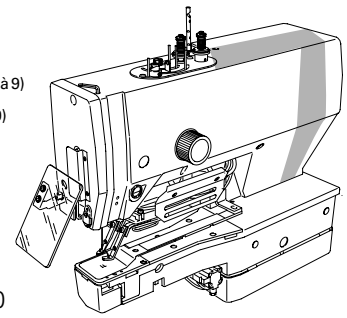

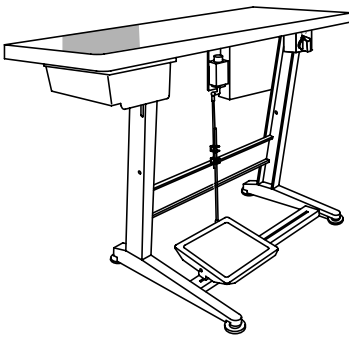

Abweichende Teile der PFAFF 3307-1/11
Different parts for PFAFF 3307-1/11
Pièces divergentes de la PFAFF 3307-1/11
Piezas de la PFAFF 3307-1/11 que son diferentes

(die sonstigen Teile wie in Register 3 bis 9)

(for all other parts see Sections 3 to 9)

(les autres pièces comme dans les registres 3 à 9)

(las demás piezas como en los registros 3 al 9)

10

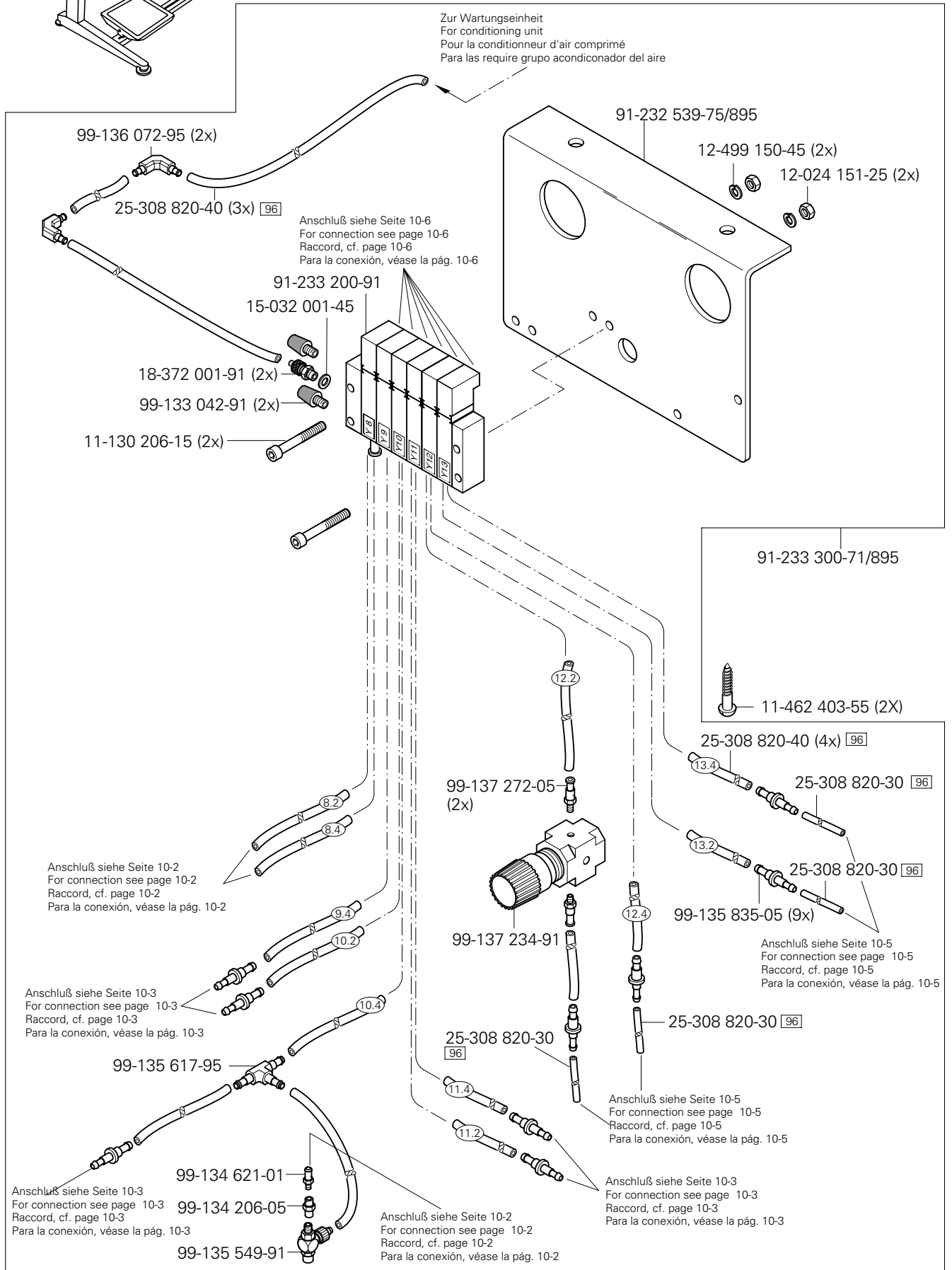

10

Abweichende Teile der PFAFF 3307-1/11

Different parts for PFAFF 3307-1/11

Pièces divergentes de la PFAFF 3307-1/11

Piezas de la PFAFF 3307-1/11 que son diferentes

(die sonstigen Teile wie in Register 3 bis 9)

(for all other parts see Sections 3 to 9)

(les autres pièces comme dans les registres 3 à 9)

(las demás piezas como en los registros 3 al 9)

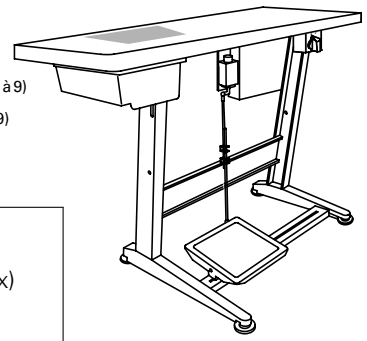

91-233 220-90

91-233 074-05 (6x)

Anschluß siehe Seite 10-9
For connection see page 10-9
Raccord, cf. page 10-9
Para la conexión, véase la pág. 10-9

91-233 079-01

91-233 083-05

91-233 078-05

91-233 077-05

91-233 087-05

91-233 090-05

91-233 075-04

91-233 085-05

99-137 425-91

91-233 088-04/001 (3,0 x 10,0) 95/8

91-233 088-04/002 (3,0 x 13,0) 95/8

91-233 088-04/003 (4,5 x 11,5) 95/8

91-233 076-05 (3x)

Anschluß siehe Seite 10-10
For connection see page 10-10
Raccord, cf. page 10-10
Para la conexión, véase la pág. 10-10

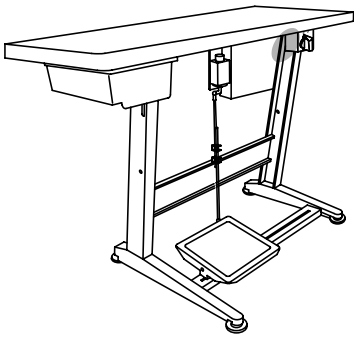

Abweichende Teile der PFAFF 3307-1/11
 Different parts for PFAFF 3307-1/11
 Pièces divergentes de la PFAFF 3307-1/11
 Piezas de la PFAFF 3307-1/11 que son diferentes

(die sonstigen Teile wie in Register 3 bis 9)
 (for all other parts see Sections 3 to 9)
 (les autres pièces comme dans les registres 3 à 9)
 (las demás piezas como en los registros 3 al 9)

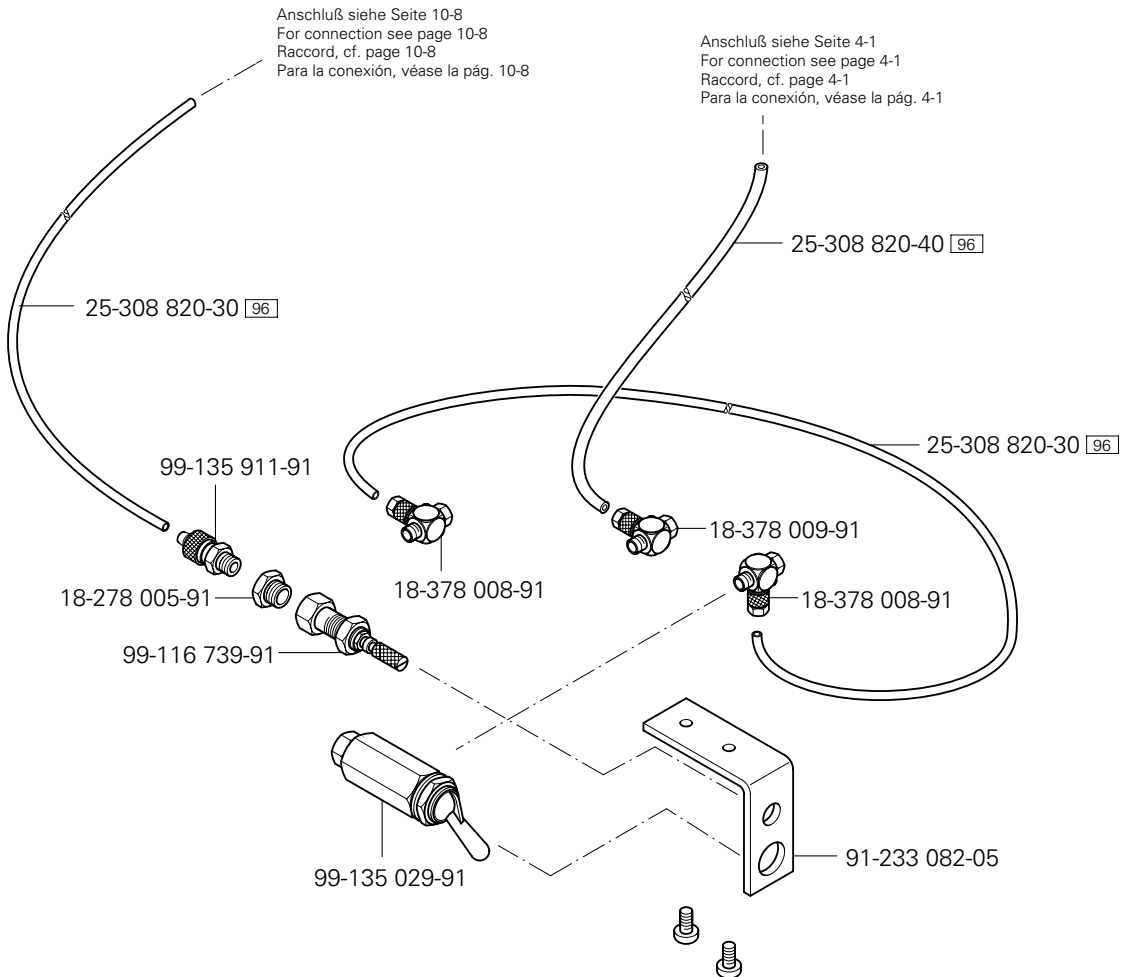

10

Abweichende Teile der PFAFF 3307-1/11

Different parts for PFAFF 3307-1/11

Pièces divergentes de la PFAFF 3307-1/11

Piezas de la PFAFF 3307-1/11 que son diferentes

(die sonstigen Teile wie in Register 3 bis 9)

(for all other parts see Sections 3 to 9)

(les autres pièces comme dans les registres 3 à 9)

(las demás piezas como en los registros 3 al 9)

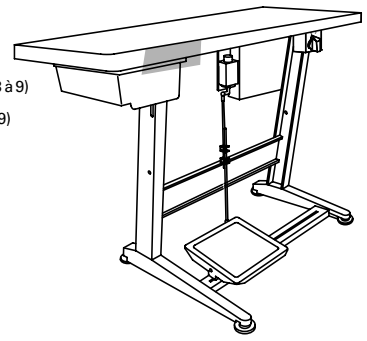

91-292 140-91

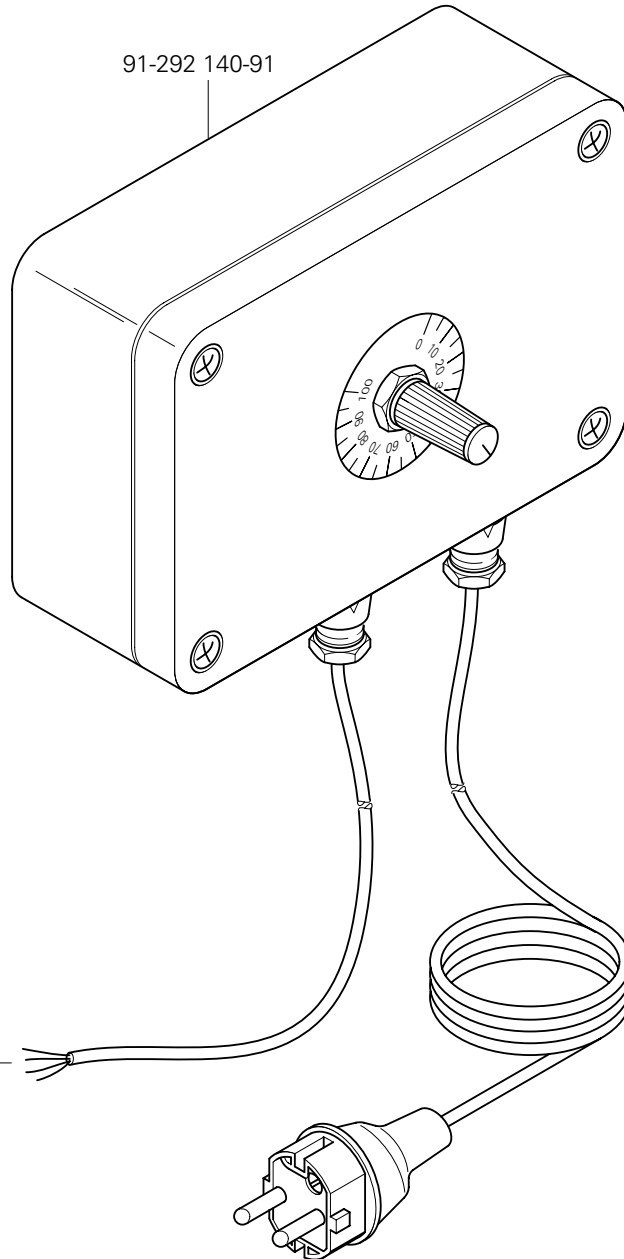

Anschluß siehe Seite 10-8
For connection see page 10-8
Raccord, cf. page 10-8
Para la conexión, véase la pág. 10-8

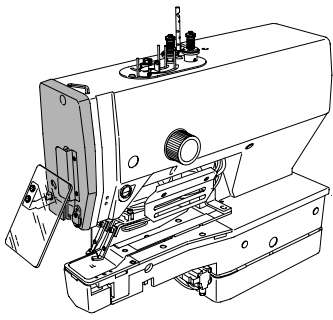

Abweichende Teile der PFAFF 3307-3/01
 Different parts for PFAFF 3307-3/01
 Pièces divergentes de la PFAFF 3307-3/01
 Piezas de la PFAFF 3307-3/01 que son diferentes

(die sonstigen Teile wie in Register 3 bis 9)
 (for all other parts see Sections 3 to 9)
 (les autres pièces comme dans les registres 3 à 9)
 (las demás piezas como en los registros 3 al 9)

91-232 347-71/893

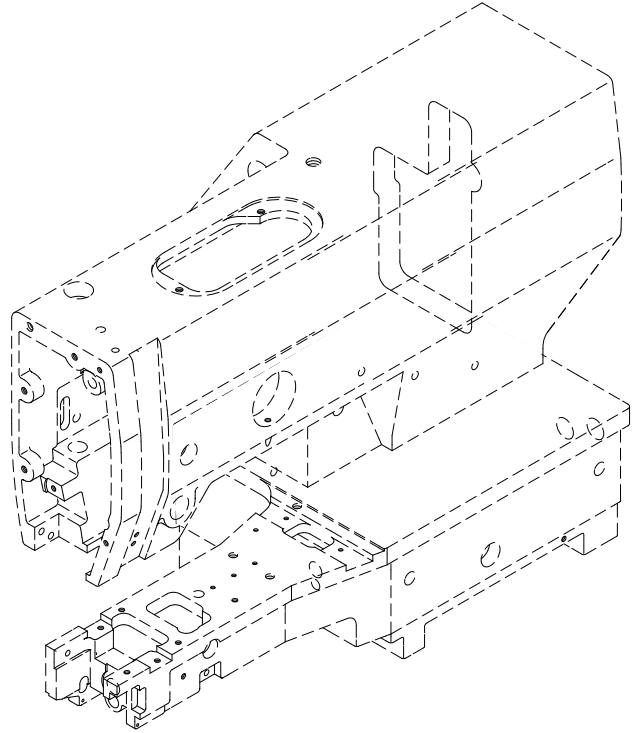
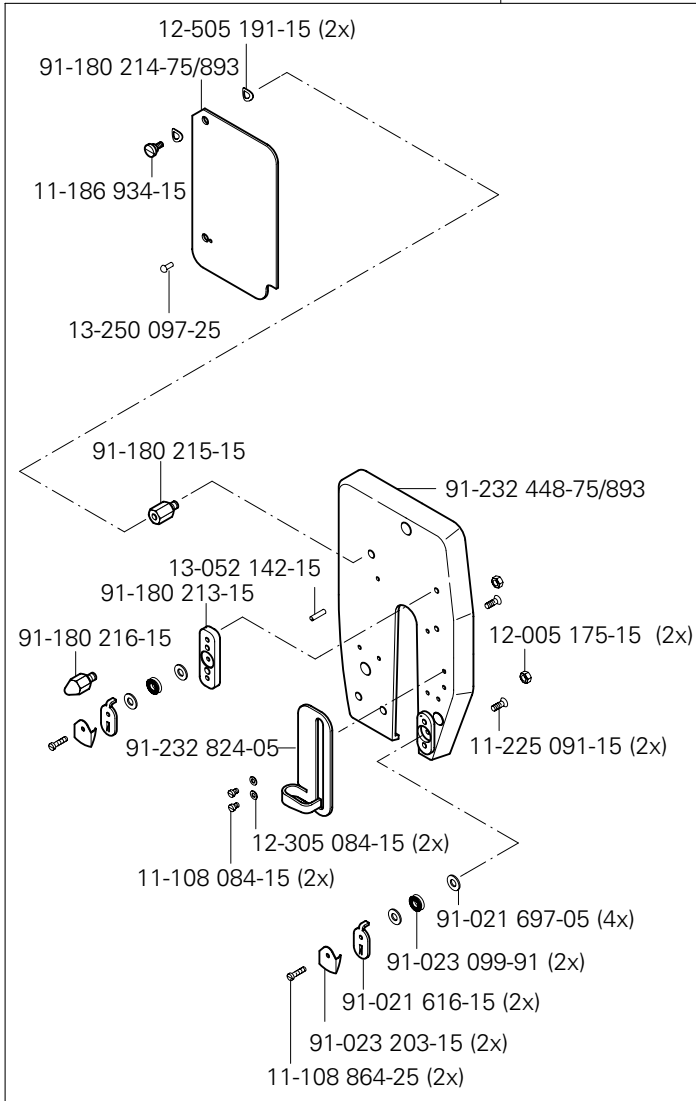

91-180 319-91

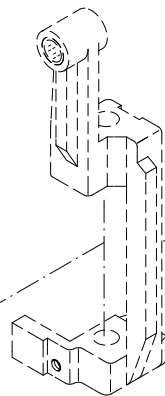
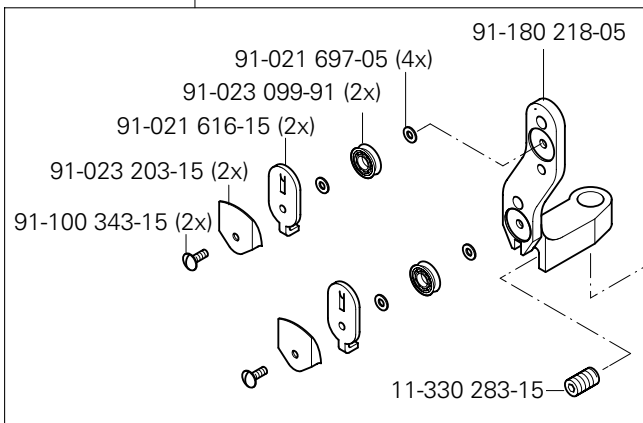

siehe Seite 3-2
 see page 3-2
 voir page 3-2
 véase la página 3-2

Abweichende Teile der PFAFF 3307-3/01

Different parts for PFAFF 3307-3/01

Pièces divergentes de la PFAFF 3307-3/01

Piezas de la PFAFF 3307-3/01 que son diferentes

(die sonstigen Teile wie in Register 3 bis 9)

(for all other parts see Sections 3 to 9)

(les autres pièces comme dans les registres 3 à 9)

(las demás piezas como en los registros 3 al 9)

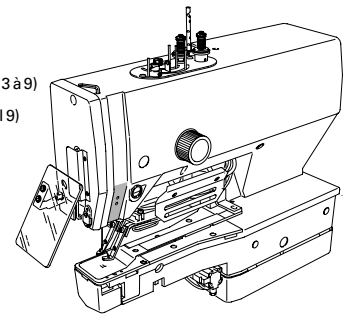

Anschluß siehe Seite 5-1
For connection see page 5-1
Raccord, cf. page 5-1
Para la conexión, véase la pág. 5-1

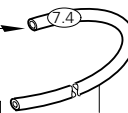

25-308 820-30 [96]

Anschluß siehe Seite 5-1
For connection see page 5-1
Raccord, cf. page 5-1
Para la conexión, véase la pág. 5-1

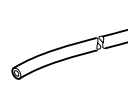

25-308 820-30 [96]

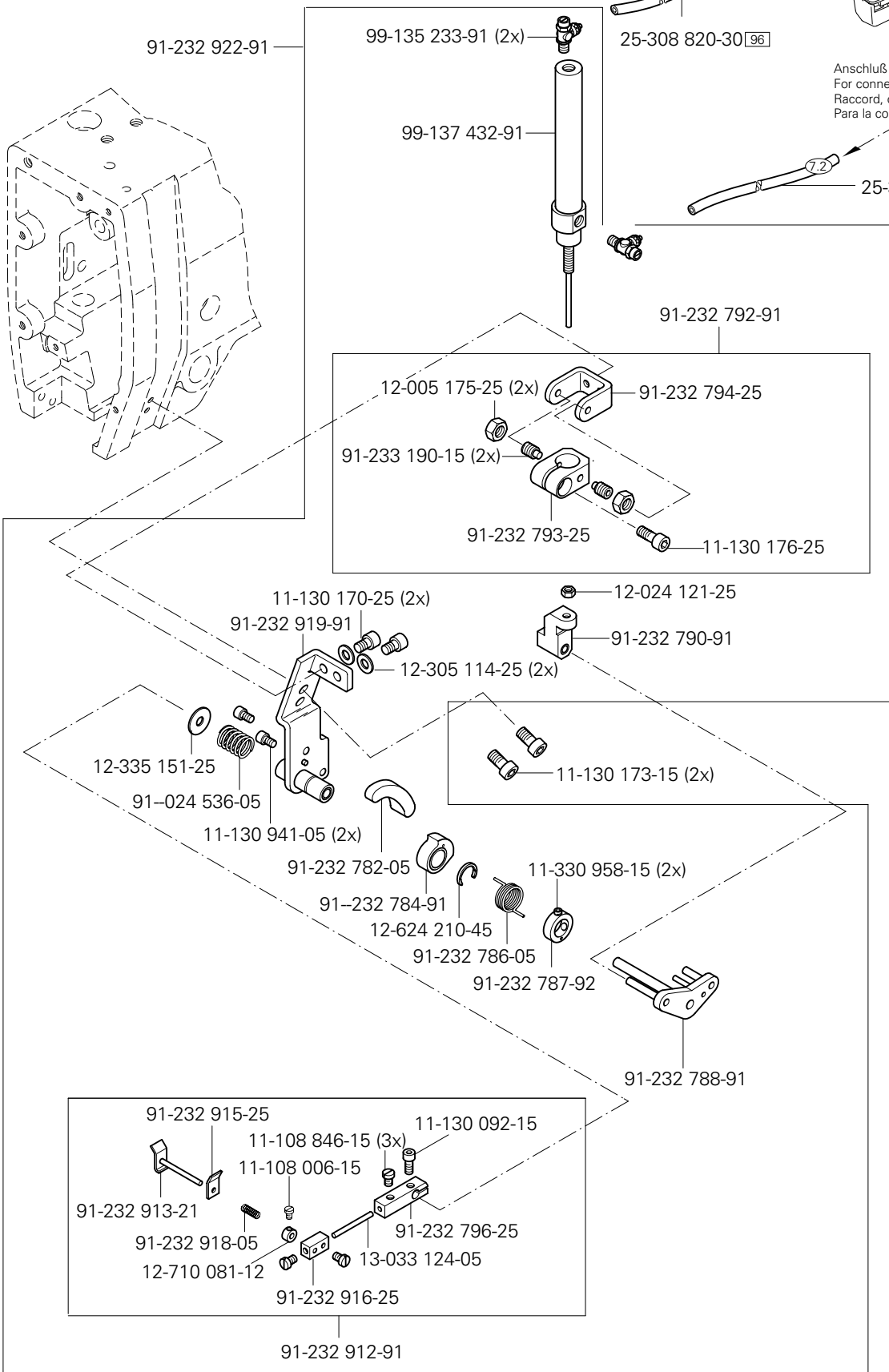

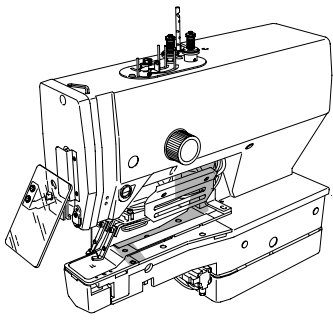

Abweichende Teile der PFAFF 3307-3/01
 Different parts for PFAFF 3307-3/01
 Pièces divergentes de la PFAFF 3307-3/01
 Piezas de la PFAFF 3307-3/01 que son diferentes

(die sonstigen Teile wie in Register 3 bis 9)

(for all other parts see Sections 3 to 9)

(les autres pièces comme dans les registres 3 à 9)

(las demás piezas como en los registros 3 al 9)

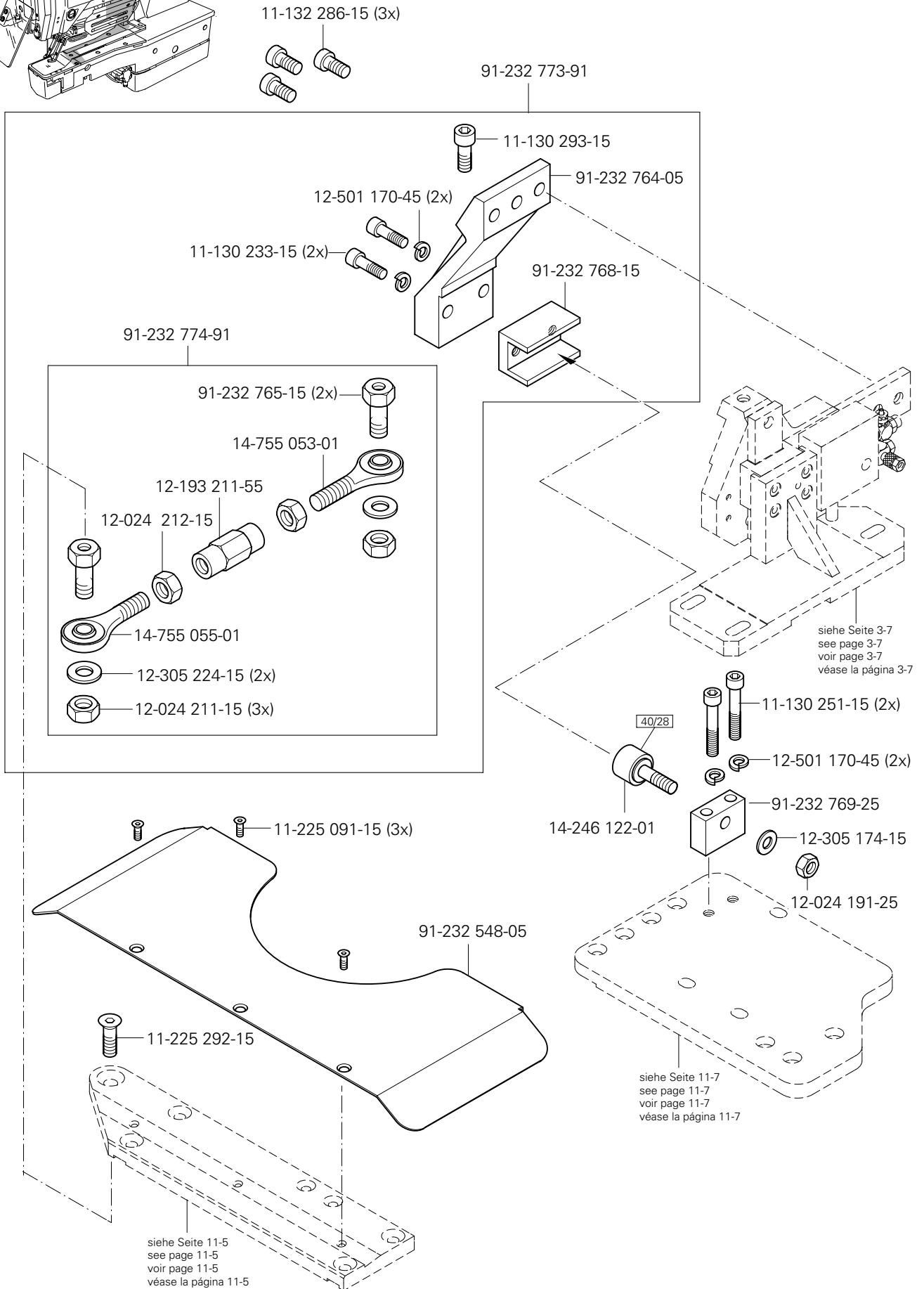

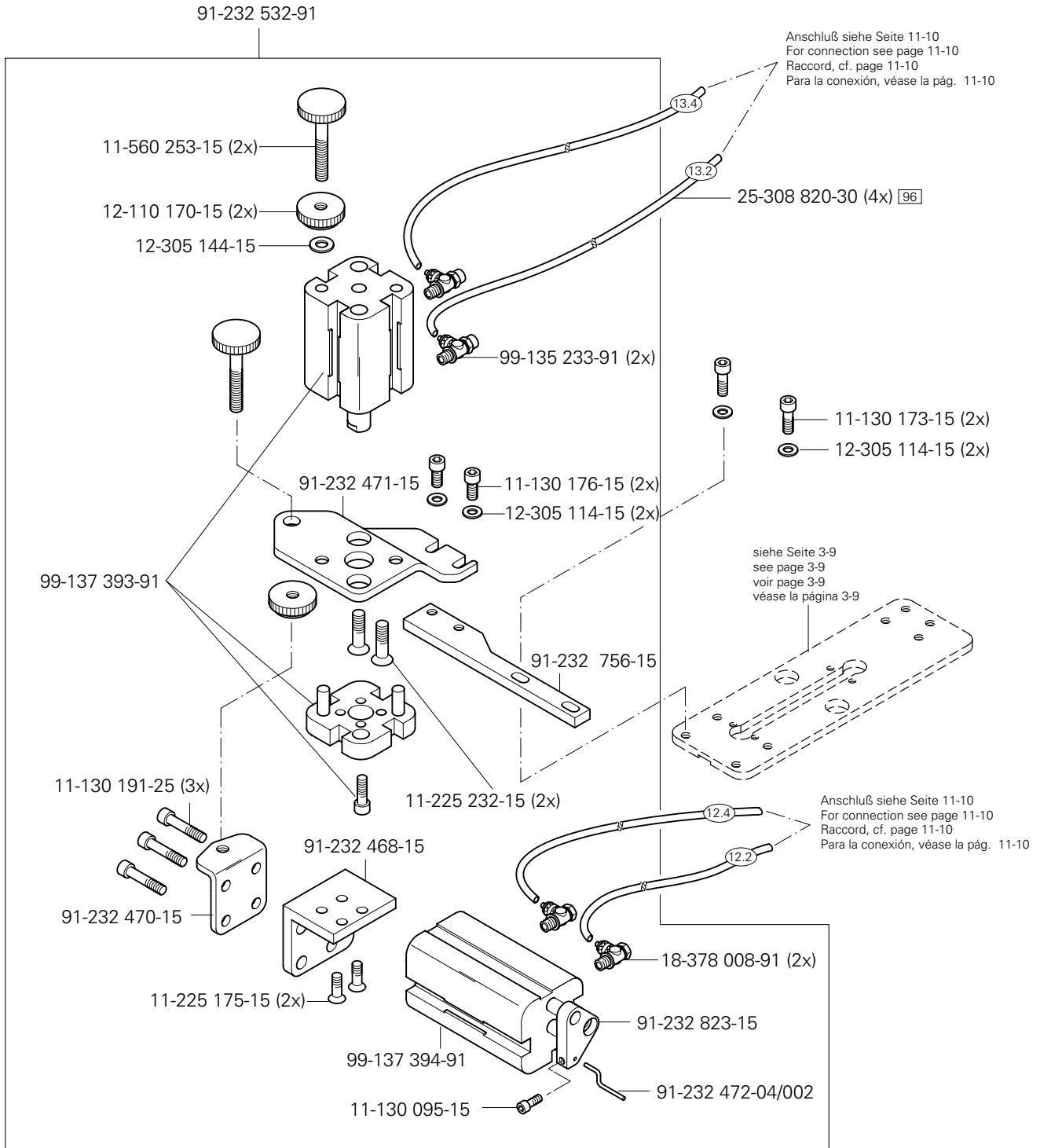
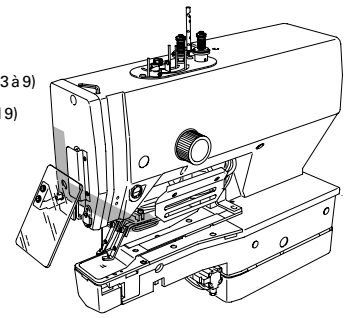

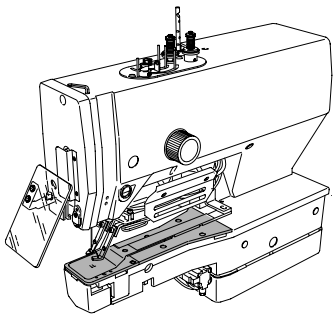

Abweichende Teile der PFAFF 3307-3/01
Different parts for PFAFF 3307-3/01
Pièces divergentes de la PFAFF 3307-3/01
Piezas de la PFAFF 3307-3/01 que son diferentes

(die sonstigen Teile wie in Register 3 bis 9)

(for all other parts see Sections 3 to 9)

(les autres pièces comme dans les registres 3 à 9)

(las demás piezas como en los registros 3 al 9)

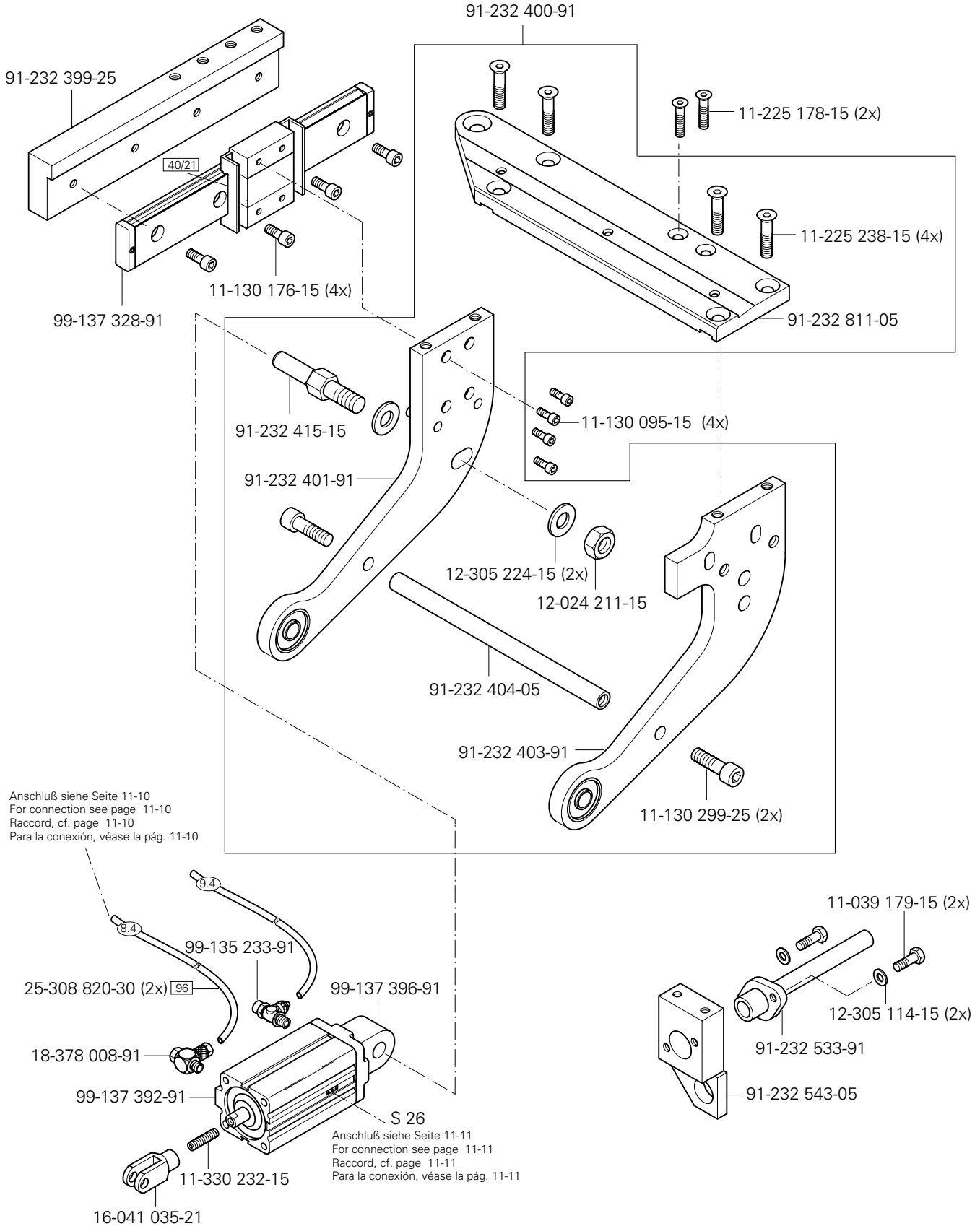

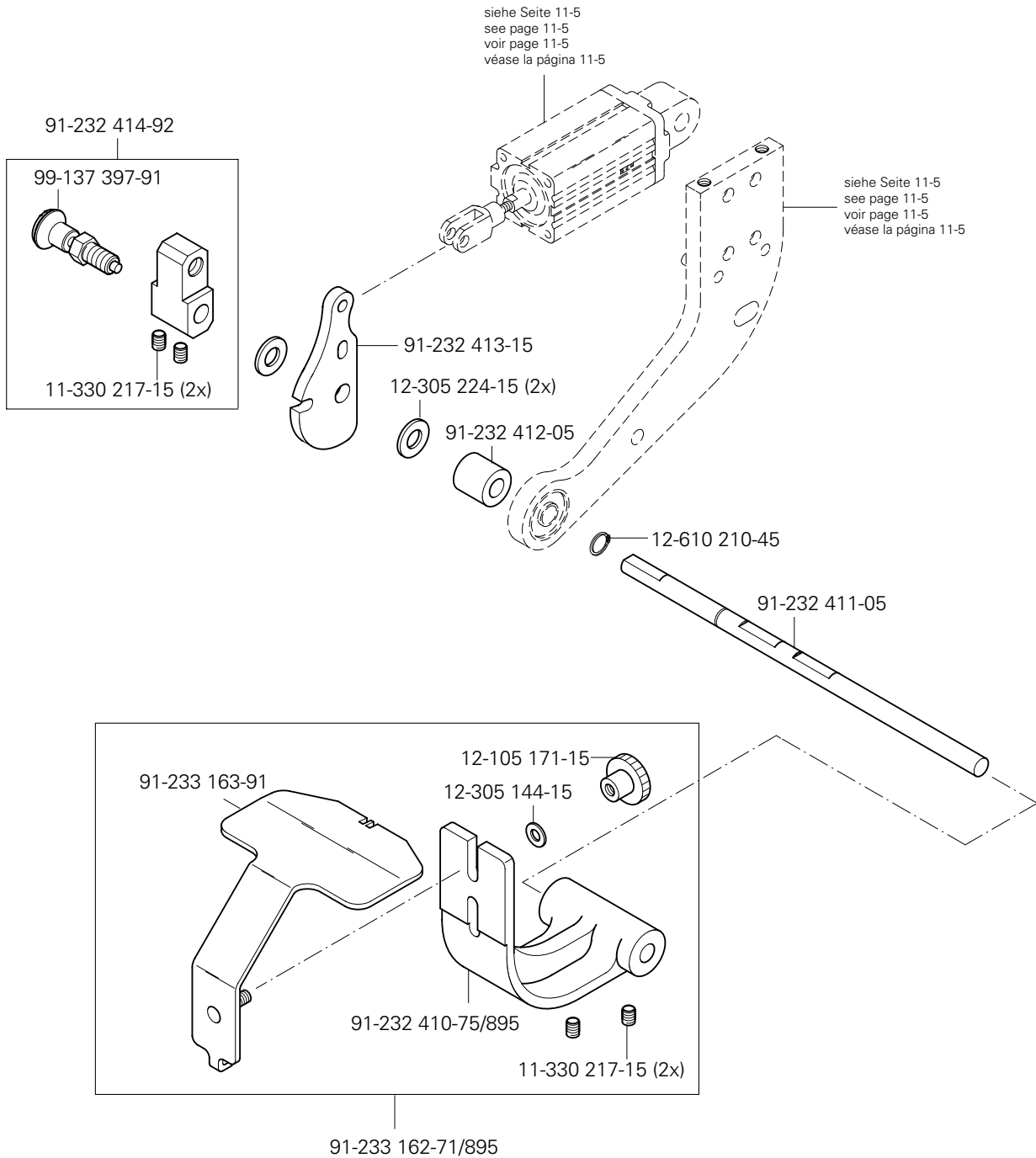
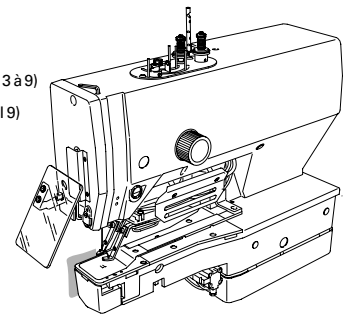

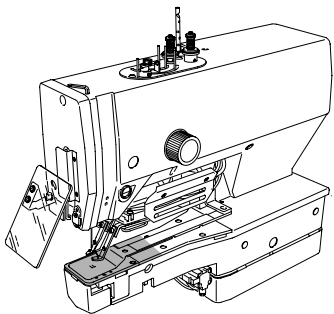

Abweichende Teile der PFAFF 3307-3/01
Different parts for PFAFF 3307-3/01
Pièces divergentes de la PFAFF 3307-3/01
Piezas de la PFAFF 3307-3/01 que son diferentes

(die sonstigen Teile wie in Register 3 bis 9)

(for all other parts see Sections 3 to 9)

(les autres pièces comme dans les registres 3 à 9)

(las demás piezas como en los registros 3 al 9)

Anschluß siehe Seite 11-10
 For connection see page 11-10
 Raccord, cf. page 11-10
 Para la conexión, véase la pág. 11-10

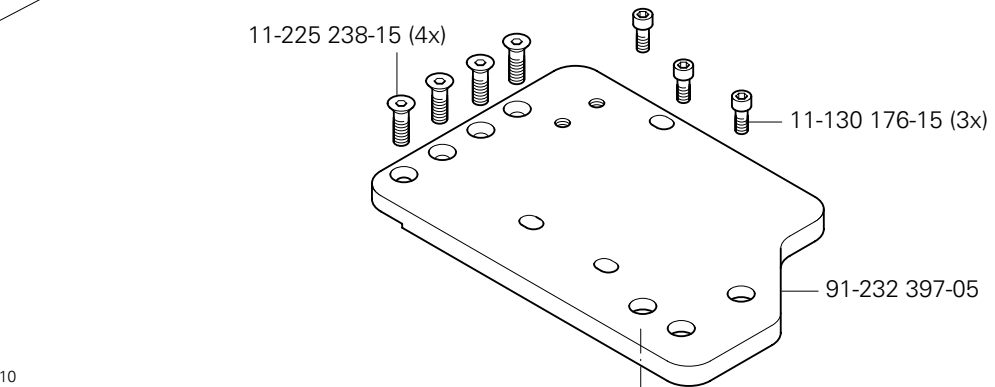

Anschluß siehe Seite 11-10
 For connection see page 11-10
 Raccord, cf. page 11-10
 Para la conexión, véase la pág. 11-10

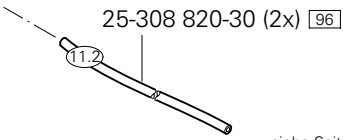

siehe Seite 11-5
 see page 11-5
 voir page 11-5
 véase la página 11-5

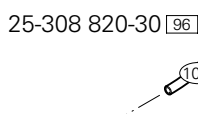
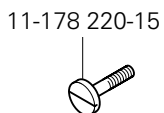
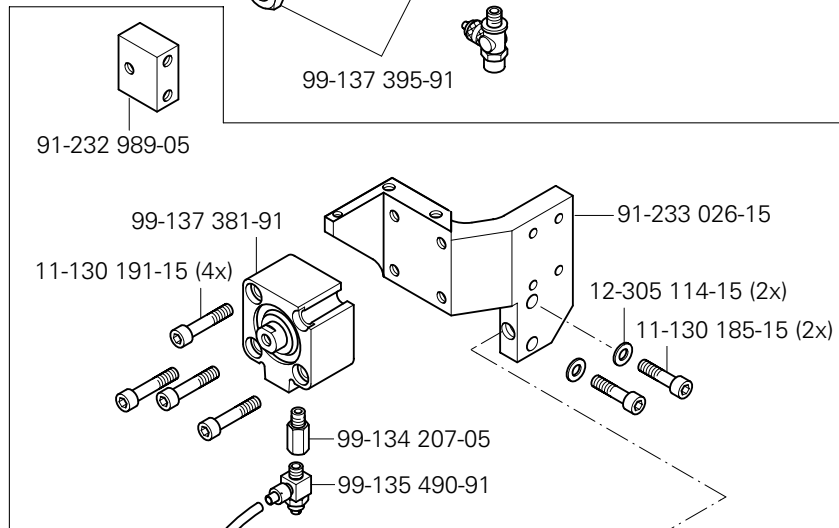
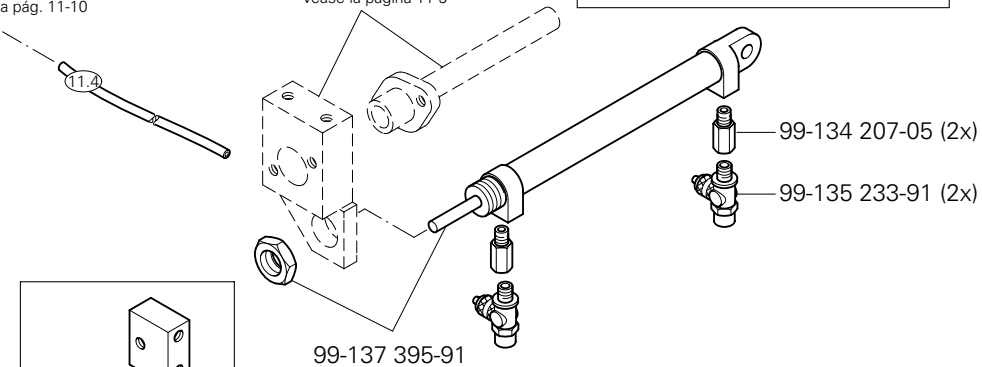
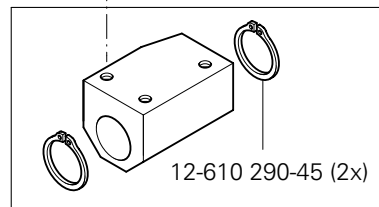

Anschluß siehe Seite 11-10
 For connection see page 11-10
 Raccord, cf. page 11-10
 Para la conexión, véase la pág. 11-10

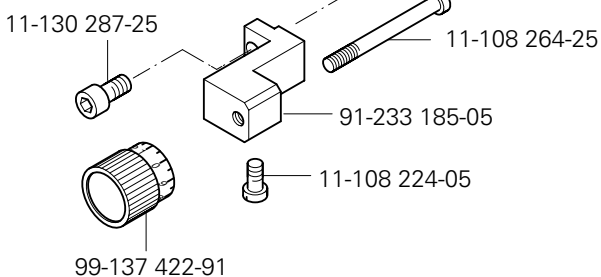

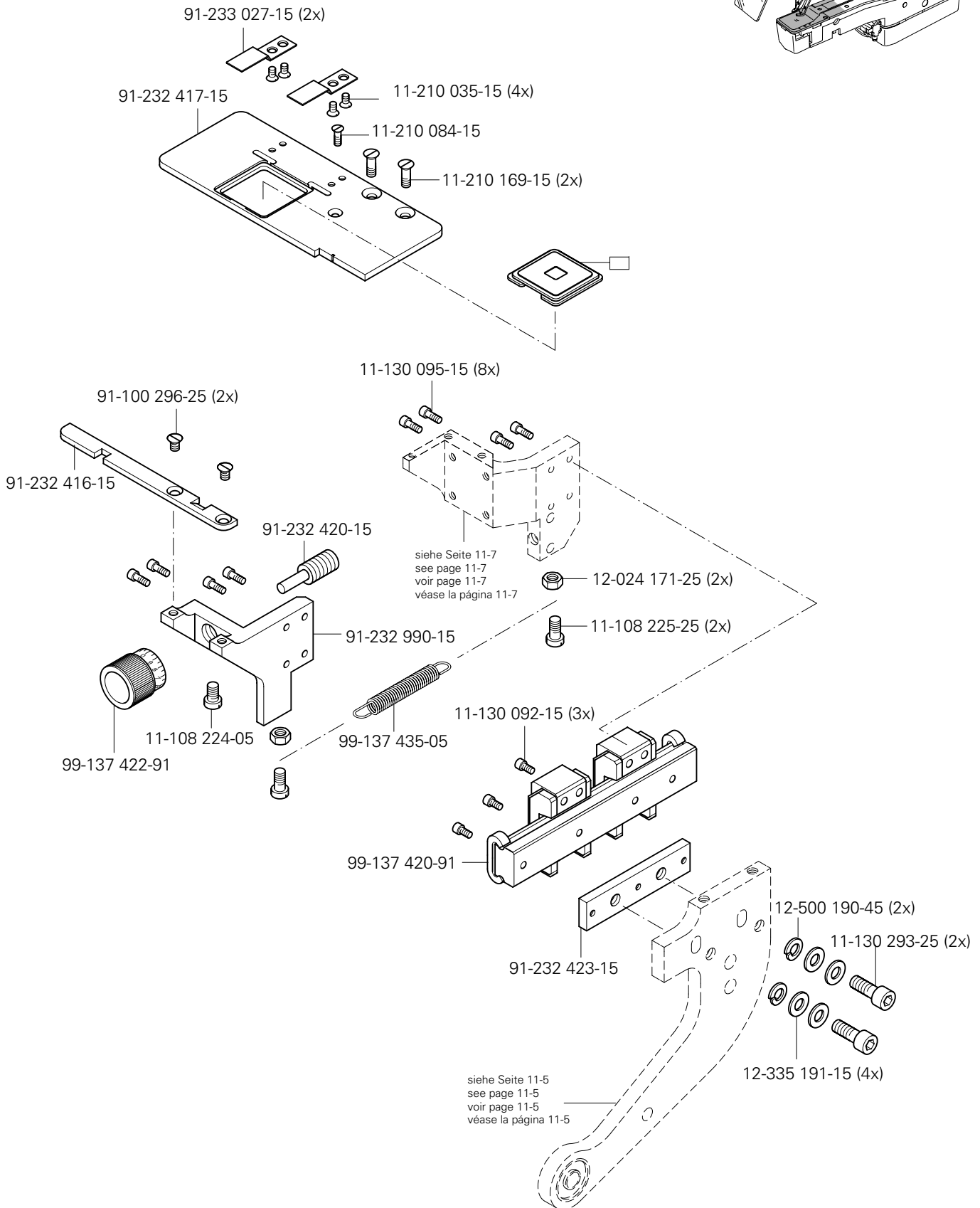
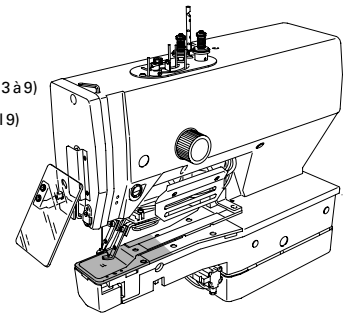

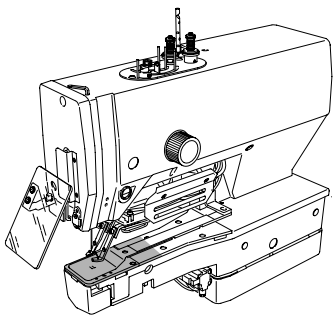

Abweichende Teile der PFAFF 3307-3/01
 Different parts for PFAFF 3307-3/01
 Pièces divergentes de la PFAFF 3307-3/01
 Piezas de la PFAFF 3307-3/01 que son diferentes

(die sonstigen Teile wie in Register 3 bis 9)
 (for all other parts see Sections 3 to 9)
 (les autres pièces comme dans les registres 3 à 9)
 (las demás piezas como en los registros 3 al 9)

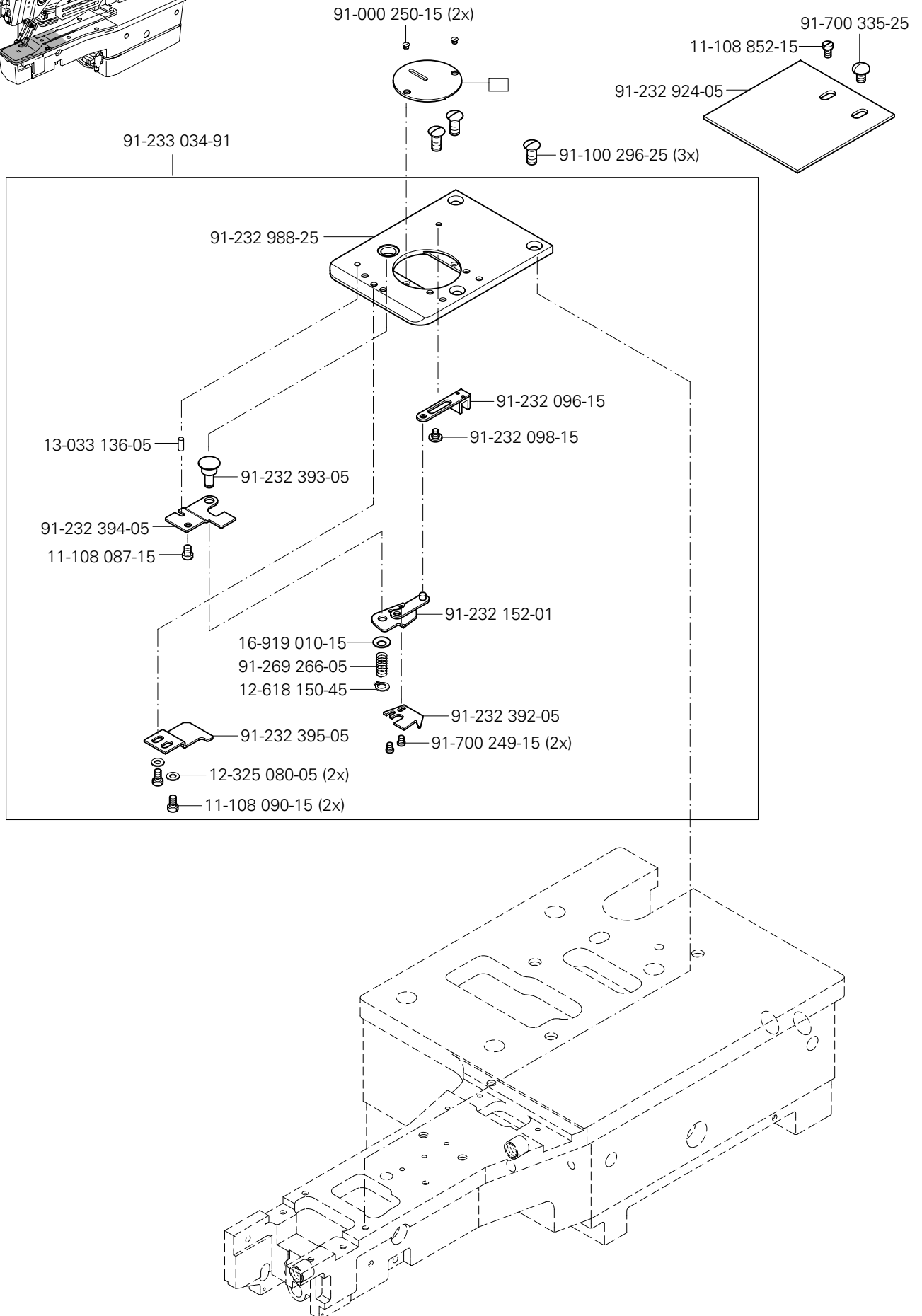

Abweichende Teile der PFAFF 3307-3/01
Different parts for PFAFF 3307-3/01
Pièces divergentes de la PFAFF 3307-3/01
Piezas de la PFAFF 3307-3/01 que son diferentes

(die sonstigen Teile wie in Register 3 bis 9)
 (for all other parts see Sections 3 to 9)
 (les autres pièces comme dans les registres 3 à 9)
 (las demás piezas como en los registros 3 a 9)

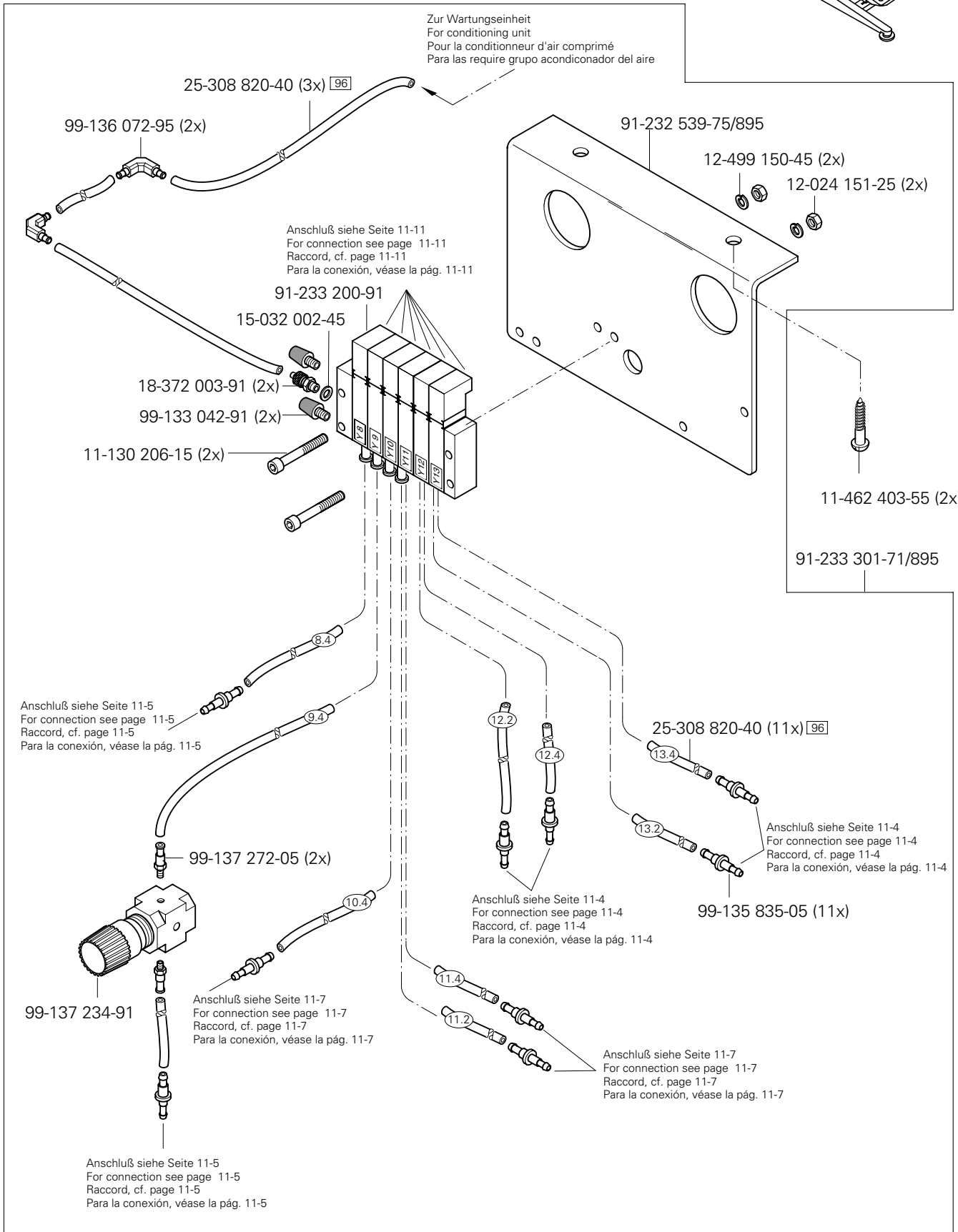
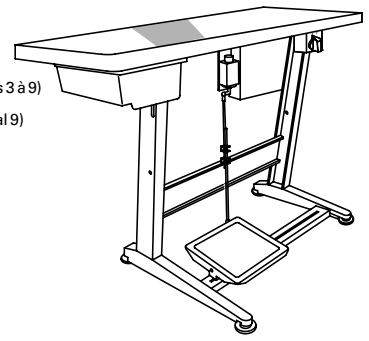

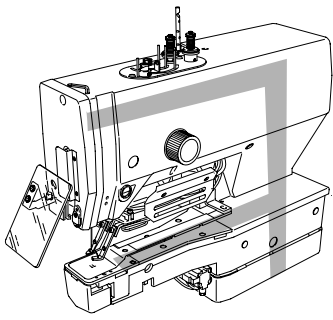

Abweichende Teile der PFAFF 3307-3/01
Different parts for PFAFF 3307-3/01
Pièces divergentes de la PFAFF 3307-3/01
Piezas de la PFAFF 3307-3/01 que son diferentes

(die sonstigen Teile wie in Register 3 bis 9)

(for all other parts see Sections 3 to 9)

(les autres pièces comme dans les registres 3 à 9)

(las demás piezas como en los registros 3 al 9)

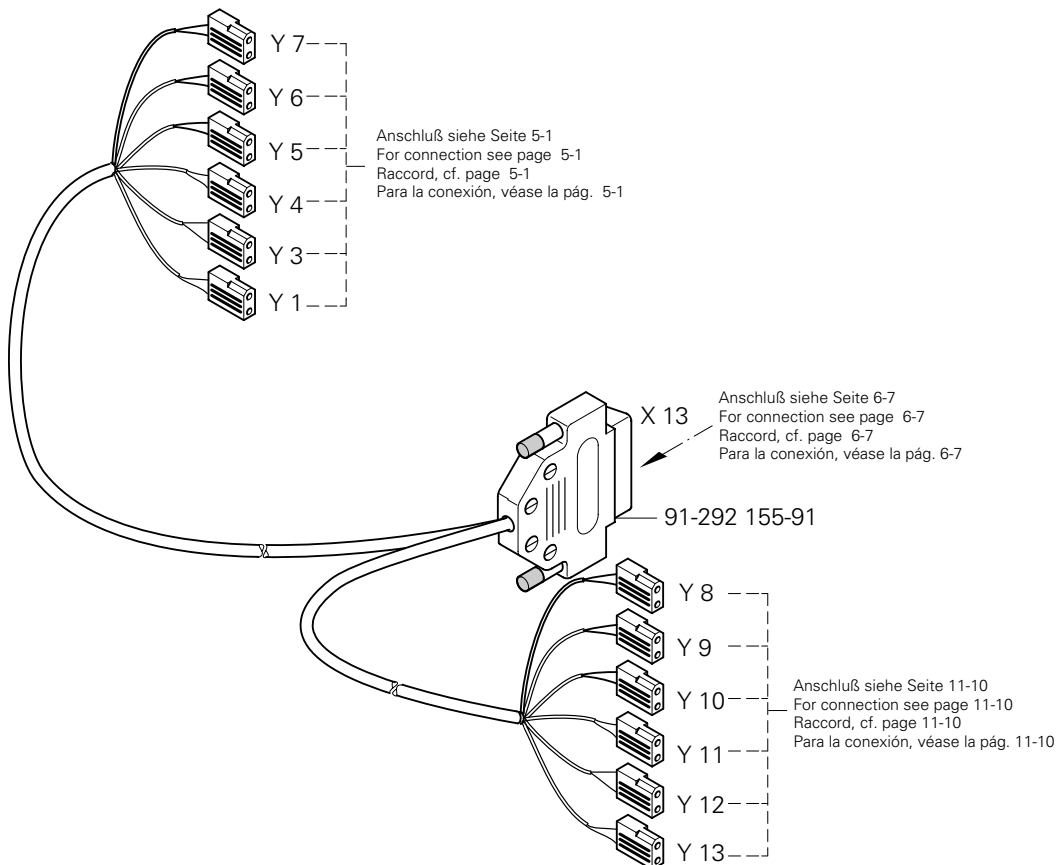
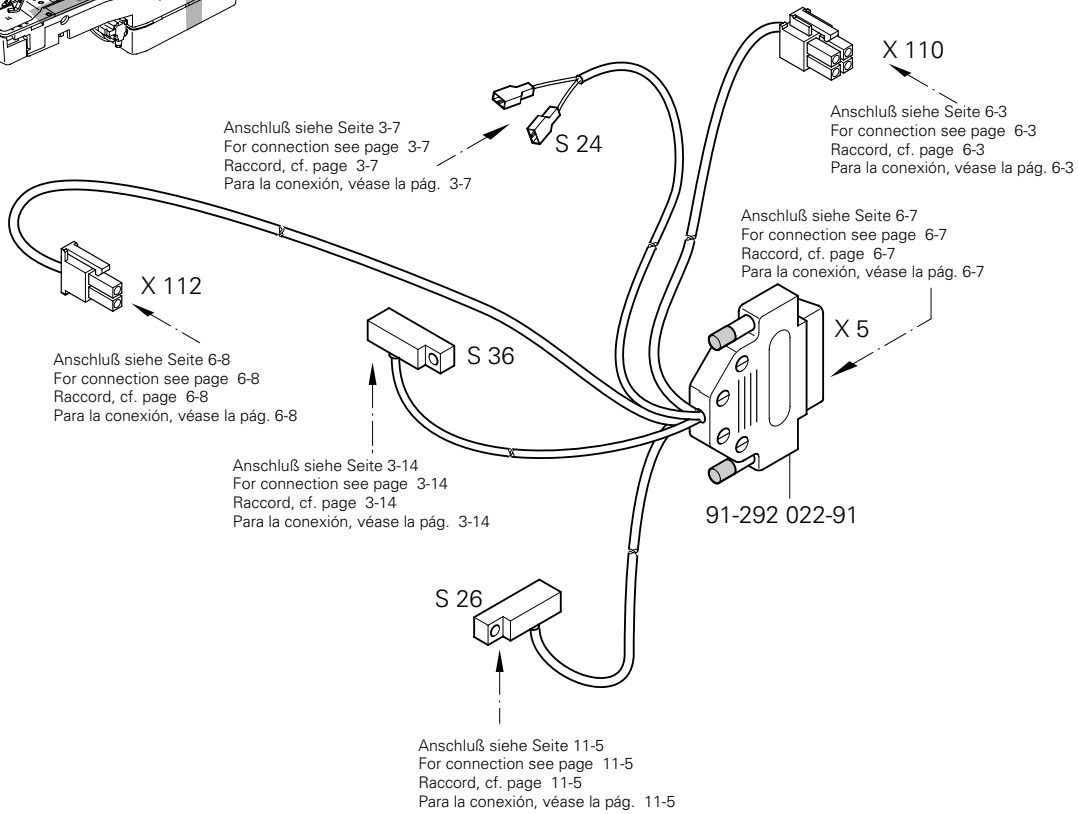

12

Abweichende Teile der PFAFF 3307-5/01 Different parts for PFAFF 3307-5/01 Pièces divergentes de la PFAFF 3307-5/01 Piezas de la PFAFF 3307-5/01 que son diferentes

(die sonstigen Teile wie in Register 3 bis 9)
(for all other parts see Sections 3 to 9)
(les autres pièces comme dans les registres 3 à 9)
(las demás piezas como en los registros 3 al 9)

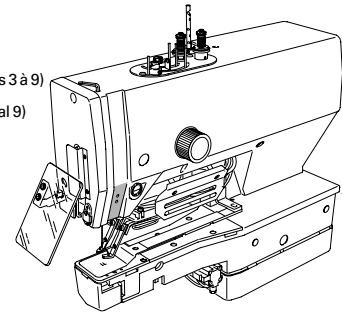

Anschluß siehe Seite 5-1
For connection see page 5-1
Raccord, cf. page 5-1
Para la conexión, véase la pág. 5-1

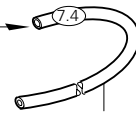

99-135 233-91 (2x)

25-308 820-40 [96]

91-232 922-91

99-137 432-91

25-308 820-40 [96]

Anschluß siehe Seite 5-1
For connection see page 5-1
Raccord, cf. page 5-1
Para la conexión, véase la pág. 5-1

7.2

91-232 792-91

12-005 175-25 (2x)

91-232 794-25

91-233 190-15 (2x)

91-232 793-25

11-130 176-25

11-130 170-25 (2x)

91-232 919-91

12-024 121-25

91-232 790-91

12-305 114-25 (2x)

11-130 173-15 (2x)

12-335 151-25

91-024 536-05

11-130 941-05 (2x)

91-232 782-05

11-330 958-15 (2x)

91-232 784-91

12-624 210-45

91-232 786-05

91-232 787-92

91-232 788-91

91-232 915-25

11-108 846-15 (3x)

11-130 092-15

91-232 913-21

11-108 006-15

91-232 918-05

91-232 796-25

12-710 081-12

13-033 124-05

91-232 916-25

91-232 912-91

☐ siehe Kapitel 2 Erläuterung der Schlüsselzeichen
see chapter 2 Explanation of key markings
voir le chap. 2 Explication des symboles
véase el Cap. 2 Explicaciones de los signos clave

PFAFF

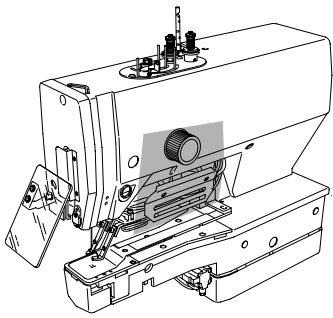

Abweichende Teile der PFAFF 3307-5/01
Different parts for PFAFF 3307-5/01
Pièces divergentes de la PFAFF 3307-5/01
Piezas de la PFAFF 3307-5/01 que son diferentes

(die sonstigen Teile wie in Register 3 bis 9)

(for all other parts see Sections 3 to 9)

(les autres pièces comme dans les registres 3 à 9)

(las demás piezas como en los registros 3 al 9)

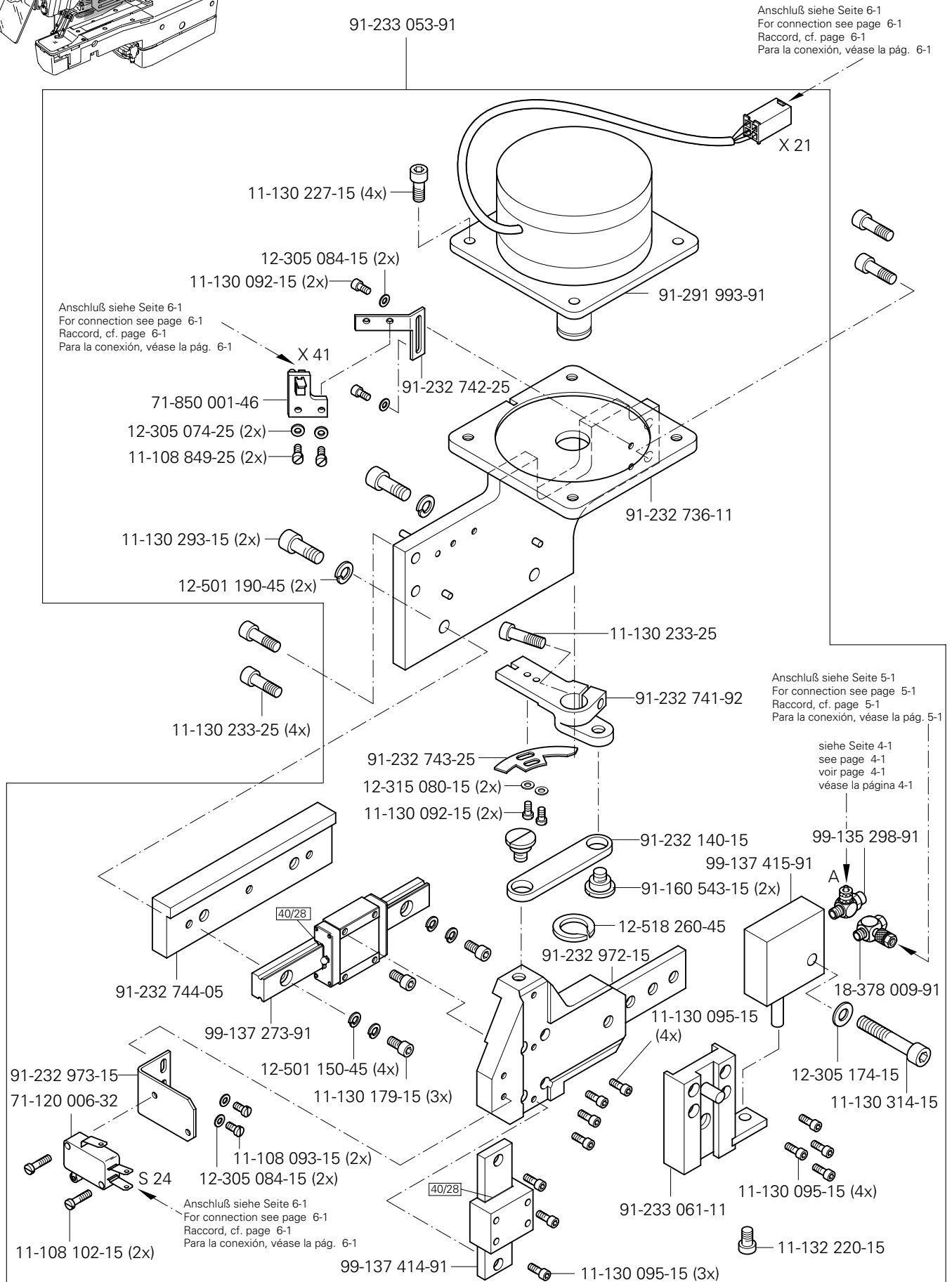

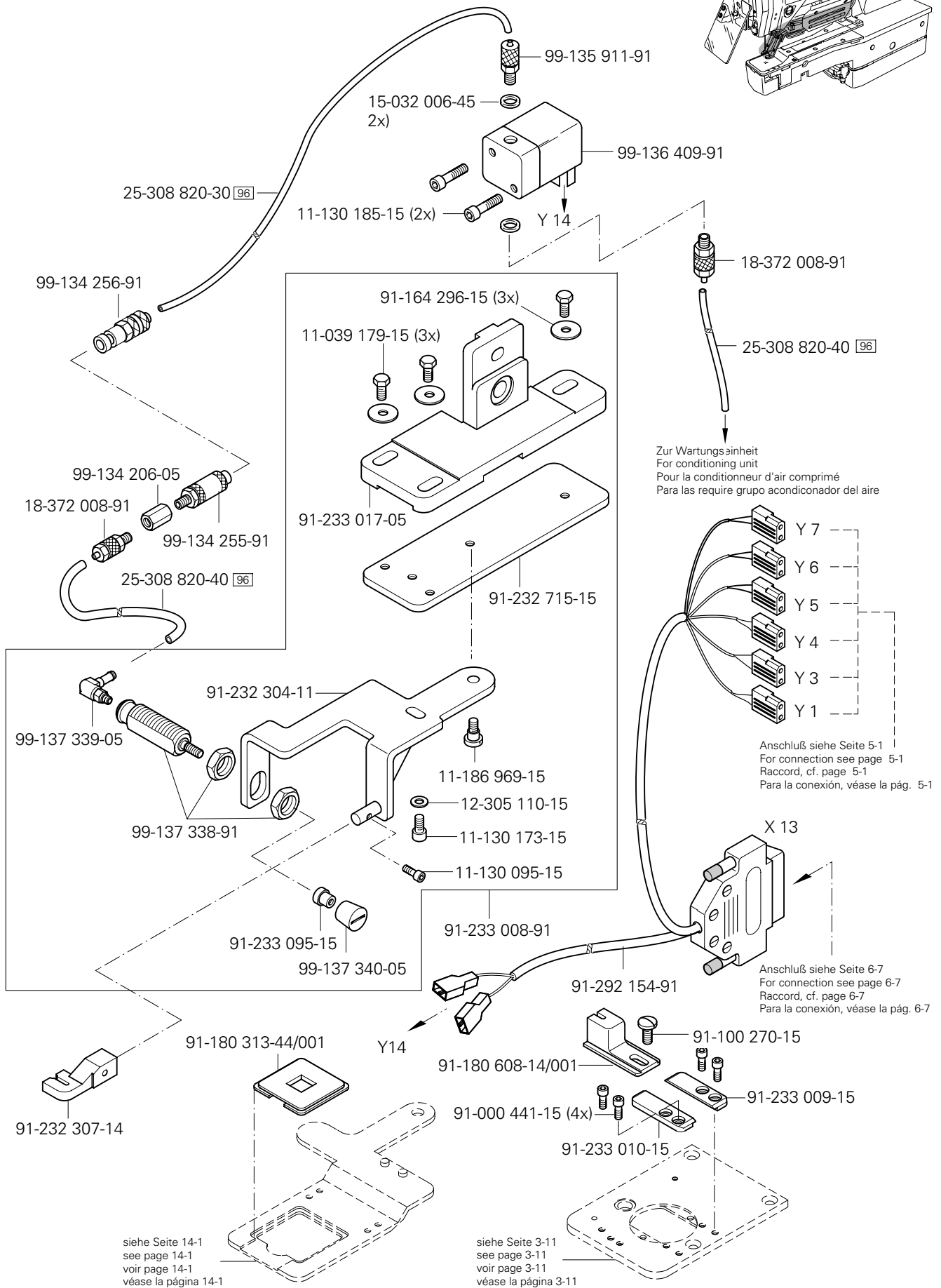
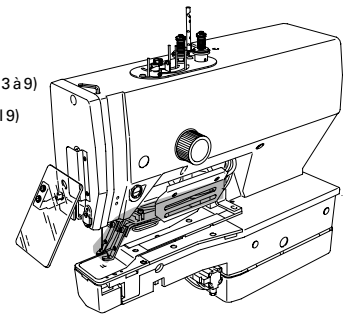

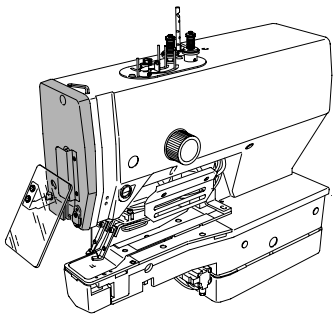

Abweichende Teile der PFAFF 3307-9/01
 Different parts for PFAFF 3307-9/01
 Pièces divergentes de la PFAFF 3307-9/01
 Piezas de la PFAFF 3307-9/01 que son diferentes

(die sonstigen Teile wie in Register 3 bis 9)

(for all other parts see Sections 3 to 9)

(les autres pièces comme dans les registres 3 à 9)

(las demás piezas como en los registros 3 al 9)

91-232 347-71/893

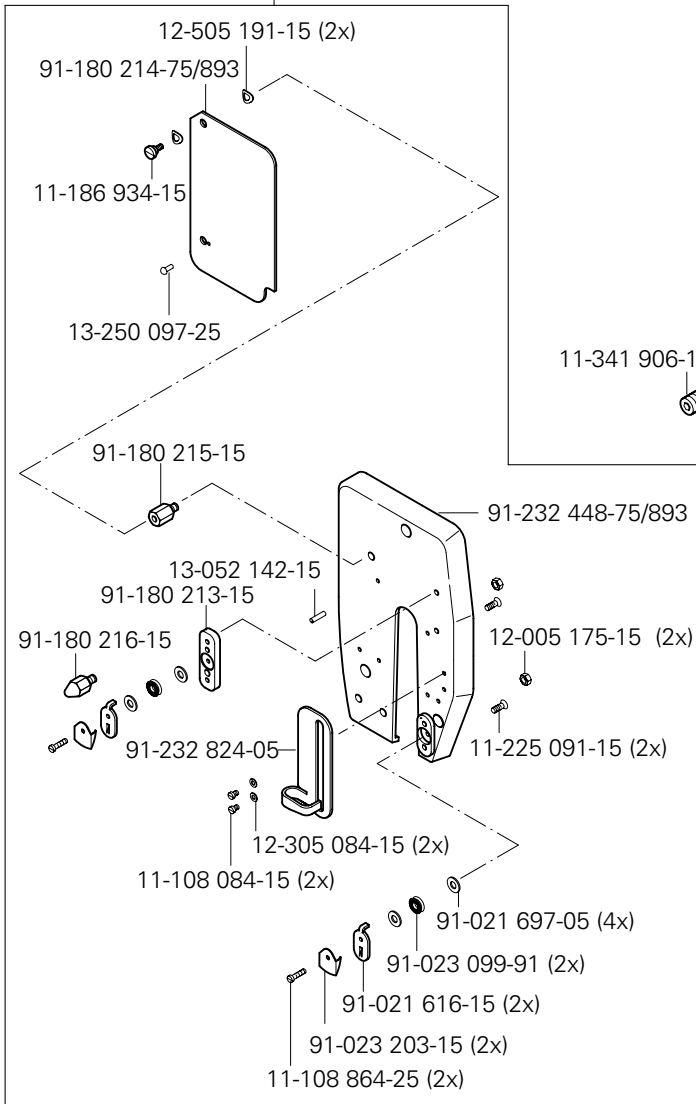

91-232 124-25

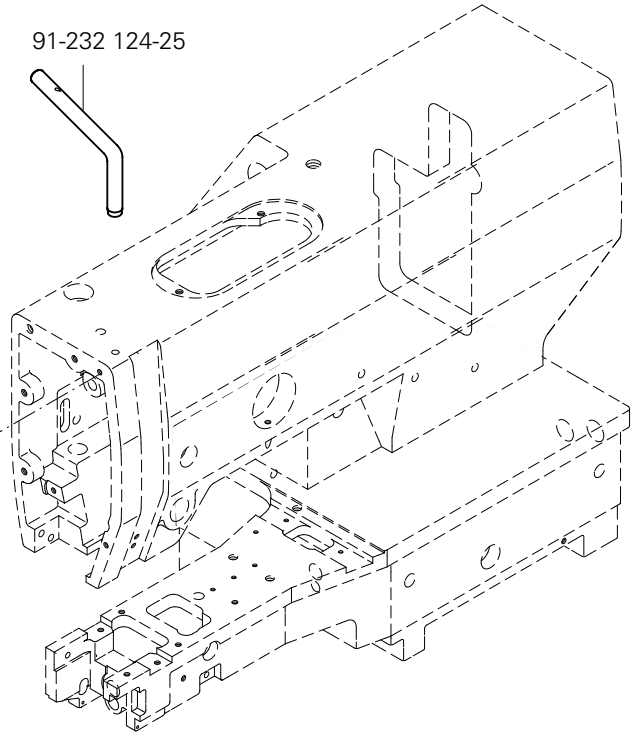

91-180 319-91

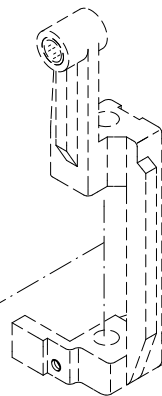
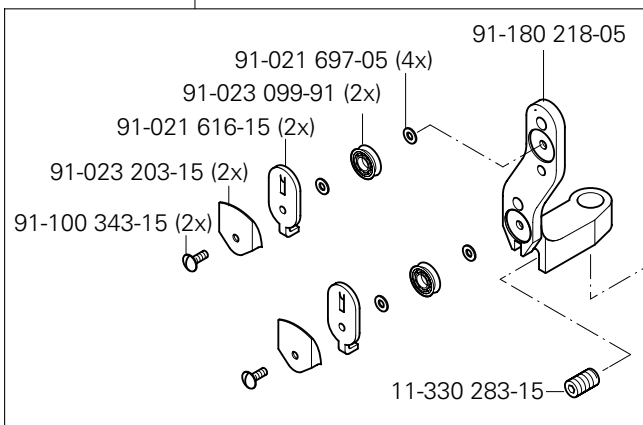

siehe Seite 3-2
 see page 3-2
 voir page 3-2
 véase la página 3-2

13

Abweichende Teile der PFAFF 3307-9/01

Different parts for PFAFF 3307-9/01

Pièces divergentes de la PFAFF 3307-9/01

Piezas de la PFAFF 3307-9/01 que son diferentes

(die sonstigen Teile wie in Register 3 bis 9)

(for all other parts see Sections 3 to 9)

(les autres pièces comme dans les registres 3 à 9)

(las demás piezas como en los registros 3 al 9)

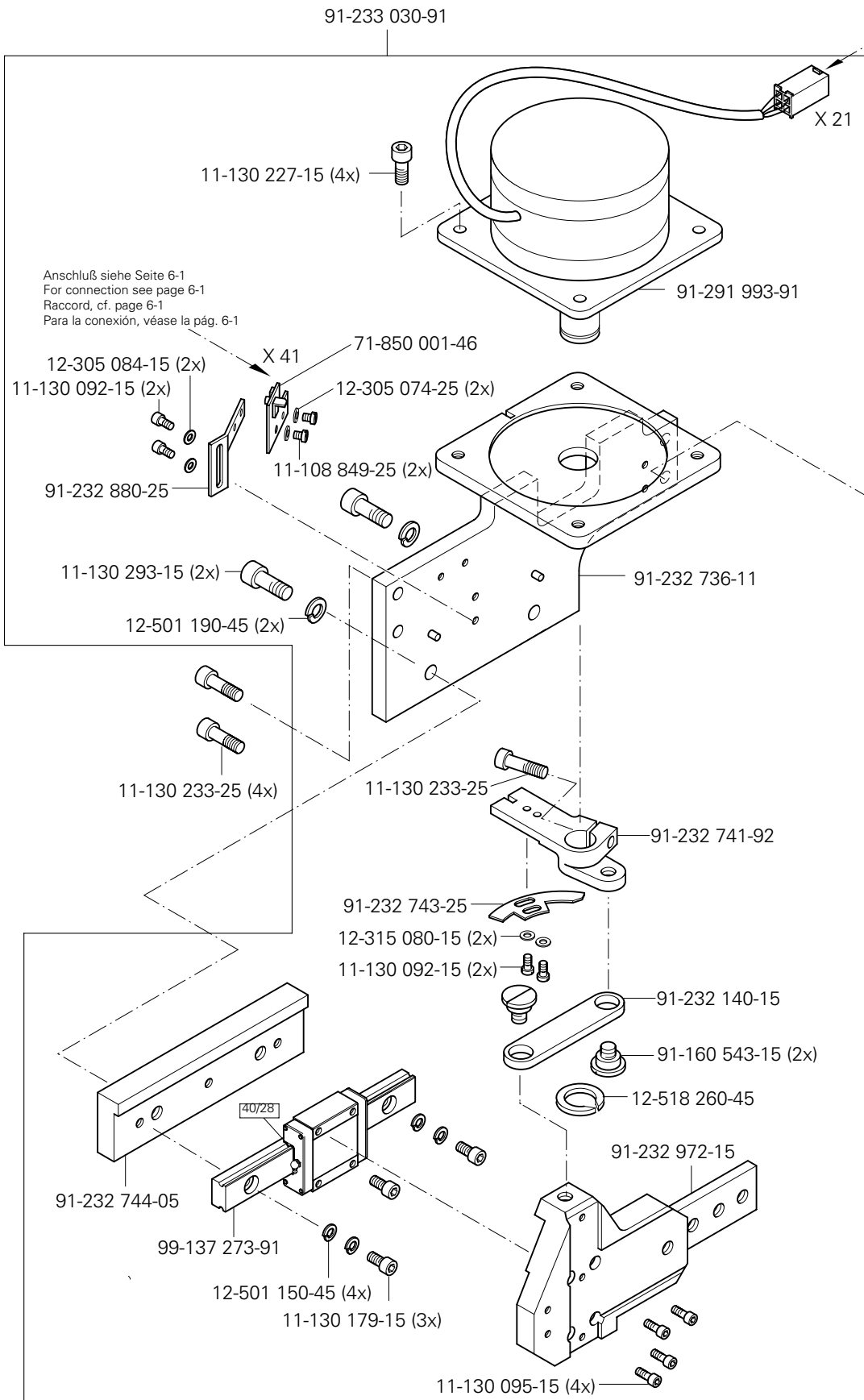
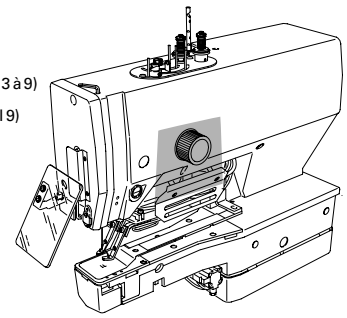

Anschluß siehe Seite 6-1
For connection see page 6-1
Raccord, cf. page 6-1
Para la conexión, véase la pág. 6-1

Anschluß siehe Seite 6-1
For connection see page 6-1
Raccord, cf. page 6-1
Para la conexión, véase la pág. 6-1



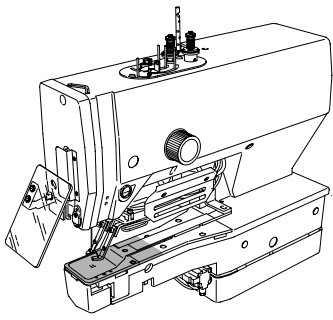

Abweichende Teile der PFAFF 3307-9/01
 Different parts for PFAFF 3307-9/01
 Pièces divergentes de la PFAFF 3307-9/01
 Piezas de la PFAFF 3307-9/01 que son diferentes

(die sonstigen Teile wie in Register 3 bis 9)

(for all other parts see Sections 3 to 9)

(les autres pièces comme dans les registres 3 à 9)

(las demás piezas como en los registros 3 al 9)

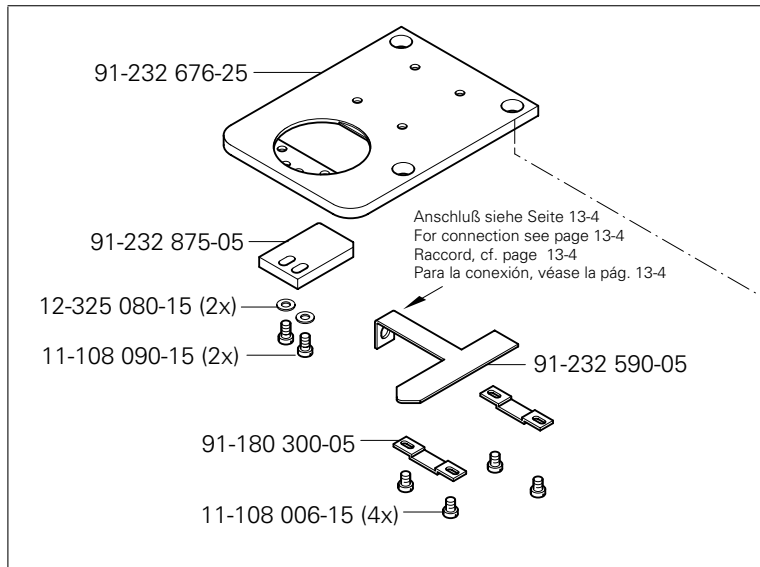
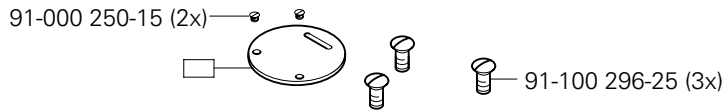

91-232 591-91

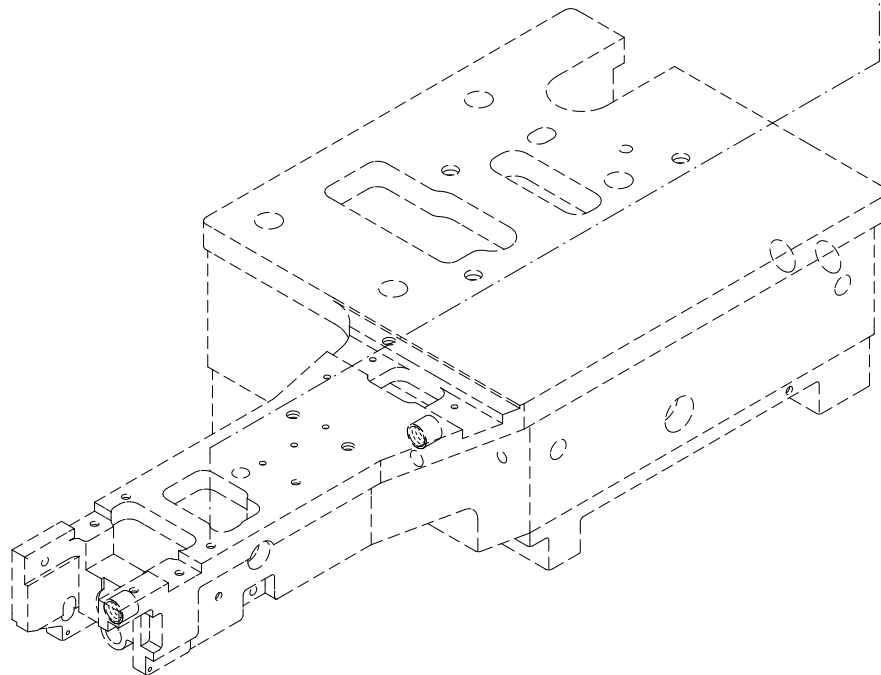

13

Abweichende Teile der PFAFF 3307-9/01

Different parts for PFAFF 3307-9/01

Pièces divergentes de la PFAFF 3307-9/01

Piezas de la PFAFF 3307-9/01 que son diferentes

(die sonstigen Teile wie in Register 3 bis 9)

(for all other parts see Sections 3 to 9)

(les autres pièces comme dans les registres 3 à 9)

(las demás piezas como en los registros 3 al 9)

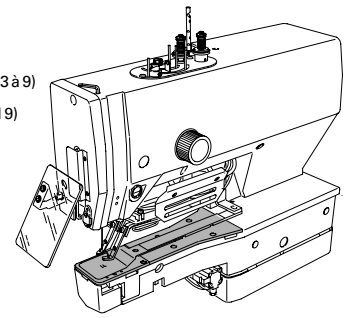

Anschluß siehe Seite 5-1
For connection see page 5-1
Raccord, cf. page 5-1
Para la conexión, véase la pág.5-1

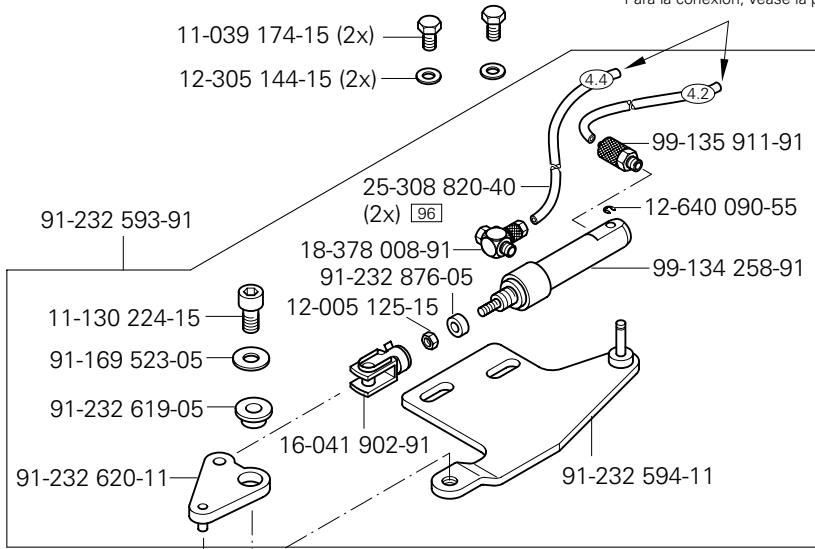

Anschluß siehe Seite 13-5
For connection see page 13-5
Raccord, cf. page 13-5
Para la conexión, véase la pág. 13-5

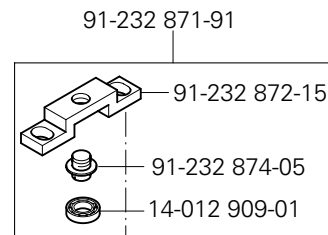
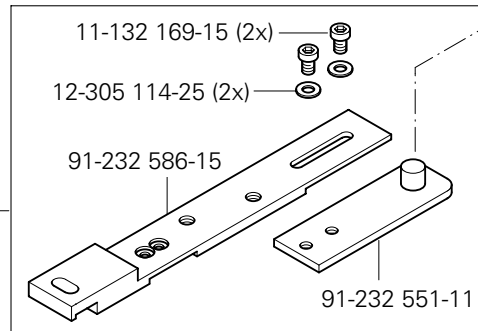

siehe Seite 3-8
see page 3-8
voir page 3-8
véase la página 3-8

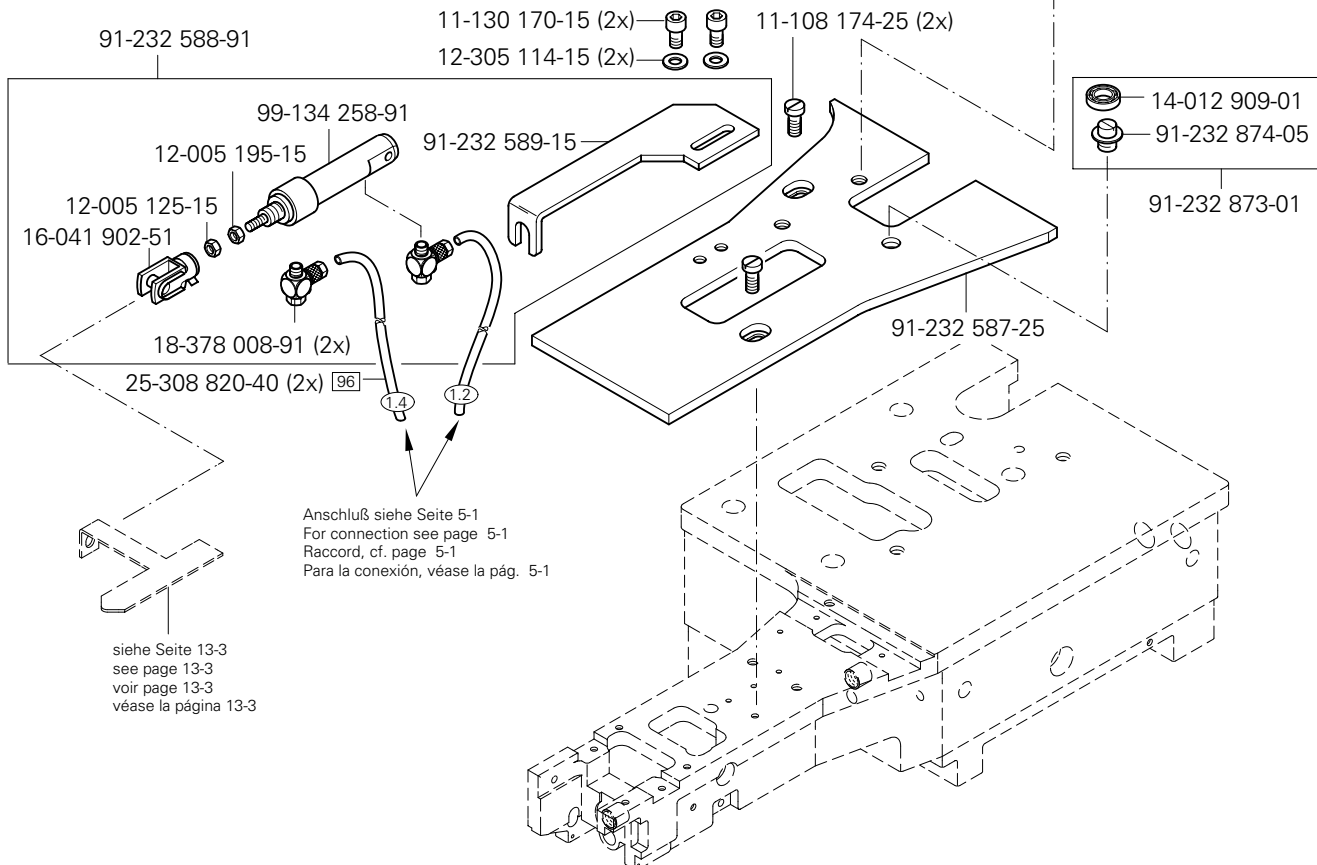

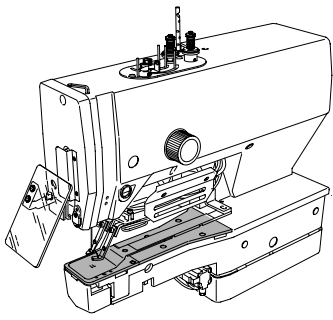

Abweichende Teile der PFAFF 3307-9/01
 Different parts for PFAFF 3307-9/01
 Pièces divergentes de la PFAFF 3307-9/01
 Piezas de la PFAFF 3307-9/01 que son diferentes

(die sonstigen Teile wie in Register 3 bis 9)

(for all other parts see Sections 3 to 9)

(les autres pièces comme dans les registres 3 à 9)

(las demás piezas como en los registros 3 al 9)

91-232 623-91

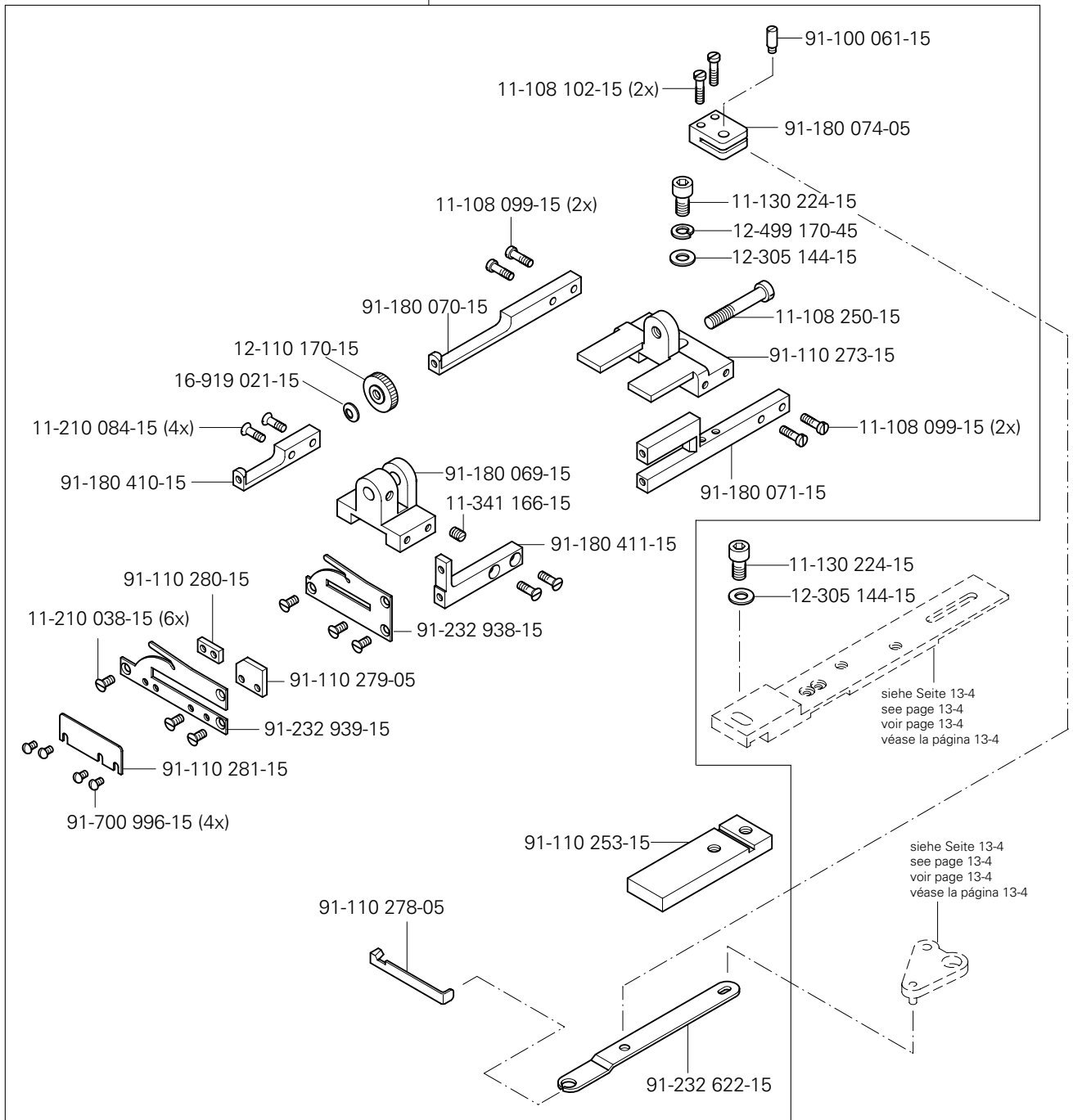

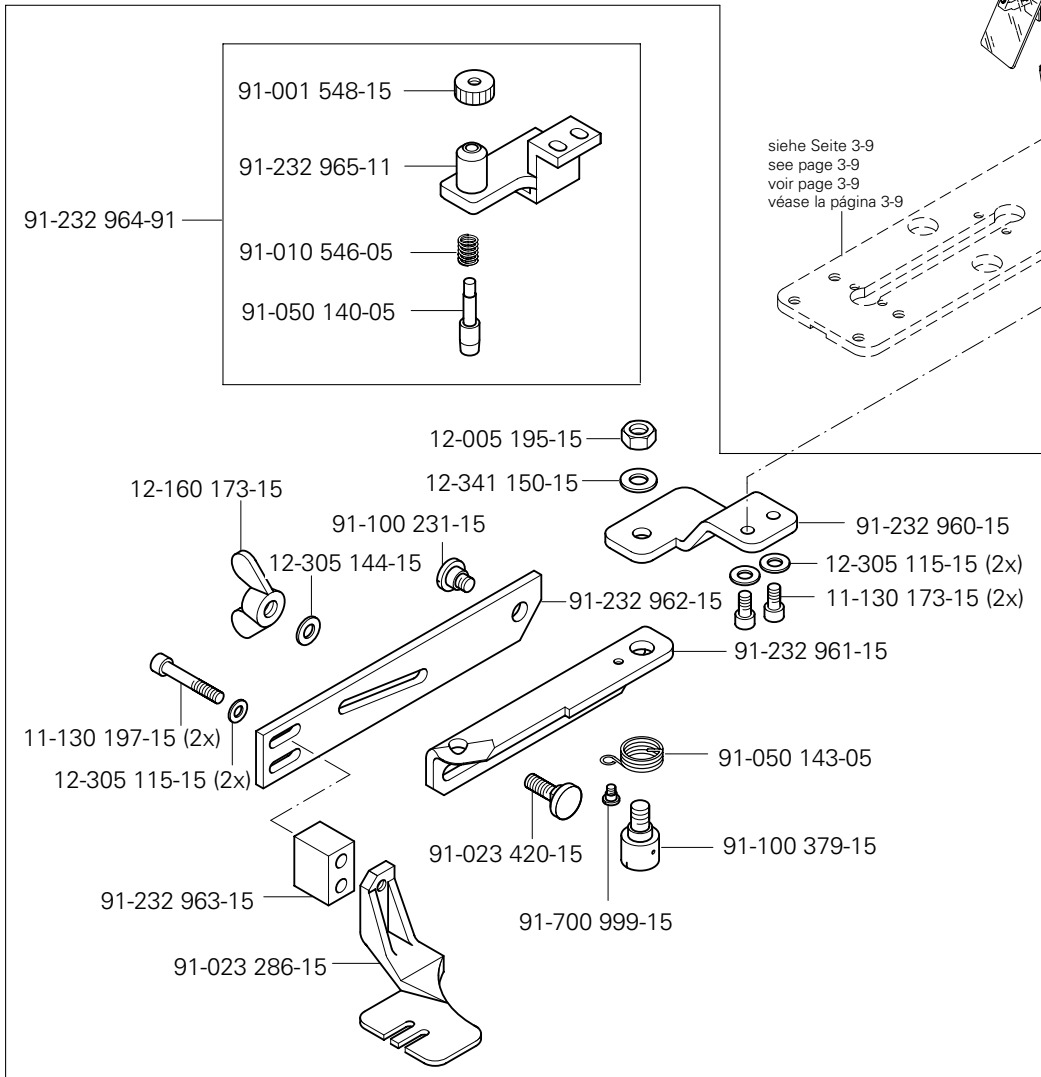
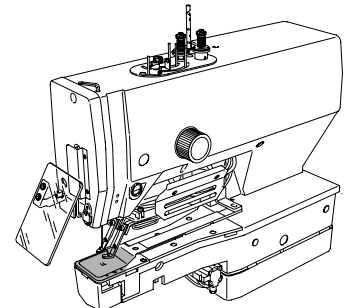

siehe Seite 3-9
 see page 3-9
 voir page 3-9
 véase la página 3-9

91-232 959-90
 (PFAFF 3307 -1/02; -1/03)

91-180 095-91
 (PFAFF 3307 -1/01; 1/02; -1/03; -5/01)

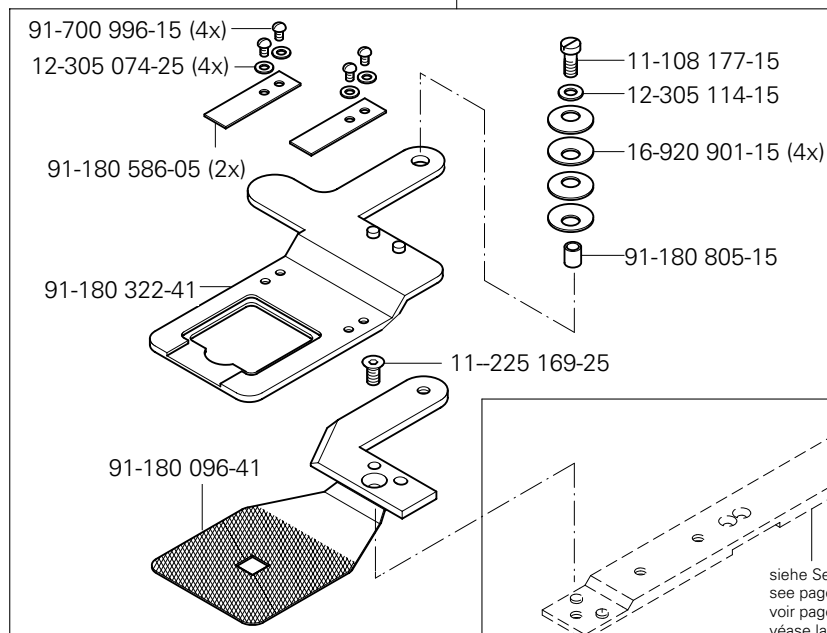

siehe Seite 3-12
 see page 3-12
 voir page 3-12
 véase la página 3-12

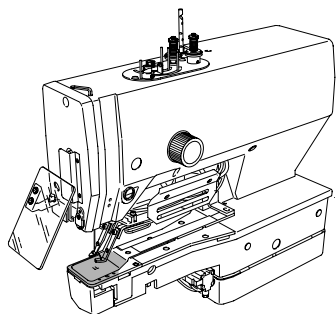

Sonderausführung
 Special version
 Version spéciale
 Tipo especial

PFAFF 3307

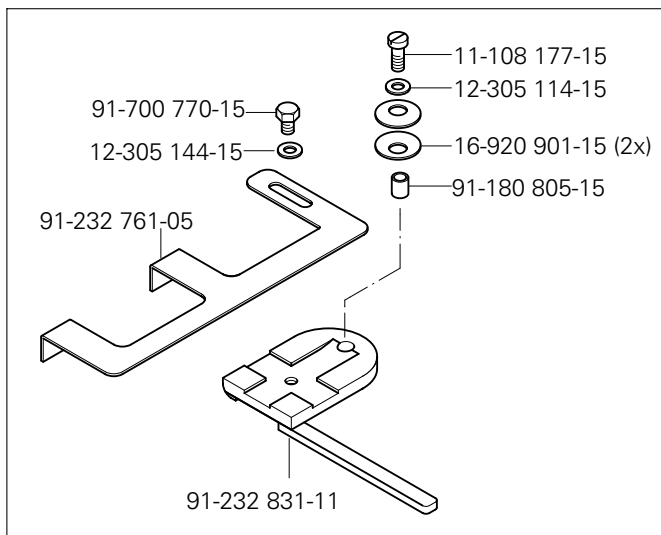

91-232 991-90
 (PFAFF 3307 -1/01; -1/02; -5/01)

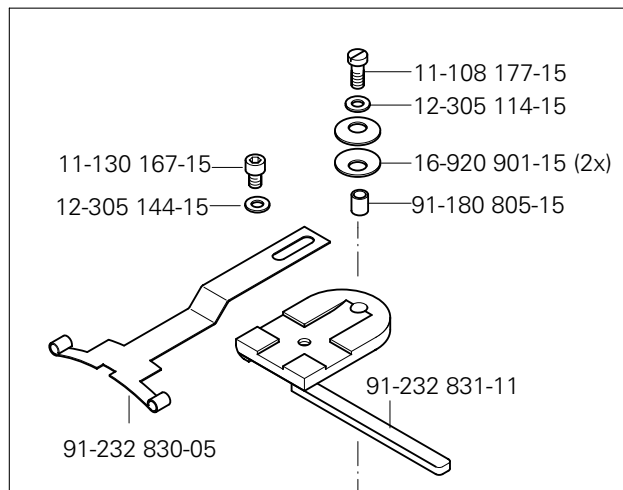

91-232 992-90
 (PFAFF 3307 -1/01; -1/02; -1/03)

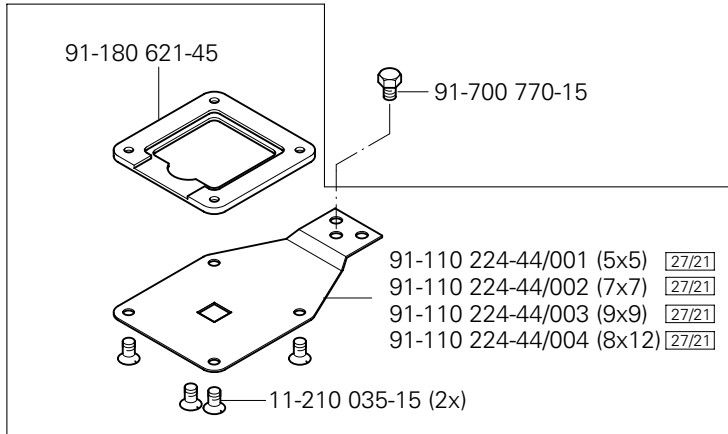
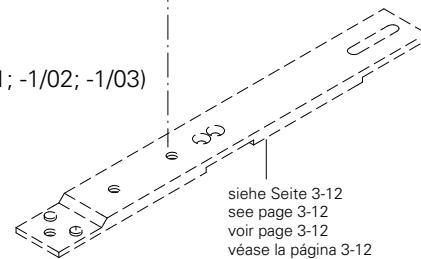

91-180 620-93/001 (5x5) 27/21
 91-180 620-93/002 (7x7) 27/21
 91-180 620-93/003 (9x9) 27/21
 91-180 620-93/004 (8x12) 27/21 } (PFAFF 3307 -1/01; -1/02; -1/03; -5/01)

91-232 975-90 (PFAFF 3307 -1/01)

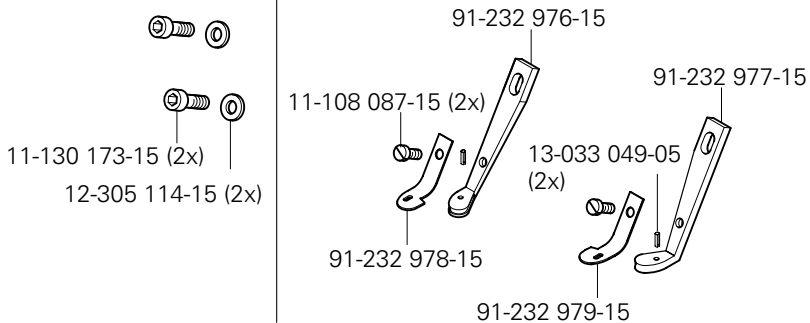

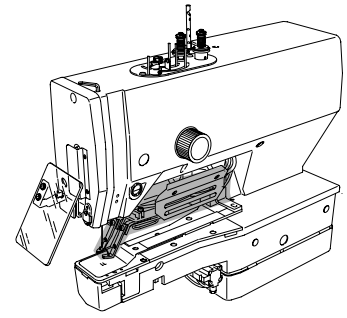

91-232 952-90
 (PFAFF 3307 -1/01; -1/02; -1/03; -5/01)

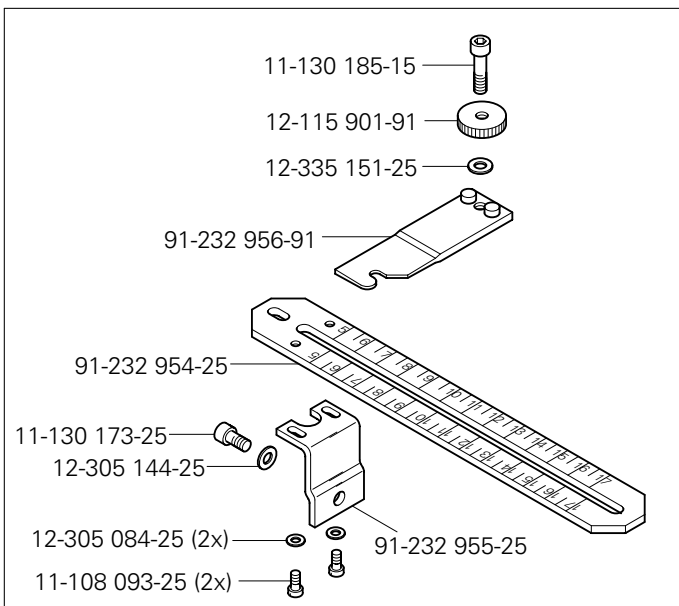
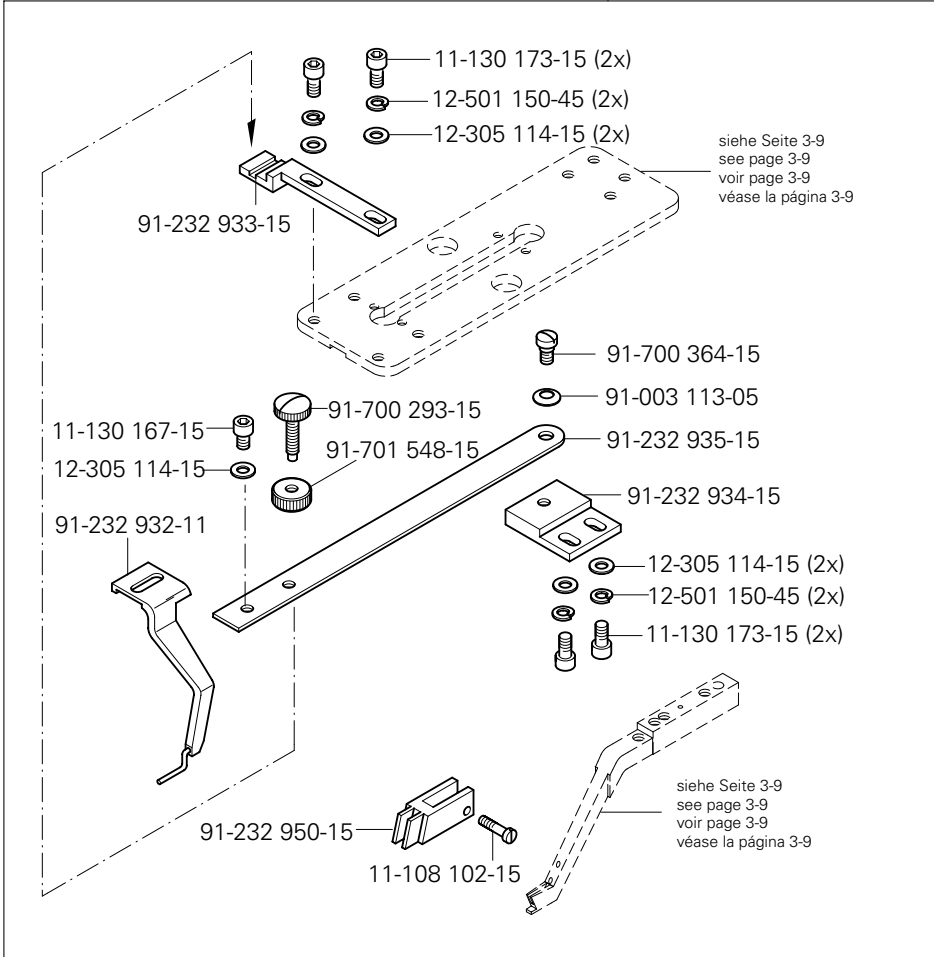

91-232 953-90
 (PFAFF 3307 -1/01; -1/02)

| No. | Seite Page Pages Página | No. | Seite Page Pages Página | No. | Seite Page Pages Página | No. | Seite Page Pages Página |
|---------------|---|---------------|---|---------------|--|---------------|----------------------------------|
| 11-039 174-15 | 13 - 4 | 11-130 092-25 | 10 - 2 | 11-130 287-25 | 6 - 7, 10 - 2, 11 - 7 | 11-210 084-15 | 11 - 8, 13 - 5 |
| 11-039 179-15 | 3 - 9, 10 - 5, 11 - 5, 12 - 3 | 11-130 095-15 | 3 - 7, 11 - 4, 11 - 5, 11 - 8, 12 - 2, 12 - 3, 13 - 2 | 11-130 293-15 | 3 - 4, 3 - 7, 3 - 8, 3 - 15, 10 - 4, 11 - 3, 12 - 2, 13 - 2 | 11-210 165-15 | 10 - 5 |
| 11-039 186-15 | 10 - 2 | | | | | 11-210 168-15 | 3 - 2 |
| 11-039 225-15 | 6 - 4 | 11-130 097-15 | 10 - 5 | 11-130 293-25 | 11 - 8 | 11-210 169-15 | 10 - 5, 11 - 8 |
| 11-039 291-15 | 10 - 3 | 11-130 097-25 | 10 - 2 | 11-130 299-15 | 3 - 5 | 11-210 174-15 | 3 - 14, 10 - 5 |
| 11-039 306-15 | 7 - 1 | 11-130 110-25 | 10 - 2 | 11-130 299-25 | 11 - 5 | 11-210 210-15 | 3 - 1 |
| 11-106 941-25 | 10 - 5 | 11-130 167-15 | 14 - 2, 14 - 3 | 11-130 305-15 | 4 - 1 | 11-225 091-15 | 11 - 1, 11 - 3, 13 - 1 |
| 11-108 006-15 | 10 - 1, 11 - 2, 12 - 1, 13 - 3 | 11-130 170-15 | 3 - 3, 3 - 17, 10 - 5, 13 - 4 | 11-130 314-15 | 3 - 7, 12 - 2 | 11-225 169-25 | 14 - 1 |
| 11-108 084-15 | 3 - 1, 11 - 1, 13 - 1 | 11-130 170-25 | 10 - 1, 11 - 2, 12 - 1 | 11-130 365-15 | 3 - 19, 6 - 4 | 11-225 175-15 | 3 - 14, 11 - 4 |
| 11-108 087-15 | 3 - 6, 3 - 11, 11 - 9, 14 - 2 | 11-130 173-15 | 3 - 2, 3 - 3, 3 - 5, 3 - 6, 3 - 9, 10 - 1, 10 - 5, 11 - 2, 11 - 4, 12 - 1, 12 - 3, 14 - 1, 14 - 2, 14 - 3 | 11-130 371-15 | 3 - 19 | 11-225 178-15 | 11 - 5 |
| 11-108 090-15 | 3 - 11, 11 - 9, 13 - 3 | | | 11-130 395-15 | 3 - 1 | 11-225 178-25 | 3 - 13 |
| 11-108 093-15 | 3 - 7, 12 - 2 | | | 11-130 941-05 | 10 - 1, 11 - 2, 12 - 1 | 11-225 232-15 | 11 - 4 |
| 11-108 093-25 | 14 - 3 | 11-130 173-25 | 14 - 3 | 11-132 169-15 | 3 - 12, 13 - 4 | 11-225 238-15 | 11 - 5, 11 - 7 |
| 11-108 099-15 | 13 - 5 | | | 11-132 220-15 | 3 - 7, 12 - 2 | 11-225 292-15 | 11 - 3 |
| 11-108 102-15 | 3 - 7, 12 - 2, 13 - 5, 14 - 3 | 11-130 176-15 | 3 - 3, 3 - 16, 10 - 5, 11 - 4, 11 - 5, 11 - 7 | 11-132 223-15 | 6 - 4 | 11-225 352-15 | 3 - 1 |
| 11-108 102-25 | 6 - 2 | 11-130 176-25 | 10 - 1, 11 - 2, 12 - 1 | 11-172 085-25 | 10 - 2 | 11-305 176-15 | 10 - 2 |
| 11-108 174-15 | 3 - 16, 6 - 6 | 11-130 179-15 | 3 - 1, 3 - 7, 3 - 15, 12 - 2, 13 - 2 | 11-173 174-15 | 3 - 9 | 11-317 086-15 | 3 - 14 |
| 11-108 174-25 | 3 - 12, 13 - 4 | 11-130 185-15 | 11 - 7, 12 - 3, 14 - 3 | 11-174 176-15 | 3 - 3 | 11-317 094-15 | 3 - 14 |
| 11-108 177-15 | 14 - 1, 14 - 2 | 11-130 191-15 | 11 - 7 | 11-178 220-15 | 11 - 7 | 11-317 184-15 | 3 - 14 |
| 11-108 224-05 | 11 - 7, 11 - 8 | 11-130 191-25 | 10 - 3, 11 - 4 | 11-178 851-15 | 3 - 14 | 11-330 082-15 | 3 - 3 |
| 11-108 225-25 | 11 - 8 | 11-130 197-15 | 3 - 1, 14 - 1 | 11-180 169-05 | 10 - 3 | 11-330 085-15 | 11 - 4 |
| 11-108 250-15 | 13 - 5 | 11-130 206-15 | 5 - 1, 10 - 7, 11 - 10 | 11-180 169-25 | 3 - 1 | 11-330 166-15 | 3 - 5, 3 - 18 |
| 11-108 264-25 | 11 - 7 | 11-130 209-15 | 10 - 3 | 11-180 223-25 | 3 - 1, 6 - 3 | 11-330 169-15 | 10 - 2, 10 - 5 |
| 11-108 846-15 | 10 - 1, 11 - 2, 12 - 1 | 11-130 224-15 | 3 - 2, 3 - 5, 13 - 4, 13 - 5 | 11-186 091-15 | 3 - 14 | 11-330 172-15 | 3 - 4 |
| 11-108 849-15 | 12 - 2 | 11-130 224-25 | 10 - 4 | 11-186 175-15 | 14 - 2 | 11-330 175-15 | 6 - 2 |
| 11-108 849-25 | 3 - 7, 12 - 2, 13 - 2 | 11-130 227-15 | 3 - 7, 3 - 14, 12 - 2, 13 - 2 | 11-186 934-15 | 11 - 1, 13 - 1 | 11-330 205-15 | 6 - 6 |
| 11-108 852-15 | 3 - 12, 11 - 9 | 11-130 233-15 | 3 - 14, 10 - 3, 11 - 3 | 11-186 969-15 | 12 - 3 | 11-330 217-15 | 3 - 15, 3 - 18, 11 - 6 |
| 11-108 855-15 | 3 - 5 | 11-130 233-25 | 3 - 7, 10 - 3, 12 - 2, 13 - 2 | 11-210 035-15 | 11 - 8, 14 - 2 | 11-330 226-15 | 3 - 19, 10 - 2 |
| 11-108 864-25 | 3 - 1, 11 - 1, 13 - 1 | 11-130 239-15 | 3 - 5 | 11-210 038-15 | 13 - 5 | 11-330 232-15 | 11 - 5 |
| 11-130 086-15 | 3 - 12, 3 - 14 | 11-130 251-15 | 11 - 3 | 11-210 041-15 | 3 - 5 | 11-330 277-15 | 3 - 4, 6 - 4 |
| 11-130 092-15 | 3 - 2, 3 - 6, 3 - 7, 10 - 1, 11 - 2, 11 - 8, 12 - 1, 12 - 2, 13 - 2 | 11-130 286-15 | 11 - 3 | 11-210 048-15 | 3 - 1 | 11-330 280-15 | 3 - 2, 3 - 18 |
| | | 11-130 287-15 | 3 - 8 | 11-210 074-15 | 3 - 14 | 11-330 283-15 | 3 - 3, 11 - 1, 13 - 1 |

| No. | Seite Page Pages Página | No. | Seite Page Pages Página | No. | Seite Page Pages Página | No. | Seite Page Pages Página |
|---------------|--|---------------|--|---------------|-----------------------------------|---------------|----------------------------------|
| 11-330 952-15 | 3 - 5, 3 - 19, 10 - 4 | 12-024 231-15 | 3 - 19 | 12-335 151-25 | 10 - 1, 11 - 2, 12 - 1, 14 - 3 | 13-030 344-05 | 10 - 4 |
| 11-330 955-15 | 3 - 6 | 12-082 170-25 | 10 - 3 | 12-335 191-15 | 3 - 4, 4 - 1, 11 - 8 | 13-033 049-05 | 14 - 2 |
| 11-330 958-15 | 10 - 1, 11 - 2, 12 - 1 | 12-105 171-15 | 11 - 6 | 12-335 211-15 | 3 - 1 | 13-033 124-05 | 3 - 6, 10 - 1, 11 - 2, 12 - 1 |
| 11-330 964-15 | 3 - 4, 3 - 18, 10 - 4 | 12-110 170-15 | 11 - 4, 13 - 5 | 12-341 150-15 | 14 - 1 | 13-033 136-05 | 3 - 11, 11 - 9 |
| 11-330 968-91 | 3 - 19 | 12-115 901-91 | 14 - 3 | 12-360 033-05 | 3 - 14 | 13-033 409-05 | 3 - 16 |
| 11-335 184-15 | 3 - 9 | 12-160 173-15 | 14 - 1 | 12-360 040-05 | 3 - 9, 10 - 5 | 13-052 052-55 | 3 - 9 |
| 11-341 166-15 | 13 - 5 | 12-193 211-55 | 11 - 3 | 12-360 043-05 | 3 - 14 | 13-052 061-15 | 3 - 14 |
| 11-341 169-15 | 3 - 5, 3 - 16 | 12-305 064-25 | 3 - 9, 10 - 5 | 12-499 150-45 | 6 - 6, 10 - 7, 11 - 10 | 13-052 142-15 | 11 - 1, 13 - 1 |
| 11-341 901-15 | 3 - 4 | 12-305 074-25 | 3 - 7, 12 - 2, 13 - 2, 14 - 1 | 12-499 170-45 | 13 - 5 | 13-052 247-15 | 3 - 9 |
| 11-341 902-15 | 3 - 18 | 12-305 084-15 | 3 - 1, 3 - 7, 11 - 1, 12 - 2, 13 - 1, 13 - 2 | 12-500 190-45 | 11 - 8 | 13-063 091-05 | 3 - 13 |
| 11-341 906-15 | 6 - 2, 13 - 1 | 12-305 084-25 | 10 - 2, 14 - 3 | 12-501 150-45 | 3 - 7, 12 - 2, 13 - 2, 14 - 3 | 13-068 211-05 | 3 - 18 |
| 11-460 163-15 | 6 - 5 | 12-305 110-15 | 12 - 3 | 12-501 170-45 | 11 - 3 | 13-072 247-05 | 3 - 13 |
| 11-462 250-55 | 6 - 5, 6 - 8 | 12-305 114-15 | 3 - 9, 3 - 12, 3 - 17, 10 - 5, 11 - 4, 11 - 5, 11 - 7, 13 - 4, 14 - 1, 14 - 2, 14 - 3 | 12-501 190-45 | 3 - 7, 12 - 2, 13 - 2 | 13-250 034-05 | 3 - 5 |
| 11-462 403-55 | 10 - 7, 11 - 10 | 12-305 114-25 | 3 - 12, 10 - 1, 11 - 2, 12 - 1, 13 - 4 | 12-505 191-15 | 11 - 1, 13 - 1 | 13-250 097-25 | 11 - 1, 13 - 1 |
| 11-560 253-15 | 11 - 4 | 12-305 115-15 | 14 - 1 | 12-510 170-25 | 6 - 7 | 14-012 909-01 | 13 - 4 |
| 11-724 290-55 | 3 - 1 | 12-305 144-15 | 3 - 15, 11 - 4, 11 - 6, 13 - 4, 13 - 5, 14 - 1, 14 - 2 | 12-518 260-45 | 3 - 7, 12 - 2, 13 - 2 | 14-246 122-01 | 11 - 3 |
| 11-724 470-55 | 3 - 1 | 12-305 144-25 | 14 - 3 | 12-610 210-45 | 3 - 10, 11 - 6 | 14-280 080-01 | 3 - 18, 3 - 19 |
| 12-005 125-15 | 13 - 4 | 12-305 174-15 | 3 - 7, 11 - 3, 12 - 2 | 12-610 270-45 | 3 - 5 | 14-281 080-05 | 3 - 18, 3 - 19 |
| 12-005 154-25 | 3 - 14, 10 - 2 | 12-305 174-25 | 6 - 7, 10 - 2 | 12-610 290-45 | 11 - 7 | 14-755 033-01 | 10 - 3 |
| 12-005 175-15 | 11 - 1, 13 - 1 | 12-305 224-15 | 3 - 1, 6 - 4, 11 - 3, 11 - 5, 11 - 6 | 12-610 380-45 | 3 - 5 | 14-755 053-01 | 11 - 3 |
| 12-005 175-25 | 10 - 1, 10 - 2, 11 - 2, 12 - 1 | 12-305 264-15 | 3 - 19 | 12-618 150-45 | 3 - 9, 3 - 11, 10 - 5, 11 - 9 | 14-755 055-01 | 11 - 3 |
| 12-005 195-15 | 13 - 4, 14 - 1 | 12-315 070-25 | 3 - 5 | 12-618 230-45 | 10 - 4 | 15-032 001-45 | 4 - 1, 10 - 7 |
| 12-024 101-25 | 3 - 1 | 12-315 080-15 | 3 - 7, 3 - 12, 12 - 2, 13 - 2 | 12-624 210-45 | 10 - 1, 11 - 2, 12 - 1 | 15-032 002-45 | 4 - 1, 11 - 10 |
| 12-024 121-15 | 3 - 14 | 12-315 110-25 | 7 - 1 | 12-640 090-55 | 13 - 4, 3 - 13 | 15-032 006-45 | 12 - 3 |
| 12-024 121-25 | 3 - 13, 10 - 1, 10 - 2, 11 - 2, 12 - 1 | 12-315 170-15 | 14 - 2 | 12-640 150-55 | 3 - 14 | 15-711 050-51 | 3 - 19 |
| 12-024 151-25 | 7 - 1, 10 - 5, 10 - 7, 11 - 10 | 12-325 080-05 | 3 - 11, 11 - 9 | 12-640 170-55 | 3 - 14 | 16-041 035-21 | 11 - 5 |
| 12-024 171-15 | 10 - 5 | 12-325 080-15 | 13 - 3 | 12-640 190-55 | 3 - 10, 3 - 15, 3 - 19 | 16-041 902-51 | 3 - 13, 13 - 4 |
| 12-024 171-25 | 3 - 2, 10 - 3, 11 - 8 | 12-335 131-15 | 3 - 2 | 12-640 210-55 | 3 - 15 | 16-041 902-91 | 13 - 4 |
| 12-024 191-15 | 7 - 1, 10 - 3 | | | 12-703 161-12 | 3 - 14 | 16-409 974-05 | 6 - 4 |
| 12-024 191-25 | 3 - 6, 3 - 8, 11 - 3 | | | 12-710 081-12 | 10 - 1, 11 - 2, 12 - 1 | 16-409 979-05 | 3 - 19 |
| 12-024 211-15 | 11 - 3, 11 - 5 | | | 12-710 170-15 | 3 - 6 | 16-409 980-05 | 3 - 18 |
| 12-024 212-15 | 11 - 3 | | | 12-710 230-12 | 10 - 3 | 16-919 010-15 | 3 - 11, 11 - 9 |
| | | | | 13-030 272-05 | 8 - 1 | 16-919 021-15 | 13 - 5 |

| No. | Seite Page Pages Página | No. | Seite Page Pages Página | No. | Seite Page Pages Página | No. | Seite Page Pages Página |
|-------------------|---|-------------------|----------------------------------|-------------------|--|-------------------|--|
| 16-920 901-15 | 14 - 1, 14 - 2 | 71-120 006-32 | 3 - 7, 12 - 2 | 91-010 196-05 | 3 - 5 | 91-110 224-44/002 | 14 - 2 |
| 17-018 060-91 | 3 - 9 | 71-130 004-39 | 6 - 3 | 91-010 546-05 | 14 - 1 | 91-110 224-44/003 | 14 - 2 |
| 18-050 004-91 | 4 - 1 | 71-130 004-40 | 6 - 3 | 91-010 703-92 | 3 - 3 | 91-110 224-44/004 | 14 - 2 |
| 18-272 010-25 | 5 - 1 | 71-250 003-09 | 6 - 3 | 91-021 031-05 | 3 - 3 | 91-110 253-15 | 13 - 5 |
| 18-278 005-91 | 10 - 9 | 71-370 001-08 | 6 - 5 | 91-021 123-05 | 3 - 13 | 91-110 273-15 | 13 - 5 |
| 18-279 010-05 | 4 - 1 | 71-370 001-32 | 3 - 2, 3 - 17 | 91-021 201-05 | 3 - 6 | 91-110 278-05 | 13 - 5 |
| 18-372 001-91 | 5 - 1, 10 - 7 | 71-370 002-92 | 6 - 5 | 91-021 616-15 | 3 - 1, 3 - 3, 11 - 1, 13 - 1 | 91-110 279-05 | 13 - 5 |
| 18-372 002-91 | 5 - 1 | 71-370 003-06 | 6 - 3 | 91-021 655-91 | 3 - 3 | 91-110 280-15 | 13 - 5 |
| 18-372 003-91 | 4 - 1, 11 - 10 | 71-370 003-94 | 6 - 1 | 91-021 656-05 | 3 - 3 | 91-110 281-15 | 13 - 5 |
| 18-372 008-91 | 3 - 2, 10 - 2, 12 - 3 | 71-520 000-64 | 3 - 5 | 91-021 697-05 | 3 - 1, 3 - 3, 11 - 1, 13 - 1 | 91-119 026-25 | 3 - 6 |
| 18-378 001-91 | 5 - 1 | 71-520 006-01 | 6 - 6 | 91-023 099-91 | 3 - 1, 3 - 3, 11 - 1, 13 - 1 | 91-119 421-05 | 3 - 15, 3 - 16 |
| 18-378 008-91 | 10 - 5, 10 - 9, 11 - 4, 11 - 5, 13 - 4 | 71-523 555-63 | 6 - 4 | 91-023 203-15 | 3 - 1, 3 - 3, 11 - 1, 13 - 1 | 91-132 506-05 | 3 - 2 |
| 18-378 009-91 | 3 - 7, 3 - 14, 10 - 9, 12 - 2 | 71-590 007-21 | 6 - 6 | 91-023 286-15 | 14 - 1 | 91-132 508-91 | 3 - 3 |
| 25-308 820-18 | 10 - 2 | 71-590 007-48 | 6 - 5 | 91-023 420-15 | 14 - 1 | 91-132 509-05 | 3 - 3 |
| 25-308 820-25 | 3 - 2 | 71-590 007-58 | 6 - 7 | 91-024 536-05 | 10 - 1, 11 - 2, 12 - 1 | 91-132 551-01 | 3 - 15 |
| 25-308 820-30 | 3 - 14, 10 - 3, 10 - 7, 10 - 9, 11 - 2, 11 - 4, 11 - 5, 11 - 7, 12 - 3 | 71-770 000-64 | 6 - 8 | 91-027 028-05 | 3 - 14 | 91-132 556-02 | 3 - 15 |
| 25-308 820-40 | 3 - 6, 3 - 13, 3 - 14, 4 - 1, 5 - 1, 10 - 1, 10 - 7, 10 - 9, 11 - 10, 12 - 1, 12 - 3, 13 - 4 | 71-850 001-46 | 3 - 5, 3 - 7, 12 - 2, 13 - 2 | 91-050 140-05 | 14 - 1 | 91-132 557-92 | 3 - 15 |
| 25-308 820-60 | 5 - 1 | 91-000 250-15 | 3 - 11, 11 - 9, 13 - 3 | 91-050 143-05 | 14 - 1 | 91-132 568-05 | 3 - 18 |
| 25-921 801-30 | 3 - 3, 3 - 17 | 91-000 441-15 | 12 - 3 | 91-066 373-05 | 3 - 14 | 91-132 621-25 | 3 - 2 |
| 26-534 300-50 | 3 - 3 | 91-001 283-15 | 3 - 15 | 91-069 809-05 | 3 - 1 | 91-132 624-05 | 3 - 2 |
| 26-536 301-09 | 3 - 3, 3 - 17 | 91-001 299-15 | 3 - 15 | 91-088 275-21 | 6 - 3 | 91-132 723-05 | 3 - 2 |
| 28-011 201-45 | 9 - 1 | 91-001 548-15 | 14 - 1 | 91-093 063-05 | 6 - 3 | 91-160 543-15 | 3 - 7, 3 - 9, 10 - 5, 12 - 2, 13 - 2 |
| 28-011 202-10 | 9 - 1 | 91-001 864-04/001 | 3 - 16 | 91-096 064-05 | 3 - 14 | 91-164 155-05 | 3 - 10 |
| 28-011 202-69 | 9 - 1 | 91-001 864-04/002 | 3 - 16 | 91-100 061-15 | 13 - 5 | 91-164 296-15 | 3 - 9, 10 - 5, 12 - 3 |
| 61-111 600-01 | 8 - 1 | 91-001 864-04/003 | 3 - 16 | 91-100 231-15 | 14 - 1 | 91-168 319-12 | 3 - 15, 3 - 16 |
| 61-111 600-35/001 | 8 - 1 | 91-001 864-04/004 | 3 - 16 | 91-100 270-15 | 3 - 9, 12 - 3 | 91-168 385-05 | 3 - 1 |
| 61-111 635-66 | 8 - 1 | 91-001 864-04/005 | 3 - 16 | 91-100 296-25 | 3 - 11, 11 - 8, 11 - 9, 13 - 3 | 91-169 132-15 | 3 - 2 |
| 61-111 635-92 | 8 - 1 | 91-002 061-05 | 14 - 2 | 91-100 343-15 | 3 - 3, 3 - 9, 10 - 5, 11 - 1, 13 - 1 | 91-169 137-05 | 3 - 10 |
| 61-111 637-03 | 8 - 1 | 91-002 065-05 | 3 - 6 | 91-100 379-15 | 14 - 1 | 91-169 384-15 | 3 - 14 |
| | | 91-003 113-05 | 14 - 3 | 91-106 044-05 | 3 - 5 | 91-169 523-05 | 13 - 4 |
| | | 91-004 005-05 | 3 - 2 | 91-110 160-15 | 3 - 9 | 91-174 438-25 | 3 - 6 |
| | | 91-004 006-05 | 3 - 2 | 91-110 224-44/001 | 14 - 2 | 91-174 439-25 | 3 - 6 |
| | | 91-010 116-05 | 3 - 2 | | | | |

| No. | Seite Page Pages Página | No. | Seite Page Pages Página | No. | Seite Page Pages Página | No. | Seite Page Pages Página |
|-------------------|----------------------------------|-------------------|----------------------------------|-------------------|----------------------------------|-------------------|----------------------------------|
| 91-180 069-15 | 13 - 5 | 91-180 938-05 | 3 - 15 | 91-232 039-91 | 3 - 5 | 91-232 188-05 | 3 - 19 |
| 91-180 070-15 | 13 - 5 | 91-180 939-91 | 3 - 18 | 91-232 041-01 | 3 - 15 | 91-232 194-91 | 3 - 6 |
| 91-180 071-15 | 13 - 5 | 91-187 386-15 | 4 - 1 | 91-232 043-05 | 3 - 12 | 91-232 207-91 | 3 - 19 |
| 91-180 074-05 | 13 - 5 | 91-187 426-70/893 | 4 - 1 | 91-232 044-91 | 3 - 19 | 91-232 226-91 | 3 - 14 |
| 91-180 095-91 | 14 - 1 | 91-188 456-05 | 10 - 4 | 91-232 045-05 | 3 - 19 | 91-232 227-15 | 3 - 14 |
| 91-180 096-41 | 14 - 1 | 91-229 068-75/895 | 7 - 1 | 91-232 078-11 | 3 - 3 | 91-232 228-15 | 3 - 14 |
| 91-180 213-15 | 11 - 1, 13 - 1 | 91-229 069-75/895 | 7 - 1 | 91-232 079-15 | 3 - 3 | 91-232 230-91 | 3 - 14 |
| 91-180 214-75/893 | 11 - 1, 13 - 1 | 91-229 070-70/895 | 7 - 1 | 91-232 080-15 | 3 - 3 | 91-232 283-15 | 3 - 9 |
| 91-180 215-15 | 11 - 1, 13 - 1 | 91-229 071-25 | 7 - 1 | 91-232 081-92 | 3 - 4 | 91-232 304-11 | 12 - 3 |
| 91-180 216-15 | 11 - 1, 13 - 1 | 91-229 072-45 | 7 - 1 | 91-232 089-91 | 3 - 4 | 91-232 307-14 | 12 - 3 |
| 91-180 218-05 | 11 - 1, 13 - 1 | 91-229 073-71/895 | 7 - 1 | 91-232 091-91 | 3 - 18 | 91-232 324-71/893 | 3 - 1 |
| 91-180 300-05 | 13 - 3 | 91-229 074-05 | 7 - 1 | 91-232 096-15 | 3 - 11, 11 - 9 | 91-232 325-75/893 | 3 - 1 |
| 91-180 313-44/001 | 12 - 3 | 91-229 075-45 | 7 - 1 | 91-232 098-15 | 3 - 11, 11 - 9 | 91-232 347-71/893 | 11 - 1, 13 - 1 |
| 91-180 319-91 | 11 - 1, 13 - 1 | 91-229 076-75/698 | 7 - 1 | 91-232 100-15 | 3 - 13 | 91-232 361-92 | 3 - 19 |
| 91-180 322-41 | 14 - 1 | 91-229 077-72/895 | 7 - 1 | 91-232 101-11 | 3 - 19 | 91-232 386-92 | 3 - 4 |
| 91-180 405-05 | 3 - 2 | 91-229 078-25 | 7 - 1 | 91-232 104-91 | 3 - 15 | 91-232 390-15 | 3 - 14 |
| 91-180 410-15 | 13 - 5 | 91-229 080-25 | 7 - 1 | 91-232 106-91 | 3 - 10 | 91-232 392-05 | 3 - 11, 11 - 9 |
| 91-180 411-15 | 13 - 5 | 91-229 081-25 | 7 - 1 | 91-232 110-01 | 3 - 18 | 91-232 393-05 | 3 - 11, 11 - 9 |
| 91-180 586-05 | 14 - 1 | 91-229 123-25 | 7 - 1 | 91-232 114-91 | 3 - 15 | 91-232 394-05 | 3 - 11, 11 - 9 |
| 91-180 608-14/001 | 12 - 3 | 91-229 124-25 | 7 - 1 | 91-232 116-91 | 3 - 19 | 91-232 395-05 | 3 - 11, 11 - 9 |
| 91-180 620-93/001 | 14 - 2 | 91-229 125-25 | 7 - 1 | 91-232 124-25 | 13 - 1 | 91-232 397-05 | 11 - 7 |
| 91-180 620-93/002 | 14 - 2 | 91-229 128-25 | 7 - 1 | 91-232 134-15 | 3 - 13 | 91-232 399-25 | 11 - 5 |
| 91-180 620-93/003 | 14 - 2 | 91-229 129-25 | 7 - 1 | 91-232 140-15 | 3 - 7, 12 - 2, 13 - 2 | 91-232 400-91 | 11 - 5 |
| 91-180 620-93/004 | 14 - 2 | 91-229 180-90 | 6 - 5 | 91-232 142-05 | 3 - 13 | 91-232 401-91 | 11 - 5 |
| 91-180 621-45 | 14 - 2 | 91-232 003-91 | 3 - 14 | 91-232 152-01 | 3 - 11, 11 - 9 | 91-232 403-91 | 11 - 5 |
| 91-180 805-15 | 14 - 1, 14 - 2 | 91-232 004-91 | 3 - 14 | 91-232 168-72/893 | 3 - 1 | 91-232 404-05 | 11 - 5 |
| 91-180 913-11 | 3 - 14 | 91-232 005-11 | 3 - 14 | 91-232 168-75/893 | 3 - 1 | 91-232 410-75/895 | 11 - 6 |
| 91-180 916-05 | 3 - 14 | 91-232 008-05 | 3 - 14 | 91-232 175-15 | 3 - 1 | 91-232 411-05 | 11 - 6 |
| 91-180 923-92 | 3 - 18 | 91-232 010-91 | 3 - 14 | 91-232 179-92 | 3 - 18 | 91-232 412-05 | 11 - 6 |
| 91-180 924-05 | 3 - 16 | 91-232 014-91 | 3 - 14 | 91-232 180-05 | 3 - 19 | 91-232 413-15 | 11 - 6 |
| 91-180 925-91 | 3 - 16 | 91-232 019-71/895 | 3 - 13 | 91-232 183-05 | 3 - 18 | 91-232 414-92 | 11 - 6 |
| 91-180 927-91 | 3 - 16 | 91-232 026-91 | 3 - 2 | 91-232 185-92 | 3 - 18 | 91-232 415-15 | 11 - 5 |
| 91-180 933-92 | 3 - 16 | 91-232 027-01 | 3 - 2 | 91-232 187-05 | 3 - 19 | 91-232 416-15 | 11 - 8 |

| No. | Seite Page Pages Página | No. | Seite Page Pages Página | No. | Seite Page Pages Página | No. | Seite Page Pages Página |
|-------------------|----------------------------------|---------------|----------------------------------|-------------------|----------------------------------|-------------------|----------------------------------|
| 91-232 417-15 | 11 - 8 | 91-232 591-91 | 13 - 3 | 91-232 728-15 | 3 - 9 | 91-232 793-25 | 10 - 1, 11 - 2, 12 - 1 |
| 91-232 420-15 | 11 - 8 | 91-232 593-91 | 13 - 4 | 91-232 731-15 | 3 - 9 | 91-232 794-25 | 10 - 1, 11 - 2, 12 - 1 |
| 91-232 423-15 | 11 - 8 | 91-232 594-11 | 13 - 4 | 91-232 732-05 | 3 - 9 | 91-232 796-25 | 10 - 1, 11 - 2, 12 - 1 |
| 91-232 445-92 | 3 - 19 | 91-232 607-91 | 3 - 6 | 91-232 736-11 | 3 - 7, 12 - 2, 13 - 2 | 91-232 811-05 | 11 - 5 |
| 91-232 448-75/893 | 11 - 1, 13 - 1 | 91-232 608-91 | 3 - 6 | 91-232 740-15 | 3 - 8 | 91-232 823-15 | 11 - 4 |
| 91-232 468-15 | 11 - 4 | 91-232 609-21 | 3 - 6 | 91-232 741-92 | 3 - 7, 12 - 2, 13 - 2 | 91-232 824-05 | 3 - 1, 11 - 1, 13 - 1 |
| 91-232 470-15 | 11 - 4 | 91-232 612-05 | 3 - 14 | 91-232 742-25 | 3 - 7, 12 - 2 | 91-232 825-75/893 | 3 - 1 |
| 91-232 471-15 | 11 - 4 | 91-232 613-12 | 3 - 15 | 91-232 743-25 | 3 - 7, 12 - 2, 13 - 2 | 91-232 826-15 | 3 - 2 |
| 91-232 472-04/002 | 11 - 4 | 91-232 619-05 | 13 - 4 | 91-232 744-05 | 3 - 7, 12 - 2, 13 - 2 | 91-232 830-05 | 14 - 2 |
| 91-232 491-15 | 3 - 13 | 91-232 620-11 | 13 - 4 | 91-232 746-05 | 3 - 1 | 91-232 831-11 | 14 - 2 |
| 91-232 501-01 | 3 - 15 | 91-232 622-15 | 13 - 5 | 91-232 747-75/895 | 3 - 1 | 91-232 834-91 | 10 - 5 |
| 91-232 504-91 | 3 - 4 | 91-232 623-91 | 13 - 5 | 91-232 748-75/895 | 3 - 1 | 91-232 840-15 | 10 - 5 |
| 91-232 505-05 | 3 - 4 | 91-232 624-91 | 13 - 4 | 91-232 749-75/895 | 3 - 8 | 91-232 841-91 | 10 - 5 |
| 91-232 506-05 | 3 - 4 | 91-232 657-15 | 3 - 13 | 91-232 750-91 | 3 - 7 | 91-232 843-15 | 10 - 5 |
| 91-232 507-01 | 3 - 4 | 91-232 672-91 | 3 - 12 | 91-232 756-15 | 11 - 4 | 91-232 844-91 | 10 - 5 |
| 91-232 508-05 | 3 - 4 | 91-232 673-25 | 3 - 11 | 91-232 761-05 | 14 - 2 | 91-232 846-91 | 10 - 5 |
| 91-232 509-01 | 3 - 3 | 91-232 676-25 | 13 - 3 | 91-232 762-05 | 3 - 2 | 91-232 847-15 | 10 - 5 |
| 91-232 512-01 | 3 - 17 | 91-232 678-91 | 3 - 11 | 91-232 763-91 | 3 - 2 | 91-232 852-93/001 | 10 - 2 |
| 91-232 523-05 | 3 - 2 | 91-232 681-01 | 3 - 3 | 91-232 764-05 | 11 - 3 | 91-232 853-21 | 10 - 2 |
| 91-232 532-91 | 11 - 4 | 91-232 682-05 | 3 - 3 | 91-232 765-15 | 11 - 3 | 91-232 856-15 | 10 - 2 |
| 91-232 533-91 | 11 - 5 | 91-232 683-05 | 3 - 3 | 91-232 768-15 | 11 - 3 | 91-232 857-25 | 10 - 2 |
| 91-232 539-75/895 | 10 - 7, 11 - 10 | 91-232 684-05 | 3 - 17 | 91-232 769-25 | 11 - 3 | 91-232 858-05 | 10 - 2 |
| 91-232 543-05 | 11 - 5 | 91-232 688-05 | 3 - 6 | 91-232 770-91 | 3 - 9 | 91-232 859-25 | 10 - 2 |
| 91-232 548-05 | 11 - 3 | 91-232 693-11 | 3 - 6 | 91-232 773-91 | 11 - 3 | 91-232 860-25 | 10 - 2 |
| 91-232 551-11 | 3 - 12, 13 - 4 | 91-232 695-05 | 3 - 14 | 91-232 774-91 | 11 - 3 | 91-232 862-25 | 10 - 2 |
| 91-232 552-15 | 3 - 12 | 91-232 696-91 | 3 - 15 | 91-232 782-05 | 10 - 1, 11 - 2, 12 - 1 | 91-232 863-91 | 10 - 2 |
| 91-232 553-25 | 3 - 12 | 91-232 700-91 | 3 - 5 | 91-232 784-91 | 10 - 1, 11 - 2, 12 - 1 | 91-232 865-25 | 10 - 2 |
| 91-232 572-21 | 3 - 6 | 91-232 701-91 | 3 - 5 | 91-232 786-05 | 10 - 1, 11 - 2, 12 - 1 | 91-232 866-92 | 10 - 2 |
| 91-232 586-15 | 13 - 4 | 91-232 702-12 | 3 - 5 | 91-232 787-92 | 10 - 1, 11 - 2, 12 - 1 | 91-232 871-91 | 13 - 4 |
| 91-232 587-25 | 13 - 4 | 91-232 711-15 | 10 - 5 | 91-232 788-91 | 10 - 1, 11 - 2, 12 - 1 | 91-232 872-15 | 13 - 4 |
| 91-232 588-91 | 13 - 4 | 91-232 715-15 | 12 - 3 | 91-232 790-91 | 10 - 1, 11 - 2, 12 - 1 | 91-232 873-01 | 13 - 4 |
| 91-232 589-15 | 13 - 4 | 91-232 726-15 | 3 - 9 | 91-232 792-91 | 10 - 1, 11 - 2, 12 - 1 | 91-232 874-05 | 13 - 4 |
| 91-232 590-05 | 13 - 3 | 91-232 727-15 | 3 - 9 | | | 91-232 875-05 | 13 - 3 |

| No. | Seite Page Pages Página | No. | Seite Page Pages Página | No. | Seite Page Pages Página | No. | Seite Page Pages Página |
|-------------------|----------------------------------|-------------------|----------------------------------|-------------------|----------------------------------|-------------------|----------------------------------|
| 91-232 876-05 | 13 - 4 | 91-232 953-90 | 14 - 3 | 91-233 009-15 | 12 - 3 | 91-233 101-21 | 10 - 2 |
| 91-232 877-91 | 9 - 1 | 91-232 954-25 | 14 - 3 | 91-233 010-15 | 12 - 3 | 91-233 120-05 | 3 - 6 |
| 91-232 880-25 | 13 - 2 | 91-232 955-25 | 14 - 3 | 91-233 012-75/895 | 10 - 2 | 91-233 158-25 | 3 - 6 |
| 91-232 881-25 | 10 - 3 | 91-232 956-91 | 14 - 3 | 91-233 013-01 | 10 - 4 | 91-233 192-71/895 | 11 - 6 |
| 91-232 883-92 | 10 - 4 | 91-232 959-90 | 14 - 1 | 91-233 015-25 | 10 - 2 | 91-233 163-91 | 11 - 6 |
| 91-232 884-25 | 10 - 3 | 91-232 960-15 | 14 - 1 | 91-233 017-05 | 12 - 3 | 91-233 180-91 | 4 - 1 |
| 91-232 885-91 | 10 - 3 | 91-232 961-15 | 14 - 1 | 91-233 024-91 | 3 - 2 | 91-233 185-05 | 11 - 7 |
| 91-232 890-21 | 10 - 3 | 91-232 963-15 | 14 - 1 | 91-233 025-05 | 3 - 2 | 91-233 190-15 | 10 - 1, 11 - 2, 12 - 1 |
| 91-232 891-91 | 10 - 3 | 91-232 964-91 | 14 - 1 | 91-233 026-15 | 11 - 7 | 91-233 200-91 | 5 - 1, 10 - 7, 11 - 10 |
| 91-232 901-12 | 10 - 4 | 91-232 965-11 | 14 - 1 | 91-233 027-15 | 11 - 8 | 91-233 213-91 | 3 - 13 |
| 91-232 902-05 | 10 - 5 | 91-232 969-01 | 6 - 2 | 91-233 030-91 | 13 - 2 | 91-233 214-11 | 3 - 13 |
| 91-232 910-70/895 | 10 - 3 | 91-232 971-11 | 3 - 7 | 91-233 034-91 | 11 - 9 | 91-233 220-90 | 10 - 8 |
| 91-232 912-91 | 10 - 1, 11 - 2, 12 - 1 | 91-232 972-15 | 3 - 7, 12 - 2, 13 - 2 | 91-233 035-91 | 11 - 7 | 91-233 300-71/895 | 10 - 7 |
| 91-232 913-21 | 10 - 1, 11 - 2, 12 - 1 | 91-232 973-15 | 3 - 7, 12 - 2 | 91-233 036-91 | 11 - 7 | 91-233 301-71/895 | 11 - 10 |
| 91-232 915-25 | 10 - 1, 11 - 2, 12 - 1 | 91-232 975-90 | 14 - 2 | 91-233 053-91 | 12 - 2 | 91-262 385-75/893 | 6 - 6 |
| 91-232 916-25 | 10 - 1, 11 - 2, 12 - 1 | 91-232 976-15 | 14 - 2 | 91-233 061-11 | 12 - 2 | 91-266 398-05 | 3 - 4 |
| 91-232 918-05 | 10 - 1, 11 - 2, 12 - 1 | 91-232 977-15 | 14 - 2 | 91-233 065-91 | 5 - 1 | 91-267 712-92 | 3 - 5 |
| 91-232 919-91 | 10 - 1, 11 - 2, 12 - 1 | 91-232 978-15 | 14 - 2 | 91-233 074-05 | 10 - 8 | 91-269 003-91 | 3 - 4 |
| 91-232 922-91 | 10 - 1, 11 - 2, 12 - 1 | 91-232 979-15 | 14 - 2 | 91-233 075-04 | 10 - 8 | 91-269 027-11 | 3 - 4, 6 - 4 |
| 91-232 923-21 | 10 - 2 | 91-232 988-25 | 11 - 9 | 91-233 076-05 | 10 - 8 | 91-269 046-91 | 6 - 4 |
| 91-232 924-05 | 11 - 9 | 91-232 989-05 | 11 - 7 | 91-233 077-05 | 10 - 8 | 91-269 047-15 | 6 - 4 |
| 91-232 929-15 | 10 - 5 | 91-232 990-15 | 11 - 8 | 91-233 078-05 | 10 - 8 | 91-269 061-92 | 3 - 4 |
| 91-232 930-15 | 10 - 5 | 91-232 991-90 | 14 - 2 | 91-233 079-01 | 10 - 8 | 91-269 082-75/895 | 3 - 1 |
| 91-232 932-11 | 14 - 3 | 91-232 992-90 | 14 - 2 | 91-233 082-05 | 10 - 9 | 91-269 163-71/895 | 3 - 1 |
| 91-232 933-15 | 14 - 3 | 91-232 993-15 | 10 - 5 | 91-233 083-05 | 10 - 8 | 91-269 266-05 | 3 - 11, 11 - 9 |
| 91-232 934-15 | 14 - 3 | 91-232 994-05 | 10 - 5 | 91-233 085-05 | 10 - 8 | 91-269 507-91 | 3 - 5 |
| 91-232 935-15 | 14 - 3 | 91-232 995-91 | 10 - 5 | 91-233 087-05 | 10 - 8 | 91-269 508-05 | 3 - 5 |
| 91-232 938-15 | 13 - 5 | 91-232 999-15 | 10 - 5 | 91-233 088-04/001 | 10 - 8 | 91-269 509-05 | 3 - 5 |
| 91-232 939-15 | 13 - 5 | 91-233 000-05 | 10 - 5 | 91-233 088-04/002 | 10 - 8 | 91-269 512-05 | 3 - 5 |
| 91-232 946-91 | 3 - 9 | 91-233 002-75/895 | 10 - 3 | 91-233 088-04/003 | 10 - 8 | 91-269 513-05 | 3 - 5 |
| 91-232 947-15 | 3 - 9 | 91-233 003-93/001 | 10 - 4 | 91-233 090-05 | 10 - 8 | 91-269 514-05 | 3 - 5 |
| 91-232 950-15 | 14 - 3 | 91-233 007-92 | 10 - 4 | 91-233 094-05 | 3 - 15 | 91-291 458-91 | 6 - 7 |
| 91-232 952-90 | 14 - 3 | 91-233 008-91 | 12 - 3 | 91-233 095-15 | 12 - 3 | 91-291 664-91 | 6 - 2 |

| No. | Seite Page Pages Página | No. | Seite Page Pages Página | No. | Seite Page Pages Página | No. | Seite Page Pages Página |
|-------------------|----------------------------------|---------------|---|---------------|----------------------------------|-----|----------------------------------|
| 91-291 899-91 | 6 - 7 | 99-134 207-05 | 10 - 5, 11 - 7 | 99-137 339-05 | 12 - 3 | | |
| 91-291 990-91 | 6 - 1 | 99-134 255-91 | 12 - 3 | 99-137 340-05 | 12 - 3 | | |
| 91-291 991-91 | 6 - 2 | 99-134 256-91 | 12 - 3 | 99-137 344-91 | 3 - 14 | | |
| 91-291 993-91 | 3 - 7, 12 - 2, 13 - 2 | 99-134 258-91 | 3 - 13, 13 - 4 | 99-137 353-91 | 3 - 12 | | |
| 91-292 022-91 | 11 - 11 | 99-134 392-01 | 3 - 9, 10 - 5 | 99-137 374-91 | 3 - 4 | | |
| 91-292 084-91 | 6 - 1 | 99-134 394-05 | 3 - 1 | 99-137 375-91 | 3 - 1 | | |
| 91-292 100-91 | 6 - 8 | 99-134 452-91 | 5 - 1 | 99-137 381-91 | 11 - 7 | | |
| 91-292 127-91 | 6 - 3 | 99-134 621-01 | 10 - 2, 10 - 7 | 99-137 384-91 | 3 - 18 | | |
| 91-292 128-91 | 6 - 8 | 99-134 794-05 | 3 - 1 | 99-137 392-91 | 11 - 5 | | |
| 91-292 129-91 | 10 - 6 | 99-135 029-91 | 10 - 9 | 99-137 393-91 | 11 - 4 | | |
| 91-292 130-91 | 6 - 1 | 99-135 233-91 | 3 - 2, 10 - 1, 10 - 3, 10 - 5, 11 - 2, 11 - 4, 11 - 5, 11 - 7, 12 - 1 | 99-137 394-91 | 11 - 4 | | |
| 91-292 140-91 | 10 - 10 | | | 99-137 395-91 | 11 - 7 | | |
| 91-292 153-91 | 6 - 1 | 99-135 298-91 | 3 - 7, 12 - 2 | 99-137 396-91 | 11 - 5 | | |
| 91-292 154-91 | 12 - 3 | 99-135 350-91 | 5 - 1 | 99-137 397-91 | 11 - 6 | | |
| 91-292 155-91 | 10 - 6, 11 - 11 | 99-135 490-91 | 3 - 13, 11 - 7 | 99-137 407-91 | 10 - 5 | | |
| 91-700 249-15 | 3 - 11, 11 - 9 | 99-135 496-95 | 4 - 1 | 99-137 408-91 | 10 - 3 | | |
| 91-700 293-15 | 14 - 3 | 99-135 549-91 | 3 - 6, 10 - 7 | 99-137 409-91 | 10 - 3 | | |
| 91-700 335-25 | 3 - 2, 11 - 9 | 99-135 617-95 | 3 - 6 | 99-137 410-91 | 10 - 3 | | |
| 91-700 364-15 | 14 - 3 | 99-135 835-05 | 3 - 14, 10 - 7, 11 - 10 | 99-137 411-91 | 10 - 5 | | |
| 91-700 388-15 | 3 - 2 | 99-135 911-91 | 3 - 13, 10 - 5, 10 - 9, 12 - 3, 13 - 4 | 99-137 412-91 | 10 - 2 | | |
| 91-700 770-15 | 3 - 12 | 99-136 071-95 | 10 - 3 | 99-137 413-91 | 10 - 2 | | |
| 91-700 785-15 | 3 - 15, 3 - 16 | 99-136 072-95 | 3 - 6, 4 - 1, 10 - 7, 11 - 10 | 99-137 414-91 | 3 - 7, 12 - 2 | | |
| 91-700 996-15 | 13 - 5, 14 - 1 | 99-136 409-91 | 12 - 3 | 99-137 415-91 | 3 - 7, 12 - 2 | | |
| 91-700 999-15 | 14 - 1 | 99-136 546-91 | 4 - 1 | 99-137 420-91 | 11 - 8 | | |
| 91-701 548-15 | 14 - 3 | 99-136 854-55 | 6 - 6, 6 - 7 | 99-137 422-91 | 11 - 7, 11 - 8 | | |
| 95-215 000-05/107 | 3 - 6 | 99-137 151-45 | 3 - 4 | 99-137 425-91 | 10 - 8 | | |
| 95-215 000-05/116 | 3 - 6 | 99-137 196-05 | 6 - 6 | 99-137 432-91 | 10 - 1, 11 - 2, 12 - 1 | | |
| 95-215 000-05/427 | 3 - 6 | 99-137 234-91 | 4 - 1, 10 - 7, 11 - 10 | 99-137 433-91 | 5 - 1 | | |
| 95-665 735-91 | 9 - 1 | 99-137 272-05 | 10 - 7, 11 - 10 | 99-137 435-05 | 11 - 8 | | |
| 99-116 739-91 | 10 - 9 | 99-137 273-91 | 3 - 7, 12 - 2, 13 - 2 | | | | |
| 99-133 042-91 | 5 - 1, 10 - 7, 11 - 10 | 99-137 328-91 | 11 - 5 | | | | |
| 99-134 206-05 | 3 - 2, 10 - 2, 10 - 7, 12 - 3 | 99-137 338-91 | 12 - 3 | | | | |

PFAFF

3307

Unterklassen-Ausstattung

Subclass parts

Composition des sous-classes

Composición de las subclases

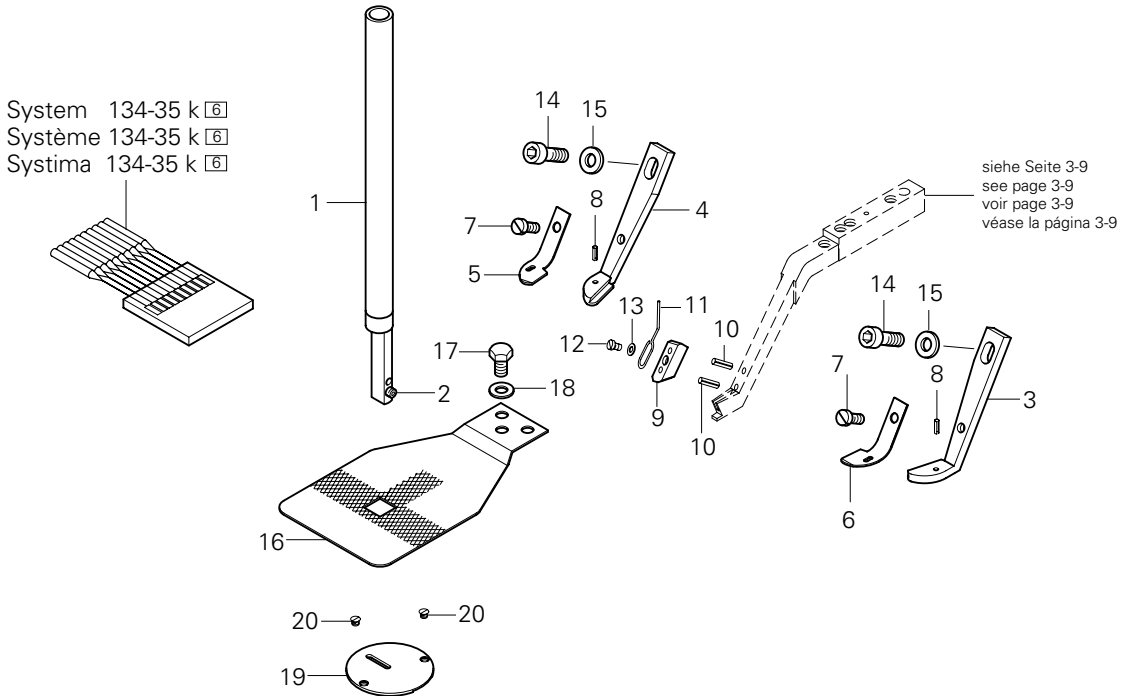

| Pos.-Nr. Item No. N° pos. N° de pos. | Stichlochdurchmesser in mm Needle hole diameter in mm Diamètre du trou d'aiguille en mm Diámetro del agujero pasante para la aguja en mm. | Nähfeldgröße Size of sewing area Dimensions du champ de couture Tamaño del campo de costura | Teile-Nr. Part No. N° de piezas N° de pieza |
|---|--|--|--|
| 1 - 2 | | | 91-132 644-91 |
| 2 | | | 11-330 082-15 |
| 3 - 8 | | | 91-232 288-90 |
| 3 | | | 91-232 289-15 |
| 4 | | | 91-232 290-15 |
| 5 | | | 91-132 640-15 |
| 6 | | | 91-132 642-15 |
| 7 | | | 11-108 087-15 |
| 8 | | | 13-033 049-05 |
| 9 | | | 91-232 767-15 |
| 10 | | | 13-052 055-55 |
| 11 | | | 91-232 766-05 |
| 12 | | | 11-172 085-25 |

| Pos.-Nr. Item No. N° pos. N° de pos. | Stichlochdurchmesser in mm Needle hole diameter in mm Diamètre du trou d'aiguille en mm Diámetro del agujero pasante para la aguja en mm. | Nähfeldgröße Size of sewing area Dimensions du champ de couture Tamaño del campo de costura | Teile-Nr. Part No. N° de piezas N° de pieza |
|---|--|--|--|
| 13 | | | 12-305 084-25 |
| 14 | | | 11-130 173-15 |
| 15 | | | 12-305 114-15 |
| 16 | | 7 x 7 8 x 9 5 x 5 6 x 6 8 x 8 8 x 12 | 91-232 725-24/001 91-232 725-24/002 91-232 725-24/003 91-232 725-24/004 91-232 725-24/005 91-232 725-24/006 |
| 17 | | | 91-700 770-15 |
| 18 | | | 12-305 114-15 |
| 19 | 1,2 1,4 1,6 | | 91-232 674-24/001 91-232 674-24/002 91-232 674-24/003 |
| 20 | | | 91-000 250-15 |

-1/02

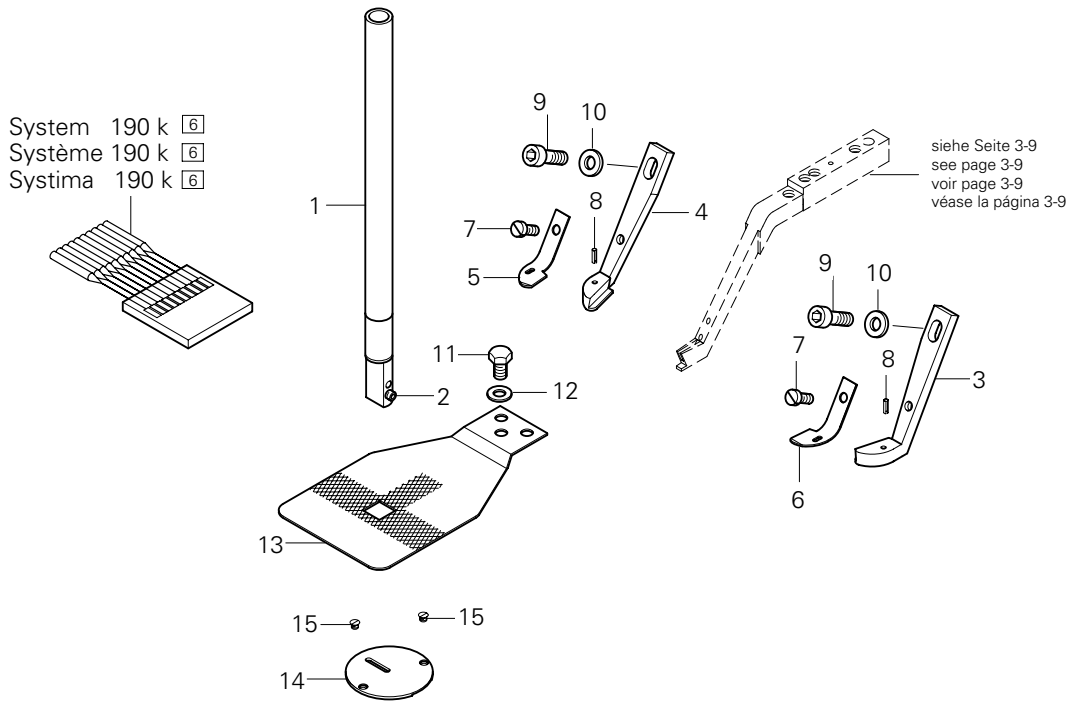

| Pos.-Nr. Item No. N° pos. N° de pos. | Stichlochdurchmesser in mm Needle hole diameter in mm Diamètre du trou d'aiguille en mm Diámetro del agujero pasante para la aguja en mm. | Nähfeldgröße Size of sewing area Dimensions du champ de couture Tamaño del campo de costura | Teile-Nr. Part No. N° de pièces N° de pieza |
|---|--|--|--|
| 1 - 2 | | | 91-021 845-91 |
| 2 | | | 11-330 082-15 |
| 3 - 8 | | | 91-232 697-90 |
| 3 | | | 91-232 698-15 |
| 4 | | | 91-232 699-15 |
| 5 | | | 91-132 640-15 |
| 6 | | | 91-132 642-15 |
| 7 | | | 11-108 087-15 |
| 8 | | | 13-033 049-05 |
| 9 | | | 11-130 173-15 |

| Pos.-Nr. Item No. N° pos. N° de pos. | Stichlochdurchmesser in mm Needle hole diameter in mm Diamètre du trou d'aiguille en mm Diámetro del agujero pasante para la aguja en mm. | Nähfeldgröße Size of sewing area Dimensions du champ de couture Tamaño del campo de costura | Teile-Nr. Part No. N° de pièces N° de pieza |
|---|--|--|--|
| 10 | | | 12-305 114-15 |
| 11 | | | 91-700 770-15 |
| 12 | | | 12-305 114-15 |
| 13 | | 7 x 7 8 x 9 5 x 5 6 x 6 8 x 8 8 x 12 | 91-232 725-24/001 91-232 725-24/002 91-232 725-24/003 91-232 725-24/004 91-232 725-24/005 91-232 725-24/006 |
| 14 | 1,8 | | 91-232 674-24/004 |
| 15 | | | 91-000 250-15 |



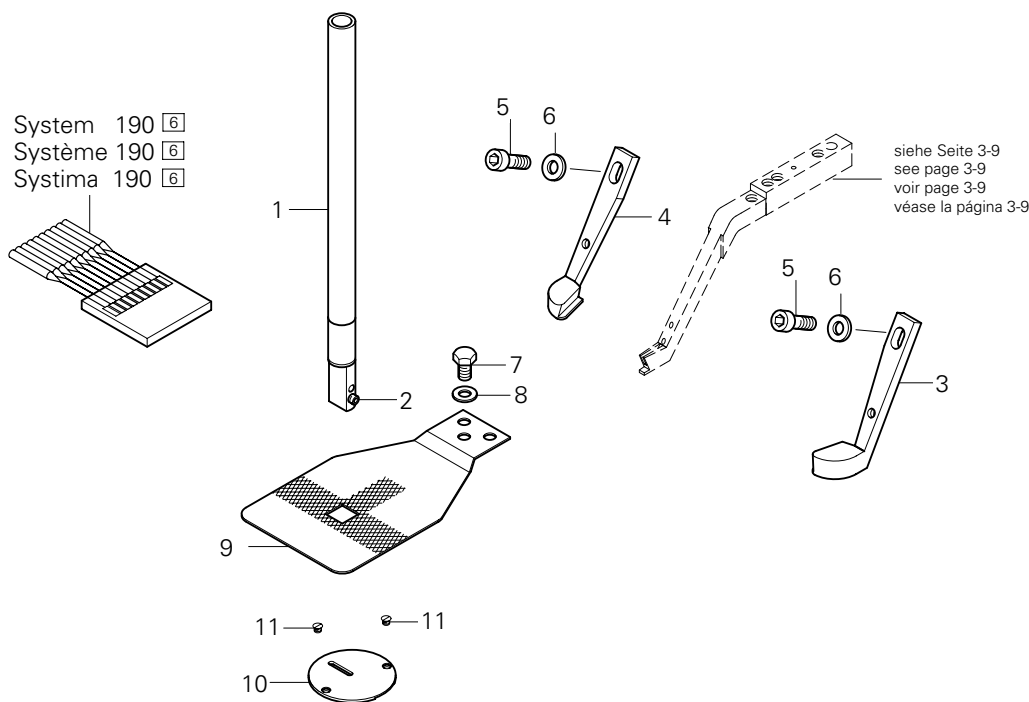

| Pos.-Nr. Item No. N° pos. N° de pos. | Stichlochdurchmesser in mm Needle hole diameter in mm Diamètre du trou d'aiguille en mm Diámetro del agujero pasante para la aguja en mm. | Nähfeldgröße Size of sewing area Dimensions du champ de couture Tamaño del campo de costura | Teile-Nr. Part No. N° de pièces N° de pieza |
|---|--|--|--|
| 1 - 2 | | | 91-021 846-91 |
| 2 | | | 11-330 082-15 |
| 3 - 8 | | | 91-232 291-90 |
| 3 | | | 91-232 292-15 |
| 4 | | | 91-232 293-15 |
| 5 | | | 11-130 173-15 |
| 6 | | | 12-305 114-15 |
| 7 | | | 91-700 770-15 |
| 8 | | | 12-305 114-15 |

| Pos.-Nr. Item No. N° pos. N° de pos. | Stichlochdurchmesser in mm Needle hole diameter in mm Diamètre du trou d'aiguille en mm Diámetro del agujero pasante para la aguja en mm. | Nähfeldgröße Size of sewing area Dimensions du champ de couture Tamaño del campo de costura | Teile-Nr. Part No. N° de pièces N° de pieza |
|---|--|--|--|
| 9 | | 7 x 7 8 x 9 5 x 5 6 x 6 8 x 8 8 x 12 | 91-232 725-24/001 91-232 725-24/002 91-232 725-24/003 91-232 725-24/004 91-232 725-24/005 91-232 725-24/006 |
| 10 | 2,0 | | 91-232 674-24/005 |
| 11 | | | 91-000 250-15 |

-1/11

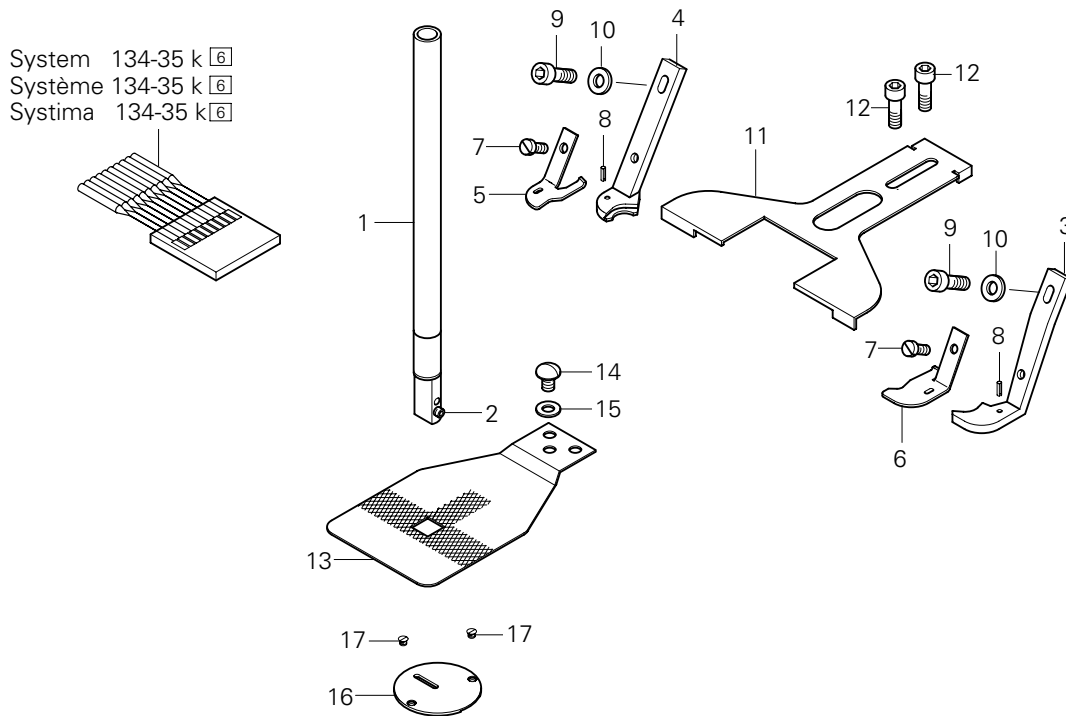

| Pos.-Nr. Item No. N° pos. N° de pos. | Stichlochdurchmesser in mm Needle hole diameter in mm Diamètre du trou d'aiguille en mm Diámetro del agujero pasante para la aguja en mm. | Nähfeldgröße Size of sewing area Dimensions du champ de couture Tamaño del campo de costura | Teile-Nr. Part No. N° de pièces N° de pieza |
|---|--|--|--|
| 1 - 2 | | | 91-132 644-91 |
| 2 | | | 11-330 082-15 |
| 3 - 8 | | | 91-232 835-90 |
| 3 | | | 91-232 836-15 |
| 4 | | | 91-232 837-15 |
| 5 | | | 91-232 839-15 |
| 6 | | | 91-232 838-15 |
| 7 | | | 11-108 087-15 |
| 8 | | | 13-033 049-05 |
| 9 | | | 11-130 173-15 |
| 10 | | | 12-305 114-15 |
| 11 | | | 91-232 827-25 |
| 12 | | | 11-130 176-25 |
| 13 | | 7 x 7 8 x 9 5 x 5 6 x 6 8 x 8 8 x 12 | 91-232 725-24/001 91-232 725-24/002 91-232 725-24/003 91-232 725-24/004 91-232 725-24/005 91-232 725-24/006 |
| 14 | | | 91-700 770-15 |
| 15 | | | 12-305 114-15 |
| 16 | 1,2 1,4 1,6 | | 91-232 674-24/001 91-232 674-24/002 91-232 674-24/003 |
| 17 | | | 91-000 250-15 |



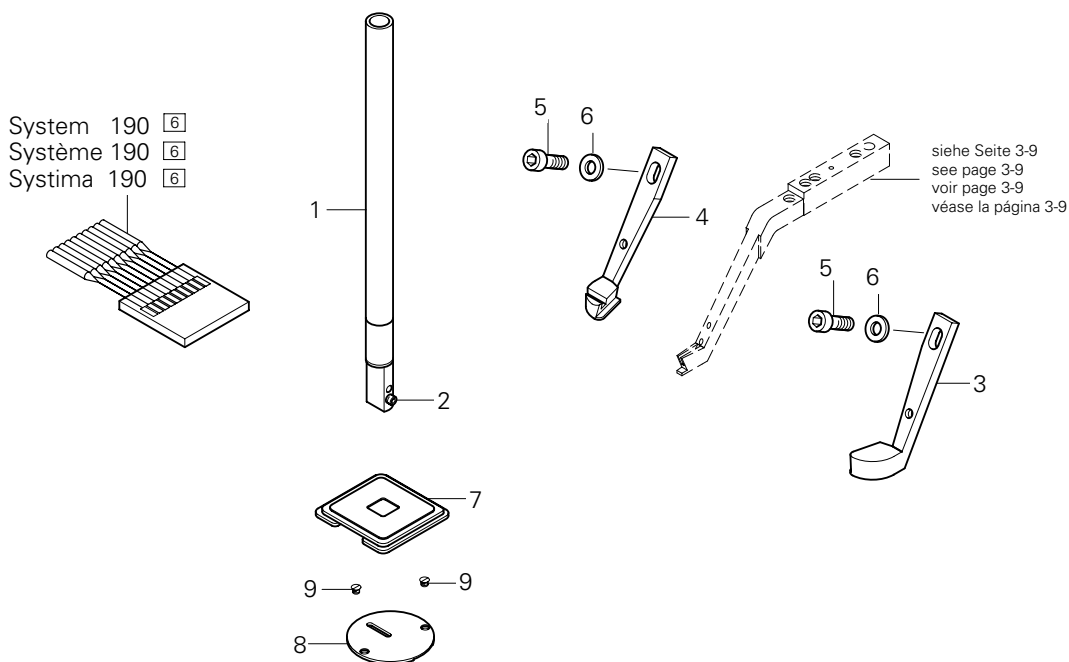

| Pos.-Nr. Item No. N° pos. N° de pos. | Stichlochdurchmesser in mm Needle hole diameter in mm Diamètre du trou d'aiguille en mm Diámetro del agujero pasante para la aguja en mm. | Nähfeldgröße Size of sewing area Dimensions du champ de couture Tamaño del campo de costura | Teile-Nr. Part No. N° de pièces N° de pieza |
|---|--|--|--|
| 1 - 2 | | | 91-021 845-91 |
| 2 | | | 11-330 082-15 |
| 3 - 4 | | | 91-232 760-10 |
| 3 | | | 91-232 292-15 |
| 4 | | | 91-232 759-15 |
| 5 | | | 11-130 173-15 |

| Pos.-Nr. Item No. N° pos. N° de pos. | Stichlochdurchmesser in mm Needle hole diameter in mm Diamètre du trou d'aiguille en mm Diámetro del agujero pasante para la aguja en mm. | Nähfeldgröße Size of sewing area Dimensions du champ de couture Tamaño del campo de costura | Teile-Nr. Part No. N° de pièces N° de pieza |
|---|--|--|---|
| 6 | | | 12-305 114-15 |
| 7 | | | 91-232 968-93/001 |
| 8 | 1,2 1,4 1,6 | | 91-232 674-24/001 91-232 674-24/002 91-232 674-24/003 |
| 9 | | | 91-000 250-15 |

-4/01

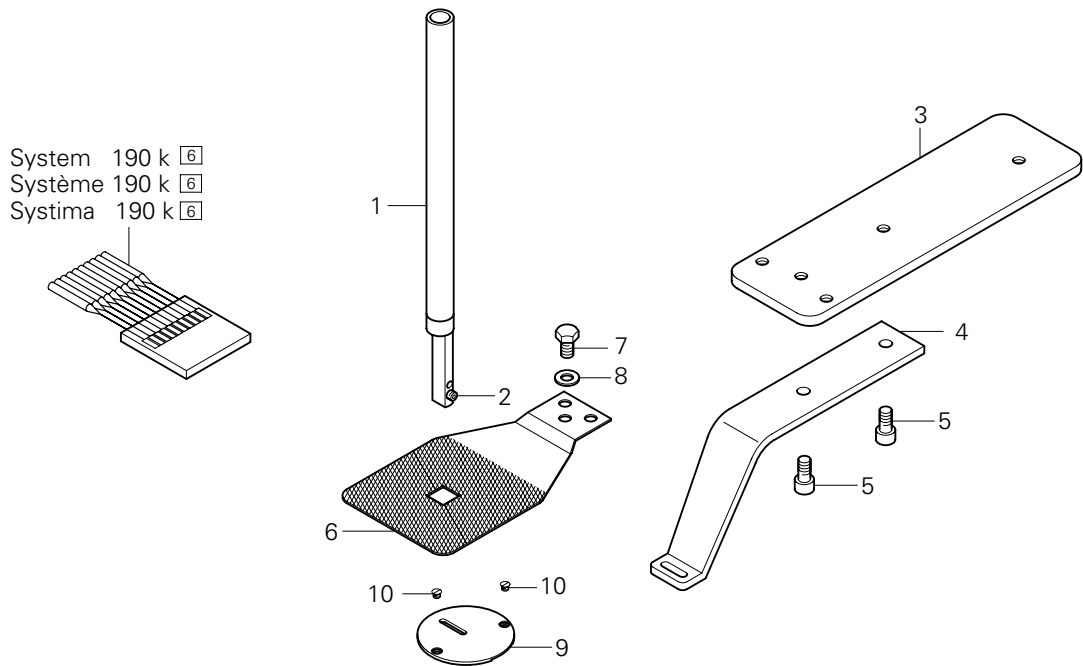

| Pos.-Nr. Item No. N° pos. N° de pos. | Stichlochdurchmesser in mm Needle hole diameter in mm Diamètre du trou d'aiguille en mm Diámetro del agujero pasante para la aguja en mm. | Nähfeldgröße Size of sewing area Dimensions du champ de couture Tamaño del campo de costura | Teile-Nr. Part No. N° de pièces N° de pieza |
|---|--|--|--|
| 1 - 2 | | | 91-132 644-91 |
| 2 | | | 11-330 082-15 |
| 3 - 5 | | | 91-232 718-11 |
| 3 | | | 91-232 715-15 |
| 4 | | | 91-232 302-15 |
| 5 | | | 11-130 173-15 |
| Pos.-Nr. Item No. N° pos. N° de pos. | Stichlochdurchmesser in mm Needle hole diameter in mm Diamètre du trou d'aiguille en mm Diámetro del agujero pasante para la aguja en mm. | Nähfeldgröße Size of sewing area Dimensions du champ de couture Tamaño del campo de costura | Teile-Nr. Part No. N° de pièces N° de pieza |
| 6 | | 7 x 7 8 x 9 5 x 5 6 x 6 8 x 8 8 x 12 | 91-232 725-24/001 91-232 725-24/002 91-232 725-24/003 91-232 725-24/004 91-232 725-24/005 91-232 725-24/006 |
| 7 | | | 91-700 770-15 |
| 8 | | | 12-305 114-15 |
| 9 | 1,2 1,4 1,6 | | 91-232 674-24/001 91-232 674-24/002 91-232 674-24/003 |
| 10 | | | 91-000 250-15 |



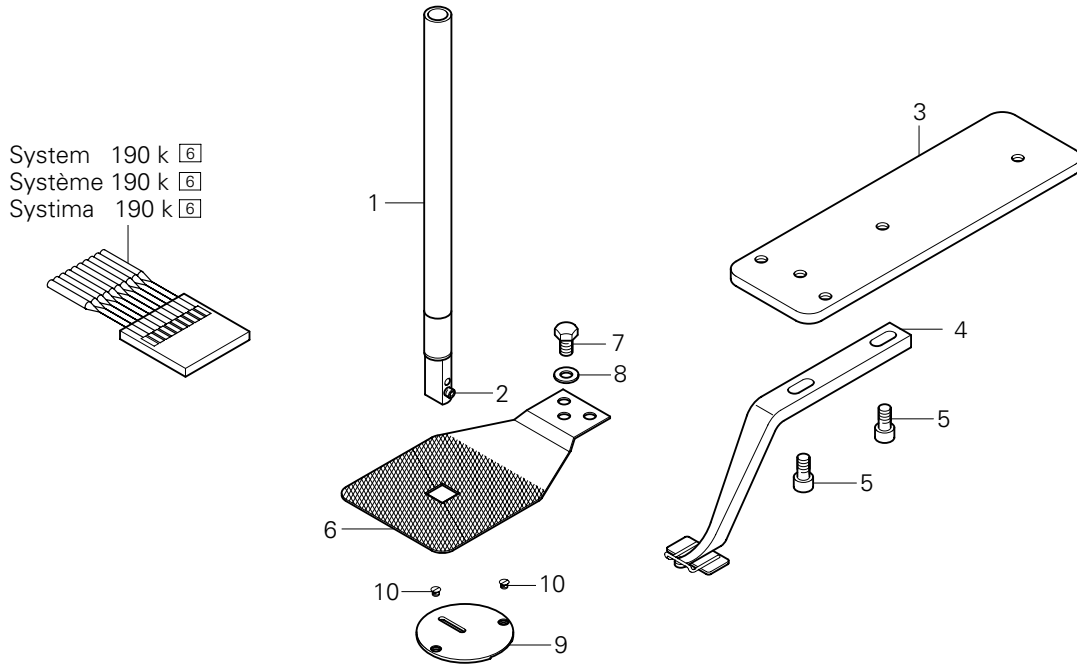

| Pos.-Nr. Item No. N° pos. N° de pos. | Stichlochdurchmesser in mm Needle hole diameter in mm Diamètre du trou d'aiguille en mm Diámetro del agujero pasante para la aguja en mm. | Nähfeldgröße Size of sewing area Dimensions du champ de couture Tamaño del campo de costura | Teile-Nr. Part No. N° de pièces N° de pieza |
|---|--|--|--|
| 1 - 2 | | | 91-021 845-91 |
| 2 | | | 11-330 082-15 |
| 3 - 5 | | | 91-233 021-11 |
| 3 | | | 91-232 715-15 |
| 4 | | | 91-233 022-11 |
| 5 | | | 11-130 176-15 |

| Pos.-Nr. Item No. N° pos. N° de pos. | Stichlochdurchmesser in mm Needle hole diameter in mm Diamètre du trou d'aiguille en mm Diámetro del agujero pasante para la aguja en mm. | Nähfeldgröße Size of sewing area Dimensions du champ de couture Tamaño del campo de costura | Teile-Nr. Part No. N° de pièces N° de pieza |
|---|--|--|--|
| 6 | | 7 x 7 8 x 9 5 x 5 6 x 6 8 x 8 8 x 12 | 91-232 725-24/001 91-232 725-24/002 91-232 725-24/003 91-232 725-24/004 91-232 725-24/005 91-232 725-24/006 |
| 7 | | | 91-700 770-15 |
| 8 | | | 12-305 114-15 |
| 9 | 1,2 1,4 1,6 | | 91-232 674-24/001 91-232 674-24/002 91-232 674-24/003 |
| 10 | | | 91-000 250-15 |



-4/03

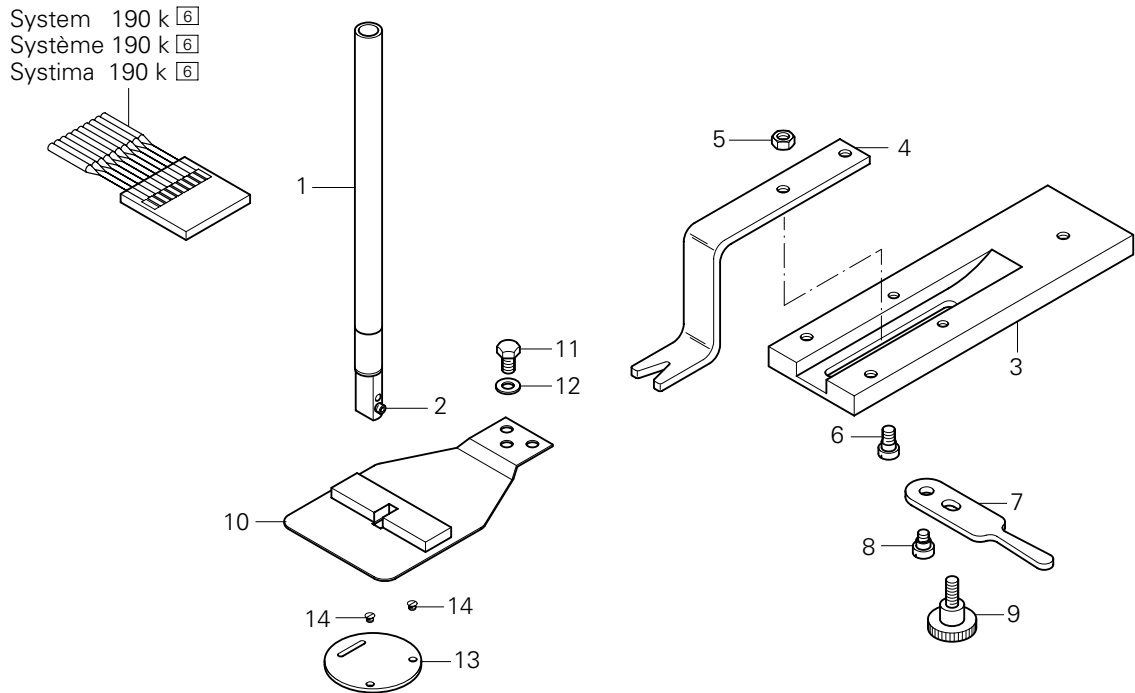

| Pos.-Nr. Item No. N° pos. N° de pos. | Stichlochdurchmesser in mm Needle hole diameter in mm Diamètre du trou d'aiguille en mm Diámetro del agujero pasante para la aguja en mm. | Nähfeldgröße Size of sewing area Dimensions du champ de couture Tamaño del campo de costura | Teile-Nr. Part No. N° de pièces N° de pieza |
|---|--|--|---|
| 1 - 2 | | | 91-132 644-91 |
| 2 | | | 11-330 082-15 |
| 3 - 9 | | | 91-233 091-91 |
| 3 | | | 91-233 093-15 |
| 4 | | | 91-233 092-15 |
| 5 | | | 12-005 154-25 |
| 6 | | | 91-700 364-15 |
| 7 | | | 91-023 529-15 |
| 8 | | | 91-700 366-15 |
| 9 | | | 11-550 176-15 |
| 10 | | | 91-110 007-41 |
| 11 | | | 91-700 770-15 |
| 12 | | | 12-305 114-15 |
| 13 | 1,2 1,4 1,6 | | 91-232 674-24/001 91-232 674-24/002 91-232 674-24/003 |
| 14 | | | 91-000 250-15 |



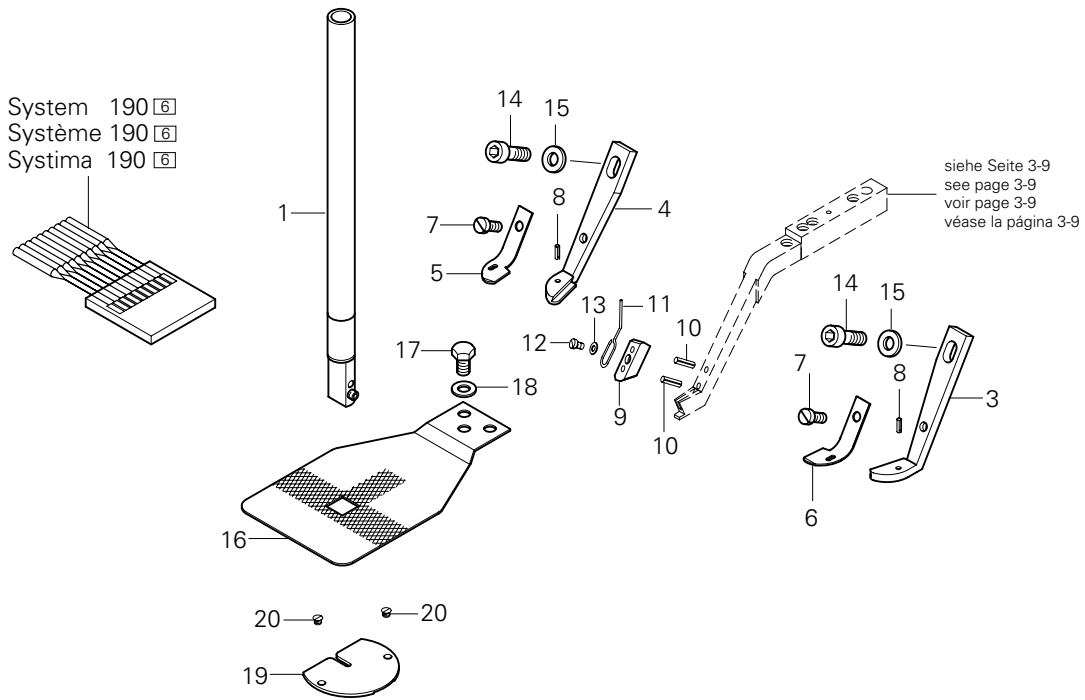

-5/01



| Pos.-Nr. Item No. N° pos. N° de pos. | Stichlochdurchmesser in mm Needle hole diameter in mm Diamètre du trou d'aiguille en mm Diámetro del agujero pasante para la aguja en mm. | Nähfeldgröße Size of sewing area Dimensions du champ de couture Tamaño del campo de costura | Teile-Nr. Part No. N° de piezas N° de pieza |
|---|--|--|--|
| 1 - 2 | | | 91-021 846-91 |
| 2 | | | 11-330 082-15 |
| 3 - 8 | | | 91-232 288-90 |
| 3 | | | 91-232 289-15 |
| 4 | | | 91-232 290-15 |
| 5 | | | 91-132 640-15 |
| 6 | | | 91-132 642-15 |
| 7 | | | 11-108 087-15 |
| 8 | | | 13-033 049-05 |
| 9 | | | 91-232 767-15 |
| 10 | | | 13-052 055-55 |
| 11 | | | 91-232 766-05 |
| 12 | | | 11-172 085-25 |

| Pos.-Nr. Item No. N° pos. N° de pos. | Stichlochdurchmesser in mm Needle hole diameter in mm Diamètre du trou d'aiguille en mm Diámetro del agujero pasante para la aguja en mm. | Nähfeldgröße Size of sewing area Dimensions du champ de couture Tamaño del campo de costura | Teile-Nr. Part No. N° de piezas N° de pieza |
|---|--|--|--|
| 13 | | | 12-305 084-25 |
| 14 | | | 11-130 173-15 |
| 15 | | | 12-305 114-15 |
| 16 | | 7 x 7 8 x 9 5 x 5 6 x 6 8 x 8 8 x 12 | 91-232 725-24/001 91-232 725-24/002 91-232 725-24/003 91-232 725-24/004 91-232 725-24/005 91-232 725-24/006 |
| 17 | | | 91-700 770-15 |
| 18 | | | 12-305 114-15 |
| 19 | 2,2 | | 91-232 675-24/006 |
| 20 | | | 91-000 250-15 |

-9/01

System 332 LG HK SP 
Système 332 LG HK SP 
Systema 332 LG HK SP 

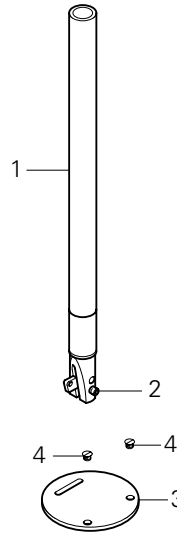
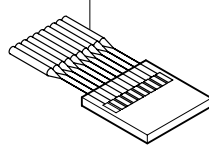

| Pos.-Nr. Item No. N° pos. N° de pos. | Stichlochdurchmesser in mm Needle hole diameter in mm Diamètre du trou d'aiguille en mm Diámetro del agujero pasante para la aguja en mm. | Nähfeldgröße Size of sewing area Dimensions du champ de couture Tamaño del campo de costura | Teile-Nr. Part No. N° de piezas N° de pieza |
|---|--|--|--|
| 1 - 2 | | | 91-110 247-92 |
| 2 | | | 11-330 082-15 |
| Pos.-Nr. Item No. N° pos. N° de pos. | Stichlochdurchmesser in mm Needle hole diameter in mm Diamètre du trou d'aiguille en mm Diámetro del agujero pasante para la aguja en mm. | Nähfeldgröße Size of sewing area Dimensions du champ de couture Tamaño del campo de costura | Teile-Nr. Part No. N° de piezas N° de pieza |
| 3 | 2,0 | | 91-232 677-24/001 |
| 4 | | | 91-000 250-15 |



PFAFF

PFAFF Industrie Maschinen AG

Postfach 3020
D-67653 Kaiserslautern

Königstr. 154
D-67655 Kaiserslautern

Telefon: (0631) 200-0
Telefax: (0631) 17202
E-Mail: info@pfaff-industrial.com

Gedruckt in der BRD
Printed in Germany
Imprimé en R.F.A.
Impreso en la R.F.A.