

## 1425

## 1426

Teilleiste

Parts list

Liste de pièces

Lista de piezas

## 3715

-2/01

-2/02

Diese Teileliste hat für Maschinen ab nachfolgender  
Seriennummer Gültigkeit:

This parts list applies to machines from the following  
serial numbers onwards:

Cette liste de pièces est valable pour les machines au  
numéros de série à partir de:

Esta lista de piezas tiene validez para máquinas a partir del  
número de serie siguiente:

# 2572934



Alle Informationen und Abbildungen waren zum Zeitpunkt der Druckgebung auf dem neusten Stand.

Technische Änderungen vorbehalten!

Der Nachdruck, die Vervielfältigung sowie die Übersetzung - auch auszugsweise - aus PFAFF-Teilelisten ist nur mit unserer vorherigen Zustimmung und mit der Quellenangabe gestattet.

At the time of printing, all information and illustrations contained in this document were up to date.

Subject to alteration!

The reprinting, copying or translation of PFAFF Parts lists whether in whole or in part, is only permitted with our previous permission and with written reference to the source.

Au moment de la remise à l'imprimeur, toutes les informations et figures se rapportant à cette machine correspondaient à l'état actuel des connaissances.

Sous réserve de modifications techniques!

Aucune reproduction, polycopie ou traduction - même par extraits - des listes de pièces PFAFF ne peut être effectuée, à condition d'en indiquer l'origine, sans notre autorisation expresse.

Todas las informaciones e ilustraciones de este manual estaban al día en el momento de entregarse para su impresión.

¡ Salvo modificaciones técnicas!

La reimpresión, reproducción y traducción - aunque sólo sea parcial - de las listas de piezas PFAFF sólo está permitida con nuestro permiso previo e indicando la fuente.

**G.M. PFAFF KAISERSLAUTERN  
INDUSTRIEMASCHINEN AG**

Postfach 3020  
D-67653 Kaiserslautern

Königstr. 154  
D-67655 Kaiserslautern

Redaktion/Illustration  
Verlag Technische Dokumentation  
Postfach 1106  
D-77901 Lahr

|      |  | Seite<br>Page<br>Page<br>Página |
|------|--|---------------------------------|
| 0    | Wichtiger Hinweis .....<br>Important note<br>Avis important<br>Observación importante  | 0 - 1                           |
| 1    | Vorwort .....<br>Foreword<br>Avant-propos<br>Notas preliminares  | 1 - 1                           |
| 2    | Erläuterungen der Schlüsselzeichen .....<br>Explanation of key markings<br>Explication des symboles<br>Explicaciones de los signos clave | 2 - 1                           |
| 3    | Basismaschine<br>Basic machine<br>Machine de base<br>Máquina básicas   |                                 |
| 3.01 | Gehäuseteile .....<br>Housing sections<br>Parties du corps<br>Piezas del cárter  | 3 - 1                           |
| 3.02 | Kopfteile .....<br>Needle head parts<br>Pièces de tête<br>Piezas de la cabeza  | 3 - 2                           |
| 3.03 | Armteile .....<br>Arm parts<br>Pièces de bras<br>Piezas del brazo  | 3 - 9                           |
| 3.04 | Grundplattenteile .....<br>Bedplate parts<br>Pièces du plateau fondamental<br>Piezas del cárter  | 3 - 14                          |
| 4    | Kanten-Beschneideeinrichtung (-731/02) .....<br>Edge trimmer (-731/02)<br>Couteau (-731/02)<br>Recortador (-731/02)                      | 4 - 1                           |

|       |  | Seite<br>Page<br>Page<br>Página |
|-------|--|---------------------------------|
| 5     | Presserfuß-Automatik (-910/04) .....<br>Automatic presser foot lifter (-910/04)<br>Relève-pied automatique (-910/04)<br>Grupo acondicionador del aire comprimido (-910/04) | 5 - 1                           |
| 6     | Verriegelungs-Einrichtung (-911/35) .....<br>Backtacking mechanism (-911/35)<br>Dispositif à points d'arrêt (-911/35)<br>Rematador (-911/35)                               | 6 - 1                           |
| 7     | Schalteinrichtung (-918/29) .....<br>Switching system (-918/29)<br>Dispositif de commande (-918/29)<br>Mecanismo de mando (-918/29)  | 7 - 1                           |
| 8     | Wartungseinheit (-925/03) .....<br>Air filter / lubricator (-925/03)<br>Conditionneur d'air comprimé (-925/03)<br>Grupo acondicionador del aire comprimido (-925/03)       | 8 - 1                           |
| 9     | Spulenfadenvorratswächter (-926/06) .....<br>Bobbin thread supply monitor (-926/06)<br>Contrôleur de canette (-926/06)<br>Detector del hilo de la canilla (-926/06)        | 9 - 1                           |
| 10    | Pneumatische Ausrüstung .....<br>Pneumatic equipment<br>Equipement pneumatique<br>Equipo neumático   | 10 - 1                          |
| 11    | Elektrische Ausrüstung<br>Electrical equipment<br>Equipement électrique<br>Equipo eléctrico  |                                 |
| 11.01 | Kabelbaum zum Oberteil .....<br>Cable tree to sewing head<br>Faisceau de câbles vers la tête de machine<br>Mazo de cables para el cabezal                                  | 11 - 1                          |
| 11.02 | Tastschalter .....<br>Push-button<br>Interrupteur à bouton-poussoir<br>Interruptor pulsador  | 11 - 2                          |

|  | Seite<br>Page<br>Page<br>Página |
|--|---------------------------------|
| 11.03 Bedienfeld .....<br>Control panel<br>Panneau de commande<br>Panel de mandos  | 11 - 3                          |
| 11.04 Positionsgeber .....<br>Synchronizer<br>Synchronisateur<br>Sincronizador   | 11 - 4                          |
| 11.05 Sollwertgeber .....<br>Set-point generator<br>Codeur<br>Emisor del valor teórico   | 11 - 4                          |
| 11.06 Motordreh­schalter .....<br>Motor turn switch<br>Interrupteur rotatif<br>Interruptor giratorio   | 11 - 5                          |
| 11.07 Knieschalter mit Leitung .....<br>Knee switch with cable<br>Interrupteur de genouillère avec câble<br>Interruptor de rodillera con cable | 11 - 5                          |
| 11.08 Steuergerät .....<br>Control device<br>Boîte de commande<br>Caja de mandos   | 11 - 6                          |
| 12 Garnrollen­ständer .....<br>Reel stands<br>Porte-bobines<br>Portacarretes   | 12 - 1                          |
| 13 Einstellehren .....<br>Adjustment gauges<br>Calibres<br>Calibres de ajuste  | 13 - 1                          |
| 14 Teile zur Tischplatte .....<br>Parts for table top<br>Pièces du plateau<br>Piezas para el tablero   | 13 - 1                          |

|       |   | Seite<br>Page<br>Page<br>Página |
|-------|---|---------------------------------|
| 15    | Keilriemen .....<br>V-belt<br>Courroie trapézoïdale<br>Correa trapezoidal   | 15 - 1                          |
| 16    | Teile zum Doku-Naht-System .....<br>Parts for the docu-seam system<br>Pièces du système de couture Doku<br>Piezas para el sistema de costura Doku                       | 16 - 1                          |
| 17    | Schmiermittel-Übersicht .....<br>Overview of lubricants<br>Tableau de lubrifiants<br>Tabla de lubricantes   | 17 - 1                          |
| 18    | Index (Teilenummern / Seitenzahlen) .....<br>Index (part numbers / page numbers)<br>Index (numéros de pièces, de pages)<br>Index (números de pieza / números de página) | 18 - 1                          |
| 19    | Unterklassen-Ausstattung<br>Subclass parts<br>Composition des sous-classes<br>Composición de las subclases  |                                 |
| 19.01 | Nähwerkzeuge (PFAFF 1425;3715) .....<br>Gauge parts (PFAFF 1425;3715)<br>Organes de couture (PFAFF 1425;3715)<br>Organos de costura (PFAFF 1425;3715)                   | 19 - 2                          |
| 19.02 | Nähwerkzeuge (PFAFF 1426) .....<br>Gauge parts (PFAFF 1426)<br>Organes de couture (PFAFF 1426)<br>Organos de costura (PFAFF 1426)                                       | 19 - 24                         |

### Achtung!



Wir machen ausdrücklich darauf aufmerksam, daß Ersatz- und Zubehörteile, die nicht von uns geliefert werden, auch nicht von uns geprüft und freigegeben sind. Der Einbau und / oder die Verwendung solcher Produkte kann daher u. Umständen konstruktiv vorgegebene Eigenschaften Ihrer Maschine negativ verändern. Für Schäden, die durch die Verwendung von Nicht-Originalteilen entstehen, übernehmen wir keine Haftung!

### Caution!



We warn you expressively that spare parts and accessories that are not supplied by us are not tested and released by us. Fitting or using these products may therefore have negative influences on features that depend on the machine design. We are not liable for any damage caused by the use of non-Pfaff parts!

### Attention!



Nous attirons expressément votre attention sur le fait que les pièces de rechange et accessoires qui n'ont pas été livrés par nous n'ont pas non plus été contrôlés et agréés par nous. C'est pourquoi le montage et/ou l'utilisation de telles pièces peut éventuellement entraîner l'altération des caractéristiques de construction de votre machine. Par conséquent, nous n'assumons aucune responsabilité pour les dommages causés par l'emploi de pièces qui ne sont pas d'origine!

### ¡Atención!



Se hace observar que en el caso de piezas de recambio y accesorios que no hayan sido suministrados por nosotros, quiere decir que non han sido sometidas por nuestra parte a un control y que no se les ha dado el visto bueno. Por esta razón, el montaje y/o empleo de tales productos puede repercutir negativamente en las características previstas en su máquina. ¡Para los daños que eventualmente pudiesen presentarse al utilizar piezas no originales, no asumimos ninguna garantía!

- Die Seriennummer der Maschine, für die diese Teileliste Gültigkeit hat, ist auf der Titelseite aufgeführt.
  - Alle Teile sind so abgebildet, wie sie in der Maschine funktionsmäßig zusammengehören.
  - Gestrichelt dargestellte Teile zeigen angrenzende Teile aus anderen Funktionsgruppen.
  - Im oberen Teil der Bildseiten befindet sich eine Gesamtansicht der Maschine .
  - Der Einbauort der dargestellten Teile wird durch eine gerasterte Fläche gekennzeichnet.
  - Einrahmungen auf den Bildseiten zeigen, aus welchen Einzelteilen sich die Gruppenteile zusammensetzen.
  - Die auf den Bildseiten verwendeten Schlüsselzeichen (  ;  2 ;  3 usw.) sind im Kapitel "Erläuterungen der Schlüsselzeichen" aufgelistet.
- 
- The serial number of the machine to which this parts list applies is indicated on the cover page.
  - All parts are illustrated in function groups with the parts which they function together with in the machine.
  - Parts illustrated with broken lines are parts from other function groups which border on the illustrated function group.
  - The above section of the page of illustrations contains a total view of the machine. The place for the installation of the parts pictured here is marked by the grid.
  - The framed-in sections on the illustration pages show the individual parts comprising a group.
  - The key markings used on the illustrated pages (  ;  2 ;  3 etc.) are listed in the chapter "Explanation of key markings".
- 
- Le numéro de série de la machine pour laquelle cette liste de pièces est valable est indiqué sur la première page.
  - Toutes les pièces sont représentées en fonction de leur groupement fonctionnel dans la machine.
  - Les pièces hâchurées indiquent les pièces limitrophes de groupes de fonctions différents.
  - La partie supérieure des pages de figures comprend une présentation globale de la machine. L'emplacement des pièces représentées est signalé par quadrillages.
  - Les parties encadrées sur les pages à illustrations représentent les pièces individuelles formant groupe.
  - Vous trouverez au chapitre "Explication des symboles" une liste des symboles utilisés sur les pages de figures (  ;  2 ;  3 etc.)
- 
- El número de serie de la máquina para la cual tiene validez esta lista de piezas va indicado en la página de título.
  - Todas las piezas están ilustradas tal como aparecen en la máquina para su funcionamiento.
  - Las piezas representadas con rayitas muestran piezas colindantes de otros grupos de funciones.
  - En la parte superior de las páginas ilustradas se puede ver una vista en conjunto de la máquina.
  - El lugar de montaje de la pieza representada va caracterizada mediante una superficie reticulada.
  - Los recuadros en las páginas ilustradas indican las piezas individuales de que se componen los grupos.
  - Los signos clave (  ;  2 ;  3 etc.) empleados en las páginas con ilustraciones van listados en el capítulo "Explicaciones de los signos clave".



- |     |  |
|-----|--|
|     | Unterklassenabhängig, Teilenummer siehe Unterklassen-Ausstattung.<br>Subclas-dependent, for part number see subclass parts listing.<br>Fonction de la sous-classe; pour le numéro de la pièce, voir "Equipement de sous-classes".<br>Dependientes de la subclase, para el número de pieza véase "Dotación de subclases". |
| B   | Maschinen-Ausstattung für mittlere Materialien.<br>Model B for sewing thin and medium-weight materials.<br>Modèle B pour la couture de matières moyennes.<br>Tipo B para materiales semiligeros.   |
| C   | Maschinen-Ausstattung für mittelschwere Materialien.<br>Model C for sewing medium-heavy materials.<br>Modèle C pour la couture de matières mi-lourdes.<br>Tipo C para materiales semipesados.  |
| C/D | Maschinen-Ausstattung wie C; jedoch mit größerem Stichloch ( 2,6 mm).<br>Machine equipped as model C, but with larger needle hole ( 2.6 mm).<br>Machine prévue comme en C, mais avec trou d'aiguille plus grand ( 2,6 mm).<br>Tipo de máquina como C, pero con agujero de la placa de aguja má grande ( 2,6 mm).         |
| N   | Stichlänge 6,0 mm.<br>Stitch length 6.0 mm.<br>Longeur du point 6,0 mm.<br>Largo de puntada 6,0 mm.  |
| N8  | Stichlänge 8,0 mm.<br>Stitch length 8.0 mm.<br>Longeur du point 8,0 mm.<br>Largo de puntada 8,0 mm.  |
| 3/1 | Gesichert mit Loctite<br>Secured with Loctite<br>Bloqué par Loctite<br>Asegurado con loctite   |
| 3/4 | Selbstklebend<br>Self-adhesive<br>Auto-adhésive<br>Autoadhesivo  |
| 6   | Nadeldicke und Spitzenform bei Bestellung angeben.<br>Needle size and style of point to be stated on order.<br>Préciser la grosseur de l'aiguille et la forme de la pointe à la commande.<br>Grosor de aguja y forma de la punta, indíquese en los pedidos.  |

- 27/2      Eingeklammerte Zahl = Dicke in mm.  
            Number in brackets = thickness in mm.  
            Chiffre entre parenthèses = épaisseur en mm.  
            Cifra entre paréntesis = espesor en mm.
- 28/1      Sonderausführung mit Spulenkapsel  
            Special model with bobbin case  
            Version spéciale avec boîte à canette  
            Modelo especial con caja de bobina
- 32/1      Beim Einbau dieses Teiles ist Nacharbeit erforderlich.  
            When fitting this part re-work is required.  
            Retouches nécessaires au montage.  
            Al montar esta pieza hay que retocarla antes.
- 40/2      Tränken mit 28-011 201-44; Bestellnummer siehe Seite 17 - 1.  
            Soak with 28-011 201-44; for part number see page 17 - 1.  
            Imbiber d`huile 28-011 201-44; n° de commande, voir page 17 - 1.  
            Empage con aceite 28-011 201-44; para el número de pedido véase la página 17 - 1.
- 40/3      Fetten mit 28-011 202-47; Bestellnummer siehe Seite 17 - 1.  
            Grease with 28-011 202-47; for part number see page 17 - 1.  
            Graisser avec de la graisse 28-011 202-47; n° de commande, voir page 17 - 1.  
            Engrase con grasa 28-011 202-47; para el número de pedido véase la página 17 - 1.
- 40/4      Fetten mit 28-011 202-43; Bestellnummer siehe Seite 17 - 1.  
            Grease with 28-011 202-43; for part number see page 17 - 1.  
            Graisser avec de la graisse 28-011 202-43; n° de commande, voir page 17 - 1.  
            Engrase con grasa 28-011 202-43; para el número de pedido véase la página 17 - 1.
- 40/5      Ölen mit 28-011 201-44; Bestellnummer siehe Seite 17 - 1.  
            Oil with 28-011 201-44; for part number see page 17 - 1.  
            Huiler avec de la graisse 28-011 201-44; n° de commande, voir page 17 - 1.  
            Lubrifique con grasa 28-011 201-44; para el número de pedido véase la página 17 - 1.
- 40/13     Fetten mit 28-011 202-05; Bestellnummer siehe Seite 17 - 1.  
            Grease with 28-011 202-05; for part number see page 17 - 1.  
            Graisser avec de la graisse 28-011 202-05; n° de commande, voir page 17 - 1.  
            Engrase con grasa 28-011 202-05; para el número de pedido véase la página 17 - 1.
- 60        Wahlweise  
            Optional  
            Au choix  
            Opcional

- |      |  |
|------|--|
| 81/3 | Verwendung je nach Bedarf.<br>To be used as required.<br>Utilisation en fonction des besoins.<br>Utilización según sea necesario                           |
| 90/1 | Für Wechselstrom<br>For single-phase A.C.<br>Pour du courant alternatif<br>Para corriente alterna monofásica   |
| 95/8 | X-Werte bei Bestellung angeben.<br>Please state x-values on order.<br>Indiquer les valeurs "x" à la commande.<br>Indíquese en los pedidos los valores "x". |
| 96   | Länge angeben<br>State length<br>Préciser longueur<br>Indíquese la largura   |

# 2

Erläuterung der Schlüsselzeichen  
Explanation of key markings  
Explication des symboles  
Explicaciones de los signos clave

---

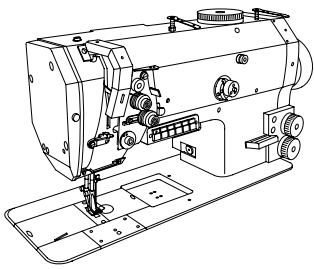

### Gehäuseteile

Housing sections

PFAFF 1425-900/81;-900/82

Parties du corps

PFAFF 1426-900/81

Piezas del cárter

PFAFF 3715-2/01;-2/02

# 3.01

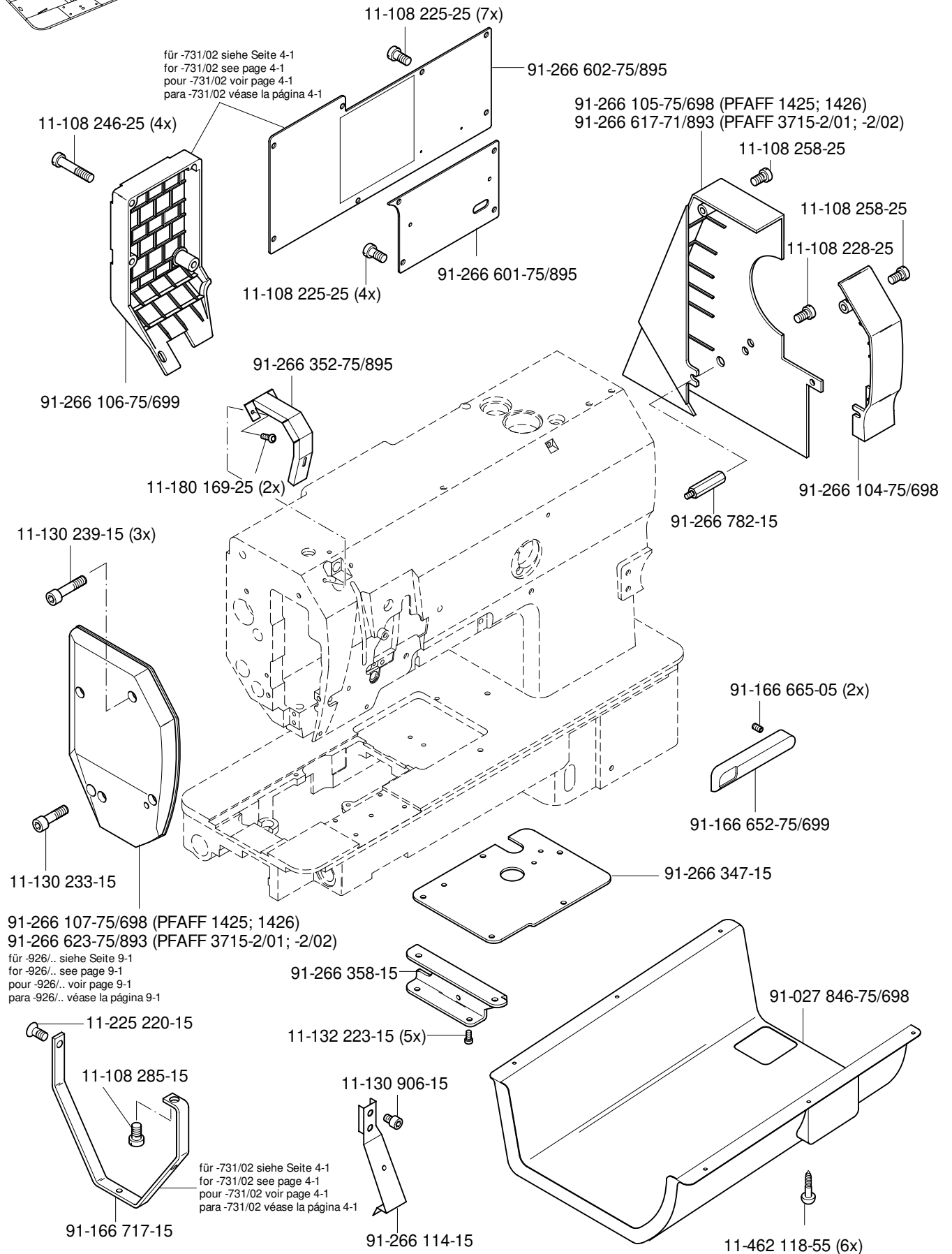

# 3.02

Kopfteile  
Needle head parts  
Pièces de tête  
Piezas de la cabeza

PFAFF 1425-900/81;-900/82  
PFAFF 1426-900/81  
PFAFF 3715-2/01;-2/02

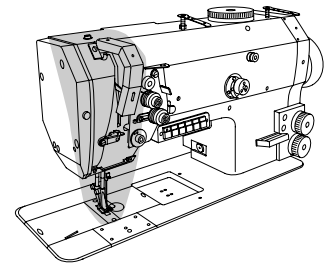

91-166 393-01  
für -731/02 siehe Seite 4-2  
for -731/02 see page 4-2  
pour -731/02 voir page 4-2  
para -731/02 véase la página 4-2

11-341 904-15 (3x)

40/3

40/3

40/3

91-266 258-91  
für -731/02 siehe Seite 4-2  
for -731/02 see page 4-2  
pour -731/02 voir page 4-2  
para -731/02 véase la página 4-2

11-130 293-15

91-166 480-92

12-610 170-45 (4x)

91-166 485-01

40/3

40/3

91-266 326-05

91-176 178-05

91-266 277-01

91-266 172-05

91-166 487-05 (2x)

91-266 173-05

91-176 192-05

91-069 062-05 (6x)

91-266 325-05 (2x)

91-166 997-01

91-166 550-15

91-177 610-05

91-177 609-05

91-171 808-05

91-176 267-05

91-140 372-05

91-266 334-05 (2x)

91-266 400-05 (2x)

für -731/02 siehe Seite 4-2  
for -731/02 see page 4-2  
pour -731/02 voir page 4-2  
para -731/02 véase la página 4-2

91-166 518-15 (2x)

11-130 089-15 (2x)

11-130 173-15 (4x)

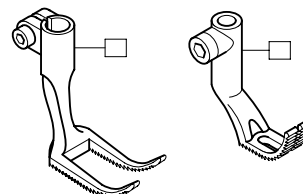

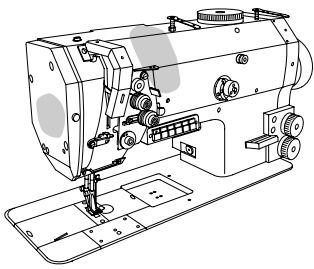

Kopfteile

Needle head parts

PFAFF 1425-900/81;-900/82

Pièces de tête

PFAFF 1426-900/81

Piezas de la cabeza

PFAFF 3715-2/01;-2/02

3.02

11-335 280-15



12-710 270-12

11-130 287-15

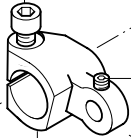

11-341 166-15

91-166 511-92

91-266 826-91

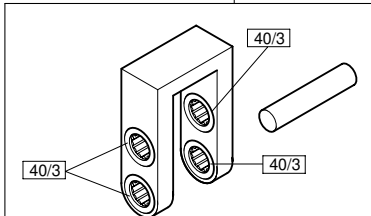

91-166 507-91

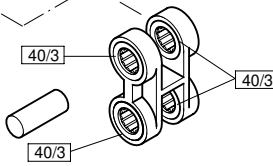

11-132 292-15

11-341 904-15

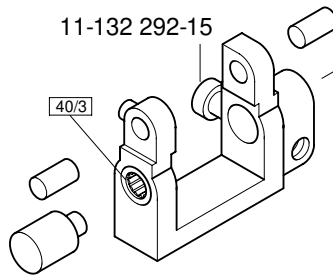

91-266 827-91

siehe Seite 3-11  
see page 3-11  
voir page 3-11  
véase la página 3-11

11-341 166-15

11-330 960-15 (2x)

15-718 051-51

91-166 510-05

11-173 174-25 (2x)

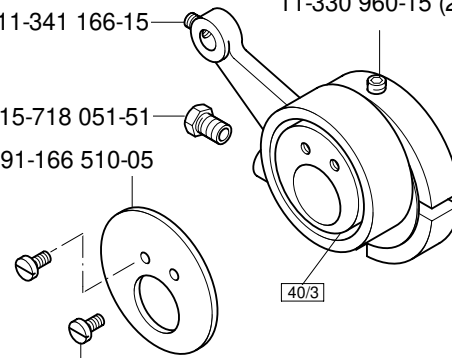

11-341 217-15

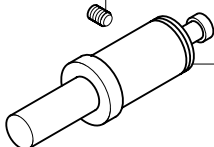

91-166 524-91

11-108 846-15

11-108 846-15

11-341 217-15

91-166 529-05

91-171 875-12

91-171 875-12



14-218 090-01 40/3

siehe Seite 3-2  
see page 3-2  
voir page 3-2  
véase la página 3-2

# 3.02

Kopfteile  
Needle head parts  
Pièces de tête  
Piezas de la cabeza

PFAFF 1425-900/81;-900/82  
PFAFF 3715-2/01;-2/02

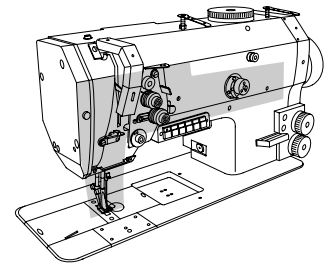

siehe Seite 3-12  
see page 3-12  
voir page 3-12  
véase la página 3-12

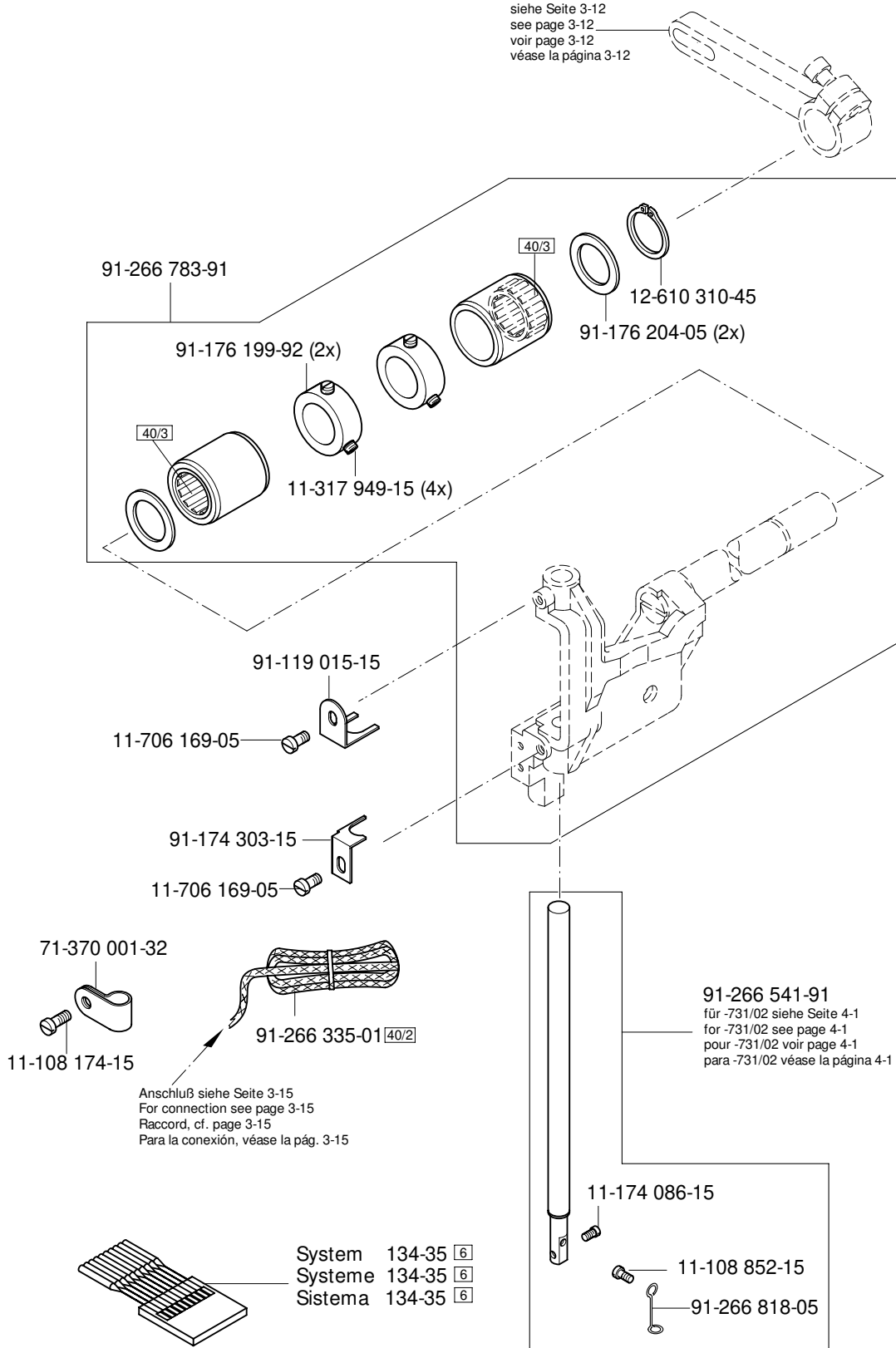



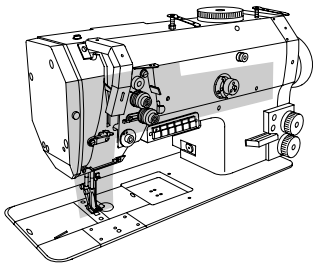

Kopfteile  
 Needle head parts  
 Pièces de tête  
 Piezas de la cabeza PFAFF 1426-900/81

3.02

siehe Seite 3-12  
 see page 3-12  
 voir page 3-12  
 véase la página 3-12

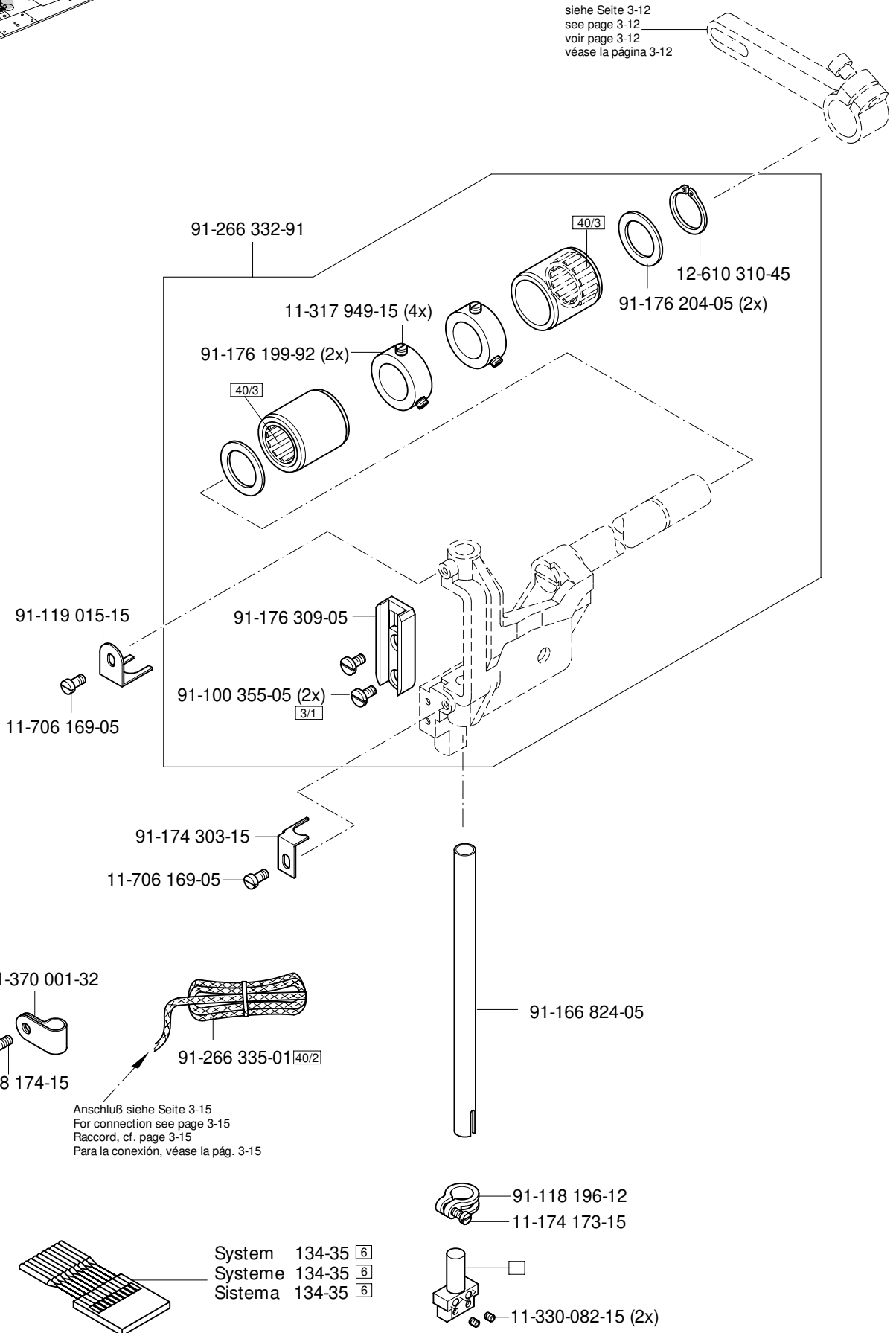

# 3.02

Kopfteile  
 Needle head parts PFAFF 1425-900/81;-900/82  
 Pièces de tête PFAFF 1426-900/81  
 Piezas de la cabeza PFAFF 3715-2/01;-2/02

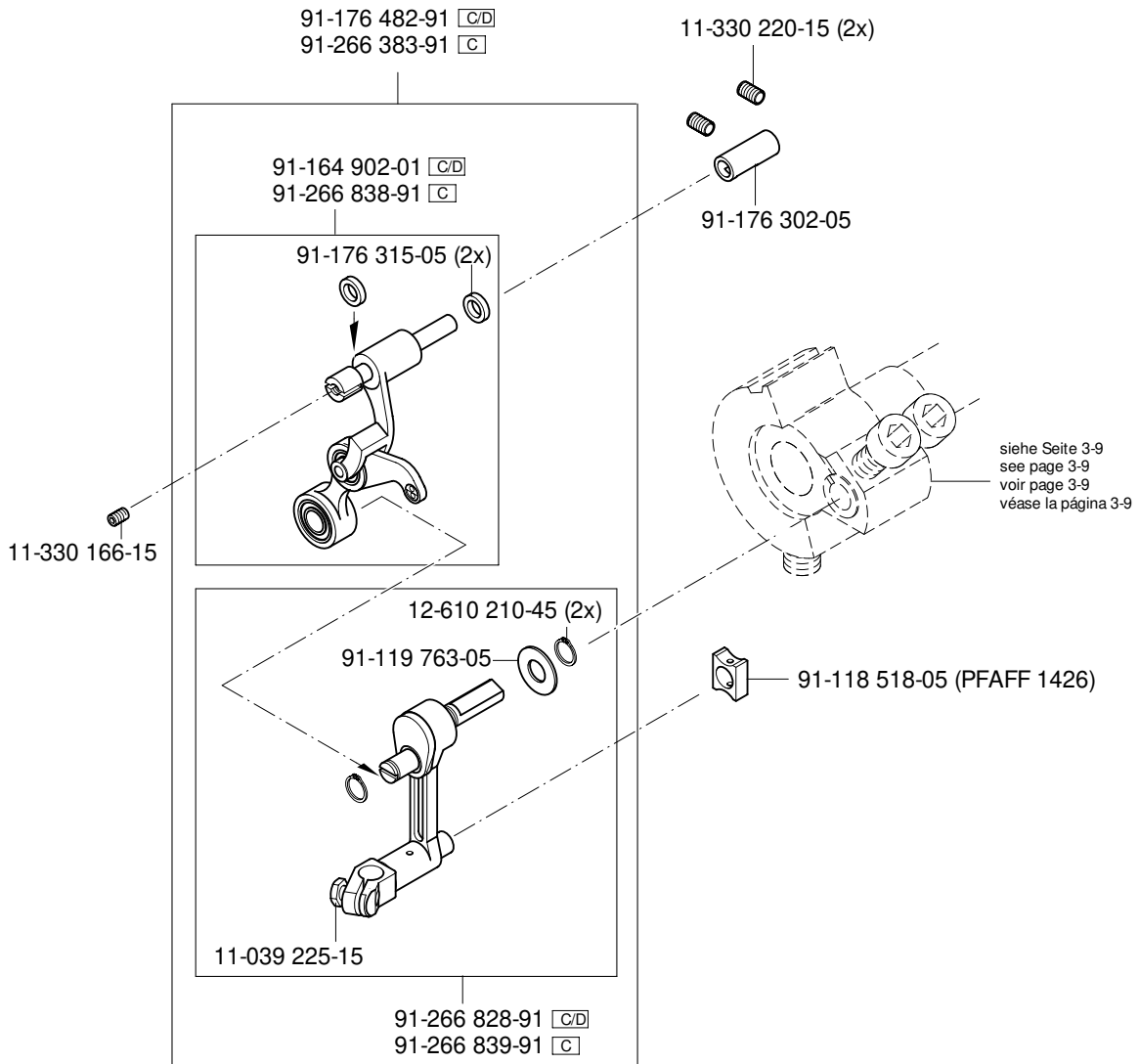
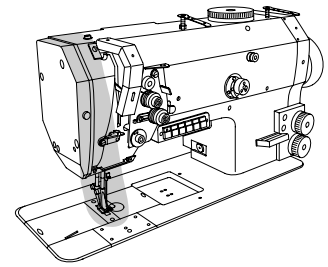

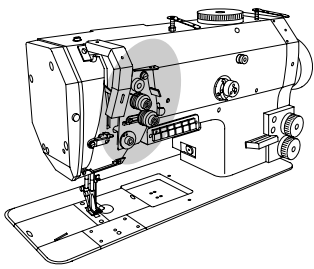

### Kopfteile

Needle head parts

PFAFF 1425-900/81;-900/82

Pièces de tête

PFAFF 1426-900/81

Piezas de la cabeza

PFAFF 3715-2/01;-2/02

# 3.02

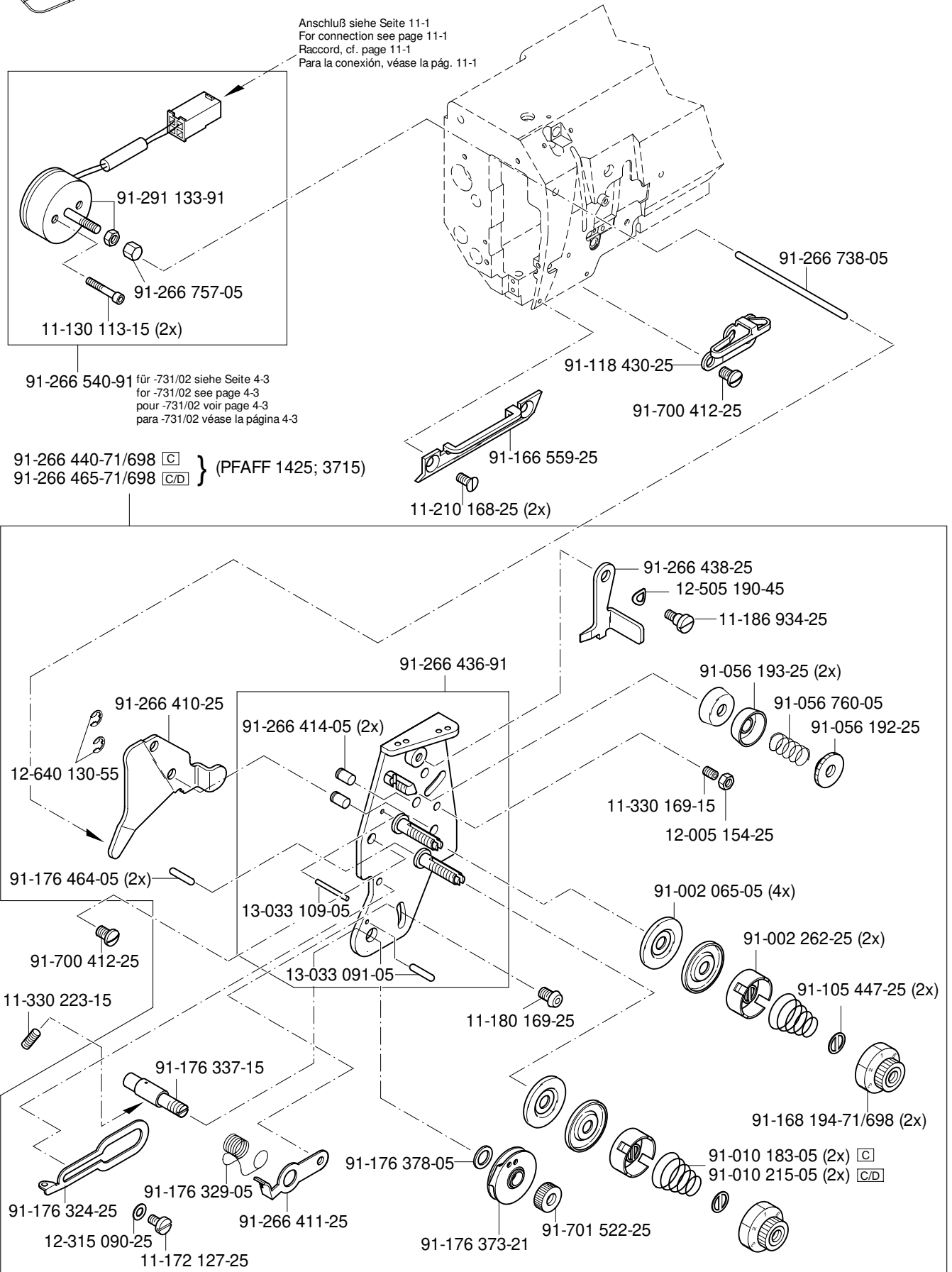

# 3.02

Kopfteile  
Needle head parts  
Pièces de tête  
Piezas de la cabeza

PFAFF 1426-900/81

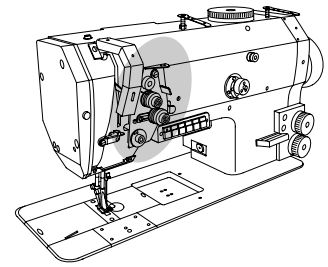

91-266 447-71/698 C  
91-266 463-71/698 CD

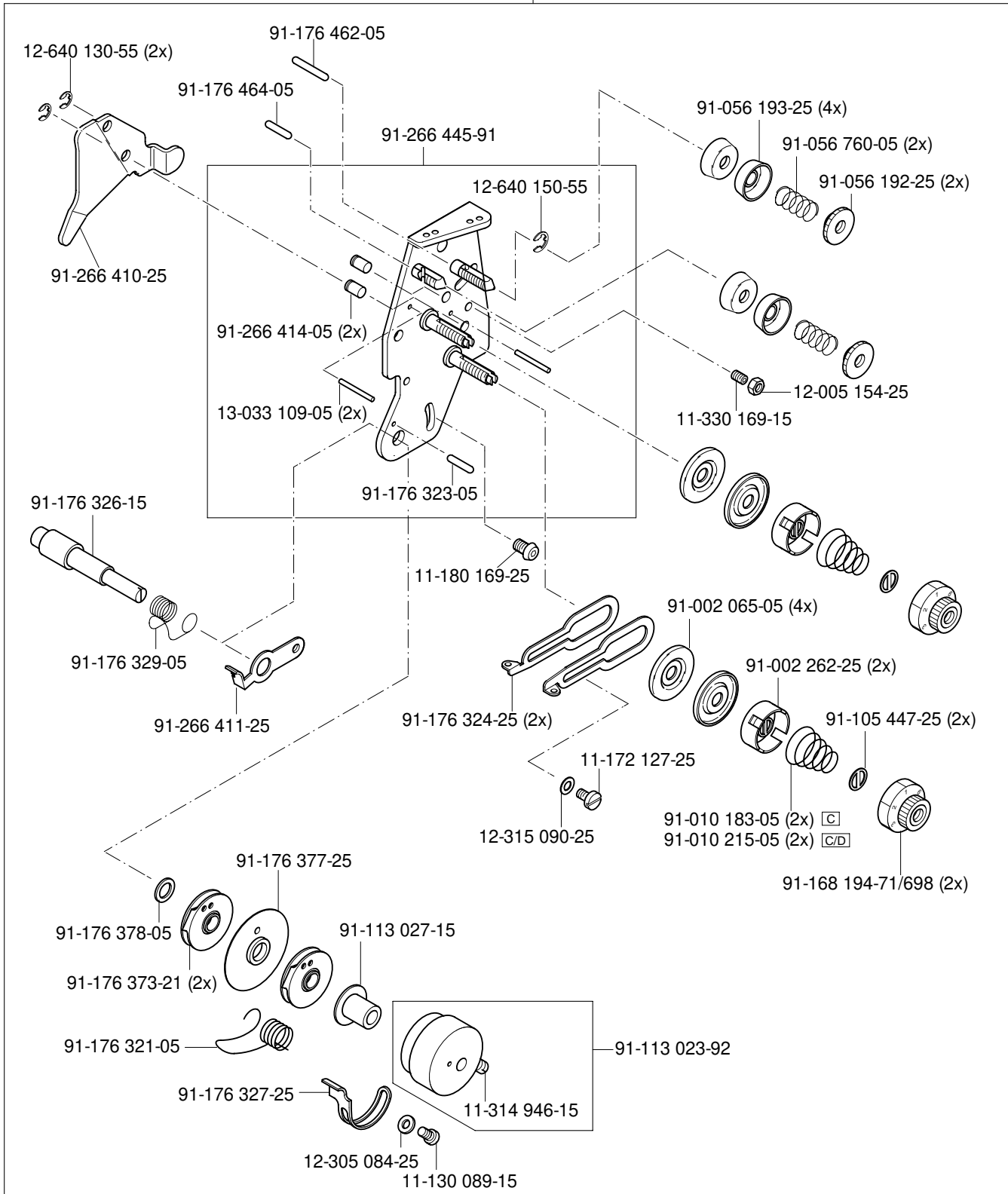

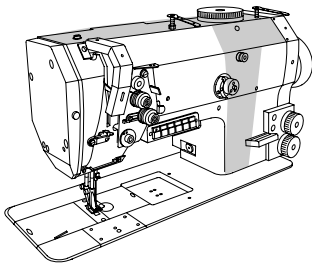

Armteile  
 Arm parts  
 Pièces de bras  
 Piezas del brazo

PFAFF 1425-900/81;-900/82  
 PFAFF 1426-900/81  
 PFAFF 3715-2/01;-2/02

3.03

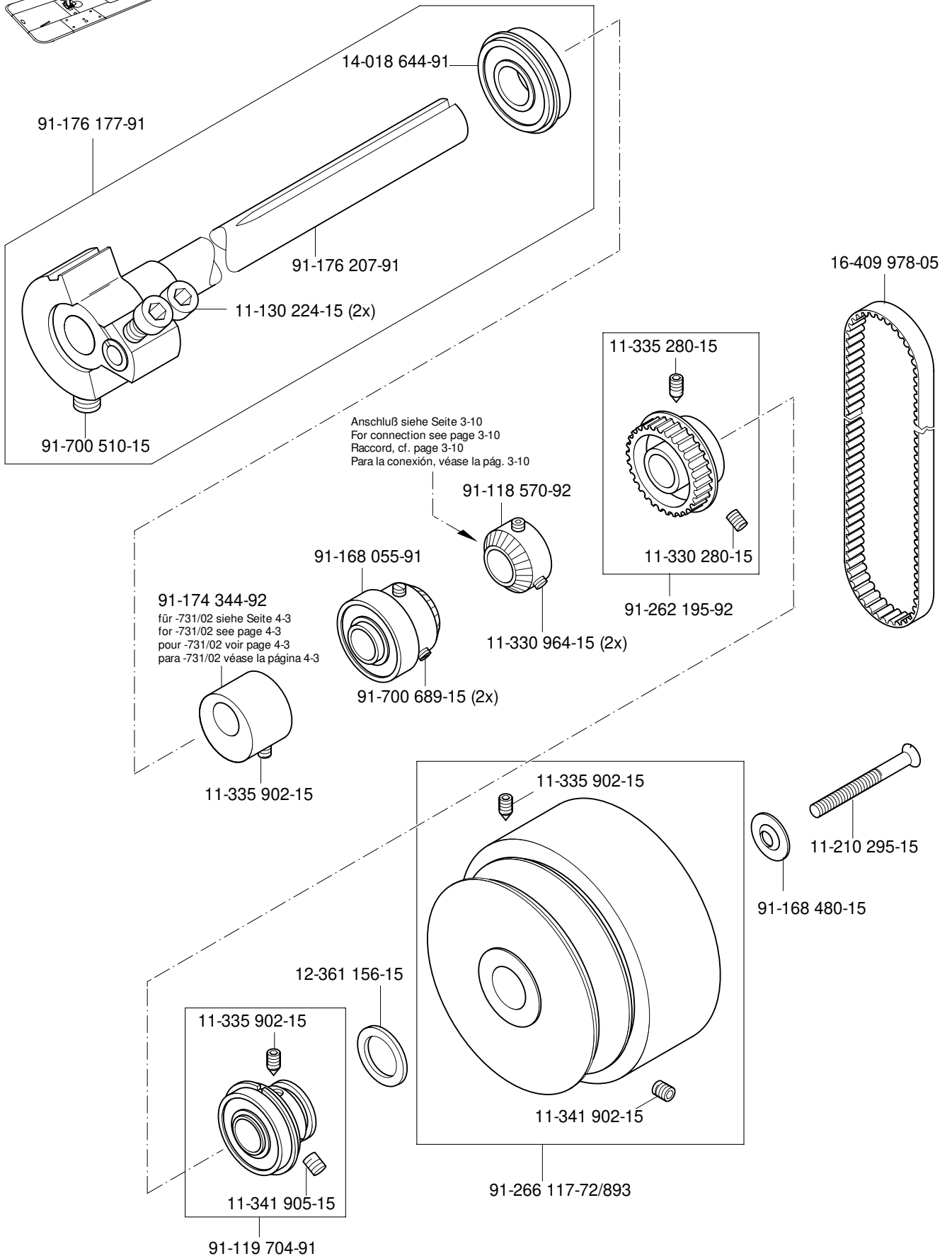

# 3.03

Armteile

Arm parts

Pièces de bras

Piezas del brazo

PFAFF 1425-900/81;-900/82

PFAFF 1426-900/81

PFAFF 3715-2/01;-2/02

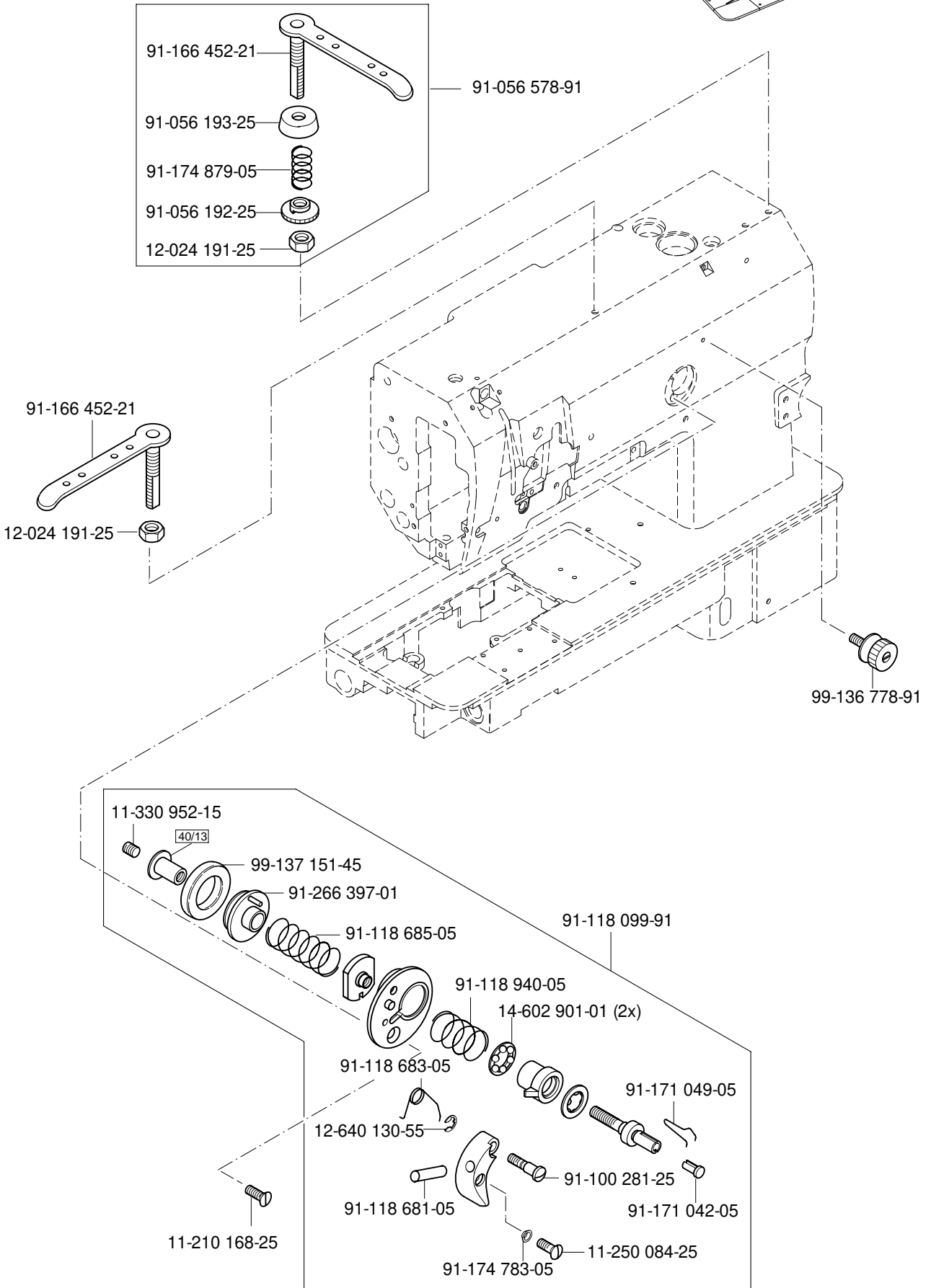
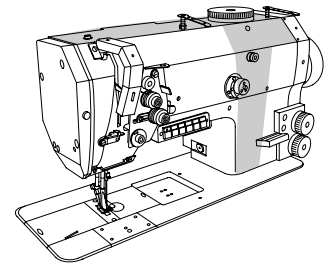

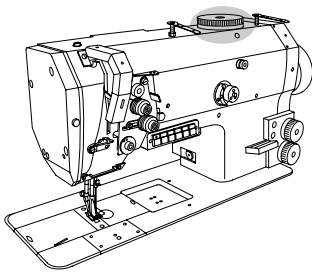

Armteile

Arm parts

Pièces de bras

Piezas del brazo

PFAFF 1425-900/81;-900/82

PFAFF 1426-900/81

PFAFF 3715-2/01;-2/02

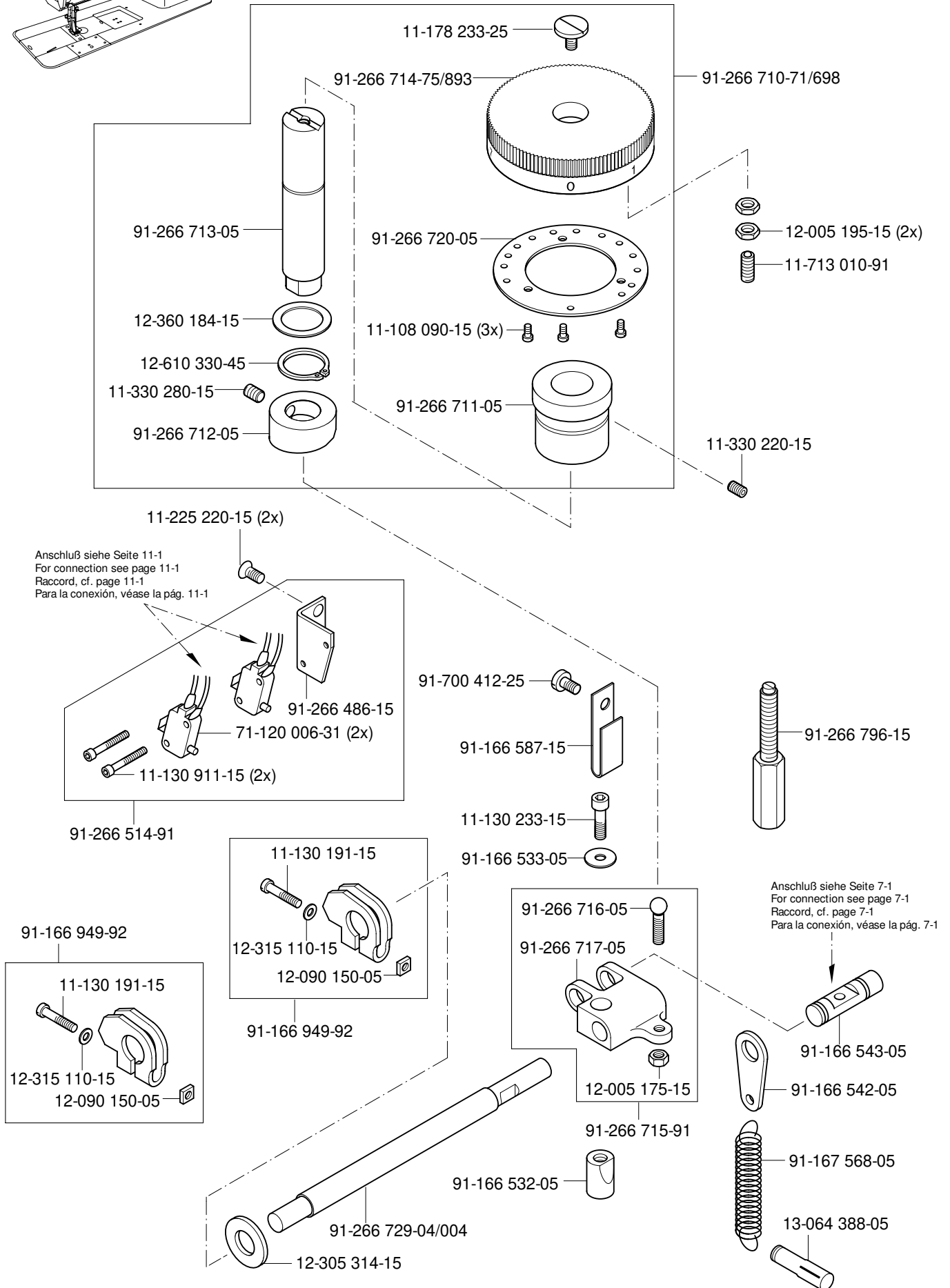

# 3.03

Armteile  
 Arm parts  
 Pièces de bras  
 Piezas del brazo

PFAFF 1425-900/81;-900/82  
 PFAFF 1426-900/81  
 PFAFF 3715-2/01;-2/02

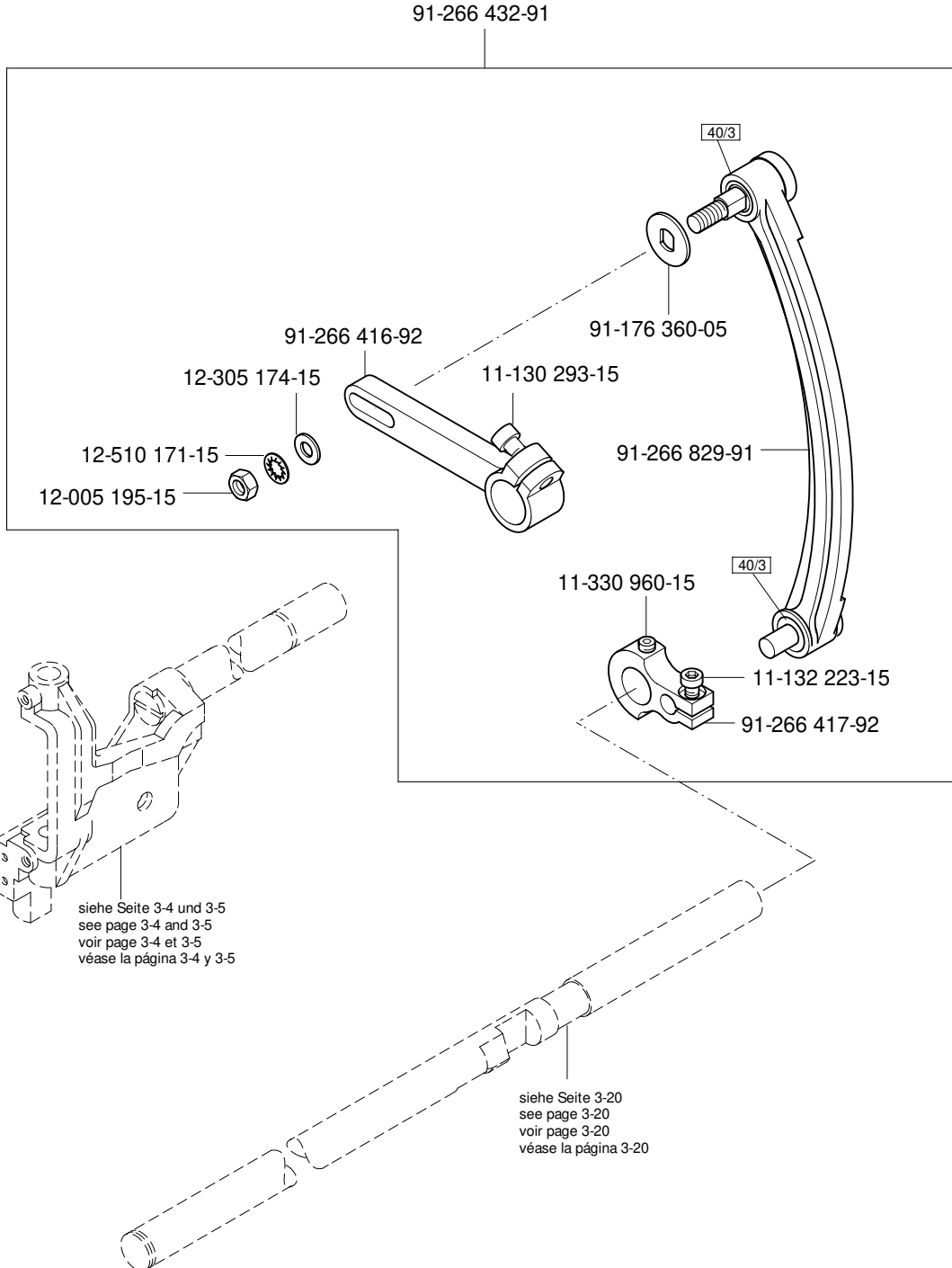
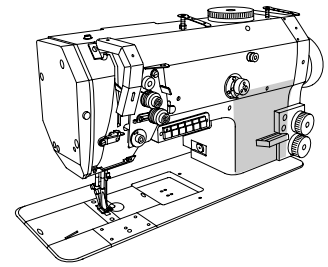



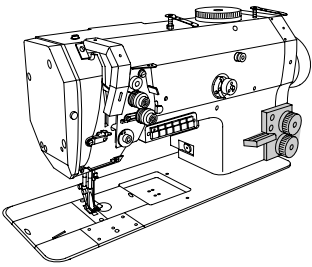

Armteile

Arm parts

Pièces de bras

Piezas del brazo

PFAFF 1425-900/81;-900/82

PFAFF 1426-900/81

PFAFF 3715-2/01;-2/02

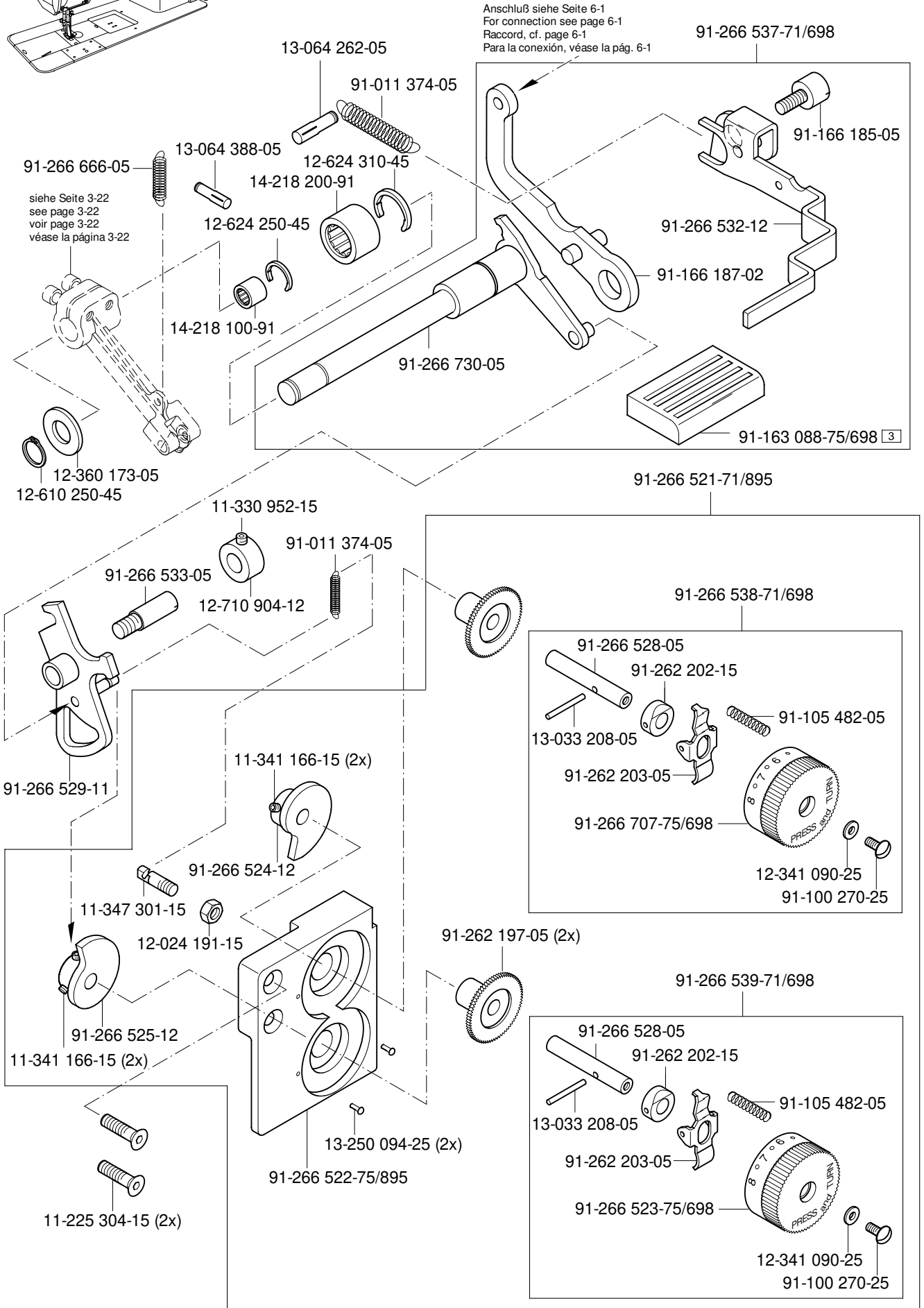

# 3.04

Grundplattenteile  
 Bedplate parts  
 Pièces du plateau fondamental  
 Piezas del cárter

PFAFF 1425-900/81;-900/82  
 PFAFF 1426-900/81  
 PFAFF 3715-2/01;-2/02

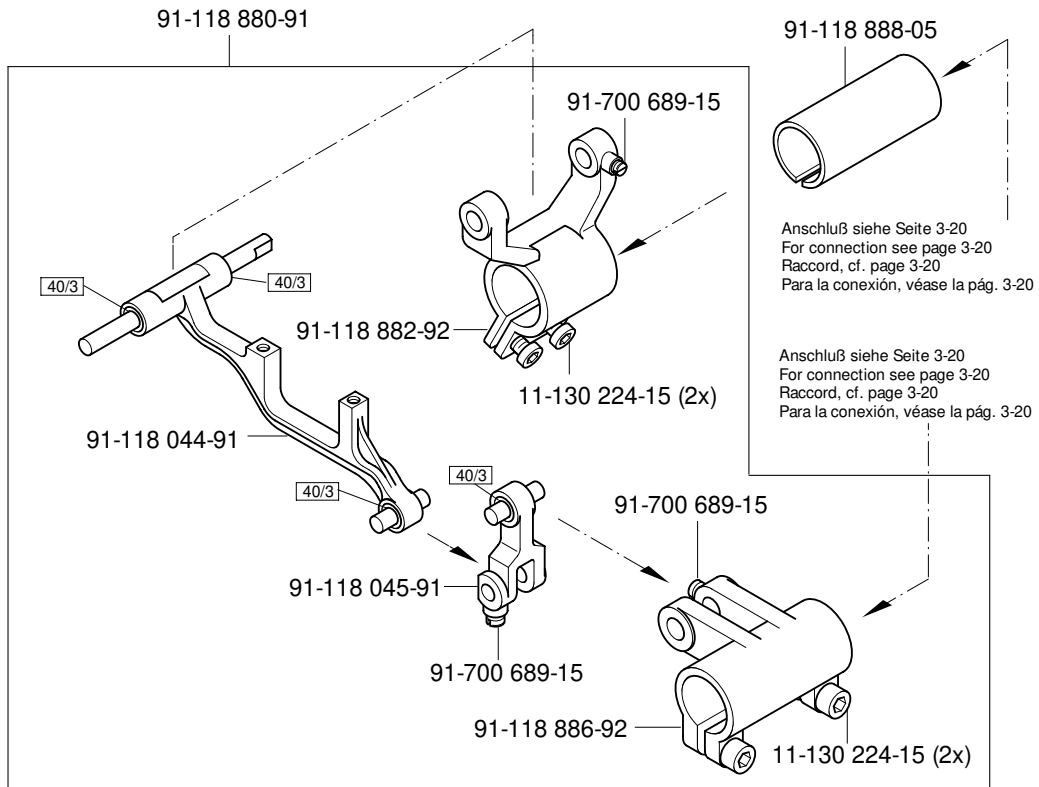
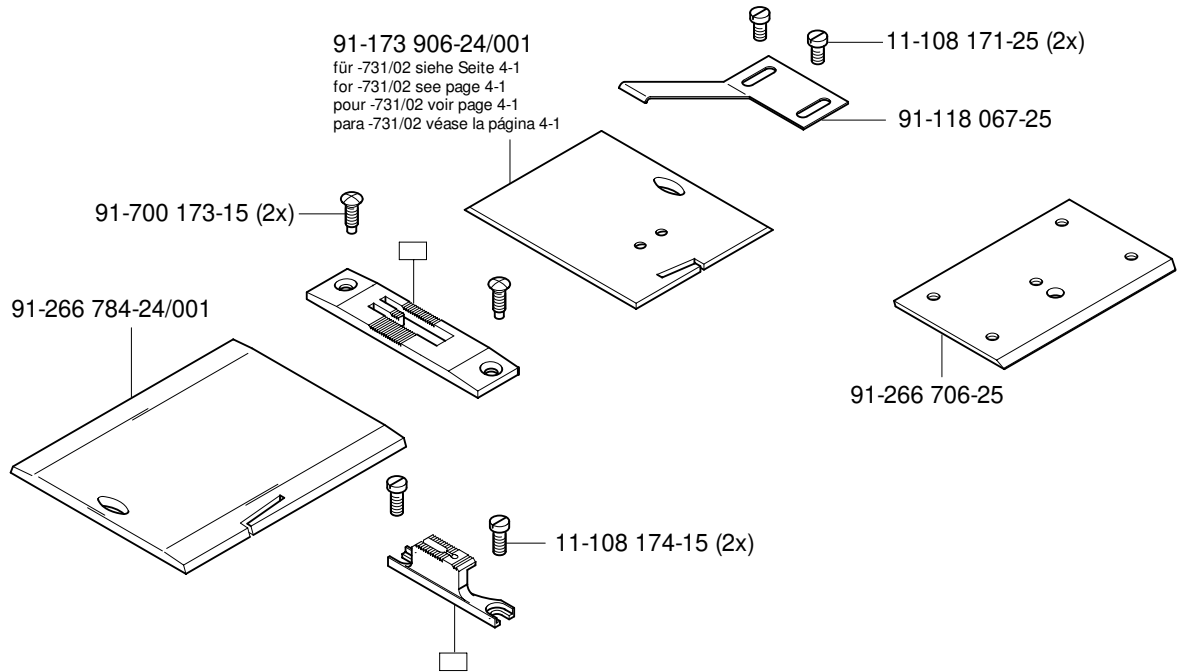
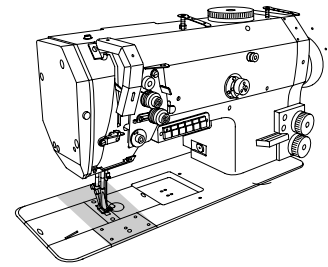

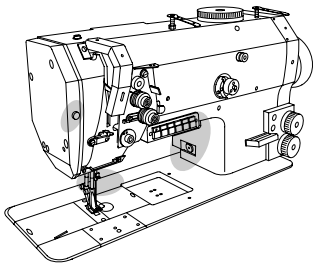

Grundplattenteile  
 Bedplate parts  
 Pièces du plateau fondamental  
 Piezas del cárter

PFAFF 1425-900/81;-900/82  
 PFAFF 1426-900/81  
 PFAFF 3715-2/01;-2/02

# 3.04

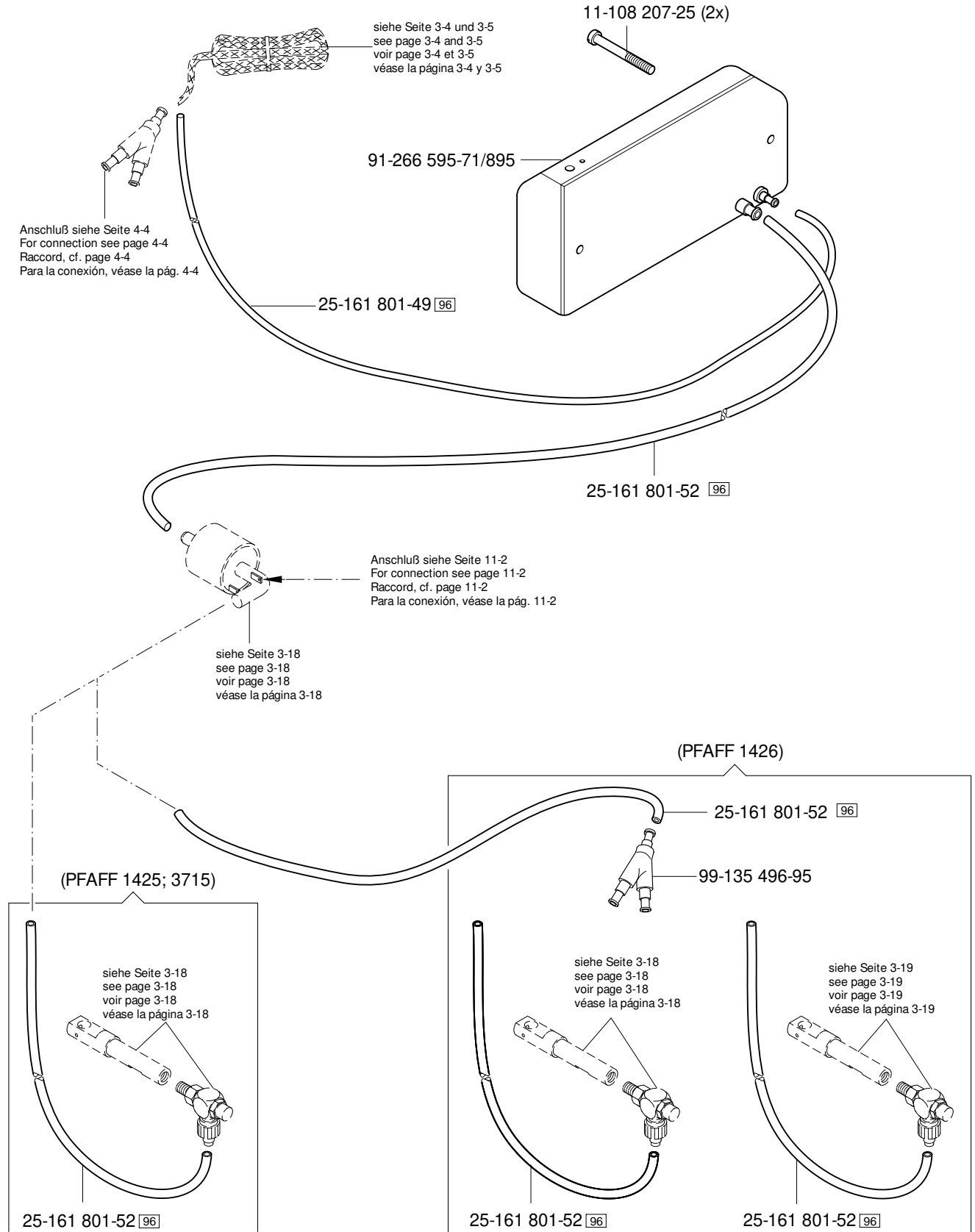

# 3.04

Grundplattenteile  
Bedplate parts  
Pièces du plateau fondamental  
Piezas del cárter

PFAFF 1425-900/81;-900/82  
PFAFF 1426-900/81  
PFAFF 3715-2/01;-2/02

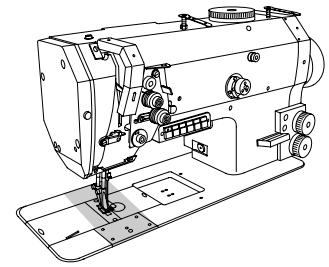

91-018 480-05

für -926/06 siehe Seite 9-2  
for -926/06 see page 9-2  
pour -926/06 voir page 9-2  
para -926/06 véase la página 9-2



91-266 504-91

91-266 685-91 28/1

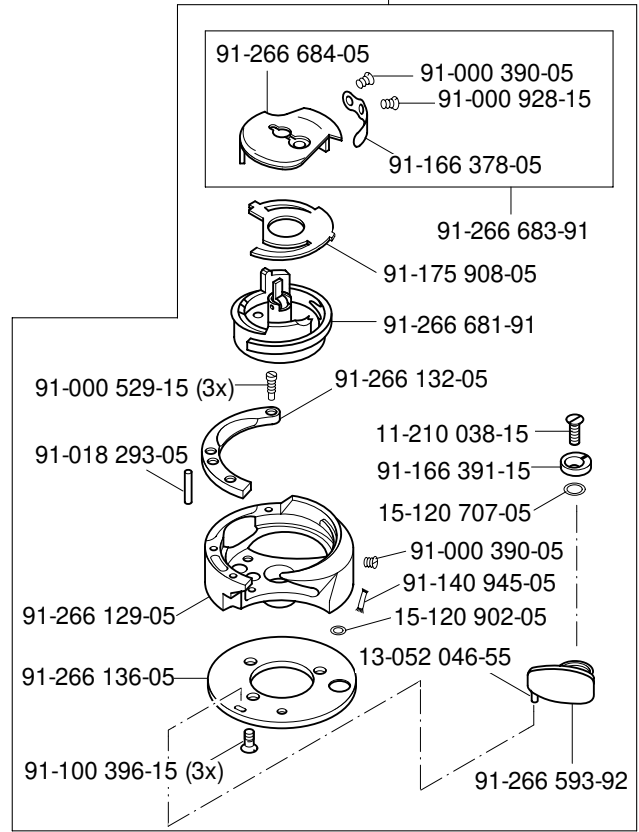
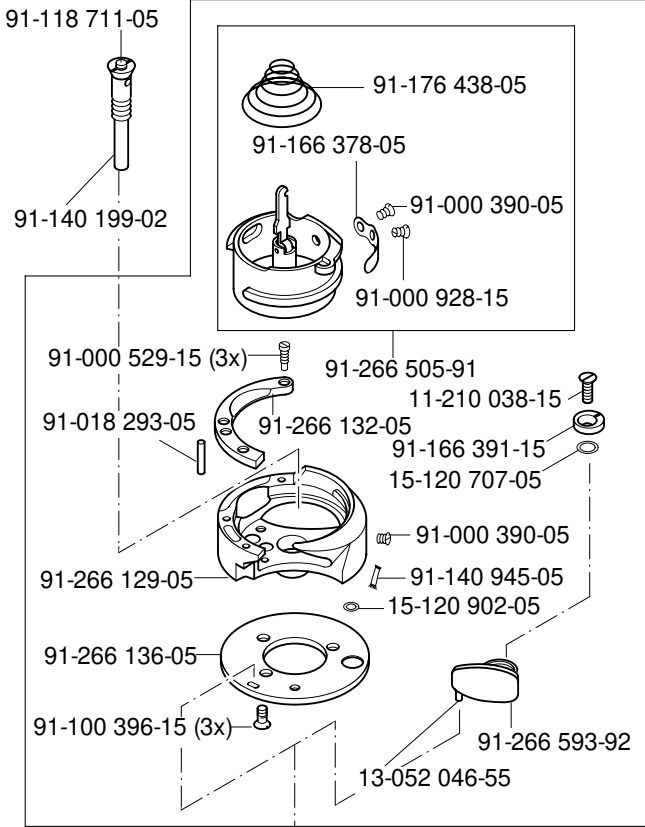

91-166 376-91 (PFAFF 1426)  
(PFAFF 1425 -731/02)

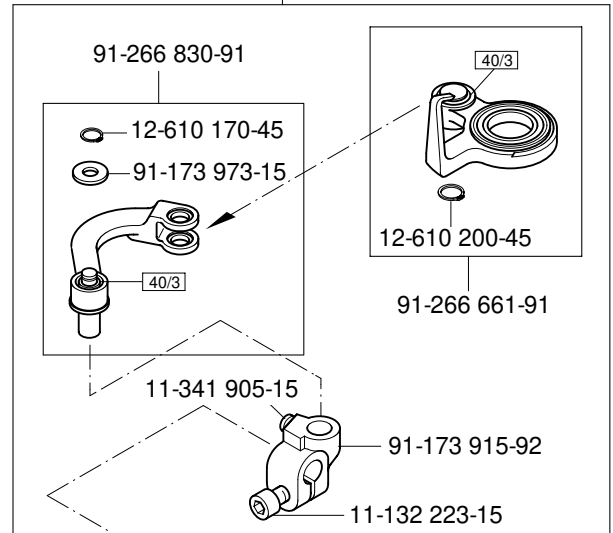
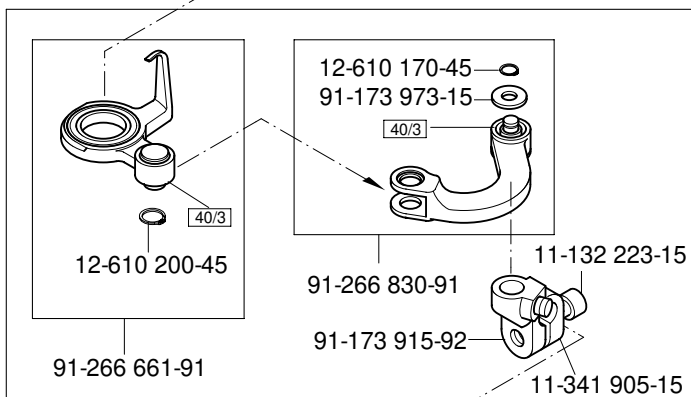

siehe Seite 3-17  
see page 3-17  
voir page 3-17  
véase la página 3-17

91-166 376-91

siehe Seite 3-18  
see page 3-18  
voir page 3-18  
véase la página 3-18

siehe Seite 3-18  
see page 3-18  
voir page 3-18  
véase la página 3-18

siehe Seite 3-17  
see page 3-17  
voir page 3-17  
véase la página 3-17

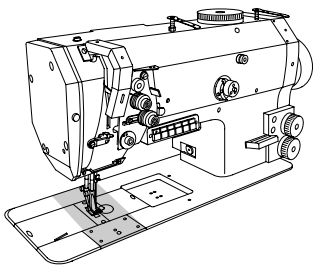

Grundplattenteile  
Bedplate parts  
Pièces du plateau fondamental  
Piezas del cárter

PFAFF 1425-900/81;-900/82  
PFAFF 1426-900/81  
PFAFF 3715-2/01;-2/02

3.04

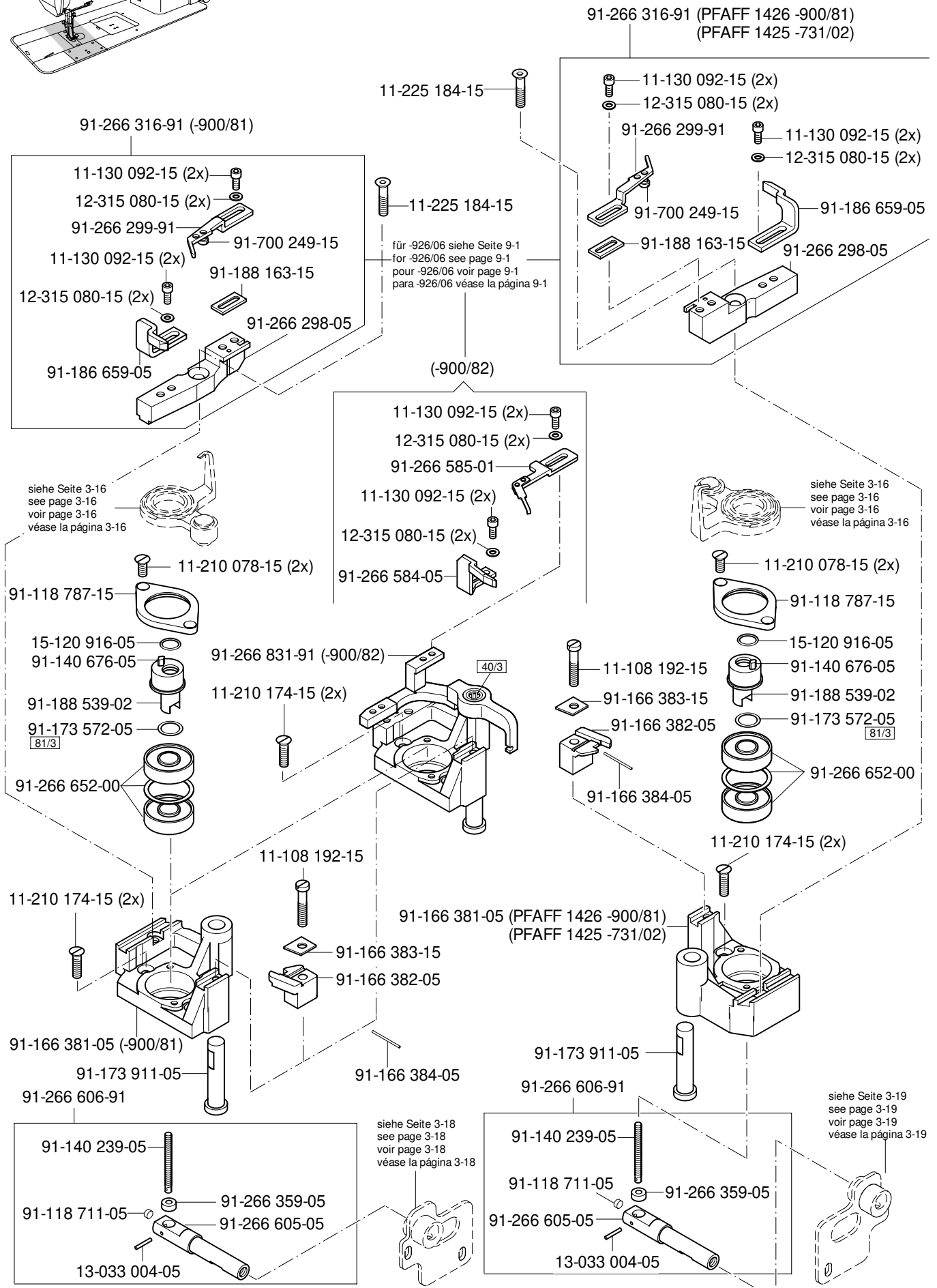



# 3.04

Grundplattenteile  
Bedplate parts  
Pièces du plateau fondamental  
Piezas del cárter

PFAFF 1425-900/81;-900/82  
PFAFF 1426-900/81  
PFAFF 3715-2/01;-2/02

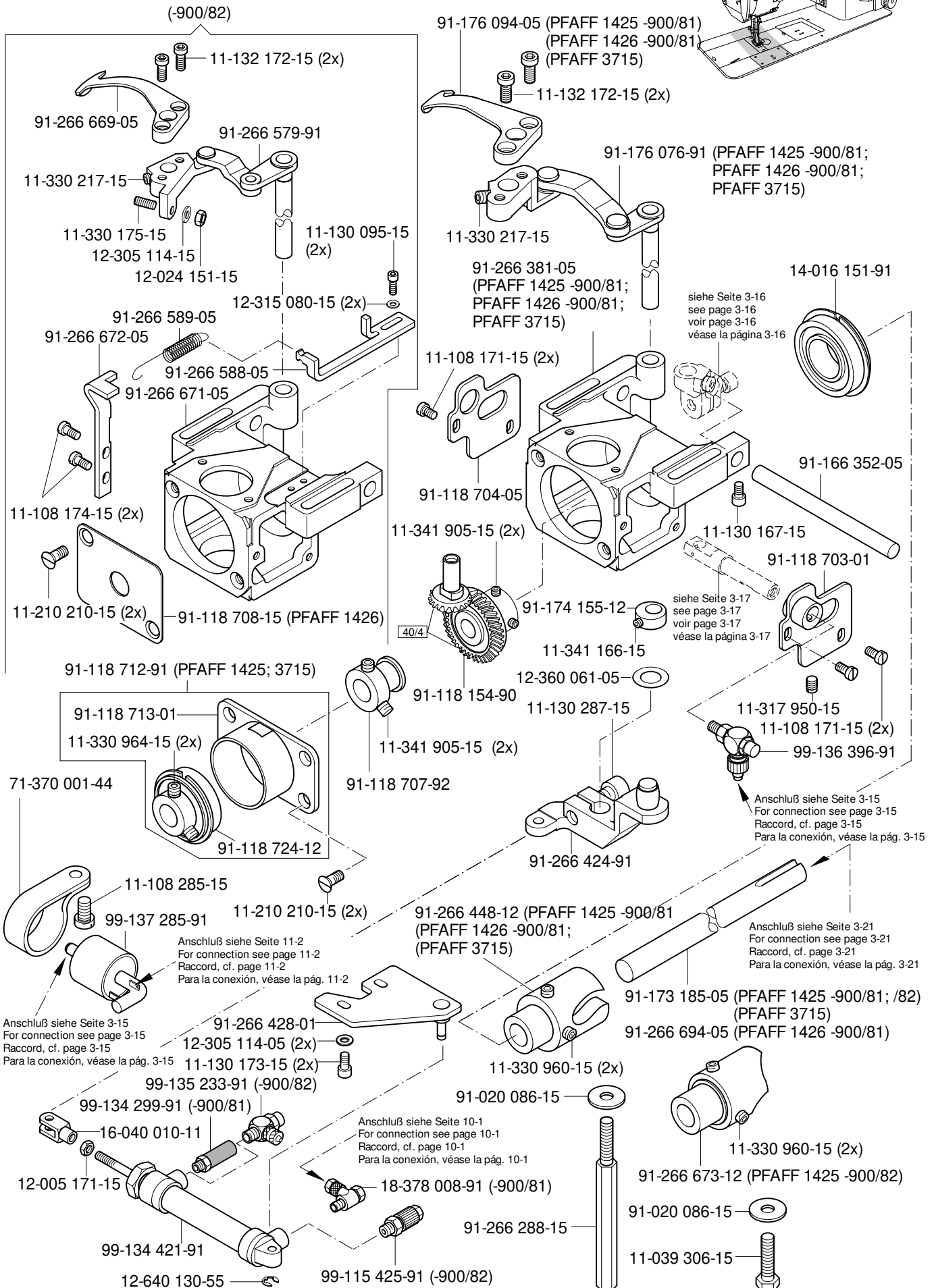
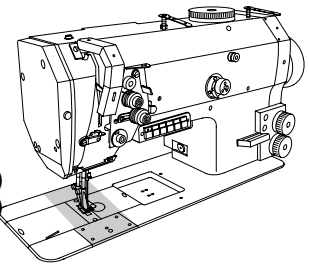

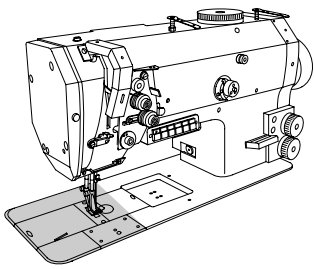

Grundplattenteile  
 Bedplate parts  
 Pièces du plateau fondamental  
 Piezas del cárter

PFAFF 1426-900/81

3.04

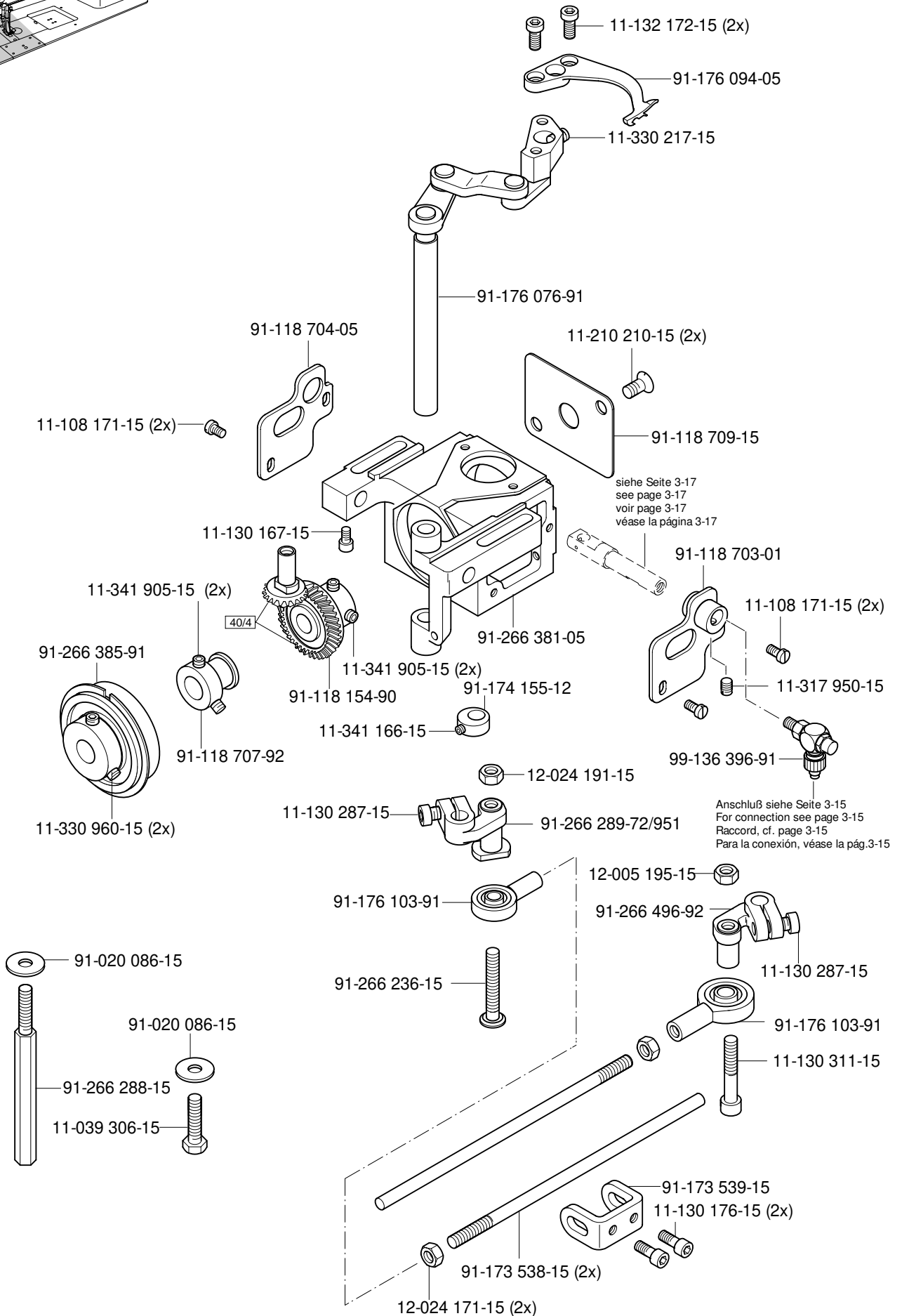

# 3.04

Grundplattenteile  
 Bedplate parts  
 Pièces du plateau fondamental  
 Piezas del cárter

PFAFF 1425-900/81;-900/82  
 PFAFF 1426-900/81  
 PFAFF 3715-2/01;-2/02

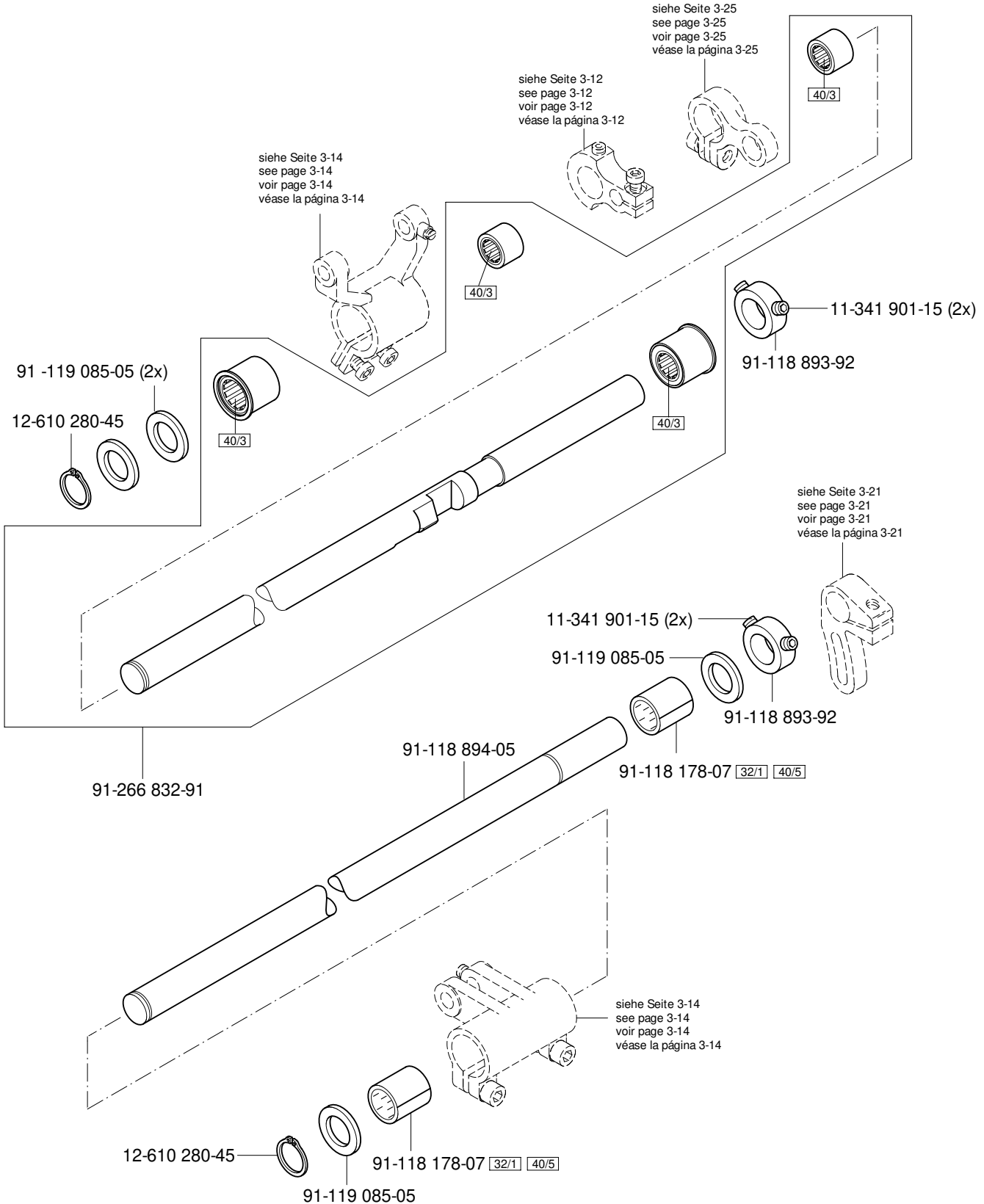
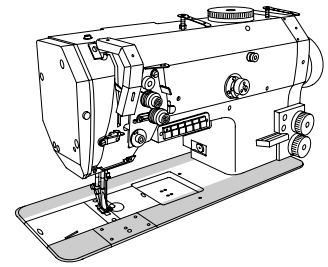



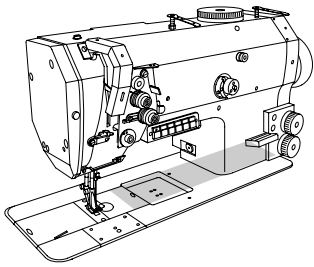

Grundplattenteile  
 Bedplate parts  
 Pièces du plateau fondamental  
 Piezas del cárter

PFAFF 1425-900/81;-900/82  
 PFAFF 1426-900/81  
 PFAFF 3715-2/01;-2/02

3.04

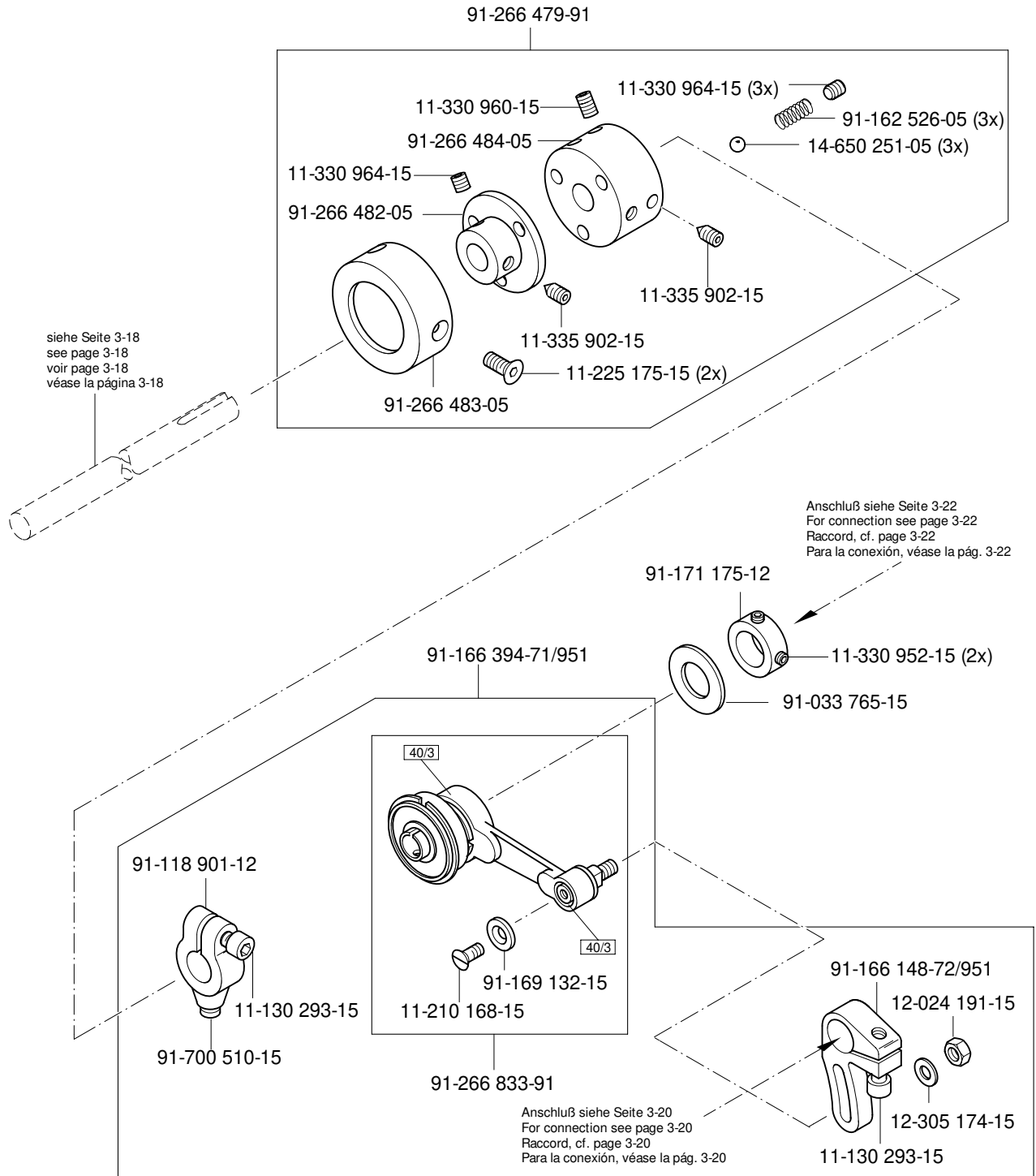

# 3.04

Grundplattenteile  
 Bedplate parts  
 Pièces du plateau fondamental  
 Piezas del cárter

PFAFF 1425-900/81;-900/82  
 PFAFF 1426-900/81  
 PFAFF 3715-2/01;-2/02

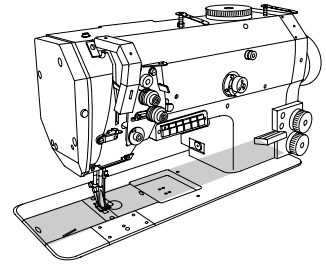

siehe Seite 3-20  
 see page 3-20  
 voir page 3-20  
 véase la página 3-20

siehe Seite 3-13  
 see page 3-13  
 voir page 3-13  
 véase la página 3-13

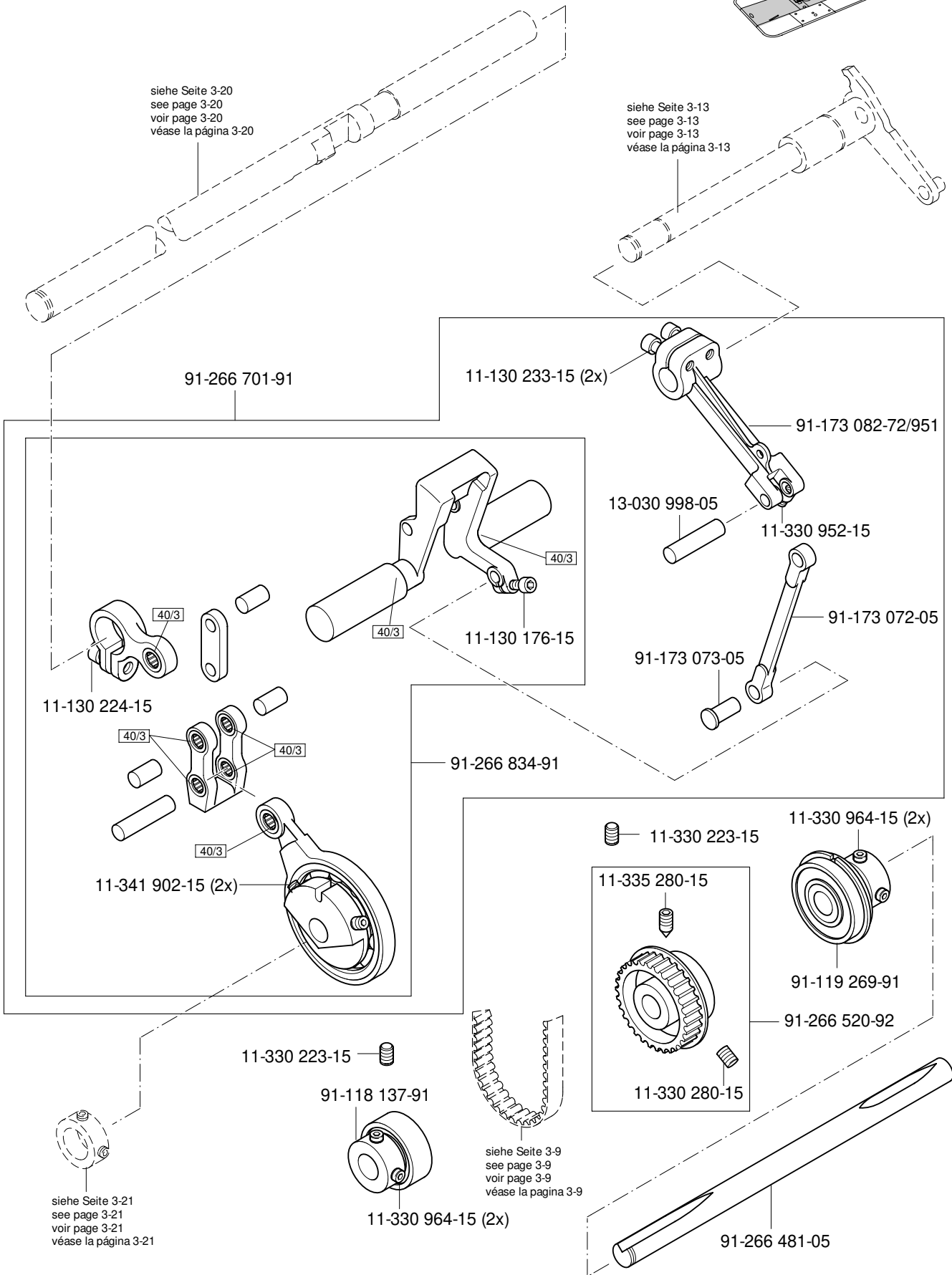

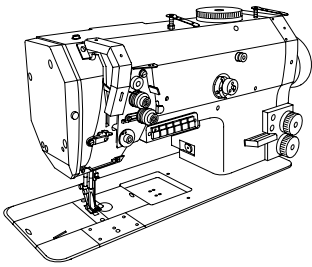

Kanten-Beschneideinrichtung (-731/02)  
 Edge trimmer (-731/02)  
 Couteau (-731/02)  
 Recortador (-731/02)

PFAFF 1425-900/81

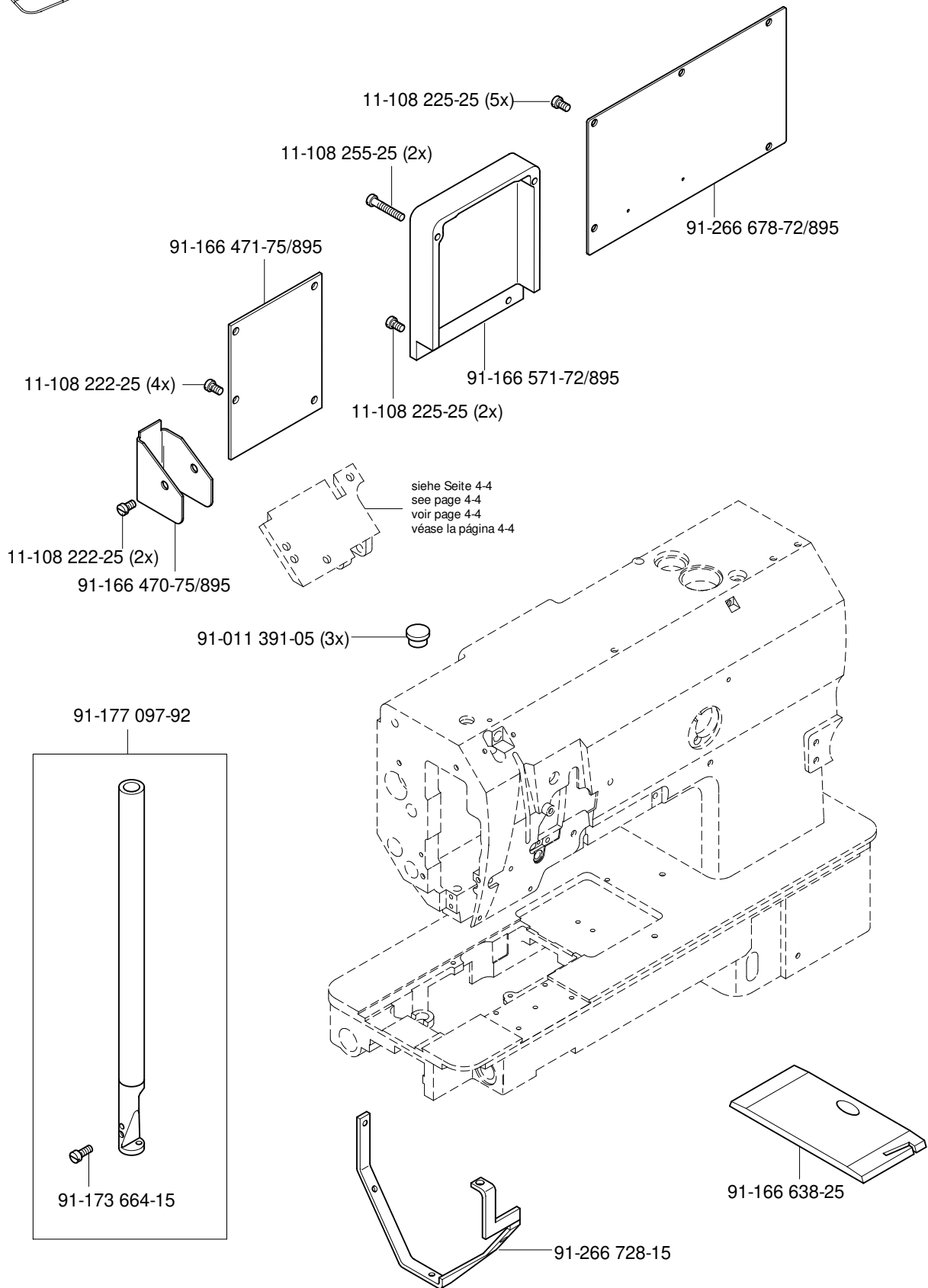

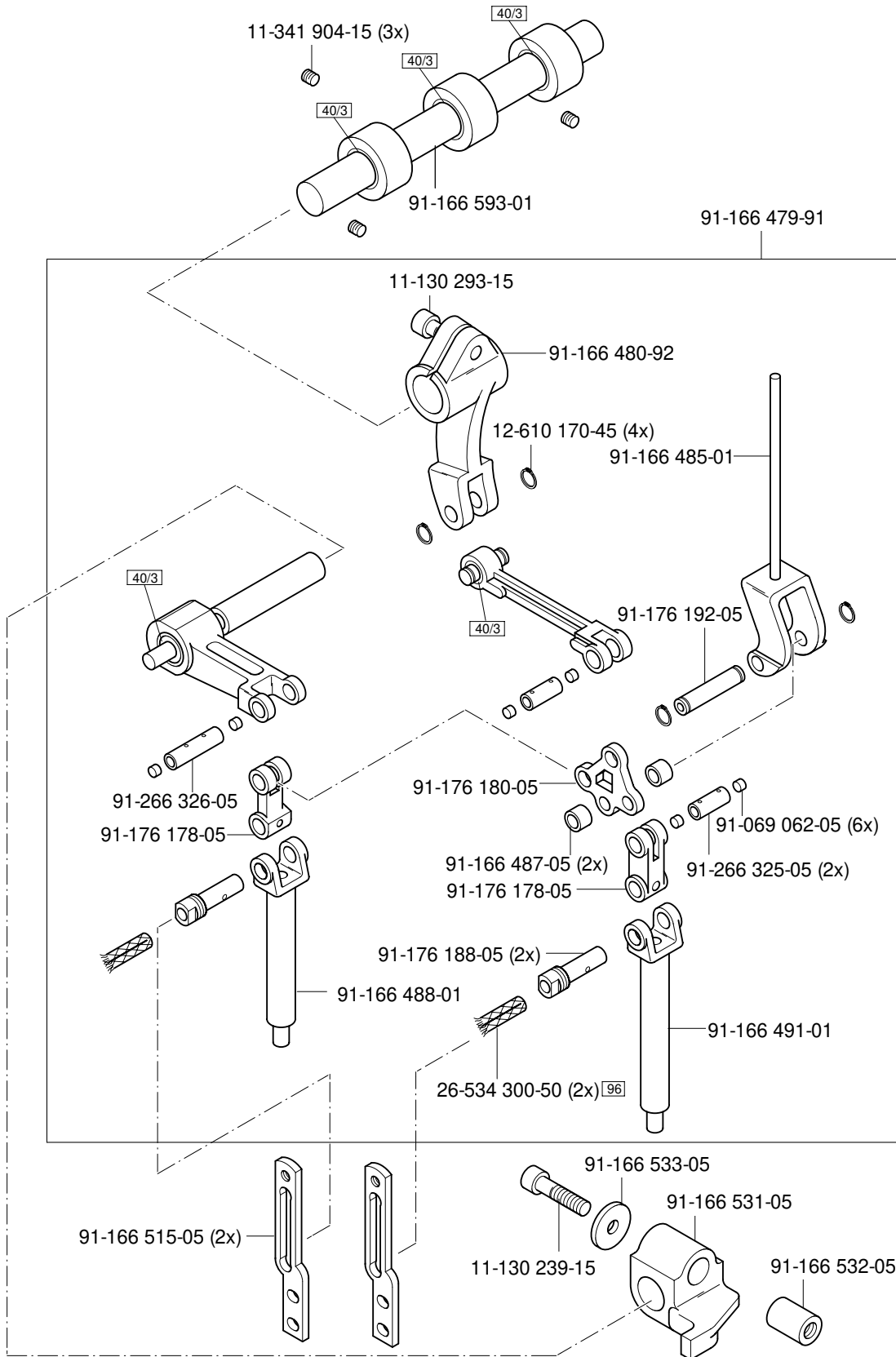
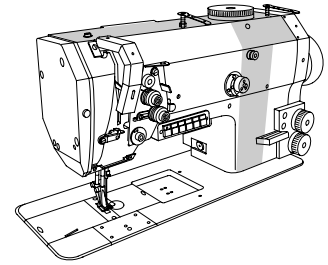

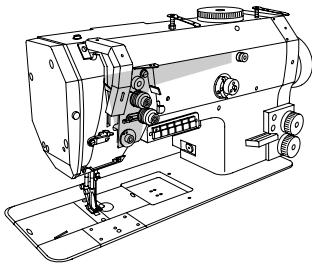

Kanten-Beschneideinrichtung (-731/02)  
 Edge trimmer (-731/02)  
 Couteau (-731/02)  
 Recortador (-731/02)

PFAFF 1425-900/81

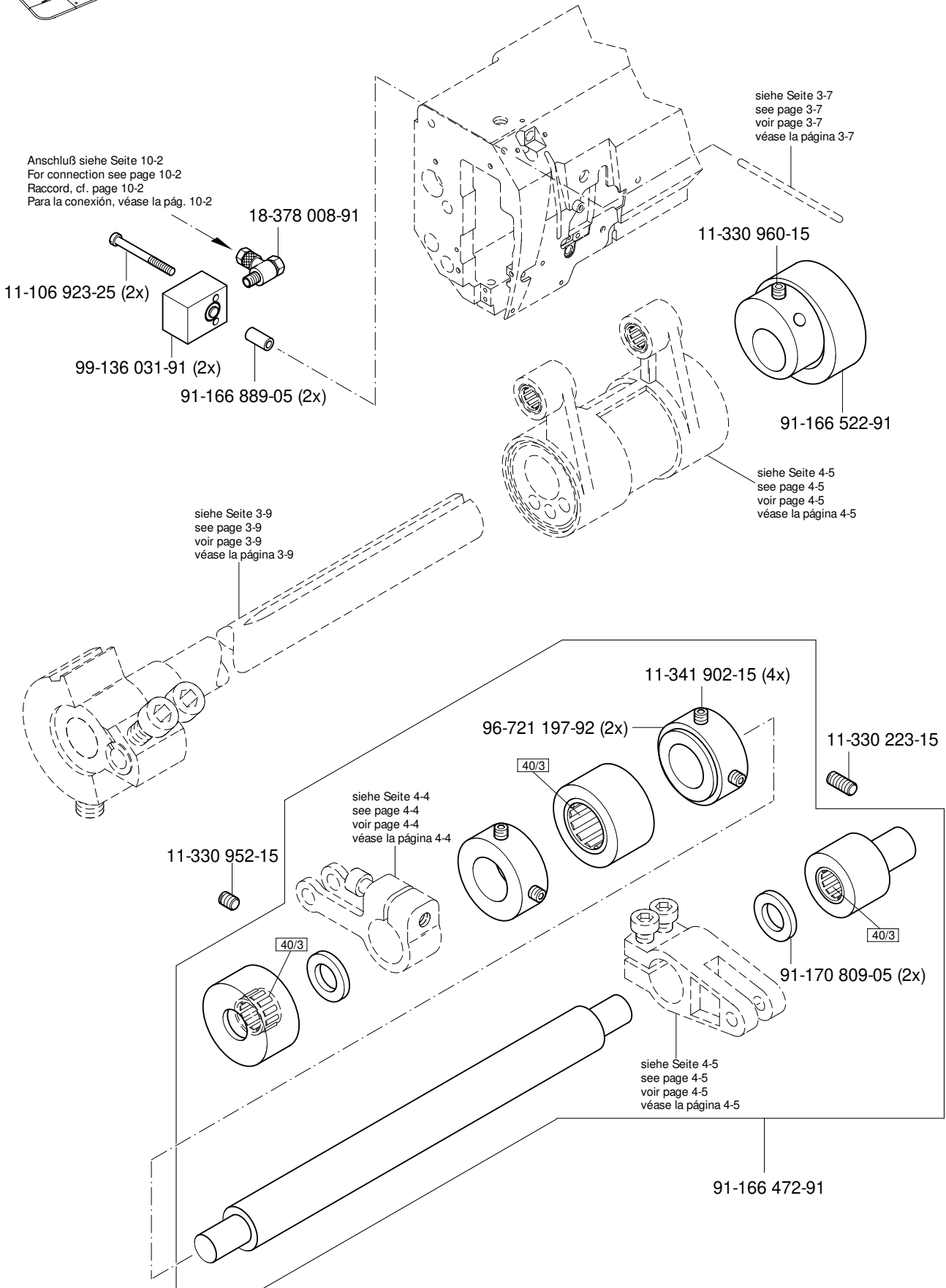

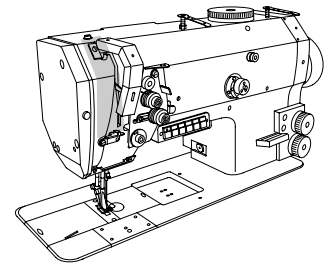

Anschluß siehe Seite 4-3  
 For connection see page 4-3  
 Raccord, cf. page 4-3  
 Para la conexión, véase la pág. 4-3

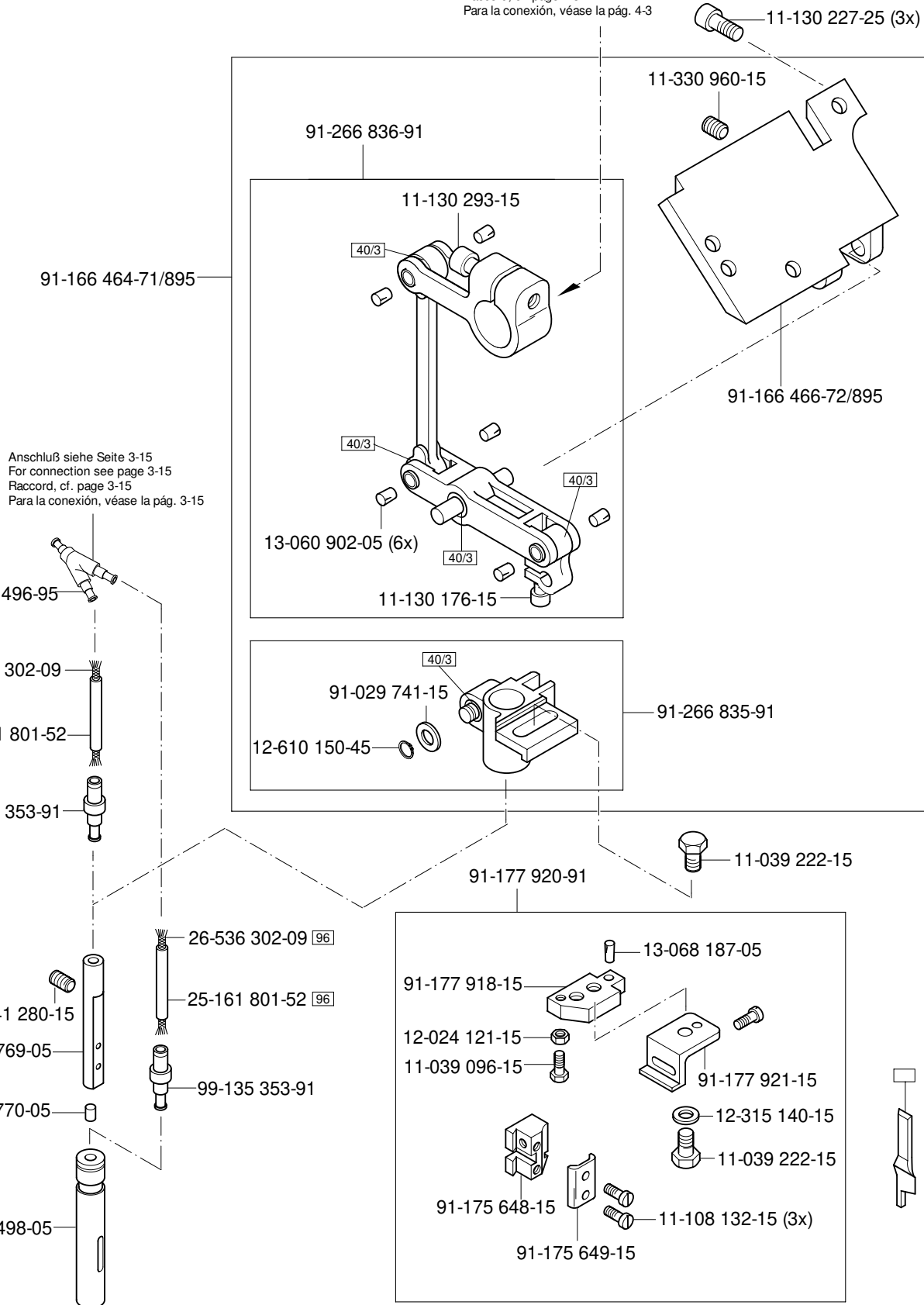

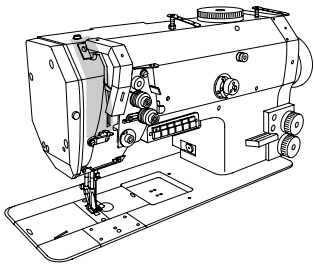

Kanten-Beschneideinrichtung (-731/02)  
 Edge trimmer (-731/02)  
 Couteau (-731/02)  
 Recortador (-731/02)

PFAFF 1425-900/81

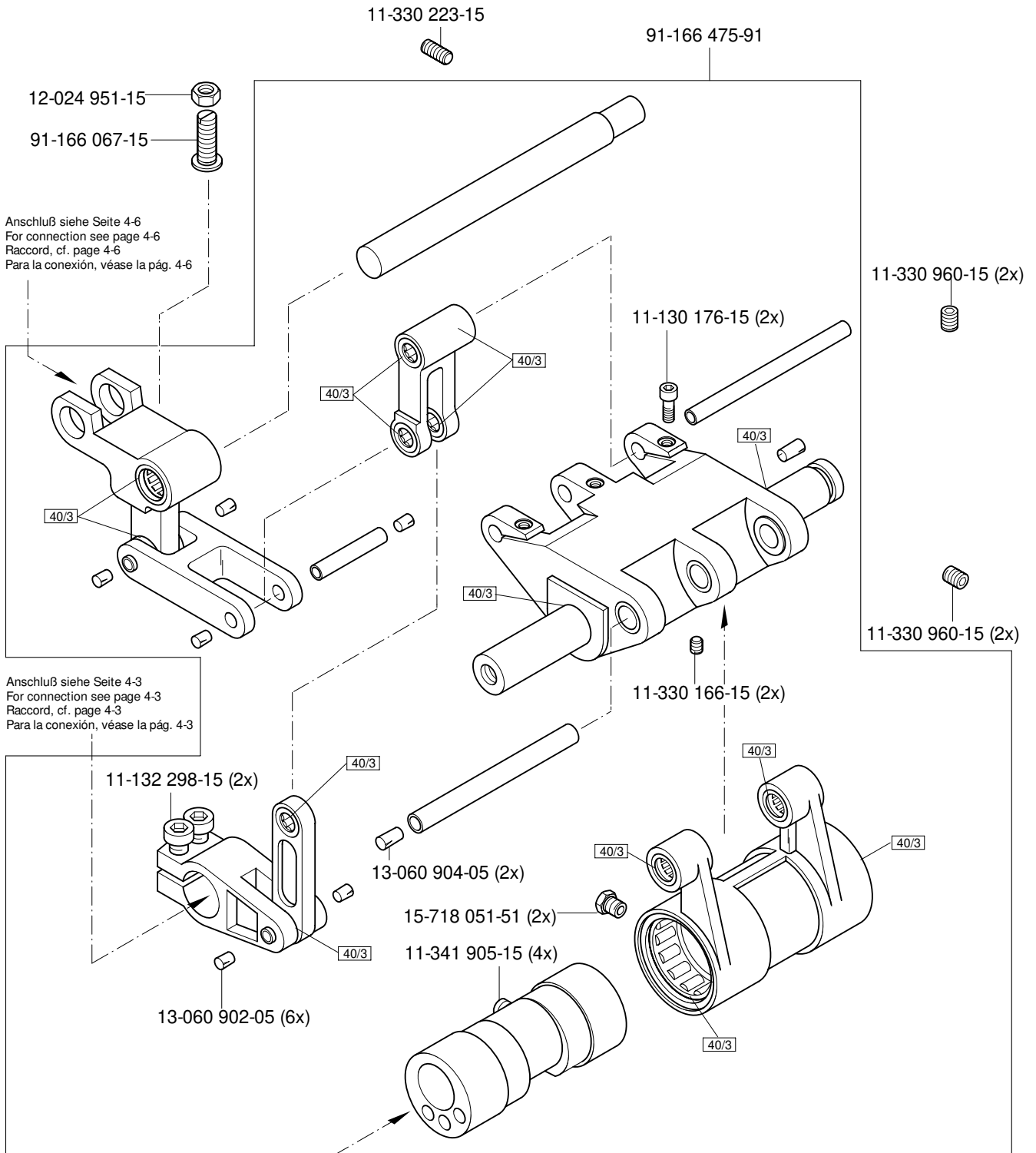

Anschluß siehe Seite 4-3  
 For connection see page 4-3  
 Raccord, cf. page 4-3  
 Para la conexión, véase la pág. 4-3

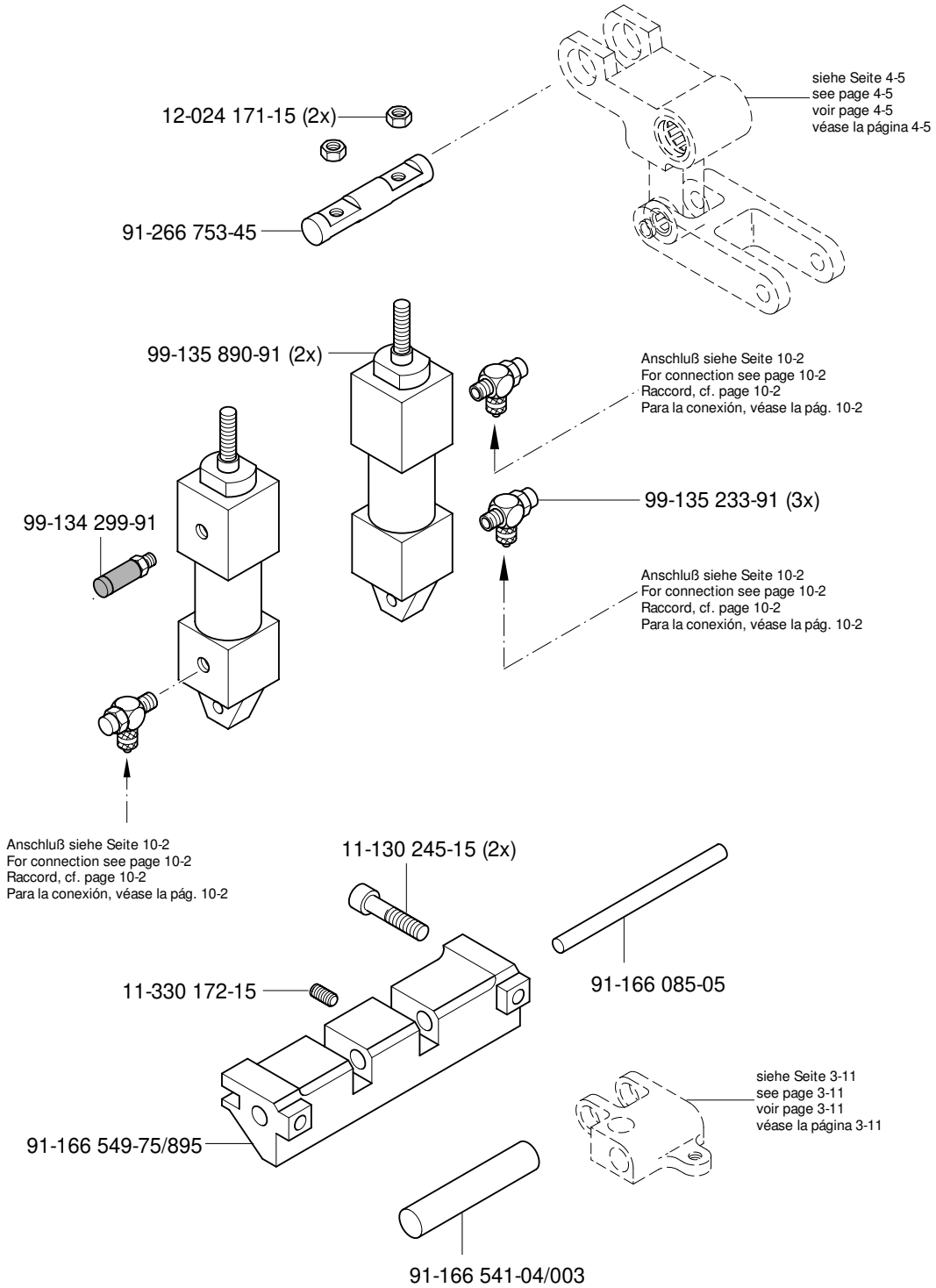
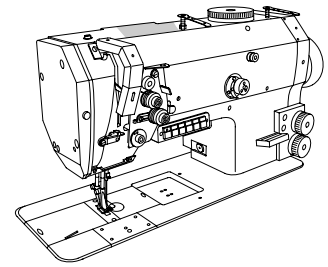



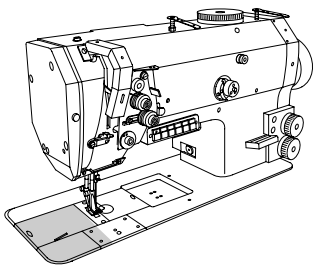

Kanten-Beschneideinrichtung (-731/02)  
 Edge trimmer (-731/02)  
 Couteau (-731/02)  
 Recortador (-731/02)

PFAFF 1425-900/81

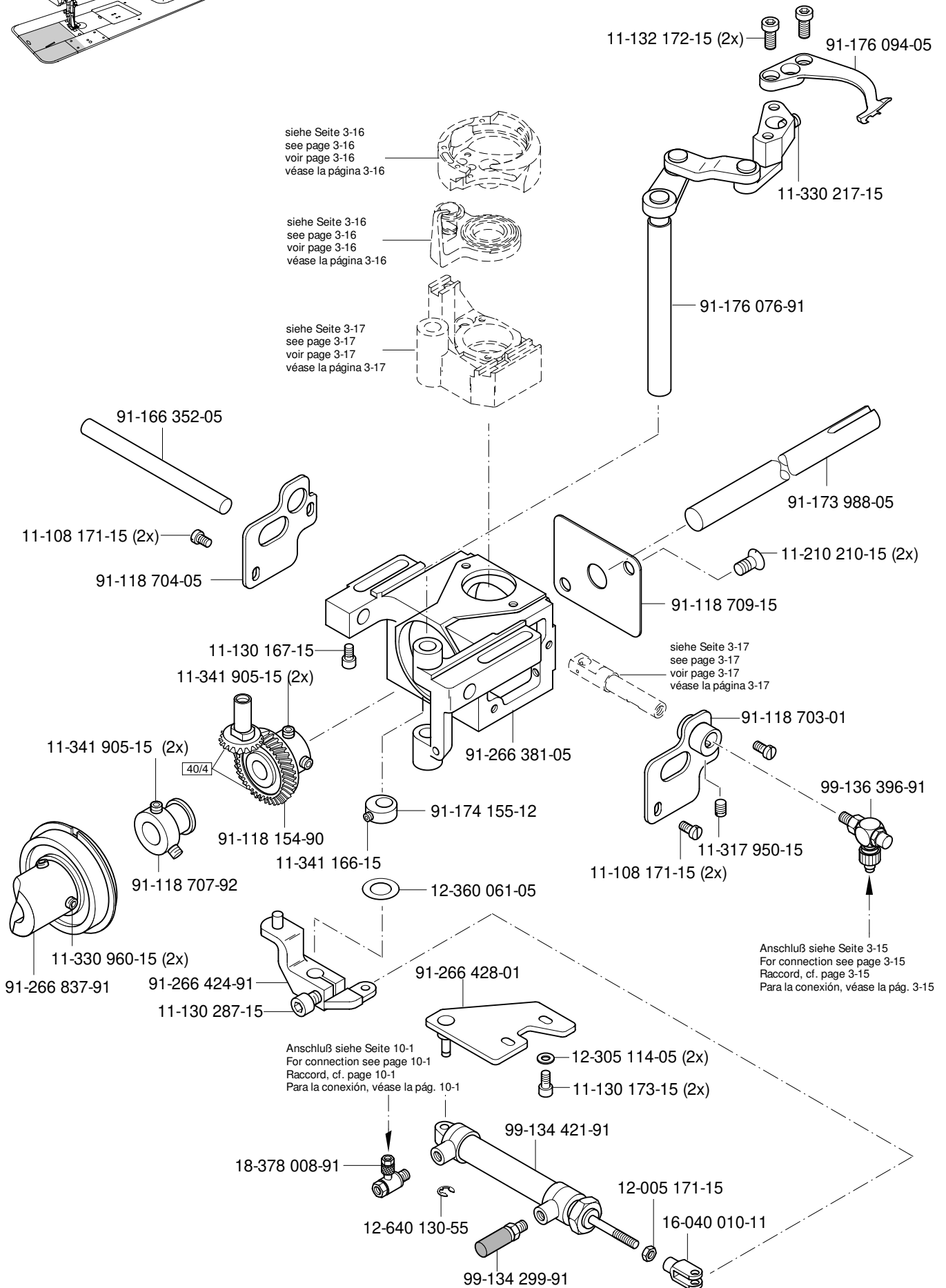

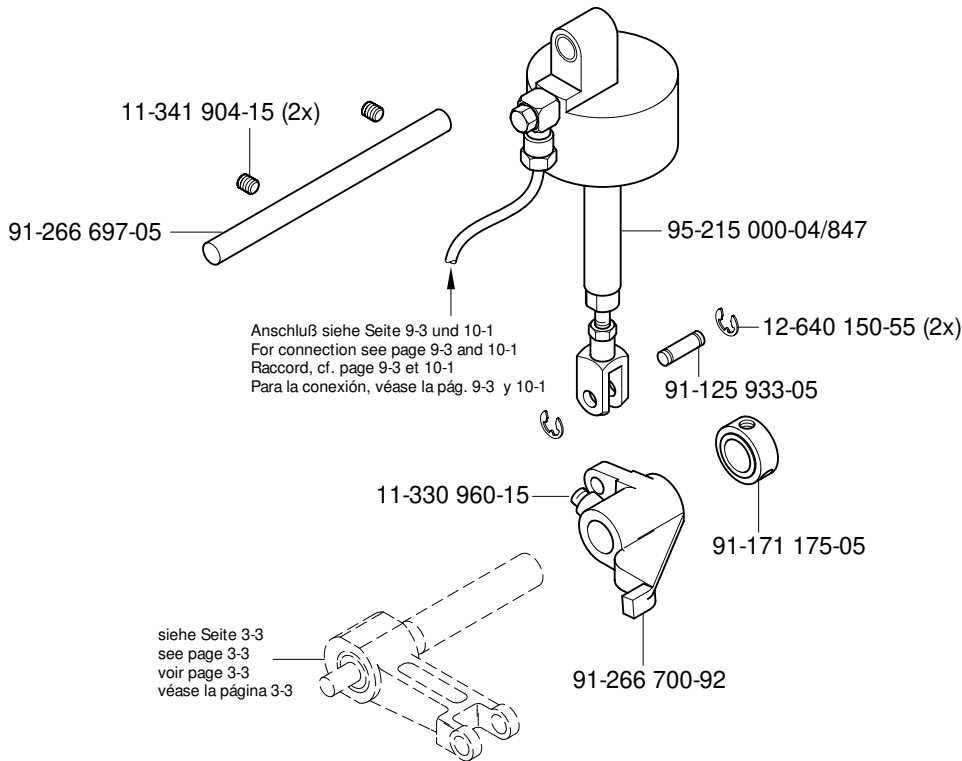
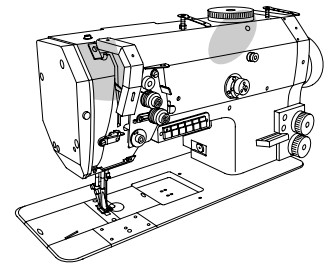

(PFAFF 1425 -731/02; -900/81)

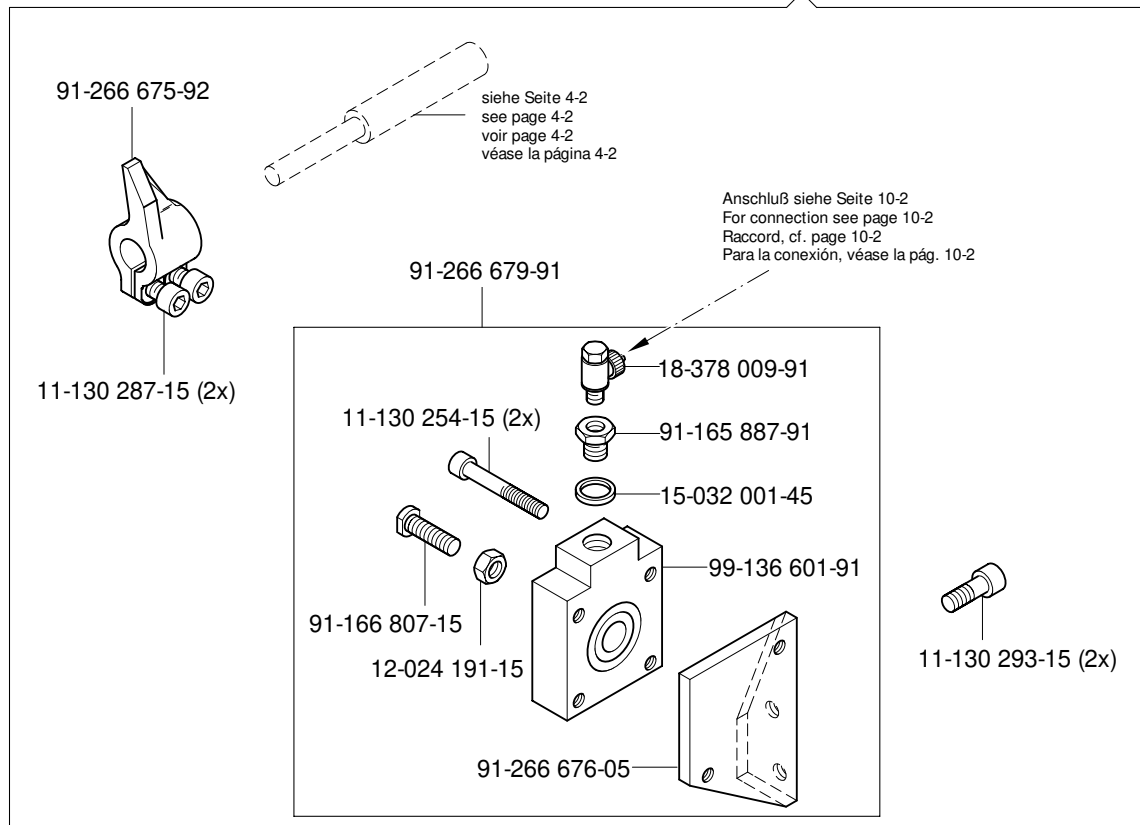

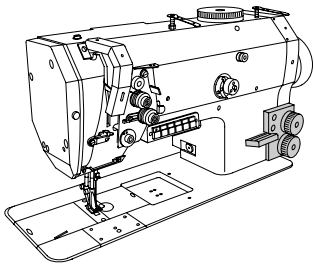

Verriegelungs-Einrichtung (-911/35)  
 Backtacking mechanism (-911/35)  
 Dispositif à points d'arrêt (-911/35)  
 Rematador (-911/35)

PFAFF 1425  
 PFAFF 1426  
 PFAFF 3715

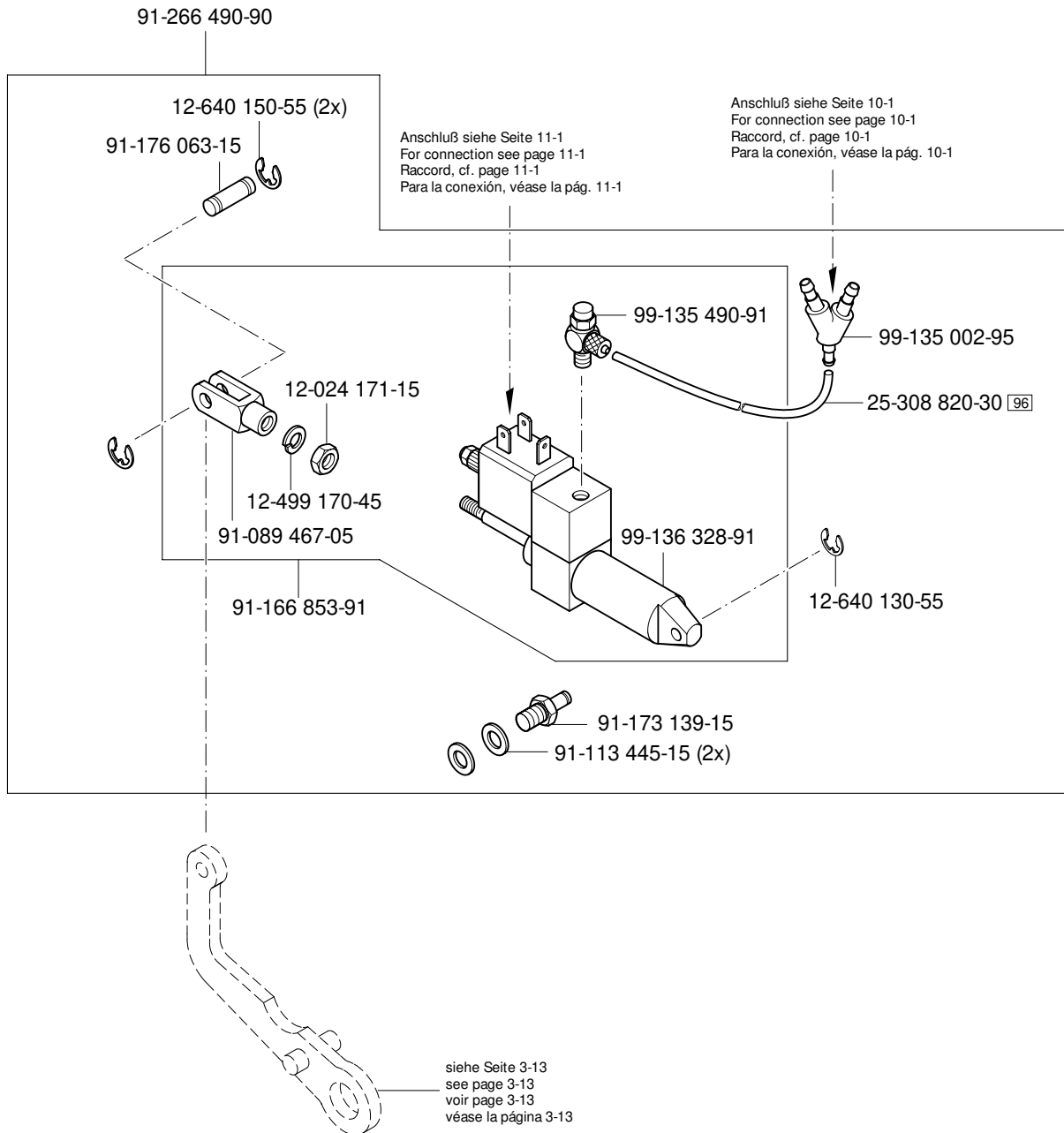

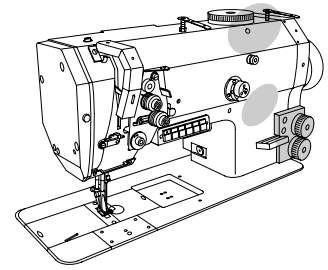

(-918/09)

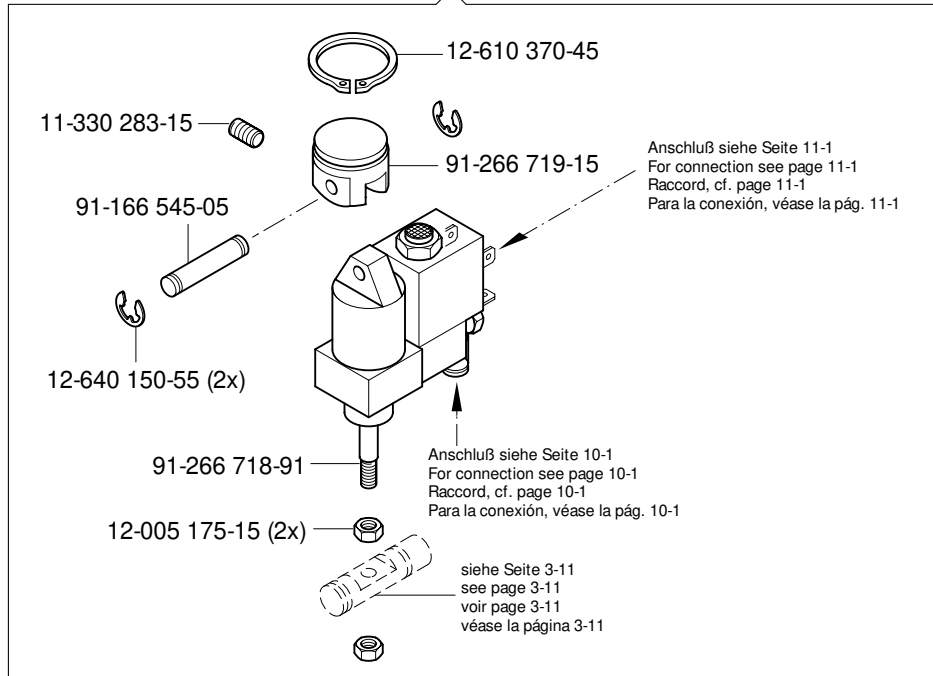

(-918/26)

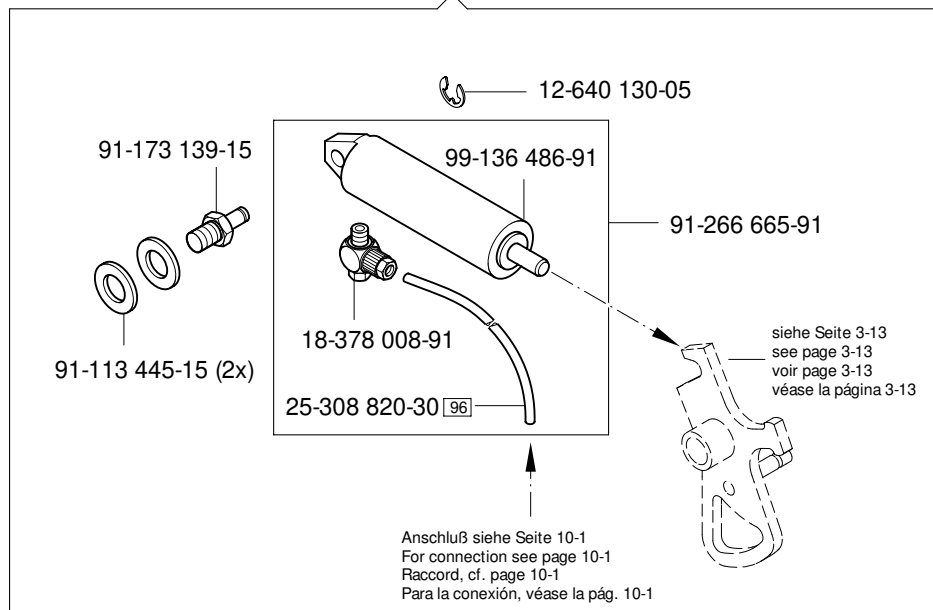

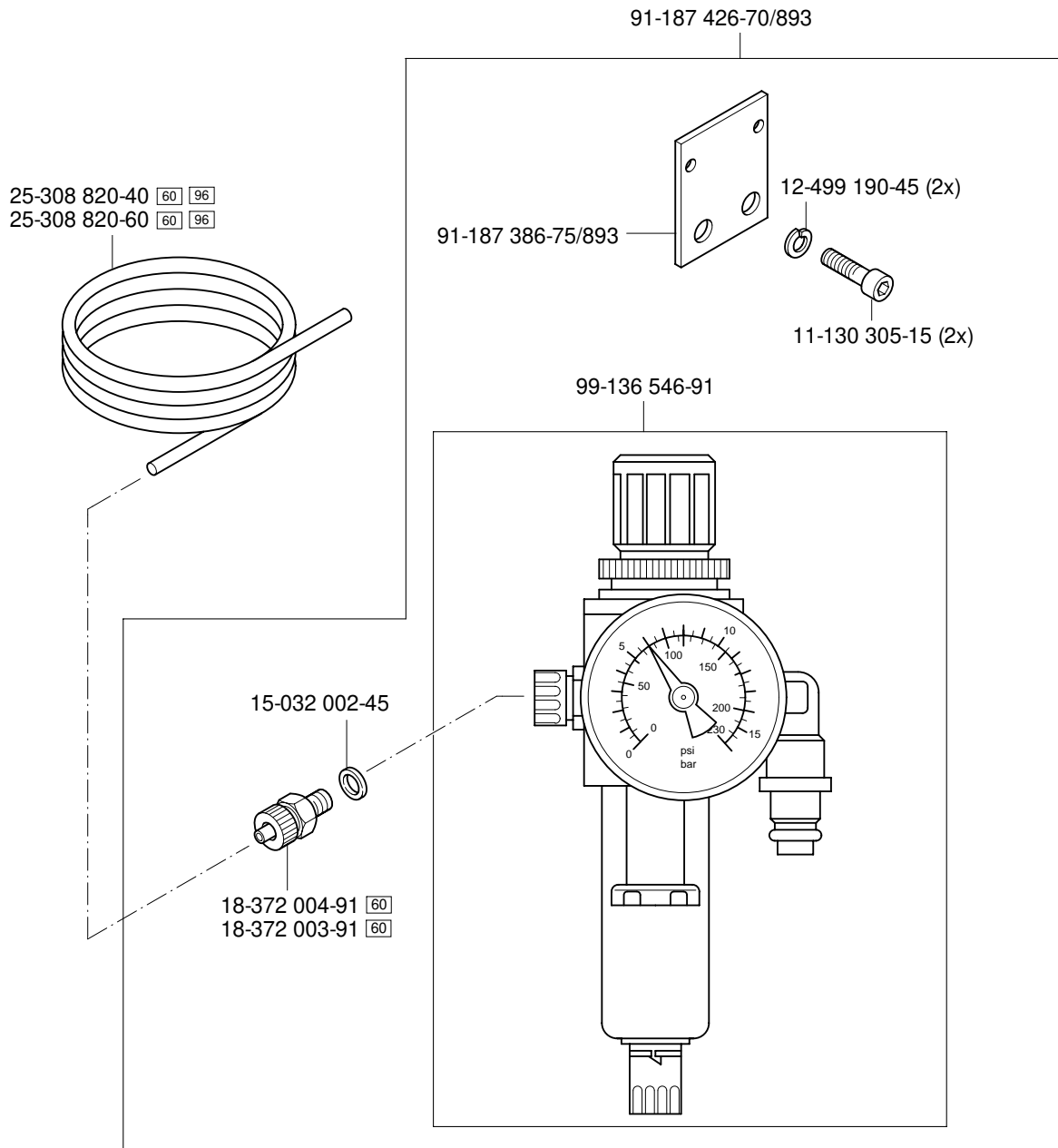

Spulensfadenvorratwächter (-926/06) PFAFF 1425  
 Bobbin thread supply monitor (-926/06) PFAFF 1426  
 Contrôleur de canette (-926/06) PFAFF 1426  
 Detector del hilo de la canilla (-926/06) PFAFF 3715

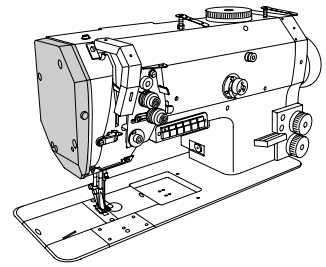

(PFAFF 1425; PFAFF 3715)

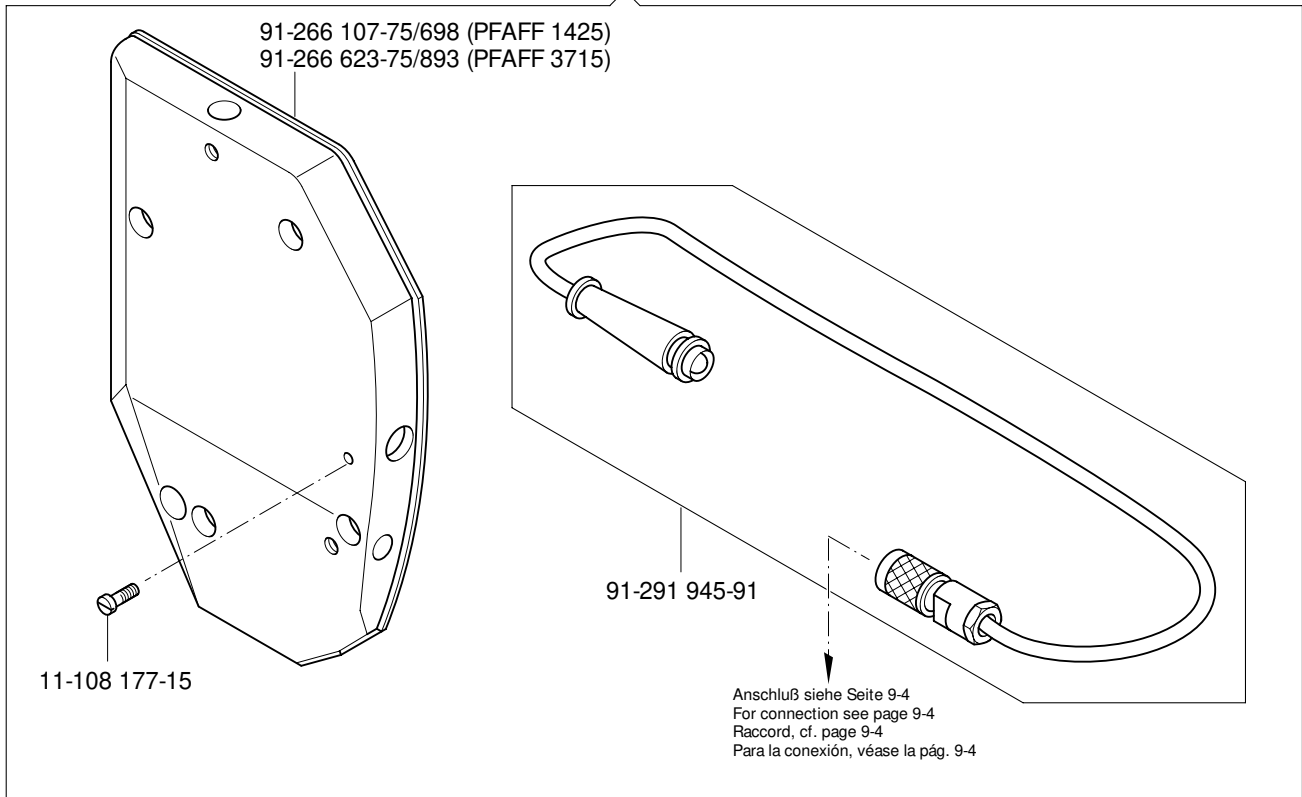

(PFAFF 1426)

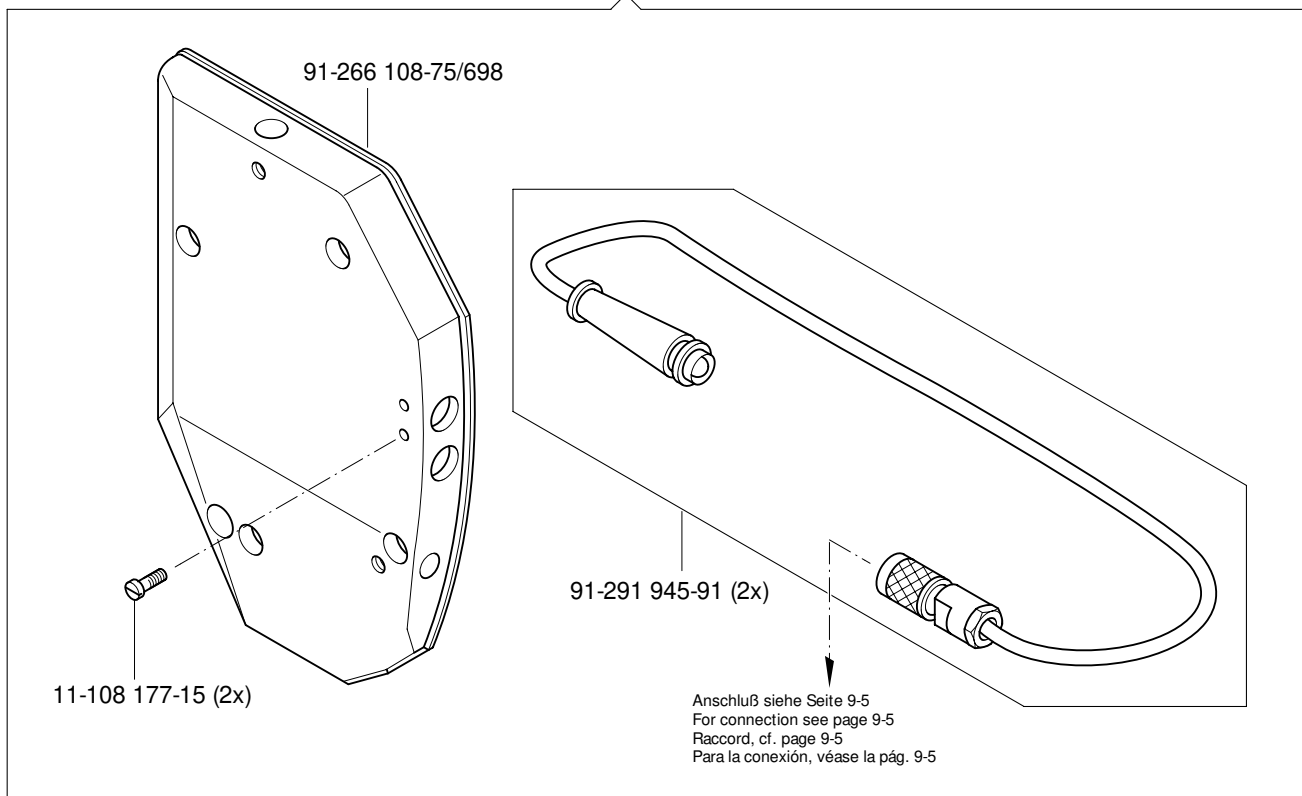



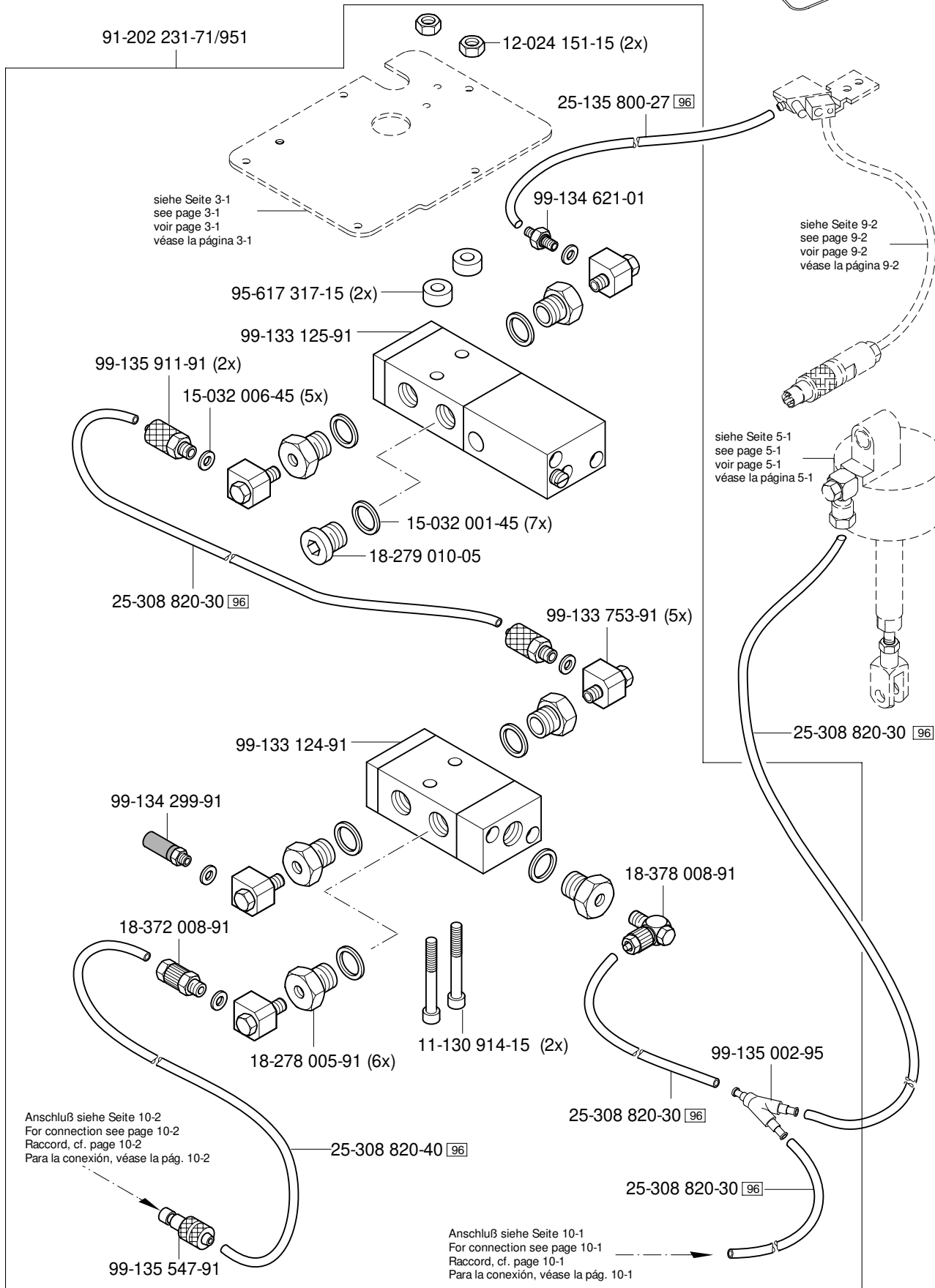
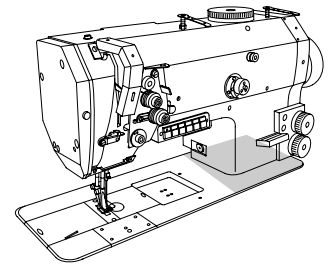



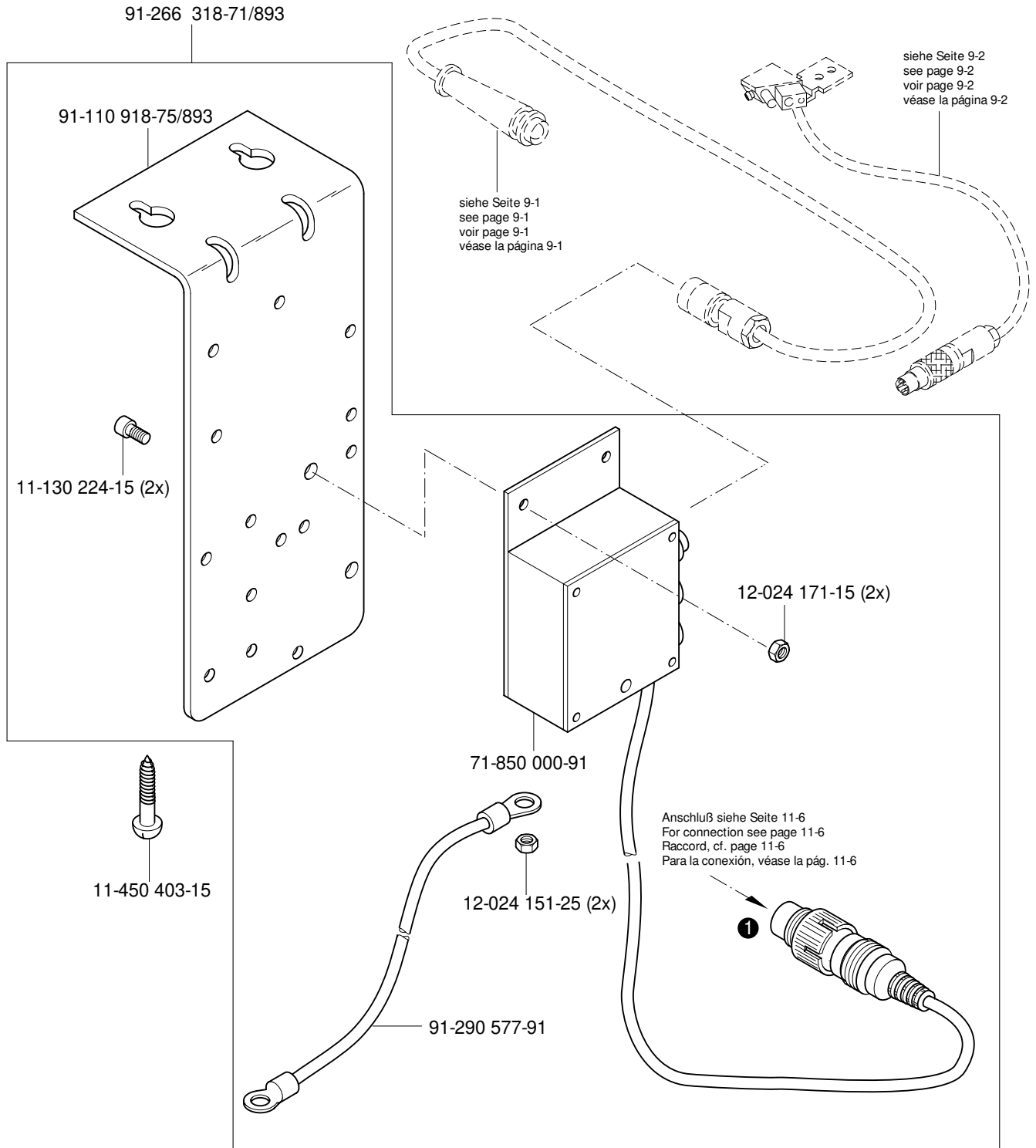

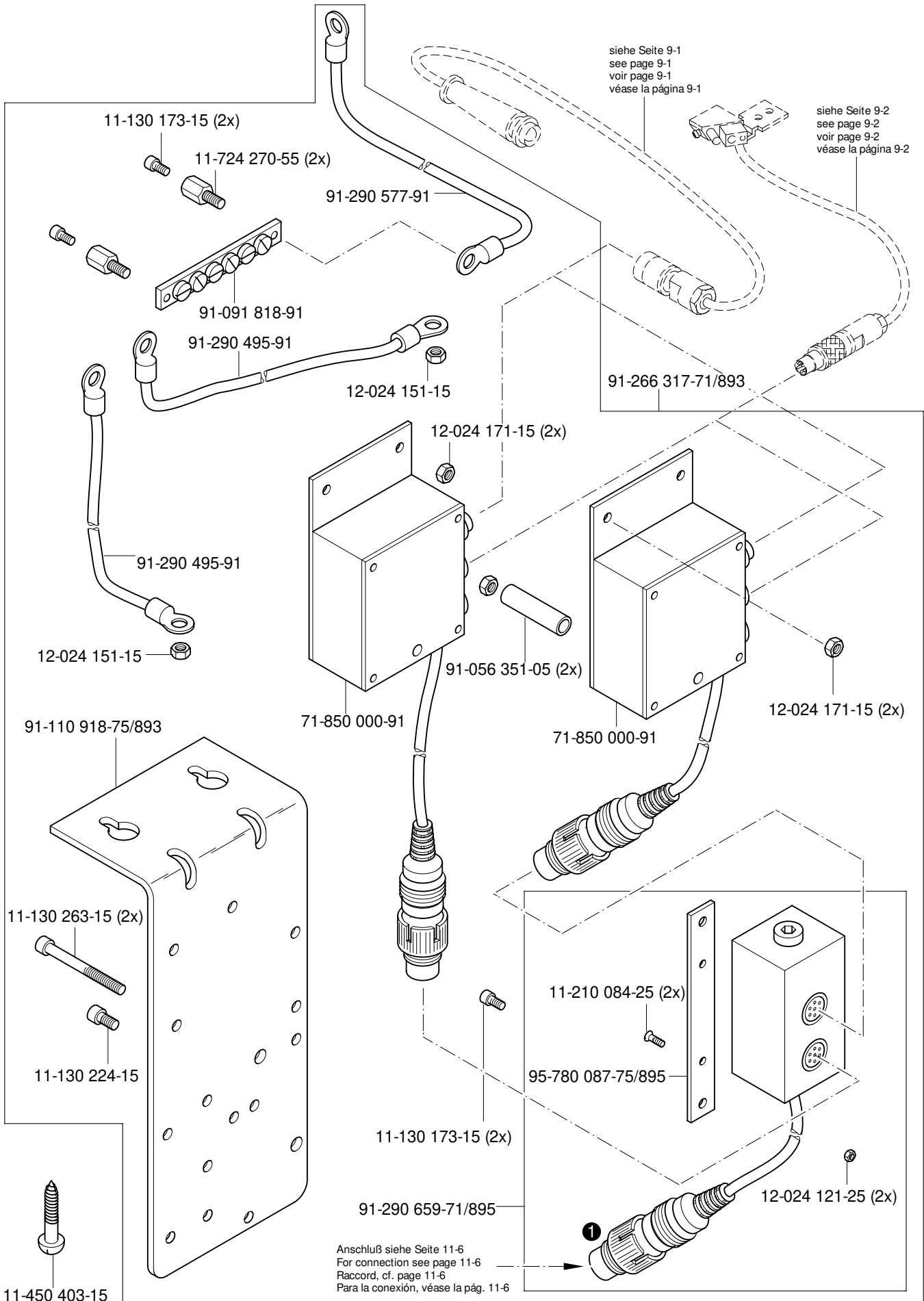

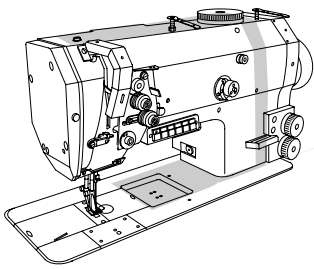

Pneumatische Ausrüstung  
 Pneumatic equipment  
 Equipement pneumatique  
 Equipo neumático

PFAFF 1425  
 PFAFF 1426  
 PFAFF 3715

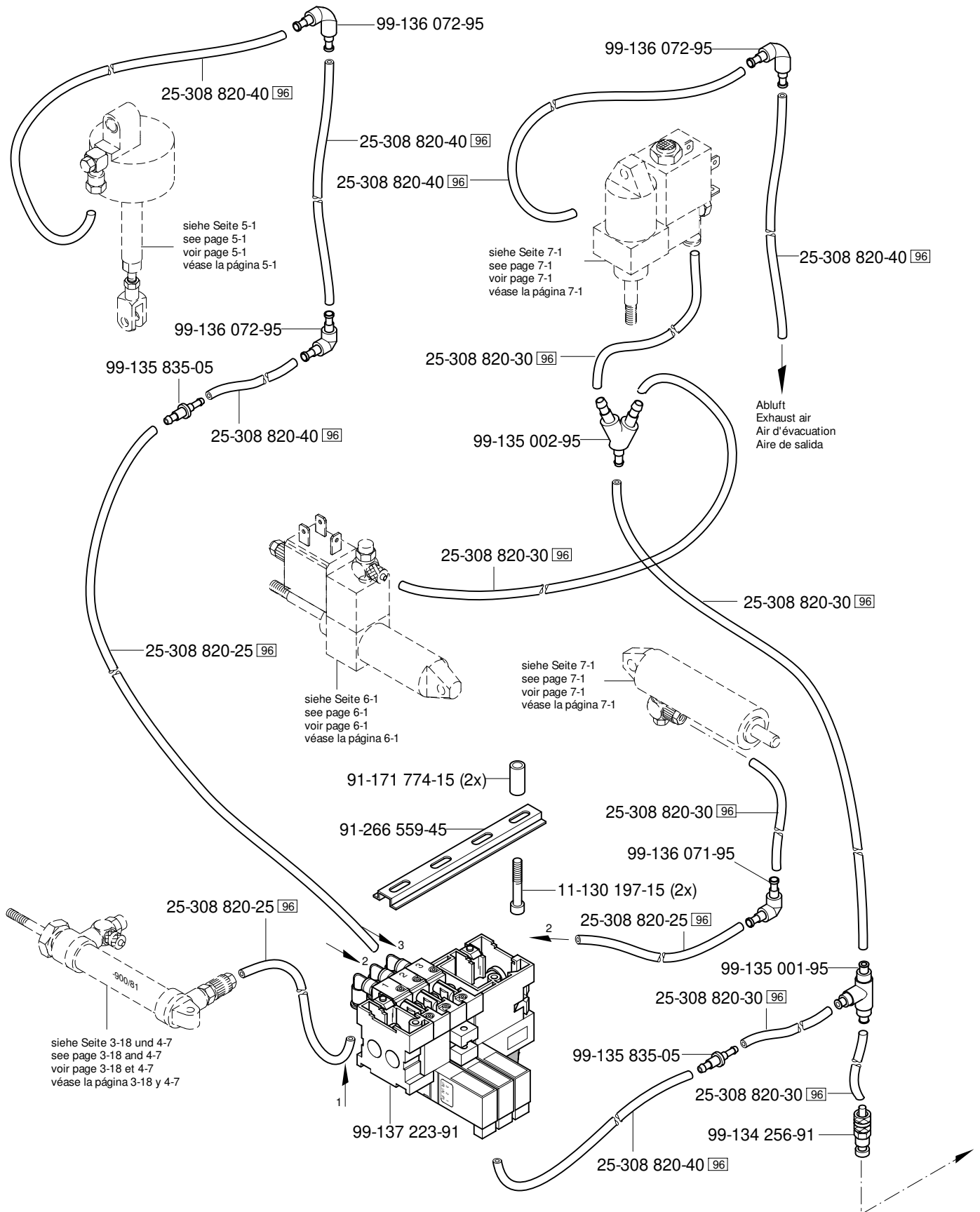

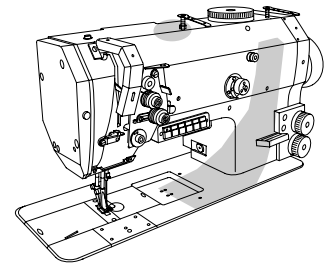

(-731/02)

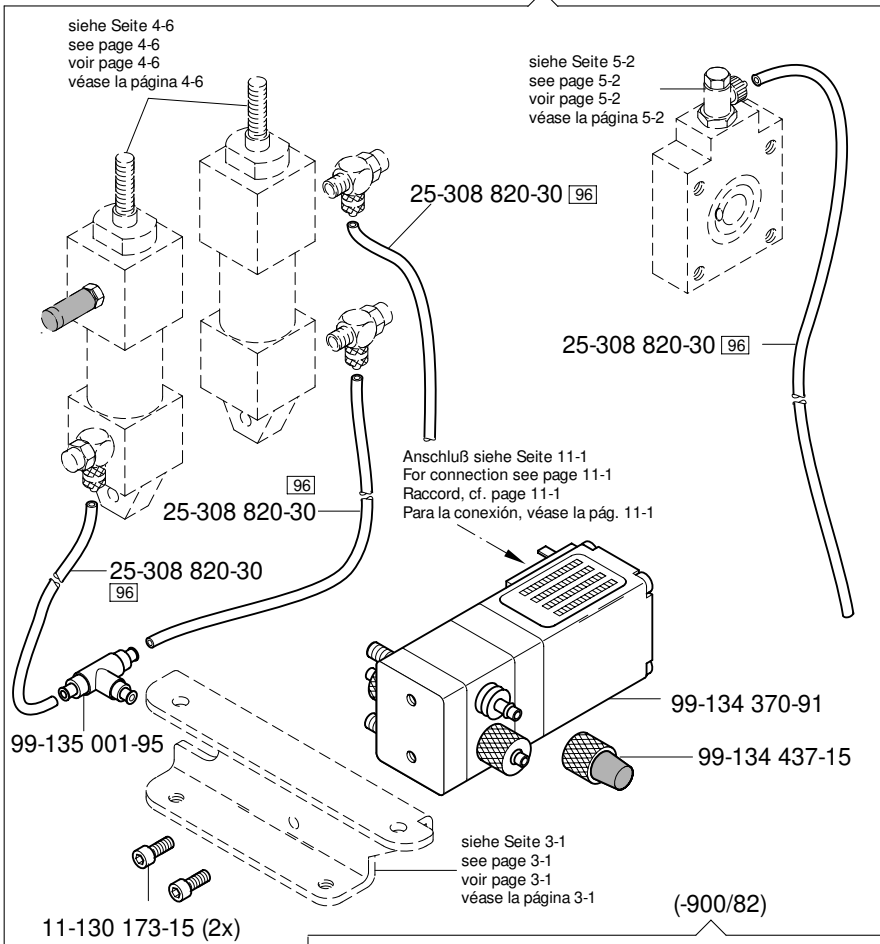

siehe Seite 4-3  
see page 4-3  
voir page 4-3  
véase la página 4-3

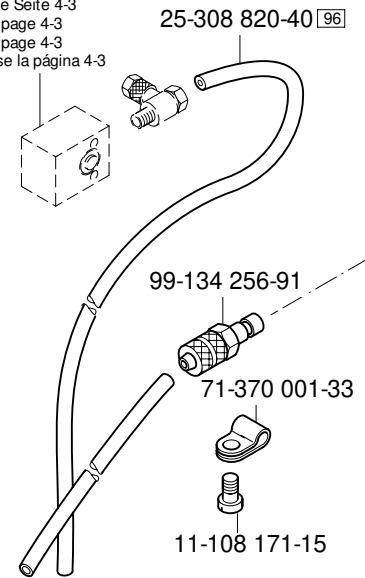

(-900/82)

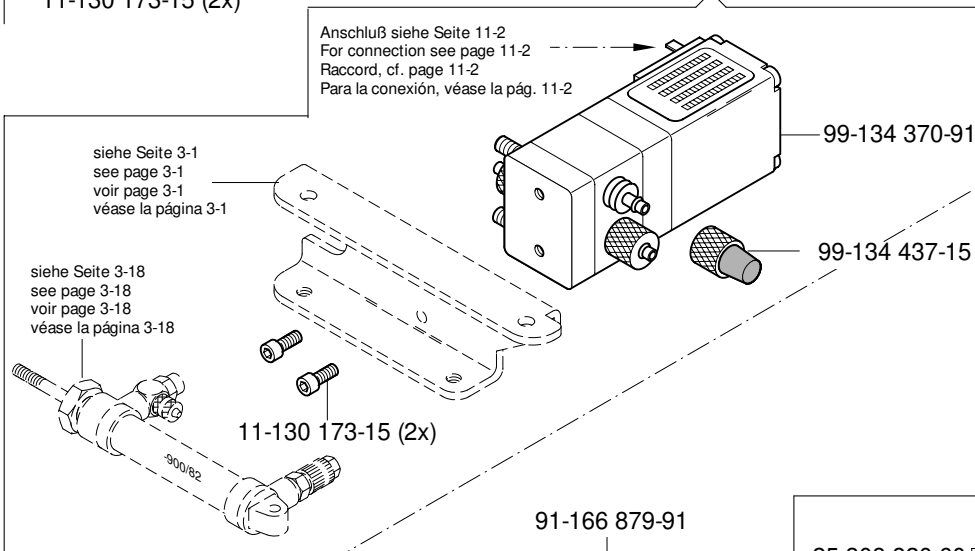

91-166 879-91

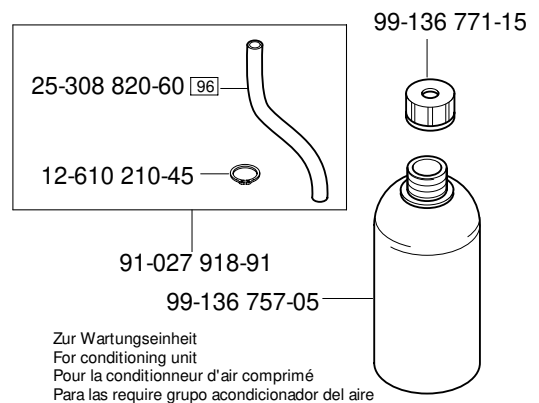
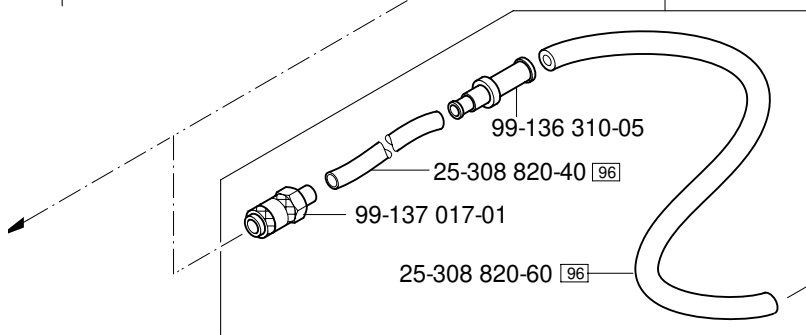

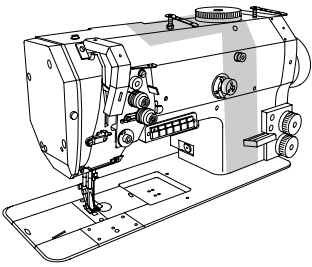

Kabelbaum zum Oberteil  
 Cable tree to sewing head  
 Faisceau de câbles vers la tête de machine  
 Mazo de cables para el cabezal

PFAFF 1425  
 PFAFF 1426  
 PFAFF 3715

11.01

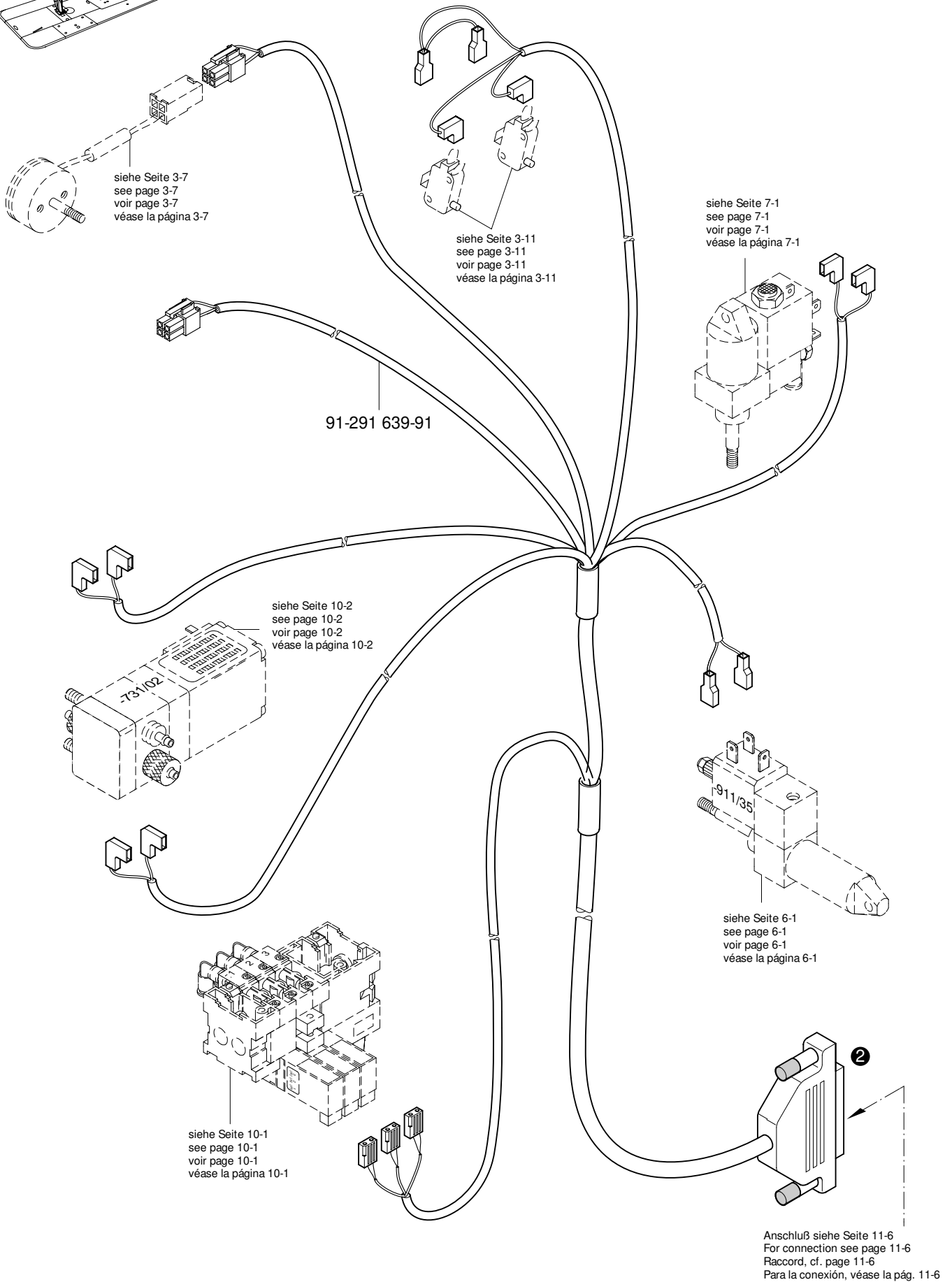

# 11.01

Kabelbaum zum Oberteil  
 Cable tree to sewing head  
 Faisceau de câbles vers la tête de machine  
 Mazo de cables para el cabezal

PFAFF 1425  
 PFAFF 1426  
 PFAFF 3715

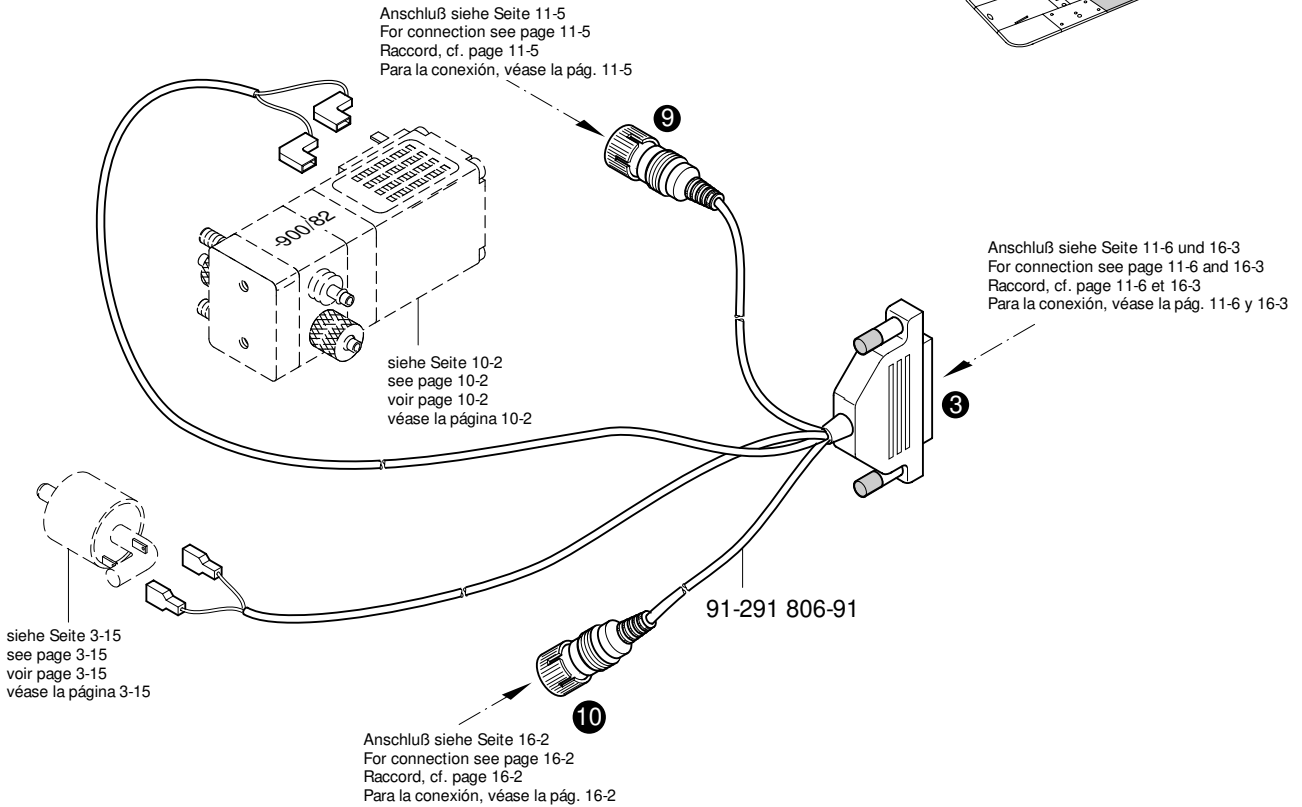
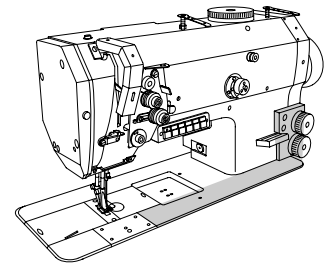

# 11.02

Tastenschalter  
 Push-button switch  
 Interrupteur à bouton-poussoir  
 Interruptor pulsador

PFAFF 1425  
 PFAFF 1426  
 PFAFF 3715

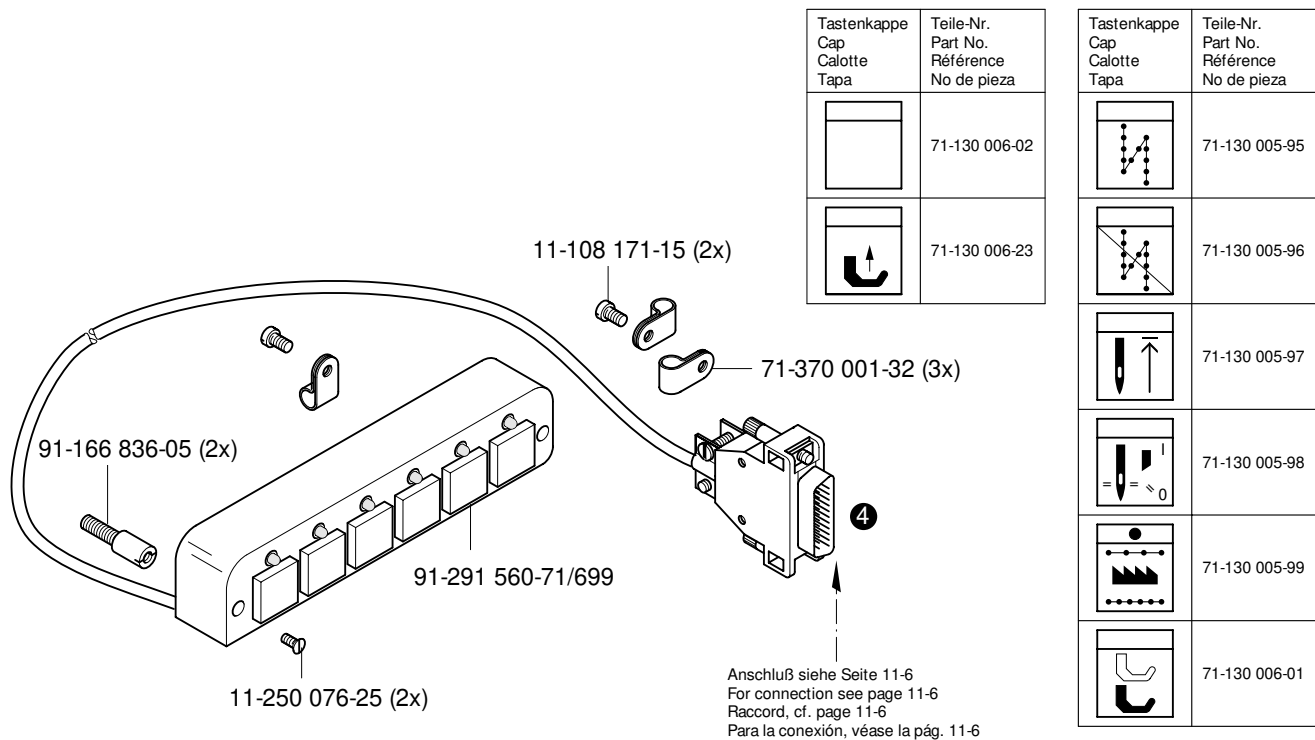
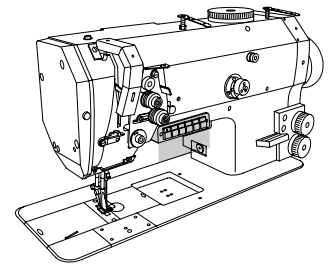

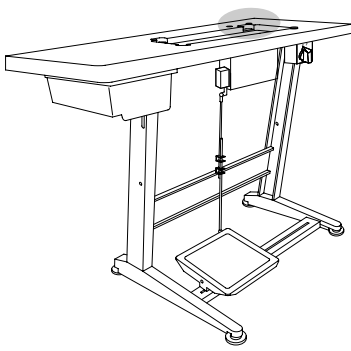

Bedienfeld  
 Control panel  
 Panneau de commande  
 Panel de mandos

PFAFF 1425  
 PFAFF 1426  
 PFAFF 3715

11.03

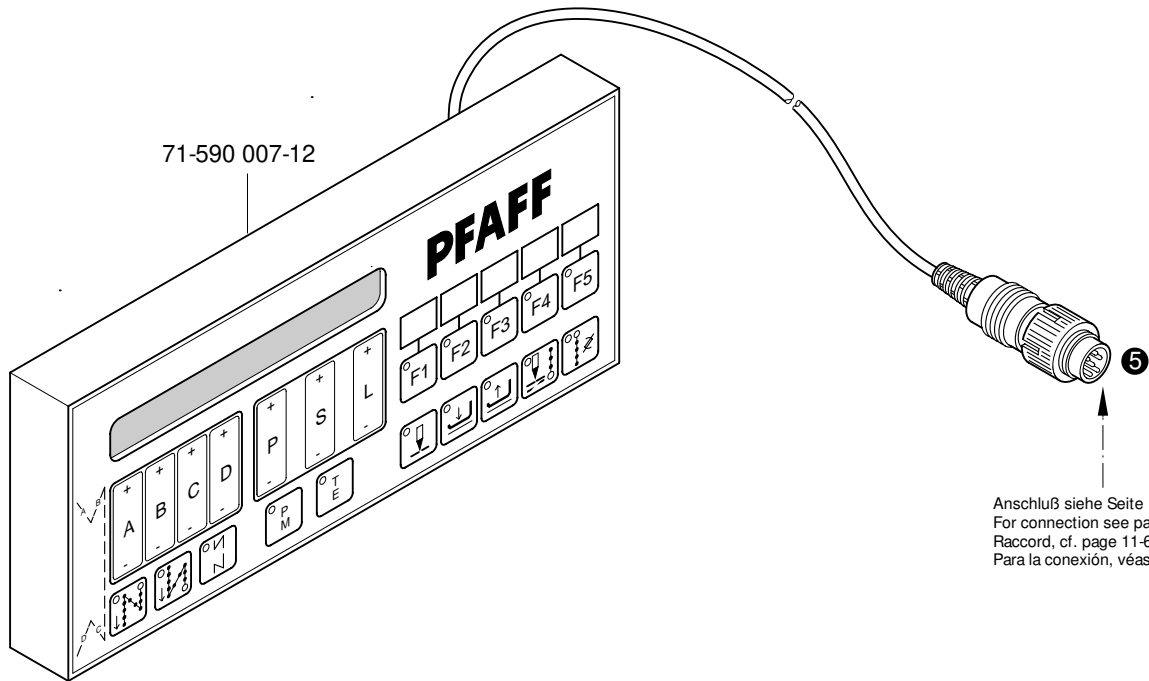

Anschluß siehe Seite 11-6  
 For connection see page 11-6  
 Raccord, cf. page 11-6  
 Para la conexión, véase la pág. 11-6



# 11.04

Positionsgeber  
Synchronizer PFAFF 1425  
Synchronisateur PFAFF 1426  
Sincronizador PFAFF 3715

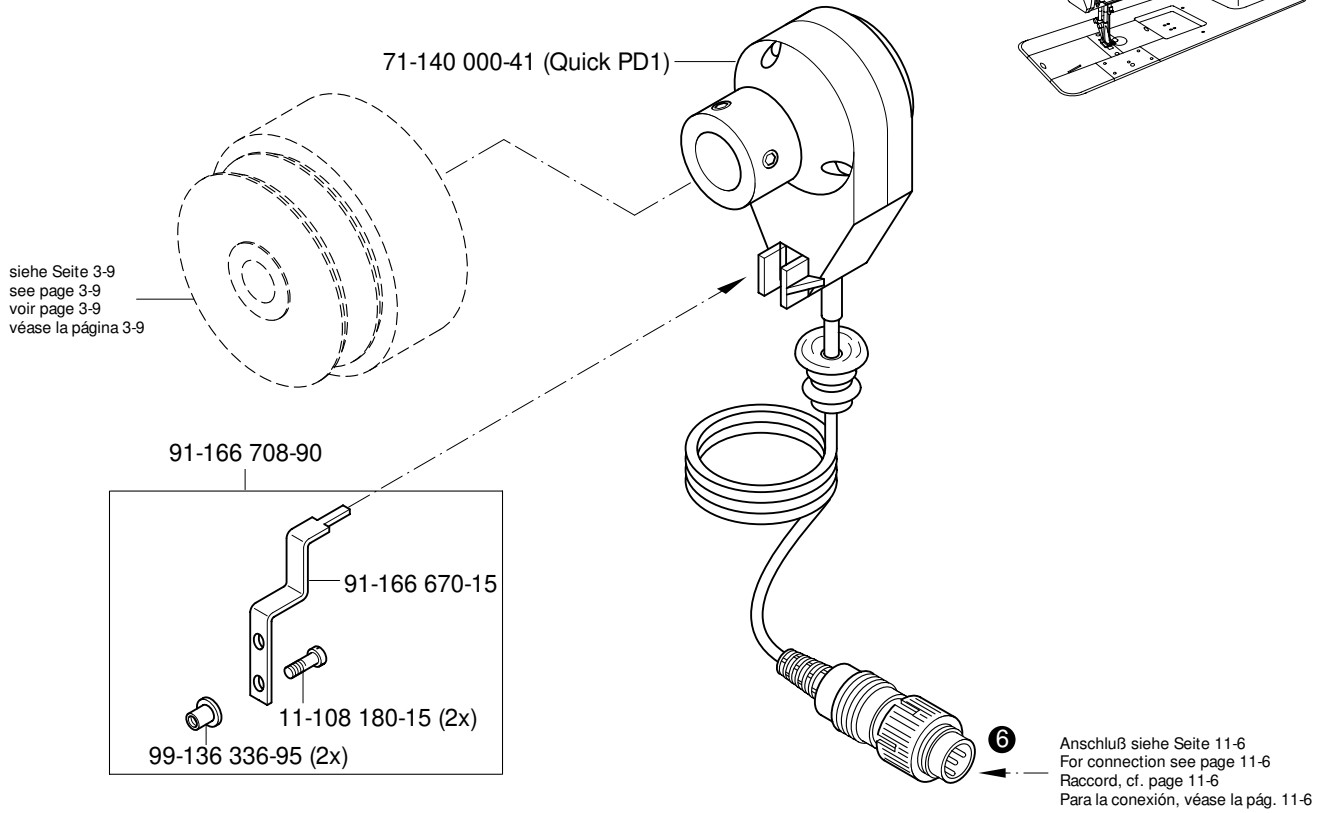
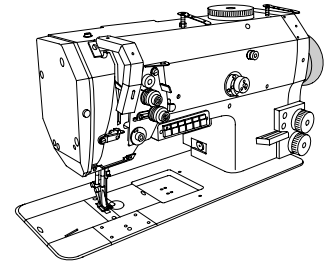

# 11.05

Sollwertgeber  
Set-point generator PFAFF 1425  
Codeur PFAFF 1426  
Emisor del valor teórico PFAFF 3715

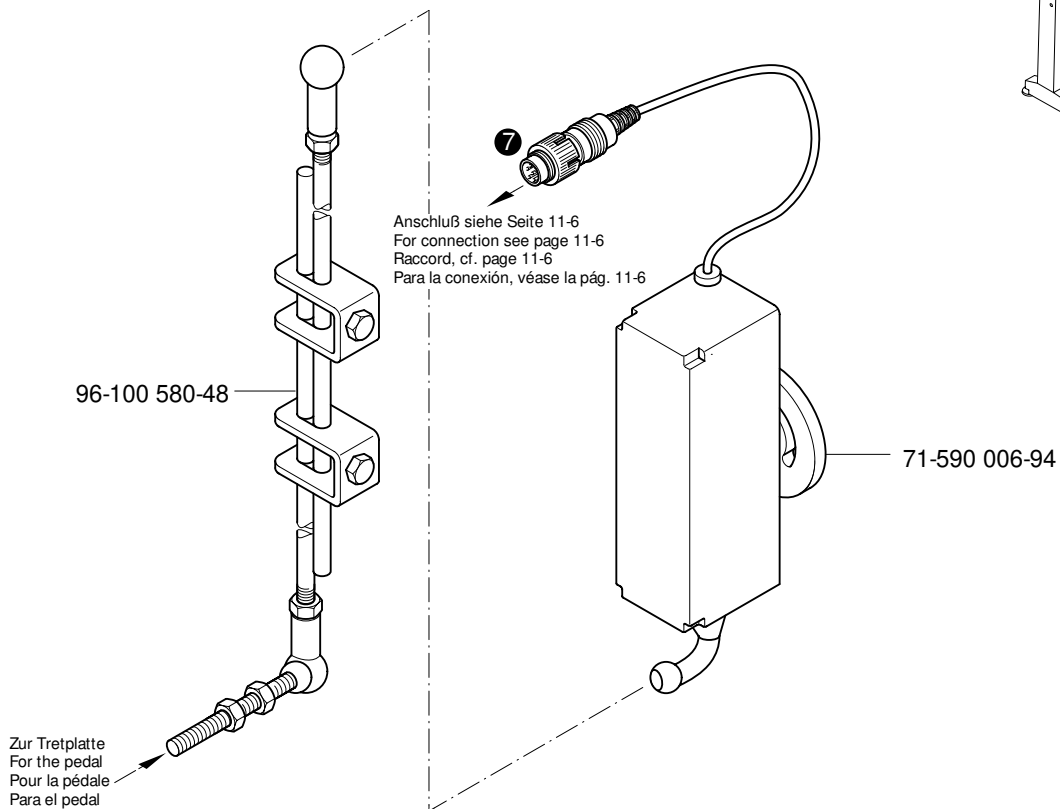
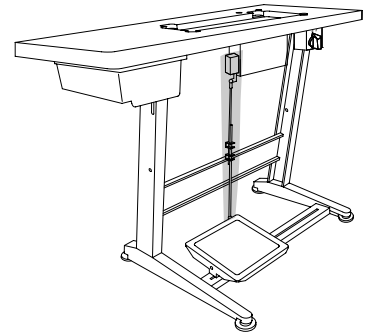



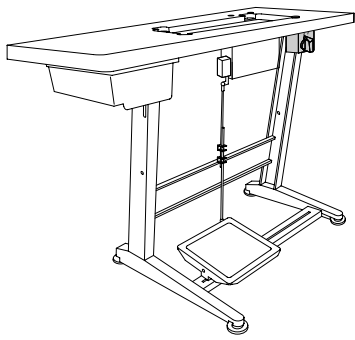

Motordrehschalter PFAFF 1425  
 Motor turn switch PFAFF 1426  
 Interrupteur rotatif PFAFF 1426  
 Interruttore giratorio PFAFF 3715

11.06

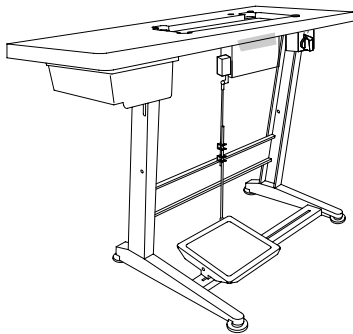
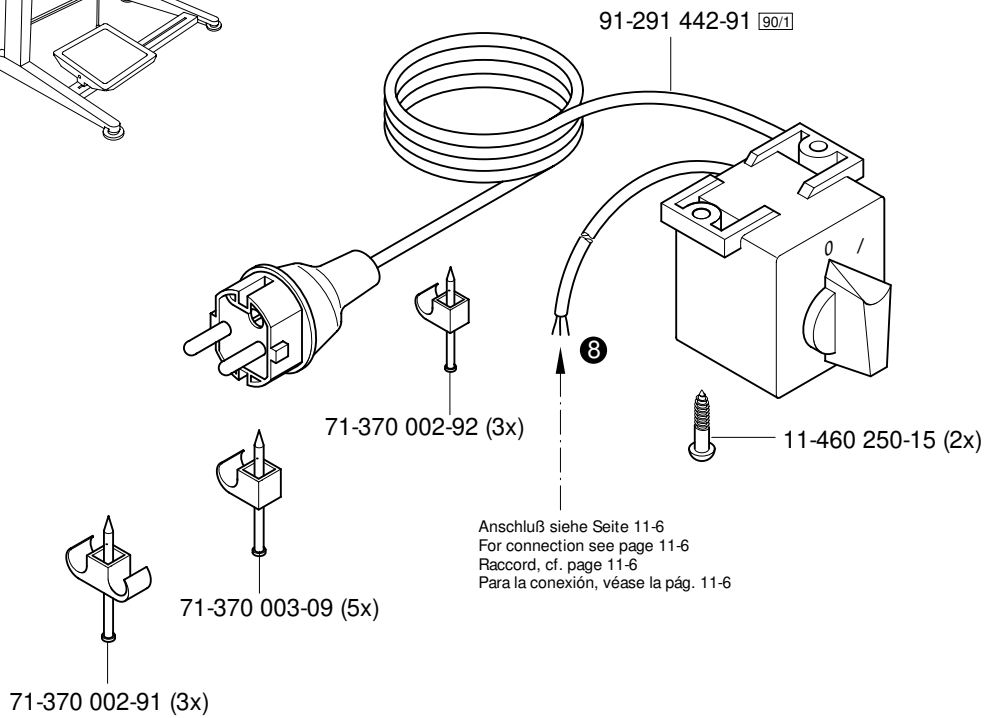

Knietaster mit Leitung PFAFF 1425  
 Knee switch with cable PFAFF 1426  
 Interrupteur de genouillère avec câble PFAFF 1426  
 Interruttore de rodillera con cable PFAFF 3715

11.07

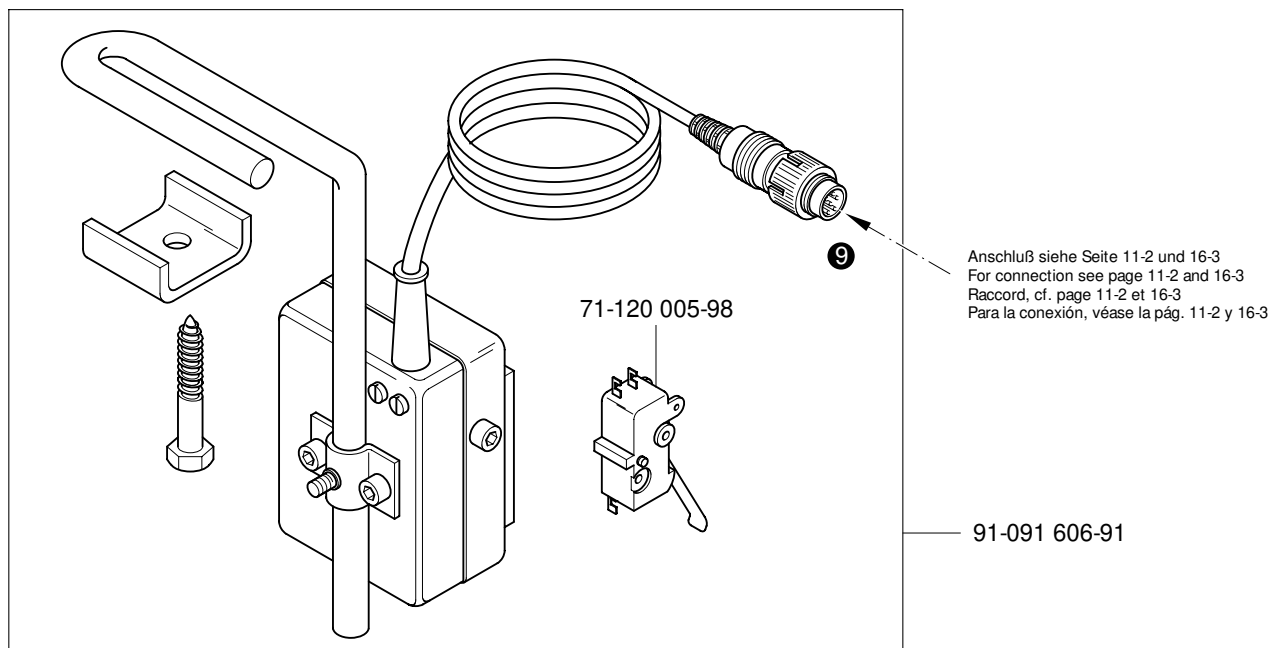

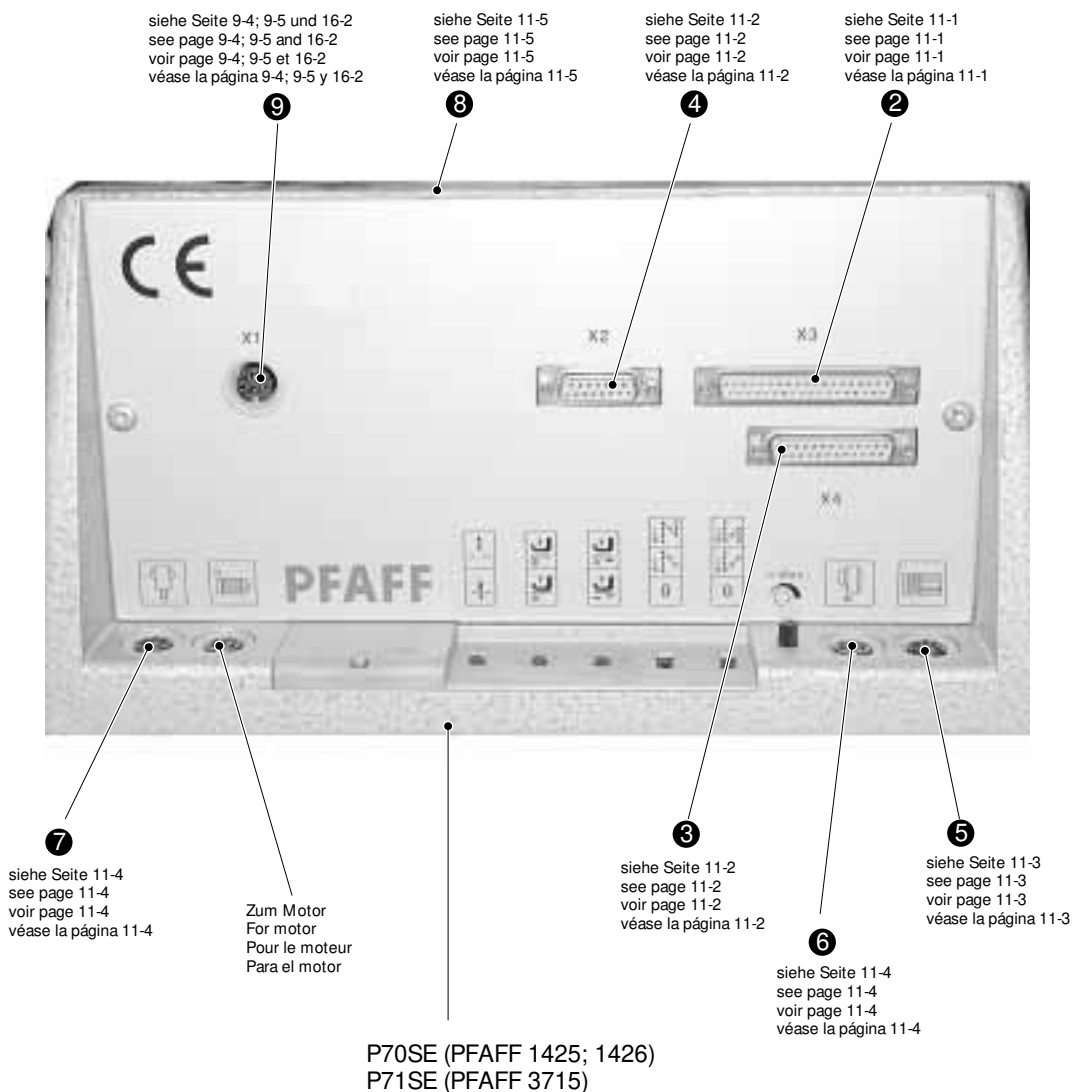
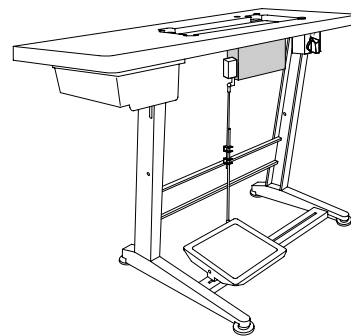

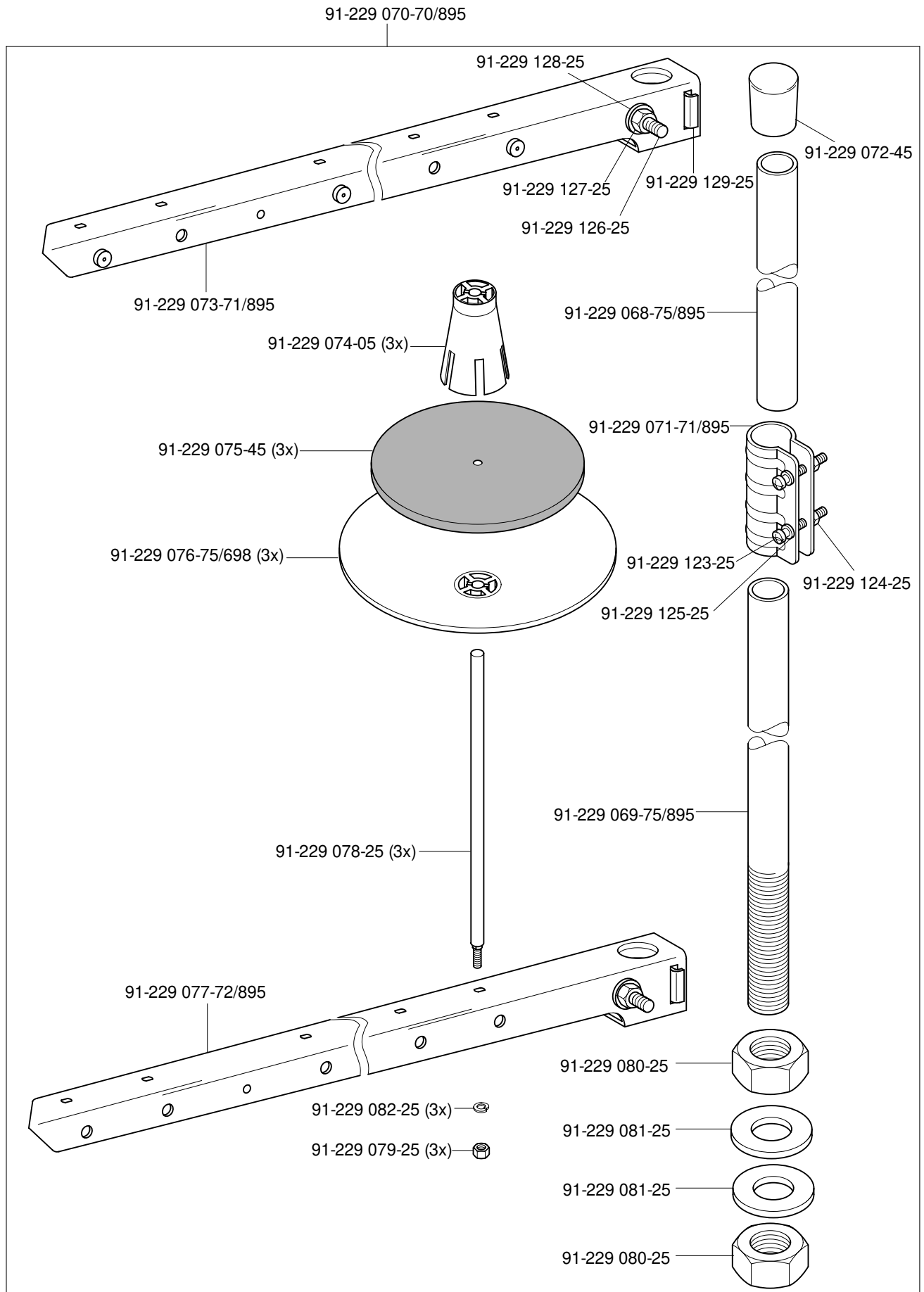

# 13

Einstellehren  
 Adjustment gauges PFAFF 1425  
 Calibres PFAFF 1426  
 Calibres de ajuste PFAFF 3715

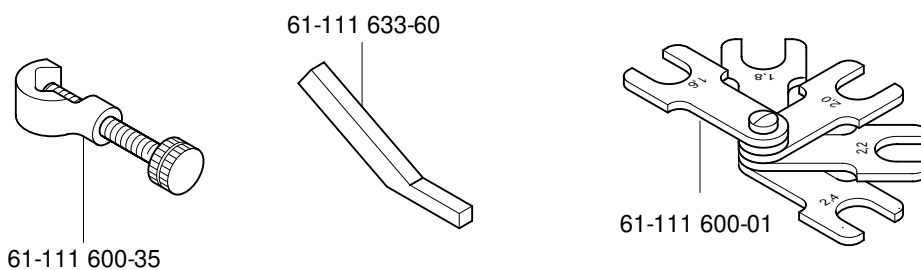

# 14

Teile zur Tischplatte  
 Parts for table top PFAFF 1425  
 Pièces du plateau PFAFF 1426  
 Piezas para el tablero PFAFF 3715

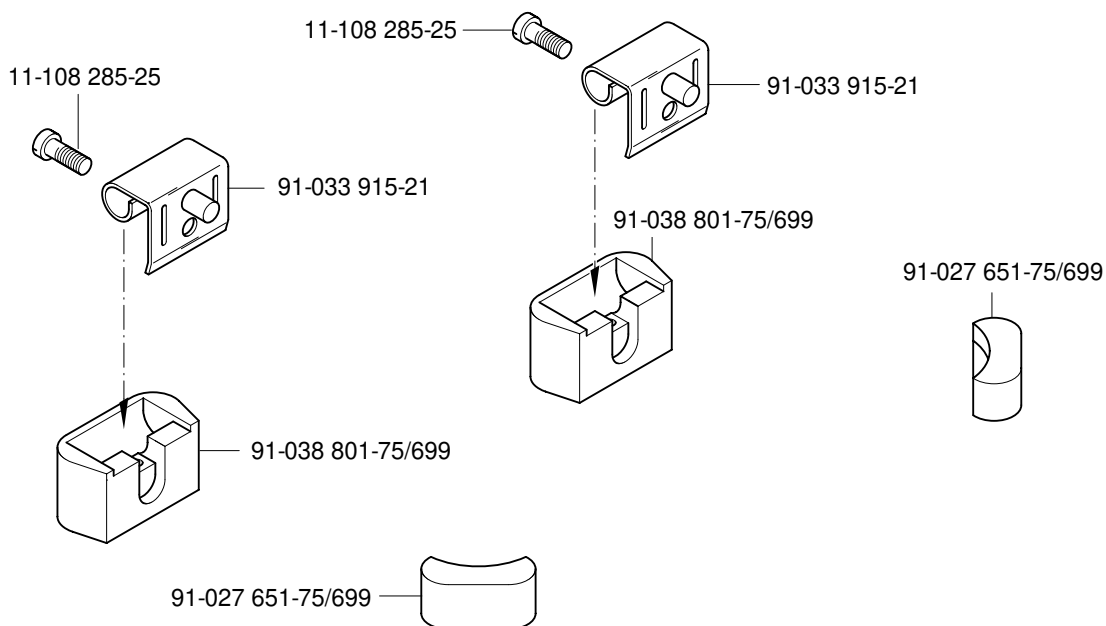

Keilriemen  
V-belt  
Courroie trapézoïdale  
Correa trapezoidal

PFAFF 1425  
PFAFF 1426  
PFAFF 3715

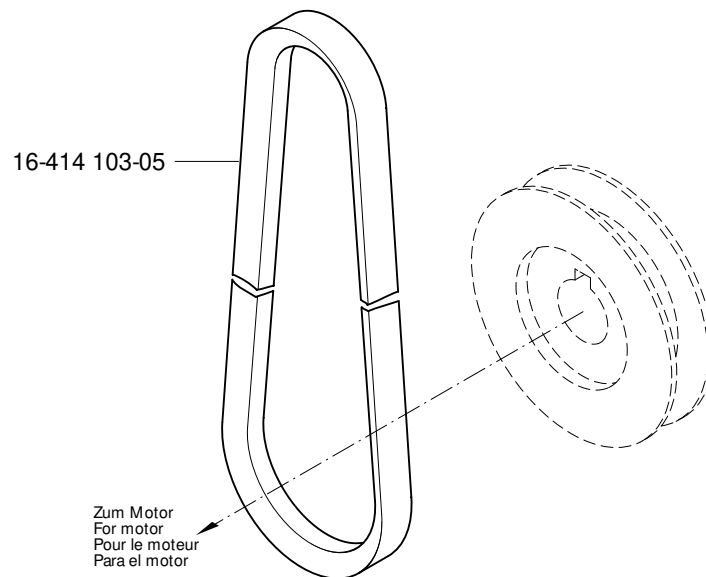

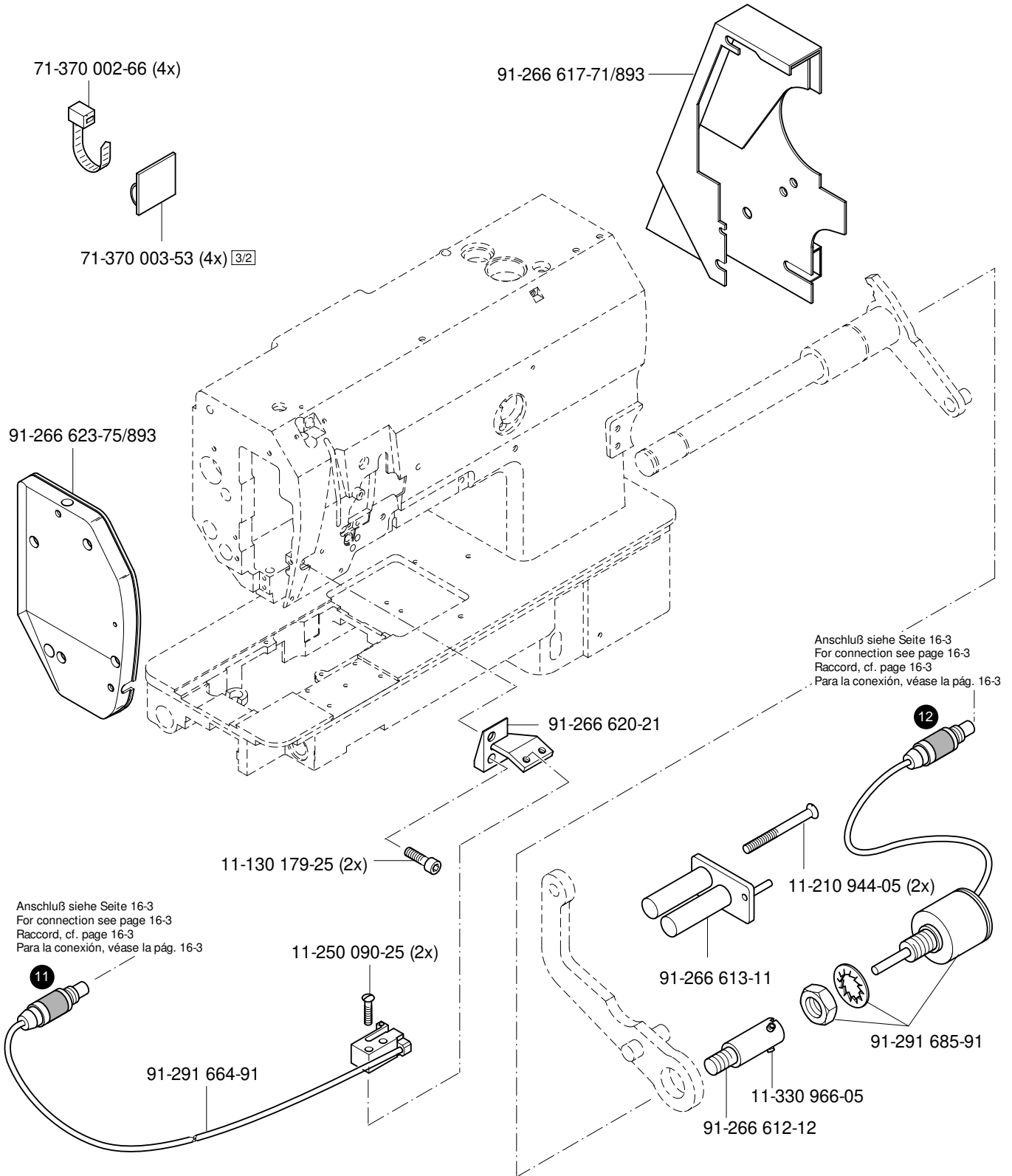
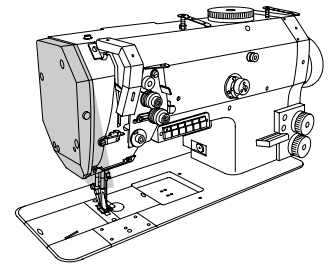

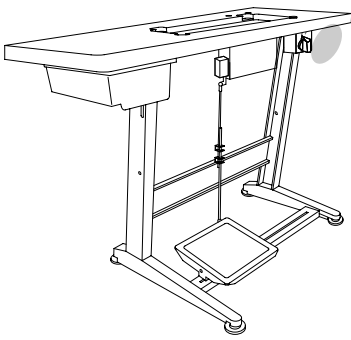

Teile zum Doku-Naht-System  
 Parts for the docu-seam system  
 Pièces du système de couture Doku  
 Piezas para el sistema de costura Doku

PFAFF 3715-2/01  
 PFAFF 3715-2/02

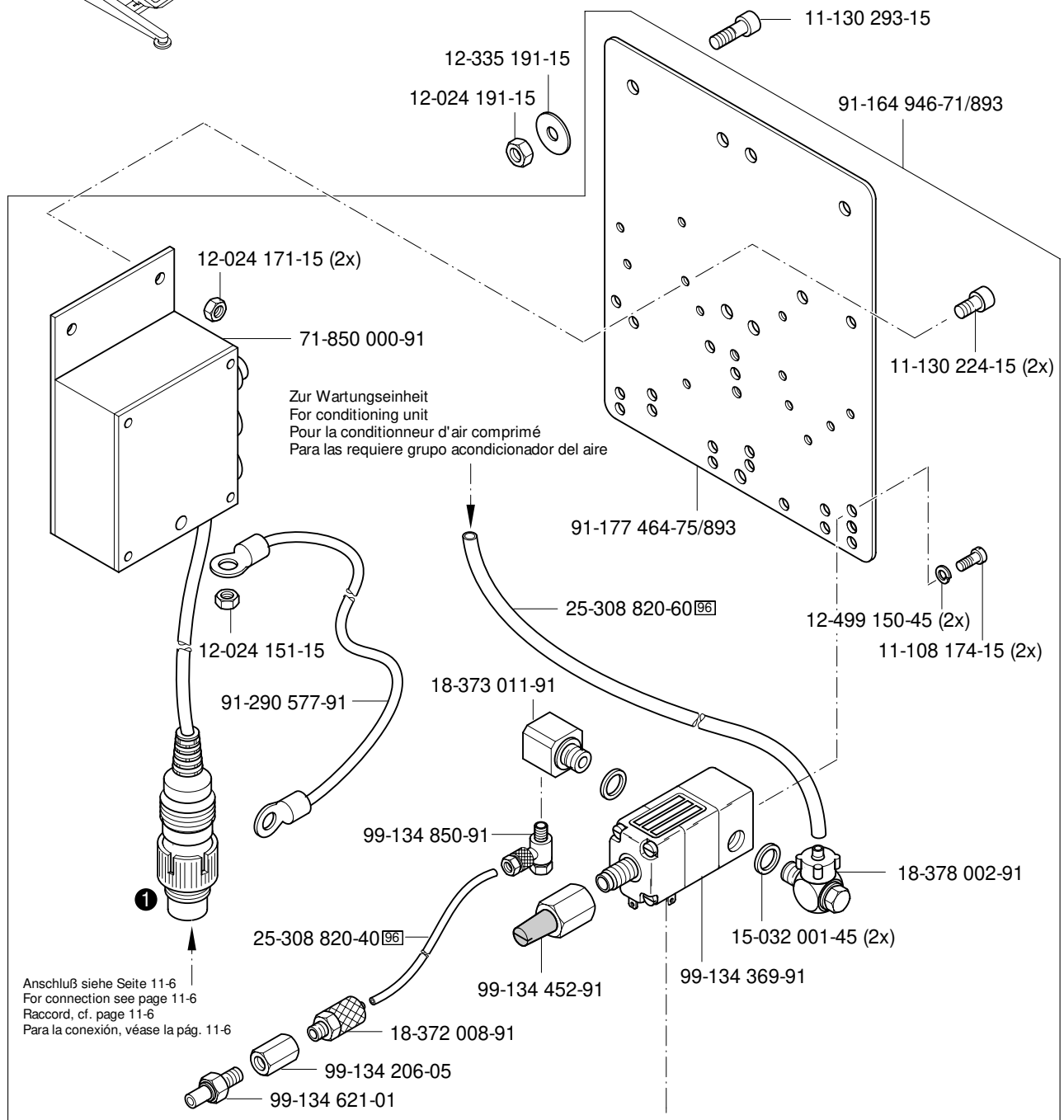

1  
 Anschluß siehe Seite 11-6  
 For connection see page 11-6  
 Raccord, cf. page 11-6  
 Para la conexión, véase la pág. 11-6

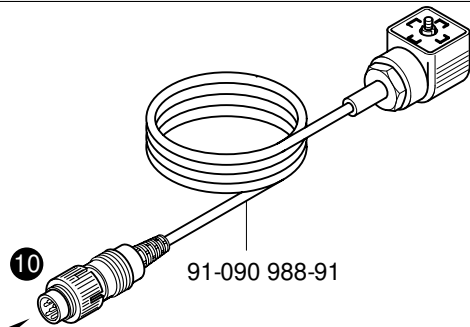

10  
 Anschluß siehe Seite 11-2  
 For connection see page 11-2  
 Raccord, cf. page 11-2  
 Para la conexión, véase la pág. 11-2

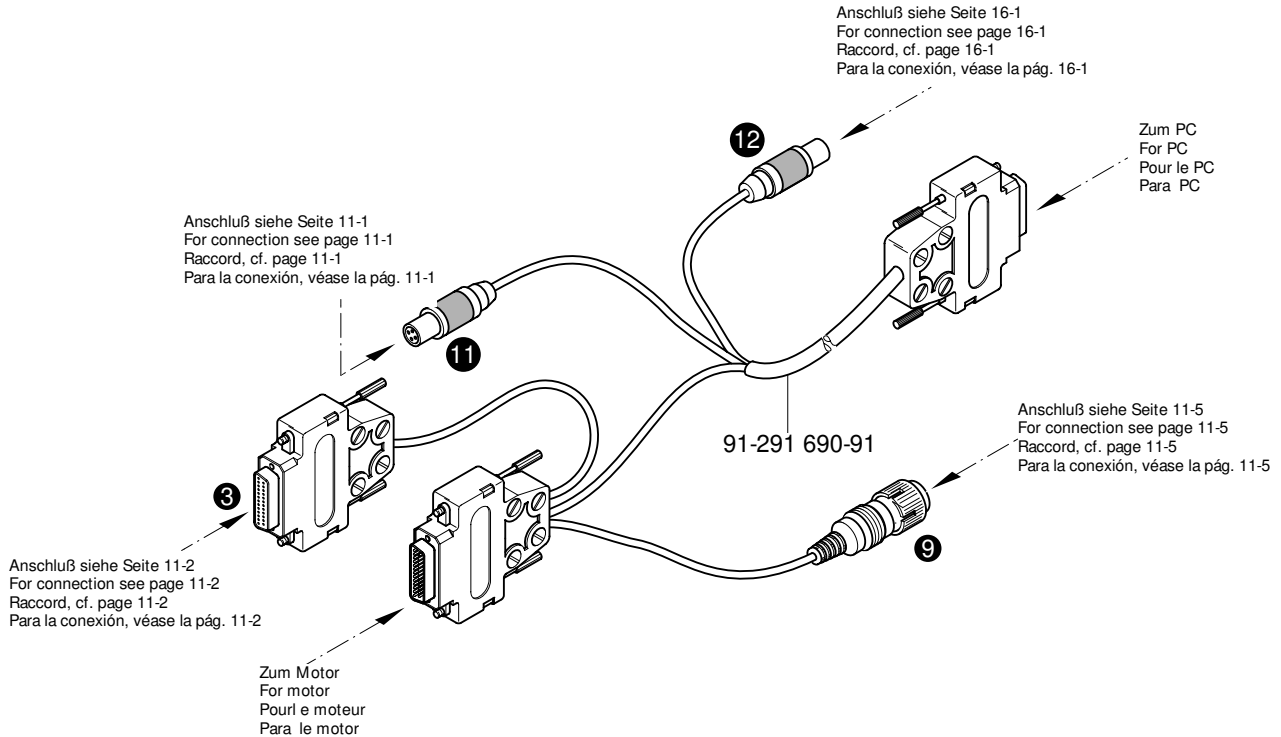
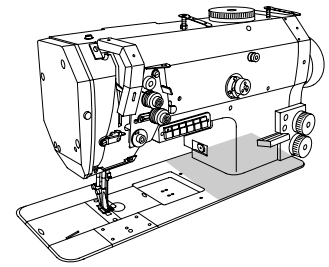

Einsteckkarten zum PC  
 Plug-in boards for the PC  
 Cartes de connection au PC  
 Tarjetas de inserción en el PC

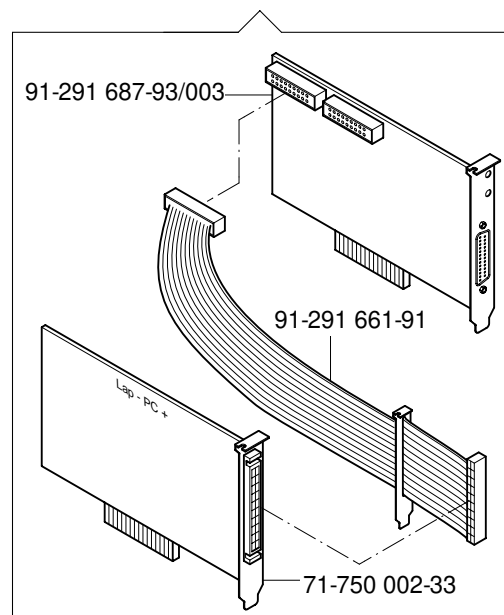



| Öl<br>Oil<br>Huile<br>Aceite | Mittelpunkts-Viskosität bei:<br>Mean viscosity at:<br>Viscosité moyenne à:<br>Viscosidad media a: |                    | Dichte bei:<br>Density of:<br>Densité à:<br>Densidad a: |                             | Bestellnummer für Behälter mit:<br>Part number for can with:<br>Numéro de commande pour récipients<br>avec:<br>Número de pedido para recipientes con: |                                |                                   |
|------------------------------|---|--------------------|---|-----------------------------|---|--------------------------------|-----------------------------------|
|                              | °C  | mm <sup>2</sup> /s | °C  | g/cm <sup>3</sup><br>(g/ml) | 1 Liter<br>1 Litre<br>1 Litro   | 5 Liter<br>5 Litre<br>5 Litros | 10 Liter<br>10 Litre<br>10 Litros |
| 28-011 20 1-44               | 40  | 22,0               | 15  | 0,865                       | 91-129 917-91   | 91-129 919-91                  | 91-129 920-91                     |
|                              |   |                    |   |                             |   |                                |                                   |
|                              |   |                    |   |                             |   |                                |                                   |
|                              |   |                    |   |                             |   |                                |                                   |

| Fett<br>Grease<br>Graisse<br>Grasa | Penetration<br>Penetration<br>Pénétration<br>Penetración | Tropfpunkt<br>Drip-point<br>Point de suintement<br>Punto de goteo | Bestellnummer für Behälter mit:<br>Part number for can with:<br>Numéro de commande pour récipients avec:<br>Número de pedido para recipientes con: |    |         |               |               |
|------------------------------------|--|---|--|----|---------|---------------|---------------|
|                                    |  |   | mm/10  | °C | 0,25 kg | 0,5 kg        | 1 kg          |
| 28-011 202-05                      |  |   |  |    |         |               | 28-011 202-05 |
| 28-011 202-43                      | 375-405  | 150   |  |    |         | 28-011 202-43 |               |
| 28-011 202-47                      | 220-250  | 185   |  |    |         |               | 28-011 202-47 |
|                                    |  |   |  |    |         |               |               |

| Reinigungsmittel<br>Cleansing agent<br>Agents de nettoyage<br>Limpiadores | Bestellnummer für Behälter mit:<br>Part number for can with:<br>Numéro de commande pour récipients avec:<br>Número de pedido para recipientes con: |  |  |
|---|--|--|--|
|   | 240 ml   |  |  |
| Isoprophyl-Alkohol  | 95-665 735-91  |  |  |

| No.           | Seite<br>Page<br>Pages<br>Página            | No.           | Seite<br>Page<br>Pages<br>Página                            | No.           | Seite<br>Page<br>Pages<br>Página   | No.           | Seite<br>Page<br>Pages<br>Página                  |
|---------------|---|---------------|---|---------------|--|---------------|---|
| 11-039 096-15 | 4 - 4                                       | 11-130 179-25 | 16 - 1  | 11-210 084-25 | 9 - 5  | 11-335 280-15 | 3 - 3, 3 - 9,<br>3 - 22                           |
| 11-039 222-15 | 4 - 4                                       | 11-130 191-15 | 3 - 11  | 11-210 168-15 | 3 - 21   | 11-335 902-15 | 3 - 9, 3 - 21                                     |
| 11-039 225-15 | 3 - 6                                       | 11-130 197-15 | 10 - 1  | 11-210 168-25 | 3 - 7, 3 - 10  | 11-341 166-15 | 3 - 3, 3 - 13,<br>3 - 18, 3 - 19,<br>4 - 7        |
| 11-039 306-15 | 3 - 18, 3 - 19                              | 11-130 224-15 | 3 - 9, 3 - 14,<br>3 - 22, 9 - 4,<br>9 - 5, 16 - 2           | 11-210 174-15 | 3 - 17   | 11-341 217-15 | 3 - 3   |
| 11-106 923-25 | 4 - 3                                       | 11-130 227-25 | 4 - 4   | 11-210 210-15 | 3 - 18, 3 - 19,<br>4 - 7   | 11-341 280-15 | 4 - 4   |
| 11-108 090-15 | 3 - 11                                      | 11-130 233-15 | 3 - 1, 3 - 11,<br>3 - 22                                    | 11-210 295-15 | 3 - 9  | 11-341 901-15 | 3 - 20  |
| 11-108 132-15 | 4 - 4                                       | 11-130 239-15 | 4 - 2   | 11-210 944-05 | 16 - 1   | 11-341 902-15 | 3 - 9, 3 - 22,<br>4 - 3                           |
| 11-108 171-15 | 3 - 18, 3 - 19,<br>4 - 7, 10 - 2,<br>11 - 2 | 11-130 239-15 | 3 - 1   | 11-225 175-15 | 3 - 21   | 11-341 904-15 | 3 - 2, 3 - 3,<br>4 - 2, 5 - 1                     |
| 11-108 171-25 | 3 - 14                                      | 11-130 245-15 | 4 - 6   | 11-225 184-15 | 3 - 17, 9 - 2  | 11-341 905-15 | 3 - 9, 3 - 16,<br>3 - 18, 3 - 19,<br>4 - 5, 4 - 7 |
| 11-108 174-15 | 3 - 4, 3 - 5,<br>3 - 14, 3 - 18,<br>16 - 2  | 11-130 254-15 | 5 - 1   | 11-225 220-15 | 3 - 1, 3 - 11  | 11-347 301-15 | 3 - 13  |
| 11-108 177-15 | 9 - 1                                       | 11-130 263-15 | 9 - 5   | 11-225 304-15 | 3 - 13   | 11-450 403-15 | 9 - 4, 9 - 5                                      |
| 11-108 180-15 | 11 - 4                                      | 11-130 287-15 | 3 - 3, 3 - 18,<br>3 - 19, 4 - 7,<br>5 - 1                   | 11-250 076-25 | 11 - 2   | 11-460 250-15 | 11 - 5  |
| 11-108 192-15 | 3 - 17                                      | 11-130 293-15 | 3 - 2, 3 - 12,<br>3 - 21, 4 - 2,<br>4 - 4, 5 - 1,<br>16 - 2 | 11-250 084-25 | 3 - 10   | 11-462 118-55 | 3 - 1   |
| 11-108 207-25 | 3 - 15                                      | 11-130 293-15 | 3 - 2, 3 - 12,<br>3 - 21, 4 - 2,<br>4 - 4, 5 - 1,<br>16 - 2 | 11-250 090-25 | 16 - 1   | 11-706 169-05 | 3 - 4, 3 - 5                                      |
| 11-108 222-25 | 4 - 1                                       | 11-130 305-15 | 8 - 1   | 11-314 946-15 | 3 - 8  | 11-713 010-91 | 3 - 11  |
| 11-108 225-25 | 3 - 1, 4 - 1                                | 11-130 311-15 | 3 - 19  | 11-317 949-15 | 3 - 4, 3 - 5   | 11-724 270-55 | 9 - 5   |
| 11-108 228-25 | 3 - 1                                       | 11-130 311-15 | 3 - 19  | 11-317 950-15 | 3 - 18, 3 - 19,<br>4 - 7   | 12-005 154-25 | 3 - 7, 3 - 8                                      |
| 11-108 246-25 | 3 - 1                                       | 11-130 906-15 | 3 - 1   | 11-330 082-15 | 3 - 5  | 12-005 171-15 | 3 - 18, 4 - 7                                     |
| 11-108 255-25 | 4 - 1                                       | 11-130 911-15 | 3 - 11  | 11-330 166-15 | 3 - 6, 4 - 5   | 12-005 175-15 | 3 - 11, 7 - 1                                     |
| 11-108 258-25 | 3 - 1                                       | 11-130 914-15 | 9 - 3   | 11-330 169-15 | 3 - 7, 3 - 8   | 12-005 175-15 | 3 - 11, 7 - 1                                     |
| 11-108 258-25 | 3 - 1                                       | 11-132 172-15 | 3 - 18, 3 - 19,<br>4 - 7                                    | 11-330 172-15 | 4 - 6  | 12-005 195-15 | 3 - 11, 3 - 12,<br>3 - 19                         |
| 11-108 285-15 | 3 - 1, 3 - 18                               | 11-132 223-15 | 3 - 1, 3 - 12,<br>3 - 16                                    | 11-330 175-15 | 3 - 18   | 12-024 121-15 | 4 - 4   |
| 11-108 285-25 | 13 - 1                                      | 11-132 223-15 | 3 - 1, 3 - 12,<br>3 - 16                                    | 11-330 217-15 | 3 - 18, 3 - 19,<br>4 - 7   | 12-024 121-25 | 9 - 5   |
| 11-108 846-15 | 3 - 3                                       | 11-132 292-15 | 3 - 3   | 11-330 217-15 | 3 - 18, 3 - 19,<br>4 - 7   | 12-024 151-15 | 3 - 18, 9 - 3,<br>9 - 5, 16 - 2                   |
| 11-108 852-15 | 3 - 4                                       | 11-132 298-15 | 4 - 5   | 11-330 220-15 | 3 - 6, 3 - 11  | 12-024 151-25 | 9 - 4   |
| 11-130 089-15 | 3 - 2, 3 - 8                                | 11-172 127-25 | 3 - 7, 3 - 8  | 11-330 223-15 | 3 - 7, 3 - 22,<br>4 - 3, 4 - 5   | 12-024 171-15 | 3 - 19, 4 - 6,<br>6 - 1, 9 - 4,<br>9 - 5, 16 - 2  |
| 11-130 092-15 | 3 - 17, 9 - 2                               | 11-173 174-25 | 3 - 3   | 11-330 280-15 | 3 - 9, 3 - 11,<br>3 - 22   | 12-024 191-15 | 3 - 13, 3 - 19,<br>3 - 21, 5 - 1,<br>16 - 2       |
| 11-130 095-15 | 3 - 18                                      | 11-174 086-15 | 3 - 4   | 11-330 283-15 | 7 - 1  | 12-024 191-25 | 3 - 10  |
| 11-130 147-31 | 9 - 5                                       | 11-174 173-15 | 3 - 5   | 11-330 952-15 | 3 - 10, 3 - 13,<br>3 - 21, 3 - 22,<br>4 - 3  | 12-024 951-15 | 4 - 5   |
| 11-130 167-15 | 3 - 18, 3 - 19,<br>4 - 7                    | 11-178 233-25 | 3 - 11  | 11-330 960-15 | 3 - 3, 3 - 12,<br>3 - 18, 3 - 19,<br>3 - 21, 4 - 3,<br>4 - 4, 4 - 5,<br>4 - 7, 5 - 1 | 12-090 150-05 | 3 - 11  |
| 11-130 173-15 | 3 - 2, 3 - 18,<br>4 - 7, 9 - 5,<br>10 - 2   | 11-180 169-25 | 3 - 1, 3 - 7,<br>3 - 8                                      | 11-330 964-15 | 3 - 9, 3 - 18,<br>3 - 21, 3 - 22   | 12-305 084-25 | 3 - 8   |
| 11-130 176-15 | 3 - 19, 3 - 22,<br>4 - 4, 4 - 5             | 11-186 934-25 | 3 - 7   | 11-330 966-05 | 16 - 1   | 12-305 114-05 | 3 - 18, 4 - 7                                     |
|               |   | 11-210 038-15 | 3 - 16  |               |  | 12-305 114-15 | 3 - 18  |
|               |   | 11-210 078-15 | 3 - 17  |               |  |               |   |

| No.           | Seite<br>Page<br>Pages<br>Página                 | No.           | Seite<br>Page<br>Pages<br>Página | No.           | Seite<br>Page<br>Pages<br>Página           | No.               | Seite<br>Page<br>Pages<br>Página |
|---------------|--|---------------|----------------------------------|---------------|--|-------------------|----------------------------------|
| 12-305 174-15 | 3 - 12, 3 - 21                                   | 12-710 904-12 | 3 - 13                           | 18-372 004-91 | 8 - 1                                      | 71-130 006-23     | 11 - 2                           |
| 12-305 314-15 | 3 - 11   | 13-030 998-05 | 3 - 22                           | 18-372 008-91 | 9 - 3, 16 - 2                              | 71-140 000-41     | 11 - 4                           |
| 12-315 080-15 | 3 - 17, 3 - 18,<br>9 - 2                         | 13-033 004-05 | 3 - 17                           | 18-373 011-91 | 16 - 2                                     | 71-370 001-32     | 3 - 4, 3 - 5,<br>11 - 2          |
| 12-315 090-25 | 3 - 7, 3 - 8                                     | 13-033 091-05 | 3 - 7                            | 18-378 002-91 | 16 - 2                                     | 71-370 001-33     | 10 - 2                           |
| 12-315 110-15 | 3 - 11   | 13-033 109-05 | 3 - 7, 3 - 8                     | 18-378 008-91 | 3 - 18, 4 - 3,<br>4 - 7, 7 - 1,<br>9 - 3   | 71-370 001-44     | 3 - 18                           |
| 12-315 140-15 | 4 - 4  | 13-033 208-05 | 3 - 13                           | 18-378 009-91 | 5 - 1                                      | 71-370 002-66     | 16 - 1                           |
| 12-335 191-15 | 16 - 2   | 13-052 046-55 | 3 - 16                           | 25-135 800-27 | 9 - 2, 9 - 3                               | 71-370 002-91     | 11 - 5                           |
| 12-341 090-25 | 3 - 13   | 13-060 902-05 | 4 - 4, 4 - 5                     | 25-161 801-49 | 3 - 15                                     | 71-370 002-92     | 11 - 5                           |
| 12-360 061-05 | 3 - 18, 4 - 7                                    | 13-060 904-05 | 4 - 5                            | 25-161 801-52 | 3 - 15, 4 - 4                              | 71-370 003-09     | 11 - 5                           |
| 12-360 173-05 | 3 - 13   | 13-064 262-05 | 3 - 13                           | 25-308 820-25 | 10 - 1                                     | 71-370 003-53     | 16 - 1                           |
| 12-360 184-15 | 3 - 11   | 13-064 388-05 | 3 - 11, 3 - 13                   | 25-308 820-30 | 6 - 1, 7 - 1,<br>9 - 3, 10 - 1,<br>10 - 2  | 71-590 006-94     | 11 - 4                           |
| 12-361 156-15 | 3 - 9  | 13-068 187-05 | 4 - 4                            | 25-308 820-40 | 8 - 1, 9 - 3,<br>10 - 1, 10 - 2,<br>16 - 2 | 71-590 007-12     | 11 - 3                           |
| 12-499 150-45 | 16 - 2   | 13-250 094-25 | 3 - 13                           | 25-308 820-60 | 8 - 1, 10 - 2,<br>16 - 2                   | 71-750 002-33     | 16 - 3                           |
| 12-499 170-45 | 6 - 1  | 14-016 151-91 | 3 - 18                           | 26-534 300-50 | 4 - 2                                      | 91-000 390-05     | 3 - 16                           |
| 12-499 190-45 | 8 - 1  | 14-018 644-91 | 3 - 9                            | 26-536 302-09 | 4 - 4                                      | 91-000 529-15     | 3 - 16                           |
| 12-505 190-45 | 3 - 7  | 14-218 090-01 | 3 - 3                            | 28-011 201-44 | 17 - 1                                     | 91-000 928-15     | 3 - 16                           |
| 12-510 171-15 | 3 - 12   | 14-218 100-91 | 3 - 13                           | 28-011 202-05 | 17 - 1                                     | 91-002 065-05     | 3 - 7, 3 - 8                     |
| 12-610 150-45 | 4 - 4  | 14-218 200-91 | 3 - 13                           | 28-011 202-43 | 17 - 1                                     | 91-002 262-25     | 3 - 7, 3 - 8                     |
| 12-610 170-45 | 3 - 2, 3 - 16,<br>4 - 2                          | 14-602 901-01 | 3 - 10                           | 28-011 202-47 | 17 - 1                                     | 91-010 183-05     | 3 - 7, 3 - 8                     |
| 12-610 200-45 | 3 - 16   | 14-650 251-05 | 3 - 21                           | 61-111 600-01 | 13 - 1                                     | 91-010 215-05     | 3 - 7, 3 - 8                     |
| 12-610 210-45 | 3 - 6, 10 - 2                                    | 15-032 001-45 | 5 - 1, 9 - 3,<br>16 - 2          | 61-111 600-35 | 13 - 1                                     | 91-011 374-05     | 3 - 13                           |
| 12-610 250-45 | 3 - 13   | 15-032 002-45 | 8 - 1                            | 61-111 633-60 | 13 - 1                                     | 91-011 391-05     | 4 - 1                            |
| 12-610 280-45 | 3 - 20   | 15-032 006-45 | 9 - 3                            | 71-120 005-98 | 11 - 5                                     | 91-018 293-05     | 3 - 16                           |
| 12-610 310-45 | 3 - 4, 3 - 5                                     | 15-120 707-05 | 3 - 16                           | 71-120 006-31 | 3 - 11                                     | 91-018 480-05     | 3 - 16                           |
| 12-610 330-45 | 3 - 11   | 15-120 902-05 | 3 - 16                           | 71-130 005-95 | 11 - 2                                     | 91-020 086-15     | 3 - 18, 3 - 19                   |
| 12-610 370-45 | 7 - 1  | 15-120 916-05 | 3 - 17                           | 71-130 005-96 | 11 - 2                                     | 91-027 651-75/699 | 13 - 1                           |
| 12-624 250-45 | 3 - 13   | 15-718 051-51 | 3 - 3, 4 - 5                     | 71-130 005-97 | 11 - 2                                     | 91-027 846-75/698 | 3 - 1                            |
| 12-624 310-45 | 3 - 13   | 16-040 010-11 | 3 - 18, 4 - 7                    | 71-130 005-98 | 11 - 2                                     | 91-027 918-91     | 10 - 2                           |
| 12-640 130-05 | 7 - 1  | 16-409 978-05 | 3 - 9                            | 71-130 005-99 | 11 - 2                                     | 91-029 741-15     | 4 - 4                            |
| 12-640 130-55 | 3 - 7, 3 - 8,<br>3 - 10, 3 - 18,<br>4 - 7, 6 - 1 | 16-414 103-05 | 15 - 1                           | 71-130 006-01 | 11 - 2                                     | 91-033 765-15     | 3 - 21                           |
| 12-640 150-55 | 3 - 8, 5 - 1,<br>6 - 1, 7 - 1                    | 18-278 005-91 | 9 - 3                            | 71-130 006-02 | 11 - 2                                     | 91-033 915-21     | 13 - 1                           |
| 12-710 270-12 | 3 - 3  | 18-279 010-05 | 9 - 3                            |               |  | 91-038 801-75/699 | 13 - 1                           |
|               |  | 18-372 003-91 | 8 - 1                            |               |  |                   |                                  |

Index (Teilenummern / Seitenzahlen)

Index (part numbers / page numbers)

Index (números de piezas, de pages)

Index (números de pieza / números de página)

PFAFF 1425

PFAFF 1426

PFAFF 3715

18

| No.               | Seite<br>Page<br>Pages<br>Página | No.           | Seite<br>Page<br>Pages<br>Página | No.               | Seite<br>Page<br>Pages<br>Página | No.               | Seite<br>Page<br>Pages<br>Página |
|-------------------|----------------------------------|---------------|----------------------------------|-------------------|----------------------------------|-------------------|----------------------------------|
| 91-056 192-25     | 3 - 7, 3 - 8,<br>3 - 10          | 91-118 685-05 | 3 - 10                           | 91-162 526-05     | 3 - 21                           | 91-166 491-01     | 4 - 2                            |
| 91-056 193-25     | 3 - 7, 3 - 8,<br>3 - 10          | 91-118 703-01 | 3 - 18,<br>3 - 19, 4 - 7         | 91-163 088-75/698 | 3 - 13                           | 91-166 507-91     | 3 - 3                            |
| 91-056 351-05     | 9 - 5                            | 91-118 704-05 | 3 - 18,<br>3 - 19, 4 - 7         | 91-164 902-01     | 3 - 6                            | 91-166 510-05     | 3 - 3                            |
| 91-056 578-91     | 3 - 10                           | 91-118 707-92 | 3 - 18,<br>3 - 19, 4 - 7         | 91-164 946-71/893 | 16 - 2                           | 91-166 511-92     | 3 - 3                            |
| 91-056 760-05     | 3 - 7, 3 - 8                     | 91-118 708-15 | 3 - 18                           | 91-165 887-91     | 5 - 1                            | 91-166 515-05     | 4 - 2                            |
| 91-069 062-05     | 3 - 2, 4 - 2                     | 91-118 709-15 | 3 - 19, 4 - 7                    | 91-166 067-15     | 4 - 5                            | 91-166 518-15     | 3 - 2                            |
| 91-089 467-05     | 6 - 1                            | 91-118 711-05 | 3 - 16, 3 - 17                   | 91-166 085-05     | 4 - 6                            | 91-166 522-91     | 4 - 3                            |
| 91-090 998-91     | 16 - 2                           | 91-118 712-91 | 3 - 18                           | 91-166 148-72/951 | 3 - 21                           | 91-166 524-91     | 3 - 3                            |
| 91-091 606-91     | 11 - 5                           | 91-118 713-01 | 3 - 18                           | 91-166 185-05     | 3 - 13                           | 91-166 529-05     | 3 - 3                            |
| 91-091 818-91     | 9 - 5                            | 91-118 724-12 | 3 - 18                           | 91-166 187-02     | 3 - 13                           | 91-166 531-05     | 4 - 2                            |
| 91-100 270-25     | 3 - 13                           | 91-118 787-15 | 3 - 17                           | 91-166 352-05     | 3 - 18, 4 - 7                    | 91-166 532-05     | 3 - 11, 4 - 2                    |
| 91-100 281-25     | 3 - 10                           | 91-118 880-91 | 3 - 14                           | 91-166 376-91     | 3 - 16                           | 91-166 533-05     | 3 - 11, 4 - 2                    |
| 91-100 355-05     | 3 - 5                            | 91-118 882-92 | 3 - 14                           | 91-166 378-05     | 3 - 16                           | 91-166 541-04/003 | 4 - 6                            |
| 91-100 396-15     | 3 - 16                           | 91-118 886-92 | 3 - 14                           | 91-166 381-05     | 3 - 17                           | 91-166 542-05     | 3 - 11                           |
| 91-105 447-25     | 3 - 7, 3 - 8                     | 91-118 888-05 | 3 - 14                           | 91-166 382-05     | 3 - 17                           | 91-166 543-05     | 3 - 11                           |
| 91-105 482-05     | 3 - 13                           | 91-118 893-92 | 3 - 20                           | 91-166 383-15     | 3 - 17                           | 91-166 545-05     | 7 - 1                            |
| 91-110 918-75/893 | 9 - 4, 9 - 5                     | 91-118 894-05 | 3 - 20                           | 91-166 384-05     | 3 - 17                           | 91-166 549-75/895 | 4 - 6                            |
| 91-113 023-92     | 3 - 8                            | 91-118 901-12 | 3 - 21                           | 91-166 388-05     | 3 - 16                           | 91-166 550-15     | 3 - 2                            |
| 91-113 027-15     | 3 - 8                            | 91-118 940-05 | 3 - 10                           | 91-166 391-15     | 3 - 16                           | 91-166 559-25     | 3 - 7                            |
| 91-113 445-15     | 6 - 1, 7 - 1                     | 91-119 015-15 | 3 - 4, 3 - 5                     | 91-166 393-01     | 3 - 2                            | 91-166 571-72/895 | 4 - 1                            |
| 91-118 044-91     | 3 - 14                           | 91-119 085-05 | 3 - 20                           | 91-166 394-71/951 | 3 - 21                           | 91-166 587-15     | 3 - 11                           |
| 91-118 045-91     | 3 - 14                           | 91-119 269-91 | 3 - 22                           | 91-166 452-21     | 3 - 10                           | 91-166 593-01     | 4 - 2                            |
| 91-118 067-25     | 3 - 14                           | 91-119 704-91 | 3 - 9                            | 91-166 464-71/895 | 4 - 4                            | 91-166 638-25     | 4 - 1                            |
| 91-118 099-91     | 3 - 10                           | 91-119 763-05 | 3 - 6                            | 91-166 466-72/895 | 4 - 4                            | 91-166 652-75/699 | 3 - 1                            |
| 91-118 137-91     | 3 - 22                           | 91-125 933-05 | 5 - 1                            | 91-166 470-75/895 | 4 - 1                            | 91-166 665-05     | 3 - 1                            |
| 91-118 154-90     | 3 - 18, 3 - 19,<br>4 - 7         | 91-129 917-91 | 17 - 1                           | 91-166 471-75/895 | 4 - 1                            | 91-166 670-15     | 11 - 4                           |
| 91-118 178-07     | 3 - 20                           | 91-129 919-91 | 17 - 1                           | 91-166 472-91     | 4 - 3                            | 91-166 708-90     | 11 - 4                           |
| 91-118 196-12     | 3 - 5                            | 91-129 920-91 | 17 - 1                           | 91-166 475-91     | 4 - 5                            | 91-166 717-15     | 3 - 1                            |
| 91-118 430-25     | 3 - 7                            | 91-140 199-02 | 3 - 16                           | 91-166 479-91     | 4 - 2                            | 91-166 807-15     | 5 - 1                            |
| 91-118 518-05     | 3 - 6                            | 91-140 239-05 | 3 - 17                           | 91-166 480-92     | 3 - 2, 4 - 2                     | 91-166 824-05     | 3 - 5                            |
| 91-118 570-92     | 3 - 9                            | 91-140 372-05 | 3 - 2                            | 91-166 485-01     | 3 - 2, 4 - 2                     | 91-166 827-05     | 3 - 16                           |
| 91-118 681-05     | 3 - 10                           | 91-140 676-05 | 3 - 17                           | 91-166 487-05     | 3 - 2, 4 - 2                     | 91-166 828-05     | 3 - 16                           |
| 91-118 683-05     | 3 - 10                           | 91-140 945-05 | 3 - 16                           | 91-166 488-01     | 4 - 2                            | 91-166 836-05     | 11 - 2                           |

| No.               | Seite<br>Page<br>Pages<br>Página | No.           | Seite<br>Page<br>Pages<br>Página | No.               | Seite<br>Page<br>Pages<br>Página | No.               | Seite<br>Page<br>Pages<br>Página |
|-------------------|----------------------------------|---------------|----------------------------------|-------------------|----------------------------------|-------------------|----------------------------------|
| 91-166 853-91     | 6 - 1                            | 91-173 988-05 | 4 - 7                            | 91-176 373-21     | 3 - 7, 3 - 8                     | 91-229 081-25     | 12 - 1                           |
| 91-166 879-91     | 10 - 2                           | 91-174 155-12 | 3 - 18, 3 - 19,<br>4 - 7         | 91-176 377-25     | 3 - 8                            | 91-229 082-25     | 12 - 1                           |
| 91-166 889-05     | 4 - 3                            | 91-174 303-15 | 3 - 4, 3 - 5                     | 91-176 378-05     | 3 - 7, 3 - 8                     | 91-229 123-25     | 12 - 1                           |
| 91-166 949-92     | 3 - 11                           | 91-174 344-92 | 3 - 9                            | 91-176 438-05     | 3 - 16                           | 91-229 124-25     | 12 - 1                           |
| 91-166 997-01     | 3 - 2                            | 91-174 783-05 | 3 - 10                           | 91-176 462-05     | 3 - 8                            | 91-229 125-25     | 12 - 1                           |
| 91-167 568-05     | 3 - 11                           | 91-174 879-05 | 3 - 10                           | 91-176 464-05     | 3 - 7, 3 - 8                     | 91-229 126-25     | 12 - 1                           |
| 91-168 055-91     | 3 - 9                            | 91-175 648-15 | 4 - 4                            | 91-176 482-91     | 3 - 6                            | 91-229 127-25     | 12 - 1                           |
| 91-168 194-71/698 | 3 - 7, 3 - 8                     | 91-175 649-15 | 4 - 4                            | 91-177 097-92     | 4 - 1                            | 91-229 128-25     | 12 - 1                           |
| 91-168 480-15     | 3 - 9                            | 91-175 908-05 | 3 - 16                           | 91-177 464-75/893 | 16 - 2                           | 91-229 129-25     | 12 - 1                           |
| 91-169 132-15     | 3 - 21                           | 91-176 063-15 | 6 - 1                            | 91-177 609-05     | 3 - 2                            | 91-262 195-92     | 3 - 9                            |
| 91-170 809-05     | 4 - 3                            | 91-176 076-91 | 3 - 18, 3 - 19,<br>4 - 7         | 91-177 610-05     | 3 - 2                            | 91-262 197-05     | 3 - 13                           |
| 91-171 042-05     | 3 - 10                           | 91-176 094-05 | 3 - 18, 3 - 19,<br>4 - 7         | 91-177 918-15     | 4 - 4                            | 91-262 202-15     | 3 - 13                           |
| 91-171 049-05     | 3 - 10                           | 91-176 103-91 | 3 - 19                           | 91-177 920-91     | 4 - 4                            | 91-262 203-05     | 3 - 13                           |
| 91-171 175-05     | 5 - 1                            | 91-176 177-91 | 3 - 9                            | 91-177 921-15     | 4 - 4                            | 91-266 104-75/698 | 3 - 1                            |
| 91-171 175-12     | 3 - 21                           | 91-176 178-05 | 3 - 2, 4 - 2                     | 91-186 659-05     | 3 - 17, 9 - 2                    | 91-266 105-75/698 | 3 - 1                            |
| 91-171 774-15     | 10 - 1                           | 91-176 180-05 | 4 - 2                            | 91-187 386-75/893 | 8 - 1                            | 91-266 106-75/699 | 3 - 1                            |
| 91-171 808-05     | 3 - 2                            | 91-176 188-05 | 4 - 2                            | 91-187 426-70/893 | 8 - 1                            | 91-266 107-75/698 | 3 - 1, 9 - 1                     |
| 91-171 875-12     | 3 - 3                            | 91-176 192-05 | 3 - 2, 4 - 2                     | 91-188 163-15     | 3 - 17, 9 - 2                    | 91-266 108-75/698 | 9 - 1                            |
| 91-173 072-05     | 3 - 22                           | 91-176 199-92 | 3 - 4, 3 - 5                     | 91-188 539-02     | 3 - 17                           | 91-266 114-15     | 3 - 1                            |
| 91-173 073-05     | 3 - 22                           | 91-176 204-05 | 3 - 4, 3 - 5                     | 91-202 231-71/951 | 9 - 3                            | 91-266 117-72/893 | 3 - 9                            |
| 91-173 082-72/951 | 3 - 22                           | 91-176 207-91 | 3 - 9                            | 91-229 068-75/895 | 12 - 1                           | 91-266 129-05     | 3 - 16                           |
| 91-173 139-15     | 6 - 1, 7 - 1                     | 91-176 267-05 | 3 - 2                            | 91-229 069-75/895 | 12 - 1                           | 91-266 132-05     | 3 - 16                           |
| 91-173 185-05     | 3 - 18                           | 91-176 302-05 | 3 - 6                            | 91-229 070-70/895 | 12 - 1                           | 91-266 136-05     | 3 - 16                           |
| 91-173 538-15     | 3 - 19                           | 91-176 309-05 | 3 - 5                            | 91-229 071-71/895 | 12 - 1                           | 91-266 172-05     | 3 - 2                            |
| 91-173 539-15     | 3 - 19                           | 91-176 315-05 | 3 - 6                            | 91-229 072-45     | 12 - 1                           | 91-266 173-05     | 3 - 2                            |
| 91-173 572-05     | 3 - 17                           | 91-176 321-05 | 3 - 8                            | 91-229 073-71/895 | 12 - 1                           | 91-266 236-15     | 3 - 19                           |
| 91-173 664-15     | 4 - 1                            | 91-176 323-05 | 3 - 8                            | 91-229 074-05     | 12 - 1                           | 91-266 241-05     | 9 - 2                            |
| 91-173 769-05     | 4 - 4                            | 91-176 324-25 | 3 - 7, 3 - 8                     | 91-229 075-45     | 12 - 1                           | 91-266 258-91     | 3 - 2                            |
| 91-173 770-05     | 4 - 4                            | 91-176 326-15 | 3 - 8                            | 91-229 076-75/698 | 12 - 1                           | 91-266 277-01     | 3 - 2                            |
| 91-173 906-24/001 | 3 - 14                           | 91-176 327-25 | 3 - 8                            | 91-229 077-72/895 | 12 - 1                           | 91-266 288-15     | 3 - 18, 3 - 19                   |
| 91-173 911-05     | 3 - 17                           | 91-176 329-05 | 3 - 7, 3 - 8                     | 91-229 078-25     | 12 - 1                           | 91-266 289-72/951 | 3 - 19                           |
| 91-173 915-92     | 3 - 16                           | 91-176 337-15 | 3 - 7                            | 91-229 079-25     | 12 - 1                           | 91-266 298-05     | 3 - 17, 9 - 2                    |
| 91-173 973-15     | 3 - 16                           | 91-176 360-05 | 3 - 12                           | 91-229 080-25     | 12 - 1                           | 91-266 299-91     | 3 - 17, 9 - 2                    |

Index (Teilenummern / Seitenzahlen)

Index (part numbers / page numbers)

Index (numéros de pièces, de pages)

Index (números de pieza / números de página)

PFAFF 1425

PFAFF 1426

PFAFF 3715

18

| No.               | Seite<br>Page<br>Pages<br>Página | No.               | Seite<br>Page<br>Pages<br>Página | No.               | Seite<br>Page<br>Pages<br>Página | No.               | Seite<br>Page<br>Pages<br>Página |
|-------------------|----------------------------------|-------------------|----------------------------------|-------------------|----------------------------------|-------------------|----------------------------------|
| 91-266 306-91     | 9 - 2                            | 91-266 463-71/698 | 3 - 8                            | 91-266 588-05     | 3 - 18                           | 91-266 700-92     | 5 - 1                            |
| 91-266 313-90     | 9 - 2                            | 91-266 465-71/698 | 3 - 7                            | 91-266 589-05     | 3 - 18                           | 91-266 701-91     | 3 - 22                           |
| 91-266 316-91     | 3 - 17                           | 91-266 479-91     | 3 - 21                           | 91-266 593-92     | 3 - 16                           | 91-266 706-25     | 3 - 14                           |
| 91-266 317-71/893 | 9 - 5                            | 91-266 481-05     | 3 - 22                           | 91-266 595-71/895 | 3 - 15                           | 91-266 707-75/698 | 3 - 13                           |
| 91-266 318-71/893 | 9 - 4                            | 91-266 482-05     | 3 - 21                           | 91-266 601-75/895 | 3 - 1                            | 91-266 710-71/698 | 3 - 11                           |
| 91-266 325-05     | 3 - 2, 4 - 2                     | 91-266 483-05     | 3 - 21                           | 91-266 602-75/895 | 3 - 1                            | 91-266 711-05     | 3 - 11                           |
| 91-266 326-05     | 3 - 2, 4 - 2                     | 91-266 484-05     | 3 - 21                           | 91-266 605-05     | 3 - 17                           | 91-266 712-05     | 3 - 11                           |
| 91-266 332-91     | 3 - 5                            | 91-266 486-15     | 3 - 11                           | 91-266 606-91     | 3 - 17                           | 91-266 713-05     | 3 - 11                           |
| 91-266 334-05     | 3 - 2                            | 91-266 490-90     | 6 - 1                            | 91-266 612-12     | 16 - 1                           | 91-266 714-75/893 | 3 - 11                           |
| 91-266 335-01     | 3 - 4, 3 - 5                     | 91-266 496-92     | 3 - 19                           | 91-266 613-11     | 16 - 1                           | 91-266 715-91     | 3 - 11                           |
| 91-266 347-15     | 3 - 1                            | 91-266 498-05     | 4 - 4                            | 91-266 617-71/893 | 3 - 1, 16 - 1                    | 91-266 716-05     | 3 - 11                           |
| 91-266 352-75/895 | 3 - 1                            | 91-266 504-91     | 3 - 16                           | 91-266 620-21     | 16 - 1                           | 91-266 717-05     | 3 - 11                           |
| 91-266 358-15     | 3 - 1                            | 91-266 505-91     | 3 - 16                           | 91-266 623-75/893 | 3 - 1, 9 - 1,<br>16 - 1          | 91-266 718-91     | 7 - 1                            |
| 91-266 359-05     | 3 - 17                           | 91-266 514-91     | 3 - 11                           | 91-266 652-00     | 3 - 17                           | 91-266 719-15     | 7 - 1                            |
| 91-266 381-05     | 3 - 18, 3 - 19,<br>4 - 7         | 91-266 520-92     | 3 - 22                           | 91-266 661-91     | 3 - 16                           | 91-266 720-05     | 3 - 11                           |
| 91-266 383-91     | 3 - 6                            | 91-266 521-71/895 | 3 - 13                           | 91-266 665-91     | 7 - 1                            | 91-266 728-15     | 3 - 18                           |
| 91-266 385-91     | 3 - 19                           | 91-266 522-75/895 | 3 - 13                           | 91-266 666-05     | 3 - 13                           | 91-266 729-04/004 | 3 - 11                           |
| 91-266 397-01     | 3 - 10                           | 91-266 523-75/698 | 3 - 13                           | 91-266 669-05     | 3 - 18                           | 91-266 730-05     | 3 - 13                           |
| 91-266 400-05     | 3 - 2                            | 91-266 524-12     | 3 - 13                           | 91-266 671-05     | 3 - 18                           | 91-266 738-05     | 3 - 7                            |
| 91-266 410-25     | 3 - 7, 3 - 8                     | 91-266 525-12     | 3 - 13                           | 91-266 672-05     | 3 - 18                           | 91-266 753-45     | 4 - 6                            |
| 91-266 411-25     | 3 - 7, 3 - 8                     | 91-266 528-05     | 3 - 13                           | 91-266 673-12     | 3 - 18                           | 91-266 757-05     | 3 - 7                            |
| 91-266 414-05     | 3 - 7, 3 - 8                     | 91-266 529-11     | 3 - 13                           | 91-266 675-92     | 5 - 1                            | 91-266 782-15     | 3 - 1                            |
| 91-266 416-92     | 3 - 12                           | 91-266 532-12     | 3 - 13                           | 91-266 676-05     | 5 - 1                            | 91-266 783-91     | 3 - 4                            |
| 91-266 417-92     | 3 - 12                           | 91-266 533-05     | 3 - 13                           | 91-266 678-72/895 | 4 - 1                            | 91-266 784-24/001 | 3 - 14                           |
| 91-266 424-91     | 3 - 18, 4 - 7                    | 91-266 537-71/698 | 3 - 13                           | 91-266 679-15     | 4 - 1                            | 91-266 796-15     | 3 - 11                           |
| 91-266 428-01     | 3 - 18, 4 - 7                    | 91-266 538-71/698 | 3 - 13                           | 91-266 679-91     | 5 - 1                            | 91-266 818-05     | 3 - 4                            |
| 91-266 432-91     | 3 - 12                           | 91-266 539-71/698 | 3 - 13                           | 91-266 681-91     | 3 - 16                           | 91-266 826-91     | 3 - 3                            |
| 91-266 436-91     | 3 - 7                            | 91-266 540-91     | 3 - 7                            | 91-266 683-91     | 3 - 16                           | 91-266 827-91     | 3 - 3                            |
| 91-266 438-25     | 3 - 7                            | 91-266 541-91     | 3 - 4                            | 91-266 684-05     | 3 - 16                           | 91-266 828-91     | 3 - 6                            |
| 91-266 440-71/698 | 3 - 7                            | 91-266 559-45     | 10 - 1                           | 91-266 685-91     | 3 - 16                           | 91-266 829-91     | 3 - 12                           |
| 91-266 445-91     | 3 - 8                            | 91-266 579-91     | 3 - 18                           | 91-266 688-90     | 9 - 2                            | 91-266 830-91     | 3 - 16                           |
| 91-266 447-71/698 | 3 - 8                            | 91-266 584-05     | 3 - 17, 9 - 2                    | 91-266 694-05     | 3 - 18                           | 91-266 831-91     | 3 - 17                           |
| 91-266 448-12     | 3 - 18                           | 91-266 585-01     | 3 - 17, 9 - 2                    | 91-266 697-05     | 5 - 1                            | 91-266 832-91     | 3 - 20                           |

| No.               | Seite<br>Page<br>Pages<br>Página | No.           | Seite<br>Page<br>Pages<br>Página | No.           | Seite<br>Page<br>Pages<br>Página | No. | Seite<br>Page<br>Pages<br>Página |
|-------------------|----------------------------------|---------------|----------------------------------|---------------|----------------------------------|-----|----------------------------------|
| 91-266 833-91     | 3 - 21                           | 99-115 425-91 | 3 - 18                           | 99-136 601-91 | 5 - 1                            |     |                                  |
| 91-266 834-91     | 3 - 22                           | 99-133 124-91 | 9 - 3                            | 99-136 757-05 | 10 - 2                           |     |                                  |
| 91-266 835-91     | 4 - 4                            | 99-133 125-91 | 9 - 3                            | 99-136 771-15 | 10 - 2                           |     |                                  |
| 91-266 836-91     | 4 - 4                            | 99-133 753-91 | 9 - 3                            | 99-136 778-91 | 3 - 10                           |     |                                  |
| 91-266 837-91     | 4 - 7                            | 99-134 206-05 | 16 - 2                           | 99-137 017-01 | 10 - 2                           |     |                                  |
| 91-266 838-91     | 3 - 6                            | 99-134 256-91 | 10 - 1, 10 - 2                   | 99-137 151-45 | 3 - 10                           |     |                                  |
| 91-266 839-91     | 3 - 6                            | 99-134 299-91 | 3 - 18, 4 - 6,<br>4 - 7, 9 - 3   | 99-137 223-91 | 10 - 1                           |     |                                  |
| 91-290 495-91     | 9 - 5                            | 99-134 369-91 | 16 - 2                           | 99-137 285-91 | 3 - 18                           |     |                                  |
| 91-290 577-91     | 9 - 4, 9 - 5,<br>16 - 2          | 99-134 370-91 | 10 - 2                           |               |                                  |     |                                  |
| 91-290 659-71/895 | 9 - 5                            | 99-134 421-91 | 3 - 18, 4 - 7                    |               |                                  |     |                                  |
| 91-291 133-91     | 3 - 7                            | 99-134 437-15 | 10 - 2                           |               |                                  |     |                                  |
| 91-291 442-91     | 11 - 5                           | 99-134 452-91 | 16 - 2                           |               |                                  |     |                                  |
| 91-291 560-71/699 | 11 - 2                           | 99-134 621-01 | 9 - 3, 16 - 2                    |               |                                  |     |                                  |
| 91-291 639-91     | 11 - 1                           | 99-134 850-91 | 16 - 2                           |               |                                  |     |                                  |
| 91-291 661-91     | 16 - 3                           | 99-135 001-95 | 10 - 1, 10 - 2                   |               |                                  |     |                                  |
| 91-291 664-91     | 16 - 1                           | 99-135 002-95 | 6 - 1, 9 - 2,<br>9 - 3, 10 - 1   |               |                                  |     |                                  |
| 91-291 685-91     | 16 - 1                           | 99-135 233-91 | 3 - 18, 4 - 6                    |               |                                  |     |                                  |
| 91-291 687-93/003 | 16 - 3                           | 99-135 353-91 | 4 - 4                            |               |                                  |     |                                  |
| 91-291 690-91     | 16 - 3                           | 99-135 490-91 | 6 - 1                            |               |                                  |     |                                  |
| 91-291 806-91     | 11 - 2                           | 99-135 496-95 | 3 - 15, 4 - 4                    |               |                                  |     |                                  |
| 91-291 945-91     | 9 - 1                            | 99-135 547-91 | 9 - 3                            |               |                                  |     |                                  |
| 91-700 173-15     | 3 - 14                           | 99-135 835-05 | 10 - 1                           |               |                                  |     |                                  |
| 91-700 249-15     | 3 - 17, 9 - 2                    | 99-135 890-91 | 4 - 6                            |               |                                  |     |                                  |
| 91-700 412-25     | 3 - 7, 3 - 11                    | 99-135 911-91 | 9 - 3                            |               |                                  |     |                                  |
| 91-700 510-15     | 3 - 9, 3 - 21                    | 99-136 031-91 | 4 - 3                            |               |                                  |     |                                  |
| 91-700 689-15     | 3 - 9, 3 - 14                    | 99-136 071-95 | 10 - 1                           |               |                                  |     |                                  |
| 91-701 522-25     | 3 - 7                            | 99-136 072-95 | 10 - 1                           |               |                                  |     |                                  |
| 95-215 000-04/847 | 5 - 1                            | 99-136 310-05 | 10 - 2                           |               |                                  |     |                                  |
| 95-617 317-15     | 9 - 3                            | 99-136 328-91 | 6 - 1                            |               |                                  |     |                                  |
| 95-665 735-91     | 17 - 1                           | 99-136 336-95 | 11 - 4                           |               |                                  |     |                                  |
| 95-780 087-75/895 | 9 - 5                            | 99-136 396-91 | 3 - 18,<br>3 - 19, 4 - 7         |               |                                  |     |                                  |
| 96-100 580-48     | 11 - 4                           | 99-136 486-91 | 7 - 1                            |               |                                  |     |                                  |
| 96-721 197-92     | 4 - 3                            | 99-136 546-91 | 8 - 1                            |               |                                  |     |                                  |

# PFAFF

G.M. PFAFF  
Aktiengesellschaft

Postfach 3020  
D-67653 Kaiserslautern

Königstr. 154  
D-67655 Kaiserslautern

Telefon: (0631) 200-0  
Telefax: (0631) 172 02  
Telex: 45753 PFAFF D

Gedruckt in der BRD  
Printed in Germany  
Imprimé en R.F.A.  
Impreso en la R.F.A.



# PFAFF

## 1425

## 1426

Unterklassen-Ausstattung

Subclass parts

Composition des sous-classes

Composición de las subclases

## 3715

-2/01

-2/02

## -2/04-900/81;/82 BN8♦

Für rechte Kantennäharbeiten.  
Standardform des Teilesatzes.  
Lineal auf hochklappbar.

For right-hand marginal stitching  
operations.  
Standard part set.  
Swing-up edge guide.

Piqûres longeant les bords.  
Jeu de pièces standard.  
Guide relevable.

Para el cosido de orillas o cantos.  
Juego de piezas estándar.  
Guía evadiza.

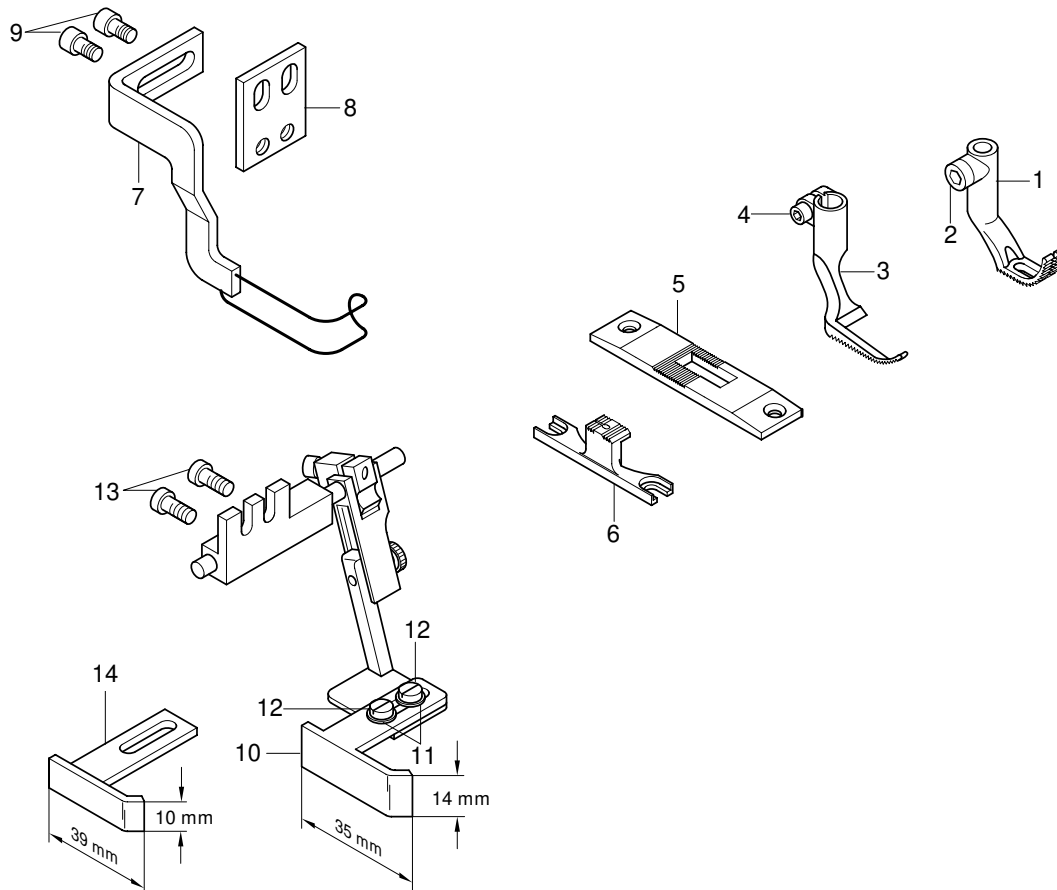

| Pos.-Nr.<br>Item No.<br>N° pos.<br>N° de pos. | Absteppbreite<br>Stitching margin<br>Relarge de couture<br>Margen de costura | Teile-Nr.<br>Part No.<br>N° de piezas<br>N° de pieza |
|---|--|--|
| 1 - 2   | 1,5<br>4,0   | 91-049 394-93/005<br>91-049 394-93/004               |
| 2   |  | 11-132 217-15  |
| 3 - 4   | 1,5<br>4,0   | 91-149 170-93/001<br>91-149 170-93/006               |
| 4   |  | 11-130 173-15  |
| 5   | 1,5<br>4,0   | 91-150 608-04/001<br>91-150 608-04/006               |
| 6   | 1,5<br>4,0   | 91-059 936-04/001<br>91-059 936-04/005               |
| 7 - 9   |  | 91-155 426-91  |

| Pos.-Nr.<br>Item No.<br>N° pos.<br>N° de pos. | Absteppbreite<br>Stitching margin<br>Relarge de couture<br>Margen de costura | Teile-Nr.<br>Part No.<br>N° de piezas<br>N° de pieza |
|---|--|--|
| 7   |  | 91-155 427-91  |
| 8   |  | 91-057 698-15  |
| 9   |  | 11-130 167-15  |
| 10 - 13                                       |  | 09-009 824-22  |
| 10  |  | 99-117 869-23  |
| 11  |  | 91-100 120-25  |
| 12  |  | 12-305 114-25  |
| 13  |  | 11-132 223-15  |
| 14  |  | 99-117 868-23  |

-2/04-900/81;/82 CN8<sup>♦</sup>

Für rechte Kantennäharbeiten.  
Standardform des Teilesatzes.  
Lineal auf hochklappbar.

For right-hand marginal stitching  
operations.  
Standard part set.  
Swing-up edge guide.

Piqûres longeant les bords.  
Jeu de pièces standard.  
Guide relavable.

Para el cosido de orillas o cantos.  
Juego de piezas estándar.  
Guía evadiza.

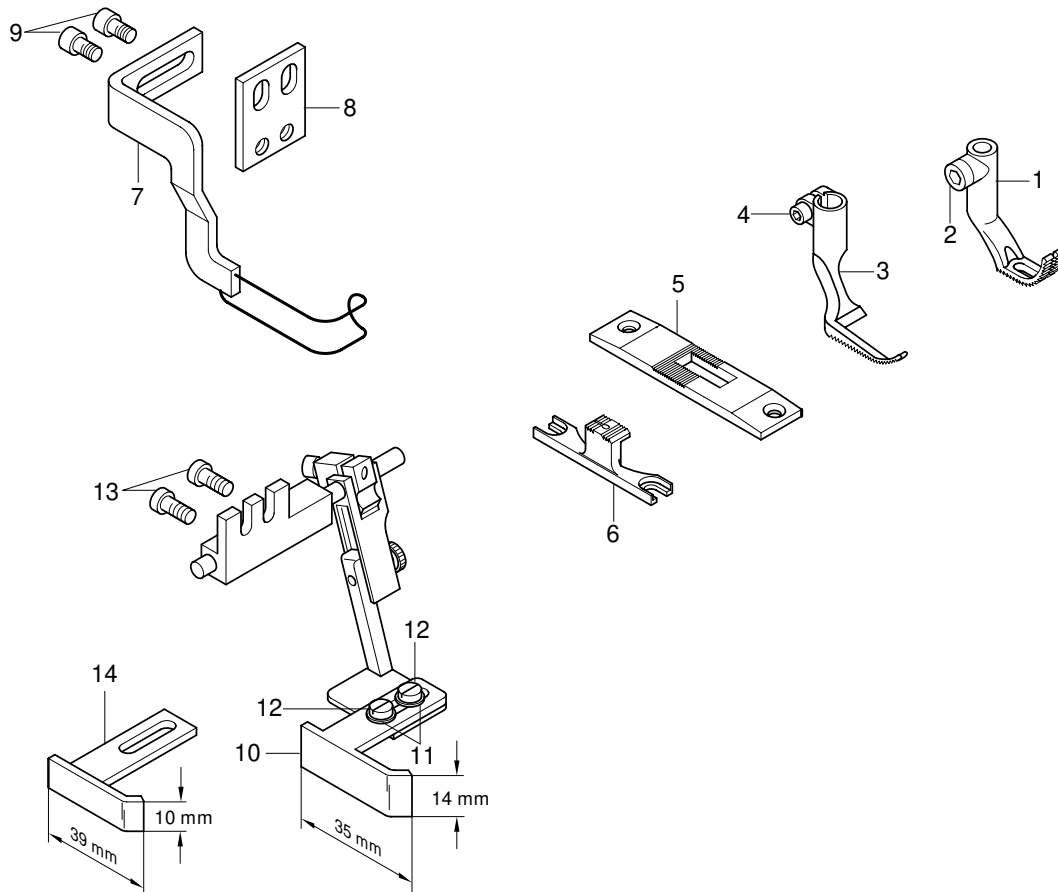

| Pos.-Nr.<br>Item No.<br>N° pos.<br>N° de pos. | Absteppbreite<br>Stitching margin<br>Relarge de couture<br>Margen de costura | Teile-Nr.<br>Part No.<br>N° de piezas<br>N° de piezas | Pos.-Nr.<br>Item No.<br>N° pos.<br>N° de pos. | Absteppbreite<br>Stitching margin<br>Relarge de couture<br>Margen de costura | Teile-Nr.<br>Part No.<br>N° de piezas<br>N° de piezas |
|---|--|---|---|--|---|
| 1 - 13  | 2,5  | 91-201 788-93/001                                     | 7 - 9   |  | 91-155 426-91   |
| 1 - 2   | 2,5<br>4,0   | 91-049 394-93/012<br>91-049 394-93/003                | 7   |  | 91-155 427-91   |
| 2   |  | 11-132 217-15   | 8   |  | 91-057 698-15   |
| 3 - 4   | 2,5<br>4,0   | 91-149 170-93/011<br>91-149 170-93/014                | 9   |  | 11-130 167-15   |
| 4   |  | 11-130 173-15   | 10 - 13                                       |  | 09-009 824-22   |
| 5   | 2,5<br>4,0   | 91-150 608-04/009<br>91-150 608-04/012                | 10  |  | 99-117 869-23   |
| 6   | 2,5<br>4,0   | 91-059 936-04/009<br>91-059 936-04/012                | 11  |  | 91-100 120-25   |
|   |  |   | 12  |  | 12-305 114-25   |
|   |  |   | 13  |  | 11-132 223-15   |
|   |  |   | 14  |  | 99-117 868-23   |

## -3/04-900/81;/82 BN8♦

Für linke Kantennäharbeiten.  
Standardform des Teilesatzes.  
Fußpaar gezahnt.

For reworking left-hand edges.  
Standard part set.  
Toothed feet pair.

Pour les coutures au bord gauche.  
Jeu de pièces standard.  
Semelles des pieds crantées.

Para costuras marginales a la izquierda.  
Juego de piezas estándar.  
Par de pies prensatelas dentados.

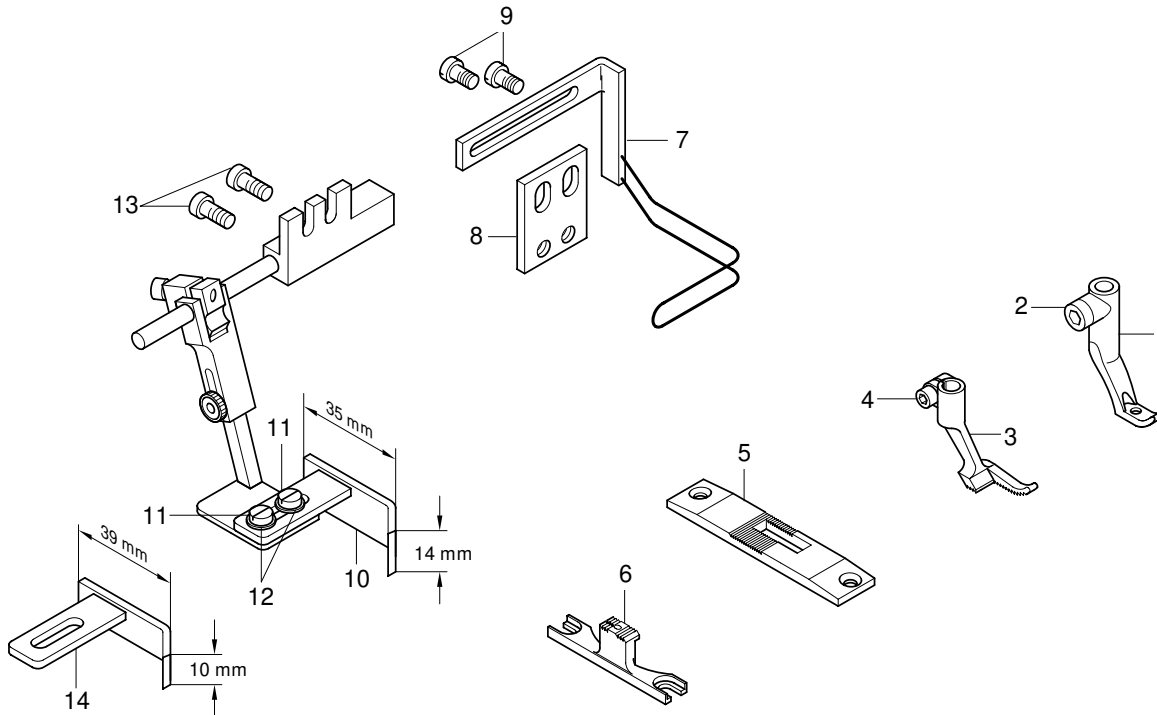

| Pos.-Nr.<br>Item No.<br>N° pos.<br>N° de pos. | Absteppbreite<br>Stitching margin<br>Relarge de couture<br>Margen de costura | Teile-Nr.<br>Part No.<br>N° de piezas<br>N° de pieza   | Pos.-Nr.<br>Item No.<br>N° pos.<br>N° de pos. | Absteppbreite<br>Stitching margin<br>Relarge de couture<br>Margen de costura | Teile-Nr.<br>Part No.<br>N° de piezas<br>N° de pieza   |
|---|--|--|---|--|--|
| 1 - 2   | 1,5<br>2,0<br>2,5<br>3,0<br>3,5<br>4,0                                       | 91-049 408-93/002<br>91-049 408-93/003<br>91-049 408-93/005<br>91-049 408-93/006<br>91-049 408-93/006<br>91-049 408-93/008 | 6   | 1,5<br>2,0<br>2,5<br>3,0<br>3,5<br>4,0                                       | 91-059 941-04/001<br>91-059 941-04/002<br>91-059 941-04/003<br>91-059 941-04/004<br>91-059 941-04/005<br>91-059 941-04/006 |
| 2   |  | 11-132 217-15  | 7 - 9   |  | 91-154 625-91  |
| 3 - 4   | 1,5<br>2,0<br>2,5<br>3,0<br>3,5<br>4,0                                       | 91-149 172-93/001<br>91-149 172-93/002<br>91-149 172-93/003<br>91-149 172-93/004<br>91-149 172-93/005<br>91-149 172-93/006 | 7   |  | 91-057 714-91  |
| 4   |  | 11-130 173-15  | 8   |  | 91-057 698-15  |
| 5   | 1,5<br>2,0<br>2,5<br>3,0<br>3,5<br>4,0                                       | 91-150 618-04/001<br>91-150 618-04/002<br>91-150 618-04/003<br>91-150 618-04/004<br>91-150 618-04/005<br>91-150 618-04/006 | 9   |  | 11-108 168-15  |
|   |  |  | 10 - 13                                       |  | 09-009 844-35  |
|   |  |  | 10  |  | 99-117 869-23  |
|   |  |  | 11  |  | 91-100 120-25  |
|   |  |  | 12  |  | 12-305 114-25  |
|   |  |  | 13  |  | 11-132 223-15  |
|   |  |  | 14  |  | 99-117 868-23  |

-3/04-900/81;/82 CN8<sup>♦</sup>

Für linke Kantennäharbeiten.  
 Standardform des Teilesatzes.  
 Fußpaar gezahnt.

For reworking left-hand edges.  
 Standard part set.  
 Toothed feet pair.

Pour les coutures au bord gauche.  
 Jeu de pièces standard.  
 Semelles des pieds crantées.

Para costuras marginales a la izquierda.  
 Juego de piezas estándar.  
 Par de pies prensatelas dentados.

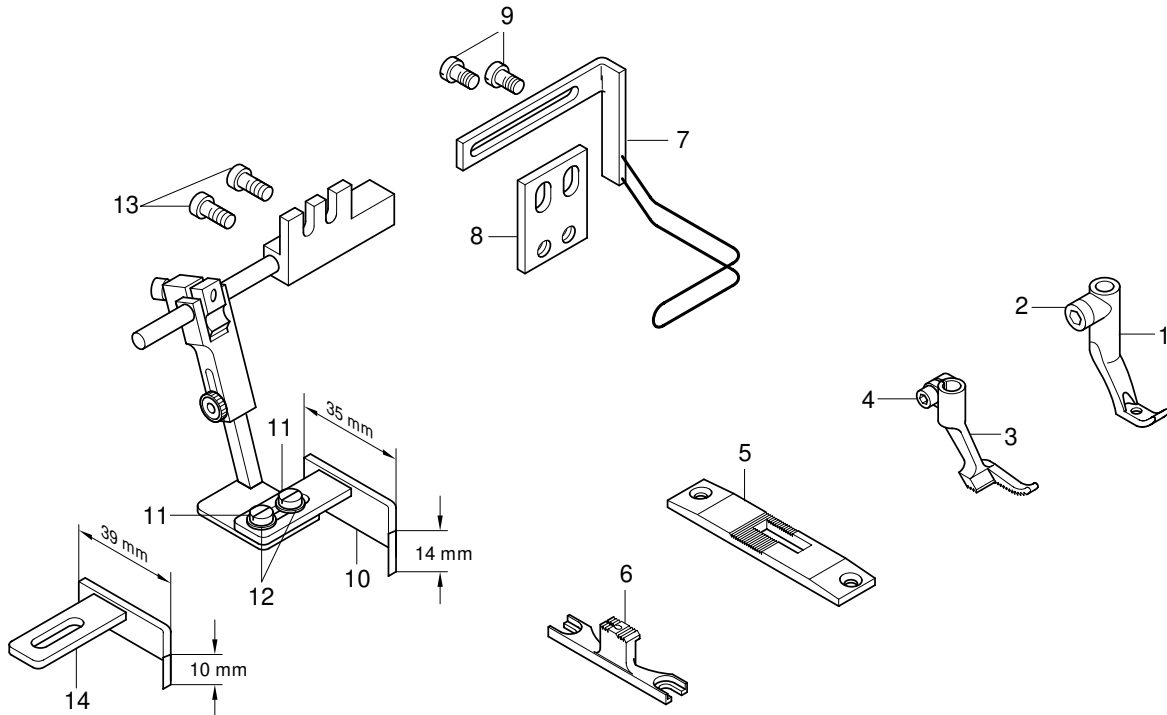

| Pos.-Nr.<br>Item No.<br>N° pos.<br>N° de pos. | Absteppbreite<br>Stitching margin<br>Relarge de couture<br>Margen de costura | Teile-Nr.<br>Part No.<br>N° de piezas<br>N° de pieza  |
|---|--|---|
| 1 - 13  | 3,0  | 91-201 792-93/001   |
| 1 - 2   | 2,5<br>3,0<br>3,5<br>4,0<br>5,0  | 91-049 408-93/007<br>91-049 408-93/007<br>91-049 408-93/001<br>91-049 408-93/001<br>91-049 408-93/011 |
| 2   |  | 11-132 217-15   |
| 3 - 4   | 2,5<br>3,0<br>3,5<br>4,0<br>5,0  | 91-149 172-93/009<br>91-149 172-93/010<br>91-149 172-93/011<br>91-149 172-93/012<br>91-149 172-93/014 |
| 4   |  | 11-130 173-15   |
| 5   | 2,5<br>3,0<br>3,5<br>4,0<br>5,0  | 91-150 618-04/015<br>91-150 618-04/010<br>91-150 618-04/011<br>91-150 618-04/012<br>91-150 618-04/012 |

| Pos.-Nr.<br>Item No.<br>N° pos.<br>N° de pos. | Absteppbreite<br>Stitching margin<br>Relarge de couture<br>Margen de costura | Teile-Nr.<br>Part No.<br>N° de piezas<br>N° de pieza  |
|---|--|---|
| 6   | 2,5<br>3,0<br>3,5<br>4,0<br>5,0  | 91-059 941-04/009<br>91-059 941-04/010<br>91-059 941-04/011<br>91-059 941-04/012<br>91-059 941-04/012 |
| 7 - 9   |  | 91-154 625-91   |
| 7   |  | 91-057 714-91   |
| 8   |  | 91-057 698-15   |
| 9   |  | 11-108 168-15   |
| 10 - 13                                       |  | 09-009 844-35   |
| 10  |  | 99-117 869-23   |
| 11  |  | 91-100 120-25   |
| 12  |  | 12-305 114-25   |
| 13  |  | 11-132 223-15   |
| 14  |  | 99-117 868-23   |

-6/07-900/81;/82 BN8<sup>◆</sup>

Für Nähte mit Übergängen  
 (Kletterteilesatz).

For seams involving cross seams  
 (climbing parts set).

Couture de matières à suré-  
 paiseurs (pied grim pant).

Para costuras con desniveles  
 (juego de piezas trepador).

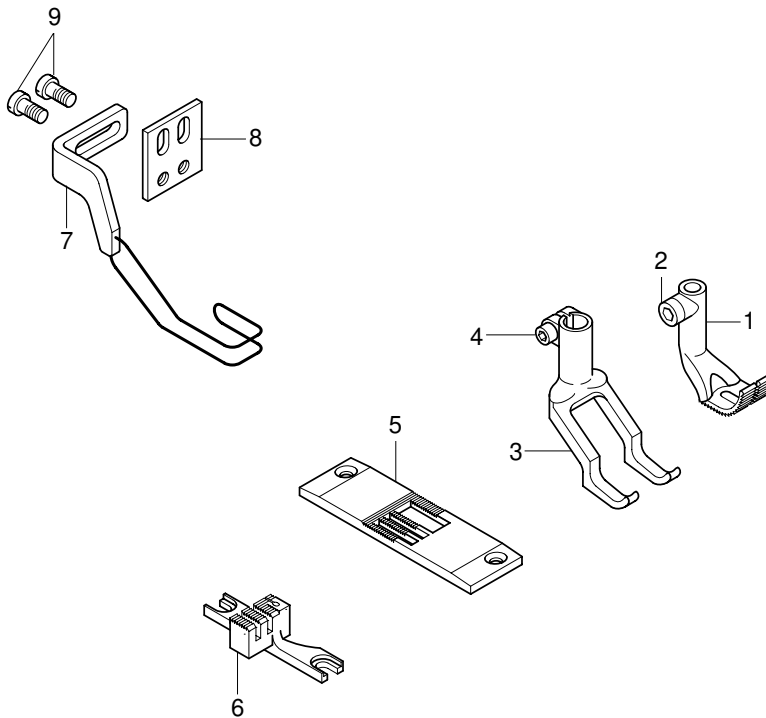

| Pos.-Nr.<br>Item No.<br>N° pos.<br>N° de pos. | Teile-Nr.<br>Part No.<br>N° de piezas<br>N° de pieza |
|---|--|
| 1 - 2   | 91-049 394-93/004                                    |
| 2   | 11-132 217-15  |
| 3 - 4   | 91-049 772-93/022                                    |
| 4   | 11-130 173-15  |
| 5   | 91-150 600-04/001                                    |

| Pos.-Nr.<br>Item No.<br>N° pos.<br>N° de pos. | Teile-Nr.<br>Part No.<br>N° de piezas<br>N° de pieza |
|---|--|
| 6   | 91-059 933-04/003                                    |
| 7 - 9   | 91-154 696-91  |
| 7   | 91-154 697-91  |
| 8   | 91-057 698-15  |
| 9   | 11-108 171-15  |

-6/07-900/81;/82 CN8<sup>♦</sup>

Für Nähte mit Übergängen  
 (Kletterteilesatz).

For seams involving cross seams  
 (climbing parts set).

Couture de matières à suré-  
 paiseurs (pied grim pant).

Para costuras con desniveles  
 (juego de piezas trepador).

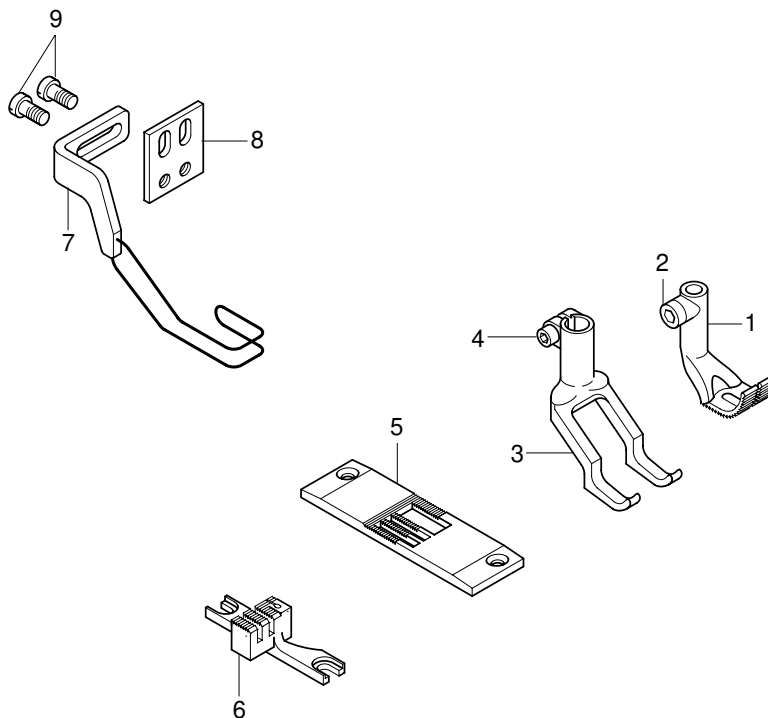

| Pos.-Nr.<br>Item No.<br>N° pos.<br>N° de pos. | Teile-Nr.<br>Part No.<br>N° de pièces<br>N° de pieza | Pos.-Nr.<br>Item No.<br>N° pos.<br>N° de pos. | Teile-Nr.<br>Part No.<br>N° de pièces<br>N° de pieza |
|---|--|---|--|
| 1 - 9   | 91-201 795-93/001                                    | 6   | 91-059 933-04/001                                    |
| 1 - 2   | 91-049 394-93/003                                    | 7 - 9   | 91-154 696-91  |
| 2   | 11-132 217-15  | 7   | 91-154 697-91  |
| 3 - 4   | 91-049 772-93/032                                    | 8   | 91-057 698-15  |
| 4   | 11-130 173-15  | 9   | 11-108 171-15  |
| 5   | 91-150 600-04/001                                    |   |  |

## -6/13-900/81;/82 BN8♦

Für allgemeine Näharbeiten;  
 jedoch mit Dacron-Fußpaar.

For ordinary sewing operations  
 but with Dacron feet pair.

Travaux d'utilité courante,  
 mais avec paire de pieds  
 avec semelle en Dacron.

Para trabajos de costura en general,  
 preo con planta de Dacron.

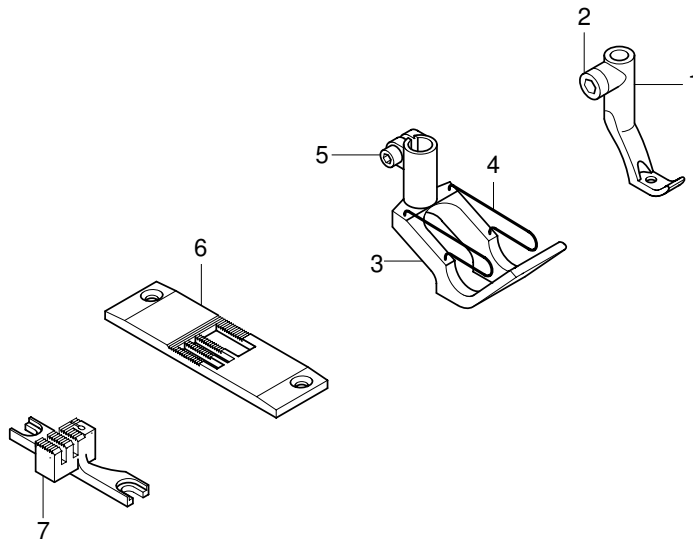

| Pos.-Nr.<br>Item No.<br>N° pos.<br>N° de pos. | Teile-Nr.<br>Part No.<br>N° de pieces<br>N° de pieza |
|---|--|
| 1 - 2   | 91-049 408-93/008                                    |
| 2   | 11-132 217-15  |
| 3 - 5   | 91-149 159-91  |
| 4   | 91-149 161-05 [3/1]                                  |

| Pos.-Nr.<br>Item No.<br>N° pos.<br>N° de pos. | Teile-Nr.<br>Part No.<br>N° de pieces<br>N° de pieza |
|---|--|
| 5   | 11-130 173-15  |
| 6   | 91-150 600-04/001                                    |
| 7   | 91-059 933-04/003                                    |



-6/13-900/81;/82 CN8♦

Für allgemeine Näharbeiten;  
 jedoch mit Dacron-Fußpaar.

For ordinary sewing operations  
 but with Dacron feet pair.

Travaux d'utilité courante,  
 mais avec paire de pieds  
 avec semelle en Dacron.

Para trabajos de costura en general,  
 preo con planta de Dacron.

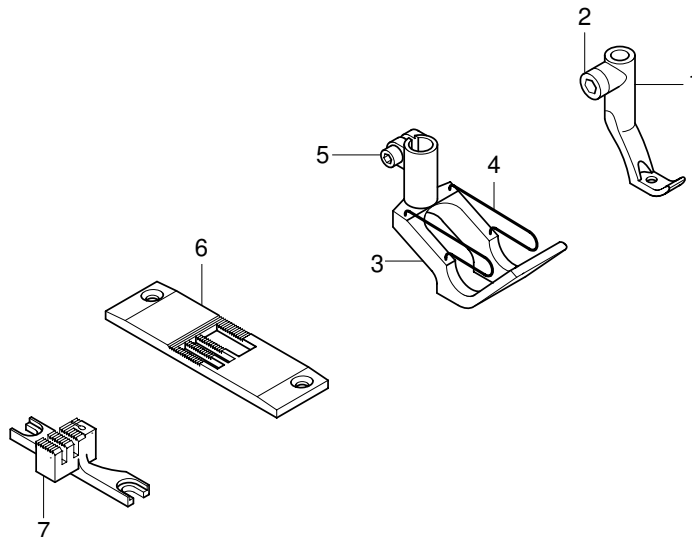

| Pos.-Nr.<br>Item No.<br>N° pos.<br>N° de pos. | Teile-Nr.<br>Part No.<br>N° de pieces<br>N° de pieza |
|---|--|
| 1 - 7   | 91-201 796-93/001                                    |
| 1 - 2   | 91-049 408-93/001                                    |
| 2   | 11-132 217-15  |
| 3 - 5   | 91-149 159-91  |

| Pos.-Nr.<br>Item No.<br>N° pos.<br>N° de pos. | Teile-Nr.<br>Part No.<br>N° de pieces<br>N° de pieza                            |
|---|---|
| 4   | 91-149 161-05 <span style="border: 1px solid black; padding: 0 2px;">3/1</span> |
| 5   | 11-130 173-15   |
| 6   | 91-150 600-04/001   |
| 7   | 91-059 933-04/001   |

## -6/01-900/81;/82 BN8♦

Für allgemeine Näharbeiten.  
Standardform des Teilesatzes.

For ordinary sewing operations.  
Standard part set.

Travaux d'utilité courante.  
Jeu de pièces standard.

Para trabajos de costura en general.  
Juego de piezas estándar.

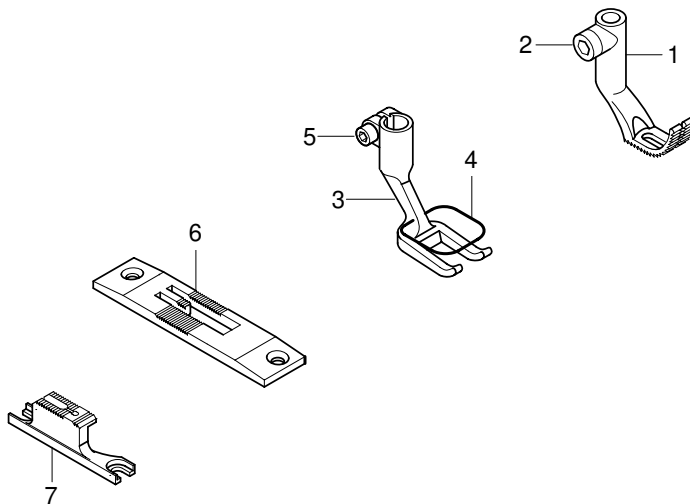

| Pos.-Nr.<br>Item No.<br>N° pos.<br>N° de pos. | Teile-Nr.<br>Part No.<br>N° de pieces<br>N° de pieza |
|---|--|
| 1 - 2   | 91-049 394-93/004                                    |
| 2   | 11-132 217-15  |
| 3 - 5   | 91-149 162-93/003                                    |
| 4   | 91-149 163-05 [3/1]                                  |

| Pos.-Nr.<br>Item No.<br>N° pos.<br>N° de pos. | Teile-Nr.<br>Part No.<br>N° de pieces<br>N° de pieza |
|---|--|
| 5   | 11-130 173-15  |
| 6   | 91-150 602-05  |
| 7   | 91-059 935-04/001                                    |

-6/14-900/81;/82 CN8<sup>◆</sup>

Für allgemeine Näharbeiten.  
 Standardform des Teilesatzes.

For ordinary sewing operations.  
 Standard part set.

Travaux d'utilité courante.  
 Jeu de pièces standard.

Para trabajos de costura en general.  
 Juego de piezas estándar.

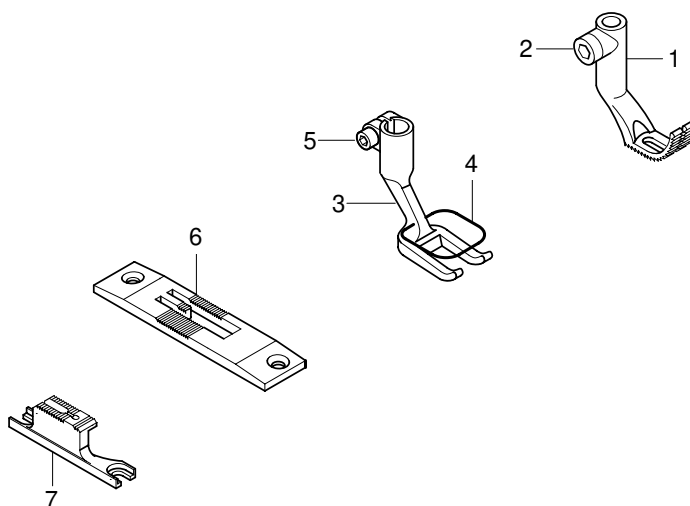

| Pos.-Nr.<br>Item No.<br>N° pos.<br>N° de pos. | Teile-Nr.<br>Part No.<br>N° de pièces<br>N° de pieza |
|---|--|
| 1 - 7   | 91-202 377-93/001                                    |
| 1 - 2   | 91-049 394-93/003                                    |
| 2   | 11-132 217-15  |
| 3 - 5   | 91-149 162-93/001                                    |

| Pos.-Nr.<br>Item No.<br>N° pos.<br>N° de pos. | Teile-Nr.<br>Part No.<br>N° de pièces<br>N° de pieza                            |
|---|---|
| 4   | 91-149 163-05 <span style="border: 1px solid black; padding: 0 2px;">3/1</span> |
| 5   | 11-130 173-15   |
| 6   | 91-150 602-05   |
| 7   | 91-059 935-04/001   |

## -6/17-900/81;/82 BN8♦

Für allgemeine Näharbeiten;  
 jedoch mit Schiffchenfuß.

For ordinary sewing operations  
 but with boat-shaped foot.

Travaux d'utilité courante,  
 mais avec pied-bâteau.

Para trabajos de costura en general,  
 preo con pie tipo barco.

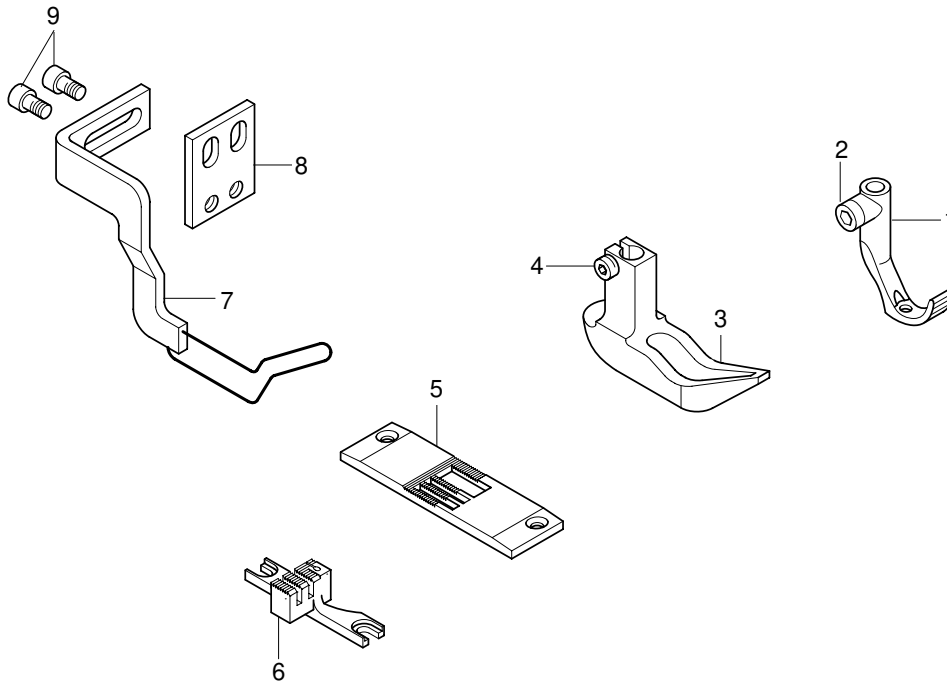

| Pos.-Nr.<br>Item No.<br>N° pos.<br>N° de pos. | Teile-Nr.<br>Part No.<br>N° de pièces<br>N° de pieza |
|---|--|
| 1 - 9   | 91-201 797-93/001                                    |
| 1 - 2   | 91-149 110-93/003                                    |
| 2   | 11-132 217-15  |
| 3 - 4   | 91-049 961-92  |
| 4   | 11-330 277-15  |
| 5   | 91-150 600-04/001                                    |

| Pos.-Nr.<br>Item No.<br>N° pos.<br>N° de pos. | Teile-Nr.<br>Part No.<br>N° de pièces<br>N° de pieza |
|---|--|
| 6   | 91-059 933-04/003                                    |
| 7 - 9   | 91-154 484-91  |
| 7   | 91-154 485-91  |
| 8   | 91-057 698-15  |
| 9   | 11-130 167-15  |

-6/17-900/81;/82 CN8<sup>◆</sup>

Für allgemeine Näharbeiten;  
 jedoch mit Schiffchenfuß.

For ordinary sewing operations  
 but with boat-shaped foot.

Travaux d'utilité courante,  
 mais avec pied-bâteau.

Para trabajos de costura en general,  
 preo con pie tipo barco.

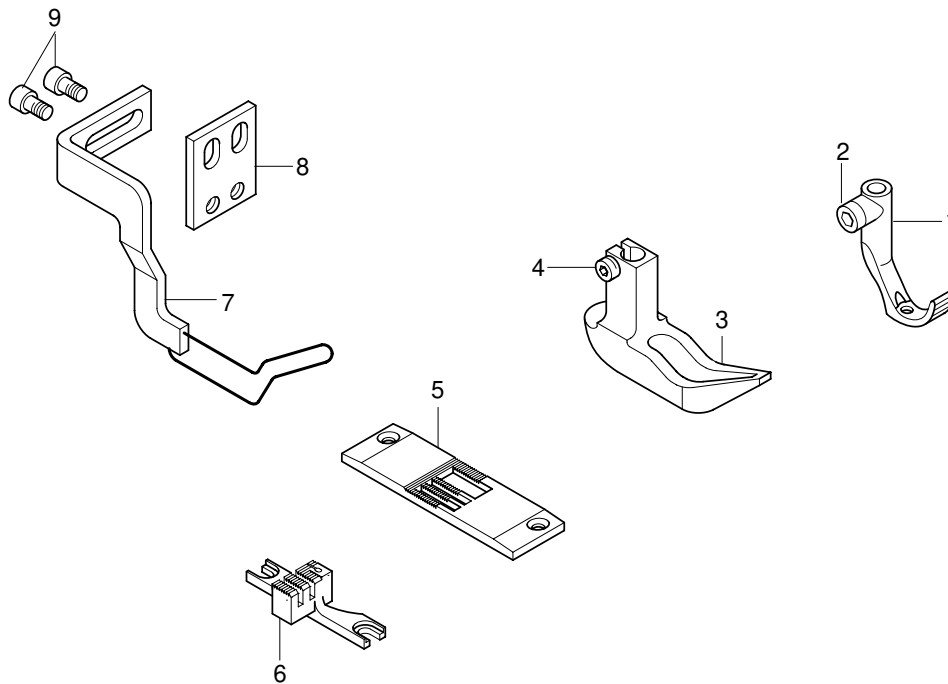

| Pos.-Nr.<br>Item No.<br>N° pos.<br>N° de pos. | Teile-Nr.<br>Part No.<br>N° de pièces<br>N° de pieza |
|---|--|
| 1 - 9   | 91-201 797-93/002                                    |
| 1 - 2   | 91-149 110-93/002                                    |
| 2   | 11-132 217-15  |
| 3 - 4   | 91-049 961-92  |
| 4   | 11-330 277-15  |
| 5   | 91-150 600-04/001                                    |

| Pos.-Nr.<br>Item No.<br>N° pos.<br>N° de pos. | Teile-Nr.<br>Part No.<br>N° de pièces<br>N° de pieza |
|---|--|
| 6   | 91-059 933-04/001                                    |
| 7 - 9   | 91-154 484-91  |
| 7   | 91-154 485-91  |
| 8   | 91-057 698-15  |
| 9   | 11-130 167-15  |

-17/01-900/81;/82 BN8<sup>♦</sup>

Arbeitsgang  
 Operation  
 Opération  
 Operación

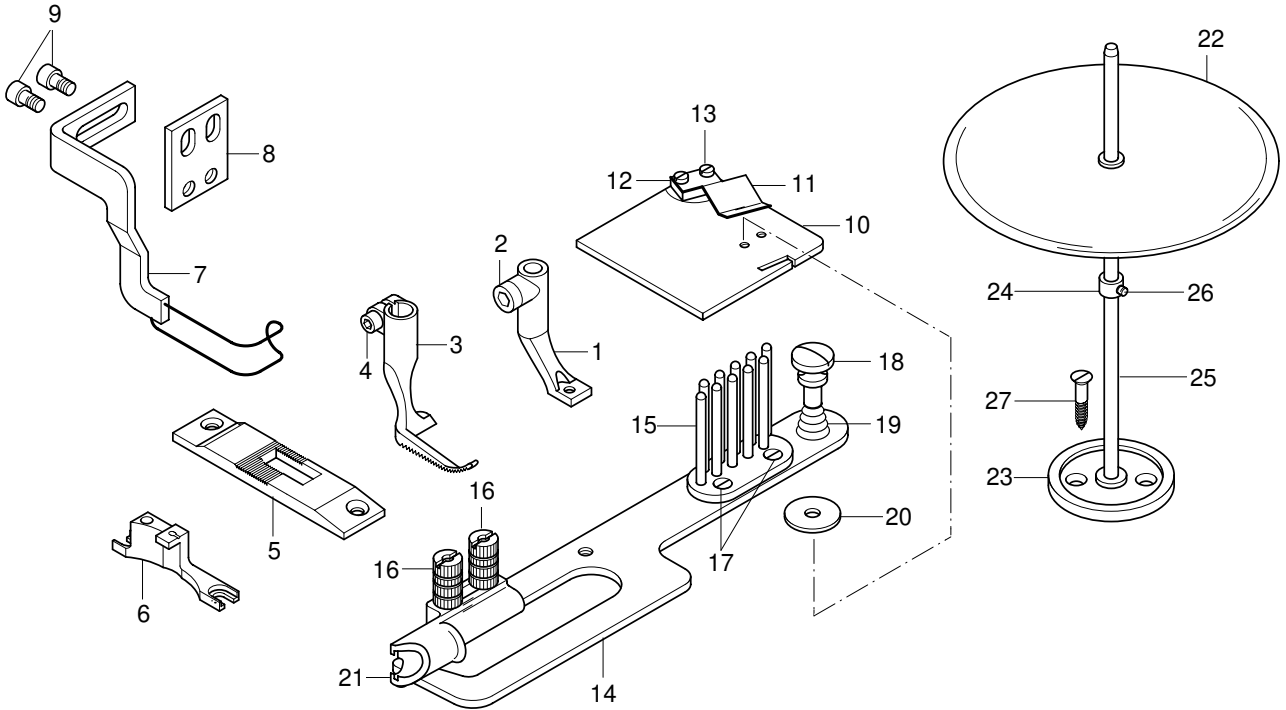
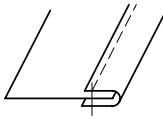

| Pos.-Nr.<br>Item No.<br>N° pos.<br>N° de pos. | Teil-Nr.<br>Part No.<br>N° de pièces<br>N° de piezas |
|---|--|
| 1 - 2   | 91-049 491-93/007                                    |
| 2   | 11-132 217-15  |
| 3 - 4   | 91-049 862-93/001                                    |
| 4   | 11-130 173-15  |
| 5   | 91-150 601-05  |
| 6   | 91-059 934-04/001                                    |
| 7 - 9   | 91-155 426-91  |
| 7   | 91-155 427-91  |
| 8   | 91-057 698-15  |
| 9   | 11-130 167-15  |
| 10 - 13                                       | 91-266 407-91  |
| 10  | 91-266 406-25  |
| 11  | 91-170 364-15  |
| 12  | 91-170 363-15  |
| 13  | 11-108 174-15  |
| 14 - 20                                       | 91-156 269-90  |

| Pos.-Nr.<br>Item No.<br>N° pos.<br>N° de pos. | Teil-Nr.<br>Part No.<br>N° de pièces<br>N° de piezas |
|---|--|
| 14  | 91-053 752-23/003                                    |
| 15  | 91-044 251-21  |
| 16  | 91-001 592-25  |
| 17  | 91-000 380-25  |
| 18  | 91-000 824-25  |
| 19  | 91-040 624-25  |
| 20  | 91-028 036-25  |
| 21  | 91-040 533-23/012                                    |
| 22 - 27                                       | 91-043 943-70/895                                    |
| 22  | 91-043 124-71/895                                    |
| 23  | 91-043 945-75/895                                    |
| 24  | 91-043 947-92  |
| 25  | 91-043 946-25  |
| 26  | 91-000 388-15  |
| 27  | 11-470 355-25  |

-17/01-900/81;/82 CN8♦

Arbeitsgang  
 Operation  
 Opération  
 Operación

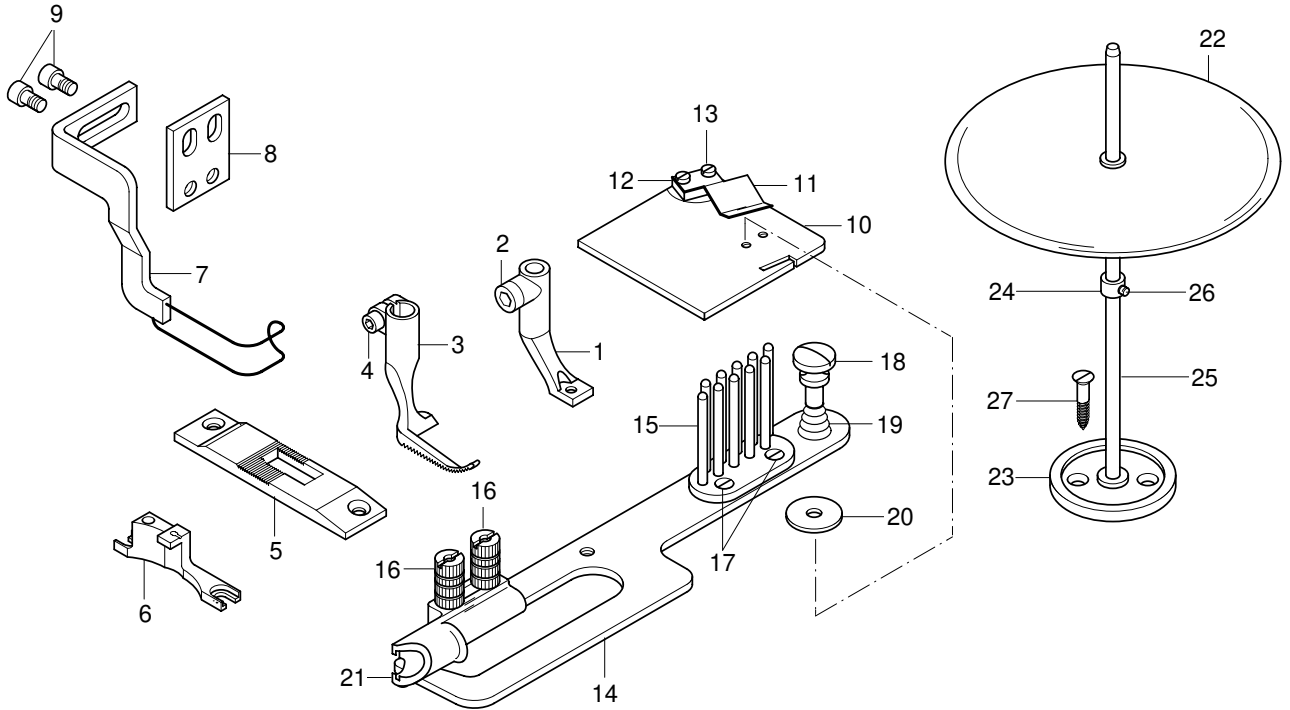
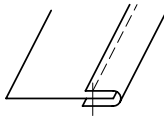

| Pos.-Nr.<br>Item No.<br>N° pos.<br>N° de pos. | Teile-Nr.<br>Part No.<br>N° de pièces<br>N° de pieza | Pos.-Nr.<br>Item No.<br>N° pos.<br>N° de pos. | Teile-Nr.<br>Part No.<br>N° de pièces<br>N° de pieza |
|---|--|---|--|
| 1 - 2   | 91-049 491-93/001                                    | 14  | 91-053 752-23/003                                    |
| 2   | 11-132 217-15  | 15  | 91-044 251-21  |
| 3 - 4   | 91-049 862-93/002                                    | 16  | 91-001 592-25  |
| 4   | 11-130 173-15  | 17  | 91-000 380-25  |
| 5   | 91-150 601-05  | 18  | 91-000 824-25  |
| 6   | 91-059 934-04/002                                    | 19  | 91-040 624-25  |
| 7 - 9   | 91-155 426-91  | 20  | 91-028 036-25  |
| 7   | 91-155 427-91  | 21  | 91-040 533-23/012                                    |
| 8   | 91-057 698-15  | 22 - 27                                       | 91-043 943-70/895                                    |
| 9   | 11-130 167-15  | 22  | 91-043 124-71/895                                    |
| 10 - 13                                       | 91-266 407-91  | 23  | 91-043 945-75/895                                    |
| 10  | 91-266 406-25  | 24  | 91-043 947-92  |
| 11  | 91-170 364-15  | 25  | 91-043 946-25  |
| 12  | 91-170 363-15  | 26  | 91-000 388-15  |
| 13  | 11-108 174-15  | 27  | 11-470 355-25  |
| 14 - 20                                       | 91-156 269-90  |   |  |

-40/01-900/81;/82 CN8<sup>◆</sup>

Arbeitsgang  
Operation  
Opération  
Opéracion

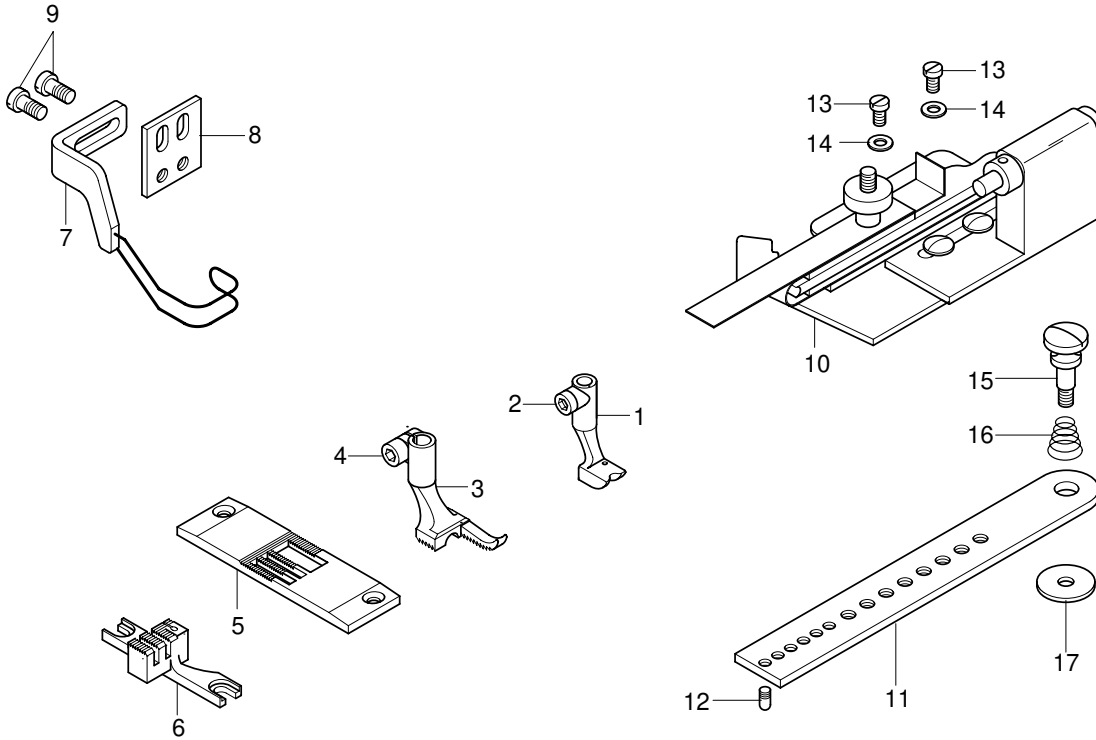
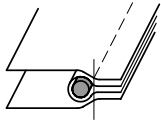

| Pos.-Nr.<br>Item No.<br>N° pos.<br>N° de pos. | Kederdicke<br>Thickness of welting<br>Grosseur du bourrelet<br>Grosor del vivo | Teile-Nr.<br>Part No.<br>N° de piezas<br>N° de pieza  |
|---|--|---|
| 1 - 2   | 4,0<br>5,0<br>5,5<br>6,5<br>7,0<br>8,0<br>10,0                                 | 91-049 382-93/007<br>91-049 382-93/003<br>91-049 382-93/004<br>91-049 382-93/006<br>91-049 382-93/001<br>91-049 382-93/002<br>91-049 382-93/009 |
| 2   |  | 11-132 217-15   |
| 3 - 4   | 4,0<br>5,0<br>5,5<br>6,5<br>7,0<br>8,0<br>10,0                                 | 91-049 989-93/003<br>91-049 989-93/004<br>91-049 989-93/005<br>91-049 989-93/006<br>91-049 989-93/009<br>91-049 989-93/007<br>91-049 989-93/008 |
| 4   |  | 11-130 173-15   |
| 5   |  | 91-150 600-04/001   |
| 6   |  | 91-059 933-04/001   |
| 7 - 9   |  | 91-155 429-91   |
| 7   |  | 91-155 430-91   |

| Pos.-Nr.<br>Item No.<br>N° pos.<br>N° de pos. | Kederdicke<br>Thickness of welting<br>Grosseur du bourrelet<br>Grosor del vivo | Teile-Nr.<br>Part No.<br>N° de piezas<br>N° de pieza  |
|---|--|---|
| 8   |  | 91-057 698-15   |
| 9   |  | 11-130 167-15   |
| 10  | 4,0<br>5,0<br>5,5<br>6,5<br>7,0<br>8,0<br>10,0                                 | 91-156 701-93/002<br>91-156 701-93/003<br>91-156 701-93/004<br>91-156 701-93/005<br>91-156 701-93/005<br>91-156 701-93/006<br>91-156 701-93/008 |
| 11 - 17                                       |  | 91-156 263-90   |
| 11  |  | 91-042 940-25   |
| 12  |  | 91-000 775-15   |
| 13  |  | 91-000 089-15   |
| 14  |  | 12-315 110-15   |
| 15  |  | 91-700 824-25   |
| 16  |  | 91-040 624-25   |
| 17  |  | 91-028 036-25   |



-40/12-900/81;/82 CN8♦

Arbeitsgang  
 Operation  
 Opération  
 Operación

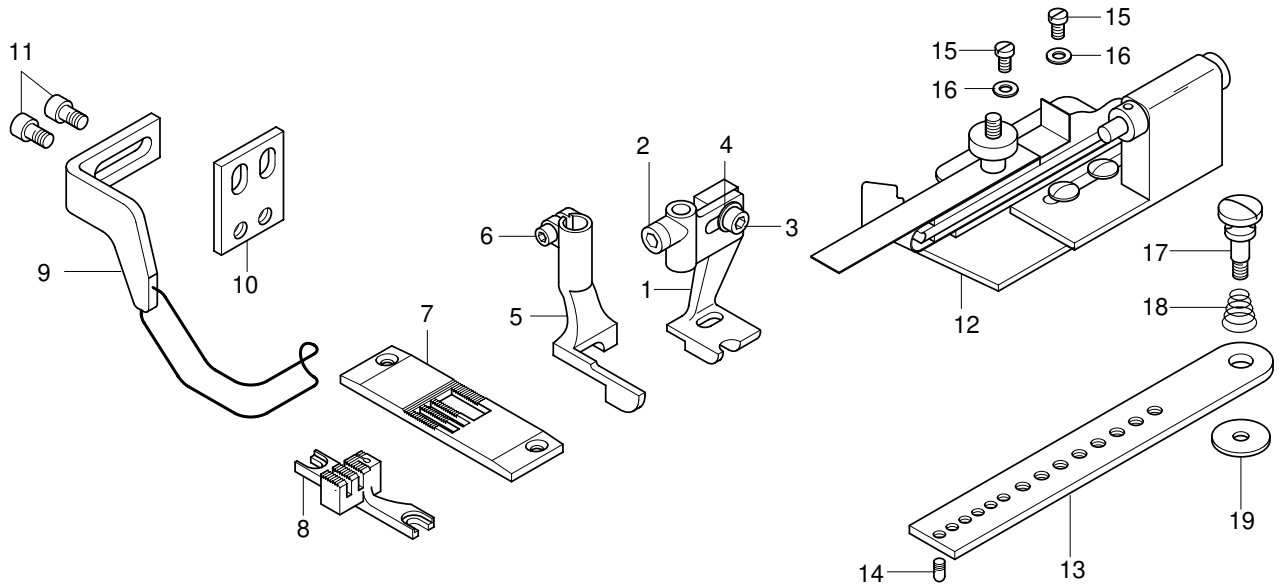
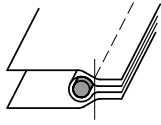

| Pos.-Nr.<br>Item No.<br>N° pos.<br>N° de pos. | Kederdicke<br>Thickness of welting<br>Grosseur du bourrelet<br>Grosor del vivo | Teile-Nr.<br>Part No.<br>N° de piezas<br>N° de pieza   |
|---|--|--|
| 1 - 19  | 5,0<br>6,0<br>7,0<br>9,0   | 91-201 802-93/004<br>91-201 802-93/005<br>91-201 802-93/006<br>91-201 802-93/007   |
| 1 - 4   | 3,0<br>4,0<br>5,0<br>6,0<br>7,0<br>8,0<br>9,0<br>10,0                          | 91-049 402-93/007<br>91-049 402-93/001<br>91-049 402-93/003<br>91-049 402-93/004<br>91-049 402-93/008<br>91-049 402-93/006<br>91-049 402-93/009<br>91-049 402-93/010 |
| 2   |  | 11-132 217-15  |
| 3   |  | 11-130 173-15  |
| 4   |  | 12-315 110-15  |
| 5 - 6   | 3,0<br>4,0<br>5,0<br>6,0<br>7,0<br>8,0<br>9,0<br>10,0                          | 91-049 782-93/007<br>91-049 782-93/001<br>91-049 782-93/003<br>91-049 782-93/004<br>91-049 782-93/008<br>91-049 782-93/006<br>91-049 782-93/009<br>91-049 782-93/010 |
| 6   |  | 11-130 173-15  |
| 7   |  | 91-150 600-04/001  |

| Pos.-Nr.<br>Item No.<br>N° pos.<br>N° de pos. | Kederdicke<br>Thickness of welting<br>Grosseur du bourrelet<br>Grosor del vivo | Teile-Nr.<br>Part No.<br>N° de piezas<br>N° de pieza   |
|---|--|--|
| 8   |  | 91-059 933-04/001  |
| 9 - 11  |  | 91-155 433-91  |
| 9   |  | 91-155 434-91  |
| 10  |  | 91-057 698-15  |
| 11  |  | 11-130 167-15  |
| 12  | 3,0<br>4,0<br>5,0<br>6,0<br>7,0<br>8,0<br>9,0<br>10,0                          | 91-156 701-93/001<br>91-156 701-93/002<br>91-156 701-93/003<br>91-156 701-93/004<br>91-156 701-93/005<br>91-156 701-93/006<br>91-156 701-93/006<br>91-156 701-93/008 |
| 13 - 19                                       |  | 91-156 263-90  |
| 13  |  | 91-042 940-25  |
| 14  |  | 91-000 775-15  |
| 15  |  | 91-000 089-15  |
| 16  |  | 12-315 110-15  |
| 17  |  | 91-700 824-25  |
| 18  |  | 91-040 624-25  |
| 19  |  | 91-028 036-25  |

## -40/14-900/81;/82 BN8♦

Arbeitsgang  
Operation  
Opération  
Opéracion

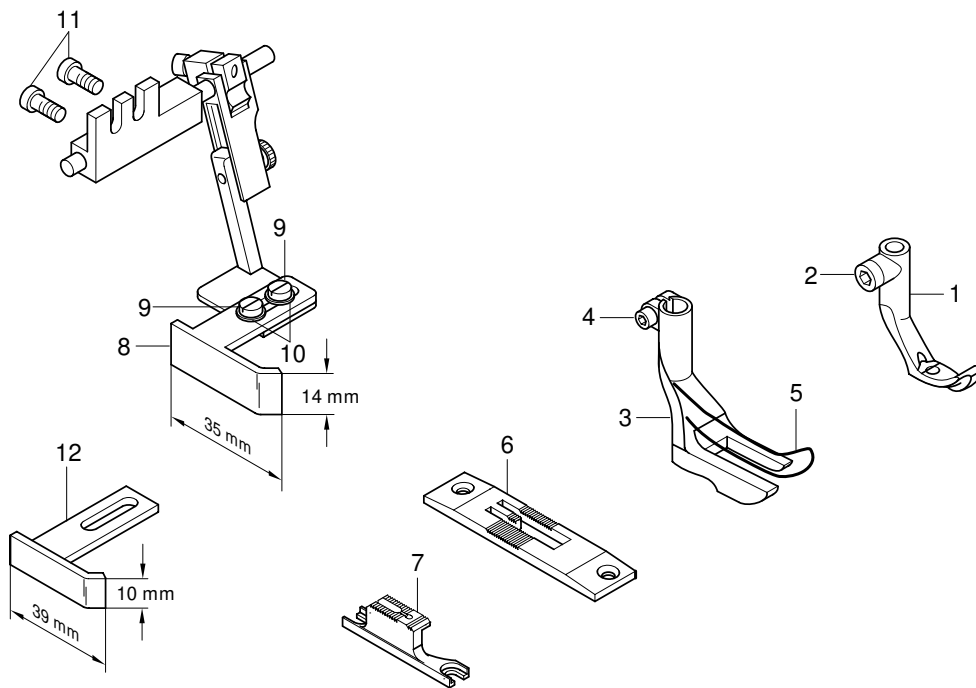
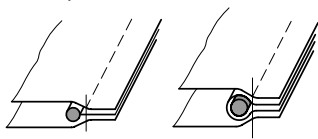

| Pos.-Nr.<br>Item No.<br>N° pos.<br>N° de pos. | Kederdicke<br>Thickness of welting<br>Grosseur du bourrelet<br>Grosor del vivo | Teile-Nr.<br>Part No.<br>N° de pièces<br>N° de piezas   |
|---|--|---|
| 1 - 11  | 5,0<br>7,0<br>9,0  | 91-201 803-93/001<br>91-201 803-93/002<br>91-201 803-93/003   |
| 1 - 2   | 4,0<br>5,0<br>6,0<br>7,0<br>9,0  | 91-049 490-93/004<br>91-049 490-93/003<br>91-049 490-93/003<br>91-049 490-93/003<br>91-049 490-93/003 |
| 2   |  | 11-132 217-15   |
| 3 - 5   | 4,0<br>5,0<br>6,0<br>7,0<br>9,0  | 91-149 169-93/006<br>91-149 169-93/001<br>91-149 169-93/004<br>91-149 169-93/002<br>91-149 169-93/003 |

| Pos.-Nr.<br>Item No.<br>N° pos.<br>N° de pos. | Kederdicke<br>Thickness of welting<br>Grosseur du bourrelet<br>Grosor del vivo | Teile-Nr.<br>Part No.<br>N° de pièces<br>N° de piezas |
|---|--|---|
| 4   |  | 11-130 173-15   |
| 5   |  | 91-149 180-15 <u>3/1</u>                              |
| 6   |  | 91-150 602-05   |
| 7   |  | 91-059 935-04/001                                     |
| 8 - 11  |  | 09-009 824-22   |
| 8   |  | 99-117 869-23   |
| 9   |  | 91-100 120-25   |
| 10  |  | 12-305 114-25   |
| 11  |  | 11-132 223-15   |
| 12  |  | 99-117 868-23   |

-40/14-900/81;/82 CN8♦

Arbeitsgang  
 Operation  
 Opération  
 Operación

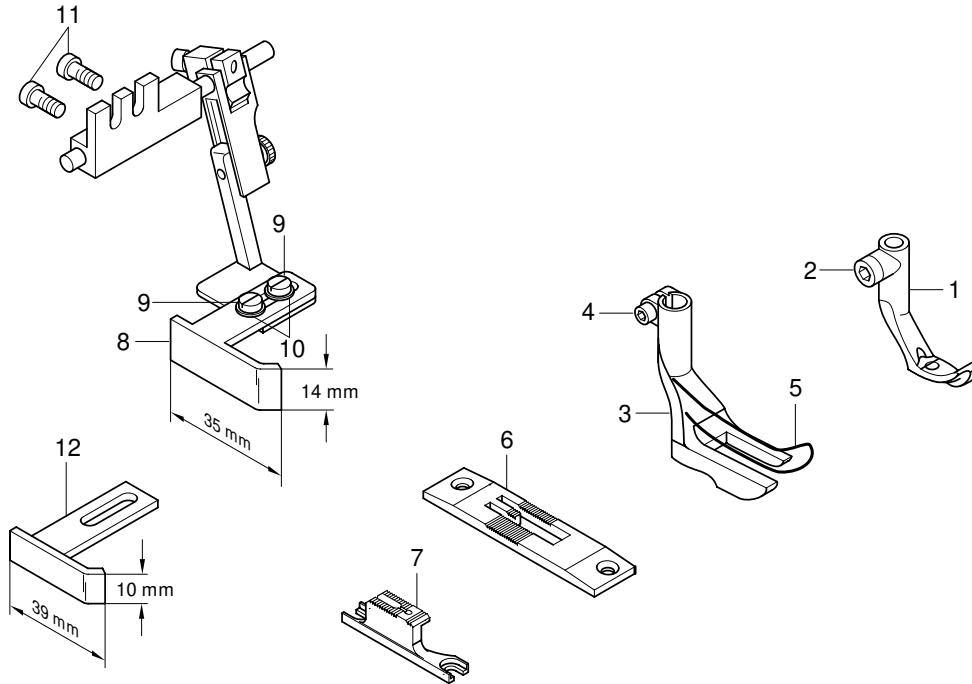
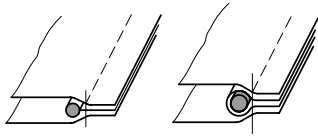

| Pos.-Nr.<br>Item No.<br>N° pos.<br>N° de pos. | Kederdicke<br>Thickness of welting<br>Grosseur du bourrelet<br>Grosor del vivo | Teile-Nr.<br>Part No.<br>N° de piezas<br>N° de pieza   |
|---|--|--|
| 1 - 11  | 5,0<br>6,0<br>7,0<br>9,0   | 91-201 803-93/004<br>91-201 803-93/007<br>91-201 803-93/005<br>91-201 803-93/006   |
| 1 - 2   | 4,0<br>5,0<br>6,0<br>7,0<br>9,0<br>11,0  | 91-049 490-93/401<br>91-049 490-93/001<br>91-049 490-93/001<br>91-049 490-93/001<br>91-049 490-93/001<br>91-049 490-93/002 |
| 2   |  | 11-132 217-15  |
| 3 - 5   | 4,0<br>5,0<br>6,0<br>7,0<br>9,0<br>11,0  | 91-149 169-93/006<br>91-149 169-93/001<br>91-149 169-93/004<br>91-149 169-93/002<br>91-149 169-93/003<br>91-149 169-93/005 |

| Pos.-Nr.<br>Item No.<br>N° pos.<br>N° de pos. | Kederdicke<br>Thickness of welting<br>Grosseur du bourrelet<br>Grosor del vivo | Teile-Nr.<br>Part No.<br>N° de piezas<br>N° de pieza                            |
|---|--|---|
| 4   |  | 11-130 173-15   |
| 5   |  | 91-149 180-15 <span style="border: 1px solid black; padding: 0 2px;">3/1</span> |
| 6   |  | 91-150 602-05   |
| 7   |  | 91-059 935-04/002   |
| 8 - 11  |  | 09-009 824-22   |
| 8   |  | 99-117 869-23   |
| 9   |  | 91-100 120-25   |
| 10  |  | 12-305 114-25   |
| 11  |  | 11-132 223-15   |
| 12  |  | 99-117 868-23   |

-113/05-900/81;/82 BN8♦

Arbeitsgang  
Operation  
Opération  
Opéracion

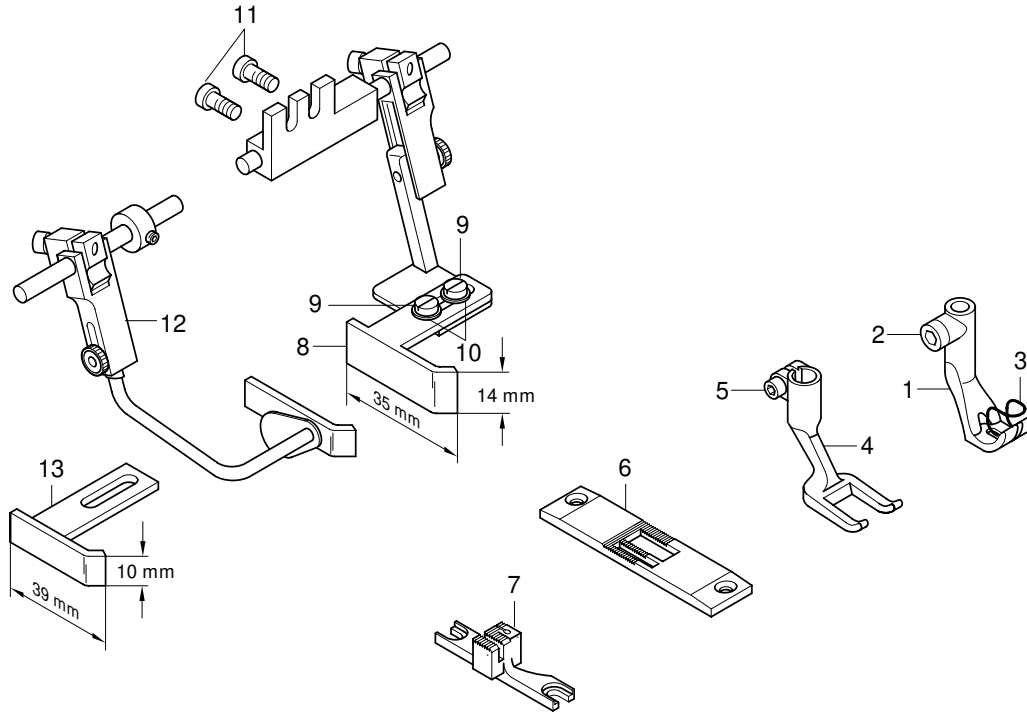
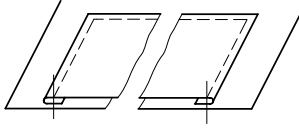

| Pos.-Nr.<br>Item No.<br>N° pos.<br>N° de pos. | Kederdicke<br>Thickness of welting<br>Grosseur du bourrelet<br>Grosor del vivo | Teile-Nr.<br>Part No.<br>N° de piezas<br>N° de pieza |
|---|--|--|
| 1 - 12  | 3,0  | 91-201 804-93/001                                    |
|   | 3,5  | 91-201 804-93/003                                    |
|   | 4,0  | 91-201 804-93/005                                    |
| 1 - 3   | 3,0  | 91-149 174-93/001                                    |
|   | 3,5  | 91-149 174-93/002                                    |
|   | 4,0  | 91-149 174-93/003                                    |
|   | 4,5  | 91-149 174-93/004                                    |
|   | 5,0  | 91-149 174-93/005                                    |
| 2   |  | 11-132 217-15  |
| 3   |  | 91-149 117-05 [3/1]                                  |
| 4 - 5   | 3,0  | 91-149 179-93/013                                    |
|   | 3,5  | 91-149 179-93/015                                    |
|   | 4,0  | 91-049 964-93/004                                    |
|   | 4,5  | 91-049 964-93/005                                    |
|   | 5,0  | 91-049 964-93/006                                    |

| Pos.-Nr.<br>Item No.<br>N° pos.<br>N° de pos. | Kederdicke<br>Thickness of welting<br>Grosseur du bourrelet<br>Grosor del vivo | Teile-Nr.<br>Part No.<br>N° de piezas<br>N° de pieza |
|---|--|--|
| 5   |  | 11-130 173-15  |
| 6   |  | 91-150 600-04/002                                    |
| 7   |  | 91-059 933-04/004                                    |
| 8 - 12  |  | 09-009 842-60  |
| 8 - 11  |  | 09-009 824-22  |
| 8   |  | 99-117 869-23  |
| 9   |  | 91-100 120-25  |
| 10  |  | 12-305 114-25  |
| 11  |  | 11-132 223-15  |
| 12  |  | 09-009 859-87  |
| 13  |  | 99-117 868-23  |

-113/05-900/81;/82 CN8♦

Arbeitsgang  
 Operation  
 Opération  
 Operación

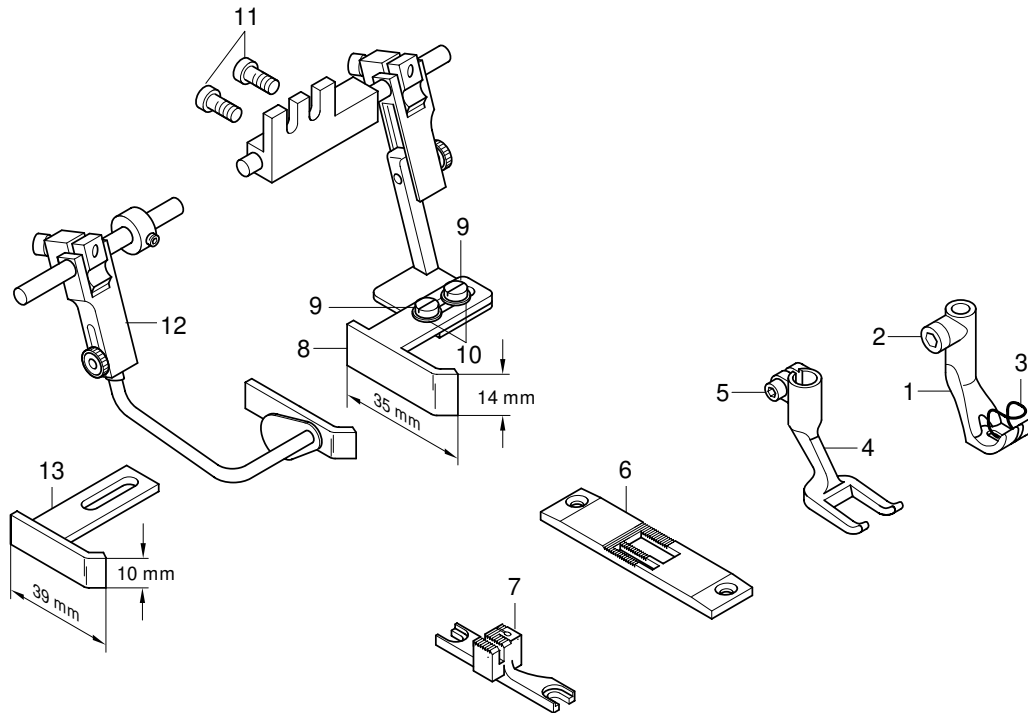
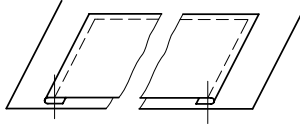

| Pos.-Nr.<br>Item No.<br>N° pos.<br>N° de pos. | Kederdicke<br>Thickness of welting<br>Grosseur du bourrelet<br>Grosor del vivo | Teile-Nr.<br>Part No.<br>N° de piezas<br>N° de pieza  |
|---|--|---|
| 1 - 12  | 3,0<br>3,5<br>4,0  | 91-201 804-93/002<br>91-201 804-93/004<br>91-201 804-93/006   |
| 1 - 3   | 3,0<br>3,5<br>4,0<br>4,5<br>5,0  | 91-149 174-93/006<br>91-149 174-93/007<br>91-149 174-93/008<br>91-149 174-93/009<br>91-149 174-93/010 |
| 2   |  | 11-132 217-15   |
| 3   |  | 91-149 117-05 <span style="border: 1px solid black; padding: 0 2px;">3/1</span>                       |
| 4 - 5   | 3,0<br>3,5<br>4,0<br>4,5<br>5,0  | 91-149 179-93/014<br>91-149 179-93/016<br>91-049 964-93/001<br>91-049 964-93/002<br>91-049 964-93/003 |

| Pos.-Nr.<br>Item No.<br>N° pos.<br>N° de pos. | Kederdicke<br>Thickness of welting<br>Grosseur du bourrelet<br>Grosor del vivo | Teile-Nr.<br>Part No.<br>N° de piezas<br>N° de pieza |
|---|--|--|
| 5   |  | 11-130 173-15  |
| 6   |  | 91-150 600-04/002                                    |
| 7   |  | 91-059 933-04/005                                    |
| 8 - 12  |  | 09-009 842-60  |
| 8 - 11  |  | 09-009 824-22  |
| 8   |  | 99-117 869-23  |
| 9   |  | 91-100 120-25  |
| 10  |  | 12-305 114-25  |
| 11  |  | 11-132 223-15  |
| 12  |  | 09-009 859-87  |
| 13  |  | 99-117 868-23  |

-731/02-6/01-900/81;/82 BN8♦

Arbeitsgang  
Operation  
Opération  
Operación

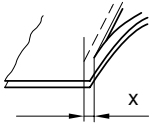

x = 3,5; 4,0; 5,0 mm  
5,0 mm = Standard  
5,0 mm = standard  
5,0 mm = standard  
5,0 mm = estándar

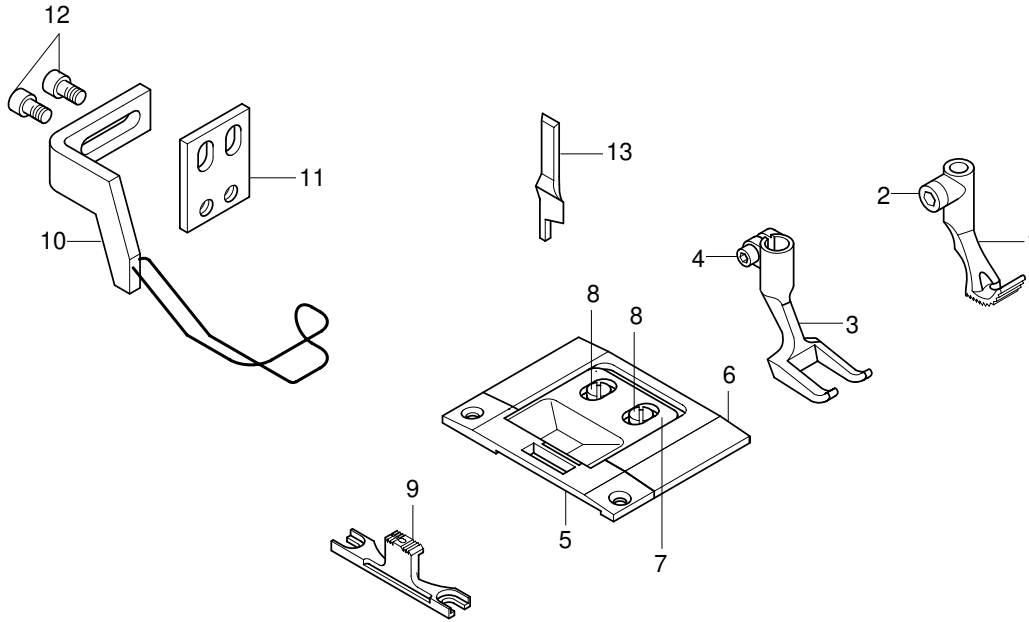

| Pos.-Nr.<br>Item No.<br>N° pos.<br>N° de pos. | Schneidabstand<br>Trimming margin<br>Distance de coupe<br>Margen de corte | Teile-Nr.<br>Part No.<br>N° de piezas<br>N° de pieza        |
|---|---|---|
| 1 - 13  | 3,5   | 91-201 810-93/001   |
| 1 - 2   | 3,5<br>4,0<br>5,0   | 91-149 039-93/007<br>91-149 039-93/005<br>91-149 039-93/006 |
| 2   |   | 11-132 217-15   |
| 3 - 4   | 3,5<br>4,0<br>5,0   | 91-149 177-93/001<br>91-149 177-93/002<br>91-149 177-93/004 |
| 4   |   | 11-130 173-15   |
| 5 - 8   | 3,5<br>4,0<br>5,0   | 91-150 615-93/001<br>91-150 615-93/002<br>91-150 615-93/004 |
| 5   | 3,5<br>4,0  | 91-150 616-93/001<br>91-150 616-93/002                      |

| Pos.-Nr.<br>Item No.<br>N° pos.<br>N° de pos. | Schneidabstand<br>Trimming margin<br>Distance de coupe<br>Margen de corte | Teile-Nr.<br>Part No.<br>N° de piezas<br>N° de pieza        |
|---|---|---|
|   | 5,0   | 91-150 616-93/004   |
| 6   |   | 91-150 130-05   |
| 7   |   | 91-150 133-01   |
| 8   |   | 91-100 293-25   |
| 9   |   | 91-059 940-04/002   |
| 10 - 12                                       |   | 91-154 633-91   |
| 10  |   | 91-154 634-91   |
| 11  |   | 91-057 698-15   |
| 12  |   | 11-130 167-15   |
| 13  | 3,5<br>4,0<br>5,0   | 91-166 700-04/003<br>91-166 700-04/003<br>91-166 701-04/005 |

-731/02-6/01-900/81;/82 CN8♦

Arbeitsgang  
 Operation  
 Opération  
 Operación

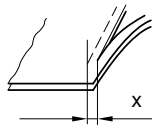

x = 3,5; 5,0; 6,0; 8,0 mm  
 5,0 mm = Standard  
 5,0 mm = standard  
 5,0 mm = standard  
 5,0 mm = estándar

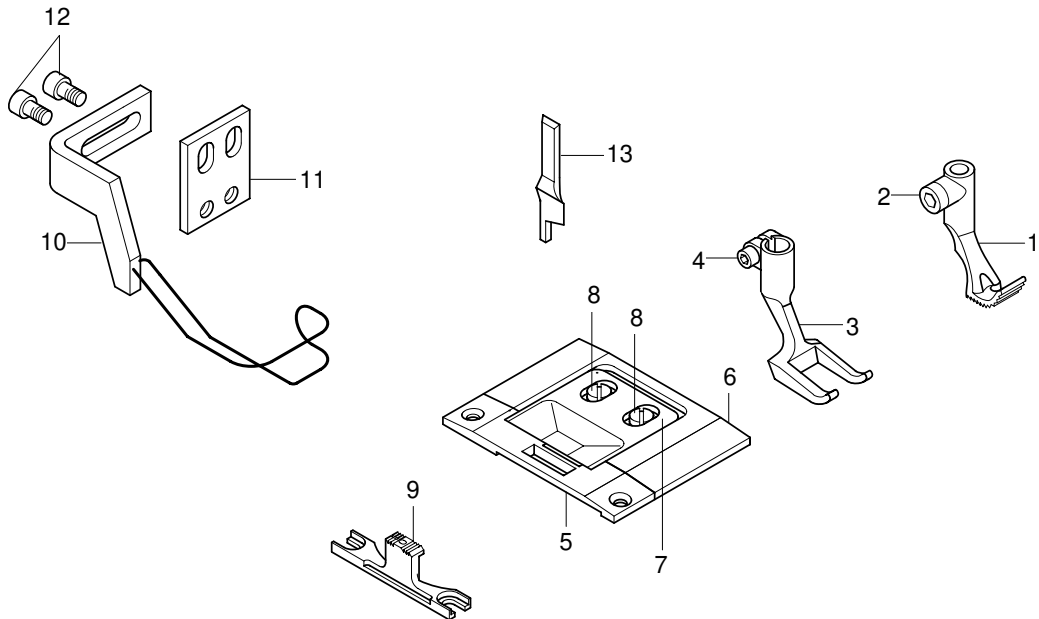

| Pos.-Nr.<br>Item No.<br>N° pos. | Schneidabstand<br>Trimming margin<br>Distance de coupe<br>Margen de corte | Teile-Nr.<br>Part No.<br>N° de piezas<br>N° de pieza                             |
|---------------------------------|---|--|
| 1 - 13                          | 3,5<br>5,0<br>6,0<br>8,0  | 91-201 810-93/002<br>91-201 810-93/003<br>91-201 810-93/001<br>91-201 810-93/004 |
| 1 - 2                           | 3,5<br>5,0<br>6,0<br>8,0  | 91-149 039-93/008<br>91-149 039-93/002<br>91-149 039-93/004<br>91-149 039-93/003 |
| 2                               |   | 11-132 217-15  |
| 3 - 4                           | 3,5<br>5,0<br>6,0<br>8,0  | 91-149 177-93/011<br>91-149 177-93/014<br>91-149 177-93/016<br>91-149 177-93/020 |
| 4                               |   | 11-130 173-15  |
| 5 - 8                           | 3,5<br>5,0<br>6,0<br>8,0  | 91-150 615-93/001<br>91-150 615-93/004<br>91-150 615-93/006<br>91-150 615-93/010 |

| Pos.-Nr.<br>Item No.<br>N° pos. | Schneidabstand<br>Trimming margin<br>Distance de coupe<br>Margen de corte | Teile-Nr.<br>Part No.<br>N° de piezas<br>N° de pieza                             |
|---------------------------------|---|--|
| 5                               | 3,5<br>5,0<br>6,0<br>8,0  | 91-150 616-93/001<br>91-150 616-93/004<br>91-150 616-93/006<br>91-150 616-93/010 |
| 6                               |   | 91-150 130-05  |
| 7                               |   | 91-150 133-01  |
| 8                               |   | 91-100 293-25  |
| 9                               | 3,5; 5,0; 6,0<br>8,0  | 91-059 940-04/003<br>91-059 940-04/006   |
| 10 - 12                         |   | 91-154 633-91  |
| 10                              |   | 91-154 634-91  |
| 11                              |   | 91-057 698-15  |
| 12                              |   | 11-130 167-15  |
| 13                              | 3,5<br>5,0; 6,0<br>8,0  | 91-166 700-04/002<br>91-166 701-04/005<br>91-166 701-04/006                      |

-2/08-900/81;/82 CN8♦

Für allgemeine Näharbeiten.  
 Standardform des Teilesatzes.  
 Lineal hochklappbar.

Für allgemeine Näharbeiten.  
 Standardform des Teilesatzes.  
 Lineal hochklappbar.

Für allgemeine Näharbeiten.  
 Standardform des Teilesatzes.  
 Lineal hochklappbar.

Für allgemeine Näharbeiten.  
 Standardform des Teilesatzes.  
 Lineal hochklappbar.

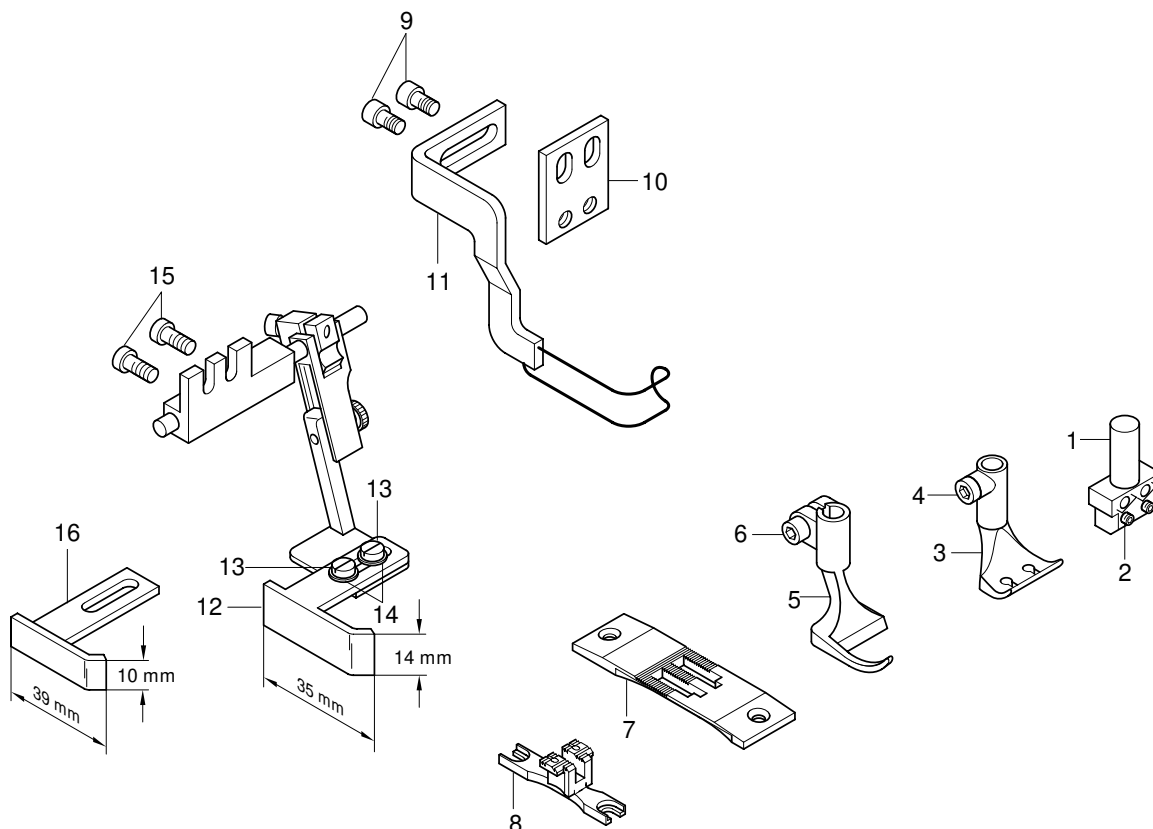

| Pos.-Nr.<br>Item No.<br>N° pos.<br>N° de pos. | Nadelabstand<br>Needle gauge<br>Ecartement de aiguilles<br>Dist. entre aguja | Teile-Nr.<br>Part No.<br>N° de piezas<br>N° de pieza |
|---|--|--|
| 1 - 15  | 4,8  | 91-201 785-93/001                                    |
| 1 - 2   | 4,8  | 91-172 590-93/003                                    |
| 2   |  | 11-330 082-15  |
| 3 - 4   | 4,8  | 91-049 472-93/004                                    |
| 4   |  | 11-132 217-15  |
| 5 - 6   | 4,8  | 91-049 846-93/004                                    |
| 6   |  | 11-130 173-15  |
| 7   | 4,8  | 91-150 619-04/003                                    |
| 8   | 4,8  | 91-059 942-04/018                                    |
| 9 - 11  |  | 91-155 426-91  |

| Pos.-Nr.<br>Item No.<br>N° pos.<br>N° de pos. | Nadelabstand<br>Needle gauge<br>Ecartement de aiguilles<br>Dist. entre aguja | Teile-Nr.<br>Part No.<br>N° de piezas<br>N° de pieza |
|---|--|--|
| 9   |  | 11-130 167-15  |
| 10  |  | 91-057 698-15  |
| 11  |  | 91-155 427-91  |
| 12 - 15                                       |  | 09-009 824-22  |
| 12  |  | 99-117 869-23  |
| 13  |  | 91-100 120-25  |
| 14  |  | 12-305 114-25  |
| 15  |  | 11-132 223-15  |
| 16  |  | 99-117 868-23  |



-6/01-900/81;/82 BN8♦

Für allgemeine Näharbeiten.  
 Standardform des Teilesatzes.

Für allgemeine Näharbeiten.  
 Standardform des Teilesatzes.

Für allgemeine Näharbeiten.  
 Standardform des Teilesatzes.

Für allgemeine Näharbeiten.  
 Standardform des Teilesatzes.

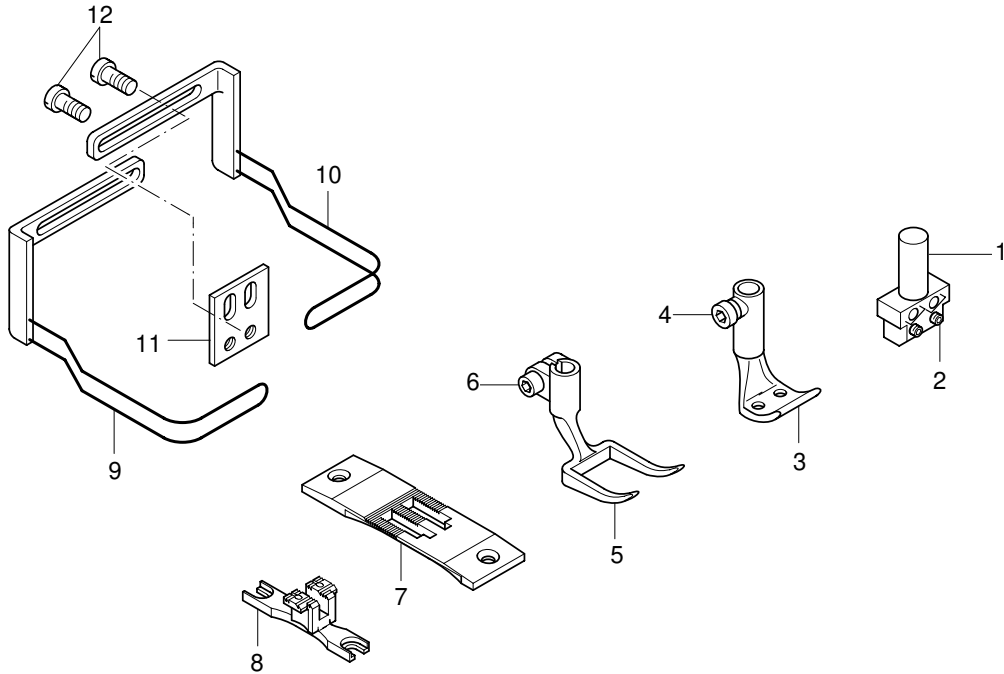

| Pos.-Nr.<br>Item No.<br>N° pos.<br>N° de pos. | Nadelabstand<br>Needle gauge<br>Ecartement de aiguilles<br>Dist. entre aguja | Teile-Nr.<br>Part No.<br>N° de piezas<br>N° de pieza  |
|---|--|---|
| 1 - 12  | 2,4<br>4,8<br>6,0<br>8,0<br>22,0   | 91-201 760-93/016<br>91-201 760-93/001<br>91-201 760-93/002<br>91-201 760-93/018<br>91-201 760-93/019 |
| 1 - 2   | 2,4<br>4,8<br>6,0<br>8,0<br>22,0   | 91-176 068-93/001<br>91-172 590-93/003<br>91-172 590-93/005<br>91-172 840-93/002<br>91-172 840-93/012 |
| 2   |  | 11-330 082-15   |
| 3 - 4   | 2,4<br>4,8<br>6,0<br>8,0<br>22,0   | 91-049 385-93/021<br>91-049 385-93/026<br>91-049 385-93/028<br>91-049 385-93/034<br>91-049 385-93/011 |
| 4   |  | 11-132 217-15   |
| 5 - 6   | 2,4<br>4,8<br>6,0<br>8,0<br>22,0   | 91-149 179-93/017<br>91-149 179-93/002<br>91-149 179-93/003<br>91-149 179-93/004<br>91-149 179-93/025 |
| 6   |  | 11-130 173-15   |
| 7   | 2,4  | 91-150 619-04/020   |

| Pos.-Nr.<br>Item No.<br>N° pos.<br>N° de pos. | Nadelabstand<br>Needle gauge<br>Ecartement de aiguilles<br>Dist. entre aguja | Teile-Nr.<br>Part No.<br>N° de piezas<br>N° de pieza  |
|---|--|---|
|   | 4,8<br>6,0<br>8,0<br>22,0  | 91-150 619-04/002<br>91-150 619-04/001<br>91-150 619-04/005<br>91-150 619-04/009                      |
| 8   | 2,4<br>4,8<br>6,0<br>8,0<br>22,0   | 91-059 942-04/015<br>91-059 942-04/002<br>91-059 942-04/003<br>91-059 942-04/019<br>91-059 942-04/027 |
| 9 - 12  | 2,4<br>4,8<br>6,0<br>8,0<br>22,0   | 91-154 696-91<br>91-154 699-91<br>91-154 699-91<br>91-154 699-91<br>91-154 706-91                     |
| 9   | 2,4<br>4,8<br>6,0<br>8,0<br>22,0   | 91-154 697-91<br>91-154 700-91<br>91-154 700-91<br>91-154 700-91<br>91-154 707-91                     |
| 10  | 4,8<br>6,0<br>8,0<br>22,0  | 91-154 703-91<br>91-154 703-91<br>91-154 703-91<br>91-154 709-91                                      |
| 11  |  | 91-057 698-15   |
| 12  |  | 11-108 174-15   |

-6/01-900/81;/82 CN8<sup>◆</sup>

Für allgemeine Näharbeiten.  
Standardform des Teilesatzes.

Für allgemeine Näharbeiten.  
Standardform des Teilesatzes.

Für allgemeine Näharbeiten.  
Standardform des Teilesatzes.

Für allgemeine Näharbeiten.  
Standardform des Teilesatzes.

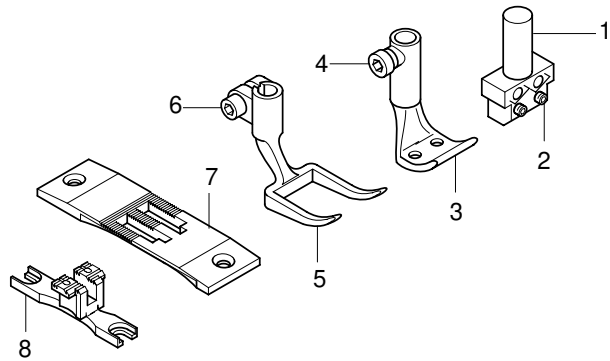
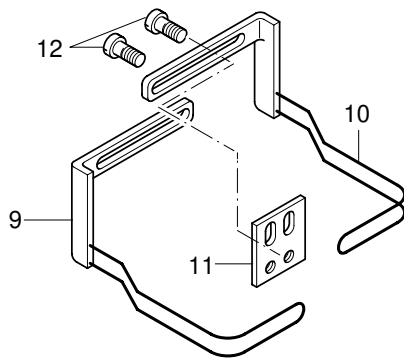

| Pos.-Nr.<br>Item No.<br>N° pos.<br>N° de pos. | Nadelnabstand<br>Needle gauge<br>Ecartement de aiguilles<br>Dist. entre aguja                   | Teile-Nr.<br>Part No.<br>N° de pièces<br>N° de pieza  |
|---|---|---|
| 1 - 12  | 4,8<br>6,0<br>6,4<br>7,2<br>8,0<br>10,0<br>12,0<br>15,2<br>16,0<br>18,0<br>19,2<br>22,0<br>24,0 | 91-201 760-93/022<br>91-201 760-93/013<br>91-201 760-93/003<br>91-201 760-93/012<br>91-201 760-93/009<br>91-201 760-93/004<br>91-201 760-93/014<br>91-201 760-93/017<br>91-201 760-93/005<br>91-201 760-93/020<br>91-201 760-93/021<br>91-201 760-93/011<br>91-201 760-93/006 |
| 1 - 2   | 4,8<br>6,0<br>6,4<br>7,2<br>8,0<br>10,0<br>12,0<br>15,2<br>16,0<br>18,0<br>19,2<br>22,0<br>24,0 | 91-172 590-93/003<br>91-172 590-93/005<br>91-172 590-93/001<br>91-172 590-93/002<br>91-172 840-93/002<br>91-172 840-93/004<br>91-172 840-93/006<br>91-172 840-93/034<br>91-172 840-93/009<br>91-172 840-93/010<br>91-172 840-93/032<br>91-172 840-93/012<br>91-172 840-93/026 |
| 2   |   | 11-330 082-15   |
| 3 - 4   | 4,8<br>6,0<br>6,4<br>7,2<br>8,0<br>10,0<br>12,0<br>15,2<br>16,0<br>18,0<br>19,2<br>22,0<br>24,0 | 91-049 385-93/027<br>91-049 385-93/029<br>91-049 385-93/031<br>91-049 385-93/033<br>91-049 385-93/035<br>91-049 385-93/039<br>91-049 385-93/002<br>91-049 385-93/044<br>91-049 385-93/006<br>91-049 385-93/008<br>91-049 385-93/057<br>91-049 385-93/012<br>91-049 385-93/014 |
| 4   |   | 11-132 217-15   |
| 5 - 6   | 4,8<br>6,0; 6,4<br>7,2; 8,0<br>10,0<br>12,0<br>15,2<br>16,0                                     | 91-149 179-93/011<br>91-149 179-93/001<br>91-149 179-93/005<br>91-149 179-93/007<br>91-149 179-93/012<br>91-149 179-93/019<br>91-149 179-93/008   |

| Pos.-Nr.<br>Item No.<br>N° pos.<br>N° de pos. | Nadelnabstand<br>Needle gauge<br>Ecartement de aiguilles<br>Dist. entre aguja                   | Teile-Nr.<br>Part No.<br>N° de pièces<br>N° de pieza  |
|---|---|---|
|   | 18,0<br>19,2<br>22,0<br>24,0  | 91-149 179-93/020<br>91-149 179-93/021<br>91-149 179-93/009<br>91-149 179-93/010  |
| 6   |   | 11-130 173-15   |
| 7   | 4,8<br>6,0; 6,4<br>7,2; 8,0<br>10,0<br>12,0<br>15,2<br>16,0<br>18,0<br>19,2<br>22,0<br>24,0     | 91-150 619-04/003<br>91-150 619-04/004<br>91-150 619-04/005<br>91-150 619-04/007<br>91-150 619-04/019<br>91-150 619-04/021<br>91-150 619-04/008<br>91-150 619-04/023<br>91-150 619-04/024<br>91-150 619-04/009<br>91-150 619-04/010   |
| 8   | 4,8<br>6,0<br>6,4<br>7,2<br>8,0<br>10,0<br>12,0<br>15,2<br>16,0<br>18,0<br>19,2<br>22,0<br>24,0 | 91-059 942-04/018<br>91-059 942-04/001<br>91-059 942-04/004<br>91-059 942-04/005<br>91-059 942-04/006<br>91-059 942-04/007<br>91-059 942-04/013<br>91-059 942-04/016<br>91-059 942-04/008<br>91-059 942-04/021<br>91-059 942-04/022<br>91-059 942-04/009<br>91-059 942-04/010 |
| 9 - 12  | 4,8; 6,0; 6,4; 7,2; 8,0<br>10,0; 12,0; 15,2<br>16,0; 18,0; 19,2;<br>22,0; 24,0                  | 91-154 699-91<br>91-154 706-91  |
| 9   | 4,8; 6,0; 6,4; 7,2; 8,0<br>10,0; 12,0; 15,2<br>16,0; 18,0; 19,2;<br>22,0; 24,0                  | 91-154 700-91<br>91-154 707-91  |
| 10  | 4,8; 6,0; 6,4; 7,2; 8,0<br>10,0; 12,0; 15,2<br>16,0; 18,0; 19,2;<br>22,0; 24,0                  | 91-154 703-91<br>91-154 709-91  |
| 11  |   | 91-057 698-15   |
| 12  |   | 11-108 174-15   |

-63/14-900/81;/82 CN8♦

Arbeitsgang  
 Operation  
 Opération  
 Opéración

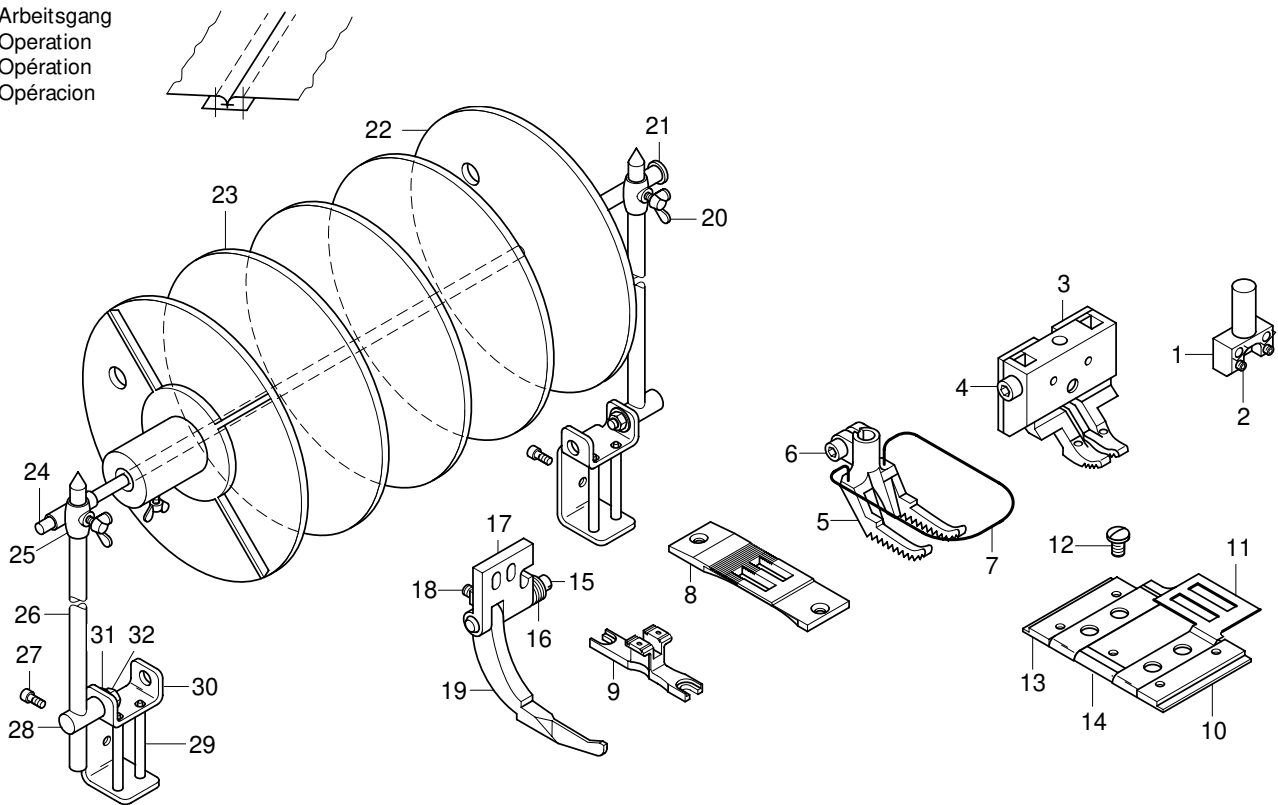

| Pos.-Nr.<br>Item No.<br>N° pos.<br>N° de pos. | Nadelnabstand<br>Needle gauge<br>Ecartement de aiguilles<br>Dist. entre aguja | Teile-Nr.<br>Part No.<br>N° de piezas<br>N° de pieza                             |
|---|---|--|
| 1 - 32  | 8,0<br>10,0<br>12,0<br>14,0   | 91-201 762-93/001<br>91-201 762-93/002<br>91-201 762-93/004<br>91-201 762-93/005 |
| 1 - 2   | 8,0<br>10,0<br>12,0<br>14,0   | 91-172 840-93/002<br>91-172 840-93/004<br>91-172 840-93/006<br>91-172 840-93/008 |
| 2   |   | 11-330 085-15  |
| 3 - 4   | 8,0<br>10,0<br>12,0<br>14,0   | 91-149 152-93/003<br>91-149 152-93/001<br>91-149 152-93/004<br>91-149 152-93/009 |
| 4   |   | 11-130 185-15  |
| 5 - 7   | 8,0<br>10,0<br>12,0<br>14,0   | 91-049 988-93/002<br>91-049 988-93/001<br>91-049 988-93/003<br>91-049 988-93/004 |
| 6   |   | 11-130 173-15  |
| 7   |   | 91-049 982-04/001 [3/1]  |
| 8   | 8,0<br>10,0<br>12,0<br>14,0   | 91-150 597-04/002<br>91-150 597-04/001<br>91-150 597-04/003<br>91-150 597-04/004 |
| 9   | 8,0<br>10,0   | 91-059 931-04/002<br>91-059 931-04/003   |

| Pos.-Nr.<br>Item No.<br>N° pos.<br>N° de pos. | Nadelnabstand<br>Needle gauge<br>Ecartement de aiguilles<br>Dist. entre aguja | Teile-Nr.<br>Part No.<br>N° de piezas<br>N° de pieza |
|---|---|--|
|   | 12,0<br>14,0  | 91-059 931-04/004<br>91-059 931-04/005               |
| 10 - 14                                       |   | 91-156 679 -71/895                                   |
| 10  |   | 91-156 680-75/895                                    |
| 11  |   | 91-156 681-25  |
| 12  |   | 91-701 344-25  |
| 13  |   | 91-156 682-25  |
| 14  |   | 91-156 687-25  |
| 15 - 19                                       |   | 91-156 694-91  |
| 15  |   | 91-156 697-05  |
| 16  |   | 91-175 623-05  |
| 17  |   | 91-156 696-15  |
| 18  |   | 11-335 184-15  |
| 19  |   | 91-156 695-15  |
| 20 - 32                                       |   | 91-156 556-71/895                                    |
| 20  |   | 11-505 292-25  |
| 21  |   | 91-046 252-21  |
| 22  |   | 91-056 824-75/895                                    |
| 23  |   | 91-056 825-05  |
| 24  |   | 91-043 145-25  |
| 25  |   | 91-043 155-75/895                                    |
| 26  |   | 91-056 642-25  |
| 27  |   | 96-710 374-15  |
| 28  |   | 91-156 259-15  |
| 29  |   | 91-156 257-15  |
| 30  |   | 91-156 256-15  |
| 31  |   | 12-305 264-15  |
| 32  |   | 12-024 231-15  |

-230/21-900/81;/82 BN♦

Arbeitsgang  
 Operation  
 Opération  
 Opéracion

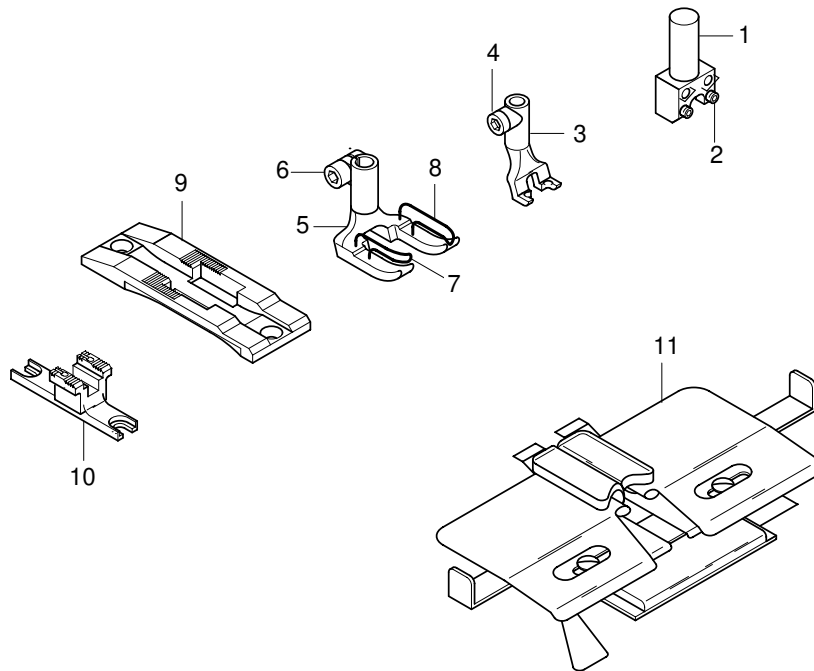
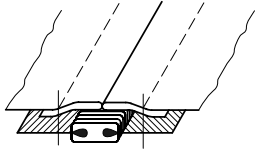

| Pos.-Nr.<br>Item No.<br>N° pos. | Nadelabstand<br>Needle gauge<br>Ecartement de aiguilles<br>Dist. entre aguja | Teile-Nr.<br>Part No.<br>N° de piezas |
|---------------------------------|--|---------------------------------------|
| 1 - 11                          | 12,0   | 91-201 763-93/002                     |
| 1 - 2                           | 12,0   | 91-172 840-93/006                     |
| 2                               |  | 11-330 085-15                         |
| 3 - 4                           | 12,0   | 91-049 387-93/011                     |
| 4                               |  | 11-132 217-15                         |
| 5 - 8                           | 12,0   | 91-049 775-93/004                     |

| Pos.-Nr.<br>Item No.<br>N° pos. | Nadelabstand<br>Needle gauge<br>Ecartement de aiguilles<br>Dist. entre aguja | Teile-Nr.<br>Part No.<br>N° de piezas   |
|---------------------------------|--|---|
| 6                               |  | 11-130 173-15   |
| 7                               |  | 91-055 327-05 <span style="border: 1px solid black; padding: 0 2px;">3/1</span> |
| 8                               |  | 91-055 328-05 <span style="border: 1px solid black; padding: 0 2px;">3/1</span> |
| 9                               |  | 91-150 187-04/005   |
| 10                              |  | 91-059 304-04/003   |
| 11                              |  | 91-156 268-73/002   |

-230/21-900/81;/82 CN♦

Arbeitsgang  
 Operation  
 Opération  
 Operación

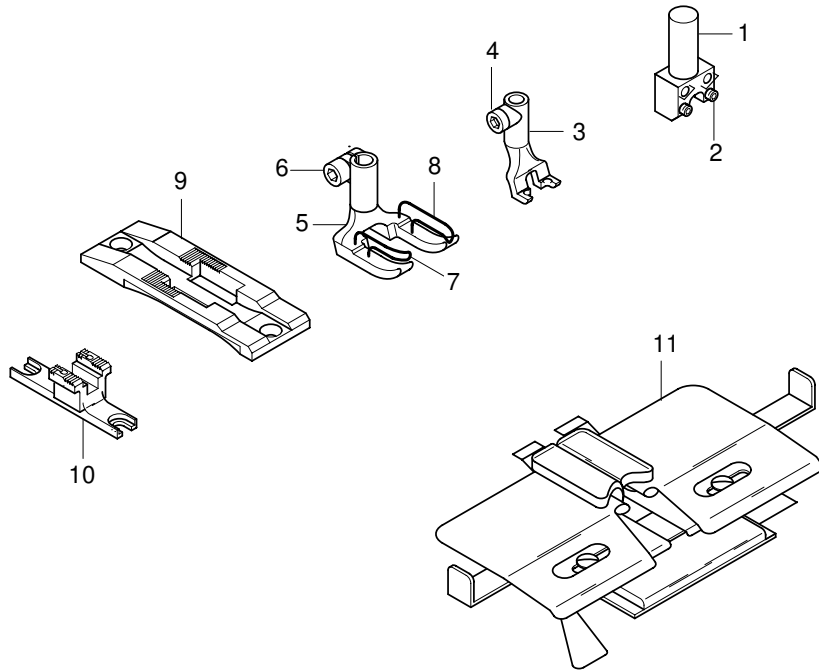
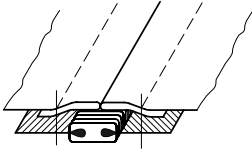

| Pos.-Nr.<br>Item No.<br>N° pos.<br>N° de pos. | Nadelabstand<br>Needle gauge<br>Ecartement de aiguilles<br>Dist. entre aguja | Teile-Nr.<br>Part No.<br>N° de piezas<br>N° de pieza |
|---|--|--|
| 1 - 11  | 12,0   | 91-201 763-93/001                                    |
| 1 - 2   | 12,0   | 91-172 840-93/006                                    |
| 2   |  | 11-330 085-15  |
| 3 - 4   | 12,0   | 91-049 387-93/004                                    |
| 4   |  | 11-132 217-15  |
| 5 - 8   | 12,0   | 91-049 775-93/004                                    |

| Pos.-Nr.<br>Item No.<br>N° pos.<br>N° de pos. | Nadelabstand<br>Needle gauge<br>Ecartement de aiguilles<br>Dist. entre aguja | Teile-Nr.<br>Part No.<br>N° de piezas<br>N° de pieza |
|---|--|--|
| 6   |  | 11-130 173-15  |
| 7   |  | 91-055 327-05 [3/1]                                  |
| 8   |  | 91-055 328-05 [3/1]                                  |
| 9   |  | 91-150 187-04/005                                    |
| 10  |  | 91-059 304-04/004                                    |
| 11  |  | 91-156 268-73/002                                    |

-237/06-900/81;/82 BN♦

Arbeitsgang  
 Operation  
 Opération  
 Operación

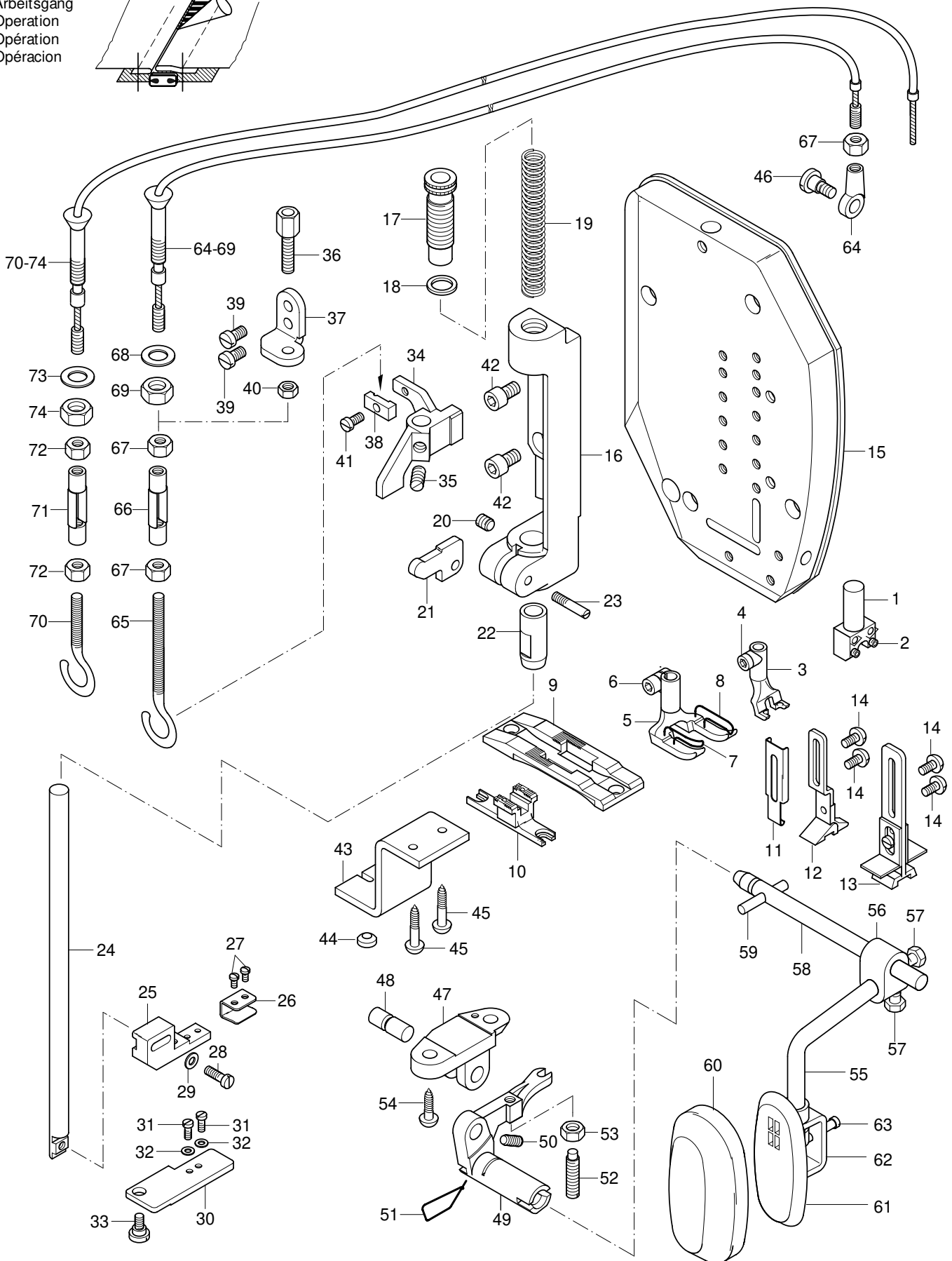
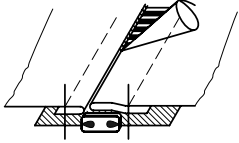

| Pos.-Nr.<br>Item No.<br>N° pos.<br>N° de pos. | Nadelnstand<br>Needle gauge<br>Ecartement de aiguilles<br>Dist. entre aguja | Teile-Nr.<br>Part No.<br>N° de piezas<br>N° de pieza                            | Pos.-Nr.<br>Item No.<br>N° pos.<br>N° de pos. | Nadelnstand<br>Needle gauge<br>Ecartement de aiguilles<br>Dist. entre aguja | Teile-Nr.<br>Part No.<br>N° de piezas<br>N° de pieza |
|---|---|---|---|---|--|
| 1 - 14  | 12,0  | 91-201 764-93/001   | 40  |   | 12-005 175-25  |
| 1 - 2   | 12,0  | 91-172 840-93/006   | 41  |   | 11-108 174-15  |
| 2   |   | 11-330 085-15   | 42  |   | 11-130 284-15  |
| 3 - 4   | 12,0  | 91-049 387-93/011   | 43 - 69                                       |   | 91-027 380-70  |
| 4   |   | 11-132 217-15   | 43  |   | 91-027 383-15  |
| 5 - 8   | 12,0  | 91-049 775-93/004   | 44  |   | 91-027 384-15  |
| 6   |   | 11-130 173-15   | 45  |   | 11-460 250-15  |
| 7   |   | 91-055 327-05 <span style="border: 1px solid black; padding: 0 2px;">3/1</span> | 46  |   | 11-187 019-15  |
| 8   |   | 91-055 328-05 <span style="border: 1px solid black; padding: 0 2px;">3/1</span> | 47 - 53                                       |   | 91-168 370-71/951                                    |
| 9   |   | 91-150 187-04/005   | 47  |   | 91-168 371-75/951                                    |
| 10  |   | 91-059 304-04/003   | 48  |   | 91-168 372-05  |
| 11  |   | 91-056 031-15   | 49  |   | 91-168 373-15  |
| 12  |   | 91-056 026-13/002   | 50  |   | 11-335 902-15  |
| 13  |   | 91-056 033-13/002   | 51  |   | 91-168 331-05  |
| 14  |   | 91-000 335-15   | 52  |   | 11-305 305-15  |
| 15 - 42                                       |   | 91-176 450-71/893   | 53  |   | 12-005 195-15  |
| 15  |   | 91-166 200-75/893   | 54  |   | 11-460 295-15  |
| 16  |   | 91-009 525-75/895   | 55 - 63                                       |   | 91-027 380-71/893                                    |
| 17  |   | 91-000 392-15   | 55  |   | 91-027 289-15  |
| 18  |   | 91-006 526-15   | 56 - 57                                       |   | 91-069 335-72/893                                    |
| 19  |   | 91-007 054-05   | 57  |   | 11-039 360-15  |
| 20  |   | 91-000 152-15   | 58  |   | 91-027 382-15  |
| 21  |   | 91-108 586-15   | 59  |   | 13-052 256-15  |
| 22  |   | 91-009 527-05   | 60  |   | 91-029 692-75/792                                    |
| 23  |   | 91-000 469-15   | 61  |   | 91-027 370-05  |
| 24  |   | 91-014 429-01   | 62 - 63                                       |   | 91-027 371-12  |
| 25  |   | 91-108 587-15   | 63  |   | 11-174 233-15  |
| 26  |   | 91-108 588-15   | 64 - 69                                       |   | 91-108 595-71/895                                    |
| 27  |   | 91-000 091-15   | 64  |   | 91-140 617-75/895                                    |
| 28  |   | 11-108 180-15   | 65  |   | 91-108 596-15  |
| 29  |   | 12-305 114-15   | 66  |   | 91-010 643-05  |
| 30  |   | 91-176 451-15   | 67  |   | 91-001 513-15  |
| 31  |   | 11-108 096-15   | 68  |   | 91-028 953-15  |
| 32  |   | 12-305 084-15   | 69  |   | 12-024 211-15  |
| 33  |   | 91-000 565-15   | 70 - 74                                       |   | 91-174 259-91  |
| 34  |   | 91-174 243-15   | 70  |   | 91-010 644-15  |
| 35  |   | 91-000 510-15   | 71  |   | 91-010 643-05  |
| 36  |   | 99-133 259-25   | 72  |   | 91-001 513-15  |
| 37  |   | 91-174 244-15   | 73  |   | 91-028 953-15  |
| 38  |   | 91-174 245-15   | 74  |   | 12-024 211-15  |
| 39  |   | 11-108 222-15   |   |   |  |

-237/10-900/81;/82 BN♦

Arbeitsgang  
 Operation  
 Opération  
 Opéracion

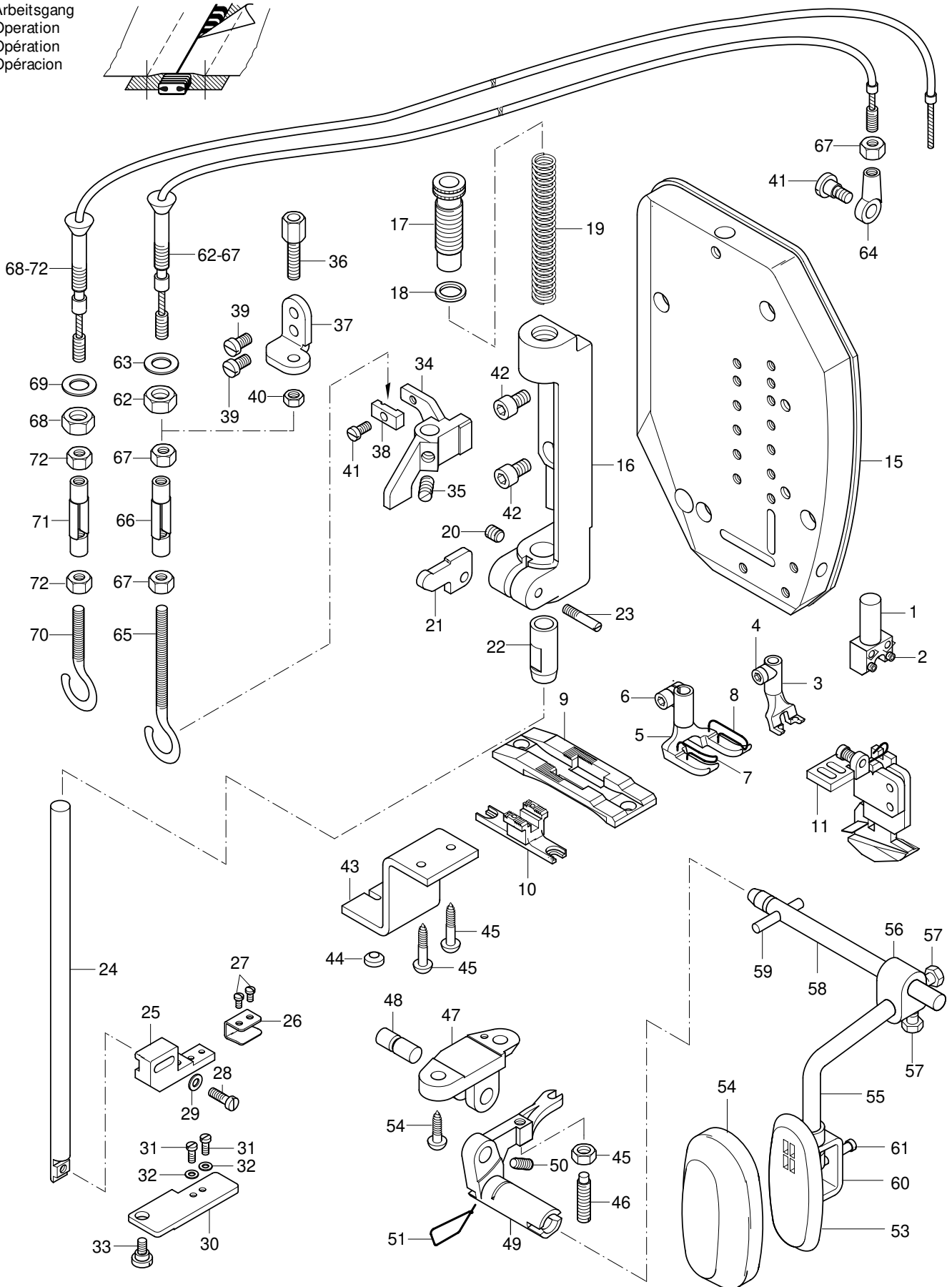
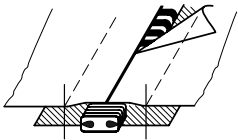



| Pos.-Nr.<br>Item No.<br>N° pos.<br>N° de pos. | Nadelabstand<br>Needle gauge<br>Ecartement de aiguilles<br>Dist. entre aguja | Teile-Nr.<br>Part No.<br>N° de piezas<br>N° de pieza | Pos.-Nr.<br>Item No.<br>N° pos.<br>N° de pos. | Nadelabstand<br>Needle gauge<br>Ecartement de aiguilles<br>Dist. entre aguja | Teile-Nr.<br>Part No.<br>N° de piezas<br>N° de pieza |
|---|--|--|---|--|--|
| 1 - 2   | 12,0   | 91-172 840-93/006                                    | 41 - 67                                       |  | 91-027 380-70  |
| 2   |  | 11-330 085-15  | 41  |  | 11-187 019-15  |
| 3 - 4   | 12,0   | 91-049 387-93/011                                    | 42  |  | 11-460 250-15  |
| 4   |  | 11-132 217-15  | 43  |  | 91-027 383-15  |
| 5 - 8   | 12,0   | 91-049 775-93/004                                    | 44  |  | 91-027 384-15  |
| 6   |  | 11-130 173-15  | 45 - 51                                       |  | 91-168 370-71/951                                    |
| 7   |  | 91-055 327-05 [3/1]                                  | 45  |  | 12-005 195-15  |
| 8   |  | 91-055 328-05 [3/1]                                  | 46  |  | 11-305 305-15  |
| 9   |  | 91-150 188-04/005                                    | 47  |  | 91-168 371-75/951                                    |
| 10  |  | 91-059 734-04/004                                    | 48  |  | 91-168 372-05  |
| 11  |  | 91-156 283-93  | 49  |  | 91-168 373-15  |
| 12 - 40                                       |  | 91-176 450-71/893                                    | 50  |  | 11-335 902-15  |
| 13  |  | 11-130 284-15  | 51  |  | 91-168 331-05  |
| 14  |  | 11-108 174-15  | 52  |  | 11-460 295-15  |
| 15  |  | 91-166 200-75/893                                    | 53 - 61                                       |  | 91-027 380-71/893                                    |
| 16  |  | 91-009 525-75/895                                    | 53  |  | 91-027 370-05  |
| 17  |  | 91-000 392-15  | 54  |  | 91-029 692-75/792                                    |
| 18  |  | 91-006 526-15  | 55  |  | 91-027 289-15  |
| 19  |  | 91-007 054-05  | 56 - 57                                       |  | 91-069 335-72/893                                    |
| 20  |  | 91-000 152-15  | 57  |  | 11-039 360-15  |
| 21  |  | 91-108 586-15  | 58  |  | 91-027 382-15  |
| 22  |  | 91-009 527-05  | 59  |  | 13-052 256-15  |
| 23  |  | 91-000 469-15  | 60 - 61                                       |  | 91-027 371-12  |
| 24  |  | 91-014 429-01  | 61  |  | 11-174 233-15  |
| 25  |  | 91-108 587-15  | 62 - 67                                       |  | 91-108 595-71/895                                    |
| 26  |  | 91-108 588-15  | 62  |  | 12-024 211-15  |
| 27  |  | 91-000 091-15  | 63  |  | 91-028 953-15  |
| 28  |  | 11-108 180-15  | 64  |  | 91-140 617-75/895                                    |
| 29  |  | 12-305 114-15  | 65  |  | 91-108 596-15  |
| 30  |  | 91-176 451-15  | 66  |  | 91-010 643-05  |
| 31  |  | 11-108 096-15  | 67  |  | 91-001 513-15  |
| 32  |  | 12-305 084-15  | 68 - 72                                       |  | 91-174 259-91  |
| 33  |  | 91-000 565-15  | 68  |  | 12-024 211-15  |
| 34  |  | 91-174 243-15  | 69  |  | 91-028 953-15  |
| 35  |  | 91-000 510-15  | 70  |  | 91-010 644-15  |
| 36  |  | 99-133 259-25  | 71  |  | 91-010 643-05  |
| 37  |  | 91-174 244-15  | 72  |  | 91-001 513-15  |
| 38  |  | 91-174 245-15  |   |  |  |
| 39  |  | 11-108 222-15  |   |  |  |
| 40  |  | 12-005 175-25  |   |  |  |

**PFAFF**